



This is a digital copy of a book that was preserved for generations on library shelves before it was carefully scanned by Google as part of a project to make the world's books discoverable online.

It has survived long enough for the copyright to expire and the book to enter the public domain. A public domain book is one that was never subject to copyright or whose legal copyright term has expired. Whether a book is in the public domain may vary country to country. Public domain books are our gateways to the past, representing a wealth of history, culture and knowledge that's often difficult to discover.

Marks, notations and other marginalia present in the original volume will appear in this file - a reminder of this book's long journey from the publisher to a library and finally to you.

### **Usage guidelines**

Google is proud to partner with libraries to digitize public domain materials and make them widely accessible. Public domain books belong to the public and we are merely their custodians. Nevertheless, this work is expensive, so in order to keep providing this resource, we have taken steps to prevent abuse by commercial parties, including placing technical restrictions on automated querying.

We also ask that you:

- + *Make non-commercial use of the files* We designed Google Book Search for use by individuals, and we request that you use these files for personal, non-commercial purposes.
- + *Refrain from automated querying* Do not send automated queries of any sort to Google's system: If you are conducting research on machine translation, optical character recognition or other areas where access to a large amount of text is helpful, please contact us. We encourage the use of public domain materials for these purposes and may be able to help.
- + *Maintain attribution* The Google "watermark" you see on each file is essential for informing people about this project and helping them find additional materials through Google Book Search. Please do not remove it.
- + *Keep it legal* Whatever your use, remember that you are responsible for ensuring that what you are doing is legal. Do not assume that just because we believe a book is in the public domain for users in the United States, that the work is also in the public domain for users in other countries. Whether a book is still in copyright varies from country to country, and we can't offer guidance on whether any specific use of any specific book is allowed. Please do not assume that a book's appearance in Google Book Search means it can be used in any manner anywhere in the world. Copyright infringement liability can be quite severe.

### **About Google Book Search**

Google's mission is to organize the world's information and to make it universally accessible and useful. Google Book Search helps readers discover the world's books while helping authors and publishers reach new audiences. You can search through the full text of this book on the web at <http://books.google.com/>



C 447,242









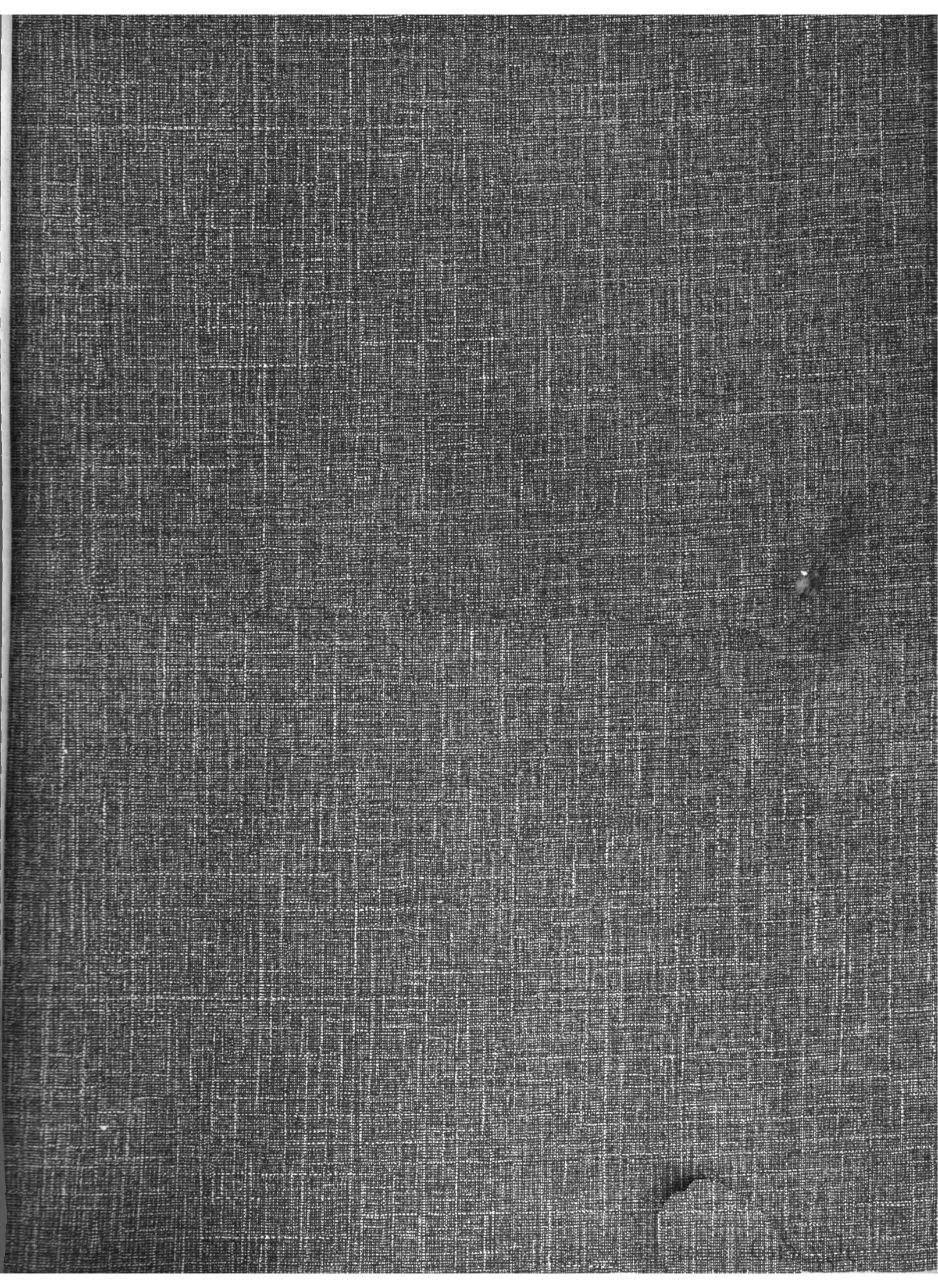



PRIVATE LIBRARY  
OF  
H. E. COFFIN  
NO.







Engin  
TL  
1  
.A96

ENGIN  
TL  
A96

PRIVATE LIBRARY  
OF  
H. E. SOFMAN  
NO.

TRANSPORTATION LIBRARY

# THE AUTOMOBILE

WEEKLY NEW YORK—THURSDAY, JANUARY 2, 1908—CHICAGO 10 CENTS

## WINTON



E, R, THOMAS DETROIT CO,  
RECEIVED  
JAN 6 1908  
ANSWERED

**1908** will be a six-cylinder year. The Winton Six-Teen-Six is *the* six-cylinder car. Does everything that you looked for in fours—and didn't find. Combines the sweetness of electricity with the flexibility of steam, and goes the route like

**Coasting  
Down  
Hill**

The Winton Motor Carriage Company

Member A. L. A. M.  
CLEVELAND, OHIO, U.S.A.

BRANCH HOUSES IN  
New York Chicago Philadelphia  
Boston Pittsburg San Francisco  
Seattle Baltimore Detroit

**Q** \$2,500 IN GOLD for 10 good chauffeurs. A plan to benefit owners and drivers. **Q** Ask us about it.



# MAJA



**THE SISTER**  
**OF**  
**MERCEDES**

**THE SISTER**  
**OF**  
**MERCEDES**

Pronounced "My-yah"

Is the latest improved product of the Daimler Motoren Gesellschaft, makers of the Mercedes Cars, named by Herr Jellinek for his daughter, Miss Maja Jellinek, just as he named his earlier model for Miss Mercedes Jellinek. The Maja Motor is the simplest, most powerful for size, and the quietest in the world, exhibiting features that will as surely advance the art of motor car making as did the previous revolutionary productions of these famous Works. For 1908 these advantages are to be had only by using a Maja Car. The Maja Car is placed within reach of all lovers of good automobiles by marketing through direct branches of the parent Company, avoiding all middlemen and agents, charging one normal profit over the expenses of manufacturing, whereby the most costly models the Daimler Works have ever made become the lowest in price to the purchaser. Full particulars from the

**American Branch of the Maja Company, Ltd., 230 W. 58th St., New York (Tel. 1393 Columbus)**

OTHER OFFICES AND BRANCHES:

LONDON

PARIS

STUTTGART

HAMBURG

ST. PETERSBURG

You are invited to attend "Maja's" debut at the Importers' Automobile Salon, open until January 4th, at Madison Square Garden. As is befitting, "Maja" has been assigned the leading position in the Show, immediately at the left of the main entrance, Space A-1.

*The* **World's Record**  
**Sealed Bonnet**

**Mora**  
MECHANICALLY RIGHT.

**Racytype**  
**Four**

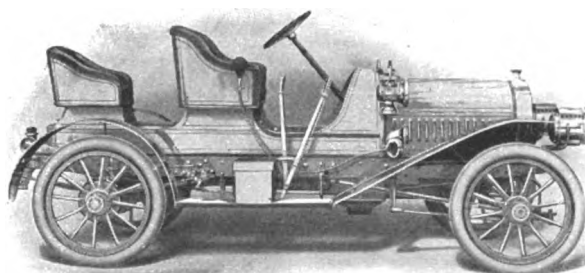

**Racytype**  
**Four**

**Finest Light Four Built in America**

The Gentleman's Ideal Easy Riding Roadster.

With double ignition \$2350.

With single ignition, \$2050.

Furnished also with sloping back box body instead of rumble seat

**MORA MOTOR CAR CO.**  
18 MORA PLACE  
NEWARK, N. Y., U. S. A.

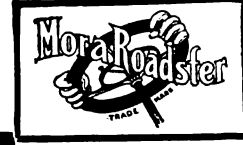

# THE AUTOMOBILE

## Importers Display Foreign Cars in Artistic Style

CREDIT for the most artistic setting of any automobile show held in New York this or probably any other year must unreservedly be given to the exhibition opened in Madison Square Garden on Saturday, December 28, by the Importers' association. Though officially designated the "Fourth Annual Importers' Salon," it is somewhat difficult to understand how the event can claim to be in more than its second year, the only other independent exhibition having been held with small success on the upper floor of a department store. Both New York shows, in which the Importers had taken some part in past years, were this season held so early that it was impossible for the foreigners to secure their new models in time for exhibition. By agreement with the Association of Licensed Automobile Manufacturers, which has an option on Madison



the general scheme of the outlay, cars being displayed at their stands down these three alleys, and the first gallery given over to accessory exhibitors. The upper gallery supplies a promenade from which an excellent view is available of the scene below. The arena space is a decorative wall reaching to an elevated platform at the back of which rises a series of arches as high as the upper gallery, surmounted by open panels decorated with coats-of-arms at the edge of the roof. Except a deep blue sign showing the name of the firm, the column supporting it having a luminous base, there are no stand decorations, yet the lighting is of such a satisfactory nature as to throw out in best relief the models on show. The concert hall forms a tea garden with natural flowers as decorations.

Square Garden, the Importers were offered the big building from December 28 to January 4, and so another attempt was decided upon to attract the attention of the public on independent merit.

Frankly, the Importers have succeeded in what was avowedly a difficult position, the spectacle revealed to the public when the doors of the Garden were thrown open at 8 o'clock on Saturday night last being an agreeable surprise. In place of the Garden of the busy A. L. A. M. show an entirely new scene had appeared, the big amphitheater being transformed and decorated as probably it never had been before. The extra space available through the comparatively small number of exhibits gave the decorators an opportunity they have not failed to take advantage of, the big hall being treated in a manner that would hardly be possible with a more compact tenancy. Under the canopied ceiling an artistic decorative scheme in French renaissance style has been carried out with an attention to detail that leaves little a: which the critical can point a finger. A central alley flanked by two side avenues, all terminating in a luminous fountain supposed to represent a scene at the Park Monceau, Paris, forms

room for diversity of opinion than regarding the general decorative effect of the show. Decorations will attract crowds, but decorations alone will not sell cars, and it is by this latter standard that every exhibition must finally be judged. Opening with a very thin house, the attendance during Saturday evening gradually increased until at 9 o'clock, though the hall was not crowded, there was an entirely satisfactory attendance, the foreign chauffeur element no longer being in a majority.

### A Select Number of De Luxe Builders.

Eighteen firms were represented in the Garden at the opening hour: France supplying ten, Germany three, Italy three, England and Switzerland, one each. Darracq and Itala, both announced as exhibitors, were not to be found, but Züst and Benz, whose names had not appeared on the original lists, were represented by a car each. Though all the models were announced to have been imported direct from the Paris show, there are three or four cases that look suspiciously like 1907 models painted to resemble the models of the coming season.

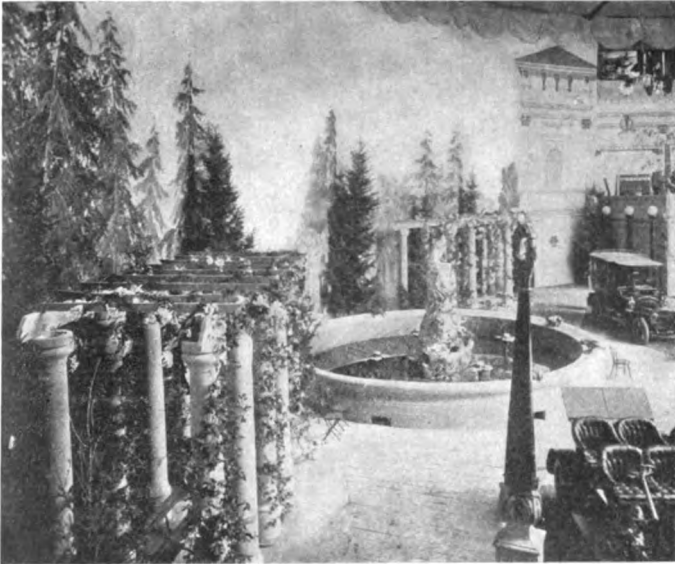

Those who had received new cars have in several cases been unable to get all their most interesting models over in time, as for instance, on the Delaunay-Belleville stand, where the smaller six-cylinder car, with its cylinders in two groups of three—one of the novelties of the Paris exhibition—is not to be seen. Dietrich's chief novelty at the Paris exhibition, a shaft-driven town vehicle, is also a missing quality. Renault, on the other hand, possesses a most complete line, which if not including every type of vehicle built at the Billancourt factory, at any rate comprises all those of interest to an American public, and that is saying a great deal.

It was not to be expected of an importers' exhibition, working under a 45 per cent. import duty, that popular vehicles would be in evidence to any extent. Practically all the cars shown are powerful models with a respectable number of figures attached to their names on the price lists; a limited exception is to be found in the town vehicles of half a dozen firms, with a power rating at something below twenty. In the examples of body-work, too, shown by three American makers, the same high-grade article is exhibited of a nature to interest only those able to pay for the best.

#### Show Does Not Indicate Trend of Design.

Being a trade exhibition pure and simple, the Importers' Salon is valueless as an indication of the trend of design or methods of construction of any country; even the ten French firms, important as they are, cannot claim to adequately represent their

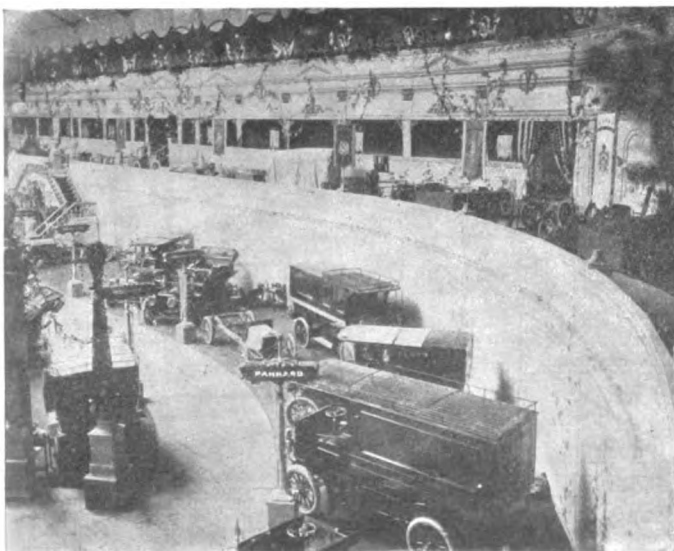

country's national industry, and the same is true to a greater extent of the models shown from Italy, Germany, Switzerland and England.

Special chassis for town work form the outstanding feature of the exhibition, widely differing but interesting models being shown by Panhard, C. G. V., Fiat, Hotchkiss, Renault, Maja and Delahaye. A low, side entrance body, easy steering, turning and control, and a silent engine are in general the features which European constructors have set themselves to develop for the special types of gasoline cars which in their own countries have almost driven out the electric as a town conveyance.

With the exception of the little Delahaye, fitted with a two-cylinder engine, all the town vehicles have four-cylinder engines, and all without exception have final drive through propeller shaft and rear live axle.

There is an interesting example of casting *en bloc*, so popular with makers of town vehicles desiring compact power plants, in the new 16-horsepower Hotchkiss, which Manager J. J. Mann, foreign technical adviser to the A. A. Racing Board, had brought over with him from Paris and was never tired of explaining to visitors. With valves on one side, all piping, both inlet and exhaust, has been cast as an integral part of the engine, the exhaust being arranged in such a way that on looking at the engine it is at first difficult to see what becomes of the spent charges from the engine. This is explained by the fact that the inclosed exhaust pipe opened at the rear of the last cylinder, the piping passing through the dashboard and connecting immediately to the engine. The arrangement of the inlet piping, or rather its absence, is a distinctive feature, the only connection being a short length of pipe from the carbureter to the engine. As the carbureter is on the opposite side to the valves, the charge is led across and distributed to the valves by internal piping. The consequence of such an arrangement is an extreme simplification of the engine, the water inlet and outlet and metal casing containing the wires being the only piping. It is interesting to note that unless specially ordered the Hotchkiss people no longer fit ball bearings in the engine, the abandonment being rendered necessary owing to careless handling on the part of inexperienced or careless drivers and owners.

The only other example of four cylinders in one casting is in the C. G. V. town vehicle, where valves are also all on one side, but in which more standard design is followed. A feature, however, is an asbestos-lined metal casing around the exhaust manifold.

#### Self-starter on Renault Town Car.

Renault presents no particular model which by reason of outstanding features can be termed a town vehicle, there being a close similarity in points of construction between the smallest and the largest of the cars built by this firm, but the 10-14-horsepower four-cylinder model possesses such qualities of silence, flexibility and compactness as to have earned for it the title of Queen in its class. No distinctive changes are noticeable on the engine of this model, the cylinders as before being cast in pairs, with valves on one side, magneto in front, and tubular radiator on the dashboard.

Among the new features of the chassis will be immediately noticed an additional pedal to the left of the clutch pedal, by simply depressing which the motor can be started up from the seat. An attempt to solve the problem of self-starting was presented by Louis Renault at the Paris Salon two years ago, the device of that date having but little in common with the arrangement now in use on the smaller Renault cars. All the mechanical parts connected with the self-starter are contained in a compact metal case mounted on the gear box, in such a way as not to interfere with the opening of this organ. The arrangement appears to be eminently simple, necessitates no change whatever on the engine, and should have a longer reign of usefulness than some of the self-starters which, conspicuous on 1907 models, are absent on the corresponding models for 1908.



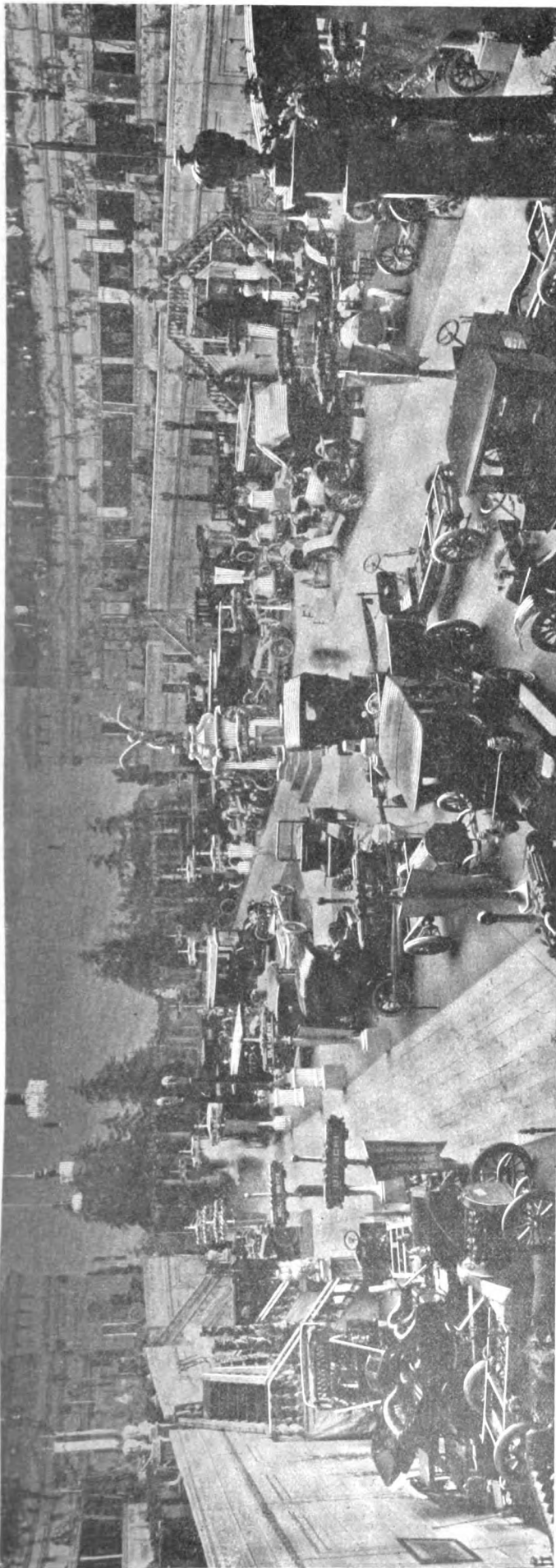

Copyright, 1908, The Pictorial News Company.

Three-quarter elliptic springs are to be a feature of all Renault four-cylinder models for 1908, and wherever desired patent shock absorbers designed by Louis Renault will be fitted front and rear. Since the adoption of three-quarter elliptic springs the rear construction of the chassis has been slightly changed, the broad angle stays being abandoned for smaller semicircular binders, having a much neater appearance. The new type of suspension is declared to be more steady, to cause less rolling with heavy bodies and to twist the chassis less than the platform type, which was formerly a standard feature.

#### Panhard's Shaft-driven Car.

Panhard's first shaft-driven car—other than racers—is too solidly constructed for its usefulness to be confined solely to service over well paved town streets. Yet it has been designed especially to meet the demand for a silent car suitable for work in cities. The car is an entirely new production, departing considerably from Panhard practice in both engine and transmission. The four cylinders are cast separately and are approximately 3 1-2 by 5 1-8, rated at 15-20-horsepower at 1,300 revolutions.

Most prominent in the engine design is the sliding exhaust valve camshaft operated by a foot pedal; by means of which the engine can be used as a brake. The same arrangement is to be found on the larger models, thus giving for Panhard cars three independent sets of brakes. Both camshafts are contained in the upper part of the crankcase and are removable from the rear by disconnecting a detachable disk. Gear set and multiple-disk clutch are contained in one housing set rather more to the rear than usual. The engine flywheel is fitted with fan blades, and the main shaft from the engine to the clutch is equipped with an intermediate bearing. Owing to the position of the gear box, an exceptionally short propeller shaft is necessary to carry the drive to the rear axle; a steel sleeve bolted to the differential casing at the rear and attached to a cross member forward by forked arms and spring suspension, surrounds the propeller shaft and acts as a torque rod.

An unusual form of pressed steel frame is shown in the Fiat shaft-driven town vehicle, the side members being deeply dropped to give the lowest possible entry, the face of the frame considerable broadened as it leaves the sweep, and narrowed in front to give a wide steering angle. The rear axle casing, too, is distinctive in consisting of a two-piece stamping bolted longitudinally. Delahaye displayed the only two-cylinder cars in the exhibition, two models being on view, one a cab complete with taximeter as used by the New York Transportation Company, and the other a similar chassis with a more elaborate closed body.

#### Sixes Are Only Moderately Numerous.

Among the larger models shown at the Garden the greatest novelty is undoubtedly the six-cylinder Renault with automatic self-starter. When the show opened the six was the only vehicle not in place. An hour later its appearance was announced, and in almost less time than it takes to tell Bernin had climbed up behind the steering wheel, steered the car to a position on the stand, and workmen were busily removing the effects of sea water on the unprotected parts.

On this model as well as the larger four-cylinder cars a compressed air self-starter is fitted as an extra wherever required. The device consists of an air-cooled pump on the forward end of the engine, driven off the distribution gears, and compressing air into a metal tank hung within the frame. All the control of the apparatus is fitted to the right hand side of the dashboard, the operation of a small lever here allowing the air to pass from the tank to the cylinders through a rotary distributing valve. Use can be made of the compressed air for tire inflation purposes, by a Michelin outlet and pressure indicator attached on the dashboard. Two bolts only, held in their base by swivel joints, held the pump in position, dismantling being thus the

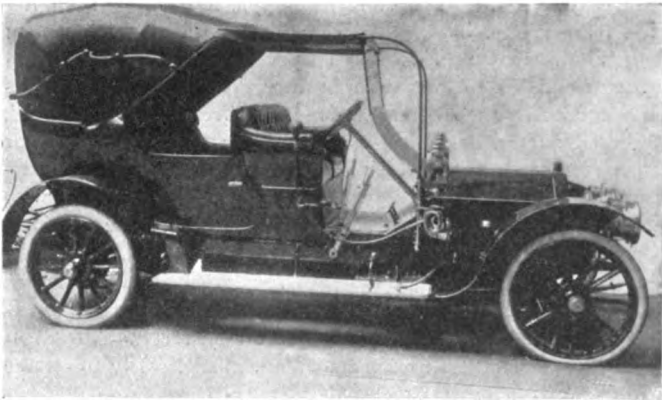

**PROTECTION AGAINST THE WEATHER, A LA ROTHSCHILD.**

simplest operation. Altogether the design and workmanship of the self-starter is a production calling for unstinted praise.

In all essential features the Renault six is merely a case of adding another unit to the four-cylinder engine, transmission, drive, suspension and other features being similar with the exception of strengthening for the extra load that the car is intended to carry. In addition to the several chassis shown on the Renault stand, a number of cars were displayed with handsome closed bodies, and the racy runabout which established a new track record at the Morris Park twenty-four-hour race has a place of honor.

Hotchkiss, Fiat, Delaunay-Belleville, and Rolls-Royce supply the remainder of the sixes at the Garden, Delaunay-Belleville having the cylinders cast separately, Rolls-Royce with two groups of three each, and the other with castings in pairs.

#### Rendering the Engine More Accessible.

Refinements in detail which render an engine more accessible or simplify the care of a car are probably no more carefully thought out on any vehicle than the Delaunay-Belleville. Securing the magneto on its platform by means of an encircling band is too common a practice now to call for much comment; in the Delaunay-Belleville models not only is the magneto secured in this manner, but the pump, carried on the opposite side of the engine, has a similar method of attachment. After disconnecting the two lengths of piping, all that is necessary to dismount the pump is to unscrew the band attachment and lift it off its pins. All the electric cables are contained in metal tubes, which instead of being attached permanently by screws are held to the water piping by spring clips; thus the magneto and all cabling can be dismounted in a few seconds without the use of tools.

Benz, Züst and Maja constituted a trio which might be regarded as newcomers, though all have an excellent reputation

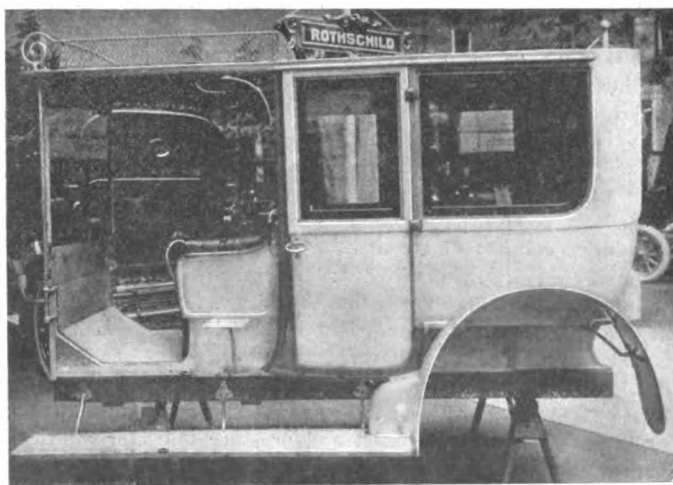

**AN EXCELLENT EXAMPLE OF THE USE OF ALUMINUM FOR BODIES.**

on the other side of the Atlantic. Maja is newer in name than in deed, for the newcomer is a member of the Mercedes family, marketed direct in America by a separate company, but built very largely on the well-known Mercedes lines. One distinctive feature is that either shaft or chain drive will be supplied to order on the two models now on the market.

#### Carriage Work Reveals Good Native Talent.

In body work American firms occupy a larger share of space than the foreigners, most of the chassis from abroad being equipped with bodies made in this country, principally by such well-known makers as Rothschild, Quinby, and Brewster. The credit of the biggest body belongs to the Delahaye stand, where

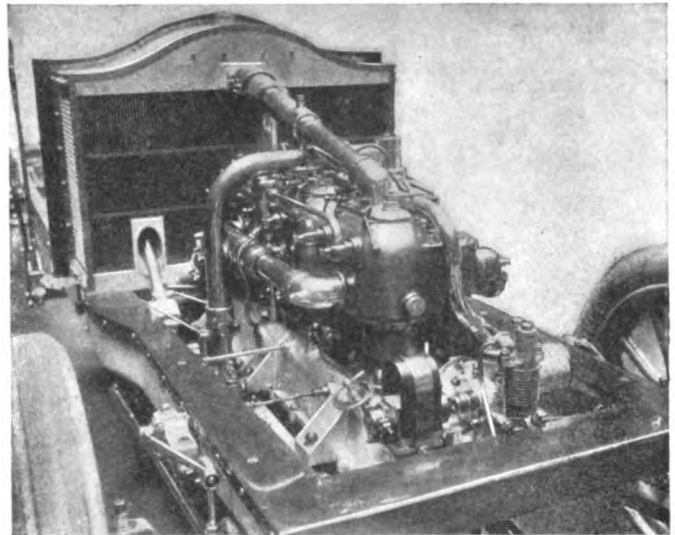

**RENAULT SIX-CYLINDER CHASSIS WITH AUTOMATIC SELF-STARTER.**

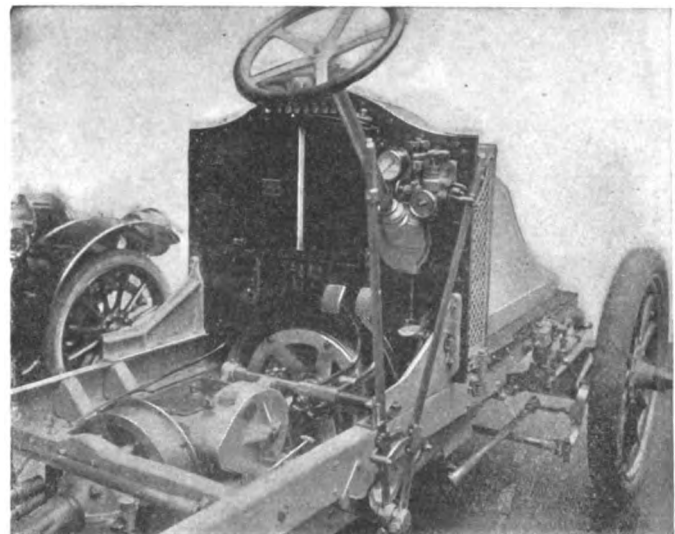

**HOW THE SELF-STARTER AND TIRE INFLATOR ARE CONTROLLED.**

a rear entrance saloon car is shown, fitted with four armchairs and a couple of writing cabinets. The car is excellently upholstered, fitted with electric light, electric annunciator and every luxury usually only associated with the most comfortable rail-road travel.

Apart from this, all the bodywork is more marked for excellence in workmanship than eccentricity in design, houses on wheels not generally being a great success even on the best roads of Europe. Two or three cases were noticed where the rear seat of a touring car was divided into either two or three, in the same way as is commonly done for the front seats. A Flandrau body on a Pilain chassis is a good example of this, other improvements on the same car being footboards which can be



raised to any desired angle, and folding seats attached to the side of the tonneau by a single slot and pin without the use of a leg for the seat. There is a tendency on the landaulet bodies to provide protection for drivers, at present left fully exposed to the weather. This is accomplished by a neat folding hood to lie near to the closed body when not in use, extending outward as far as the dashboard when opened.

A distinct novelty in the covering of an open touring car is shown on an Isotta-Fraschini with a short top with only one side bow, extending forward as far as the back of the front seats. The driver is protected by a Huillier windshield, swinging at the top, and connected to the dashboard by a leather apron. Between the hood and the shield a waterproof leather cover can be buttoned in position, completely protecting both passengers and drivers. With such an arrangement the protection afforded would not be equal to that of a car with a large cape top, but would still be sufficient to keep off heavy rain and have the advantage of adding little to the weight of the car and of being easily stowed away.

As an example of what can be done with aluminum in the construction of high-grade carriage bodies, Rothschild displays a limousine in an unfinished condition built exclusively of this metal, the use of which has allowed a minimum of joints impossible with any other form of construction. There were numerous other examples of aluminum body construction, though none that equaled this for the employment of large sheets of metal without seams, or that revealed so perfectly what can be done with this metal. Carriage work was invariably of the highest grade, a feature of the finish being the employment of subdued tones and the dull finish of much of the metal work hitherto conspicuous for its glitter.

#### Accessory Display Is Largely a Repetition.

On the mezzanine floor, accessory dealers hold their usual display of the thousand and one articles useful if not always absolutely necessary to the running of an automobile. In the majority of cases these have been exhibited at the preceding shows in the Garden or the Grand Central Palace and provide little in the way of novelty.

Merely as a means of drawing attention to a well-known article, the use of a couple of small wagons at the Truffault-Hartford shock absorber stand is novel and effective. One of the little vehicles is fitted with shock absorbers, the other is not. Each one is placed over a revolving drum with a raised leather band across its face, and nothing could better exhibit the value of the shock absorbing device than the relative behavior of the two cars when the drum revolves.

A new force-feed oiler, patents for which have been obtained in all foreign countries, was shown by the Geo. Wood Manufacturing Company. The features of the instrument are the positive flow of oil and the extreme simplicity of all the parts, as an example of which may be mentioned the entire removal of all the plungers on the withdrawal of three screws. Driving the oiler in a reverse direction, no matter at what speed, could not possibly injure it.

In the tire realm one of the few novelties is a dismountable rim introduced by the Healy Leather Tire Company. Unlike the majority of quick-change devices on the market, a double rim has not to be employed, the dismountable rim attaching direct to the spokes of the wheel by means of patent clips with a screw for each. The advantages are a saving in weight, a dismountable rim of the Healy type being no heavier than an ordinary wheel, the impossibility of binding, for two metal surfaces are not brought together, and the retention of the ordinary valve and safety lugs. It should be possible for any ordinarily experienced person to make a change of rim by the Healy method in three minutes, the operation being the simple one of slackening a nut at the end of each spoke, changing the rim and tightening up again. The only tool required is a screw brace.

Arctic exploration being the order of the day, the Healy peo-

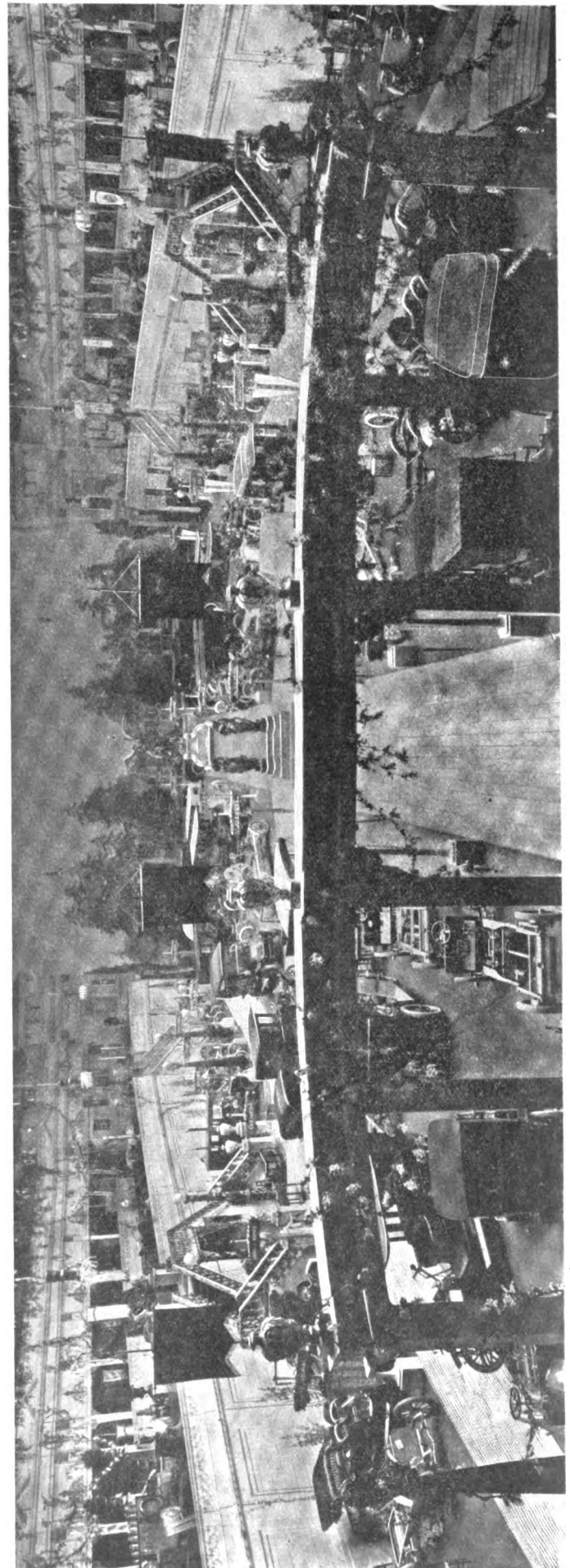

Copyright, 1908, The Pictorial News Company.

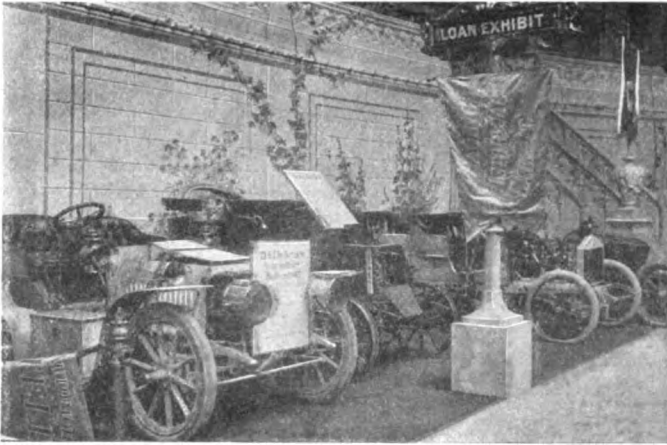

A FEW RELICS FROM THE EARLY DAYS OF THE CENTURY.

ple have adopted a steel-spiked rim to their new device, the Arctic aid being a steel rim to take the place of the tire rim, its face instead of being grooved for the tire, being studded with projecting steel spikes, certain to find a hold on any frozen surface.

#### The Locomotion of the Ages.

Madison Square, like Paris, has its retrospective exhibition, the home event comprising four units: an ancient Dietrich; an equally venerable Panhard, with a true tonneau such as no modern dealer could supply on request; a Renault racer, which figured in the Paris-Madrid of 1903; and a four-cylinder Rolls-Royce, which bore a very close resemblance to the car with which Rolls won the Tourist Trophy race in the Isle of Man.

Taking another lesson from the note-book of the Paris exhibition, the Importers organized a spectacular fête on New Year's eve, the subject of which was locomotion throughout the ages. Going back to pre-Adamite days, the parade, led by a band, showed the first stage of locomotion in the form of a monkey on all fours. Man walking on his hind legs came as the natural successor, an oxen following next in the stage of development. After this slow and ponderous beast, came each in its order, the representatives of the transportation of the ancient civilization of the East—Hindoos bearing a palanquin on their shoulders, the sprightly Jap dragging the forerunner of the buggy behind him in the shape of the jinrikisha, and then the first of the swift four-footers, the Egyptians, Romans, and Greeks in their chariots, and again a retrogression, so far as speed was concerned, in the shape of the elephants of the Persians, and the European sedan chairs, followed as a wind-up of this part of the procession, by donkeys and horses drawing the first fourwheelers.

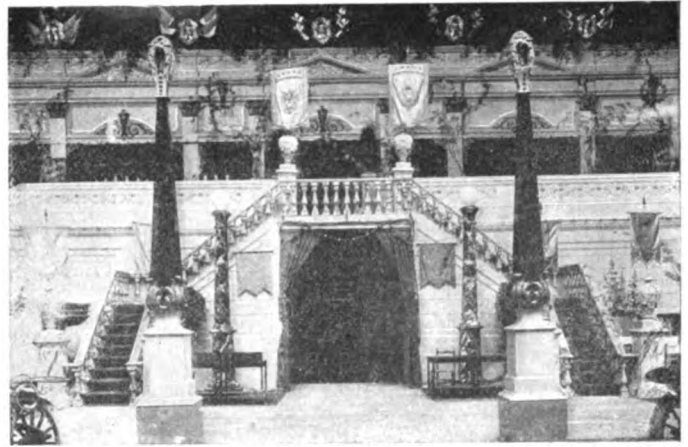

HOW CONNECTION WAS MADE FROM GROUND FLOOR TO GALLERY.]

Then came the age of steam, represented by an engine, and the next step in the form of a bicycle, while following closely upon its rear wheel came the final triumph of modern genius in the field of locomotion—the automobile, with old Father Time driving a replica of the first automobile, while its modern successors were guided by the "Spirit of 1908."

The pageant solemnly filed round the aisles of the Garden during the witching hour when all the outside world was welcoming the New Year in an ecstasy of noise, but the novelty of the procession and the interest it excited made it a drawing card on New Year's day, when it was repeated at 4 o'clock in the afternoon and again at 9 o'clock in the evening.

The brunt of the labor in connection with the highly successful Importers' show naturally fell on the show committee, consisting of André Massenat, E. Lillie, E. R. Hollander and General Manager C. R. Mabley, though others connected with the display comprised J. S. Josephs, president; C. F. Wyckoff, S. B. Bowman, Paul Lacroix, Gaston R. Rheims, Percy Owen and Geo. M. MacWilliams. Credit for the excellent decorative effect, which has aroused universal admiration, is due to S. R. Ball. Naturally numerous conjectures have been made as to the cost of what is undoubtedly the finest decorative scheme seen at any American automobile show, \$60,000 being quoted in very authoritative circles. As it is intended, however, to dispose of almost the entire effects to the promoters of a succeeding show, the final cost will doubtless be considerably lower than the figures quoted. Though this first real show independently fostered by the Importers cannot be put down as being other than a great success in many ways, there is a more or less settled conviction that it is the first and last of its kind to be seen in New York.

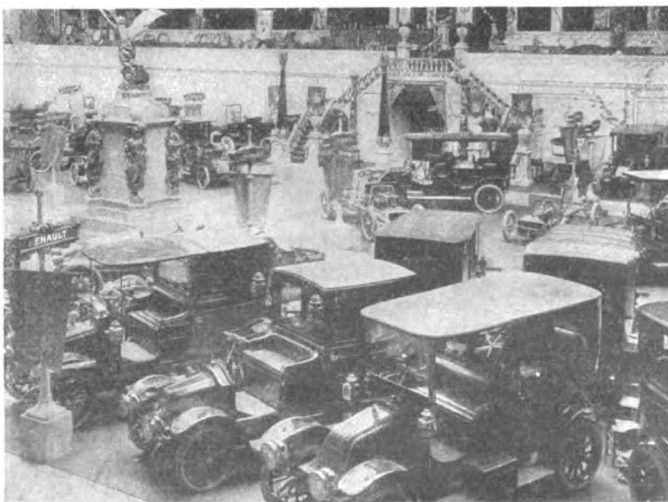

RENAULT POSSESSED ONE OF MOST COMPLETE EXHIBITS IN SHOW.

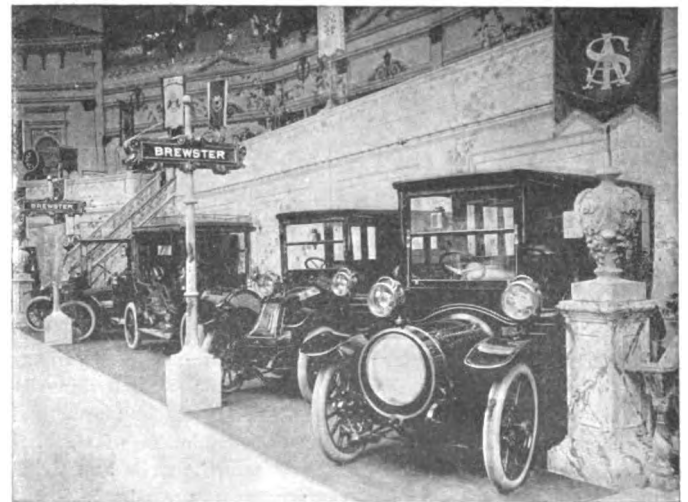

BREWSTER BODIES ON SOME OF THE FINEST FRENCH CHASSIS.

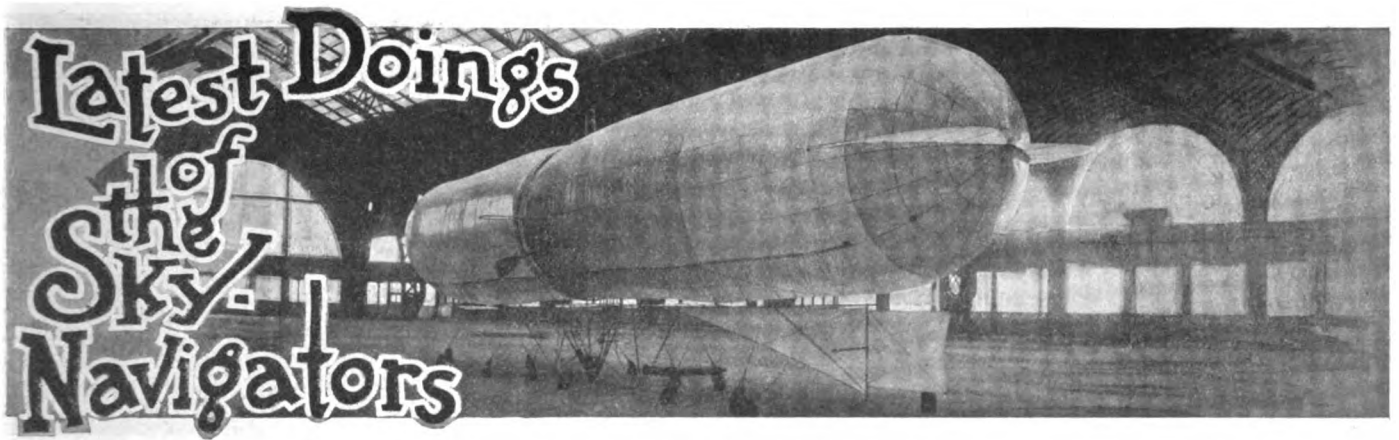

MARCAI DIVIDED AIRSHIP. WITH PROPELLER AMIDSHIPS BETWEEN TWO HALVES, SHOWN AT GALERIE DES MACHINES, PARIS.

PARIS, Dec. 23.—A dirigible balloon with its propeller in the center is an aeronautical novelty attracting the sky navigator to the Galerie des Machines, Paris. Baron Edmond de Marcai and a Dutch engineer, M. Kluytmans, have produced the new ship with a view to overcoming the lack of stability which is generally found in vessels of the *Patrie* and *Ville de Paris* types as soon as the propellers are put into operation. In the former class the double propellers revolving at 1,100 revolutions a minute are carried below the envelope in the center of the cage; in the latter class a single screw turning at 140 revolutions a minute is carried at the forward end of the cage. Removed some twenty or thirty feet from the center of the balloon the defects of the two systems are apparent in a strong wind. To overcome the difficulty, compensators have been employed with considerable success, and naturally the lines of the ship influence in no small measure, but when all has been done rolling is the *bête noire* of the aerial sailor.

The Marcai airship consists of a couple of long sausage-shaped bags placed end to end and having a connection through the center of their axis, in order to equalize the gas pressure in the two compartments. The propeller is attached to the frame in the center of the balloon, its two arms describing a circle of larger diameter than that of the balloon. The motor is carried on an under frame below the gas bag, transmission being by means of a long belt. Experiments made in the Galerie des Machines, the balloon being guided along by a rope, were thoroughly satisfactory. As soon as possible outdoor experiments will be undertaken, for as the propellers have been arranged to improve stability it is only by trials in a wind that their real worth can be determined.

#### Aeroplanists Busy Training.

PARIS, Dec. 23.—Santos Dumont is busy on *The Butterfly* No. 19, although No. 18, a water craft, has not yet fulfilled the mission for which it was created. The latest edition of *The Butterfly* is a modification of one which appeared at Bagatelle nearly two months ago without much success. Instead of a single propeller forward, it has been reconstructed to provide two separate propellers of bamboo frame covered with silk, both at the forward part of the machine, and driven by a round belt. The motor retains its original position in the angle of the two wings, made of bamboo frame covered with varnished silk. The method of transmission, with which Santos Dumont is said not to be altogether satisfied, is

somewhat unusual, a crossed belt running from the flywheel of the engine to a bicycle wheel with a grooved face, to which is attached one of the two-bladed propellers; the companion propeller is driven by a connecting rod from the belt-driven wheel. No other changes appear to have been made in the construction of the aeroplane, the machine being one of the lightest and smallest ever seen on a testing ground. What it is capable of doing under practical conditions has not yet been determined, for on the first day that speed was attempted the belt came off and broke one of the propellers. It was not a serious accident, but several days will pass before another run can be made.

Henry Farman, unlike his principal rival, remains true to one machine, but loses no opportunity of training both himself and it for the kilometer flight in a circle. Bad weather has hindered the attempts of the last few weeks, but on every occasion on which it has been possible to be out he has made attempts at flight. During the past week he has made a number of flights varying in length from 300 to 400 yards with ease.

Louis Bleriot, in an attempt at Issy-les-Moulineaux to capture one of the club prizes for a 150-meter flight, was exactly five meters short of victory and a shorter distance of meeting his death. An excellent flight had been made in the presence of the Club Committee, which terminated so successfully that all thought the prize won. On measuring the ground, however, it was discovered that the flight was five meters short of being up to standard, and a fresh attempt was begun without delay. The second flight, made at three yards from the ground, was apparently successful, but on descending, the left road wheel collapsed, the wing scraped the ground, and in a second the aeroplane had capsized. The committee, followed by Madame Bleriot, who was on the ground, rushed to the spot and withdrew the skypilot with some difficulty, happily uninjured except for a bruised shoulder. His machine, however, was badly damaged, the propeller and shaft being broken and the wings injured. The Antoinette motor, however, was in perfect condition. Bleriot, though possessor of some of the most promising aeroplanes, designed and built by the best makers, has so often met with accidents when success seemed certain that his ill-luck has become proverbial among French aeronauts.

The Ferber-Antoinette aeroplane, designed and built by the maker of the celebrated light weight motor, has reached completion and is expected to be tried out as soon as weather conditions are satisfactory. The motive power is a 100-horsepower 16-cylinder Antoinette engine.

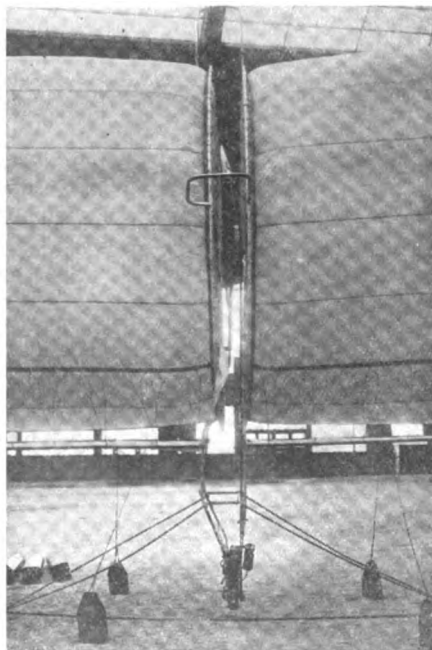

CENTRAL PROPELLER AND MOTOR.



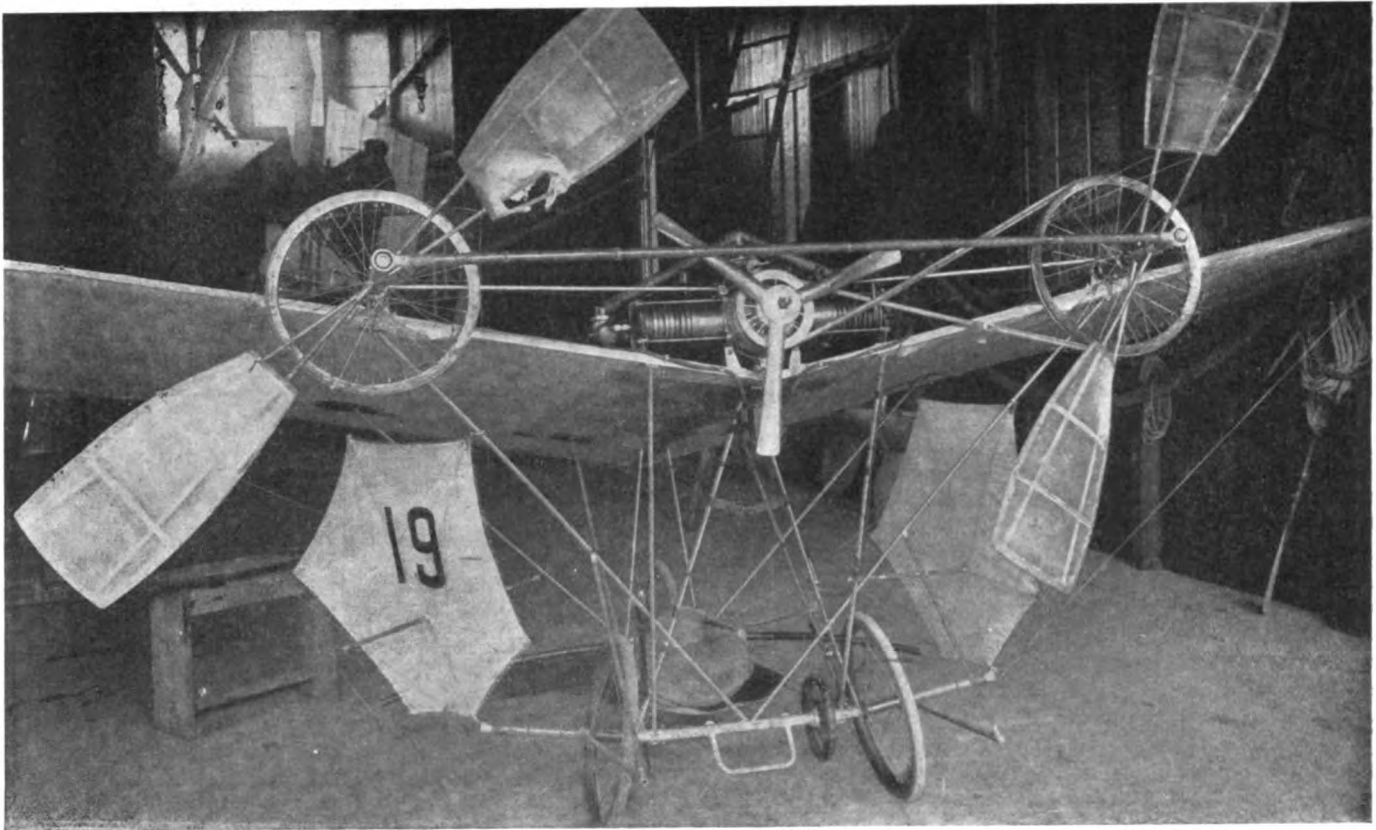

SANTOS-DUMONT'S BUTTERFLY AS IT APPEARS WHEN FITTED WITH TWO ADDITIONAL BELT-DRIVEN PROPELLERS.

#### FARMAN WILL CELEBRATE NEW YEAR FLYING.

Henry Farman is again ready for an attempted flight of a kilometer in a closed circle, the accomplishment of which will entitle him to the Deutsch-Archdeacon prize of \$10,000, according to dispatches received from Paris. On Monday afternoon at the Issy-les-Moulineaux drill ground, near Paris, Farman brought out the aeroplane which he has employed for the past few months, but which has recently undergone some minor improvements, and almost succeeded in accomplishing a record flight. After running on the ground for a couple of hundred yards, the machine shot into the air and traveled to the extreme end of the open ground, at a height of about three yards. Farman then operated the rudder and began a difficult turning movement, which, when about half accomplished, was spoiled by a group of workmen getting into his path. To avoid hitting them the aeroplane had to be suddenly swerved, causing the wheels to touch the ground for a fraction of a second. Rising again immediately, the flight was finished in magnificent style, the machine being brought to earth within a few inches from the spot on which it had started. Farman declares that he has considerably improved his aeroplane by covering the front edge of the lower plane with canvas, rounding it off and reducing the air friction. When he has made the same change on the upper plane he believes that still better results will be possible.

Official notice has been given the Aero Club officials that Henry Farman will make an attempt to win the Deutsch-Archdeacon prize this week. To claim the \$10,000 prize the machine must cover a distance of one kilometer in the air, leaving the earth on a given line, turn around a post 500 meters ahead, return and cross the starting line again, descending at the point from which it took flight, or, if that is impossible, dropping in its flight some object within a circle of 25 yards from that point. The severity of the test lies in the turn around the outer post and the descent to earth at almost the exact starting point. Having on two separate occasions come within a few inches of meeting all conditions for the prize, when on practice spins, it is believed that Farman has every chance of winning the gold.

#### BERLIN TO SEE START OF THIRD AERO RACE.

Berlin will succeed St. Louis as the starting point of the third annual international race for the Gordon Bennett Aeronautical Cup, according to information received from Germany by the Aero Club of America. By reason of the victory of a German pilot in the last contest the next race must be held in Germany at any suitable point selected by the national club. After a thorough search and a consideration of the claim of a number of cities, the capital has been decided to be the most convenient spot from which to start the aeronautical competitors, the date of the 1908 race to be about October 1. Assurance is given that the Kaiser, who has always taken a keen interest in aeronautics, will be present at the start of the race. Owing to the large number of German aeronauts desiring to participate in the race for the cup, it is probable that elimination races will be held to select a team. France and America have already sent official challenges for the 1908 race.

Lieutenant Frank P. Lahm, winner of the first international balloon race, started from Paris in 1906, returned to America last Sunday on board the St. Louis. After undergoing a special course of training at the French military cavalry school at Saumur, Lieutenant Lahm was commissioned by the United States Government to make a thorough investigation into aeronautical matters throughout Europe. For this purpose he has visited France, England and Germany, examined the military airships of these countries, and had an opportunity of witnessing all recent aeroplane experiments in France. Lieutenant Lahm will proceed at once to Washington to present his report.

#### AERO CLUB MEMBERS AROUND FESTIVE BOARD.

Members of the Aero Club of America will unite in the second monthly club dinner at 6:30 p.m. on Tuesday, January 7, in the dining room of the Automobile Club of America, on Fifty-fourth street, west of Broadway. Dinner will be followed by an interesting lecture by Courtland Field Bishop and later by a smoker.

# THE FUEL SYSTEM OF AUTOMOBILES\*

By THOS. J. FAY, E.E.

IN the case of a new motor it is not so easy, for then it may be a question of adjustment, or perchance the carbureter is not of the right type at all. True, it would be strange for anyone to employ a carbureter of a character unsuited to the motor, in any given case, but such things are done, and it is necessary to take this phase of the situation into account. On one occasion the author essayed to deliver a new car to a friend, a car, in fact, of which the author had but slight personal knowledge. A brave start was made, but it ended in a long struggle, because one of the valves of the carbureter was not present, having been overlooked in the assembling process, and no notice was taken of the fact because the author did not know how the thing was constructed. It was necessary to call upon the maker to send a man to try to make the motor work properly, when, lo and behold, the expert fell into the same trap. In the end a little waste pressed into the passageways produced the same result as a valve and it was easy to discover that a part was missing.

The great question is to think, and to systematically try the various schemes likely to solve the problem, when the carbureter fails to do its work. Some of the ills are due to one cause and more to another. If the motor will not crank to a start, the mixture may be impoverished; if so, it is necessary to proceed to render the mixture rich by throttling the cold air and by reducing the area of the hot air passageway until the amount of fuel is sufficient to render the mixture efficient.

At such a time it is a good idea to make sure that the gasoline is present in adequate volume, and that water is not in the way. The pressure should be looked after, and it is well to make sure the spark is satisfactory. But a few days ago a friend called the author on the 'phone, late at night, and stated that he was down on Long Island with a car and could not make it "budge." He had tried every device known to the experienced motorist, but to no avail, so he said. The car was a "one-lunger," and it occurred to the author that the spark plug (porcelain) was split. Mr. Motorist said no, but after some talk he was induced to try a new plug, only to find that the motor cranked readily and gave no further trouble at all. Later the author learned that the autoist had previously tried the plug (in the air) and since it gave a good spark he assumed it was not defective. He did not take into account the fact that the resistance in the air is far lower than when in the cylinder under compression. The split in the porcelain was so slight as not to be seen at night, but it was enough to defeat the spark.

### Think First and Look for Trouble After.

If the spark is good and the timing is right, it is then possible to proceed to locate carbureter trouble with a good measure of confidence. The more easy, to be sure, if the car may have previously performed in a satisfactory manner with the same carbureter; but it is always a good idea to think first and look for the trouble afterwards. On one car the gasoline pipe was led to the carbureter in a very roundabout manner and the author, en route from Rockaway Beach at night, miles from a habitation, found himself with a dead car, and after some time discovered that a "cock" in the gasoline pipe, well concealed under the car, with the handle so set as to jar the cock in the closed position, had succeeded in doing so. The cock leaked slightly and every time the carbureter was examined it showed gasoline. Upon starting the motor it would run for a moment and then die; there was no way to tell just what was the trouble, and it looked like a case of camping out all night. Upon entirely removing the pipe the trouble was found.

The relation of the hot to the cold air is a matter to adjust with some care. The hot air, as a rule, enters by a passageway

in juxtaposition to the nozzle, or the nozzle is in the hot air passageway. At all events the hot air is necessary in the process of vaporizing the gasoline and must be in quantity sufficient to do the work. Gasoline is a refrigerant, that is on changing from its liquid to its gaseous state the temperature is lowered, but in view of its low efficiency in this respect the amount of hot air needed is not great. In cranking a motor the cold air port is closed completely and the hot air port is so closed as to assure a rich mixture, so rich, in fact, as to supply an adequate fuel value, barely to keep the motor in motion at lowest speed.

That the flywheel has much to do with the matter may be proven by the simple expedient of trying to do without a flywheel, whilst on the other hand the heavier the flywheel the slower will the motor run if the mixture is rich and homogeneous. Just what should be the richness of the initial mixture is a matter to be settled in time, if in time knowledge of the fact will be afforded. As it is, one may be sure the mixture may be more rich if the compression is high than if the reverse is true, and it may be the richness, if the mixture is not far from five volumes of atmospheric air to one volume of vapor of gas-

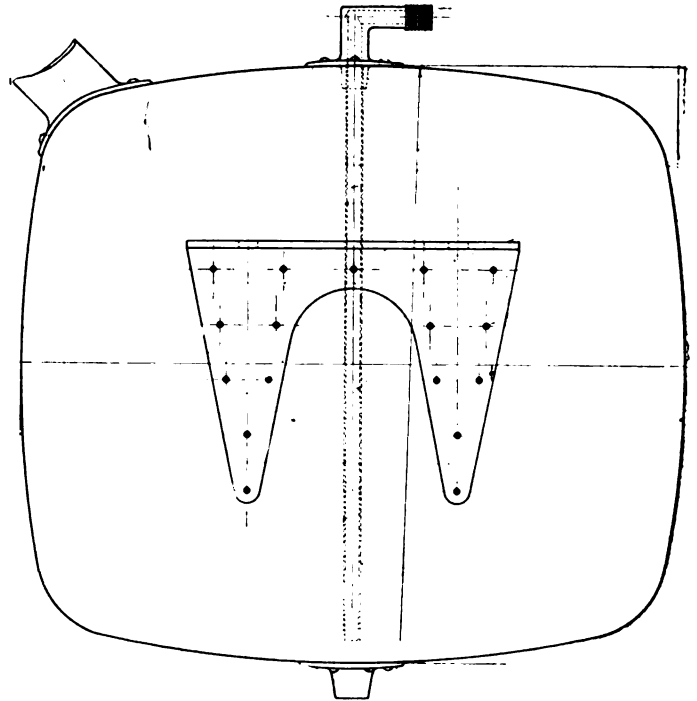

FIG. 1.—Details of copper fuel tank and supporting bracket.

oline. Such a mixture would be very slow-burning and would be favorable to the starting project. It is necessary to have a slow-burning mixture, starting or running slow, else the piston would not get out of the way of the wave and the energy would be spent in heat to the water jacket, since a high increase in pressure would mean a high rate of transfer to the jacket.

There is always a certain relation of the rate of inflammation of the mixture to that of the velocity of the piston that evolves the maximum of useful work. This view of the matter seldom if ever receives a measure of attention, and it must be taken into account. Carbureters, as they are sometimes built, allow for a constant richness of the mixture, and a variable supply; the variable supply affects the rate of inflammation and in a way acts the same as if the richness were altered to bring about the same end. If, however, the throttle is used, the number of heat units change, whereas, if the fuel valve is held constant per cubic inch of mixture the fuel will do more work. Torque (pull in pounds at unit radius) is what is wanted, either in

\* Continued from page 945 of THE AUTOMOBILE, issue of December 26, 1907.

starting or in running a motor at a slow rate of speed. Plainly, then, the change in quantity of the mixture is not so likely to produce the best results as if the thermal value be changed to produce a slower rate of inflammation with decreasing speed, or an increasing rate of inflammation with increasing speed, the

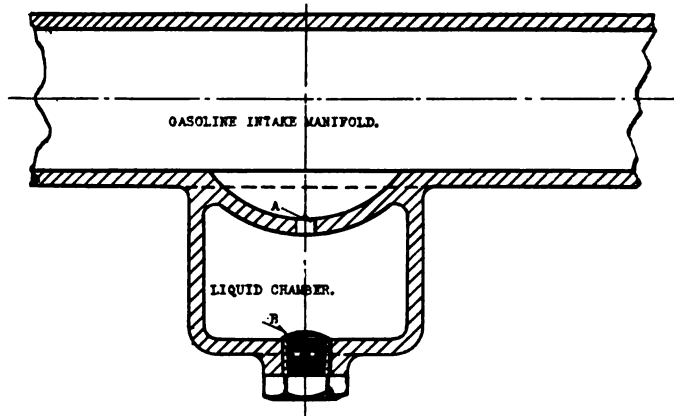

FIG. 2.—"Skimmer" or sump to collect liquid gasoline from manifold.

product of decreasing thermal value being brought about by the simple expedient of diluting the mixture with cold air.

#### Relation of Torque to Different Mixtures.

With changing thermal value on increasing speed comes decreasing torque, just as one would suppose. This same phenomenon would follow any similar scheme of procedure, while changing the volume would introduce other complications.

Motors deliver power on a basis as follows:

$$H. P. = S \times T,$$

in which:

The maximum *H. P.* (horsepower) follows; *S* (speed) maximum, and; *T* (torque) maximum.

The torque falls off with increasing speed for reasons as follows:

(a) The richness (thermal value) of the mixture decreases with increasing speed.

(b) The scavenging of the motor is less perfect as the speed increases.

(c) The friction component increases with the speed.

(d) The timing of the spark is more difficult and the ills due to this matter are emphasized.

(e) The torque falls fast if the compression is low, and *vice versa*.

Unfortunately the torque does not hold maximum for maximum speed, and the formula takes this into account, since the maximum power follows, if the greatest sum of speed and torque is taken. Some motors deliver this maximum summation at one speed and many at another. In the author's experience the highest attainable value was found in a racing motor at a speed of 1,800 revolutions per minute, whilst, as a rule, the maximum is realized at about 900 revolutions per minute.

These are matters of deliberate design rather than a chance, since if the valves are of liberal area and the compression is high the greatest power will be realized at high speed, whereas if the valves are small and the compression is low the maximum will be realized at a lower speed. The torque at a low speed will be the most favorable in a motor designed to deliver its maximum power at a comparatively low speed, and the lower speed motor is the most satisfactory for general service.

Broadly speaking, these are not carbureter matters, whilst in detail they surely are, for if a motor is of the high-speed type the carbureter must be designed to do the work on a high-speed basis. The common practice of using a common type of carbureter for all designs of motors in common leads to common results. The gasoline economy is a matter of growing importance, because the price of the commodity is slowly but

surely inflating, and the quality is slowly but surely falling off. Furthermore, motors are increasing in size, and as a sequence economy must follow. Economy demands the use of a carbureter exactly in accord with the motor's characteristics in each individual case, and to know what to do with the carbureter it is necessary to know about the motor. Some carbureters are not provided with hot air passages at all, and such adaptations are not only uneconomical but troublesome.

Motors will deliver more power, start easier and do with considerably less gasoline if the hot air connection is afforded, particularly if the relation of the hot to the cold air is nicely maintained. The mixture will be homogeneous and condensation will be done away with to a large extent. This condensation is most uneconomical and the presence of liquid in the passageways destroys the evenness of the mixture to such an extent as to defeat good running conditions. The depression chamber in a carbureter is a most important part of the device, since upon the depression depends the amount of fuel that can be lifted from the nozzle; moreover, the extent of the spraying will be in a measure dependent upon the same performance.

The depression comes from merely contracting the area of the passageway at the junction of the nozzle, and this area should be in some relation to the area of the cylinder of the motor. The most suitable area is not a matter that has been nicely fixed, nor is it an easy thing to do, since much depends upon the shape of the passageway and the position of the nozzle, if, indeed, the area of the nozzle may not have to be taken into account in this connection. Broadly, the area of the cylinder of the motor may be forty times the area of the hot air passageway at the junction of the nozzle forming the depression chamber. Whilst there is no great proof to bring to bear on the point, the cold air should not be allowed to mix with the rich mixture too quickly, thus giving the rich mixture full scope to become a gas, rather than an aggregation of liquid fuel, in spray form, inmeshed in a current of hot air.

If the cold air too quickly strikes the forming mixture the condensation phenomenon will be in evidence, and this will be fatal to the results. Some claim this is a matter of no moment, if only the manifold connecting the motor with the carbureter is long. More claim that liquid, even in the cylinder, does no great harm, since it will flash into gas in the heated atmosphere. Any such argument is surely resting upon a quagmire, because the liquid in the cylinder will be either extra to the amount required to saturate the air or stratification will be the main phenomenon and to no good purpose.

Dead points in the performance of carbureters must be due to the inability to deliver firing mixtures at all speeds, and the result is, at some speeds, the mixtures are not sufficiently inflammable. This non-inflammability can

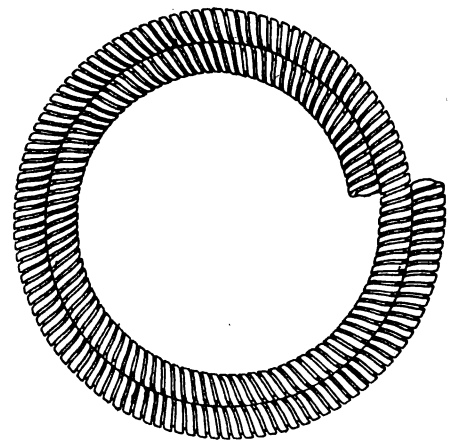

FIG. 3.—Sample of high-pressure gasoline tubing showing its extreme flexibility.

follow condensation, or it may be due to over-much gasoline forming a slow-burning mixture as well as a flash charge, out of the way of which the piston cannot travel in a space of time so short as to render the energy efficient. In such cases popping in the carbureter will be noticeable, and it is a simple sign of impoverished mixture, due to excess cold air, at the point at which it transpires. If the motor performs well at a higher speed, the

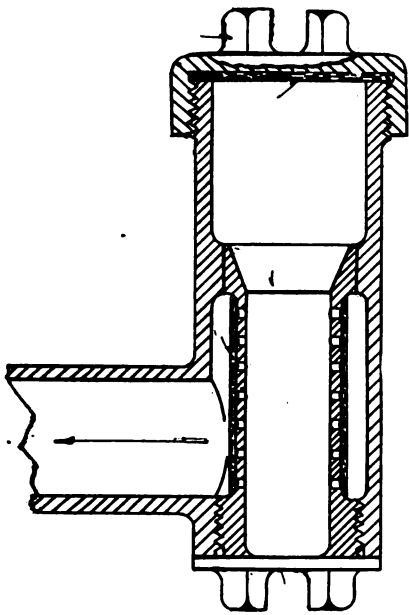

FIG. 4.—Manner of locating filter in gasoline filler vent on the fuel tank.

defect is not serious, but if not, the gasoline supply is inadequate and the area of the nozzle should be increased.

In such a case the mixture will be found inferior for starting and by the introduction of more gasoline the motor will crank better and the speed may be reduced to a lower level, which, in itself, is a good characteristic. If a motor will work well at a very low speed, and at its maximum speed, the carbureter is quite at fault for missing at intermediate speeds. Sometimes the trouble is due to lubricating oil, too much of which reaches the cylinders at certain speeds.

Black smoke (without a gasoline odor) will be the evidence of this; if, however, the odor is of gasoline, excess gasoline is a further complication to be coped with. At all events, the gasoline vapor in a more or less combusted state is not so black and it is always well to eliminate the lubricating oil complication before fighting the fuel trouble.

**Some Modern Tendencies Considered.**

As gasoline becomes heavier, due to the scarcity of the supply of the lighter distillates, the difficulty in rendering the heavier products quick-combusting must be taken into account. One way to accomplish this feat is to employ a detonator, such as acetylene. A very small trace of this gas serves to render slow-burning mixtures, quick-burning instead. This is a good thing to know from another point of view, for if a motor refuses to crank a little of the acetylene gas from the generator used for lighting, led to the air intake of the carbureter, will do remarkable work and do no harm. The idea of adding detonating compounds to the fuel is gaining ground, and this is the most important detail of what are termed synthetic fuel products at the present time. Later on, perhaps, this genera of fuel will assume a greater importance, only if the cost can be reduced or if the cost of gasoline increases considerably over the present cost, not value, as but little consideration is required to show that this is a distinction with not a little difference, although the majority of autoists seldom look at the matter in this light, regarding these terms as practically synonymous.

Besides acetylene there are other detonators, as ammonia nitrate, picric acid, etc. Some of the detonators serve as etching compounds and as a consequence are not desirable, since the cylinder walls would be destroyed as a consequence of their use. Picric acid, for illustration, is used as an etching compound in metallurgy to prepare specimens to be micro-photographed, and the acid in question does not lose its ability to etch the surfaces of iron or steel merely because the shape of the metal is different or because the geographical position is different.

These detonators were used to some extent in racing work and in all probability some races were won on this account. In racing, if it is not foul to "dope" the fuel, it does not matter if the cylinders are destroyed if only they will hang out the race. What transpires in racing does not, of necessity, have anything to do with general practice, although it is a fact that racing has, on the whole, helped to develop the carbureter, if not the rest of the automobile. The fuel problem was undoubtedly advanced under racing conditions, and picric acid certainly did

play a part of some moment. The hydrocarbon products, as benzine, gasoline, etc., must, in the long run, go the way of all temporary expedients; the supply will be totally inadequate.

**Some of the Hydro-carbon Products.**

The products of crude oil vary considerably, even out of the same well, but they change very much for the several localities. The following will give a good idea of the composition of a sample of crude oil.

Above 76° Baumé, gasoline .....	3 per cent.
Between 63 and 76° Baumé, benzine .....	4 per cent.
Between 45 and 63° Baumé, kerosene .....	15 per cent.
Between 38 and 45° Baumé, heavy kerosene.....	8 per cent.
Between 28 and 38° Baumé, gas distillate.....	21 per cent.
Between 26 and 28° Baumé, light lubricating oil....	10 per cent.
Between 23 and 26° Baumé, neutral oil .....	12 per cent.
Between 21 and 23° Baumé, heavy neutral oil.....	6 per cent.
Between 14 and 21° Baumé, reduced stock.....	5 per cent.
Below 14° solid, asphalt .....	11 per cent.
Loss .....	5 per cent.

Total .....100 per cent.

It is a matter of no moment if this particular analysis is high or low in some of the distillates, since, in any event, the amount of usable liquid fuel is but a small percentage of the total under the most favorable conditions. To realize the liquid fuel the whole must be distilled, and the cost of handling the whole product is but one of the factors. Even if it was decided to abandon all but the part available for liquid fuel, the project would come to naught, because all the residue would have to be stored, since no sane community would allow the balance of the product to be dumped into a river or permit it to lay stagnant in a pool near any habitations.

To a large extent the law of compensation takes care of the inequalities, since the crude oil is now used to allay the dust of our roads, hence it may be observed that the automobile increased the demand for liquid fuel and at the same time created a demand for the by-product of the process. Automobiles create road dust and the by-product cements that dust, thus balancing the evils. At all events, it is as plain as can be that gasoline will ultimately have to be superseded by alcohol or a combination of alcohol and gasoline. The combination liquid fuel will, of course, hold some other compounds as detonators, like ammonia nitrate, etc., and acetone, or, what will serve the same purpose, render the synthetic fuel stable.

It would be very hazardous to attempt to use a synthetic fuel if there be any chance of the several products separating, since an increase in the percentage of ammonia nitrate by segregation, for instance, would result in an intense explosive. The author's firm have in hand experiments on this subject, but they are very slow and tiresome, since a full year is allowed ere a mixture is put into service, to make sure it will not decompose, and, in the process, form high explosives. True, it is possible to mix these fuels with some certainty, and it is hoped avoid all high

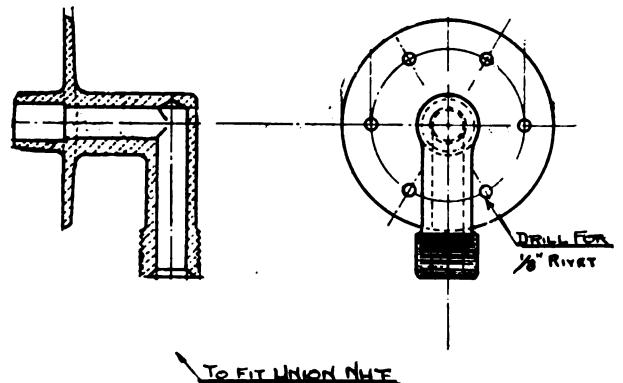

FIG. 5.—Details of fuel tank outlet and manner of application to the tank.

explosive formations, but this has never been the history of investigations into the performance of compounds that hold in their make-up earthquake propensities.

Alcohol alone is not, as yet, all sunshine, nor can it be said the alcoholic fuel will not attack the walls of cylinders, and it may not be out of place to observe the law of probabilities seems to hold in this as in other walks, since alcohol was ever wont to burn the coppers out of all who would insist upon its use. It was supposed motors were imbued with a sufficiently strong constitution to be immune, but there are grave fears on the subject. In the destructive process that obtains in a motor cylinder, especially if pyrolygneous acid is present, and it is likely to be in the wood alcohol, at any rate, the cylinders are likely to be etched by the residue after the motor is shut down unless the last few minutes of the run are made with gasoline as the fuel. To what extent this will be a source of trouble remains to be seen; in time and as the product of experience. True, wood alcohol seems to be the great offender, and to avoid this it may be necessary to avoid its use.

The same carbureter cannot be used for all the fuels as carbureters are at present constructed, because the fuels are not all of the same density nor are all of them of the same thermal value. The floats would have to be adjusted to suit the gravity on each occasion and the nozzles would have to receive attention as well. The motors would not be economical for alcohol

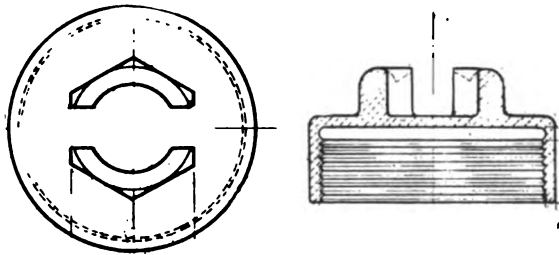

FIG. 6.—Plan and sectional views of tank filler cap, illustrating special nut.

with a compression arranged for gasoline, and, on the whole, it seems the specific fuel will have to be taken into account in designing both the motor and the carbureter. This is not to say a motor designed to use gasoline will not run on alcohol, for it will. The economy will not be good, however, and it would be better to pay far more for gasoline than to use alcohol under such conditions.

It would be feasible to use two carbureters and two tanks for the respective combustibles, if time should prove that necessity will demand the use of a fuel besides gasoline, but it is not now easy to see how the compression can be changed at will (upon changing the fuel) and not introduce much of complication. It is barely possible that the whole matter will take on a favorable turn in the course of time, since there are unbounded possibilities in the field of mixtures of alcohol, gasoline, acetone, nitrates, etc., from which to evolve a satisfactory fuel may only be a matter of time and application.

There is one other point, not yet raised by anyone thus far, that may be of the greatest importance, i. e., air-cooled motors, whilst they serve very well indeed, are nevertheless not yet constructed in the larger sizes, because it is not so easy to keep the temperature within bounds. Alcoholic fuel has a strong bearing upon this phase of the subject, and it is believed the motors will be considerably less difficult to keep cool. One of the reasons for this lies in the fact that this fuel holds upwards of 15 per cent. water, and as water, instead of being a source of heat, absorbs heat, and lowers the temperature of the whole. And again, since alcohol has a lower thermal value per volume at a given pressure, it is plain that the heat at that pressure will be less, and the one deduction is that the cooling requirement will be lower.

With the alcoholic fuel, as before stated, a higher compression is desirable. This is due to the fact that pre-ignition does not take place as it does with gasoline, at an earlier pressure, and the best compression in any internal combustion motor is the highest obtainable compression inside of the point at which pre-ignition and knocking become a troublesome matter. With the higher compression alcohol should do quite as well as gasoline, gallon for gallon of fuel, whilst the higher inflammability and the more complete combustion should end in nearly equal power for equal area of the piston in any given case.

The details in general of the fuel system will not have to be discussed here at any length, because they are fairly understood, but there are points of some moment that will stand more light. Fig. 2 shows a "skimmer," the function of which is to trap off the liquid that may condense in the manifold. The figure is plain enough as to require no length of description. The device is of almost no cost, it takes but little room, and there are no loose parts to become deranged. When the manifold is undergoing design it is perfectly simple to introduce this feature, and it may be a baffle plate in the passageway, between the motor and the skimmer, at a point near the skimmer, would be a good thing to include. The author has not tried this additional feature. Fig. 3 shows a flexible copper pipe for the fuel system that has merit in several ways, amongst which may be cited the ease of installing and the entire absence of any tendency to split. This piping is tight against a pressure of about 1,500 pounds per square inch, and will take bends to about 3 inches radius.

Fig. 4 shows a filter in the gasoline filler pipe that is well worth taking into account, as by its use it becomes unnecessary to bother about the methods used in putting gasoline in the tank. There is no good reason for depending upon the public at large for clean gasoline when a filter can just as well be a fixture in the system. The filter, as illustrated, allows for cleaning at will and when the filter fails to pass gasoline it is time to do something about it; moreover, one can then reflect on what would be the consequences of no filter.

Fig. 1 shows a means of fastening the gasoline tank to the chassis frame, and it may be well here to state that the fastening is an important matter not always given good attention. This fastening shows for itself and has the advantage of a big surface in contact with the copper tank, thus eliminating the chance of having the hangers tear out of their fastenings. The hangers are of 1-8-inch boiler plate and are both light and strong; moreover, they are both easy and inexpensive to make.

Fig. 6 shows a filler cap devised to take a leather packing ring, thus making the joint tight, whilst the leather lasts for a very long time. The most important feature of this cap is that of the hexagon wrench extension (or head). This hexagon extension is slotted in such a way as to allow of the use of a screwdriver or other tool in backing the cap off. It is not always possible to put one's hands on a wrench of the right size for the purpose, and in such cases the slot is a handy facility. Fig. 5 represents a pipe connection to the gasoline tank that is simple, tight and strong. Connections have long been a source of annoyance in gasoline work and it is well worth while to devote not a little extra attention to the installation of this part of the fuel system of any car, as a permanent and well-installed connection between the gasoline tank and the carbureter is one of the first requisites of satisfactory service from this essential of the car. A little neglect here invariably makes its presence felt sooner or later, though the trouble is often most difficult to locate.

In conclusion, it may not be out of place to point out that it is desirable to provide a means for draining the tank at frequent intervals, but it should not be possible for the gasoline to escape through the drain as the result of vibration. A cock is a little inclined to be troublesome in this way, and a plug is, on the whole, the safest thing to depend upon. But it is one thing to have a plug and quite another to use it, and the plug is of small benefit unless used.



# THE INDICATOR DIAGRAM AND WHAT IT MEANS

BY VICTOR LOUGHEED.

IN the periodical and advertising literature of the automobile industry, reference to "indicators," "cards," "diagrams," and "manographs" are becoming increasingly frequent, and though the terms are quite commonplace to the most indifferent engineer, they nevertheless must convey more of confusion than of information to the greater number of automobile owners, whose

technical training hardly averages deeper than the mere ability to pilot a car with a reasonable degree of success.

But the indicator, its relative the manograph, and its

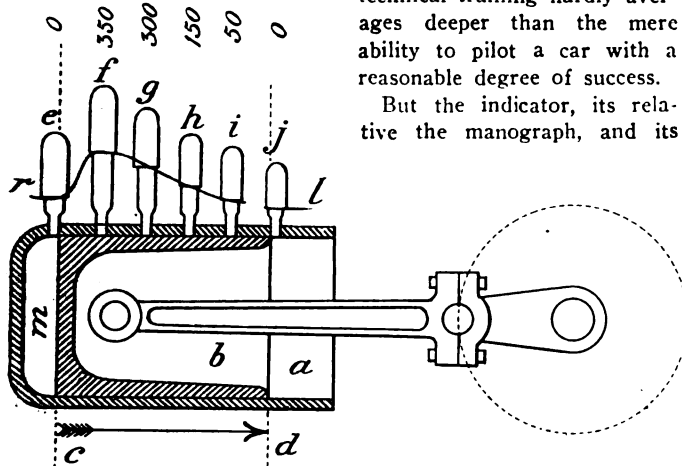

FIG. 1.—Illustrating the theory of the indicator as applied to the gas engine.

product the indicator diagrams, all relate as much to the fundamentals as to the abstrusities of automobile engineering, and there is little reason why a simplified exposition of its construction and purposes should pass any one's understanding. Beginning with elementary automobile engine principles, it is, of course, understood that the piston is impelled from one end to the other of its working stroke by the pressure of a mixture of air and fuel vapor highly heated by the reaction from a chemical combination (combustion) of its elements. This pressure is highest at about the commencement of the stroke, before the heat of combustion is partially lost into its surroundings, and before the pressure is reduced by the heat loss and the expansion permitted by the moving piston. The pressure is lowest at the termination of the stroke, by which time the available energy of the charge is utilized and it is ready to be exhausted, that its place may be taken by a fresh, unconsumed charge. At intermediate points in the stroke the pressures are of intermediate values, the drop occurring at a rate variously determined in different engines by the quality of the fuel, the timing of the ignition, the piston speed, etc.

Taking another leaf from elementary principles, it is pretty generally known—from the very definition of the term—that the horsepower of any given engine is the product of its piston area multiplied by the pressure in pounds upon it, multiplied by the working travel in feet per minute, and divided by 33,000. However, as has been pointed out, no internal-combustion engine operates with a uniform pressure throughout the stroke; it becomes necessary for purposes of calculation to take into account the number of working strokes in a given time, and to ascertain the "mean effective pressure" that substantially represents the total of the work done in each stroke.

To illustrate, consider the case sketched in Fig. 1. In this *A* represents the cylinder and *B* the piston of a horizontal automobile engine, the working stroke being accomplished to the right—from the dotted line *C* to the dotted line *D*—the piston head as shown being aligned with the line *C*, ready to commence a power stroke. The pressure at different points in the stroke, as it would be shown by a plurality of small maximum-pressure gauges *e f g h i j*, screwed into holes in the cylinder wall and uncov-

ered one after another as the piston progresses to the end of its stroke, would be about in accordance with the figures printed above each gauge, in an average engine. If the gauges could be infinite in number, this would give a curve for the pressure rise and fall closely approximating the dotted curve *r l*.

A little further reasoning quickly discloses the fact that a plurality of gauges is not necessary if with one gauge it is made practical to record accurately and positively all of the fluctuations in pressure from the beginning to the end of the stroke—so that it could be known, for example, that at the beginning of the stroke the gauge had registered zero, one-half inch further on had registered 350 pounds, by another half inch 300 pounds, and so on to the end of the stroke. Obviously, too, to use a single gauge it must be attached to the head of the cylinder, that it may be at all times in communication with its interior, instead of having to be uncovered by the movement of the piston. In this connection it is well to note that the arrangement of gauges shown in Fig. 1 would be necessary only to insure their proper successive action, and not because of any variation in pressure in different portions of the chamber *M*, which becomes larger as the piston recedes, while the pressure drops throughout it.

The conditions to be fulfilled by an indicating device being defined, its mechanical construction might reasonably appear to take the form sketched in Fig. 2, in which *A* is the cylinder, *B* the piston, *C-D* the stroke length, and *E* a pressure gauge permanently in communication with the combustion chamber *M*. Forming a part of the gauge, the plunger *N* is adapted to rise and fall in proportion with the pressure, from zero to the maximum that is likely to be encountered—a range that will be from the dotted line *O* to the dotted line *P*. In the T-shaped top of *N* the rod *Q*, carrying a pencil point at *R*, is arranged to slide horizontally from *C* to *D*, the stroke length of the engine, it being pulled through this distance by the string *S*, affixed to the light standard *T*, bolted to the piston. Behind the pencil there is firmly mounted the card *U*, wide enough and long enough to accommodate the full possible travel of the pencil, both vertically and horizontally. Everything being arranged as shown, it can be easily perceived that the dotted curve *R E*, similar to that indicated by the same letters in Fig. 1, must be generated by the compound movement imparted to the pencil by the pressure gauge and the spring.

The whole principle of the indicator having been explained, its practical application and the utility of the

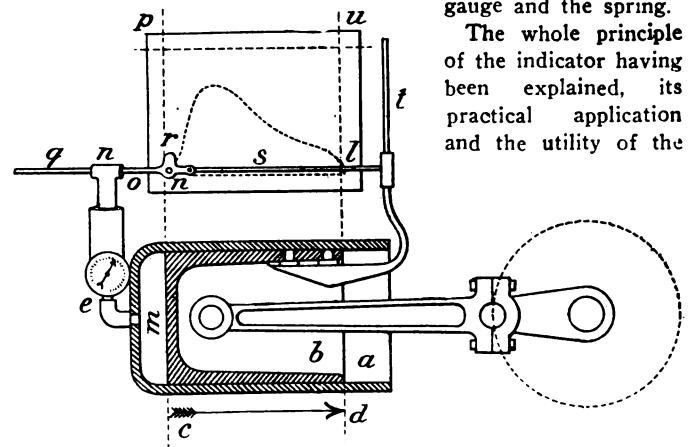

FIG. 2.—Crude form of gas-engine indicator, showing its component parts.

diagrams from it call for further comment. First, it must be understood that it is scarcely practicable to use on most engines so crude a contrivance as is employed to illustrate the principle in Fig. 2. In most indicators the dial portion of the gauge (*E*, Fig. 2) is omitted and all possible care in the design and construction of the device is de-

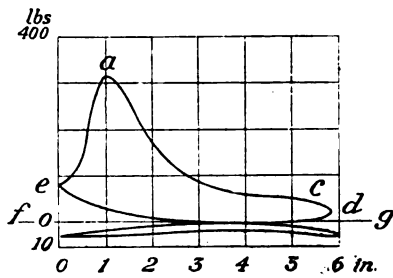

FIG. 3.—Specimen of typical gas-engine indicator card showing exhaust and compression.

engine. This is conveniently effected in most good indicators by wrapping the card about a cylinder, which is revolved to secure the horizontal traverse, while the vertical movement is by means of a multiplying action magnified into a more readable exaggeration of the plunger movement. Still another element involved by considerations of practical utility is some provision for automatically throwing the whole service in and out of action for one or some other predetermined number of strokes, while the engine is kept running at a uniform speed.

Several typical automobile-engine indicator diagrams are shown here. In each case these are made to occupy at least the full number of strokes required to complete the engine cycle. Fig. 3 is from a four-cycle engine, the top line showing the explosion, the next to the bottom line the exhaust, the bottom line the suction, and the next to the top line the compression stroke. This card is from an engine of the common type, working efficiently at its best speed, and its explosion line shows very clearly the enormously rapid rise of pressure after ignition, up to the peak *A*, from which maximum there is a gradual fall to *C*, where the exhaust valve opens, causing the abrupt drop to *D*. In the compression stroke the pressure is seen to rise at an increasing rate to *E*, where ignition occurs, and whence the rapid rise to *A* commences. It will be observed that most of the suction stroke and a portion of the compression stroke fall below atmospheric pressure, which corresponds to the line *F G*.

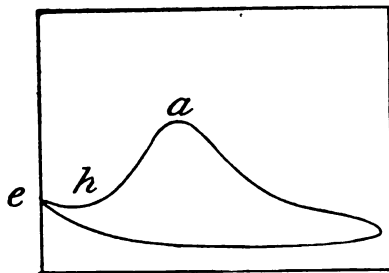

FIG. 4.—Illustrating the effect of late ignition on the power produced.

The mean height of the explosion line of a diagram gives the mean pressure. From this is to be subtracted the negative work imposed during suction, compression and exhaust. For practical purposes, with a correctly adjusted engine, the power consumed in the suction and exhaust strokes is too small to be considered, leaving only the compression to be subtracted. The simplest way to realize this subtraction is to disregard the space below the compression line, leaving that between the compression line and the explosion line to be regarded as the "work area" of the diagram. This area, redistributed into a rectangle corresponding in length to the stroke, will have a height commensurate with the mean effective pressure, from which the power output of the engine can be readily calculated. In specifying a basis for horsepower ratings, the German Government

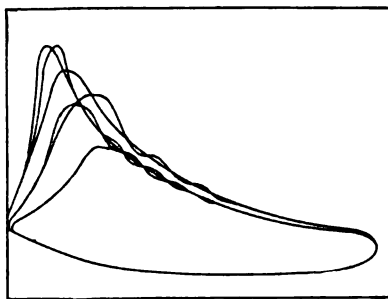

FIG. 5.—Several superimposed diagrams, showing effect of throttling.

decrees that 55 pounds to the square inch shall be taken as the mean effective pressure in automobile engines. Few, if any, internal combustion engines of any type whatsoever have realized mean effective pressures as high as 90 pounds to the square inch. The diagram Fig. 4 is from the same engine as is the preceding case, and is of interest chiefly because it shows how ignition delayed to *H* causes a lowering of the peak *A* and a loss of work area throughout the entire diagram. The failure of the explosion line to run directly back upon the compression line to *H* is explained by the absorption of heat from the cylinder walls. It is further to be noted in Fig. 4 that the scale of pressure at the left of the card and the scale of stroke positions across the bottom of it are not present as in Fig. 3. This is because the usual requirement is for data comparative only with respect to the different portions of the diagram itself, and not with regard to arbitrary scales of pressure and of stroke dimensions. The card shown at Fig. 5 shows how by a maintained application of an indicator a number of superimposed diagrams may be secured, showing most graphically just what occurs when an engine is throttled down.

At Fig. 6 the card shown is from a two-cycle engine, so there are only the compression and the explosion lines to be seen. A typical card from a steam engine is shown at Fig. 7. This card presents marked contrasts to the gas-engine diagrams. All strokes in both directions being power strokes, one complete revolution of the crankshaft produces the two reversed diagrams given. Moreover, the pressure is maintained at its maximum for nearly half the stroke, to a point at which cutoff of the motive fluid occurs and is further accompanied by expansion of the motive fluid down to atmosphere.

Internal combustion engines of all classes have been for years regarded as most difficult subjects for indicator research, and until within recent years the application of the device has been all but confined to steam engineering. This has been because the pressure fluctuations within gas-engine cylinders are of such great amplitude, and occur with such suddenness and violence, as to make it almost impossible to devise mechanism with parts light enough to act as quickly as is required, and at the same time strong enough to withstand the shocks imposed. As a matter of fact, practically all successful results in indicating gas engines have been obtained through the use of the strictly modern manograph—a modified type of indicator in which there is substituted for the pressure gauge a spring controlled circular diaphragm, which in conjunction with the piston movement exercises a compound control, in the form of vertical and horizontal oscillations, over a small circular mirror.

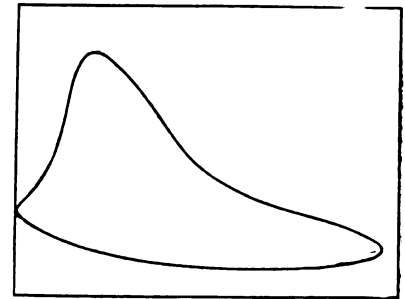

FIG. 6.—Indicator card from a two-cycle motor, omitting exhaust and compression lines

As a matter of fact, practically all successful results in indicating gas engines have been obtained through the use of the strictly modern manograph—a modified type of indicator in which there is substituted for the pressure gauge a spring controlled circular diaphragm, which in conjunction with the piston movement exercises a compound control, in the form of vertical and horizontal oscillations, over a small circular mirror.

As a matter of fact, practically all successful results in indicating gas engines have been obtained through the use of the strictly modern manograph—a modified type of indicator in which there is substituted for the pressure gauge a spring controlled circular diaphragm, which in conjunction with the piston movement exercises a compound control, in the form of vertical and horizontal oscillations, over a small circular mirror.

As a matter of fact, practically all successful results in indicating gas engines have been obtained through the use of the strictly modern manograph—a modified type of indicator in which there is substituted for the pressure gauge a spring controlled circular diaphragm, which in conjunction with the piston movement exercises a compound control, in the form of vertical and horizontal oscillations, over a small circular mirror.

As a matter of fact, practically all successful results in indicating gas engines have been obtained through the use of the strictly modern manograph—a modified type of indicator in which there is substituted for the pressure gauge a spring controlled circular diaphragm, which in conjunction with the piston movement exercises a compound control, in the form of vertical and horizontal oscillations, over a small circular mirror.

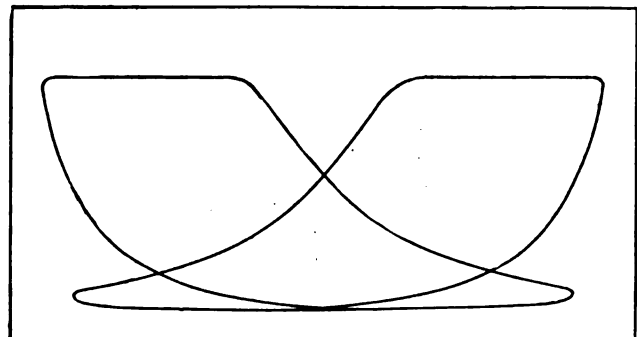

FIG. 7.—Typical double-acting steam engine, or "flat-top" card, illustrating how the pressure is maintained for a very large portion of the stroke.

# A NEW STEP IN MAGNETO DEVELOPMENT

By ERNEST COLER.

THE observation that the average chauffeur seldom likes to "dope out" magneto ignition systems applies with even greater force to the owner, whose principal objects in making use of the motor car are the saving of time, the attainment of comfort and the pursuit of pleasure.

All repairmen will agree that even the well-paid and presumably more than ordinarily intelligent chauffeur, after a general overhauling job, experiences considerable difficulty in getting the magneto to function as well as it did before he laid his dissecting finger upon this part of the mechanism. Many chauffeurs who are able to solve the mysteries of the four-unit coil circuit are completely at sea with the average magneto. The new magneto systems to be described in this article are the invention of Robert Miller, M.E., of New York, another of whose inventions—the gearless friction transmission—was described in the issue of November 14; they are of the pure high-tension type and differ from other magnetos principally in that they are in frictional contact with and driven by the flywheel or by belt, and revolve, in one system, at a rate approximately six times faster than the engine. The number of sparks produced is six per magneto revolution, so that the total spark production is 36 sparks during each revolution of the engine. In this respect the arrangement corresponds somewhat to the action of a single coil, vibrating all the time and distributing the secondary circuit to the various cylinders.

If this sparking cycle be divided into the degrees of the crank cycle it will be found that they are spaced about ten degrees apart. Objection might be made that the ignition in a multi-cylinder gasoline engine thus operated would not be synchronous; that is, the moment at which sparking begins might be later than indicated by the distributor. Ten degrees, the maximum possible variation, is a very short distance measured in the length of the stroke, especially around the dead center. However, in comparing the Miller system with the four-unit coil system it will be seen that the action of the four coils is anything but synchronous; in other words, the four vibrators cannot be tuned alike, and there are inevitable variations, even greater than ten degrees, in the timing of the spark. Likewise in using the four-unit system with the modern addition of the master vibrator, it is easy to demonstrate that although the vibrator action is the same for all four coils, this arrangement lacks every guarantee that the four coils will be in equal electrical balance or continue so for any definite length of time.

With the use of the Miller magneto the engine is started in the usual manner by cranking, or the magneto may be rendered self-starting, as will be explained later. With the new magneto it is unnecessary to "spin" the engine in order to turn the magneto sufficiently rapid for effective sparking, because of the fact that even with a slow turning of the cranking handle the magneto will revolve much faster and will produce the desired ignition.

The magneto has a vibrator, condenser and low-tension coil for starting at slow speed only, and as the engine attains a certain predetermined speed these are cut out automatically and eliminate in this manner the necessity for continued use of the attachments. Simultaneously with the cutting out of the vibrator

the high-tension coil alone is used and acts as the simplest kind of high-potential alternating current generator, in which neither moving wires nor contacts are employed.

It can readily be seen that the operation of this magneto offers no problems whatever to the inexperienced driver, because the need for his attention is limited to seeing that the friction wheel of the magneto is in contact with the flywheel, and that the sparks occur under the glass cover of the distributor, which is made in the most approved style, non-wearing, with the contact points separated by a small gap. In fact, should sparks not appear at a distributor point it is evidence that either the corresponding plug or its connections are at fault.

The current is generated by means of inductor pieces fastened to a shaft running on Hess-Bright ball bearings, which require very little attention, being packed in grease. The magnetic core of the coil is bent around so as to come within the field of the inductor pieces. These inductor pieces, in revolving, change the magnetic flux through the coil, the magnetism leaving the magnet at the north end, going through one inductor piece, up and over through the iron core of the coil, down on the other side through the corresponding inductor piece, which leads it to the south pole, the flux varying at different positions. This is more clearly shown in the accompanying drawings.

With 36 sparks produced every revolution of a four-cylinder engine, the sparks are distributed so that one-half of them enter each cylinder during each explosion stroke, with the result that in the four-cycle type, even should the first spark fail to ignite the mixture on account of imperfect carburetion, etc., the next spark, coming only ten degrees later, is certain to fire the charge, because the charge itself has become hotter and more readily ignitable through longer contact with the hot cylinder walls. In this manner it will be impossible for the engine to pass unignited charges into the muffler, there to explode. The plurality of sparks also exercises a cleaning effect on the spark plug terminals.

The distributor is, in this case, made to time the 18 successive sparks for each cylinder of the four-cylinder four-cycle engine, or 12 sparks for the six-cylinder engine. Of course, it is possible with this magneto to use the ordinary type of distributor, in which a timer in the primary circuit controls the action of the secondary circuit, but the type illustrated herewith is simpler and less apt to get out of order. In experimenting with the new magneto Mr. Miller has made a series of trials and pro-

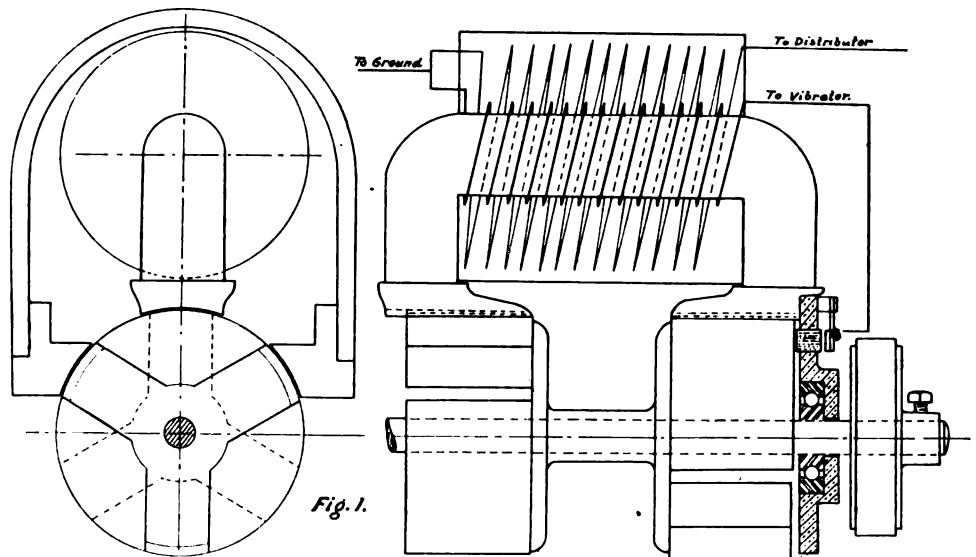

FIG. 1.—End and side elevations of the new Miller magneto, showing disposition of the windings.

duced many forms of inductor pieces and cores for the coils, in some cases going so far as to make the cores of a non-magnetic shell filled with finely divided or chemically reduced iron with which a quick magnetizing and demagnetizing action may be obtained.

The illustration shows that the coil is the same as used with battery circuits, having vibrator, condenser, etc. Although a safety spark gap is provided, in case of damage a new coil can be inserted quickly and at very low cost, doing away with the expensive pulling down of the entire magneto and rewinding of the armature. In Fig. 2 the magneto is shown altered, so that each limb carries a smaller induction coil, connected in series. The cost of the Miller magneto can be made alluringly low, and it may be placed even in the low-priced runabouts, a selling price of from \$30 to \$35 being probable.

The self-starting arrangement is as follows: The distributor, which, of course, is controlled by the hand lever on the steering post, is brought to the proper position, as is now done with the four-unit coil systems, and the magneto shaft is given several quick turns by means of a small spring motor incorporated in

sign somewhat, with results even more interesting than those already enumerated. The same general scheme of stationary wires, with revolving inductor pieces, is used, but the rate of speed is confined to a maximum of 2,000 to 2,500 revolutions a minute; the friction wheel in this case is smaller and controlled by a governor such as is much employed on small dynamo sparkers. The result is that only a few sparks per engine revolution are produced, of a correspondingly greater angular variation.

To insure proper timing of this system, the high-tension wires feed into a Leyden jar set in the magnet arch above the coil, and are there held until this jar is discharged by the distributor. In order to make it possible for the Leyden jar, which is a modified condenser, to be charged and yet not discharged as the current potential falls away, what is essentially an *electrical check valve* is interposed in the circuit.

The coil generates current up to about its maximum pressure; connection is made with the Leyden jar, which becomes charged; the connection is then broken, and as both coil and jar are of the same potential no current passes from the jar. At the proper moment the distributor rotor on the engine gets in position and makes a path through which the jar can discharge.

Those familiar with the rapidity of the discharge oscillations of the ordinary condenser, as used with the primary windings in induction coils, will appreciate the impulsive force with which the Leyden jar discharges itself. Such impediments as soot, oil, water, etc., on the spark plug points have no influence whatever on the action of this spark; even external short circuits of a moderate extent are powerless to divert it from its proper path. This is due to the enormous difference in the discharge rate of the high-tension coil and of the condenser; it has been estimated that the latter discharges at a rate of from 1,000 to 4,000 as great as the former. We have here, in fact, the action of the lightning stroke on a small scale. The entire coil, with connections and Leyden jar, can be sealed up in paraffine or pitch, so that only the weather-proof spark is exposed. Instead of glass, other insulators, not liable to breakage, can be used.

Of course, the first system is simple and perhaps more adapted to be used by the unskilled driver; yet it is clear that the latter system possesses a number of distinct and noteworthy advantages.

### TO THE MAKING OF THE MOTOR MECHANIC.

Austrian automobilists are watching with much interest a project which promises to provide efficient repair shops and skilled workmen for making automobile repairs throughout the country districts, facilities which have hitherto been sadly lacking outside of the cities and towns. The Auto Technical Association is organizing a training school for automobile repair work in the rooms of the Handicrafts Exhibition. It is especially intended for country blacksmiths, locksmiths and other mechanics with a knowledge of machinery, and, besides helping to provide automobile repair shops in country places, the school will open up a new means of livelihood to these workmen, many of whom have lost a good deal of their original business through the introduction of the automobile. The school will be completely equipped with tools and all requisites for the work of repairing cars. The course of instruction will last four weeks. Special provision will be made for the admission of workmen in poor circumstances by the grant of a small pecuniary compensation for the time spent in the school.

Widespread use of the automobile in cities has been accountable for a change in the habits of more than one city dweller, but neither the inherent keenness of vision nor the great agility of its feathered denizens who find their living in the streets is quite able to cope with the car's silent and rapid approach, and the result is more than one dead pigeon that could easily have escaped the swiftest horse.

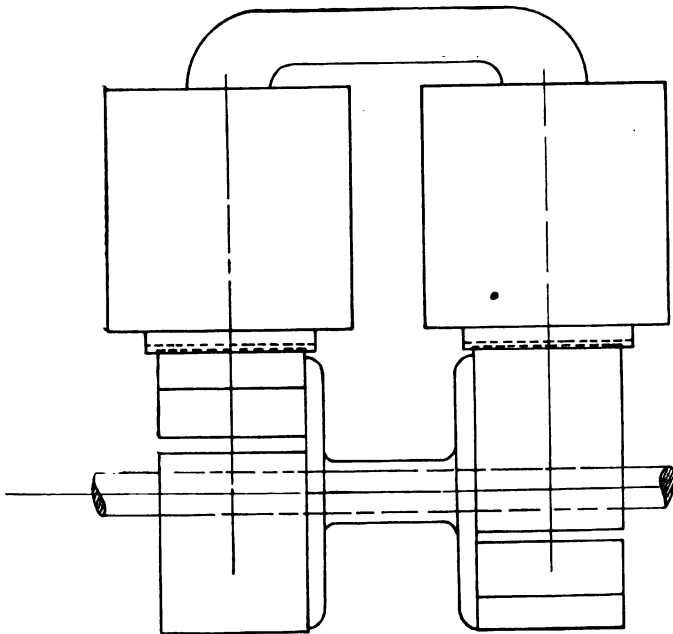

FIG. 2.—Illustrating arrangement of windings in proposed modification of generator, each pole carrying a separate coil.

the hub of the friction wheel. The spring motor is wound by the action of the engine; to self-start, it is released, to be re-wound as the engine takes up its motion. Another alternative is to give the magneto shaft a couple of quick turns by means of a multiplying device placed on the dash. Spark advance and retardation is taken care of by altering the position of the distributor, as is now done with the low-tension timers used in the multiple-unit systems. Of course, where occasion demands, the placing of the coil in relation to the magneto or to the inductor pieces could be changed; it is believed, however, that the arrangement shown offers many advantages over the usual placings.

#### A Highly Interesting Modification.

The objection might be made that for small cars of low power the device described in the foregoing would consume a measurable proportion of the power output; although the sparks are more numerous than in the ordinary magneto, yet the magnets are so proportioned as to give only about the equivalent magnetic saturation to the core that is given in the usual battery systems. The electrical pressure in this system is the result of the rate of line-cutting rather than of the intensity of the magnets themselves.

To overcome this objection, Mr. Miller has modified his de-

## LETTERS INTERESTING AND INSTRUCTIVE

### IS THIS FAULTY CARBURETER ADJUSTMENT?

Editor THE AUTOMOBILE:

[1,057.]—In your issue of December 12, I notice letter No. 1,012, which case I believe applies somewhat to my car, which is a two-cylinder (Buick), which I have great trouble in starting, despite the fact that after it is in operation, it runs very smoothly and has very high power. The carbureter is a Schebler, which is at the end of a piece of brass tubing, close to the end of the engine. This tubing has a drop of 6 inches in a 2-foot length, terminating in a "Y," which branches off to two tubes, one running to each cylinder. There is a drip hole at the bottom of this "Y," and oftentimes, no matter how carefully I set the carbureter, clean gasoline will drip out of there. I have been bothered with it more or less for some time, as it seems impossible to get it accurately set so that it will give satisfaction at all speeds, so that I am compelled to throw the gasoline off at the bottom of the tank every time it is used, to prevent it running down the pipe and leaking out of the drip hole. This is despite the fact that I have adjusted the carbureter very carefully and it does not begin to leak for some time after the engine has stopped. As the "Y" is directly under the flywheel, it would be a very bad place to locate the carbureter. In fact, there is hardly any place in which the carbureter could be located where it could come lower than the "Y" and be accessible. If you can advise me of a new way to pipe up the intake so as to do away with this, I shall appreciate it. The machine is a Model F Buick, of 1906 make, and has given absolute satisfaction in every way but this, often showing more power than larger four-cylinder cars with much more powerful engines.

Louisville, Ky.

R. S. HILL.

In view of the fact that large numbers of the type of car you mention are in daily use, it would seem quite probable that if the trouble you complain of were due to an inherent defect in the design, such as would require the replacement of the intake manifold, complaints on this score would be more common. On this account it seems more than probable to us that you will find the fault in the adjustment of the carbureter. If gasoline begins to drip out, even though only after the engine has been stopped for some time, this would indicate that the float level is too high, thus permitting the gasoline to overflow the moment the fuel reached it. The constant demand upon it by the engine while running prevents it overflowing at other times. The fault may not lie so much in the adjustment as in the fact that the float may have become loggy, if cork, thus sinking somewhat and raising the gasoline level to a corresponding extent. As you are located in a large city, you should be in a position to get in touch with other owners of the same make of car and ascertain if they have the same difficulty. Also consult the agent of the car and look at later models of the same car, to see if the manifold arrangement has been altered in any way. Even the designer only learns by experience where many of these details are concerned and if the trouble has been due to faulty design you will doubtless find that it has been modified to suit the requirements. The maker will also doubtless be glad to be of assistance, if you write the factory stating the nature of your trouble. The same effect is frequently due to totally different causes, so that it is not always safe to jump to the conclusion that the same remedies will be equally effective.

The difficulty in starting may be due to any one of a number of different causes, but judging from the outline you give an overrich mixture would appear to be responsible. The liquid gasoline collecting in the drop of the manifold fills the latter with practically pure gasoline vapor, which will not ignite even under the most favorable circumstances. There is so much of this vapor present that cranking several times does not suffice to clear the passage and introduce enough air to form a mixture. As soon as the cranking ceases for a few moments the manifold refills, thus maintaining practically the same condition. There should be a stop cock placed in the gasoline line from the tank to the carbureter so that the supply could be shut off at any time. This would avoid the necessity of emptying the tank.

### LAYING UP STORAGE BATTERIES IN WINTER.

Editor THE AUTOMOBILE:

[1,058.]—Will you kindly tell me in your next issue which is considered the cheapest and best way of taking care of Vesta storage battery for the winter? The garage in this city tells me to saw the plates apart. It is all Greek to me, but I understand it is practically tearing the battery to pieces and soldering it together again in the spring. On the other hand, they want to charge a dollar a month to store it and run it down. I don't find the battery advertised in your journal and do not know where their factory is, so therefore write you for suggestion.

Duluth, Minn.

DR. F. C. LEE.

It is evidently worse than Greek to the garage keeper who advises you to saw the elements to pieces. This would practically mean ruining the battery, as it would have to be returned to the makers to have the connections burned together again. They are joined by lead burning, not by soldering, and we cannot conceive where the garage keeper got his idea that it was necessary to disconnect the plates. The charge for storage is likewise excessive, unless it be intended to recharge it every fortnight, which is one method of keeping a battery. Where this is not convenient it is not a difficult matter to take it out of commission so that it may again be used in the following spring with little or no trouble in reassembling. First, have it fully charged and then remove the elements from the jar and separate them. That is, lift the positive group of plates away from the negative. There is always one more plate in the negative than in the positive group, though they may be readily distinguished otherwise by the marking of the elements with minus and plus signs, respectively. After charging and removing from the jar, wash the positive thoroughly in clean, soft water and allow it to stand immersed for an hour or so in order to be certain of removing all the electrolyte. Do the same with negative, and when dry the positive element may be stored in any convenient place where it will not come to harm—preferably in a cool and dry situation. Should the negative become warm and steam while drying, rinse in water again. When thoroughly dry, the negative should again be immersed in the electrolyte of the proper specific gravity, i. e., 1.275 to 1.3, and allowed to remain for several hours, care being taken to see that the plates are entirely covered. It should then be lightly rinsed in water, dried and stored, the same as the positive. The separators and other small parts of the cells should also be thoroughly cleaned in soft water and put away after drying. Where worn or cracked, as in the case of wood separators after long service, it is advisable to replace them.

### CONCERNING A NEW DRAGON ROADSTER.

Editor THE AUTOMOBILE:

[1,059.]—I inclose herewith small drawings of a Dragon Roadster, which I recently purchased at the Chicago show. I am particularly anxious to find out what the horsepower rating under the A. L. A. M. would be. At the given weight of this car, will you kindly advise whether or not you should have this car geared 2 1-2 to 1, or 3 to 1, in view of the fact of its having but two speeds and would be used here in St. Paul where we have a number of grades for daily use of from 9 to 12 per cent.?

St. Paul, Minn.

DRAGON.

The indicated horsepower of the engine of the car you mention, as calculated under the A. L. A. M. formula, is 36.4 horsepower. We should recommend the 3 to 1 gear ratio as being better suited for all-around work, particularly in a hilly district, and more especially in view of the fact that there are but two forward speeds. The power of the car is high for its weight and should enable it to mount pretty stiff grades on the direct drive and at quite a speed. As a 32-inch wheel covers approximately 8.3 feet per revolution, it would give the car a speed of about 31 miles an hour at 1,000 r.p.m. of the motor, or 46 to 47 miles an hour at 1,500 r.p.m., with a 3 to 1 gear ratio.

Raising the latter to 2.5 to 1 means that the road wheels would make a complete revolution, omitting all considerations of lost power or road slip, for every 2 1-2 turns of the crank-shaft, which would give the car speeds of 38 and 57 miles an hour, respectively, at the different motor speeds mentioned. It will be evident that these speeds are excessive for any ordinary requirements and there would be few opportunities to use them with safety, while they would, moreover, make the car too speedy for city work, which would mean that the motor would have to be run throttled down continually or the clutch slipped. In other words, it would require more manipulation to handle the car in traffic. The lower gear ratio, *i. e.*, 3 to 1, would permit the motor to be run at a better speed and would not impose as severe service on it in the long run.

#### AN EXPENSIVE REMEDY FOR CLUTCH TROUBLE.

Editor THE AUTOMOBILE:

[1,060.]—I have been having considerable trouble with a slipping clutch, which is leather to metal. I am informed by my machinist that this has two causes.

In the first place, that there is not thick enough leather on the clutch, and, therefore, it gets very hard, and, secondly, that the clutch is too much cone-shaped, and that if I lessen the cone it will grip better. He explains that this can be done by turning 1-8 of an inch off the smallest diameter of the flywheel, and building up the leather on the clutch. The clutch now has a 4-inch bearing surface, and in that 4 inches there is a cone of 1-2 inch. He suggests lessening this to 3-8 inch. Is he right in what he says?

On the cardan shaft of my car, between the clutch and the gear box, there are two movable joints, which, if they were placed at right angles to one another, would make a universal joint, but I note that both joints move in the same direction, that is, the axles in both joints are either pointed to the right and left, or up and down, both being in the same position at the same time. Surely there has been a mistake on the part of the man who assembled it, and these two joints should be at right angles, so that when one is moving from right to left, the other could move up and down.

The two joints I alluded to are (as I said) between the clutch and the gear box, and about one foot apart. There are two similar joints behind the gear box, between it and the differential, and they are exactly in the same relative positions, that is, the axles of both joints are always pointed in the same direction. I conclude that those are also wrongly assembled.

I will be very much obliged for your opinion on this matter, as I think there has been a mistake made in the assembling of the shaft, for they have no resemblance to a universal joint in the position they are now in.

I am advised by a French driver that neatsfoot oil is better for use on leather than castor oil, that is, that it softens the leather better, and is less of a lubricant. Is he correct?

Toronto, Canada.

CHAUFFEUR.

Before adopting the advice of the chauffeur it would be advisable to consider the matter from every point of view. If his suggestion be correct, then it must be inferred that the clutch was poorly designed from the outset and never was right. Your experience with the car should enable you to answer this one way or the other. If you have had trouble of similar nature ever since you have had the car, then it would appear that probably the design was at fault. But if the car performed satisfactorily for a considerable period of time and has only been giving this trouble more recently, would it not seem to be jumping at an unwarranted conclusion to decide offhand that the design was wrong? We see nothing radically wrong in the figures you mention and while turning the conical face of the female member of the clutch down to an easier angle might effect a more gradual engagement it will not prevent slipping, other things remaining the same. Hence we do not agree with your driver. Building up the leather is only a makeshift and will not prove satisfactory. In fact, it is much more apt to prove otherwise, for reasons that will be obvious.

That the leather gets very hard does not necessarily prove that there is insufficient of it on the clutch to do the work. It merely goes to show that the clutch is frequently slipped, as it is the friction created that hardens and polishes the leather. How about the adjustment of the clutch itself and its seating spring?

If the leather facing appears to be too thin, moving the clutch slightly further into engagement and strengthening the compression of the spring should afford a remedy. If this trouble with the clutch be chronic, and not due to poor adjustment or poor driving, we should advise doing away with the leather facing entirely and substituting cork inserts, thus making it a metal to metal clutch. This would be far more satisfactory and doubtless far less expensive than the remedy your driver suggests. Regarding the question of oils, we have had no experience with neatsfoot in this connection and cannot advise; castor oil is very largely employed for making leather belts adhere to metal pulleys in factories and shops.

We find it impossible to recognize the particular type of universal that you refer to from your description, nor do you state whether the car has just been reassembled after dismantling or whether it has been run with the joints in this condition. Can neither your driver nor the garage attendants tell you whether the joints have been wrongly assembled or not? Reference to the maker's instruction book should shed some light on the matter.

#### THAT HARDY PERENNIAL ONCE MORE ON DECK.

Editor THE AUTOMOBILE:

[1,061.]—Will you please let me know through your columns if the inside or outside wheels of an auto taking a curve at great speed leave the ground? Does the same apply to a locomotive?

New York City.

TIMOTHY P. GUINEE.

The inside wheels of any four-wheeled vehicle tend to leave the ground when rounding a curve at high speed for reasons that must be plain on a moment's consideration. It is on this account that the outer rails of a track are elevated. Assume a vehicle, such as an automobile, to be traveling at high speed in a straight line. The car, with its load, weighs 4,000 pounds, or two tons, and is traveling at the rate of fifty miles an hour. It will be evident, then, without going into the mathematics of the subject, that the force represented by this traveling body is little short of that of a huge projectile which has just left the gun; and it must be evident that this tremendous force, thus exerted in a straight line, cannot be turned from its path in violation of natural laws without serious consequences. In other words, the moving body has a very strong tendency, proportionate to its speed and weight, to continue traveling in a straight line, and in order to take a curve safely it must be counteracted to a point where there is no danger of the inside wheels of the vehicle leaving the ground to an extent that would make overturning imminent. Consequently, curves are banked and speed is reduced in rounding them. The effect of the former is to bring the center of gravity of the moving body on a line with the inside wheels, thus concentrating the entire weight on that side to prevent its being lifted by centrifugal force. The most common manifestation of the action of the latter is to be seen in the manner in which the passengers are moved bodily toward the outer side of the car in a train rounding a curve at high speed. There are some autoists who are quite certain that they have seen the outer wheels of an automobile leave the ground when it was rounding a curve, and who stick to their theory of the matter despite all explanations to the contrary, but they doubtless never paid any attention to this action while riding in a train or in the tonneau of an automobile, where it is very much more pronounced.

#### TROUBLE WITH A LEATHER-FACED CLUTCH.

Editor THE AUTOMOBILE:

[1,062.]—I have been a subscriber to your publication for several years and shall appreciate your advising me through your "Letters Interesting and Instructive" as to the following: In the timing of an engine, I thoroughly understand that if the two to one gear is slipped one cog either forward or backward, it will change the timing of the engine, either later or earlier. If this is done, can the correct timing be made again with the commutator, pushing it forward or backward? I am having some trouble with the cone leather-faced clutch, it engaging too much. It



has three spiral springs in the male part of the clutch, which press upon the leather when engaging in the flywheel. I put three thin pieces of brass under each spring, thinking to remedy the trouble, but it made them worse, so I took it out, but I still have the trouble with the clutch catching too quick. I have tried oiling the leather with ordinary lubricating oil, but it seems to have no effect. I, however, note in one place that the spring is worn through the leather. Would this cause the fault, or would you advise relining the clutch? How would three cork inserts do?

J. G. S.

Louisville, Ky.

Upon a little consideration of the matter, it will be apparent that the relative position of the contact in the timer, with reference to that of the piston of the cylinder to which it corresponds, is the essential aimed at in timing the ignition of a motor. Consequently, it is immaterial whether an alteration in the relative positions of these two parts be brought about by altering the relation of the driving gears, or the position of the timer itself on its shaft, so that moving the latter will naturally compensate for shifting the gears.

It seems evident that the fact of the springs having worn through the leather facing is responsible for the rapidity with which the clutch takes hold, as these points are naturally higher than the remainder of the male member of the clutch and consequently come in contact with its seating sooner than intended. Cork inserts would be far preferable to merely relining the clutch, as it was previously, and would improve the action and service of the clutch in every way. We should advise corresponding with maker of the car, or the manufacturers of the cork inserts before proceeding.

### ENGINE WITH UNJACKETED HEADS RUNS HOT.

Editor THE AUTOMOBILE:

[1,063.]—I have a two-cylinder horizontal 5 by 6 engine in my automobile, which will fire three or four times after running awhile when the switch is cut out with the throttle partly open. These cylinders are water-jacketed on the sides only; the heads of the cylinders are not water-jacketed. Please answer in your columns whether or not it would remedy this trouble by putting on copper water-jackets on the heads of these cylinders. It is not on account of carbon in the cylinders that it fires without the spark, for it will do it after cleaning out the carbon.

New Castle, Pa.

FRANCES CORNETTE.

As many of the old-time motors with unjacketed cylinder heads have seen years of service, it appears to be jumping at conclusions to decide that the fact that this part of the motor is not water-cooled, is entirely responsible for the trouble. How about the performance of the motor when you first got it? Did it not run without overheating then? Naturally it is much more difficult to prevent a motor of this type from overheating, but if the engine has ever performed satisfactorily for any length of time it would seem that the latter, and not the design, was responsible. Placing copper water-jackets on the heads might prevent firing from pre-ignition through overheating, but it would not remedy the cause of the latter. See if some one or more of the numerous reasons that bring about this state, such as an overrich mixture, improper timing, poor cooling-water circulation, or the like, are not in evidence. Such a motor has to be kept in better condition to prevent overheating than one in which the efficiency of the cooling system is so high as to overcome these irregularities. It would be preferable to remedy the trouble first, even if the copper water-jackets were added.

### THE FUNCTION OF THE TREMBLER.

Editor THE AUTOMOBILE:

[1,064.]—In various books and articles on the subject of automobiles, it is stated that the function of the trembler, or vibrator, commonly used in connection with the coil of a high tension ignition system, is that of producing a rapid succession of discharges of electricity across the terminals of the spark plug during the moment of contact. Now a fellow driver tells me that there is nothing to this but theory, and that the trembler makes only a single spark, he says, due to the rapid succession of power strokes within the cylinder. I contend that this is not the case, else why does the vibrator make the same buzz at all engine speeds, and I

am getting sure I am right, but for the sake of having some documentary evidence on the subject, I would appreciate seeing your opinion published in "Letters Interesting and Instructive."

Paducah, Ky.

CHRIS. OLDHAM.

Your friend is partly right and partly wrong. The function of the trembler is not to produce a rapid succession of sparks at the plug during the ignition contact for a single stroke, but it does, of course, make more than a single vibration during the moments of commutator contact. The fact that the vibrator will continue to act indefinitely when the circuit is closed and while the current lasts is proof enough of this. The "rapid succession of sparks" theory, however, is pretty generally conceded to reduce itself to this: No trembler blade, as ordinarily made, and under ordinary conditions, can be made to work much faster than 200 vibrations a second and 1/200 second is time enough for the piston to move so far—at all but the very lowest speeds—that the second spark cannot be of much use if the first fail to produce ignition. For instance, sparks occurring 1/200 second apart are 18° apart on the crank circle at 600 revolutions a minute, and proportionately farther on closer at higher or lower speeds. Moreover, the speed of vibration as realized in actual practice, especially with run-down batteries or poor adjustment, is apt to be very much slower than 200 a second.

### ABOUT THE USE OF OXYGEN ON RACING CARS.

Editor THE AUTOMOBILE:

[1,065.]—In one of the late numbers of one of your contemporaries, I noticed an article on the use of oxygen for spurts in racing, in which they seemed to have no ill effect upon the motor; however, I have often heard that it quickly wears out the connecting rods and wrist pin, owing to the increased force of the explosion. Which of these is right?

Boston, Mass.

INTERESTED SUBSCRIBER.

It must be borne in mind that, in racing, the life of the car is a factor that is never taken into consideration. It is built to attain the greatest speed of which it is possibly capable and the fact that its life may be exceedingly short is never taken into consideration. Hence the ultimate effect of expedients which will aid it in fulfilling its mission do not enter into the question at all. They will make it run faster and that is all that is wanted. In skilled hands, oxygen can doubtless be employed to great advantage without seriously shortening the life of the motor, but that "it seemed to have no ill effect on the motor" is hardly conclusive. This simply means that it did not ruin the motor then and there, though this was one of the risks incurred by its employment. Increasing the force of the explosion considerably beyond that for which the motor was designed can only have one effect, and that is to wear it out sooner, if it does not end its career suddenly.

### CONCERNING HORSEPOWER AND LUBRICATION.

Editor THE AUTOMOBILE:

[1,066.]—Give horsepower of my R. E. O. 1907 car double cylinder, 4 3-4 bore, 6-inch stroke. Also please tell me the best make of oil to use on same machine. Have been using Vacuum mobiloil, but if there is anything better, I want it. How about Havoline oil? Have a letter from that company giving it a very good recommendation.

Angola, Ind.

HARLEY H. WEBB.

The indicated horsepower of the two-cylinder horizontal opposed motor of the Reo car is 18, at a speed of 1,000 r.p.m. That is, this is its output based upon its dimensions. We have no doubt it does as well as this on a brake test, if not better. The oils you mention both have an excellent reputation in the market and are very largely employed. Write to the makers of the car and ascertain which particular brand they recommend, as manufacturers frequently specify certain oils which they know from experience will give good service in their engines.

### SOME QUERIES ON VARIOUS TOPICS.

Editor THE AUTOMOBILE:

[1,067.]—Being a subscriber to your valuable paper, I desire to ask you some questions through your columns. Tire chains, I

believe, absorb more power than the leather type of studded anti-skids, but you can inform me if the Midgley tire treads would take as much power to operate as a regular rubber shoe which is smooth. Can you think of any engine with a two-cylinder vertical engine and sliding gear transmission with shaft drive? Either two- or four-cycle? What metal would you recommend for the engine bearings of a 1904 Franklin? Would babbitt answer?

New York City.

FRANK ALDEN MILLER.

While we have no data at hand, nor are we certain that there is any extant, we should say that on a smooth road tires with Midgley treads would consume slightly more power than smooth treads owing to the coefficient of friction being higher. But for the same reason, under adverse conditions, the wired tread would probably *waste* less power through slipping than would a smooth tread, as on a greasy or slippery surface.

The Renault small cars answer this description, and there may be one or two others, though we do not recall them at the moment. This car is made in France, and the engine is of the four-cycle, water-cooled type using thermo-syphon circulation. Babbitt metal would doubtless answer for relining the bearings of the car you mention, though the makers may have some special alloy which is superior, and which they would be pleased to supply on request.

### OIL FOR USE IN A COOLING SYSTEM.

Editor THE AUTOMOBILE:

[1,068.]—I would like to inquire whether or not the common kerosene or lamp oil can be safely used in the cooling system of a Reo two-cylinder car. I know of a number of parties who are using oil in the cooling system during the winter weather, and as it does not freeze, I would like to try it if practicable.

East Liverpool, O.

WALTER B. HILL.

Common kerosene oil would be far from suitable to employ as a cooling agent in the radiator of a car, as a moment's reflection should show. Even the best grade of lamp oil only has a flash point of 150 degrees Fahrenheit, what is usually known as "150 test oil." As the temperature of the cooling water of a car is more frequently above this point than below, when it is in use, it must be evident that kerosene would be rather a dangerous thing to have around under such circumstances. Ordinarily, a lighted match dropped into kerosene would be extinguished, but at this temperature and above it the result would be a blaze, the seriousness of which would be aggravated by the vapor arising from the kerosene when thus heated. We do not know exactly the grade of oil employed by manufacturers of oil-cooled gasoline engines, but presume it is a good grade of machine oil, of light body and high flash point. Another disadvantage of kerosene is that of its low boiling point, which would cause it to boil away very rapidly, even though the motor ran without overheating.

### WHAT IS WRONG WITH THE THREE-CYLINDER?

Editor THE AUTOMOBILE:

[1,069.]—Will you kindly advise as to whether, in your opinion, a three-cylinder, two-cycle engine is an undesirable proposition? A friend of mine tells me that three-cylinder engines have always proven failures. I would like to know the objections to such, if you would be kind enough to state them.

Will you also advise as to whether, in your opinion, it is detrimental to make a practice of running on the street car tracks on city pavements?

C. C. BLANCHARD.

Providence, R. I.

As the two-cycle engine fires every cylinder on every downward stroke of the pistons, a three-cylinder, two-cycle engine with the crankpins set at 120 degrees, makes a well-balanced and very smooth-running engine. We have never heard of such engines being failures. Doubtless your friend refers to the four-cycle type, in which a better balance is obtained with four cylinders than with three. The practice of constantly running on street car tracks concentrates wear on the tires at their weakest point—the sides of the tread—and this naturally tends to shorten their period of service, as tire makers will testify.

### WHAT FRICTION TRANSMISSION IS THIS?

Editor THE AUTOMOBILE:

[1,070.]—Some time ago I read an article in "The Automobile" descriptive of a new friction drive which has been put on one of the 1908 cars. I would like, if possible, to get a copy of this description and would be pleased if you would let me know how I can obtain the same.

CHARLES CHIPMAN.

Easton, Pa.

In the issue of THE AUTOMOBILE of May 9, 1907, there was published, on page 788, a description of the Gearless transmission, which is practically a planetary change-speed gear, utilizing friction members instead of the customary spur gears. This was the only special reference to a friction gear that represented any radical departure from standard practice in this respect.

### SUPPLEMENTING MR. POWELL ON IGNITION.

Editor THE AUTOMOBILE:

[1,071.]—The letter of E. Leeds Powell, No. 1052, in your December 26 issue, raises the question whether it is in the end more expedient to meet the principal objection to the dry battery as a source of ignition current by providing a larger source of supply, or by using the current more economically. Mr. Powell says very correctly that to ignite the mixture requires a hardly measurable amount of energy, the obvious reason being that only one spark is required to do the work if the mixture is anywhere near correct. Consequently, if the demand on the battery were limited to furnishing this one spark for each ignition, the battery ought to last long enough to satisfy the most exacting. The only reason for using a storage battery is to furnish cheaply a large supply of current to be wasted in unnecessary sparks, and the storage battery performs this service fairly well when it is in order, the worst objection to it being that the average inexperienced owner never knows whether his storage battery is in order or not, until it is down and out. If there were no current wasted, there would be hardly any reason for using the storage battery.

The makers of magnetos are attacking the problem from the standpoint of furnishing more current than is necessary, in order to be sure to have enough, and most magnetos absorb far more mechanical energy than is converted into electricity, so that mechanical wear and tear is the natural result. If a magneto could be built to furnish just current enough, and furnish it efficiently, it would be ideal; but the current depends on the speed, and to be sure of having current enough at low speeds, the magneto must be large enough to furnish a great excess of current at ordinary to high speeds, and all this is wasted. There is certainly need somewhere of a better ignition system than those in common use.

New York City.

HERBERT L. TOWLE.

### AN EXPLANATION OF DR. TUTTLE'S TROUBLE.

Editor THE AUTOMOBILE:

[1,072.]—While reading your valuable paper, "The Automobile," I noticed one of your reader's difficulties, that of Dr. Edward G. Tuttle, letter No. 1,028. I have had the same experience which he describes while repairing and putting into commission a motor boat this last June. The particles which he refers to are of shell-like substance and come, as he says, from the tank. This tank which I refer to was made of galvanized iron and is called charcoal iron, a good many tinsmiths making their tanks from this charcoal iron. This charcoal iron has a peculiar scale which gasoline in time will eat and it then floats around in the tank in small scale-like particles. I had this same experience happen on an automobile which I was repairing, these same particles clogging up the intake pipe and making the motor skip and miss as if there were short-circuited plugs on the engine. The remedy I used was to get a tinsmith to make heavy-gauge copper tanks for them. Of course, the cost of the copper tanks was about double the galvanized iron tanks, but the boat and the auto have been running since they were put in without any trouble to their owners.

Salem, Mass.

C. E. G.

### WANTS GOOD TOURING MATERIAL PRINTED.

Editor THE AUTOMOBILE:

[1,073.]—I read with pleasure your "1,000 Miles in New England," and in a later publication of "The Automobile" I read George A. Fay's letter about it, which you headed: "What One Autoist Wants to Have Printed." I wish to say that as far as I can learn a great proportion of American autoists are interested in articles like the above named, at least a great proportion of the autoists in this locality are, as I have heard quite a number discuss it since the trip has been published.

GEORGE H. WALTERS.

East Orange, N. J.



**COMBINED SPARK PLUG AND PETCOCK.\***

"Still another spark plug, you say! When shall we see the end of the stream of accessories of that type that are always making their appearance; always the same, and which are presented to us in as many different forms as there are dress-makers in France?"

"Quite so, yet another spark plug. But, then, what a spark plug! Its inventor, in creating it, certainly made no pretensions to bringing forth something superior, where the ignition itself is concerned, than that which already exists in the highest forms. If that had been his object he could not have produced anything better than the best plugs, and these are already legion.

"But in observing the new Eyquem plug you will note at a glance the incomparable advantages that it presents over others—advantages so striking that you will be unable to resist the desire to give it a trial, and we may note in passing (a fact that is of considerable bearing on the matter) that it is no more expensive than a good, self-respecting plug of any kind. Its

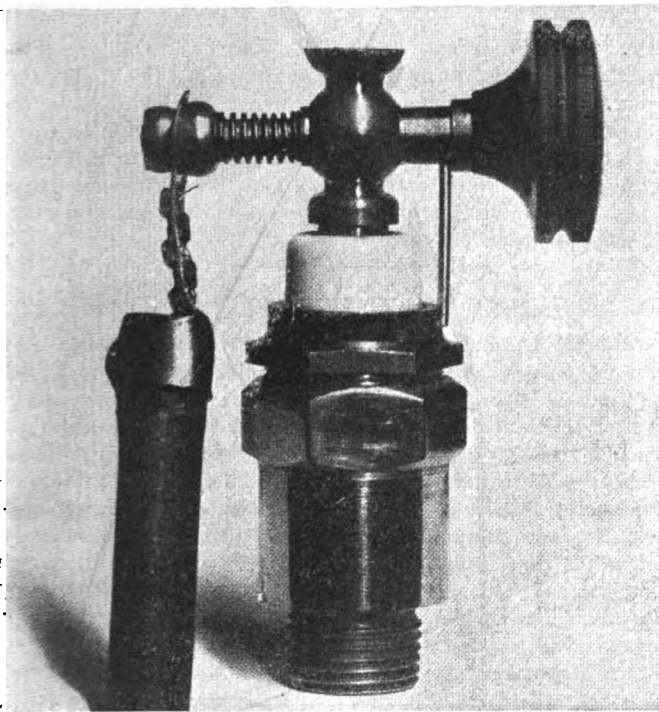

EYQUEM COMBINED PLUG AND PETCOCK SHOWING CONNECTION.

chief advantage is to be found in the fact that it may be cleaned automatically by the fresh gas in the cylinder. The button shown at the right in the illustration forms the handle of a petcock, and the body of the plug being pierced from end to end, the gas can blow through it when the handle is turned to the position shown in the photograph, thus cleaning it out very effectively.

"But that idea is not novel and its introduction has not been attended with the great success which was confidently anticipated for it, as the burning gases in passing through the porcelain insulation always endangered the latter. Where, then, is the invention of M. Eyquem?"

"It is to be found in the small piece of wire which will be noticed sticking down from the metal shank of the moving part of the petcock, and which, as shown in the illustration, comes in contact with the body of the plug when the petcock is open. In this manner the current is short-circuited at that plug the moment the petcock opens, so that the gas which is forced out of it is fresh and charged with gasoline. In consequence there is no danger of breaking the porcelain, for the reason that everything is cooled off and the cleaning is perfect. Here is an advantage of the new plug that will be appreciated by chauffeurs.

\*Translation from *L'Automobile*, Paris, by Charles B. Hayward.

Instead of having to dismount the plug to ascertain its condition, it is only necessary to open the petcock to a point where the wire extension comes within about a millimeter of the body of the plug. If the spark jumps it shows that the plug is all right and that the trouble must be looked for elsewhere. If it fails to pass, there is something wrong with the plug and it should be changed. It also provides an easy manner of hunting for a troublesome miss, as the current may be short-circuited on the plugs successively and by opening all the motor may be left so that it cannot be started. It also serves as a priming cup.

**ON BALL-BEARING GASOLINE MOTORS.**

My objections are based on the terrible jobs that we have with ball bearings on nearly every make of car, says David J. Smith in the *English Mechanic*. Ball bearings should not be placed in positions where they are subjected to shock. As soon as a little wear has taken place (ball bearings do wear, in spite of statements to the contrary), a slight hammer action is set up. In time, this either chips the hardened faces of cup or balls, or produces a slight flat on the balls. As soon as this occurs, the end of that bearing is near, and in a short time those balls resemble pieces of lump sugar in shape. No makers in the first rank are, to my knowledge, using ball bearings in their engines. When the internal combustion engine can be got to run as smoothly (not by multiplying the cylinders) as a steam engine, then it might be possible to use ball bearings satisfactorily, but not while the impulse remains as a violent shock on piston, as all explosions must be. Ball bearings are being used too freely at present by men who do not understand their actions and limits of successful application. Ball bearings are decided upon in a certain vehicle. Good! The makers' list of ball bearings is taken, and a bearing or bearings to take the load chosen ordered and fitted. Then the trouble starts, and the poor repairer has to take the blame of an idiotic designer, who ought to be dosed with the balls for pills. One make of car that I get a good number of to repair has ball cups and races forced into aluminum castings. When these are worn, it is almost impossible to get them out, grinding through the race with a small high-speed emery wheel being about the only way. This means a new race, balls, a lot of work, and a big bill. In cars built a few years ago, the chassis hardly ever gave trouble. In modern cars of many makers, not only has the machinery to be looked to, but new balls, races and bearings have to be fitted to hubs of wheels, axle bearings, bevel pinion shaft, etc. A favorite type of bearing now is the cage type, containing a single row of balls. Go to Olympia show and I will wager that you will find a great number of cars there with these fitted to the front wheel spindles. There are generally two of these bearings in each hub. Now, the steering wheels are inclined outwards, as they should be, which means that a big thrust is thrown on the under side of these bearings continuously, and I believe that not in a single instance is a *thrust* bearing fitted. The race is cut away on under side, and steering quickly gets sloppy, and no adjustment is possible. I have many modern cars that in six months' running have more slop in front wheels than in many old Panhards, Daimlers, etc., that have been running six years, and the slop on these is adjustable even then. Ball bearings are capable of doing the work, and the fault does not lie with this type of bearing, but the way that they are used. Here, again, I take the opportunity of stating that no man should inflict the design of a car on the public until he has served a year or two in a repair shop where all makes of cars are repaired. Here is a last instance of how balls are used. Rear axle of "Ruinem" car, live; wheels running on tubes driven by dogs from shaft. Plain ball ring bearings, two in each hub. No thrust bearing. Near side rear wheel worked in until internal hand brake shoes cut through supporting flange of drum, when brakes were on descending steep hill. Car swerved into ditch, nearly killing occupants, and ruining car. Age of car, nine months.

## HOW THE AUTOMOBILE IS WINNING THE BOUNDLESS WEST

A WAY out in the edge of Colorado is one real estate firm that uses six touring cars daily showing land to customers, and this has become a common thing for the real estate dealers of the West, so much more ground can they cover in this way, says the December *World To-day*. In the Panhandle of Texas, to which excursions are being run every month, every firm uses cars. In one place a firm has the sale of ranch lands twenty-two miles from the railway station. To get a good track it plowed a sixteen-inch furrow as straight as could be drawn, turning over the sod and leaving a smooth, hard surface. Then a car was run over this route, with one wheel in the furrow and the other whitened with flour, leaving a mark on the sod. Another furrow was turned, and now there is a straightaway course of twenty-two miles with two smooth, hard tracks, and the cars with seven passengers make the trip in forty-five minutes several times a day.

No one in the Western town gets so much practical good out of a car as the physicians. Distances are magnificent on the plains, and while settlement has advanced, the towns are far apart, compared with the East. The county-seat doctors have a clientage that reaches out twenty miles in every direction, and with teams and buggies they find it almost impossible to cover it. With a runabout they make their seventy-five to one hundred miles a day, and are satisfied. Those who do not own cars pay more than the cost of maintenance in hiring them from liverymen. The automobile has done more for the physician's practice than anything the West has ever discovered.

The editor of a country paper in the West wrote four columns describing "Our New Auto," after he had purchased a machine. It was not necessary. Out of his two thousand subscribers probably one-tenth knew more about motor cars than he did himself; one-twentieth owned cars, and as many more will by next spring. Twenty-two cars were photographed on the streets of a prairie town one day last summer, and ten more owned in town were absent. Trips to the mill with a few odd sacks of wheat, or to market with the fresh vegetables are ways in which the Western farmers are utilizing their cars. It is becoming a possession as common in the Western country town as it is in the Eastern city.

The problem of the car in the country town is entirely different from that of the city owner. Wages are not so high and the conditions inspire a greater self-reliance on the part of autoists. Take a specific instance of a town two hundred miles west of the Missouri river in central Kansas. It is a typical prairie city of less than five thousand persons. The automobile was intro-

duced at first by several poor second-hand machines, and only two years ago did the first standard machine make its appearance. Now there are twenty cars, one-fourth of them touring cars, the remainder runabouts. Others are being added every month. Many farmers are buying, several mail carriers have runabouts with which to cover their rural routes, and a livery with automobiles for hire does a good business.

Western roads, in the prairie States especially, are very fine eight months of the year. They are free from stones generally, and hills are moderate, all tending to encourage the motorist. It is because of these conditions that it is becoming possible for the man with moderate means to own a car. There is so little amusement in the plains region—the mountains and the lakes are nearly a thousand miles away—and motoring opens up a wide new field for pleasure. When one may drive thirty to fifty miles in an evening over dirt roads that are as smooth as asphalt, with prairie breezes blowing health and rest into one's cheeks, it is worth while. On such roads tire troubles are reduced to a minimum. My first two thousand miles with a four-cylinder car were without a puncture, and with no injury except a sand blister on one tire. Tire records of four thousand to six thousand miles are common, and there is much satisfaction in the promise of long life for the most sensitive portions of the equipment.

### AN IMPROVED COLLAPSIBLE AUTO PAIL.

Automobilists having traveled any distance with a leaky radiator which had to be filled with the ordinary type of collapsible canvas pail have generally arrived home with stronger feeling against the latter article than against their cooling apparatus. Though it is easy to bring the water to the radiator it is not such an easy matter to put the liquid where it is wanted. An improved type which has recently been put on the market overcomes these difficulties by making the pail funnel shaped and fitting the base of it with a metal tube ordinarily closed by a simple valve. The pail, the simplicity of which is apparent by the illustration, is made of rubber cloth, bound by a circle at the top, to which is attached a handle, the valve being operated by means of a chain fastened to the handle.

**Cheap taxicab service** was established in London on New Year's Day. Twelve cents a mile, or 12 minutes, and 6 cents the half-mile, or 6 minutes, is the new rate.



HOW TWO REO CARS WERE UTILIZED BY E. C. SPERRY AND PARTY FOR A DAY'S DUCK HUNTING AT RATON, NEW MEXICO.

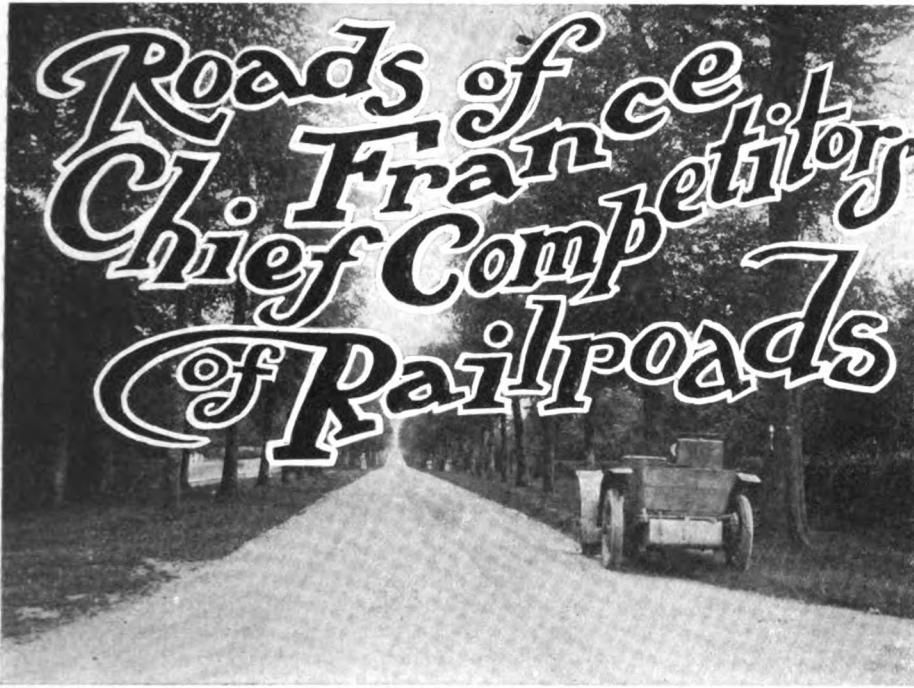

ONE OF THE STRAIGHT, BROAD HIGHWAYS THAT MAKE FRANCE ENVIED AMONG NATIONS.

THE present road system of France was started by the first Napoleon. No new roads of importance have been opened in some years, but the work of the engineers in the Department of Public Works of France is confined to keeping the roads in a state of high efficiency. France, to its remote and inaccessible sections, is so traversed with excellent roadways that there is now no necessity of adding many more lines of communication. The highways are the chief competitors of the railroads. The far reaching and splendidly maintained road system has distinctly favored the small landed proprietors and in their prosperity and their ensuing distribution of wealth lies the key to the secret of the wonderful financial vitality and solid prosperity

highways, their national system consists of 23,656 miles of national routes, which cost the nation \$303,975,000 to build. The national routes traverse the entire nation and connect the important centers, and are now paralleled by railroads. They have also department routes connecting the important centers of a single department, also their more local roads. The national roads, 23,656 miles, are in charge of a single-headed department, with one man responsible for their maintenance and good condition.

Public opinion requires that the local highways be kept in a sufficiently good condition to permit of a good draft horse hauling a load of 3,306 pounds eighteen and a half miles per day.

#### PRIZE GIVING FOR ROADS MAINTENANCE.

OCONOMOWOC, Wis., Dec. 30.—There is now a plan on foot to offer a number of handsome prizes for good roads building, commencing early next year, the object being to greatly improve and to maintain one of the most important runs in the State. Back of the movement is the Milwaukee Automobile Club. The project is to divide the highway into several districts and to offer cash prizes for the best kept sections. The prizes will be offered to the several property owners or farmers through whose premises the highway runs. The highest prize will be \$250, and they will run down to a sum that will be large enough to stir up interest alone.

This section of the State is the most famous in all Badgerdom in the matter of unique schemes to improve and keep up the roads. At one time the wealthy summer home owners offered school children cash prizes for throwing stones off the road while they were trudging back and forth in attending schools in country districts. Pathmasters were appointed, they watched the work, and on their reports the prizes were awarded.

It might be mentioned in this connection that not long since the women's clubs of Kane county, Ill., raised over \$1,000 to improve and beautify a road along the Fox river. The money was raised by selling a silver spoon, engraved in the bowl of which was the head of a famous Indian chief who used to trail over the road in pioneer times and always was noted for his kindly treatment of the palefaces. The spoons have been sold to people living in half the States of the Union

#### INDIANA SPENT \$7,000,000 FOR ROADS IN 1907.

INDIANAPOLIS, IND., Dec. 30.—Indiana has spent almost \$7,000,000 for new roads during 1907, and the most of this amount since April. This is greatly in excess of the amount spent for similar purposes in any previous year and is due largely to the law passed by the Indiana Legislature last spring authorizing roads not more than three miles long, when petitioned for by fifty taxpayers of a county, providing it connected two roads traveled by rural mail carriers.

The resources for road making consisting of rich gravel and limestone deposits in almost all parts of the State, together with the coming of the bicycle, the automobile and the rural route carrier, has done more than anything else for roadmaking. Some counties have built from sixty to one hundred miles of new gravel or stone roads during the present year and figures will soon be issued by the State on the subject.

It is estimated that more than 35 per cent. of Indiana roads are now improved, probably a greater average than any other Western or Middle West State can boast. Although the new road law has not been greatly in favor with public officials, there has been no determined effort so far to test it. In Madison county, where the greatest objection is raised to it, a number of new contracts have recently been let.

Indiana possesses some of the best established automobile manufacturing concerns in the entire country, and the increasing number of autos undoubtedly has had a vast influence upon the great progress in roads building in the year just closing.



Vol. XVIII Thursday, January 2, 1908 No. 1

THE CLASS JOURNAL COMPANY

Flatiron Building, Madison Square New York City

H. M. SWETLAND, President

EDITORIAL DEPARTMENT

A. G. BATCHELDER, Managing Editor R. F. KELSEY, Associate Editor C. B. HAYWARD, Engineering Editor W. F. BRADLEY

BUSINESS DEPARTMENT:

A. B. SWETLAND, Business Manager LOUIS R. SMITH FRANK B. BARNETT W. I. RALPH, 1035 Old South Building, Boston, Mass. H. GURNETT, H. E. WESTERDALE, 836 Monadnock Block, Chicago, Ill.

Cable Address - - - - - Autoland, New York Long Distance Telephone - - - - - 300 Gramercy, New York

SUBSCRIPTION RATES:

United States and Mexico - - - - - One Year, \$3.00 Other Countries in Postal Union, including Canada - - - - - One Year, 5.00 To Subscribers—Do not send money by ordinary mail. Remit by Draft, Post-Office or Express Money Order, or Register your letter.

FOREIGN SUBSCRIPTION AGENTS:

ENGLAND:—Illiffe & Sons, Limited, 20 Tudor Street, London, E. C. FRANCE:—Boyveau & Chevillet, 22 Rue de la Banque, Paris. GERMANY:—A. Seydel Mohrenstrasse 9, Berlin.

Copyright, 1907, by The Class Journal Company. Entered at New York, N. Y., as second-class matter.

The Automobile is a consolidation of The Automobile (monthly) and the Motor Review (weekly), May, 1902, Dealer and Repairman (monthly), October, 1903, and the Automobile Magazine (monthly), July, 1907.

Table with 2 columns: Year and Copies printed. Rows for 1905 (730,000), 1906 (791,000), and 1907 (888,900).

Importers Make Bold and Most Artistic Front.

Even those who are surcharged with American automobile patriotism must admit that the Importers have made a brave attempt this week in Madison Square Garden to challenge the general belief that the day of the European car in this country is waning and approaching the last quarter of the moon.

This situation was inevitable from the beginning, but the reaching of it may have come much sooner than was anticipated by those dealing in foreign cars. Of these concerns the most discerning have grabbed time by the forelock and secured an additional agency for a home product.

What Has Been Attained with Free Alcohol.

Much surprise seems to have come to certain observers of the fuel situation that immediately upon the passage of free alcohol legislation in this country a tremendous industry did not spring up and the price of the commodity fall to a purely nominal figure.

So much for what has been accomplished in the space of a single twelve-month toward lowering the price within approach of an attainable minimum. Where its use as a fuel is concerned, it was no more to be expected that this would meet with any immediate widespread adoption than that millions of capital would at once be invested in its manufacture.



The Great Value of Uniform Auto Legislation.

At a time when the legislative mills are about to take up the task of grinding out a new crop of automobile legislation, it is opportune to call attention to one or two salient points in the legal situation, which every autoist who has his own interests and that of his confrères at heart should bear in mind.

The most immediate remedy is that of uniform State laws, and every autoist in the country should do his best to second the able efforts of the American Automobile Association in this direction.

Of course, the Federal registration bill of the A. A. A. introduced at Washington refers solely to registration, and when passed will establish a plan whereby home registrations will permit an autoist to go anywhere in the country.

## OVER FIFTY STARTERS EXPECTED FOR THE GRAND PRIX

PARIS, Dec. 23.—Fifty-five to sixty is estimated to be the number of cars which will line up for the start in the French Grand Prix, to be held under international rules, during the first fortnight of July. Entries only opened a few days ago, and will not close until 6 p.m. on February 15, but sufficient is known of the intentions of all the important constructors of automobiles to prophesy with certainty a larger entry than for any event in France since Paris-Madrid.

Excluding America, whose participation is very doubtful, five nations will take part in the great speed test. France will supply full teams from Renault, with Szisz, Caillois and Dimitri as drivers; Panhard, to be handled by Heath, probably Teste, and a third not yet chosen; Brasier has definitely made up his team with Théry, Baras, and Bablot; Bayard-Clément, though not having signed any contracts, will certainly have Garcet as leader, and probably Rigal and Leblon; Dietrich, as in previous years, will have the same trio, Duray, Rougier, and Gabriel; Motobloc has only chosen two drivers, Pierron and Courtade, the third to be appointed in January; C. G. V. will have either one or two cars at the starting line, but nothing is known as to their drivers; Breguet has promised two six-cylinders, but as the exact regulation for this type of engine has not yet been made known, no steps have been taken; Mors is not absolutely certain to start, though should they do so, Gasté and Landon will be two of the drivers. Hotchkiss will not race; Gobron and Porthos are doubtful. If rumor can be relied upon, Westinghouse will participate in a race for the first time. For France, this would give 22 certain starters and 9 doubtful.

Italy will have four full teams. Fiat drivers will be Nazarro, Lancia, and Wagner. Itala will be handled by Cagno, Fabry, and probably Henry Fournier. Isotta-Fraschini is expected

to have as drivers Minoia, Trucco, and Tamagni. S. P. A. is said to be busy on three cars, but has not chosen drivers.

Belgium has already entered three Germain cars, to be driven by Degrais, Roch-Brault, and Perpère. Pipe has at present only selected Hautvast, but two other drivers are being looked for. Minerva refuses to make an official announcement, but probabilities are that three cars will be entered.

From Germany, Mercedes, Benz, and Opel are certain starters, Mercedes to have as drivers Willy Poegge, Salzer, and Baron de Caters, or Burton. Hemery, Hanriot, and Erle will handle the Benz cars. Fritz Opel and Jaerens will drive for Opel.

From England Ariel is the only certain starter, one car from this factory being finished, and will probably be joined by a second. Crossly and Simplex are spoken of as intending to race, and the same is said of Napier, but this latter firm may be set aside as a non-starter.

On a moderate estimate this would give 53 starters, made up of 22 French, 12 Italian, 9 Belgian, 8 German, 2 English.

According to the information to be picked up around the factories, it would appear that all the contestants in the 1908 Grand Prix will have the maximum bore of 155 millimeters and stroke from 170 to 175 millimeters. At the Panhard factory three engines have been built and tested out on the bench, the cylinder dimensions of each being 155 by 175 bore and stroke. Before going on the cars they will be put into motor boats and tested at Monaco. Shaft drive will be adopted on this year's Panhard racers, and there will be four speeds and reverse, with ignition by high-tension magneto.

Bayard-Clément has built three distinct models with cylinder dimensions respectively of 155 by 160, 155 by 175, and 155 by 185 bore and stroke, all being well advanced except the last. The probability is that the 155 by 175 engine will be adopted.

## A. A. A. RACING BOARD ISSUES SANCTIONS AND ADOPTS RULES

SANCTIONS for three important contests were decided upon by the executive committee of the A. A. A. Racing Board, at a session held at 437 Fifth Avenue, New York City, Saturday morning, December 28. At the session were Vice-chairman Frank G. Webb, who presided in the absence of Chairman Thompson; Dave H. Morris, A. R. Pardington, E. Lincoln Lippitt, A. G. Batchelder, A. L. Riker, and Secretary F. H. Elliott. President William H. Hotchkiss was also present.

The sanctions granted were as follows:

Automobile Club of America, Ormond-Daytona, Fla., March 2-7.  
Savannah Automobile Club, Savannah, Ga., week beginning March 15.

Robert L. Morrell, Chairman, Briarcliff Trophy Race, Westchester County, N. Y., April 24.

It being the sense of the meeting that in future sanctions the use of international and national should be granted only with the consent of the Board, on motion of Mr. Morris, seconded by Mr. Lippitt, the following was adopted to be incorporated in the racing rules:

An international race is a race where the entrants are respectively named by and represented by two or more of the recognized national affiliated automobile clubs of the world.

A national race is a race where the entrants are respectively named by and represent any two or more of the automobile clubs affiliated with the American Automobile Association.

It was stated that the compilation of the 1908 racing rules was practically completed and same will be announced in printed form early in the new year.

### CHAIRMAN OF CUP COMMISSION MARRIES.

Jefferson deMont Thompson, chairman of the A. A. A. Racing Board and of the Vanderbilt Cup Commission, and Mrs. John E. Dunlap-Bradshaw, daughter of the late Robert Dunlap, were married Saturday noon, December 28, at the home of the bride's mother, Mrs. Robert Dunlap, 111 West Seventy-second street, New York City. The Rev. Dr. Allen McCreedy, of the Rutgers Presbyterian Church, performed the ceremony. The bride's uncle, H. K. Burras, gave her away. Mrs. J. Lawson Johnson, of London, the bride's sister, was matron of honor. The maid of honor was Miss Marion Baker. P. S. Thompson was his brother's best man.

### S. A. E. MEETING AT THE NEW GRAND.

Friday afternoon and evening, January 3, there will be held at the New Grand Hotel, Broadway and Thirty-first street, New York, the third annual meeting of the Society of Automobile Engineers. The afternoon session will be devoted to the election of officers and the reading of papers on various subjects of interest. This will be followed by a dinner in the evening and the reading of the remaining papers prepared for the occasion. Among the subjects to be discussed are the following: Automobile Hub Ball Bearings, by Henry Hess; Nature Hard Gears, by Thomas J. Fay, and Some Notes on Self-aligning Taper Roller Bearings, by H. W. Alden.



## JERSEYMAN'S ECONOMICAL FIGURES FOR 6,000 MILES

Editor THE AUTOMOBILE:

A few days ago I read in THE AUTOMOBILE of a detailed statement of the items of the cost of upkeep of a 20 horsepower car. I send the following account of my expenses:

My car is a 24-horsepower, four-cylinder, four-cycle, air-cooled car, with the cylinders in a "V." It weighs, without the top, empty, over 2,200 pounds. It has storage battery and dry cells in reserve. It cost, without top, \$2,500 f. o. b. factory.

This car, between May 28, 1907 (date of purchase) and the end of November, 1907, was driven 6,006 miles by me. Of this mileage about 1,000 miles was on a trip through New England and the rest was made in New York and New Jersey and vicinity. While a large part of this was on macadam, much driving was done in out-of-the-way country districts on dirt roads.

I have kept two separate books for this car. In one book I enter each day (that I drive) the odometer reading on starting and on my return, and the amount of gasoline put into the tank. I also enter therein the amount of oil, grease, etc., put in and date of same, also the date when anything is done, such as taking off and greasing wheels, putting on or taking off tires, charging battery, etc. In the other book I enter every item and its cost, and the date when the amount was paid. In that way many of the items in the first book appear also in the second book, which, of course, contains all items of whatsoever nature they may be.

	Cost in cents, per car mile.	
Tires: Casings.....	\$101.05	1.682
Inner tube.....	9.40	0.156
Repairs to casings and tubes.....	18.55	0.308
Anti-skid devices.....	.....	.....
Power: Gasoline, 531 gals.....	94.45	1.572
Cyl. oil, 15 1-2 gals.....	11.90	0.198
Grease and gear case oil.....	3.30	0.054
Ignition: Charging storage battery.....	3.95	0.065
Dry batteries.....	3.30	0.054
Spark plugs.....	.....	.....
Repairs: Miscellaneous.....	.....	.....
Ordinary.....	.....	.....
Due to accidents.....	3.90	0.064
Lights: Carbide and kerosene.....	2.12	0.035
Garage clothing.....	1.00	0.016
Labor.....	11.05	0.182
Making adjustments.....	4.90	0.081
Spare parts taken on trip but never used....	3.05	0.052
Sundries.....	20.16	0.335
Replacing lost and damaged tools.....	.....	.....
	\$292.08	
Storage and cleaning.....	51.25	0.856
	\$343.33	5.716

In order to have a clear understanding of the above it will be necessary for me to make the following statements: (1) Under the item "labor" is understood work such as the follow-

ing: Taking off wheels and greasing their bearings, taking off tires, sandpapering and shellacking rims, replacing tires, washing and cleaning outside of engine and sub-frame, etc.; but no repairs of any kind were charged up under this head. (2) Under "adjustments" were charged once taking up wear in connecting rods and adjustment of level of carbureter. (3) The repairs due to accidents were: Straightening steering rod on account of running into a dog, and repairing a lamp damaged by a carriage being backed into it.

To make a fair comparison between the cost of maintenance of my car and the one mentioned in the issue of December 12 I shall have to say: That I only had to pay for storage (which included washing and cleaning the car) during the months of June and July, and on the two weeks' New England trip; the rest of the time I was able to store my car rent free in the garage of a relation. In order, therefore, to make the comparison a fair one, I shall add to the item of \$51.25 for storage and cleaning the sum of \$120, or a total of \$171.25, although I actually paid only \$51.25. That is to say, I assume that this year I paid for nine months of live storage (including cleaning) at \$15 and three months of dead storage at \$5, because I have not the time to use my car during the winter and consequently lay it up during that season. On this basis my expenses would amount to \$463.33, or \$0.07714 per car mile, for a mileage of 6,006 miles.

Five hundred and thirty-one gallons of gasoline for 6,006 miles gives an average of 11.10 miles to the gallon; 15 1-2 gallons of cylinder oil gives an average of 387.09 miles to the gallon.

Of the four tires originally on my car, one went 4,940, one 5,072, one 5,200, and the fourth 5,800 miles.

My valves were not ground until after the car had gone over 5,000 miles, and then they were not at all in bad condition. My spark plugs did not have to be cleaned until after I had gone over 5,360 miles, and I have the same plugs in the engine today that came with the car when I bought it.

I seldom carried less than four in my car, and often carried five. It is safe, therefore, to place my average number of passengers at three; three and a half would be nearer. On the basis of what I actually paid, therefore, it cost me 1.905 cents per person per mile, leaving out of consideration the first cost of the car. In the second case, where I assume that I paid \$463.33, I should have paid 2.571 cents per person per mile.

My car is in excellent condition in every respect, and, so far as my knowledge extends, I do not know of any car of its weight and power which has been run so economically and with such remarkable freedom from trouble of any kind, except some of the same make in this vicinity with whose owners I am acquainted.

The top, speedometer, insurance, vulcanizer, registry of car, 1907 license, and car number cost \$247.10.

J. G. C.  
EAST ORANGE, N. J.

## WHERE THE AUTOMOBILE REPLACED THE RAILROAD

WESTBURY, Long Island, N. Y., Dec. 30.—According to the New York Times correspondent more than two hundred large automobiles brought week-end parties to nearly all the large country places of Nassau County, as well as a number in Suffolk County, where the Christmas festivities will continue until after the new year is ushered in.

All the Long Island macadam roads were in fine shape for automobiling, and the colony entirely dispensed with railroads and went to the various country places in large motors. At

Hempstead, Cedarhurst, Woodmere, Great Neck, Garden City, Wheatley Hills, and the Piping Rock and Nassau Country Clubs there was not a large place but had its full quota of visitors.

Though there has been but little wintry weather thus far this season, Long Island roads do not suffer to any appreciable extent from heavy snows, so that cars are in constant use between country places and the city throughout the winter. This applies more particularly to the western end, or macadamized sections. The Jericho turnpike is now improved as far as the county line.

## THAT NEW YORK CITY ORDINANCE CONCERNING USE OF CHAINS

THROUGH the activity of Chairman Charles T. Terry, of the A. A. A. Legislative Board, representatives of city, state, and national automobile organizations protested to the Park Board of Greater New York at a hearing, held Thursday, December 26, against the recently enacted ordinance which forbids the use of chains on wheels of vehicles entering the park or driving on park thoroughfares anywhere in Greater New York. Believing that the acceptance of such an ordinance without a protest and test of its legality might bring about general adoption of similar measures in cities throughout the entire country, Chairman Terry called the automobilists together. A conference at A. A. A. headquarters, No. 437 Fifth avenue, preceded the hearing at the Arsenal in Central Park.

W. W. Niles and A. R. Shattuck represented the Automobile Club of America; Russell A. Field appeared for the Long Island Automobile Club; Melvin Bender spoke for the New York State Automobile Association, and, of course, Chairman Terry represented the national organization. Alexander Schwalbach appeared for the Good Roads Association of Brooklyn. The three Park Commissioners of Greater New York were all present, with Mr. Smith of Manhattan Borough presiding.

Before the protestants began, Commissioner Smith advised that the legal aspect of the matter was not to be discussed, as the ordinance had been framed by the Corporation Counsel. Mr. Bender, of the State Association, was the first speaker. He said that it was absurd to restrict any more than necessary the traffic of automobiles in the parks, which were primarily designed for pleasure purposes. The driveways were limited altogether to pleasure vehicles, and automobiles constituted today a large part of such vehicles.

Chains, he declared, were necessary in metropolitan districts, where the lives of pedestrians were imperiled if a machine were unable to come to a quick stop. The chains prevented skidding, that was otherwise inevitable in muddy or cold weather. If the park authorities forced them to comply with the regulations they must stand responsible for the consequences, he said.

He added that even New Jersey, regarded as the mother of automobile persecution, had no measures so drastic as the recent park ordinance. The use of chains on motor vehicles is prohibited on the parkways, but is allowed when the weather conditions make it dangerous both to the occupants of the automobile and those who use the driveways. Even the steel caulks on the horses' hoofs were more injurious to the roads than the smooth link chains which were universally used on tires.

In conclusion he questioned the authority of the board to make such a mandatory regulation. By the city charter they were empowered to regulate traffic, but that did not give them the power to restrict pleasure vehicles, he said.

Hiram Percy Maxim, of the Mechanical Branch of the Asso-

ciation of Licensed Automobile Manufacturers, next discussed the ordinance and gave his opinion of the injury that a road suffered by the use of chains on automobile wheels. He said that it was the only expedient that ten years of study of the problem brought forth. He told of his investigations made on an endurance run when he examined a macadamized road after a hundred machines had passed over it, every one of the automobiles bearing the chains. The road, he said, had sustained no damage. The soft bed of the road after stormy weather and the pneumatic cushion of the tire, according to his view, absorbs the chains, without inflicting any appreciable injury to the road.

Mr. Terry argued that the present roads were inadequate for modern traffic. In the evolution of locomotion, the roads have failed to keep pace. They are the same now as they were long before the discovery of the automobile. A new surface should be applied to the driveways, so that they would be able to sustain the strain of automobile traffic. The bad effect of the New York ordinance would travel to other cities, which patterned their regulations after the metropolis, he declared.

The popular impression that automobilists are superior to the law, declared Mr. Niles, had gained considerable ground, but it was entirely erroneous. They were more amenable to reasonable legislation than any other class of people, but in this instance he thought that their good nature had been violated. The enforcement of the new ordinance in the Bronx would be greatly felt, as the only roads worth traveling over in a motor car are those under the direction of the Park Department. To compel automobiles to go without chains on wheels would drive them to the other thoroughfares which were in bad condition.

For the preservation of the roads Mr. Shattuck suggested an emulsion composed of water, soft soap and oil. This formula is now being used with much success in Boston. Commissioner Smith said that the department had experimented with the emulsion, but the cold weather had forced postponement until another season of the year.

Mr. Field confirmed what the others had stated and added other convincing facts.

P. W. Strong was the final protestant, who asserted that smooth tires without chains did more damage to the roads than the chain-bearing wheels.

At the conclusion of the hearing, the Automobile Club of America offered to have tests to show the Board the effects of the tires upon the roads in various weather conditions. Commissioner Smith appreciated the offer and said the club would be called upon if the Board considered it advisable to have such tests.

Future developments will be awaited with much interest, for the automobilists do not intend to accept the ordinance without a further protest and possibly legal action.

### BUT THE AMENDMENT WAS VOTED DOWN.

PHILADELPHIA, Dec. 30.—Although in the present conditions of affairs in Philadelphia, the "gang" has things pretty much its own way, the reformers still have a few watchdogs in councils who keep tab on their confrères. The other day when an ordinance was introduced calling for an appropriation of \$5,000 for the purchase of an automobile for the use of the chief of the highway bureau, Councilman Lambirth created not a little consternation by proposing an amendment providing that the car should bear on both sides the words "The Department of Public Works." Such a proposition, it was objected, was insulting, and the amendment was accordingly voted down.

### TENDENCY FOR BUYING BECOMING APPARENT.

CLEVELAND, O., Dec. 30.—At this season of the year the demand for automobiles for immediate delivery is not as strong as in the Spring, the demand in most cases being for limousines and landaulets. During the past two weeks orders have been coming in rapidly to the offices of the Peerless Motor Car Company, which shows the tendency for heavier buying after the first of the year. The Peerless Company has kept a sufficient corps of men at work every day to supply the demand for their cars and within the past week have increased this force.

The new buildings commenced early in the fall are now ready for occupancy and the drafting room and office are in use.

## NEW YEAR FULL OF PROMISE FOR THE CLUBS

### HARRISBURG TO PHILADELPHIA, AND RETURN.

HARRISBURG, PA., Dec. 30.—The Motor Club of Harrisburg will hold its second annual endurance run May 4 and 5, and active steps are already under way for the big event. The contest committee has decided to make the 1908 tour to Philadelphia and return, with an increased mileage each day over last season's hard test. The route for the first day will lead through Lebanon, Reading, Kutztown, Allentown, and then on to Philadelphia, where the night control will be established. This course will be almost 150 miles. On the return trip the route will lead through Norristown, Pottstown, Reading, Lancaster, and to Harrisburg, a mileage of about 130 miles.

The rules which the committee are now considering will be much stricter than those for the initial contest. All bonnets and tool boxes will be sealed, and cars and engines will be required to be kept running at all times except when the rules of the roads or punctures require a stop. Penalties will be given for all gasoline, oil, and water taken on after the official start of each day, and after the run a technical committee will examine all cars for any material breaks or defects.

The rules and penalties will be made clear to all contestants through a table which will show the penalties in points which can be registered against any car. There will be four classes, viz.: Touring cars costing \$2,500 or over; touring cars costing less than \$2,500; runabouts costing \$2,000 or over, and runabouts costing less than \$2,000. In addition to the four trophies for the 1908 run the four touring cars which were tied for the 1907 trophy will contest for its permanent ownership. These cars are the White of W. C. White, the Pullman of E. G. Irvin, the Thomas of S. K. Hamburger, and the Pierce Arrow of H. F. Rawll.

### YORK (PA.) CLUB WANTS SOME RACING.

YORK, PA., Dec. 30.—Enthusied by the success of other racing meets held recently in this part of the Keystone State, members of the York Automobile Association are contemplating the holding of several big meets here next season. Officials of the York Motor Car Company, including H. R. Averill, sales manager, have announced that they are ready and willing to foster the auto racing sport here and it has been suggested that a mile track be placed in condition at the grounds of the York County Agricultural Society. The present half-mile track at the fair grounds is one of the best in the State for horse racing, and it is overlapped by a mile track. This is used at present for training purposes. Local auto enthusiasts are of the opinion that it would take little expense to place the mile track in good shape, including the banking and fencing of it. The plans of the Yorkers are that at least three race meets be held here each season. Mile tracks in this part of the country are more than a luxury and the York autoists propose to start the innovation in the early Spring.

### BAY STATERS HAVE A NEW YEAR'S TREE.

BOSTON, Dec. 31.—The annual meeting of the Bay State Automobile Association for the election of officers and the transaction of other business will be held at the clubhouse on Monday, January 6.

To-night, in accordance with a long-standing custom, the annual Christmas tree and New Year's celebration was held. The Christmas tree was arranged by the house committee and provided a large amount of amusement for the many members who were present. The gifts were selected with care by the committee and nobody present failed to receive a remembrance.

### MASSACHUSETTS MIGHT SUPPLY A CUP COURSE.

WORCESTER, MASS., Dec. 30.—The Worcester Automobile Club as usual will aid and abet the Massachusetts State Automobile Association in its legislative and other work this season financially and otherwise. At a meeting of the Board of Governors, Saturday night, it was voted that the club appropriate \$300 for the State association over and above the regular dues which are paid, in order to assist the State officers in the work of looking after the interests of the autoists of the State at the State house this winter.

In common with the rest of the clubs, Worcester club is insistent in its support of the "light bill" calling for lights on all classes of vehicles using the public highways at night, and the bill which was introduced last year giving to mayors and aldermen of cities and selectmen of towns the right to set apart sections of highways for automobile events the same as they can do now for horse, bicycle, and foot races, will be pushed again this year.

A smoker at which aeronautics will be the chief topic is planned for the club the latter part of January and a dance in the club hall is another event which is due about January 14.

Through tourists on the New York-Boston route between Worcester and Springfield will find the highway a hard one. George Stowe made the more than 100 miles to Springfield and back yesterday in his White steamer. "There's everything there to make bad riding," he said afterward. Mud, ruts, snow and ice are in the combination.

### BUFFALO'S CLUB PROSPEROUS AND HUSTLING.

BUFFALO, N. Y., Dec. 30.—According to the annual report of the treasurer at the recent annual meeting of the Automobile Club of Buffalo, that organization has \$3,357 in its treasury, \$2,500 of which has been deposited in the American Savings Bank as the nucleus of a country clubhouse fund. The present membership is rapidly approaching the 1,200 mark, and the newly elected president, Frank B. Hower, intends, with the cooperation of Secretary Dai H. Lewis, to make it the largest automobile club in the country before 1908 is concluded.

President William H. Hotchkiss, of the American Automobile Association, is the father of the local club, and in the course of his remarks at the annual meeting, which was attended by over 350 members, he complimented the club upon the size and character of the assemblage and said there was not another club in the United States which could gather so many members together on such an occasion. He exhorted the members to keep up the present spirit and to maintain a big and enthusiastic working club, democratic in character, where owner, driver, mechanic, agent and maker could meet and work for the general benefit.

The retiring president, Seymour P. White, was presented a silver loving cup, E. H. Butler, proprietor of the Buffalo *News*, being the spokesman. Charles Clifton and E. R. Thomas are on the club's board of governors, on which Mr. Butler also serves.

### A. C. OF TOLEDO ORGANIZES AND ELECTS.

TOLEDO, O., Dec. 30.—The Automobile Club of Toledo is now organized and an applicant for membership in the Ohio State Automobile Association. The club starts with 125 charter members, and these officers were selected for the ensuing year: President, E. D. Libbey; vice-president, E. J. Marshall; treasurer, J. M. Steenberg; secretary, George S. Mills. The board of governors chosen consists of the above officers and the following: Marshall Sheppey, W. W. Morrison, John Mockett, J. J. Manning and F. M. Brigham.

## BOSTON TRADE CHANGES FOR THE NEW YEAR

**B**OSTON, Jan. 1.—The New Year brought with it a number of changes in the local automobile trade and, though there are still some agencies of well-known cars to be placed, the trade in general is pretty well settled down for the coming season's business. One of the most interesting announcements comes from the Studebaker Automobile Company, of South Bend, whose product of gasoline and electric pleasure and commercial vehicles has been represented here for a number of years by agents. Early in the New Year this company will discontinue its agency and will open a branch house in the newer automobile section on Boylston street. The company also proposes to construct a fireproof garage with complete accommodations for gasoline and electric vehicles and with a fully equipped repair shop and a complete line of parts for all its models. W. R. Daniels, treasurer of the Prentiss Motor Car & Supply Company, which has represented the Studebaker line in Boston, will become manager of the branch.

The removal of the Studebaker agency from Berkeley street near Tremont about closes out that automobile section, which once was the home of such well-known cars as the White, Buick, Locomobile, Aerocar, American Mors, and others. Nearly

all these cars are now sold in the newer section in the vicinity of Boylston street and Massachusetts avenue.

Another interesting New Year's change is the opening of the new Thomas agency, also in upper Boylston street. The agency for the Thomas is in the hands of the Whitten-Gilmore Company, composed of Charles Whitten, long and favorably known as an automobile dealer in Lynn, and E. A. Gilmore, recently connected with the White Company in New York and previous to that manager of the Rambler New England branch in Boston. The company's new store, which has been remodeled for it from an apartment house, is next to the salesrooms of the J. W. Bowman Company, agents for the Stevens-Duryea.

Still another newcomer on Boylston street is the branch of the Panhard & Levassor American agency. George T. Gould comes from New York as the manager of the branch and the company is preparing to make a greater effort than ever before to secure a larger share of the Boston business for foreign machines. H. C. Stratton, who handles the American Mercedes, Car de Luxe and Kissel Kar, has also moved to Boylston street from the quarters he occupied formerly in the building of the Back Bay Automobile Company on Huntington avenue.

### WALTER C. WHITE'S EUROPEAN IMPRESSIONS.

Walter C. White, second vice-president of The White Company, has returned from his annual visit to the London and Paris shows. In speaking of his trip Mr. White said:

"Although there is undoubtedly an oversupply of certain types of cars in the European market, the business in White steamers is unaffected. On the contrary, foreign business is growing season by season as the advantages of our distinctive type become more widely recognized. During the last season the White won all three of what are known as the 'desirability contests,' namely, the London Town Carriage competition, the Dust Trials, and the South Harting hill-climb. The latter was primarily an efficiency contest wherein first award was made to the White because it developed at the rear wheels a greater proportion of its assigned horsepower than did any other car, the rating assigned to the White by the Royal Automobile Club, which conducted the test, being 50 horsepower. The prize in the latter contest, by the way, known as the Yellow Trophy, is one of the handsomest I have ever seen. It is a massive gold cup of classic design and some idea of its value may be gathered from the fact that, before placing it on exhibition we insured it for £500 sterling."

### EFFECTIVE HOLIDAY WORK OF THE AUTOS.

INDIANAPOLIS, IND., Dec. 30.—At Christmas time the automobile plays a very prominent part in promoting happiness among the unfortunates of the city, in addition to expediting the delivery of parcels for the department stores. In connection with its Christmas charity work, the *Star* this year took the inmates of the Indiana Institute for the Blind to the various charitable and penal institutions of the city to sing carols.

Automobiles were loaned by the Premier Motor Manufacturing Company, the National Motor Car Company, the Indiana Automobile Company, Gibson Automobile Company, Nordyke & Marmon, Hugh J. McGowan, and Louis G. Beschler.

The Indianapolis *News*, each year, from contributions given by the public, purchases provisions and gives them to old and unfortunate people of the city. This year the work of delivering the 200 baskets was done voluntarily by the Premier Motor Manufacturing Company, about a dozen Premier touring cars being loaned for the purpose.

### POPE-TOLEDO MAY PARTICIPATE IN GRAND PRIX.

TOLEDO, O., Dec. 30.—From the Pope Motor Car Company the following press notice has appeared:

"It is said there is some talk of the Pope-Toledo all-chrome-nickel steel racer being leased by a French syndicate for racing purposes on the Continent. This is the racing car built by the Pope-Toledo for the 1907 Vanderbilt race, which was postponed. The car was pronounced by experts to be the finest racing machine ever built. While nothing, one way or the other, can be learned from either parties, it is very doubtful if the owners will permit this car to leave America unless it goes to bring home a foreign cup."

The impression prevails that the Pope Company intends to make an entry in the Grand Prix of France, to be held in July next. It will be remembered that Lytle and Dingley were Pope-Toledo racers in the Gordon Bennett race of 1905, and the company has always been greatly interested in speed contests. It is expected in the near future a definite announcement may be made concerning the Grand Prix entry.

### PHILADELPHIA'S LATEST BIG GARAGE.

PHILADELPHIA, PA., Dec. 30.—That the financial flare-up has not materially affected the local automobile trade was demonstrated last Thursday, when the first spadeful of earth was turned in digging the foundations for what will be one of the largest garages in the United States. No less than eight buildings now standing at Nos. 229 to 243 North Broad street will be torn down to make room for the improvement. Henry C. Lea is head of the concern which will operate this enormous garage, which will be erected by the William Steele & Sons Company, after plans by Watson & Huckel, architects.

The North Philadelphia Auto Station was last week awarded the local agency for the Garford car. David Sykes and Frank Le Flem are at the head of this concern, which has a garage and salesroom at 3425 North Broad street.

### A FOUR-YEAR-OLD AUTO OWNER.

BOSTON, Dec. 30.—It is believed that the youngest owner of an automobile in Massachusetts is the four-year-old son of Dr. George L. Black, of Lawrence, who recently came into the possession of a new Maxwell runabout by holding the winning ticket in a contest run by the Knights of Columbus of Salem.

## BRIEF ITEMS OF NEWS AND TRADE MISCELLANY

The Holsman Automobile Company's factory at Chicago was shut down during the holiday week just past, in order to give an opportunity for inventory taking.

The San Francisco branch of the Winton Company is now housed in its permanent home at Van Ness and Grove avenues. This building was erected on plans devised by the Winton people and is one of the best arranged motor car establishments in the West.

The Walden W. Shaw Company, Chicago, are now occupying their new quarters at Twenty-first street and Michigan avenue, where the full lines of the Berliet, Reo and Premier cars are on exhibition. The Shaw company now occupies the most southerly location on the "row" and has one of the finest automobile buildings in Chicago.

Among the prominent American cars on which the Truffault-Hartford shock absorbers are now fitted as part of the regular equipment are the Pierce Arrow, Studebaker, Stevens-Duryea, Stoddard-Dayton, Marmon, Locomobile and Acme—a list of which the makers of the shock absorbers may well point to with pride.

The \$2,500 contest for the drivers of Winton "Six-teen-six" cars will soon be on in earnest, the awards being scheduled for July 1, 1908. The ten drivers who show the smallest repairs on at least 3,000 miles running will divide the money, the first prize being \$1,000; second, \$500; third, \$250; fourth, \$150, and the fifth to tenth, \$100 each.

"Increased sales of high-grade tires and hard times would hardly seem to go together very well," says E. H. Broadwell, "but whatever effect the financial depression may have upon the sale of automobiles, the sales of the highest-priced tires are better now than they were at the corresponding time last year, and the prospects are that they will better throughout 1908."

Manager Frank Eveland of A. G. Spalding & Bros. is very enthusiastic over the proposed spring show to be held at some such place as Morris Park in connection with a race meet, both to be conducted by the New York Automobile Trade Association. "Unquestionably it is the very thing the dealers and the public will want at that time of the year," said Mr. Eveland.

After one of the most strenuous runs imaginable, the White steamer which recently left Chicago with the Stepeny spare wheel expedition, arrived at St. Louis. The party consisted of Edward Grant, Edward Van Lunn, L. F. Chaney and a representative of the Chicago Motor Club. Both the car and the spare wheel came through the test in fine style, but the men were exhausted from the exposure.

A new and pleasingly colored hanger just issued by Wheeler & Schebler, Indianapolis, Ind., neatly illustrates the "heart of the automobile" by drawing the bonnet of the auto shown in the picture in heart-shaped form and depicting a Schebler carburetor in gold color on its front. A typical automobile girl with hand grasping the steering wheel is stepping aboard the machine. The design of the whole subject is very effective.

The Jeannin Automobile and Manufacturing Company, 1223 No. Vandeventer avenue, St. Louis, Mo., has been incor-

porated, and commenced to manufacture a two-cylinder motor of the double-opposed type with offset cylinders, especially designed for use in the buggy type of automobiles. Later it is the intention of the company to bring out a small delivery car, and also some other automobile parts. E. P. Fritschle is president; H. W. Jeannin, superintendent, and W. Goener, secretary.

"Keep your motor warm," is the advice of H. E. Coffin, vice-president of the E. R. Thomas Detroit Company. "In the winter weather, when a car is run at speed, the cooling properties of the radiator are much greater than in warmer weather. A motor will run better and start easier if a sheet of cardboard or other light material covers part of the radiator." Mr. Coffin says this advice applies particularly to the Thomas Detroit, the unusually effective cooling system of which is designed to keep the motor cool when run to the limit of its power in the hottest climates.

The Michelin demountable rim, which is being placed on the market by the Michelin Tire Company, is receiving emphatic commendation from autoists at the Importers' Salon this week. The device is so designed that it combines ease of removal with closeness of adhesion—a positive fastening to the wheel rim. The extra rim is carried with its tire attached and already inflated. In case of puncture several bolts are loosened, the old tire slipped off, and the new tire, fully inflated, is slipped on, rim and all. The bolts are then tightened and the operation is complete. The time saved alone is a great factor.

"Whatever may be said about the effect of the recent financial flurry on the sales of pleasure motor vehicles in general," said an official of the Studebaker Company recently, "there is one type of automobile that is receiving more attention than ever before, and that is the electric delivery wagon and truck. Business men are coming to regard this type as a money earner for its owner. Up-to-date concerns all over the country, who have studied the subject of local transportation in all its various phases, are now substituting the electric power wagon for horse delivery; not alone because it gives more satisfactory service, but mainly because it is in the interest of business economy to do so."

One big move that marked the first day of 1908 on New York's automobile row was that of the Rainier Motor Car Company from Broadway and Fiftieth street to its new home on the corner of Fifty-sixth street and Broadway. Although the present Rainier place was built especially for the company a few years ago, it has so far outgrown it that the business had to be distributed through three different buildings. In the new five-story headquarters all this business of salesrooms, offices, garage and machine shop will be gathered under one roof, and the facilities for the company's policy of keeping customers' cars in repair will be greatly improved.

### NEW AGENCIES ESTABLISHED:

During the past week three new agencies have been added to the dealers' list of the Franklin Automobile Company, as follows: J. Mount, Red Bank, N. J.; Robert Harmon, Portland, Me.; Guy L. Smith, Omaha, Neb.

The Studebaker Automobile Company has opened a local salesroom in Cleveland for the sale of its electrics. The location is on Euclid avenue near Twentieth street, and Alvin H. Smith, formerly of the Central Automobile Company, will be manager.

The Rambler Automobile Company, Omaha, Neb., has just taken the agency for the Mitchell line of cars, and as buyers in this territory are keen for medium-priced cars that do not balk on the numerous lovely specimens of hills with which the country abounds, the Mitchell cars, which have already shown their ability in this line, will be largely favored.

The Northern Motor Car Company has just closed an agency contract with the Chicago Vulcanizing Company which will put its sign up in Chicago's automobile district in the near future under the name of the Northern Automobile Company. The company will represent the Northern in Chicago, and in the greater part of the State of Illinois. Other Northern agencies just placed are the Oklahoma Motor Car Company, Oklahoma City, Okla.; Humphreys, Schloot & Company, Linton, Ind.; C. J. Layton, Danville, Ill.; H. C. Griesinger, Santa Cruz, Cal.

### PERSONAL TRADE MENTION.

H. M. Chambers, who has long been identified with the automobile business in Chicago, has joined the selling force of the Studebaker Chicago branch.

B. F. Blaney, who has been connected with the Corbin Motor Vehicle Company, of Boston, 87 Church street, the Motor Mart, as secretary, has just severed his connections with that concern. His plans for the future will be announced a little later.

Herbert L. Averill, sales manager of the York Motor Car Company, York, Pa., has returned from a week's business trip to Buffalo and the middle west, in the interest of the Pullman. He is one of the official observers in the New Year's endurance run of the Quaker City Motor Club of Philadelphia.

The E. R. Thomas Detroit Company has added to its force W. H. H. Hutton, for five years purchasing agent of the Northern Motor Car Company, and recently manager of the Port Huron factory. He will work in connection with F. O. Bezner in the purchasing department of the Thomas-Detroit factory.

David J. Moreland, for several years field representative of the Rapid Motor Vehicle Company, Pontiac, Mich., has been promoted to the position of superintendent, a position well earned by faithful service and exceptional knowledge of the Rapid line. It is the intention of the Rapid Motor Vehicle Company to greatly increase its output in 1908.

Edgar Apperson, of the Apperson Brothers Automobile Company, of Kokomo, Ind., left last week for a visit to Los Angeles, where he will remain about a month. Though his trip is principally undertaken for pleasure, he will look into automobile conditions on the Pacific Coast very carefully, particularly as they apply to the sale of Apperson cars, while he is in that territory.



NEW TRADE PUBLICATIONS.

An interesting booklet entitled "About Graphite Paint" has been published by the United States Graphite Company, Saginaw, Mich., and will be sent upon request to all those interested in this subject.

Rambler lines for 1908 are given an advance presentation in a catalogue just issued from the Thomas B. Jeffery & Company factory at Kenosha, Wis. The two and four-cylinder models are described and illustrations given of the various touring cars and roadsters.

"The Shooting Oiler" is the title adopted by the Precision Appliance Company, Chicago, in describing the Hill pre-

cision oiler for automobiles and motor boats. A full description of the mechanical features of the oiler is given in the booklet, all the mechanical parts being illustrated.

How Logan three and one-ton trucks are built, how they are operated, and what they are capable of doing, forms the subject matter of the catalogue of the Logan Construction Company, at Chillicothe, O. A correct idea of the structural features of the trucks can be gained by the numerous halftone illustrations.

Among a batch of Babcock publications, the most noticeable feature is a dainty blue and gold-covered catalogue on the electrics produced at the Bab-

cock Electric Carriage Company's works, Buffalo, N. Y. A striking two-page illustration shows a group of Babcock electrics, evidently in the hands of satisfied owners, photographed in Delaware Park, Buffalo.

The account of how one lady went through the Glidden tour is told in an illustrated folder published by the Rainier Company by Mrs. J. N. Cuneo herself. The lady driver has something to say on the way her Rainier stood up under the terrible pounding to which it was subjected in the sixteen-day run from Cleveland to New York; but the illustrations reveal, even better than words, the severe ordeal to which both car and driver were put.

INDEX ADVERT

Table listing various companies and their page numbers, including Acetylene Gas Illuminating Co., Acme Motor Car Co., Adams Co., Add-Wear Auto Tire Sleeve Co., Aerocar Co., Ajax-Grieb Rubber Co., American Ball Bearing Co., Am. Brass & Alum. Works, American Die Castings Co., American Distributing Co., American Motor Truck Co., Anderson Forge & Machine Co., Apperson Bros. Automobile Co., Ashtabula Bow Socket Co., Ashton Valve Co., Auburn Automobile Co., Audel & Co., Theo., Aurora Motor Works, Auto Pump Co., Autocar Co., Autocar Equipment Co., Automobile Blue Book, Automobile Supply Co., Automobile Supply Mfg. Co., Automobile Utilities Co., Auto-Shine Co., Avery Portable Lighting Co., Babcock Electric Carriage Co., Baker Motor Vehicle Co., Baldwin Chain Mfg. Co., Barnett Drop Forging Co., Bartholomew Co., Beaver Mfg. Co., Behen-Faught Motor Car Eq. Co., Bellfuss Motor Co., Bellefontaine Auto Co., Bemus, T. A., Bealy & Co., C. H., Bethlehem Steel Co., Billings & Spencer, Blasier Mfg. Co., M. E., Blomstrom Mfg. Co., Bokor & Co., H., Bosch, Robert, Boston Auto Gage Co., Bowser & Co., S. F., Boyle & Co., John, Briscoe Mfg. Co., Brownell Motor Co., F. A., Buckeye Jack Mfg. Co., Buckeye Mfg. Co., Buffalo Carbureter Co., Bullard Automatic Wrench Co., Bullard, J. H., Buob & Scheu, Byrne-Kingston Co., Cadillac Motor Car Co., Cameron Car Co., Canton Drop Forge & Mfg. Co., Central Body Co., Chadwick Engineering Works, Champion Co., A., Chandlee & Chandlee, Clark, E. S., Cleanola Co., Cleveland Motor Car Co., Cleveland-Canton Spring Co., Columbia Lubricants Co., Comptoir d'Innovations pour Automobiles, Conn. Tel. & Elec. Co., Conover Motor Car Co., Continental Caoutchouc Co., Continental Motor Car Co., Continental Motor Mfg. Co., Corbin Motor Vehicle Corp., Cornish-Friedburg Motor Car, Correspondence School of Motor Car Practice, Cotta, Chas., Cowles & Co., Crown Battery Co., Crown Soap Co., Cullman Wheel Co., De Luxe Motor Car Co., Diamond Chain & Mfg. Co., Diamond Rubber Co., Dien, Ch., Dietz Co., R. E., Dixon Crucible Co., Joseph, Dorris Motor Car Co., Dover Co., Geo. W., Dow Portable Electric Co., Duff Mfg. Co., Duplex Coil Co., Eclipse Machine Co., Eco Mfg. Co., Edgar Mfg. Co., Edmunds & Jones Mfg. Co., Eldredge Electric Mfg. Co., Electric Vehicle Co., Ellsworth, J. M., Elmore Mfg. Co., Empire Automobile Tire Co., Ericka Mfg. Co., Excelsior Supply Co., Firestone Tire & Rubber Co., Fisk Rubber Co., Forest City Motor Car Co., Franco-Am. Auto Supply Co., Franklin Mfg. Co., H. H., Fry, T. C. & W. L., G & J Tire Co., Gabriel Horn Mfg. Co., Garford Motor Car Co., Gearless Transmission Co., Geisler Bros., General Accumulator & Battery Co., Gibney & Bros., Jas. L., Graves & Congdon Co., Grout Bros. Auto Co., Ham Mfg. Co., C. T., Hardy Co., The R. E., Harris Oil Co., A. W., Hartford Auto Parts Co., Hartford Rubber Works Co., Hartford Suspension Co., Hatfield Motor Vehicle Co., Healy Leather Tire Co., Heinze Electric Co., Heltinger Carbureter Co., Hercules Auto Specialty Co., Herz & Co., Hess-Bright Co., Hicks Speed Indicator Co., Hoffecker Co., Hoffman, Geo. W., Holley Bros. Co., Holsman Automobile Co., Hopewell Bros., Hotchkiss Mfg. Co., Hotel Fredonia, Hotel Rudolph, Hotel Tampa Bay, Hotel Tower, Hotel Westminster, Howard Motor Works, Hub Lubricator Co., Hyatt Roller Bearing Co., Imperial Motor Car Co., Indestructible Steel Wheel Co., Index Speed Indicator Co., Jackson Automobile Co., Jamesville Mfg. Co., Jeffery & Co., Thos. B., Jeffery-Dewitt Co., Jenckel Motor Mfg. Co., Jersey Brake Co., K. W. Ignition Co., Kellom Co., Chas. F., Kent Mfg. Works, A., Kimball Tire Case Co., King Top Mfg. Co., Kinsey Mfg. Co., Kinsler-Bennett Co., Konigsow, Otto, Lavalette & Co., Lavigne Mfg. Co., Lear Automobile Co., Oscar, Leather Tire Goods Co., Limousine-Carriage Mfg. Co., Lipman Mfg. Co., Lobee Pump Co., Locke & Co., Lockwood Bros., Locomobile Co. of America, Logan Construction Co., London Auto Supply Co., Long Mfg. Co., M. & M. Mfg. Co., McClellan, Chas. P., McCord & Co., Maja Co., Mandeville Steering Wheel Muff Co., Manhattan Electrical Sup. Co., Manhattan Screw & Stamping Co., Manhattan Storage Co., Martini Import Co., Masury & Son, John W., Maxwell-Briscoe Co., Mayo Radiator Co., Merchant & Evans Co., Merritt & Co., Mezger, C. A., Michelin Tire Co., Migley Mfg. Co., Miller Bros., Miller, Chas. E., Mitchell Motor Car Co., Model Automobile Co., Moline Automobile Co., Moon Motor Car Co., Mora Motor Car Co., Moran & Wright, Mosler & Co., A. R., Moss Photo Engraving Co., Motor Car Equipment Co., Motz Clincher Tire & Rub. Co., Mound Tool & Scraper Co., Muller, Albert, Muttly Co., L. J., Myers Auto Top Co., National Auto Accessories Co., National Battery Co., National Brake & Clutch Co., National Carbon Co., National Motor Vehicle Co., Neustadt Auto & Sup. Co., Never-Miss Spark Plug Co., New England Motor Co., N. Y. Gear Works, N. Y. Sporting Goods Co., N. Y. & N. J. Lub. Co., Nichols & Co., D. P., Nordyke & Marmon Co., Northway Motor & Mfg. Co., Nuttall Co., R. D., Ofeldt & Sons, Old Colony Light Co., Olds Motor Works, Owen & Co., R. M., Pacific Tucking & Mfg. Co., Packard Electric Co., Packard Motor Car Co., Palmer & Singer Mfg. Co., Pantasote Co., Parish & Bingham Co., Parker, Stearns & Co., Peerless Motor Car Co., Penn. Auto Motor Co., Perfection Grease Co., Perfection Spring Co., Pettingill-Andrews Co., Peugeot Freres, Pfanstiehl Elec. Laboratory, Picrome Hilde Co., Pierce Co., Geo. N., Pierce Engine Co., Pine Woods Inn., Pioneer Brass Works, Pirelli & Co., Pittsfield Spark Coil Co., Pope Motor Car Co., Precision Appliance Co., Prest-O-Lite Co., Progressive Mfg. Co., Prosser & Sons, Thos., Quad Mfg. Co., Quinby Co., J. M., Raimes & Co., Rainier Co., The, Rajah Auto Supply Co., Randall-Falchney Co., Reeves Pulley Co., Reliance Motor Car Co., Remington Tool & Machine Co., Remy Electric Co., Renault Freres, Richardson Engineering Co., Robert Instrument Co., Roberts Motor Co., Rose Mfg. Co., Ross Gear & Tool Co., Royal Battery Co., Royal Equipment Co., Rushmore Dynamo Works, Salisbury Wheel & Mfg. Co., Samson Leather Tire Co., Sanford Mfg. Co., F. C., Saxon Lamp Co., Schacht Mfg. Co., Shaler Co., C. A., Shawver Co., Smith Automobile Co., Smith Co., A. O., Smith & Sons, S., Speed Changing Pulley Co., Spicer Universal Joint Mfg. Co., Splittdorf, C. F., Sprague Umbrella Co., Springfield Portable House Co., Standard Automatic Lub. Co., Standard Battery Connection Co., Standard Co., Standard Connecting Rod Co., Standard Roller Bearing Co., Standard Welding Co., Steam Carriage Boiler Co., Stearns Co., F. B., Stevens-Duryea Co., Stewart & Clark Mfg. Co., Streit Machine Co., A., Studebaker Automobile Co., Success Auto Buggy Co., Supplementary Spiral Spring, Swinehart Clincher Tire Co., Thomas Motor Co., E. R., Thompson Sons Co., J. P., Timken Roller Bearing Axle, Tincher Motor Car Co., Trebert Gas Engine Co., Troy Carriage Sunshade Co., Tucker, C. F., U. S. Fastener Co., Uncas Specialty Co., Veeder Mfg. Co., Vehicle Specialty Corp., Walker Co., E. C., Warner Instrument Co., Warner Pole & Top Co., Waukesha Motor Co., Wayne Automobile Co., Weeber Mfg. Works, C. F., Weed Chain Tire Grip, Welch Motor Car Co., Western Motor Co., Weston Elec. Instrument Co., Wheeler & Schebler, White Co., The, Whitney Mfg. Co., Winton Motor Carriage Co., Cover, Witherbee Igniter Co., Wright Cooler & Hood Mfg. Co., Wyman & Gordon Co., York Motor Car Co.

## SPECIAL NOTICES

Advertisements inserted under this heading at 20 cents per line; about 7 words make a line. Remittance should accompany copy. Replies forwarded if postage is furnished.

### Cars for Sale

**ABSOLUTE** closing out sale of the largest stock of new and second-hand automobiles in the United States; write for Clearance Sale List No. 20; now is the time to buy. Rochester Automobile Co., Jos. J. Mandery, Prop., Rochester, N. Y.

**A BARGAIN**—1907, 20-h.p., 4-cylinder Model G Cadillac runabout; best of condition; demonstration at any time. Address Morgan & Wright, 214 West 47th St., New York.

**AUTOMOBILE**—Four-cylinder Pierce limousine; just completely overhauled. Address 916 Frick Bldg., Pittsburg, Pa. Telephone, Court 1052.

**AUTOMOBILES**—No reasonable offer refused; Franklin runabout and touring car; Pope-Hartford, single and four cylinders; Electric, Cadillac, Doctor's Stanhope, Compound '07; lot of tires, all sizes. P. O. Box 540, Hartford, Conn.

**AUTOMOBILES**—30-h.p. Pierce-Arrow, 1906, \$2,000; 24-h.p., 4-cylinder Ford, \$600; 26-h.p. Rambler, \$700; 50-h.p. Thomas Flyer, \$1,500; Cadillac delivery car, \$350; 30-h.p. Model H Cadillac, \$1,500; 30-h.p. Peerless, \$1,000; these are great bargains, but must be sold. E. R. Clark Auto Co., 461 Worthington St., Springfield, Mass.

**AUTOMOBILES** at your own price. We have a complete assortment of slightly used and second-hand automobiles which will be sold regardless of their value, as we MUST have the room; positively the greatest opportunity ever offered; come early and secure a bargain. If you cannot come personally, communicate with us at once. The Starin Company, 1034-1100 Main St., at St. Paul St., Buffalo, N. Y.

**BARGAINS**—Packard runabout, Packard touring, 1907, cheap; Rainier touring, Buick runabout, Lozier touring, Thomas limousine, Ford runabout, new, \$400. Vanderveer Bros., Times Bldg., 42nd St. and Broadway, New York City.

**BUFFALO SALES DEPARTMENT** demonstrator; refinished and thoroughly overhauled; complete catalogue equipment, including cape top and glass front; list price \$5,500; will sell at \$4,000. The George N. Pierce Company, Buffalo, N. Y.

**BUICK MODEL F**—New; never used; regular factory equipment; 1907 model; regular price \$1,250; will take \$900. "A." care The Automobile.

**BUICK**—Four-cylinder, Model D; equipped with gas and oil lamps, gas generator, extra tire, Allen tire holders and tire cover, Veeder dash odometer, \$125 top complete; run 987 miles, and is as good as new; cost, as equipped, \$2,275; sell for \$1,350; guaranteed all O.K. "B." care The Automobile.

**CADILLAC RUNABOUT**—Model K, excellent condition; complete with top, lamps and generator. The Hartford Rubber Works Co., Hartford, Conn.

**ELMORE**—1906, 24-h.p.; top, extra tire; in fine shape. J. F. McGurk, Shortsville, N. Y.

**FINANCIAL STRINGENCY** compels us to offer panic prices in Ford 6-cylinder, Franklin D. Maxwell H. and runabouts; Olds and Cadillac runabouts; it will pay you to write for list; we have bargains you can't duplicate. Automobile & Garage Co., Meyersdale, Pa.

**FLANDAU BROUGHAM**—Cost \$1,500 when new; only been run a short time; also new Victoria, never has been run, worth \$1,000; for sale, or will exchange for automobile high power gentleman's roadster. Address C. D. Jones, 701 Connell Bldg., Scranton, Pa.

**FORD RUNABOUT**—Four cylinders; searchlight, generator, side and tail lamps; condition perfect; color, dark green; \$385, cash. H. Coulson Fairchild, Passaic, N. J.

**FORD RUNABOUT**—1907, Model N; nearly new; bargain. 252 Fallsdale Ave., Jersey City, N. J.

### GARFORD WEEKLY LIST OF SECOND-HAND CARS:

75—Cleveland touring car, 1907 model, 30 to 35-h.p., excellent condition; exceptional opportunity; nearly new. \$1,275  
76—Packard Model N; excellent condition ..... 950  
77—Packard runabout, 1907 model; used but few months ..... 2,750  
78—Ford 6-cylinder, 1907 model; used but three months ..... 1,750  
79—Rainier 1906 limousine; thoroughly overhauled ..... 2,000  
80—Rainier 1907 touring car; fine condition ..... 1,800  
81—Hotchkiss demi-limousine, 1906 model; fine condition ..... 3,400  
82—Dorris, 30-35, 1907 model; five months old ..... 850  
83—Packard touring car, 1906 model... 1,500  
84—Packard touring car, 1907 model... 2,500  
Also cars of many other makes at from \$500 up. The above cars have been placed with us for sale by parties ordering Garford cars. In making inquiries kindly mention serial number of car you may be interested in. Garford Motor Car Company of New York, 1540 Broadway, New York City.

**GET WISE**—We have anything you want in second-hand cars—Packard, Winton, Locomobiles, White steamers, Franklins, Buicks, Oldsmobiles—and bargains at that. Get our list for March. The Sid Black Automobile Co., 630 Walnut St., Cincinnati, Ohio.

**LATEST MODEL**, 28-h.p. Rainier landaulet; cost \$4,500; used four months; perfect condition; just painted; price \$2,200. R. Hager, 1 West 73d St., New York City.

**MAXWELL RUNABOUTS**—RL and RS; brand new; bargains. Address "R. M. S." care The Automobile.

**ONE EIGHT-PASSENGER** touring car; tires practically new, 5-inch on rear, 4-inch front; cost to build, \$3,500; sell for \$350; guaranteed in first-class condition. "D." care The Automobile.

**PACKARD CARS** for sale—Packard cars in good condition at moderate prices, by people who have ordered 1908 Garfords. Inquire Garford Motor Car Co. of New York, 1540 Broadway, New York City.

**PIERCE GREAT ARROW**—1906 model, 32-h.p., perfect condition; cost, with equipment, \$4,600. Address 72 Weissinger-Gaulbert, Louisville, Ky.

**POPE-HARTFORD** touring car; side entrance; top, lamps, horn, etc.; used one season; fine condition; will sell for \$900, if taken at once. Lanpher Bros., Carthage, Mo.

**POPE-TRIBUNE RUNABOUT**—New; 1-cylinder, 6-h.p., 1905; 2 speeds and reverse, 750 pounds; easy riding, reliable, good power; \$200; cost \$500; reason, use touring car. H. M. Rich, Morrisville, Vt.

**RAINIER LIMOUSINE**—35-h.p., 1907 model, Burr body; in first-class condition; seats six; price \$2,800. Diefenderfer, 244 West 49th St., New York.

**RAMBLER TOURING CAR**—25-h.p., 4-cylinder, with complete equipment; 1906 model; to be sold at a sacrifice. Address Box 656, Waterbury, Conn.

**SPECIAL SACRIFICE** of automobiles—Among the 250 cars here are over 50 on which owners will accept any reasonable offer, and which must be sold at once. Take advantage of this opportunity to get an automobile at your own price. If you cannot call and inspect, send for our special weekly bargain list, Manhattan Storage Co., 334-340 West 44th St., New York City.

**STANLEY TOURING CAR**, 1907, at \$1,200; one Stanley speedster, at \$1,000; both in first-class condition, with full equipment. Address A. M. Bernard, Minneapolis, Minn.

**STEVENS-DURYEA**—1906, 4-cylinder touring car; good equipment; extra low price if sold at once. J. S. Harrington, 36 Central St., Worcester, Mass.

**STEVENS-DURYEA**—1906, Model R, 4-cylinder car; complete with top, Prest-O-Lite gas tank, Warner speedometer, and trunk rack; tires as good as new; price, \$1,250. R. W. Magna, Holyoke, Mass.

**WE ARE TAKING** in second-hand automobiles of all makes in exchange for new ones, which we will sell very reasonably. F. E. Lockwood & Co., 39 Wall St., Norwalk, Conn.

**WHITE STEAMER**—Model F; complete with all touring equipment; \$1,200. Auburn Automobile Co., 56 Water St., Auburn, N. Y.

**WHITE STEAMER**—New Model G, in best of condition; cost, two months ago, \$6,000; extra large Studebaker limousine; for sale, cheap. 10 East 83d St., New York City.

**WHITE STEAMER**—1903; canopy top, side baskets, dust deflector, Rushmore lamps, three new and one retreaded tire; cost, new, \$2,350; sell for \$350; guaranteed in first-class condition. "C." care The Automobile.

**WHITE STEAMER**—1906; bargain; including the following accessories: Prest-O-Lite tank, 5 lamps, Warner speedometer, Sprague extension top, shock absorbers and automatic pump; car has completed 5,840 miles; tires pumped by engine; open to minutest inspection; price on application. J. S. Harrington, 36 Central St., Worcester, Mass.

**WILL SACRIFICE** my 1906, 50-h.p. Thomas, with fine equipment, and in perfect running order, for \$1,500. Address "Thomas." care The Automobile.

**1906 ROYAL TOURIST**, 45-h.p. touring car; 1906 Stoddard-Dayton 35-h.p. touring car; 1907 Maxwell runabout; all cars fully equipped and in the best of condition; make offer. C. M. Vanderslice, Pottstown, Pa.

**1907 \$2,500 STODDARD-DAYTON** runabout; entire car in perfect condition. Penn Automobile Co., Inc., Reading, Pa.

**1907 LOCOMOBILE LIMOUSINE**—Immediate delivery on a Type E limousine, with extra touring body; car has been used very little; cost \$4,300; will sell for \$2,900; guaranteed in A-1 condition, and subject to inspection. C. B. Gleason, 702 Grand Ave., Milwaukee, Wis.

**1907 STODDARD-DAYTON** speedster, with rumble seat and extra tourabout seat for three passengers; full lamp equipment; fine condition; cheap. Model K Winton, with top; full lamp equipment; looks like new; fine condition; price, \$900. Reading Automobile Co., Reading, Pa.

**1907 ROYAL TOURIST**—In fine condition, only used 3,000 miles, cape top and cover; 1907 Model L Pope-Hartford, only used for demonstrating purposes, in fine condition; 1907, Model U, 6-cylinder Stevens, only used for demonstrating, newly varnished; 1907, Model R, 4-cylinder Stevens, only used for demonstrating purposes, newly varnished. Address Maine Motor Carriage Co., Free and South Sts., Portland, Me.

**\$100 REDUCTION** given on a 1908 Model HUC Maxwell touring car; complete with top, front curtains and Michelin tires; to be delivered April 1, 1908, or later. A. Kratochvil & Son, 446-48 West 26th St., Chicago, Ill.

**\$100 TO \$500 SAVED**—Buy a good new or second-hand car for next season's use. Write me to see how much I can save you on others' sacrifice prices. Light touring cars, 7-passenger cars, and gentlemen's roadsters, including Thomas, Pierce, Packard, Peerless and other standard makes, from \$640 to \$1,680; smaller cars taken in trade. C. T. Paxton, 1200 Niagara St., Buffalo, N. Y.

**\$400 BUYS A FRANKLIN** 4-cylinder Model A runabout; write for photo and description. The Potomac Hardware Co., Cumberland, Md.

**\$750 TAKES** my Model F Buick 5-passenger touring car; bought new Sept., '06; has run 4,000 miles; in absolutely first-class condition; reason for selling, am buying 4-cylinder car, same make. J. E. B. Wright, Amarillo, Tex., Box 491.

**\$4,000 50-H.P.**, 7-passenger Acme touring car, with extra runabout body; top and curtains, five lamps, generator, horn, tire carrying irons and tools; car in fine condition, tires good as new; must sell quick; best cash offer takes car. S. M., Box 356, Reading, Pa.

### Cars Wanted

**AUTOMOBILES WANTED**—Spot cash ready. Broadway Mammoth Automobile Exchange, 247 West 47th St., Telephone, 3097 Bryant, New York City.

**WRECKS WANTED**—Will buy them, regardless of condition. Portland Garage Co., Portland, Me.

**WANTED**—A good touring car, in all or part exchange for a fine plantation. H. A. Brinkerhoff, Texarkana, Tex.

**WANTED**—Good make, 7-passenger touring car, fully equipped and in first-class condition, in exchange for 240 acres of good land near Houston, Texas; a real bargain for some one. Describe your machine fully. A. Van Camp, Decatur, Ind.

**Parts and Accessories**  
(FOR SALE)

**A BARGAIN IN TIRES**—We have a quantity of new tires to sell cheap, while they last; write us for prices. Empire Tire Repair Co., 1615 Wabash Ave., Chicago.

**A FEW** new limousine bodies; high grade aluminum construction, painted and trimmed in the finest leathers and cloths; body measures, when fitted to chassis, 32 inches by 82 inches; immediate deliveries; terms, cash. Address J. B. Richards, Springfield, Mass.

**AUTO TOPS** from \$25 up; also recovering and repairing; prompt and satisfactory service and lowest prices guaranteed; a specialty of automobile upholstery. Paris Auto Top Co., 312 West 53d St., New York City. Phone, 6444 Columbus.

**AUTO TIRES**—I have just secured a lot of new seconds; all fine tires; 1907 Dunlop and clincher style; selling at bottom prices. Order now. Repairing and recovering old tires by competent workmen. Special attention to orders by mail. W. M. Sharpe, 118 West Broadway, New York City.

**BIG SNAP**—Buick top cheap; new, 1907, \$100 style. Sacrifice, \$68.50; no less. Guaranteed as represented. Bank references. (Illinois), care Automobile.

**BIG SNAP**—Two new, soiled Hartford Dunlop, 30x3 1-2 Q. D. casings; four new, soiled tubes, same. Casings, \$26.50 each; tubes, \$5.50 each; no less. Guaranteed as represented. Bank references. Address "Illinois," care The Automobile.

**BODIES**—We have disposed of all of the touring car bodies we have been advertising in these columns, at bargain prices, with the exception of five Model L tonneau bodies seating five passengers. These are finished in Quaker green, with black trimmings, and upholstered in genuine leather and curled hair. Dimensions, where body rests on chassis, 80 inches in length by 34 1-2 inches in width. We offer them at \$50 each, while they last. Prices, cash with order, f.o.b. cars Waltham, crated. Illustration and blue-print showing all body dimensions sent upon request. Waltham Mfg. Co., Waltham, Mass.

**DOUBLE-ACTING** steam engine, 14-h.p., Ofeldt flash boiler and burner complete, size of boiler 22x22x18, and a Peter Forge 16-inch burner, practically new; write or call for particulars. Michael J. Benn, 166 Vanderveer Pl., Brooklyn Manor, L. I., N. Y.

**FORD RUNABOUTS**—You need a perfect ratchet brake pedal for your Ford; we furnish you one for \$3; applied by novice in half hour; satisfaction, or money back. S. S. Auto Co., Alliance, O.

**GLASS FRONTS**, \$12; simple, durable, correctly made, and easily attached, to fit any car; discount to dealers. The Motor Shop, 232 Massachusetts Ave., Indianapolis, Ind.

**NON-SKIDS**—We make the best on the market; case-hardened steel rivets, toughest and waterproof leather used; finest workmanship. Our rubber retreading excels all others. We can save you money on new tires. Vulcan Tire Repair Works, 226 West 53d St., corner Broadway, New York City.

**ONE 6-CYLINDER**, high-tension magneto, "Remy"; price reasonable. Auto Engine Works, St. Paul, Minn.

**ONE 10-H.P. HORIZONTAL** motor, 5 1-2-inch bore, 6 1-2-inch stroke, in first-class repair, including carbureter, pump, spark plug and vibrator coil, a bargain at \$50. Olean Garage Company, Olean, N. Y.

**STANLEY 12-inch** tubular boiler, used to run model engines in shop for experimental purposes; never used more than ten hours; guaranteed as new; sell for \$40. New 14-inch "National" kerosene burner for above, cost \$25, sell for \$15; alcohol lighter, cost \$5, sell for \$1; Nash fuel pump, cost \$13.50, sell \$9; brass pressure tank for main fire, cost \$2.50, sell \$3; copper pressure tank for pilot

light, cost \$3.50, sell for \$2; gauge for main fire, cost \$3.00; sell for \$1.50; gauge for Pilot light, cost \$3, sell for \$1.50; automatic steam pressure regulator for main fire, cost \$5, sell \$3; first check or money order for \$70 takes above, or will sell separately. R. E. Caldwell, 564 Cabot St., Beverly, Mass.

**TIRES**—We sell any tire on the market; new casings at the following prices: 28x2 1-2, \$9 each; 28x3, \$17 each; 30x3 1-2, \$20 each; 32x4, \$26 each; 34x4, \$27 each; other sizes and tubes in proportion. Chicago Vulcanizing Co., 1463 Michigan Ave., Chicago, Ill.

**TIRES** for automobiles; brand new goods; overstocked: 28x2 1-2, \$8; 28x2, \$14.50; 28x3 1-2, \$14.80; 30x3, \$14; 30x3 1-2, \$16.50; 30x4, \$18.75; 32x4, \$20; write for other sizes; will surprise you. A. H. Kasner, 162 Church St., New York. Largest Tire Dealers in U. S.

**TIRES**—Second-hand tires and tubes always on hand; vulcanizing in all its branches; recovering a specialty; leather non-skid tires recovered and guaranteed to run 2,000 miles; write for price list of repair work. N. Y. Steam Rubber Tire Repair Works, 306 West 52nd St., New York. Phone, 3018 Columbus.

**TWO LIMOUSINE BODIES**—One trimmed with morocco, other may be finished to order. Quinsler & Co., 26 Cambria St., Boston, Mass.

**VAPORIZERS** for sale—For White steam cars; special carbon steel, guaranteed not to choke with carbon, \$15. Webb Jay Motor Company, 2335 State St., Chicago, Ill.

**WANTED**—To hear from every individual automobile owner in the States and Canada, requesting our catalogue; we make and sell mud guard splashers, slip covers, top boots, chain boots, spark plugs, tires and detachable treads, everything for the auto; liberal discounts on orders exceeding five dollars. Jenkins Specialty Mfg. Co., Sumter, S. C.

**Situations Wanted**

**BOOKKEEPER**—Expert for garages, agencies, repair shops, disentangles books for moderate charge; calls few hours each week to post them right; references; French translations. Enaj, 41 West 60th St., New York.

**CHAUFFEUR**—Am 25 years, German; can handle and keep up any car. E. F. Goodman, Union, S. C.

**CHAUFFEUR**—Twenty-four, three years' experience, excellent driver and repairman, desires position, city or country; has traveling experience; speaks French, English and German; first-class references. W. Spencer, General Delivery, Chicago, Ill.

**PARTY** having excellent business ability, best references, wishes position of responsibility with large concern; salary of no consequence until worth has been demonstrated. Address A. L., care The Automobile.

**WANTED**—Position as expert general repairman. E. F. Goodman, Union, S. C.

**Help Wanted**

**AUTOMOBILE INSPECTOR**—One competent to inspect every phase of the highest grade of automobile construction, from the drafting room to the finished product, including road tests. Address C. B. A., care The Automobile.

**SUPERINTENDENTS**, draftsmen, designers, salesmen; positions open in all sections; salaries \$1,200 to \$10,000; write for list. Hangoods, 305 Broadway, New York; or 1012 Hartford Bldg., Chicago, Ill.

**WANTED**—To correspond with expert desirous of locating in the West. Harry R. Farmer Garage, Stillwater, Minn.

**WANTED**—January 1, New York representative, acquainted with the automobile trade, to handle our line of specialties; references required. International Metal Polish Co., Indianapolis, Ind.

**Insurance**

**AUTOMOBILE INSURANCE**—Complete protection at lowest rates. McNear & Wilbur, 34 Pine St., New York City, and Union Bldg., Newark, N. J.

**COMPLETE** automobile protection in one policy; liability, damage to car and to property, burglary, owner and driver's accident insurance. The General Accident, Se-wall & Alden, N. Y. Mgrs., 23 Liberty St., New York City. Policies covering fire and transportation.

**INSURANCE** for automobiles—Broad, safe policies at lowest prices; insurance against fire, self-ignited explosions, transportation hazards, theft, etc.; best service guaranteed, no matter where insurer is located. For particulars, address H. W. Beals, 76 William St., New York City. Phone, 3052 John.

**INSURANCE** for motor cars against every risk, including fire, explosion, self-ignition, theft, collision, accident, transportation, perils and other damages; cars insured anywhere in the world by the kind of "Policies that Protect," at the lowest rates of premiums; automobile ball bonds to cover all States. Demonstrating policies for the trade. Dixie Hines, Times Building, New York City.

**Miscellaneous**

**ATTENTION**, automobilists—Two very fine cinnamon bear robes, cost \$250; I have sold my automobile and I will sell the pair for \$25; they are almost new. See my chauffeur. Dr. Clark, 142 West 37th St., between Broadway and Seventh Ave., New York City.

**AUTOMOBILE DRIVING** taught immediately, reasons afterwards; \$5 a week; particulars from Automobile Sales Corporation, 1661 Broadway, New York, 1,500 new and used cars; all makes; price lists mailed. J. J. Evans, tires and supplies.

**AUTOMOBILE DRIVERS**—Earn \$4 to \$8 a day. Become an automobile engineer, a professional automobile driver, and earn \$4 to \$8 a day; position will be secured for you. My free booklet will tell you how to make success. I send it free. Address President J. J. Evans, 1661 Broadway, New York City.

**CHAUFFEURS**, machinists and repairmen can secure, free, a set of Bullard wrenches; write us for special offer. Bullard Automatic Wrench Co., Providence, R. I.

**DRAFTSMEN**—Thorough and complete course of instruction in automobile design and construction, prepared and conducted by E. Favery. Fundamental elements of design; formulae; applications; latest practice of American and European builders. Information impossible to obtain elsewhere; of greatest benefit to designers, draftsmen, engineers, salesmen and others desiring thorough knowledge of automobile design and construction. Instruction in class-room or by mail. Prospectus on request. New York School of Automobile Engineers, 146 West 56th St., New York.

**EMPIRE TIRE REPAIR CO.**, 1615 Wabash Ave., Chicago. Phone, Calumet 1856. We retread, recover and repair all makes of tires; factory workmen, using factory methods; satisfaction guaranteed.

**FOR SALE**—Fireproof garage building, with lot 40x105; best location in Oakland, Cal.; population, 235,000; \$5,000 will handle this. Address Box O., care The Automobile.

**GARAGE FOR VISITORS**—Situated on direct route of visiting autoists at the upper entrance of Central Park and at intersection of Eighth Ave., Central Park West and 110th St. One block from Seventh Ave., and handy to Amsterdam Ave. and to 110th St. entrance to Riverside Drive. Convenient to any northern approach to Manhattan. Every facility for proper care of cars at lowest possible prices. Near subway and elevated stations to up or downtown. Parkway Garage, 110th St. and Central Park West, New York City.

**GARAGE** and machine shop and a good business for sale; in Monmouth, Ill. "Garage," care The Automobile.

Continued on page 54

**GARAGE TO RENT**—Entrance 24 West 35th St.; building 24x30; second floor; five rooms and bath; rent, \$100; commission to any one furnishing a tenant. William J. Roome, 11 West 34th St., New York City.

**GIVE YOUR 1903 or 1904 Franklin cars** more power; we manufacture mechanical inlets for 1903 and 1904 Franklins; we guarantee them to give satisfaction. Write us for description and information. The Akron Auto Garage Co., Akron, O.

**GOING TO BUILD A GARAGE?**—We make garage architecture a specialty. Hills & Co., 83 Knowls St., East, Cleveland, Ohio.

**LAMPS, rails, brake handles and all parts** of the automobile polished, buffed, nickel or brass plated, at reasonable prices; prompt attention given to orders by mail or express; satisfaction guaranteed. Modern Plating Works, 207 Centre St., New York City.

**MODEL VULCANIZING CO.**—Automobile tire exchange and automobile tire repairing. 1547 Michigan Ave., Chicago, Ill. New and second-hand automobile tires bought and sold; can fit your car with any make or size, and save you money. Phone, Calumet 531, long-distance connections. All repairs guaranteed.

**RENEW old dry batteries;** send 25 cents for tested recipes. R. B. Graham, Stockton, Kansas.

**REO DEALERS and owners**—We make a complete outfit for your 2-carbureter cars, consisting of the famous Breeze carbureter, with all necessary attachments, ready to bolt on; no mechanical work necessary; our experiments show 20 per cent. more power, easy running, and quick starting on a cold morning; complete outfit lists at \$24. Jenkins Specialty Mfg. Co., Sumter, S. C.

**SAVE YOUR TIRES**—Are you going to use your car every day this winter? Will it be standing on the tires for days at a time? Do you want to save your tires? Take the car's weight from them with Garlick's Auto-Props; strong, durable, cheap; set of four sent by express, any address, on receipt of \$2.50; with jack attachment, \$4.00. Garlick Auto Prop Co., Paterson, N. J.

**TIRES REPAIRED**—Automobile owners, do you want your tires repaired or recovered by people who know how? Give us a trial and be convinced. Inner tubes vulcanized at short notice. Jungking & Vogler, 158 Chambers St., New York City. Telephone, 3386 Cortlandt.

**TWO SILVER GRAY fox fur auto robes** for sale; 12 skins and tails on each robe. J. H. Young, 26 West 65th St., Phone, 6719 Columbus, New York City.

**WANTED**—Place to start automobile garage, by party of six years' experience; would consider partnership with right party. Address "Business," care The Automobile.

**817 MEN** who enrolled in our automobile school last season say their time and money were well invested. Our courses are thorough and practical. We have a large garage, completely equipped, and expert instructors. The school is not run to make money, but to give men a thorough course of instruction at a minimum cost. Catalog sent on request. West Side Y. M. C. A., 310 West 57th St., New York City.

**Wind Shields \$12**

Neat and durable. Cannot be cut with glass when in a collision.

Runabout Tops \$16.00 and \$18.00.

Complete Curtains and Rail.

Guaranteed to fit Ford, Maxwell and Olds. Description on application. Chicago Auto Top Co., 80 W. Jackson Boulevard, Chicago.

**The Automobile Handbook**

A practical book for owners, operators, and mechanics. Includes road troubles, motor difficulties and other contingencies and how to handle them. By L. ELIOTT BROOKS. 320 pages. Numerous illustrations. Full leather, limp. Price, \$1.50. Address The Automobile, Flatiron Building, New York.

SUBSCRIBE FOR THE AUTOMOBILE

**M & M CEMENT**  
And Acid Cure Solution



will enable you to make your own tire repairs and at the minimum of expense and bother. It's a cold cure process—no cumbersome apparatus required—and is instantaneous and positive. No matter what kind of repair is necessary, use the genuine—M & M Cement—and you will get the maximum in tire efficiency.

For Sale by All Dealers and Jobbers.

DISTRIBUTORS:

Post & Lester Co. Hartford, Conn.  
Excelsior Supply Co., 233 Randolph St., Chicago, Ill.  
Chanslor & Lyon Motor Supply Co., San Francisco, Cal.  
Coughlin & Davis, Eighth and Walnut Sts., Cincinnati, Ohio.  
Auto Light & Motor Supply Co., Philadelphia, Pa.

**M & M MFG. CO., Akron, Ohio**

**BOSTON**

**ACME** \*G.R.  
BOSTON MOTOR CO.  
Phone, Tremont 2. 44 COLUMBUS AVE.

**APPERSON** \*G.R.  
GEORGE M. BROWN  
Phone, Oz 1934-1 6 COLUMBUS AVE.

**JACKSON**  
E. P. BLAKE CO.  
Phone, 767 Hay. 15-23 Hawkins St. and Motor Mart

**NEW ENGLAND**

**JACKSON**  
E. P. BLAKE CO.  
15-23 Hawkins St., and Motor Mart  
Phone, 767 Hay. BOSTON, MASS.

**NEW JERSEY**

**JACKSON**  
ESSEX AUTOMOBILE CO.  
Phone. 9-11-13 LOMBARD ST., NEWARK

**CHICAGO**

**JACKSON** \*G.R.  
RALPH TEMPLE AUTO CO.  
Phone, Harrison 2933. 308 MICHIGAN AVE.

\*NOTE—Letters in upper right hand corner of each card indicate as follows: G—Garage or storage facilities; E—Equipped to charge electric vehicles; R—Repair shop.

**HIT HARD**  
*you can't break it.*  
WE KNOW HOW TO MAKE THEM  
**TOUGH.**  
**DROP FORGINGS**  
The Wyman & Gordon Co.  
WORCESTER, MASS. CLEVELAND, OHIO.



"The Car without a fault"

**THE MARTINI**  
Made in Switzerland. Built to climb mountains.  
Reliable, Fast, Noiseless

Send for handsome illustrated 1907 Catalogue FREE

**MARTINI IMPORT CO., 239 West 50th St., New York**

**Turned and Screw Work**  
of every description for Auto Use, from 1-in. dia. down

QUICK DELIVERIES

**GEO. W. DOVER CO.**  
80 Clifford St. (Automatic Dept.) PROVIDENCE, R. I.



Many 1908 cars will carry the famous B. & S. Auto Wrench, will yours? It is a reliable companion for old or new. Ask for our catalog of Auto Tools and Forgings.

**The Billings & Spencer Co., Hartford, Conn.**



**OUTFITS AND SUPPLIES**

**C A T A L O G**

**AUTOMOBILE TRIMMINGS MOUNTINGS**

LARGEST AND MOST COMPLETE LINE IN AMERICA  
Mailed you on request

**C. COWLES & CO., New Haven, Conn.**

**HIGH-GRADE Pressure Gages**

FOR Gasoline, Air, Water or Steam  
ALSO Pop Valves, Water Gages and Cocks



**THE ASHTON VALVE CO., 271 Franklin St., Boston, Mass.**

**STOP**

Hand Pumping. Attach our **HILL CLIMBING PUMP** on your '03-'04 White Steamer.  
Sent Complete—Easily Attached.



242 Freeport St. **EDW. S. CLARK**  
Boston, Mass.

**EXPANDED METAL LOCKERS**

Sheet Steel Material Closets

**MERRITT & CO.**

1045 Ridge Ave. **PHILADELPHIA, PA.**

**NEVER CONTRAICTED**

THE CLAIM THAT "**GLOBE**" METAL POLISH IS THE BEST POLISH OBTAINABLE TO-DAY. WHY BOTHER EXPERIMENTING WITH OTHER BRANDS?

**RAIMES & CO., 50 FERRY ST., NEW YORK**

**Famous NEWPORT SPARK PLUG** That Suits Don't Soot

Satisfaction guaranteed. Made in all standard sizes 1/2" pipe. Metric 1/2 x 1 1/8. Stands up and does the work.



**THE EDGAR MANUFACTURING CO.**  
104 Hanover Street Boston, Mass.  
*Electros ready, jobbers' catalog!*

**P. W. OFELDT & SONS**  
Nyack-on-the-Hudson, N. Y.  
Manufacturers of

Blue Flame Kerosene Burner  
Safety Water Tube Boiler  
Automatic Water Regulator  
Automatic Fuel Regulator  
Feed Water Heater  
Compound Steam Engines  
Our Kerosene Burner works to perfection on White Steamers



**Soap News**

Interesting dirt problems do not seem difficult when "Ericka" Hand Soap is used. Genuine bears green label and is registered.



**SPRINGFIELD MASS.**

At all Auto Stations

**IMMEDIATE DELIVERIES**

**Sliding Gear Transmissions**

SUITABLE FOR 20-24 H. P. CAR

**WE CAN FILL ORDERS FOR ONE OR ONE HUNDRED PROMPTLY**

**ECLIPSE MACHINE CO., ELMINA, N.Y.**

**Best for Ignition.**

WE ALSO MAKE AND SELL

"Something Electrical for Everybody."

Send for Catalog J-22.

**MANHATTAN ELECTRICAL SUPPLY CO.,**  
New York: 17 Park Place. Chicago: 188 Fifth Ave.



**BALDWIN CHAIN & MFG. CO.**

—MAKERS OF—

**AUTOMOBILE CHAINS and SPROCKETS**

**WORCESTER, MASS.**

NO PUNCTURES NO BLOWOUTS

**USE THE SHAW**

**Self-Sealing Inner Tube**

Write for Circular

**AUTOMOBILE UTILITIES CO.**

Motor Mart, Boston, Mass.

**CULLMAN SPROCKETS**

and Differentials in stock and to order also. Baldwin, Diamond and Whitney Chain.

Send for new Catalog.

**Cullman Wheel Co.**  
1027 Dunning St., Chicago



**BOILERS**

FOR STANLEY STEAM CARS

Also Grout, Prescott, Locomobile and Mobile Boilers, all guaranteed to fit plated steel tubes. Special boilers 1 to 60 H.P.; repair work. Write Steam Carriage Boiler Co., Oswego, N. Y.

**"E.&J." Lamps**

Gas and Oil Side-lights.

Our 1908 Catalogue mailed on request.

**The Edmunds & Jones Mfg. Co.**  
DETROIT, MICH

**AIR VALVES**

Our style "A" covers are used for this purpose. Are they oil tight and dust proof?

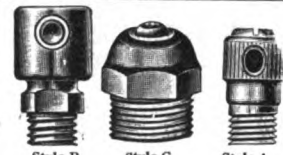

Style B Style C Style A

**C. F. TUCKER, Hartford, Conn.**

**HARD TIMES WON'T STRIKE YOUR CAR**

IF YOU USE **AUTO-SHINE**

Gives an air of prosperity to the car and its owner. Restores the lustre to the varnish and insures long life to the cushions and top. **WON'T COLLECT DUST.**

4-oz. trial bottle, postpaid, 35c.

**The Auto-Shine Co., P.O. Box 94, Buffalo, N. Y.**



**Rotary Pumps**

for Circulation of Water and Oil on Automobile, Marine or Stationary Engines, and for bilge purposes. All sizes and capacities.

Send for Catalogue.

**The LIPMAN MFG. CO.** 210 Pleasant Street, Beloit, Wis.

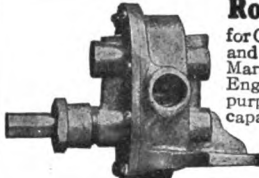

**AUTO SUPPLIES**

Catalogue Free

Just say "Send me No. 37" and you will receive free a big book of illustrations with description and low prices on all kinds of sundries for all kinds of cars.

**New York Sporting Goods Co.,**  
17 Warren Street, New York.



**The P. T. C. Power Tire Pump**

No labor—no trouble—start the pump, watch the gauge and stop when proper pressure is attained. Write for full particulars.

**THE PACIFIC TUCKING & MFG. CO.,**  
471-473 18th Street, Brooklyn, N. Y.

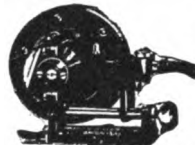

**METAL POLISH**

Highest Award  
Chicago World's Fair, 1893.  
Louisiana Purchase Exposition  
St. Louis, Mo., 1904.

3-oz. Box for 10 cents.  
Sold by Agents and Dealers all over the world. Ask or write for FREE samples.

5-lb. Pails, \$1.00.  
**GEO. W. MOFFMAN**  
Expert Polish Maker.  
Indianapolis, Indiana.  
Sold by Dealers.  
New York City Office, 1-3 Park Row



**LOOK BATTERIES AND BELL PUMPS**

**Franco-American Auto & Supply Co.**

**SOLE AGENTS**

**Desk K, 1404 Michigan Avenue**  
**CHICAGO**

**THE SPENCER Power Air Pump**

1908 Model

It is carried in the tool box

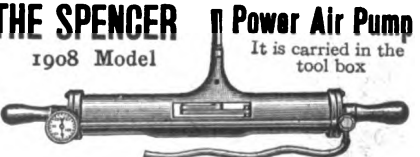

**THE AUTO PUMP COMPANY**  
Write for circular 14 Main St., SPRINGVILLE, N.Y.



**"THE REEVES" Auto Engines** Air and Water Cooled  
**THREE MODELS FOR EARLY DELIVERY**  
 Model E, 4x4, 4 cylinder, 20 H.P., air cooled.  
 Model L, 4x4, 4 cylinder, 22-24 H.P., water cooled.  
 Model N, 4x4, 2 cylinder opposed, 10 H.P., air cooled.  
 Write for particulars to  
**REEVES PULLEY COMPANY**  
 Columbus, Indiana

**ANNOUNCEMENT**  
 "Standard Alloy Steel Balls" made of alloy steel will be ready for delivery by or before June 1st.  
 Double Crushing Strength Ordinary Balls. 3-4 inch crucible steel balls, crushing strength, 50,000 to 56,000 lbs. 3-4 inch "Standard Alloy" Steel balls, 95,000 to 100,000 lbs. Guaranteed true to .0001 inch in diameter and sphericity.  
 PRICES QUOTED ON REQUEST  
**STANDARD ROLLER BEARING COMPANY**  
 Cor. 50th St. and Lancaster Ave., Philadelphia

**THE LUCKY MAN**  
 Guides himself with the Sensitive Hand of the  
**Index Speed Indicator**  
*Why don't you enjoy the charm of its influence?*  
**Index Speed Indicator Co., Minneapolis, Minn.**  
 FORMERLY OLIVER INSTRUMENT CO.

**CANDY CARBIDE**  
 For French Auto Lamps (Impregnation dans le vide)  
 Packed only in 10 lb. cans. Price, \$2 each  
 Discount to Dealers in case lot of 12 cans  
 —SOLE MANUFACTURERS—  
**ACETYLENE GAS ILLUMINATING CO.**  
 105 Walker Street, New York

**SALISBURY WHEEL & MFG. CO.**  
 EXCLUSIVE MANUFACTURERS OF  
**Automobile Wheels and Axles**  
**JAMESTOWN, N. Y.**

**AUTOMOBILE SUPPLIES**  
 AT LOWEST PRICES  
 Get our Illustrated Catalogue and save time, trouble and money  
**MANHATTAN STORAGE CO.**  
 1611 Broadway, New York



Test your batteries with a meter that is accurate, durable and guaranteed.  
**ROBERT VOLT-AMMETERS, \$6.00**  
**" VOLT-METERS, \$4.00**  
**AMMETERS, \$4.00**  
 including leather case  
 SEND FOR CATALOG  
**ROBERT INSTRUMENT CO.**  
 66 Shelby St. Detroit, Mich.

**COMPLETE COURSE**  
**Automobile Instruction**  
 Invaluable to the owner or prospective owner of a motor car.  
**Practical and to the Point**  
 Send for Prospectus to the  
**Correspondence School of Motor Car Practice, Tarrytown, N. Y.**

**SUPPLIES**  
 OF EVERY DESCRIPTION FOR  
 AUTOMOBILE AND MOTORIST  
 Send for Illustrated Catalog and Price List  
**JAS. L. GIBNEY & BRO.**  
 211-213 N. Broad St., PHILADELPHIA, PA.

Not a mere spark plug—but the greatest achievement ever made in spark plug construction. A spark plug fully in keeping with the highest grade motors in appearance, durability and service.  
**PRICE, \$2.00**  
 Metric or Half Inch  
 Ask your dealer or write for information.  
**T. C. & W. L. FRY CO.**  
 808 Chestnut St., Rochester, Penn.

**1908 Catalogue**  
 OF  
**Automobile Supplies**  
 3961 Olive St., St. Louis, Mo., U.S.A.  
**Behen-Faught Motor Car Equipment Co.**

Automatic  

**The "NATIONAL"**  
 GIVES A PERFECT COMBUSTIBLE MIXTURE OF GASOLINE AND AIR AT ALL TIMES regardless of Engine speed, condition of atmosphere or whether run on low throttle or wide open.  
 The National Auto Accessory Co.  
 Office 84 State St., Boston  
 Factory at Merrimac, Mass.  
 For 1908

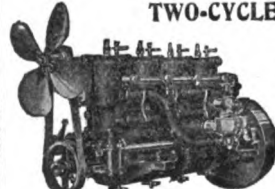
**TWO-CYCLE AUTOMOBILE MOTORS**  

 The kind that Roberts builds. 5 to 60 h.p.  
**Roberts Motor Co.**  
 Box 113, Clyde, O.

**Avoid Accidents**  
 BY USING  
**The RAYMOND BRAKE**  
**ROYAL EQUIPMENT CO.**  
 155 Housatonic Ave. Bridgeport, Conn.

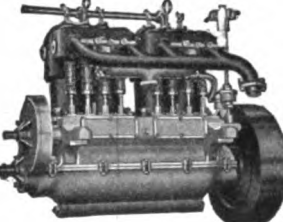

**BEAVER MOTORS**  
 Vertical 4-Cylinder—4 1/2 x 4 1/2  
 Horizontal Opposed—4 1/2 x 4 and 5 1/2 x 4 1/2  
**Beaver Mfg. Co.**  
 237 Oregon Street Milwaukee, Wis.



**Best for Automobiles and Motor Boats**  
**Pantasote**  
**LEATHER**  
**THE PANTASOTE CO., New York and Chicago**

*Put a Splldort Coil on your car and see what a difference it will make in your faulty ignition.*

**OUR 1907 MODEL TIMER**  
**"THE QUAD"**  
 It has no equal  
 Try one and be convinced  
**THE QUAD MFG. CO.**  
 SOUTH SCIOTO ST.  
 COLUMBUS, OHIO, U. S. A.  
 Sole Manufacturers and Distributors



**The Caterpillar Flame**  
 is not a thin blue spark. The PFANSTIEHL COILS need no "adjusting." A long life to your battery and contact points. Proof against break down on any voltage. Guaranteed to increase the power of your car. Every unit an X-Ray Coil.  
**PFANSTIEHL ELECTRICAL LABORATORY, North Chicago, Ill.**

**METEOR WIRE FOR SPARKING POINTS**  
 Gives a continuous uninterrupted spark. Will not corrode and will not wear off. See that it is in your SPARK PLUG.  
**HERMANN BOKER & CO.** 101-103 Duane Street NEW YORK CITY, N.Y.

**Positive Lubrication Assured**  
 We make anything you want in a Mechanical Oilier. Our Oiliers excel all others both in price and service. Let us prove it. Sent on approval to Auto and Motor Boat manufacturers. Write us before ordering elsewhere.  
**STANDARD AUTOMATIC LUBRICATOR CO.**  
 371-373 Ellicott St., Buffalo, N. Y.

**HARTFORD JOINTS**  
 Pronounced by Eminent Engineers to be the most satisfactory universal joint on the market. Write for circulars, they tell you why.  
**HARTFORD AUTO PARTS CO.,** 438 Asylum Street Hartford, Conn.  
 J. S. BRITS Co., U. S. Distributors, Times Bldg., N. Y.





**HESS-BRIGHT**  
**BALL BEARINGS** DWF  
 AMERICAN 19th AND HAMILTON STS. EUROPEAN  
 PHILADELPHIA, PA

**Hotchkiss**  
**ANTI-JOLT**  
 Makes Rough Roads Smooth  
 Hotchkiss Mfg. Co., 1262 Michigan Ave., Chicago

**LAVIGNE OILERS**  
 Force Feed, with Micrometer Adjustment.  
 Positive, Reliable, Durable. Without Springs or Balls.  
 Used exclusively by 27 automobile manufacturers.  
 Specially designed oilers for Ford, Maxwell  
 and Cadillac Runabouts.  
 Send for descriptive catalogue "A"  
**LAVIGNE MFG. CO., Detroit, Mich.**

**PEUGEOT**  
 FRANCE  
**Peugeot Chains—"Strongest in the World."**  
**296 Broadway, New York**

**PARISH & BINGHAM**  
 PRESSED STEEL  
**FRAMES**  
 ARE STANDARD  
 WRITE FOR ESTIMATES  
 CLEVELAND, OHIO

**BARRETT AUTO JACKS**  
 "The Jack that Duff Builds"  
 The buyer will never have cause to complain  
 and the seller will gain the buyer's confidence  
 when a Barret Jack changes hands.  
**THE DUFF MANUFACTURING COMPANY**  
 Exclusive makers of "Barrett" Jacks  
 Works: Allegheny, Pa. Pittsburgh, Pa.  
 26 Cortlandt St., New York  
 4 Rue Auber, Paris 124 Longacre, London  
 Antwerp Montreal

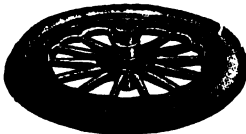
  
 Let us figure with you on artillery and  
 steel rim wheels, hubs, steering  
 knuckles, nickel steel cap screws,  
 special screw machine parts, etc.  
 Our catalogue is ready. Ask for copy.  
**JAMESVILLE MFG. CO., Jamesville, N. Y.**

**THE MOSLER**  
**Spit Fire Spark**  
**Plugs**  
**Are the Best**  
 A. R. MOSLER & CO.  
 163 West 29th Street - New York City

**MIDGLEY**  
**Steel Automobile Wheels**  
 and  
**Pressed Steel Products**  
 Write for full information  
**Midgley Mfg. Co., Columbus, O.**

**QURIDE**  
 (REGISTERED)  
**FILLED GEARS**  
**ARE SILENT RUNNING**  
 Let us tell you more about "QURIDE"  
**Picrome Hide Co., Syracuse, N. Y.**

**Automobile Gears**  
 Mechanically perfect.  
 Prompt deliveries.  
*If in a hurry, wire us.*  
**R. D. NUTTALL COMPANY**  
**PITTSBURG, PA.**

**Special Drop Forgings in Quantities**  
**Chrome Nickel and all Special Steels**  
**Oil Treating and Annealing**  
 The Canton Drop Forging and Mfg. Co.  
 CANTON, O., U. S. A.

**DROP FORGINGS**  
 Of every character, also Steam Hammer  
 Crank-Shaft Forgings—Rough Slotted,  
 Rough Turned, or Completely Finished.  
 SEND BLUE PRINTS FOR ESTIMATES  
**ANDERSON FORGE & MACHINE CO.**  
 18 ST. AUBIN AVE., DETROIT, MICH.

**The Perfection Spring Co.**  
**AUTOMOBILE SPRING SPECIALISTS**  
  
 High Grade Springs of Every Type  
 See our exhibit at both New York Shows  
 2413 Superior Ave., N.W., CLEVELAND, OHIO

**COOLERS** **FENDERS**  
  
**BRISCOE MFG. CO.**  
 DETROIT, MICH. U.S.A.  
**HOODS** **TANKS**  
 EASTERN FACTORY, NEWARK, N. J.

**THE MAYO RADIATOR CO.**  
**HIGH**  
**GRADE**  
 NEW HAVEN, CONN.

**EISEMANN-LAVALLETTE**  
**HIGH-TENSION MAGNETOS**  
**LAVALLETTE & CO.,**  
 112 West 42d St., New York

  
**The Springfield No. 2—Ratchet Screw**  
 For cars weighing from 1,000 to 4,000 pounds.  
 Height, 12 inches. Rise of screw, 7 inches. The  
 base is made of malleable iron, heavily ribbed and  
 dust-proof. The ratchet works in ground-tight en-  
 gaging, from which both ratchet and screw are lubri-  
 cated: one filling of grease being sufficient for a sea-  
 son. The ratchet pawl is made of steel and hard-  
 ened. When this Jack is not in use it is in a most  
 compact form, all parts being locked together, and  
 is absolutely rattle-proof. Weight 5 pounds.  
 Price \$4.00, net.  
**The Shaver Company, Springfield, O., U.S.A.**

**ALUMINUM**  
**BRASS AND BRONZE**  
**AUTOMOBILE CASTINGS**  
 Satisfaction Guaranteed  
**American Brass and Aluminum Works**  
 Indianapolis, Ind.

**ROSS GEAR & TOOL CO.**  
 LAFAYETTE, IND.  
 Manufacturers of  
**New Tubular Steering Gear and**  
**Bevel Gears for Cambered**  
**Rear Axles**

**ALUMINUM**  
 PHOSPHOR BRONZE and BRASS  
**CASTINGS**  
 FOR AUTOMOBILE WORK  
**PIONEER BRASS WKS., INDIANAPOLIS, IND.**

**"Kinwood Radiators"**  
 Force Feed Oilers, Pressed Steel  
 Dashes, Pressed Steel Frames,  
 Hoods, Mufflers, Fenders, Step  
 Molding.  
**KIRSEY MFG. CO., No. 1126 E. 3d St., DAYTON, OHIO**

**Spicer Universal Joints**  
 Dust Proof—Oil Tight  
**Ryder Spark Generator**  
 No Batteries, Spark Coils or Moving Wires  
 or Contacts of any sort.  
**K. F. PETERSON, 166 Lake St., Chicago.**  
**Spicer Universal Joint Mfg. Co.**  
 7 Madison Avenue Plainfield, N. J.

**Auto-Parts to Blue Print**  
 ACCURATELY—SATISFACTION  
**Difficult Stamping and Drawing**  
**OTTO KONIGSLOW MFG. CO.**  
 CLEVELAND, OHIO



**Auto-Top Fabrics**  
OF EVERY DESCRIPTION  
Samples and Price List on request  
**L. J. MUTTY CO., Boston**

**Myers Perfect Fitting Tops** Tops of Known Quality—Tops with a Reputation Behind Them  
Send for Samples of Materials and New Catalogue  
**MYERS AUTO TOP CO., Dayton, O.**  
Automobile Tops of Every Description  
Get our prices on Tire Covers

**LASCO FOLDING GLASS FRONT**  
Simple, effective, correctly designed mahogany finish wood frame—trimmed in brass—3/16 crystal plates—steel stay rods—bottom of frame shaped to dash of any standard automobile—can be attached easily and quickly. We make the London Tops. Write for details and prices.  
**London Auto Supply Co., 1221 Michigan Ave. CHICAGO**

**"THERE IS A REASON"**  
Why "King" Tops represent Quality. A postal will bring you samples and quotations you cannot afford to miss.  
**KING TOP MFG. CO., Dayton, Ohio**



Let us send you a **DUPLEX COIL** to use on your car 30 days free in place of your present coil. If the Duplex Coil doesn't cure 90% of your engine troubles, send it back collect, and replace your old coil. Write on your business stationery, giving name of car, number of cylinders, and any good reference and we'll send you a Duplex Coil by first express. Address  
**Station N. Duplex Coil Co., Fond du Lac, Wis.**

**ALUMINUM BODIES**  
**J. M. QUINBY & CO.**  
Est. 1834.  
**NEWARK, N. J.**  
Carriage Builders

**High Grade Auto Tops Our Specialty**  
Also Slip Covers, Lamp Covers, Tire Covers, Tool Cases, Dust Hoods and Foot-rests.  
Write for Catalogue and Prices  
**WARNER Pole & Top Co.**  
1652 Central Ave., CINCINNATI, OHIO



**TOPS MADE FROM BEST MATERIAL** of Our Own Manufacture Which We Guarantee Perfect.  
**AUTO TOPS**  
All Styles for All Makes. Spray Hoods for Motor Boats.  
**CHARLES P. McCLELLAN**  
Fall River, Mass.

**Blasier Tops and Fronts**  
For the best and most practical. Exclusive Blasier features and quality.  
Write for Catalog and price list.  
**M. E. Blasier Mfg. Co., 69 Columbia St., Utica, N. Y.**



**AUTOMOBILE TOPS**  
\$14.00 AND UPWARDS  
Write for Catalogue and Prices  
**BUOB & SCHEU**  
Court and Spring Streets Cincinnati, Ohio



**THE BEST SPARK PLUG**



**BOUGIE MERCEDES**  
LEADS THE WORLD BECAUSE  
It is absolutely proof against oil or soot—absolutely self-cleaning. It has an insulation of double stone—Guaranteed never to crack. It is the fastest plug made. It has no packing in the heat. The only plug suitable for high-tension ignition. We guarantee it for one year.

LARGEST STOCK OF  
**Asbestos-Copper Gaskets**  
In America. Over 600 sizes in stock.  
**HERZ & CO.**  
CIVIL ENGINEERS  
203 Lafayette St. NEW YORK  
Write for our new "Gold Book"—free—a catalog and reference book combined.

**PIRELLI**  
That Wonderful Italian Tire  
296 BROADWAY, NEW YORK



**AUTO BODIES**  
Best equipped factory in Boston for Motor Car overhauling, painting and repairing. Can repair or make new any part.  
**D. P. NICHOLS & CO.**  
121 West Brookline St., BOSTON, MASS.

**THE HOFFECKER**  
Stands for the BEST in Speedometers. Positively the HIGHEST GRADE and, quality considered, the CHEAPEST. Unrestricted guarantee with every one. Inspection invited. Looks the best—Made the best—Operates the best.  
**THE HOFFECKER COMPANY**  
Motor Mart, Park Sq., Boston, Mass.

The Oldest Manufacturers of Bow Sockets in the World  
**ASHTABULA**  
Bow Socket Company  
Ashtabula Ohio



**Radium Decarbonizer**  
chemically removes carbon from cylinders, piston valves and rings  
Increases Power 20 Per Cent. Volatilizes carbon, in which form it passes out exhaust. Injury to metal work impossible. Agents wanted in certain localities. Write to-day for particulars.  
**GENERAL ACCUMULATOR & BATTERY CO., 150 2d St., Milwaukee, Wis.**

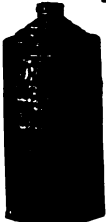

**RICH ALL SIZES SPARK**  
\$1.00 BY MAIL \$1.00 BY MAIL  
**RICHARDSON ENGINEERING CO HARTFORD, CONN.**



**THE 3 BEST**  
Divided  
**Windshields**  
**VOLTZ BEECHER SCHILDBACK**  
A shield for everyone Write for prices  
**Limousine Carriage Mfg. Co.**  
3511 Michigan Av., Chicago

**The New Motz Non-Skid Cushion Tire**  
Fits Universal and Standard Clincher rims. We furnish a tool for applying. Send for circular J  
**The Motz Clincher Tire & Rubber Co.**  
Akron, Ohio



**"THE CAR THAT CONTINUES TO MAKE GOOD"**

*Acme*

ACME MOTOR CAR COMPANY, Reading, Pa.

The Greatest Value Ever Offered

**F** \$1750

4 Cylinder 30 H. P. Motor

CORNISH-FRIEDBERG MOTOR CAR CO.

1233 Michigan Avenue CHICAGO

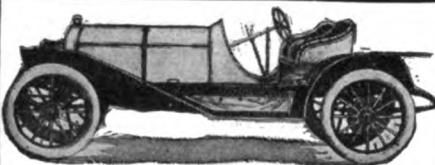

Assemble your 6 cylinder car. Write for circular.

HOWARD MOTOR WORKS, Yonkers, N. Y.

**ADAMS - FARWELL**

\$3,250

with top and two extra seats \$3,500

The Car With Revolving Air-Cooled Motor

**THE ADAMS CO.,**

Foot of Third Street, DUBUQUE, IOWA

**THE CAR De Luxe**

A SUPERB LINE OF CARS—

**The JACKSON**

"No Sand too Deep—No Hill too Steep"

2 Cyl. and 4 Cyl.

Runabouts, Roadsters, Touring Cars

15 H. P., 24 H. P., 35 H. P.

Prices \$850, \$1,250, \$1,500, \$2,000

Jackson Automobile Co., Jackson, Mich.

*Aerocar*

4-cylinder, 20 horsepower, 4 passenger, 104-inch wheelbase, \$1,500. Greatest value ever offered. Write.

**AEROCAR MOTOR CO.,**

Detroit, Mich.

1908

**DORRIS CARS**

Dorris Motor Car Co.

ST. LOUIS, MO.

**LOGAN 1908** Model R, Four Cylinder Delivery Wagon

A car equipped with a four-cylinder 20 H.P. motor fitted for rapid work and for day in and day out service; the commercial car which attracted wide attention at the New York Show. For detailed description address

**The Logan Construction Company**

Chillicothe, Ohio

**AUBURN**

1908 5-PASSENGER TOURING CAR \$1,350

"The Most for the Money" in Size, Style, Power and Service. 100-in. Wheel Base. Pressed Steel Frame. 32-in. Wheels. 5 1/2 x 5 double opposed Motor. 24 H. P.

**AUBURN AUTOMOBILE COMPANY**

Auburn, Ind.

Induction Coils

Gives easily understood explanations of the operation of coils. Of great value to the autoist. By H. S. NORRIE. 265 pages. Numerous illustrations. Cloth bound. Price, \$1.00. Address The Automobile, Flatiron Building, New York.

**THE MARMON**

"A Mechanical Masterpiece"

For catalog, address Dept. 12

**Nordyke & Marmon Co.,**

(Estab. 1851) Indianapolis, Ind.

**This Little Space**

is intended to serve as a reminder of

**BAKER ELECTRICS**

the electric carriage of distinctive merit and remarkable quality. Made in the largest and best equipped electric automobile factory in the world. Write for Catalogue.

**THE BAKER MOTOR VEHICLE CO.**

20 80th St., N. W. Cleveland, O.

**FRAYER MILLER**

The Car of Endurance

Cooled Through Air Jackets. AN AMERICAN PRODUCT. Imitating No Foreign Car.

**Oscar Lear Automobile Co.**

COLUMBUS, OHIO

**5-passenger Touring Car**

24 H. P. 5 x 7 motor 104-inch wheel base 3 1/2 x 3 1/2 tires

Write for advance catalogue No. 10

**MODEL AUTOMOBILE CO., PERU, IND.**

**THE LAMBERT 18**

"FRICTION FLYER"

**\$800**

Write for catalogue describing our full line

**THE BUCKEYE MFG. CO.**

Anderson, Ind.

TAKE THE DUST OUT OF YOUR EYES

BY USING

**THOMPSON'S EYEWATER**

ALL DRUGGISTS

**'08 Moline '08**

3 MODELS

Write for catalogue

**Moline Automobile Co.**

EAST MOLINE, ILL.

Just as Good as a

**CADILLAC**

That's the comparison made by salesmen for other cars.

**WHY?**

*Grout*

Gasoline Cars

CATALOG READY

**GROUT BROS. AUTOMOBILE CO.**

Orange, Mass.

**GOLD FACTS served without HOT AIR**

The **BULLARD** Speedometer has ALL the good points advertised by others and some peculiar to itself. We are proving it every day, let us prove it to you.

If you can find a better Speedometer, buy it.

**J. H. BULLARD**

Speedometers and Speed-recorders

HIGHLAND STATION, SPRINGFIELD, MASS.

'08 2-Passenger Light Touring Car.

*Cameron*

Three Forward Speeds and Reverse.

'08 Catalogue ready

**CAMERON CAR CO., Brockton, Mass.**

**Moon Cars**

IF YOU HAVE NOT SENT FOR OUR CATALOGUE DESCRIBING OUR WONDERFUL LINE, WRITE ME AT ONCE

**JOS. W. MOON, Pres., ST. LOUIS**

**Hatfield "Buggyabout"**

The buggy type Automobile of the future

**HATFIELD MOTOR VEHICLE CO.**

MIAMISBURG, OHIO



**OLDSMOBILE**  
 You see them wherever you go  
 They go wherever you see them  
**OLDS MOTOR WORKS**  
 Lansing, Mich.  
 MEMBER A.L.A.M.

Manufacturer to Consumer  
**1907 CAR**  
 30 H. P., Price, \$1,850  
 SEND FOR CATALOGUE  
**TREBERT GAS ENGINE CO.**  
 35 FORD STREET ROCHESTER, N. Y.

*Traveler*  
 TRADE MARK



**CAN YOU BE CERTAIN YOU HAVE PICKED THE BEST CAR BEFORE YOU HAVE INVESTIGATED THIS ONE**  
 You don't purchase a car to-day and another to-morrow. So why not be certain that you have the best before you make your final decision.  
 The 1908 Model is the peer of any car of equal price. We don't expect to sell you a "Traveler" merely on this statement, but we do hope it will so arouse your curiosity that you will write for the proof. Do this now—to-day—before you place your order. Simply dictate the request—it is but a moment's work and later you will agree it was a moment well spent.  
**BELLEFONTAINE AUTOMOBILE CO.**  
 BELLEFONTAINE, OHIO

**"The Best in Motor Cars"**  
**Palmer & Singer Mfg. Co.**  
 1619 Broadway, N. Y.

**COMPLETE WITH TOP**  
*Wayne* \$2500  
**NOTHING TO BUY BUT A LICENSE**

BUILT TO USE  
**Pennsylvania**  
 35 H.P. \$2,800  
**PENNSYLVANIA AUTO MOTOR CO.**  
 BRYN MAWR, PA.

*Add-Wear*  
 Attached and Detached Treads  
 Add-Wear Tire Sleeves  
**ADD-WEAR AUTO TIRE SLEEVE CO.**  
 N. ATTLEBORO, MASS.

**PIERCE-RACINE**  
 1908 MODELS  
 40 H. P., 4 Cyl. Model D, \$3,000  
 30 H. P., 4 Cyl. Model E, \$2,000  
**PIERCE ENGINE CO., Racine Wis.**

**AJAX WRAPPED TIRES**  
 TREAD  
 GUARANTEED FOR  
 5,000 MILES RIDING  
 Write for copy of Guarantee. Dept. C  
**AJAX-GRIEB RUBBER CO.**  
 General Office, 57th St. and Broadway, New York  
 Agents in all large cities.

*Rainier*  
**"The Pullman of Motor Cars"**  
 1908 Models  
 Ready  
 for delivery  
**RAINIER MOTOR CAR CO.**  
 Broadway, corner 50th Street, New York

**Pullman Automobiles**  
 Not only the best for the price,  
 but the best at any price.  
**YORK MOTOR CAR CO.**  
 Manufacturers YORK, PA.

**Diamond**  
**Tires are the best**  
**THE DIAMOND RUBBER CO.**  
 AKRON, OHIO

**REO** the practical motor-car  
 Made by a practical man, and does practical work. Write for book that tells why.  
**R. M. OWEN & Co., Lansing, Mich.**  
 General Sales Agents for the REO Motor Car Co.

*Firestone*  
**SIDE-WIRE SOLID MOTOR TIRES**  
 THE WORLD'S STANDARD  
**FIRESTONE TIRE & RUBBER CO**  
 Akron, Ohio

**DEALERS !!!**  
 This is especially for YOU!

**EASY SALES HANDSOME PROFITS**  
 Nothing will yield better or more profitable results than the "CONTINENTAL" ROADSTER Agency. No car in the market equals the "CONTINENTAL" in any one of the points that compels business—QUALITY, DESIGN, MODERATION of PRICE, and LASTING GUARANTEE. Everything of the latest and best contributing to the motorist's comfort and desires is represented in the "CONTINENTAL" car. Moreover, profits are substantial and "CONTINENTAL" cars superiority is so pronounced that sales are easy—which means a healthy growth of your business—otherwise SUCCESS.



**"CONTINENTAL" ROADSTER**  
 Price, \$900  
 The greatest value in the automobile world for the money. Write for full particulars to-day.  
**CONTINENTAL MOTOR CAR CO.**  
 209-217 Robey St. Chicago, Ill.

*The Stearns* SEND FOR CATALOG  
**F. B. Stearns Co.**  
 2970 Euclid Avenue,  
 CLEVELAND, OHIO. 30-60 horse-power



**Expert Tire Repairing**  
 IN LARGEST TIRE FACTORY  
 IN NEW YORK CITY  
 TIRES CALLED FOR AND DELIVERED  
**Healy Leather Tire Co.**  
 1906 BROADWAY, 90 GOLD ST., NEW YORK

**\$250 Original Motor Buggy**  
**\$400 for 12 H.P. Top \$25 extra**  
 Over 400 in use. Invented by an engineer after 10 yrs. labor in auto work. Speed 4 to 40 miles per hour. 50 to 100 miles on one gallon of gasoline. Will climb steep hills and run in mud and sand. Guaranteed for one year. Write for catalogue, testimonial letters, etc.  
**Success Auto Buggy Mfg. Co. (Incorporated)**  
 528 De Baliviere Ave., St. Louis, Mo.

**Jones Speedometer**  
 The pioneer and accepted standard  
 Automobile Speed Indicator  
 Write for catalog  
**JONES SPEEDOMETER**  
 76th Street and Broadway, NEW YORK  
 Chicago, 221 Michigan Ave. Detroit, 221 J-fifers St. Ave.  
 Philadelphia, 259 N. Broad St. Cleveland, 2841 Euclid Ave.

## Motor Buggies, Little Roadsters

FURNISHED COMPLETE OR PARTS OF SAME



One and Two Cylinders—  
Vertical and Horizontal  
Air-Cooled Motors.  
All Styles of Water-Cooled  
Engines

Friction and Planetary Transmissions  
Single or Double Chain Drive

### DIFFERENTIALS

We Supply all the Necessary Parts to Convert Buggies into Auto Buggies.



NEUSTADT AUTOMOBILE & SUPPLY CO., 3954 Olive St., St. Louis, Mo.

## The "BLOMSTROM THIRTY"

THE MOST FOR THE MONEY EVER OFFERED

1908 Models Now Ready Four-Cylinder, Vertical  
30 H. P. Price \$2,250

Write for Catalog. Representatives wanted for unoccupied territory. Immediate deliveries.

The Blomstrom Manufacturing Company  
DETROIT MICHIGAN, U. S. A.

'08 **DROP** **AXLE** **FORGINGS** '08

## CRANK SHAFT

And all Auto Forgings  
Send specifications for 1908 requirements

BARNETT DROP FORGING CO., East Hampton, Mass.

## Waukesha Motors

have demonstrated their smooth, quiet, speedy and powerful action satisfactorily to their 1907 users. We can take on a few more contracts for 1908 delivery and will guarantee to deliver whatever we contract for. The self-contained oiling system is a feature of our 4½" x 5" and 4¼" x 5" which is well worth looking into.

WAUKESHA MOTOR CO., Waukesha, Wis., U. S. A.

## The Practical Gas Engineer

WHAT TO DO AND HOW TO DO IT. A book of 102 pages neatly bound in cloth. Sent postpaid for \$1.00. Address The Automobile, Flatiron Building, New York.

## "Continental Motors are Standard"

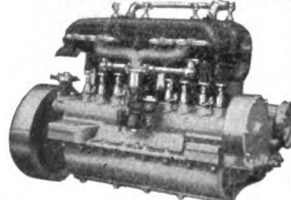

They are made in three sizes of 4-cylinder type, 24 to 50 Horse Power, as follows: 4½ in. x 4½ in.; 4½ in. x 5 in.; and 5 in. x 5 in., equipped with self-contained oiling system and ready for attaching magneto. Efficient, Durable, Simple. Send for catalogue. Also Transmissions and Clutches.

CONTINENTAL MOTOR MFG. CO., MUSKEGON, MICH.

K. Franklin Peterson, Western Representative, 166 East Lake St., Chicago, Ill  
T. J. Wetzel, Eastern Representative, 20 West Forty-second St., New York N. Y.

## SAMSON TYPE COURSE

NON-SKIDDING  
NON-PUNCTURABLE  
STRONGEST ON EARTH

SAMSON LEATHER TIRE CO.  
G. de Pontac, Gen'l Mngr.  
1634-42 BROADWAY, Cor. 50th ST.  
NEW YORK

## McCord FORCE FEED LUBRICATOR

"The Mark of a Good Motor Car"

RADIATORS • CARBURETERS  
MCKIM  
COPPER-ASBESTOS GASKETS

McCord & Company  
1404-1408 Old Colony Bldg., Chicago  
New York Office: 24 Broad St.



# "SOOT-PROOF"

## SPARK PLUG

# \$1

The largest seller of them all. Include it in your 1908 Catalog.

G. A. MEZGER, Inc.  
1759 Broadway, New York

National Sales Corporation, Factory Sales Managers, 206 Broadway, New York

The Best of EVERYTHING for EVERYBODY

That Ever Drives a Motor Machine

WRITE FOR CATALOGUE 70

EXCELSIOR SUPPLY COMPANY  
Established 1876  
233-235-237 Randolph Street  
CHICAGO



### Here's the Stuff

Dixon's Motor Graphite helps compression in cylinders, quiets noise in gears, makes smooth running throughout. Booklet 9 G tells how to use it. Write for free copy

**JOSEPH DIXON CRUCIBLE CO.**  
JERSEY CITY N. J.

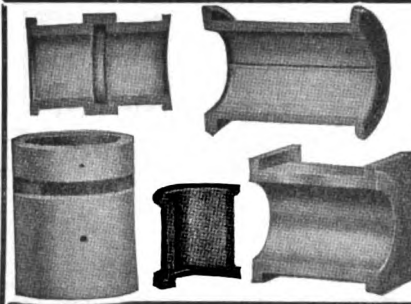

### American Die Castings Co., Inc.

815 S. Delaware St. INDIANAPOLIS, IND.  
Die Casting of all Bearing Metals to 1-1000th inch. Smooth and true as if machine finished. We guarantee castings contain same percentum of alloy as metal furnished. Samples and estimates furnished upon application.

# "RAJAH" SPARK PLUGS

IGNITION ABSOLUTELY SURE  
**RAJAH AUTO SUPPLY COMPANY** 140 WASHINGTON STREET NEW YORK, U. S. A.  
JOHN MILLEN & SON, Ltd. MONTREAL, TORONTO, VANCOUVER

### IF YOU WANT THE RIGHT-OF-WAY USE THE LONG DISTANCE SIREN

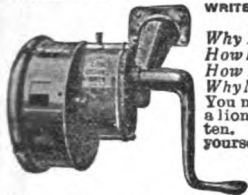

WRITE FOR OUR BOOKLET TELLING YOU  
*Why Its Always Heard.*  
*How Prevents Accidents.*  
*How It Clears the Road.*  
*Why Never Out of Order.*  
You may have the roar of a lion or the purr of a kitten. You get the road to yourself. Everyone turns out and gives you the right-of-way. Beautifully finished in polished

brass and aluminum. An ornament to any car.  
**Stewart & Clark Manufacturing Company**  
506 Diversey Boulevard, Chicago, Illinois.

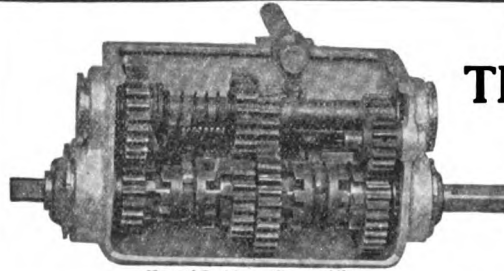

### The COTTA TRANSMISSION

Strength, Durability and ease in handling the lever are its greatest advantages. The jaw clutches do away with gear stripping and make control perfect.

For information write  
**Chas. Cotta, Rockford, Ill.**

### Protect Your Automobile Improvements with Solid Patents

We can handle your business properly, as we are familiar with all types of Autos. are automobile owners and have had twelve years' practice before the Patent Office. Send sketch of your invention for free report as to patentability. Book "How to Obtain a Patent" and "What to Invent" sent Free.

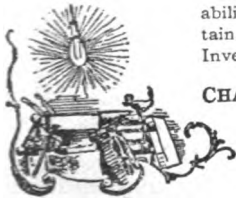

**CHANDLER & CHANDLER**  
Patent Attorneys  
903 F Street  
WASHINGTON, D. C.

WHEN WRITING TO ADVERTISERS PLEASE MENTION THE AUTOMOBILE.

### THE LEAVITT Improved Wipe Contact Timer

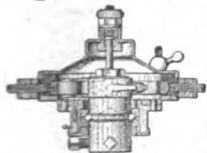

To meet a demand for a wipe contact timer we have improved upon the well-known Lacoste Timer by adding a supplementary ground terminal and an adjustable ball-bearing in place of the plain bearing. This eliminates the two principal faults of this timer, i.e., poor ground and wobbling after running a short time, both of which will cause skipping when running at high speed. The above faults are usually ascribed to the plugs, coils or carburetor.

Send for Catalogue and prices  
**THE UNCAS SPECIALTY COMPANY**  
Norwich, Conn.  
New York Office, 1601 B'way Tel., 5846 Col

# Empire Tires

WEAR LONGEST

EMPIRE AUTOMOBILE TIRE CO., Trenton, N. J.

NEW YORK—148 Chambers St. and Broadway and 73d St. CHICAGO—20 LaSalle St. and 1615 Wabash Ave. BOSTON—292 Devonshire St. BUFFALO—9 West Huron St. PENN AUTO SUPPLY CO., Philadelphia, Pa. FOBES AUTO SUPPLY CO., Portland, Ore. FOBES AUTO SUPPLY CO., Seattle, Washington. WAITE AUTO SUPPLY CO., Providence, R. I. DENVER AUTO GOODS CO., Denver, Col.



"THE OLD RELIABLE"

**DIETZ MOTOR LAMPS**

NONE "JUST AS GOOD"

"Be a little ahead of the others."

Dietz "Empire" Side-Lamps

(Acetylene or Electric)

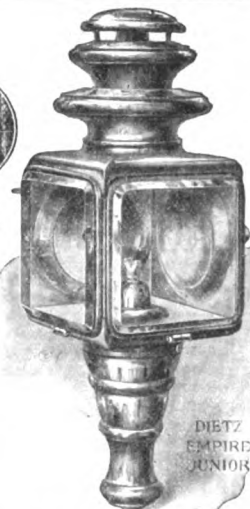

DIETZ EMPIRE JUNIOR

DIETZ EMPIRE

Dietz "Empire" \$11.00 Each

Manufacturers—especially of closed-body cars—find these lamps give a "smart effect" which is helpful as a selling point in increasing sales of cars.

**R. E. DIETZ CO.**, Largest makers of Lanterns in the World  
60 Lighthouse Street, New York  
Est. 1840. Send for 40pp. 1908 Catalog. Interesting prices



*"The NORTHWAY is the BEST way"*  
**Northway Motors** deliver the **Power**

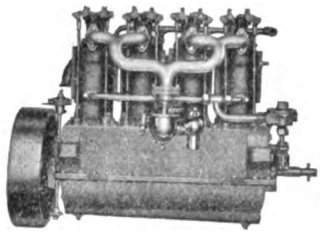

Northway Model "H" for 1908 5"x5"—40 to 45 H P  
 Send for descriptive bulletin of our  
**Motors, Transmission Gears and Clutches**  
*Let us estimate on work from your designs.*  
**NORTHWAY MOTOR & MFG. CO.**  
 G. T. R. R. and Maybury Ave., **DETROIT, MICH**



**Reliance**  
 SPARK PLUGS  
**SPARKS IN WATER**  
 Conclusively proving  
**INFALLIBILITY**

Our price is \$2.50 each, BUT you wouldn't part with them for their weight in gold if you couldn't get another

Perfect Satisfaction  
 Unlimited Durability

**JEFFERY-DEWITT CO.**  
 217-219 High St., Newark, N. J.  
 Department B

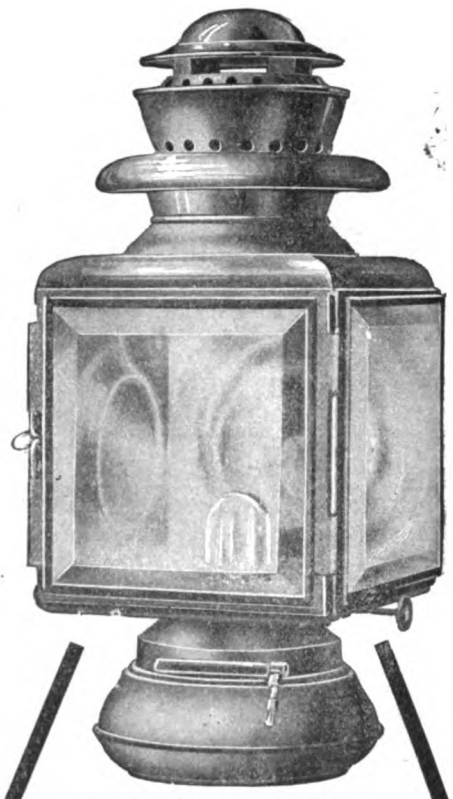

**HAM'S LAMPS**  
 Proved the best  
 By a most  
 Rigid test

You won't have to consider the lamp question long if you give Ham's "Cold Blast" Lamps a trial. They embody all the good features you could possibly expect in oil lamps, and more Style, Finish, Quality of material, Strength of construction and excellent burning qualities. They give an immense light and will not blow or jar out.

Ask the man who has used them and also write for one of our new catalogues. Address "Dept. B."

**C. T. Ham Mfg. Co.**  
 Rochester, N. Y.

# Prest-O-Lite

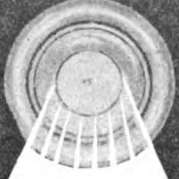

**Light Insurance**  
 Is Better Than  
**Life Insurance**

"LIGHT Insurance" is a thousand times better than LIFE Insurance on a dark, cloudy night, when you're trying to make time over rough, bumpy roads with hidden dangers and obstacles before you. Equip your car with PREST-O-LITE and carry your "light insurance policy" right on the foot board. That's the only sure way to avoid bad accidents and exasperating delays. Prest-O-Lite turns night into day with its strong, steady, white light. It's much cleaner, safer and easier to operate than the ordinary, unreliable, treacherous gas generator.

No matter where you live, you can easily and quickly have your car equipped with Prest-O-Lite, for we now have 1,600 Prest-O-Lite stations scattered all over the country. At any one of these places you can buy a Prest-O-Lite tank or exchange an empty one for one that's filled.

Write for the New Prest-O-Lite Book and learn how to side-step the trouble, worry and accidents of night travel. And do it now—to-day. This interesting little booklet mailed to you at once. Send no stamps—just your name to

**THE PREST-O-LITE COMPANY**

WRITE OUR NEAREST MAIN STATION.

NEW YORK, 1904 Broadway      INDIANAPOLIS, 22-24 S. East St.  
 SAN FRANCISCO, Point Richmond      BOSTON, 607 Boylston St.  
 TORONTO, 6 King Street West

**Q V P      V      W**

**BEST MADE FOR GARAGES**

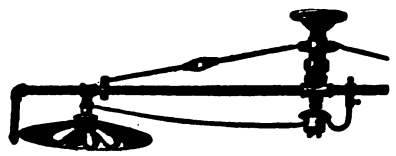

(Plain or Illuminated)  
**SEND FOR PRICES**

**Vehicle Specialty Corp., Hartford, Conn.**

The UNIT SYSTEM

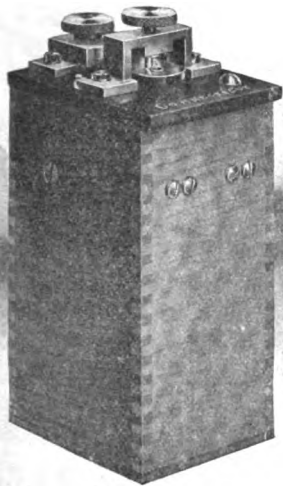

What it Means to the User of the

CONNECTICUT

COIL

Each coil individual  
 One unit to each cylinder  
 All units interchangeable  
 Each unit self-contained  
 No tools to remove a unit  
 No disconnecting of wires  
 Simply throw retainer spring forward  
 Then lift unit from case  
 Replace unit in 20 seconds.

A Distinctive Feature of the CONNECTICUT COIL

Send for Catalog No. 13 B  
 The Connecticut Telephone & Electric Company, Inc.  
 50 Britannia St., Meriden, Conn.

Protect Your New Tires. Repair the Old One

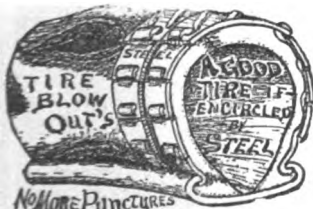

Tires Will Last Forever  
 Steel Link Bands  
 Hooks to Rim

You can fix Blowout quick. If tire is completely covered by these clasps you cannot have Blowouts, Punctures, Rim Cuts or wearing off of tire. As flexible as ever. ANTI-SKID.

KIMBALL TIRE CASE CO.  
 171 BROADWAY, COUNCIL BLUFFS, IOWA  
 State Agent for Indiana:  
 O. H. ROSSER, 415 Mass. Ave., Indianapolis

CORK INSERTS

(PATENTED)

are used in Clutches and Brakes by 44 leading motor car builders for the increased efficiency they give

Write for particulars

NATIONAL BRAKE AND CLUTCH CO., 16 State Street, BOSTON

TRIUMPH GAGE

for GASOLINE TANKS



THE ONLY RELIABLE WARRANTED TANK GAGE. USED ON ALL PIERCE ARROW, WHITE, MATHESON, AUSTIN, ROSS AND OTHER CARS. Send for circular

Boston Auto Gage Co.  
 10 Waltham Street BOSTON, MASS.

The BEMUS DISTRIBUTER  
 BEST in the WORLD

Does Away With All Spark Coils Save One

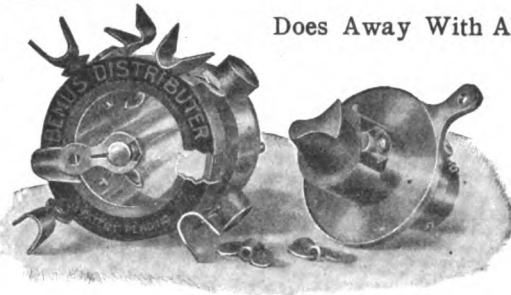

Efficient to an ideal degree. Infallibly accurate, distributes current to cylinder at right instant, making ignition exact. Short circuiting impossible.

BEMUS BALL BEARING TIMER

Has Ground Contact

Is Guaranteed for 60,000 Miles

Provided it is thoroughly lubricated and double ball contacts are renewed every 5,000 miles, which takes but a few minutes and cost 15 cents or less for each set. The contacts are standard 1/8 inch steel balls and may be obtained at any bicycle repair shop or hardware store.

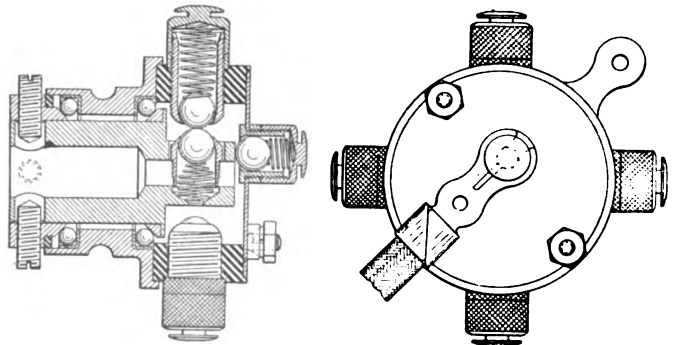

J. Alton Bemus Co., Inc.

358 Atlantic Ave., BOSTON, MASS.



## You Can Buy Satisfactory Finished Crank Shafts if you deal with us



We have proven this time and again to many of the most exacting automobile and engine manufacturers of the country. The crank shafts we are turning out are winning universal approval, due to the wearing qualities of material, and quality of workmanship and finish. Possibly you may be under the impression that what you are using are the best, or at least good enough. If so, it is because you have not tried those we are making. We can convince you of our claim if you will give us an opportunity. All we ask is to simply send blue print or detail drawing, for prices, if you desire a good article. Let us make a sample and submit for your inspection and test.

**STANDARD CONNECTING ROD CO., Beaver Falls, Pa.**

**POYER**  
PLUG

**“There is a Reason.”**

Absolutely Indestructible.  
Has Self-Adjusting Spark Points.  
Requires no Gaskets.  
Made up of only two parts, the body and electrode.

**Price, \$1.50**

MANUFACTURED BY  
**The Motor Car Equipment Co.**  
55 WARREN ST., NEW YORK

## KRUPP SPECIAL CHROME NICKEL STEEL

Grade E. F. 60.0

Now in Stock at New York.

Round bars 1-2 inch to 8 inch diameter, each about 10 feet long. This steel can be used unhardened, having Min. Elastic Limit 95,000 lbs., Min. Tensile Strength 110,000 lbs., Elongation 16 per cent., and Contraction 67 per cent., or can be case hardened or hardened in oil to have more than double the above Elastic Limit and Tensile Strength.

THE BEST FOR MOTOR CARS, BOATS, ETC.

**Thomas Prosser & Son**  
15 Gold St., New York

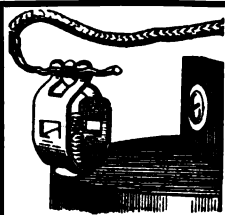

## A LITTLE THING, but what a lot of trouble it saves

THE STANDARD BATTERY CONNECTION for Automobiles and Motor Boats will not jar loose.

The Standard is the only reliable connection on the market. You can depend on having good contact all the time.

They can be quickly attached and detached and are locked in place. There is no nut to work loose. Give them a trial, you will not be sorry.

Price, including connecting wires, \$1.00 per dozen, postpaid.

Standard Battery Connection Co., 27 Copeland St., Roxbury, Mass.

## The Ball Transmission FOR Automobiles & Motor Boats

NEW YORK GEAR WORKS.  
56 GREENPOINT AVE., BROOKLYN, N. Y.

# “CLEANOLA”

**SAMPLE FREE!**

We want to convince every car owner, chauffeur, manufacturer and dealer in the United States that

**“CLEANOLA” OIL POLISH**

is superior to anything in the world for cleaning, brightening and renewing the fine finish, and restoring the surface and “shine” of the varnished wood and metal work, leather trimmings, cushions and tops of your car after each run, and giving them the surface and finish they wore when new, thereby prolonging their life and greatly improving their appearance. If you are not already a user of “CLEANOLA” we will send you a sample free of any expense to you, that you may test its value and prove our claims.

Write to-day. A request carries no obligation. All inquiries answered promptly.

**The Cleanola Company** Dept. 53 W. Van Buren St., Chicago  
“D” 1101 Fulton Bldg., Pittsburgh

## HOPEWELL TIRE CASE

ALL COLORS  
ALL SIZES

**HOPEWELL BROS**  
MANUFACTURERS OF RUBBER AND FABRICS  
100 N. 10TH ST. PHILADELPHIA, PA.

**Users of Invader Oil**

are responsible for its popularity.



TRADE MARK

The oil that graphitizes. You name the car. We'll name the grade.

Made only by  
**CHAS. F. KELLON & CO.**  
128 Arch St., Philadelphia

REGISTERED

**SHALER Electric Vulcanizer**

**\$100.00**



is the price one man says he would not take if he could not get another Shaler Electric Vulcanizer. Why?

(For Private Owner or Garage)

**C. A. SHALER CO., Mfrs.**  
Box R, Waupun, Wis., U. S. A.

**1908 HEITGER**

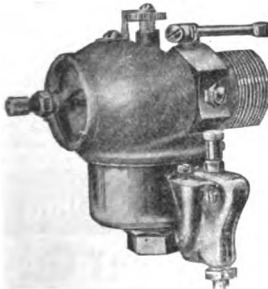

Successful in '07 Improved and better than ever in '08

If in trouble it's the remedy. Guaranteed satisfaction or money refunded.

Address  
**HEITGER CARBURETER CO.**  
205-207 West South St., Indianapolis, Ind.

**The Lightning Kerosene Burner**



More successful use than all other makes combined. It pays for itself. Ask for catalog of this as well as other up-to-date Steam Appliances.

**E. C. WALKER MFG. CO.**  
811 Nelson St., Louisville, Ky.



**WEED'S CHAIN TIRE GRIPS**

NECESSARY AS GASOLINE

**Positive Traction Prevents Skidding**

Ask Any Experienced Driver and You Will Buy a Pair.

**SOLD EVERYWHERE**

**WEED CHAIN TIRE GRIP CO.**

28 Moore Street  
**NEW YORK**

**We Are Now Booking 1908 Orders**

Limousine  
Landaulette  
Touring Car  
Runabout  
Racing

**BODIES**

We furnish bodies in white or finished complete.

We operate one of the largest wood-working plants in America, devoted to body building exclusively.

SEND SPECIFICATIONS—WE QUOTE PRICES

**MILLER BROS.** Amesbury Mass.

# PITTSFIELD



## PITTSFIELD IGNITION

THE STANDARD EQUIPMENT  
FOR THE BEST AMERICAN  
BUILT CARS.

Highest grade quality in every detail of design, workmanship, material and every up-to-date improvement.

We are *manufacturers*, not assemblers. Every part used in our ignition is made in our own plant, which enables us to unrestrictedly guarantee our products.

# COLLS

WE MANUFACTURE A FULL LINE OF  
**Magnetos, Spark Coils,  
Switches, Timers, Spark Plugs,  
and all Ignition**

for Automobiles, Motor Cycles and Launches.



1908

Line Now Ready

Our new and enlarged factory gives us facilities for handling the ignition business of the world with promptness and dispatch.

WRITE TO US.

Pittsfield Spark Coil Co., Dalton, Mass.

DISTRIBUTING AGENTS

Excelsior Supply Co., Randolph St., Chicago, Ill., Western Distributors.  
New York Sporting Goods Co., 17 Warren St., New York, New York Distributors.  
Pettingell & Andrews, Pearl and Atlantic Ave., Boston, New England Distributors.

# DALTON MASS.

## POCKET Battery Ammeters



Voltmeters and Volt - Ammeters, Current Indicators for Spark Coil Testing.

Small Switch-board Instruments, Etc.

Accurate, Durable Largest Makers in U. S. A.

Sold by Jobbers and Dealers

ELDREDGE ELECTRIC MFG. CO.  
33 Post Office Sq., Springfield, Mass., U.S.A.



## Worth their Weight in Gold to Any Car

The only practical cure for hard riding cars, relieving the body of all injurious shocks, jolts and jars. No more broken side springs. Fully patented and fully guaranteed. See our exhibit at all Automobile Shows and send for our new booklet—it's interesting. Beware of worthless imitations.

Supplementary Spiral Spring Co.  
4529 Delmar Ave.,  
ST. LOUIS, MO.

New York, 52 W. 67th St.



**THE IMPROVED VIM SPARK PLUG**  
10 per cent. more power or your money back. Not simply a spark, but a blast of flame; quicker than the ordinary plug. Has two porcelains and a mica tube; the best insulated plug out. The spring at the end prevents cracked porcelains. Price \$2.00.

THE K-W IGNITION CO., 34 Power Ave., Cleveland, O.

WRITE FOR NEW CATALOG

**THE AUTOMOBILE SUPPLY CO.,**  
1339 MICHIGAN AVENUE,  
CHICAGO.

SPECIAL ATTENTION TO MAIL ORDERS

## Searls Folding Jacks



Have lightest weight, guaranteed strength, usable broad base or folded narrow base, latest construction, foot power. Why get down in the dirt? Ask your dealer or we deliver in U. S. or Canada.



Jersey Brake Co., 3 Greene St., Newark, N. J.

**MARINE MOTORS**  
 STATIONARY GAS ENGINES  
**AIR SHIP MOTORS**  
 2-Cycle Gasoline Motors



GASOLINE PUMPING OUTFITS

Send for 1907 Catalog  
**THE AERO AND MARINE MOTOR COMPANY**  
 60 Pemberton Square, Boston, Mass.

**MOTOR CAR**  
**DROP FORGINGS**  
 AXLES IN ONE PIECE  
**BETHLEHEM STEEL COMPANY**  
 South Bethlehem, Pennsylvania

Branch Offices: Boston, 165-7 High St.; New York, 100 Broadway; Philadelphia, Pa., 15th and Chestnut Streets; Pittsburg, Pa., Keystone Bank Building; Chicago, Ill., Fisher Building; San Francisco, James Flood Building.

**THE CROWN DRY CELL**



will hold up longer and has greater recuperative power than any other cell made.  
 Get a set for your car.

**CROWN BATTERY COMPANY**  
 192 Southern Boulevard  
 NEW YORK

National Sales Corporation  
 Factory Sales Managers  
 296 Broadway, New York

**The Beilfuss Auto Engine**

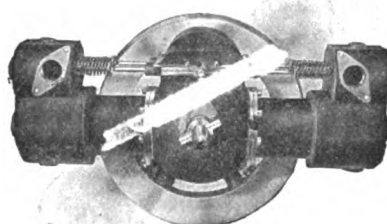

18-20 H. P. double opposed cylinder. Bore and stroke 5x5 inches. Weight 300 lbs. Perfectly made.

Price right. Send for circular and price. Immediate shipment. Ask about our 10-12 H.P. air or water cooled motors, ready September.

**The Beilfuss Motor Company - Lansing, Michigan**

**MONOGRAM OIL**  
 Is Best For Your Engine

No automobile engine can do its best without the right sort of lubricant. Monogram Oil is refined in distinct grades for different engines.

Don't ask simply for "Monogram." Give us the name of your car and we'll tell you what grade of Monogram is best for your engine.

**Columbia Lubricants Co., of New York**  
 78 Broad Street, New York City

**Special Introductory Offer**  
 33 1/3 PER CENT. FROM LIST PRICES



	List Price	Special
Leather covered Buffalo robe, cloth lining	\$15.00	\$10.00
Same with window	16.50	11.00
Leather covered, lined with fur	20.00	13.33
Same with window	21.50	14.33

The same good, warm, comfortable muff. No reduction in quality. We are simply giving you the dealer's profit.

We have no representatives. Order direct, giving diameter of wheel, diameter of post and control rods running parallel, if any, and location of spark and throttle; name the car, and the Muff will fit.

**Mandeville Steering Wheel Muff Co., Bluffton, Ind.**

**MILLER'S** 

**Anti-Freeze Compound**



Ten pounds of this compound added to two gallons of water will not freeze at 15 degrees below zero. Price of 10-pound can, \$1.00

Our Catalog, largest of its kind, mailed on request.

MANUFACTURED ONLY BY  
**CHAS. E. MILLER, 97-99-101 Reade St., New York**

Branches: NEW YORK BOSTON PHILADELPHIA  
 CLEVELAND DETROIT BUFFALO

**THE Jencick Motors**

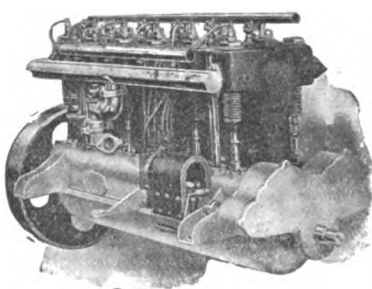

Suitable for Pleasure Cars and Heavy Duty Trucks, where reliability and efficiency are wanted.

H. P. 12 to 70, 2-4 and 6 cylinder, watercooled, four cycle, make and break and jump spark. Krupp chrome nickel steel. Parsons' manganese bronze base. Hess & Bright ball-bearings — simplicity of design and experienced workmanship. These are some of the Jencick features.

**MOTORS BUILT BY NONE BUT SKILLED LABOR**

and the above-mentioned materials, will have everlasting efficiency and durability. We will be pleased to mail catalogue on request.

**JENCICK MOTOR MFG. CO., Port Chester, N. Y**



# AUTOGAS

SUPPLIES LIGHT TO ANY  
AUTOMOBILE LAMP

LASTS FOR MONTHS

IT GIVES TWICE THE SERVICE OF  
ANY OTHER GAS TANK. WRITE US

## Avery Portable Lighting Co.

NEW YORK OFFICE  
51 W. 63d Street

MILWAUKEE  
WIS.

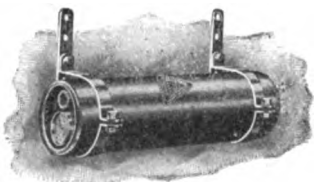

## G. and C. Revolving Auxiliary Chair Seat

It revolves in any position,  
folds up, and is fastened to the  
tonneau by a special bracket so  
it is easily adjusted or removed.

Sold in the white or  
upholstered.  
High Grade Bodies.  
Limousines our Specialty  
**Graves & Congdon Co.**  
AMESBURY, MASS.



# "TRIUMPH" GREASE

**NO WASTE—NO WEAR**

Works the same Winter and Summer, being  
unaffected by heat or cold.

Never runs out. Owing to its heavy body it stays  
where it is put and does not waste off like oil. Being  
heavy-bodied, it always leaves a layer of grease be-  
tween the opposing surfaces, reducing friction to a  
minimum and saving wear. Its molecules are practi-  
cally indestructible and it lasts in ACTUAL WORK  
from 50 to 100 per cent. longer than other lubricants,  
therefore is immensely cheaper. Send a trial order to-  
day 10 lb. Can \$2.00. For sale by all dealers, or  
send order direct to

**The Perfection Grease Co., South Bend, Ind.**

Agencies: Excelsior Supply Co., 233 Randolph Street,  
Chicago. R. E. P. Sporting Goods Co., 1384 Bed-  
ford Avenue, Brooklyn, N. Y.

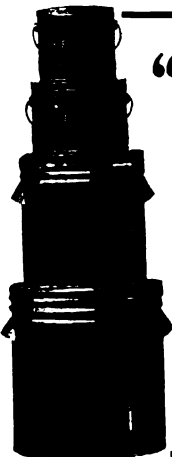

## "Porox" Ignitor Storage Batteries

FOR IGNITION AT HIGH SPEED  
AND CLIMBING HILLS  
NONE BETTER

High Capacity Light Weight

The only American ignition ac-  
cumulators put up in celluloid jars.  
They surpass in capacity, lightness  
and durability the imported French  
cells. 1,500 miles on a single charge  
with a 4-cylinder car. We guaran-  
tee more mileage than any other make.

Write for circular and price list.

MANUFACTURED BY

**ALBERT MULLER**

205 West 41st St. New York City



# BUCKEYE

# AUTOMOBILE JACKS

**STRONG, SAFE,  
RELIABLE**

Highest Grade Material and  
Workmanship. The re-  
sult of 20 years exper-  
ience in Jack building

Especially suitable for au-  
tomobile use. Can be  
operated under any au-  
tomobile.

Made only by the  
**Buckeye Jack Mfg. Co.**  
Louisville, Ohio



The only Jacks on the  
market having High Car-  
bon Crucible Steel Drop-  
forged Racks and Paws,  
insuring against breaking  
down under load

Distributing Agents:

Post & Lester Co., Hart-  
ford, Conn.; distributors  
for New England States.  
M. G. West & Co., San  
Francisco, Cal.; distribu-  
ting agents for the Western  
Coast.

## K-B Ball Bearing Universal Joint

**SIMPLE, STRONG  
AND DURABLE  
PERFECT LUBRICATION**



Patented in United States  
Patents in the foreign countries pending

**The KINSLER-BENNETT COMPANY**

HARTFORD, CONN.

Sold by The American Distributing Co., 610 American Trust Bldg., Cleveland, O.

THE  
CLEVELAND-  
CANTON  
SPRING  
CO.

**Oil Tempered Special Heat Treated  
Perfect Fitting**

As a measure of protection to your cars, specify  
Cleveland-Canton Springs on your 1908 product.  
In quality of materials, scientific workmanship and per-  
fect fitting, our springs are not approached by any  
other make. Write to us—we'll explain how  
our special process does it.—Write today.

**THE CLEVELAND-CANTON SPRING CO.**  
CANTON, OHIO

**AUTOMOBILE  
SPRINGS  
OF EVERY KIND**

One of Our  
Various  
Shapes

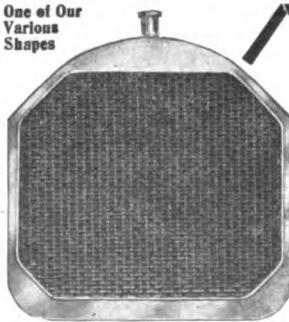

## Wright Coolers

The Cooler that Cools—The Most Effective  
Radiator Made. Eliminates all Radiator  
Trouble. It always cools and never steams  
because of its special construction for fur-  
nishing cold air to all parts. There is no  
vibration to the tubes, hence no leaks from  
any cause, except accidents and then easily  
repaired. It is lighter than others. You  
can freeze it and thaw it out—no damage.  
It has stood the most severe tests on all  
kinds of Touring, Commercial and Racing  
cars. Up-to-date 1908 designs

**THE WRIGHT COOLERS** are hand-  
some in appearance and as nearly inde-  
structible as can be made. Workmanship  
and material guaranteed perfect. Send us your blue-prints and let us quote  
you prices. Sold singly or in quantities. Write to us

**Wright Cooler and Hood Mfg. Co.** 1547 Michigan Ave. Chicago, Ill.  
Makers of Patented Invisible Hinge Hoods, also Blue of Fenders, Dashes and Tanks to order



**The Only Folding Wind Shield**  
that is automatically held open or shut, that won't rattle and can be operated by the driver with one hand without stopping the car.



**Conover Wind Shield**  
**CONOVER MOTOR CAR CO.**  
Paterson, N. J.  
National Sales Corporation  
Factory Sales Managers  
296 Broadway New York

**Mound Tools**  
For the Automobile



Cut represents our new set of 20 tools gotten up for use in auto repair work. Strictly high-grade tools with all the good points of tool-smithing in their make-up. Conveniently arranged in finished oak case, and every tool is highly polished and guaranteed.

No. 1 Set of 20 Tools, - \$4.50  
No. 22. Set of Six Mound Hollow Ground Scraping Tools, Oak Case, - 3.00  
No. 25. Set of 3 Carbon Scrapers - 2.50  
If your dealer cannot supply you, we will. Send for free circular.

**MOUND TOOL AND SCRAPER COMPANY, Toolsmiths**  
708 Howard Street, ST. LOUIS, MO.

**YOU WANT THE BEST GET A HICKS!**



Speed Indicator  
Elgin Watch  
Veeder Odometer  
ALL ON ONE DIAL  
Size 4x4 inches  
Price \$50 Complete  
Fully Guaranteed  
SEND FOR BOOKLET

**HICKS SPEED INDICATOR CO.** 1263 Atlantic Avenue  
BROOKLYN, N. Y.

**GET OUR REDUCED PRICES**

As long as price of raw rubber is down we will sell tires at interesting prices

Get our booklet "Story from Users," also our catalog "C"

**The Swinehart Clincher Tire & Rubber Co.**  
Western Office 123 1/2 Michigan Blvd., Chicago, Ill.  
Main Office and Factory AKRON, OHIO

**INSIST UPON A RADIATOR EASILY REPAIRED**

**LONG'S RADIATORS**



are the only ones on the market that can be repaired when an accident is met with. Any broken tubes can be replaced with new ones at a small expense. Other makes of radiators when damaged must be entirely replaced at a heavy expense. Send for Catalogue.

**LONG MANUFACTURING CO., Chicago, Ill.**

**The Rutenber Line**

30 to 60 H. P.  
4-cylinder, 4 1/2 x 5 } EQUIPPED WITH OR  
4-cylinder, 4 1/2 x 5 } WITHOUT MAGNETO  
4-cylinder, 5 x 5 } AND CARBURETOR  
6-cylinder, 4 1/2 x 5 }

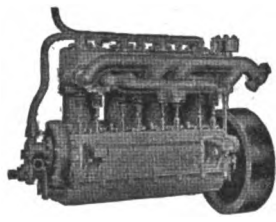

The Rutenber Motor holds world's record of 1,094 3-16 miles in 24 hours. Rutenber Carburetors best of all. For your own benefit get further particulars. Let us figure on your 1908 requirements. Let us prove by test our motors are far the best and that they are the motors you should have on your cars. Write to-day!

**Rutenber Motors and Carburetors the Best for Your 1908 Cars**  
Motors and Carburetors of the highest quality embodying in their construction the most skilled workmanship and the best material obtainable, at a cost no greater than you are asked to pay for machines that are unreliable and that will last only a short time. Made in the largest factory in this country devoted exclusively to the manufacture of motors and carburetors. 30 to 60 H. P. 4 and 6 Cylinder Motors. Write for Catalogue.

**THE WESTERN MOTOR COMPANY, Logansport, Ind.**

HIGH GRADE

**Alpha**

PURE SEAMLESS

**INNER TUBES**

THE STRONGEST TUBE MADE IMPORTED OR DOMESTIC

**PARKER, STEARNS & COMPANY,**  
228 & 229 South Street, New York.

The "HELE-SHAW" CLUTCH RECORD

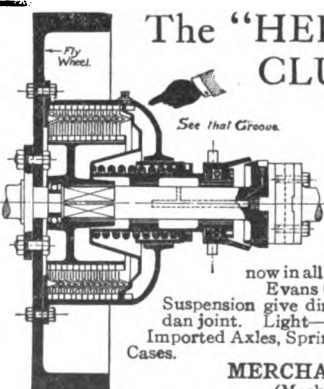

Thornycroft—Mitsue—Daimler Buses (Mercedes Co.)—Benz—Napier—New Arroll—Johnson—Humber—Eugene Brill—Buses—Delahaye, etc. BRITISH ADMIRALTY.—H. M. S. "Dreadnought" Launches and submarine equipped with Hele-Shaw Clutch Reversing Gear.

20,000 H. P. Hele-Shaw Clutches now in all kinds of industrial work. Evans Change Speed Gears and Spring Motor Suspension give direct drive on two speeds without Cardan joint. Light—durable—highest efficiency. Imported Axles, Springs, Chassis, Special Steel, "Star" Tire Cases.

**MERCHANT & EVANS CO.**  
(Mechanical Department)  
PHILADELPHIA NEW YORK CHICAGO BALTIMORE KANSAS CITY

THE NEW YEAR WILL PROVE A HAPPY ONE FOR YOU AS FAR AS THE IGNITION PROBLEM IS CONCERNED IF YOU USE



NATIONAL CARBON COMPANY, CLEVELAND, OHIO

HYATT

FLEXIBLE ROLLER



BEARING

Specify them before you buy

HYATT ROLLER BEARING CO., Harrison, N. J., U. S. A.

You'll have enough other troubles

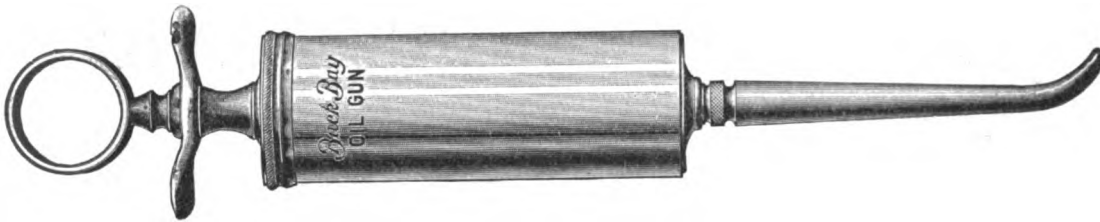

B - LINE

Oil-Grease Guns

ALL METAL CONSTRUCTION  
PISTON GROoved TO FIT

Write for Catalog J

Randall-Faichney Co.  
BOSTON, MASS.

WE MANUFACTURE FOR THE AUTOMOBILE TRADE

Complete Front and Rear Ball-Bearing Axles

THAT ARE WELL-KNOWN FOR DURABILITY AND EFFICIENCY

Call on or write us regarding your requirements.

THE AMERICAN BALL-BEARING CO., CLEVELAND OHIO, U. S. A.



FASTENERS

All styles and sizes for AUTOMOBILES. Now used on the leading Motor Cars. Prompt Deliveries. Write for prices.

UNITED STATES FASTENER COMPANY

Manufacturers of Snap Fasteners and Metal Goods.  
95 MILK STREET, BOSTON, MASS.

Represented at  
NEW YORK CITY  
450 Broome St.

CHICAGO, ILL.  
237 Fifth Ave.

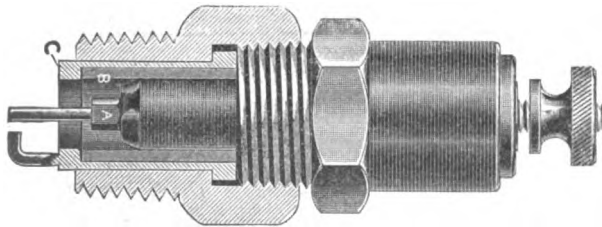

2 Plugs in 1

"Wiley" Mica Spark Plug has many original features, one of which is its renewable cartridge. When Plug becomes dirty (as all Plugs will) the cartridge is removed and replaced by a new one. No delay en route. 2 Plugs for the price of one. Price, \$1.50. Extra Cartridges, 25c each.

THE HUB LUBRICATOR COMPANY

80 Portland Street, BOSTON, MASSACHUSETTS



SPRING WINDER



Will earn its cost in one day's use. Indispensable to the Automobile Owner, Repairman and Builder. Adopted as standard for the winding of all kinds, sizes and shapes of coil springs by the foremost manufacturers in this and foreign countries.

TWO SIZES

Capacity of small size up to 3-32 inch wire, Price \$1.00  
Capacity of large size up to 3-16 inch wire, Price \$1.50

REMINGTON TOOL & MACHINE COMPANY  
BOSTON, MASSACHUSETTS



## THE TANK THAT SAVES

The loss of 15 to 50 per cent. from evaporation, usual with the ordinary method of storing gasolene, besides that caused by dripping and careless handling, is prevented by the BOWSER OUTFIT

### THE STANDARD GARAGE EQUIPMENT FOR GASOLENE STORAGE

The Bowser Tank is absolutely evaporation proof. The Bowser Pump will not allow dripping, and it measures accurately any desired amount, thus preventing you from trying to pump more gasolene than your reservoir or can will hold

Send for catalog J. It explains all the Bowser Gasolene Outfits

**S. F. BOWSER & CO., Inc., Fort Wayne, Indiana**

255 Atlantic Avenue BOSTON, MASS. 290 Broadway NEW YORK CITY 209-210 Fisher Building CHICAGO, ILL. 66-68 Frazer Avenue TORONTO, CANADA

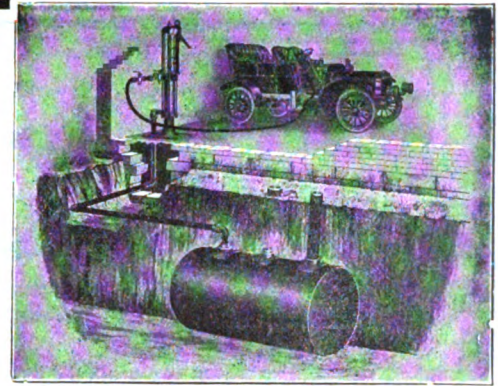

Cut 41—LONG DISTANCE OUTFIT. The Standard Garage Equipment for Gasolene Storage



# WELDING BY ELECTRICITY

INSURES  
STRENGTH, ACCURACY AND DEPENDENCE

## THE STANDARD WELDING CO. CLEVELAND.



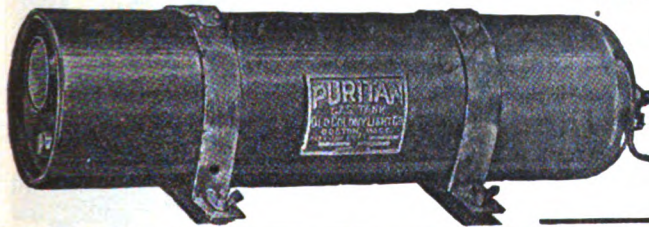

## Puritan Gas Tanks

AMPLE FACILITIES FOR RECHARGING ALL SORTS OF TANKS PROMPTLY  
Retail Price, \$85.00  
More gas for less money

Manufactured by **THE OLD COLONY LIGHT CO.**  
819 Boylston St., Boston, Mass.

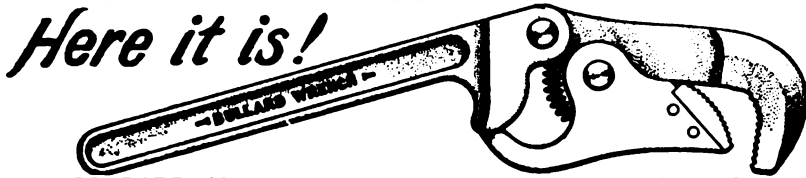

*Here it is!*

**BULLARD AUTOMATIC WRENCH CO., PROVIDENCE, R. I.**  
Try us for high grade drop forgings Quick deliveries.

## BULLARD AUTOMATIC WRENCH

The wrench with the human grip. For use anywhere and everywhere, on anything and everything. Special proposition to manufacturers for your 1908 tool kit.

Motorists: Specify Bullard No. 2 or buy from nearest dealer to get maximum wrench efficiency

Sales Agent, **JOHN H. GRAHAM & CO.**  
113 Chambers Street, New York City

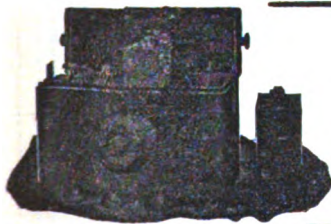

# HEINZE COILS

SEND FOR 1908 CATALOG AND PRICES

**HEINZE ELECTRIC COMPANY Lowell, Mass.**

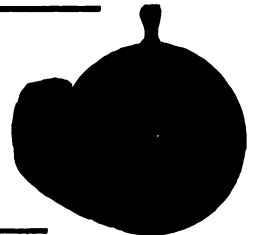

N. B. C.

# National

STORAGE BATTERIES

MAXIMUM  
MILEAGE  
MINIMUM  
MAINTENANCE

# WHEN

USING  
"NATIONAL"  
STORAGE BATTERIES

## National Battery Company

NEW YORK General Offices and Works: BUFFALO, N. Y. CHICAGO



## "WHITNEY" CHAINS

New Fireproof Factory. New Machinery and Improved Methods.

**THE WHITNEY MFG. CO., Hartford, Conn.**



# ECO

## A Storage Tank You Can Recharge Yourself

The ECO STORAGE TANK and GENERATOR COMBINE is the only device that can show 100 per cent. efficiency. The reason is that it stores up all over and after-generation, permitting it to escape only at the lamp burners in the form of light.

The gas and unused carbide will remain in it for months without waste, ready for instant use.

RESPONSIBLE  
AGENTS  
WANTED IN  
EVERY CITY AND  
TOWN.  
WRITE FOR  
TERMS AND  
TERRITORY

**Eco Manufacturing Co.**  
53 STATE STREET, BOSTON, MASS.



Go South to the  
Land of Sunshine  
**Piney Woods  
Inn**  
Southern Pines,  
N. C.

¶ Southern Pines, N.C., has been aptly termed the "Capitol of Sunshine Land." In the long leaf pine region, sandy soil, a mild, dry climate, tempered by the winds of the Gulf Stream. No fogs, no dews, no malaria. Pure spring water. ¶ Golf links surround Piney Woods Inn. No charge to hotel guests for use of links. Ideal conditions for golf prevail at Southern Pines. Not too cold—not too warm, and a "sporty" course in perfect condition. ¶ Saddle riding, tennis, trap shooting and all outdoor sports. ¶ No consumptives received. ¶ An elegant hotel. Rooms en suite with private baths. Rates \$2.50 to \$5.00 per day. **ST. JOHN & SON, Managers.** Parties en route for Pinehurst, Camden and all Florida points, should stop over at Piney Woods Inn—on the main line of the Seaboard Air Line. Superb passenger service: Pullman's latest cars. SEND FOR BOOKLET.

# BUMPS

Have no terrors for the man who has Gabriel Shock-Absorbers on his car. The Gabriel Shock-Absorbers, by friction, retard the motion of the springs above and below their natural flexibility. Fitted to any car or any spring.

Ask for Gabriel Shock-Absorbers, Horn and Cut-Out Valve on your 1908 Car. Write for booklet and prices.

**GABRIEL HORN MFG. CO.,**  
1410 East 40th St., Cleveland, Ohio.

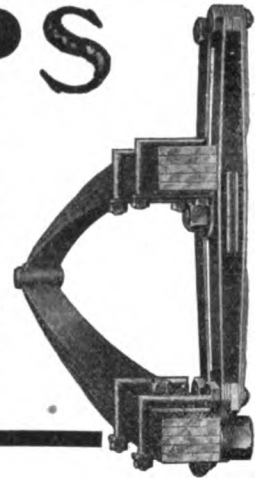

# The "Nightingale" Whistle

**ASSURES RIGHT OF WAY**

On Automobiles

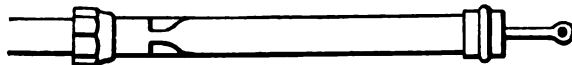

On Motor Boats

YOU CAN FIND NOTHING MORE

MELODIOUS—ATTRACTIVE—PENETRATING—SIMPLE

Can be readily heard at great distances.  
Operated by the exhaust with lever, handle or pedal.  
Automatically cleans itself after every operation.

**WE HAVE NO COMPETITOR IF YOU WANT THE BEST**

*See our Exhibit at No. 42, Importers' Automobile Salon*

For sale by all auto supply dealers. Send for catalog No. 16, which gives full information and price.

**COMPTOIR D'INNOVATIONS POUR AUTOMOBILES**

16 Avenue de la Grande Armée, Paris. **NEW YORK OFFICE: 1693 Broadway**

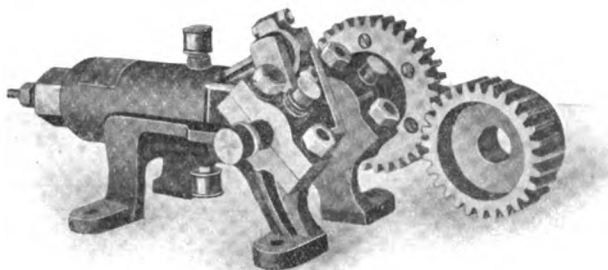

Size 11x15 Inches

**GUARANTEED FOR THREE YEARS**

*The*  
**“Tire Inflator Delpauch”**

**MADE ENTIRELY OF METAL. NO LEATHER PACKING**

The “Tire Inflator Delpauch” can be attached to any car by means of a split gear on the driving shaft, operated by a sliding pinion.

The Delpauch will inflate the largest tire in one minute, giving pressure up to 90 lbs. within 45 seconds. With the Delpauch, proper inflation of the tires, without effort, is always possible, adding to the life of the tires and to the service of the car.

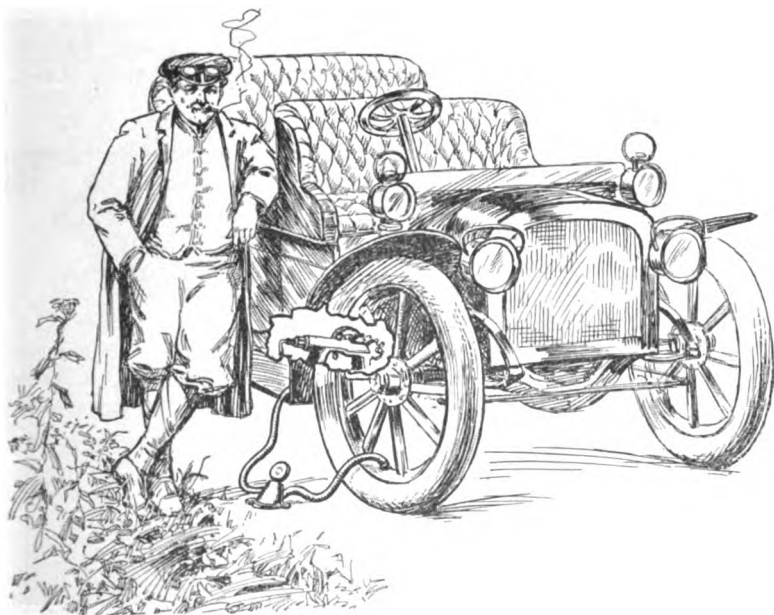

**Sold by**  
**All Automobile**  
**Supply Houses**

Catalog No. 16,  
 giving  
 full information  
 and price,  
 free.

**Exhibited at the Importers’  
 Automobile Salon, Madison  
 Square Garden, Space 42.**

**Comptoir d’Innovations pour Automobiles**

16 Avenue de la Grand Armee, Paris

1693 BROADWAY, NEW YORK



# F. A. Brownell Motor Company

POWERFUL—RELIABLE

Motor of Acknowledged Superiority

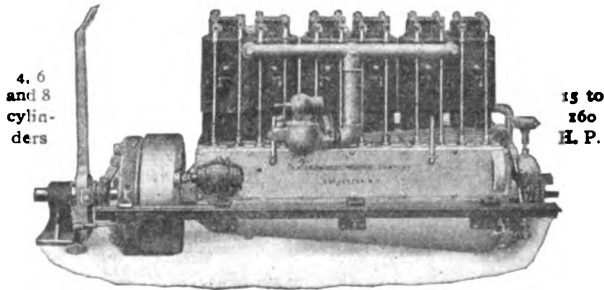

6-cylinder, 75-80 H.P.

4, 6  
and 8  
cylinders

15 to  
160  
H. P.

Embodies the most scientific and approved principles of internal combustion engine construction.

Motors for Automobile, Marine, Tractor, Suburban Car, and other purposes.

A postal—a catalogue.

## F. A. BROWNELL MOTOR COMPANY

Successors to BROWNELL-TREBERT COMPANY

634-666 LEXINGTON AVE., ROCHESTER, N. Y.

**MASURY**  
AUTOMOBILE  
**COLORS**

**MASURY**  
AUTOMOBILE COLORS AND VARNISHES

MANUFACTURED BY  
**JOHN W. MASURY & SON**  
NEW YORK  
CHICAGO .. ST. LOUIS .. MINNEAPOLIS

**MASURY**  
AUTOMOBILE  
**VARNISHES**

# TIRES

ARE ALWAYS SATISFACTORY.

Years of study and experience are necessary to produce a tire that will prove satisfactory under all conditions. Our plant is devoted exclusively to the manufacture of pneumatic tires, and as pioneers in that line we have had the necessary experience, and the results of our close study in one line exclusively are shown in our line of 1908 tires.

Equip your cars with 1908 G & J Tires and Midgley Universal Rims, and you will have absolute tire protection.

# G & J TIRE Co.

INDIANAPOLIS, IND.

**BRANCHES**

BOSTON: 243 Columbus Ave.	CHICAGO: 1434 Michigan Ave.
DETROIT: 247 Jefferson Ave.	SAN FRANCISCO: 423-433 Golden Gate Ave.
NEW YORK: 10 W. Sixtieth St.	
CLEVELAND: New No. 1837 Euclid Ave.	

**DISTRIBUTING AGENCIES**

DENVER: 8528 Court Place.	MEMPHIS: 181-183 Madison St.
BUFFALO: 912 Main St.	PORTLAND, ORE.: 64-66 Sixth St.
PHILADELPHIA: 711 N. Broad St.	MINNEAPOLIS: 21 S. Second St.
LOS ANGELES: 1010 S. Main St.	SYRACUSE, N. Y.: 212-214 S. Clinton St.
OMAHA: Eleventh and Farnum Sts.	ROCHESTER, N. Y.: 55 Main St. East.
PITTSBURG: 913-915 Liberty Ave.	
ST. LOUIS: 415 North 4th St.	
ATLANTA, GA.: 35 N. Prior St.	

## HERCULES SHOCK ABSORBERS

on your car Increase Safety, Comfort, Speed; Reduce Vibrations, Rebounding and Shocks. Save Springs, Axles, Tires, Repair Bills.

See these Auxillary Springs?

They carry the car comfortably over smooth roads

This friction resistance positively controls Bumping, Vibration and Rebounding on rough roads.

**SATISFIES**

Every User In all conditions	Everywhere All the time
---------------------------------	----------------------------

Ask the man who drives a car equipped with **HERCULES**

### Hercules Auto Specialty Mfg. Company

CHICAGO, 115 Dearborn St.  
LOS ANGELES, 936 Denver Ave.

Sales Agents  
**NATIONAL SALES CORPORATION, New York, Chicago**



**THE NEW YORK PARK BOARD'S RULING AGAINST CHAINS ON TIRES**

has no terrors for the thousands of users of Hartford Midgley Tread Tires. They are "legal" in any park or on any road anywhere. Owners know by experience that their car and its occupants are safeguarded against the  
**DANGEROUS SIDE SLIP BY**

**HARTFORD MIDGLEY TREAD TIRES**  
**Clincher or Dunlop**

Easily the greatest non-skid device of the age. Absolutely Safe, Sound, Successful and Sightly.

Four coils of heavy steel piano wire vulcanized right in the heavy tread of the highest quality Hartford Tire, which means the very best in the world, makes the tire get a grip on the ground like "cat's claws." See cuts. Made in Clincher and Dunlop

At the New York and Chicago National Automobile Shows Hartford Midgley Tread Tires predominated six for one over any other make. Especially were they conspicuous on "classy" town and touring cars. Hartford Midgley Tread Tires have won more hill-climbing, road and touring records the past season than any five combined of any other make. Endorsed by the press, professional chauffeurs and owners

**MILLIMETER SIZES FOR FOREIGN CARS**

**GET THEM ON YOUR CAR NOW**

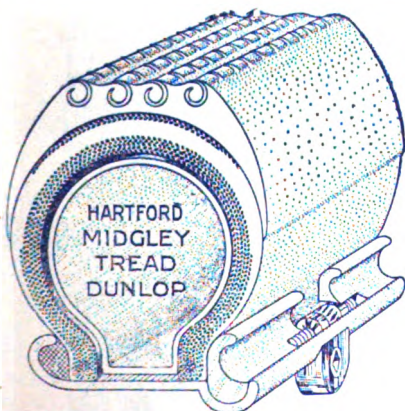

On New Midgley Universal Rim

**The Hartford Rubber Works Co. Hartford, Conn.**

**BRANCHES**

New York, 57th St. and Broadway; Chicago, 83 Michigan Ave.; Boston, 494 Atlantic Ave. and 817 Boylston St.; Cleveland, 1831 Euclid Ave.; Detroit, 256 Jefferson Ave.; Denver, 1564 Broadway; Philadelphia, 1425 Vine St.; Buffalo, 725 Main St.; Atlanta, Ga., 55 Auburn Ave.; Los Angeles, 1505 So. Main St.; San Francisco, 423-433 Golden Gate Ave.

**AGENCIES**

Gugler Electric Mfg. Co., Minneapolis; Mercantile Lumber & Supply Co., Kansas City; F. P. Keenan Co., Portland (Ore.); Salt Lake Hardware Co., Salt Lake City; Compania Mexicana de Vehiculos Electricos, City of Mexico; The St. Louis Tire Agency, 3685 Olive St., St. Louis, Mo.

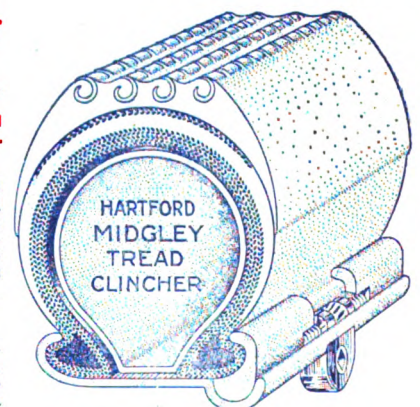



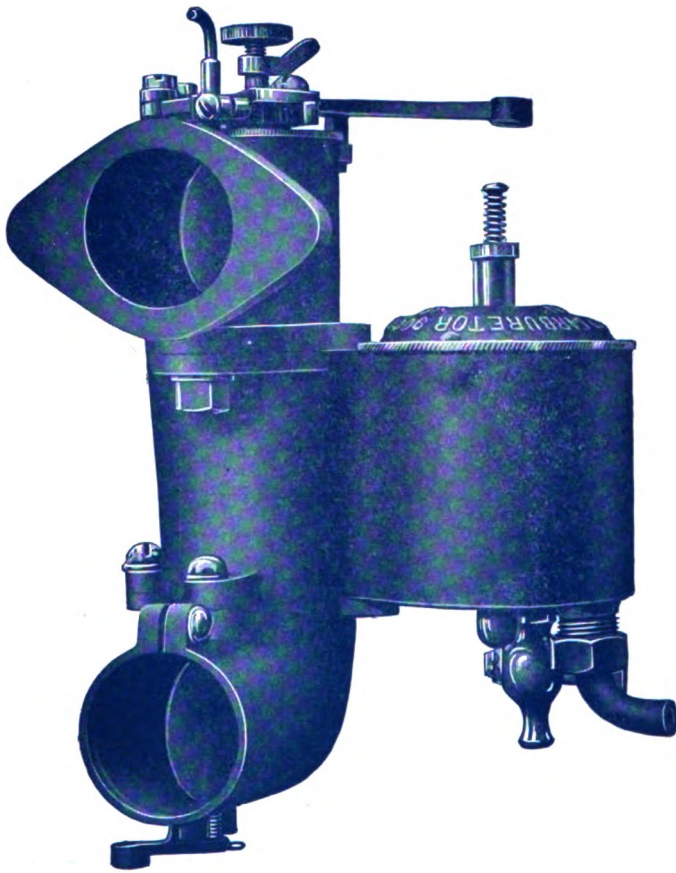

# SIMPLICITY ECONOMY POWER

The new 1908 Buffalo Carburetor is mechanically operated, always acting with the precision of a perfect machine under all conditions. Skilled workmanship, the finest materials and perfect design also help to make it the best carburetor on the market

## **FLEXIBLE—RELIABLE—DURABLE**

**THE BUFFALO CARBURETOR CO.**

**887-889 Main St.  
BUFFALO, N. Y.**

National Sales Corporation, Factory Sales Managers, 296 Broadway, New York.

# Automobile Official Blue Book

SECTION No. 1

## New York Canada and West

622 PAGES

Size 5 1-2 x 9 1-2 inches

Covering New York State, Lower Canada, and Trunk Lines through to the Middle West.

Containing 328 Routes, covering 21,820 miles of Roads

Fully Illustrated and Described by Text, and

254 MAPS

96 Route Maps, 132 City Maps, 26 Full Page Maps, 5 Double Page Maps.

Published in Three Volumes

SECTION No. 2

## New England

534 PAGES

Size 5 1-2 x 9 1-2 inches

Covering New England, with Extension Routes into the Provinces.

Containing 285 Routes, covering 17,469 miles of Roads

Fully Illustrated and Described by Text, and

229 MAPS

137 Route Maps, 71 City Maps, 19 Full Page Maps, 2 Double Page Maps.

SECTION No. 3

## New Jersey Pennsylvania South and West

478 PAGES

Size 5 1-2 x 9 1-2 inches

Covering New Jersey, Pennsylvania, Delaware, Maryland, and Trunk lines through the Middle West.

Containing 248 Routes, covering 16,983 miles of Roads

Fully Illustrated and Described by Text and

159 MAPS

65 Route Maps, 82 City Maps, 7 Full Page Maps, 5 Double Page Maps.

The most complete Volumes of Touring Information ever published.

All the Best and Most Popular Routes, and Best Accommodations in Hotels and Garages. Indispensable to Tourists. Bound in Genuine Leather, \$2.50 per Section, Prepaid. FOR SALE IN ALL LEADING BOOK STORES, GARAGES AND BY THE SOLE PUBLISHERS.

The AUTOMOBILE Flatiron Bldg., NEW YORK

Blue Book Dept.,

# MICHELIN

FRANCE, ENGLAND, ITALY, AMERICA.

Some motor car manufacturers and a good many AGENTS have not sold their cars. Not because the cars they built or sold were not powerful, fast, beautiful, roomy machines, for they were, but because these cars cost the owner so much to keep.

HIGH cost of up-keep is fatal to large and profitable sales. The largest item of up-keep cost is TIRE cost. The car owner who says "I went through an entire year on one set of tires" makes as many sales for the CAR he drove as for the make of tire he used.

Michelin's Tires reduce up-keep cost. They are famous the world over for durability and reliability. They are admittedly the Tire Standard of the world and EVERY MOTORIST KNOWS IT. Car buyers are DEMANDING Michelins today and GETTING them on their new cars. Agents are SPECIFYING Michelins and manufacturers—the able men of affairs who build the leading American cars—are EQUIPPING with Michelins.

MR. MANUFACTURER, how will your Agents sell their cars in 1908 in the face of competition which offers Michelins on cars of your price and class? You can AFFORD to equip with Michelins today. The public KNOWS it and your AGENTS know it.

See the Michelin Exhibit at the Importers' Salon. It is WORTH it.

MICHELIN TIRE CO., Milltown, N. J.

EXCLUSIVE

GREAT *Chadwick* SIXES

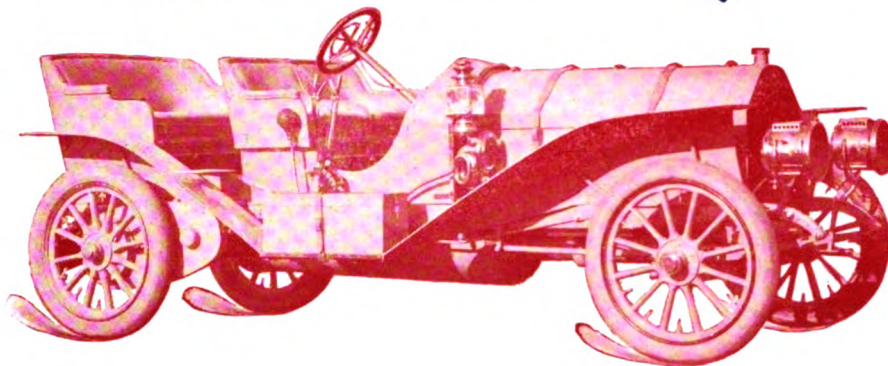

**\$5,500.00 Touring Cars**

**Tourabouts                      Runabouts**

It is becoming fashionable everywhere to own one. Only smart people of ample means can afford to buy one. Verily 'tis said that to him who hath shall be given.

A GREAT CHADWICK SIX is in reality the cheapest high-powered car for sale to the public. Notwithstanding the fact that it is easily the most powerful stock car built in the world, it will last and satisfy over a period of years, and its ability to go faster, to go slower, to always go and go more smoothly than any other motor car are facts we will prove by competitive tests.

If we could build CHADWICK SIXES better by putting into their cost of construction \$500 or \$1,000 more money, we would not hesitate to do so for an instant. The price would simply be advanced accordingly.

We will go further and state that THE GREAT CHADWICK SIX, in nimbleness and refinement, is as much superior to the so-called high grade American and European motor cars as the victorious motor boat "Irene" with its big CHADWICK motors compared to the old favorites which it so easily defeated for the International Cup and British Admiralty Trophy on the Hudson last September.

Ask any owner of a CHADWICK SIX about power and the control of it.

**Chadwick Engineering Works**  
**Spring Garden and 32d Streets**  
**Philadelphia and Pottstown, Pa.**

Agenies in the Large cities.



# Atlantic City, N.J.

World's Renowned Health Resort



## HOTEL RUDOLF

Largest and Most Modern Hotel on the Coast.  
Directly on Ocean Front and Beach Promenade.  
OPEN ALL THE YEAR.

New York's Favorite Location. All-year Seaside Resort. Capacity 1,000. American and European Plan. Rooms with Bath. Hot and Cold Sea and Fresh Water. Dining-room Overlooks the Ocean. The Finest Salt Water Bathing. Balmy Sea Air. Fishing and Sailing a Popular Pastime. Verandas of this Hotel Directly on Boardwalk.

SEND FOR BOOKLET AND RATES

A Special Feature of this Hotel is the reproduction of the celebrated "Harveys" cuisine.

JOEL HILLMAN, Proprietor, Atlantic City, N. J.  
Also Proprietor "Harveys" Famous Restaurant,  
Washington, D. C.

When in Washington Don't Fail to Try Harvey's Famous Sea Food and Game Specialties. Special Rates for Autumn and Winter Season.



THE TAMPA BAY HOTEL,  
TAMPA, FLA.

## The Land of Lovely Dreams

WHERE THE KNOTTED NORTHERN  
NERVES MAY RELAX AND REST

WHY should one go to Tampa rather than the resorts on the other coast of Florida? Because the climate of the west coast is far more equable, less enervating, more beneficial to nerves and mind than any other. The climate of Tampa is dry and its tropical warmth is tempered agreeably by westerly breezes from the Gulf of Mexico. While

the glorious sunshine in the day time reminds one of the close proximity of the tropical Everglades, night brings with it refreshing coolness and fragrant dews, and with them comes, without fail, "Nature's sweet restorer, balmy sleep." Apply to agents of The Seaboard Air Line Railway, The Atlantic Coast Railway, Southern Railway, and their connecting lines.

Booklet and Tariff sent on application.

DAVID LAUBER, Manager, Tampa, Florida



OPPOSITE THE FALLS

## Tower Hotel

The Home of the Brides

### Niagara Falls, N. Y.

European Plan, \$1.00 up.  
American Plan, \$2.50 up.

One Minute's walk from the Falls, directly opposite N. Y. State Park  
Special Rates to Large Parties

FREE. Enclose 5 cents in stamps to cover costs and I will send you one of the finest colored double postal cards ever gotten up of Niagara Falls, and it's a Beauty

M. J. HOENIG, Proprietor

## HOTEL WESTMINSTER

Irving Place and 16th St.,  
NEW YORK CITY

One block from UNION SQUARE, Surface, Elevated and Subway Cars. Midway between leading WHOLESALE and RETAIL STORES and THEATRES, and yet far enough from Broadway to insure COMFORT and FREEDOM from the noise and bustle of that thoroughfare. PERFECTLY QUIET locality and HOME-LIKE in every respect.

EXCELLENT CUISINE,  
EUROPEAN PLAN

Single Rooms, \$1.00 per day and up. Room with Bath, \$2.00 per day and up. Parlor, Bedroom and Bath, \$3.00 per day and up.

SEND FOR BOOKLET O. H. FOSTER, PROPRIETOR



## "ROYAL CROWN"

### AUTOMOBILE SOAP

Has Wonderful Cleaning Power and Preserves the Finish and Lustre.

CONTAINS NO FREE ALKALI.  
IS PURELY VEGETABLE. EASY TO USE  
The Only Genuine English Soft Oil Soap Sold in America



There are many so-called oil soaps on the market that look about the same as Crown Soap, but there is no other Oil Soap made in America that will clean so thoroughly and preserve the finish as long as "Crown Soap."

**CROWN METAL POLISH** Positively has no equal as a liquid metal polish, which makes it a time and money saver. Crown Metal Polish is the best automobile polish in the world. Money back if you don't agree with this statement after a fair trial. Upon receipt of 16c in stamps to pay postage, we will be pleased to send you a liberal sample for test.

MADE BY CROWN SOAP CO., SYRACUSE, N. Y.  
D. C. Longwill, 6 East St., San Francisco, Cal., Distributor for Pacific Coast.



STOP AT THE

## FREDONIA HOTEL

1321-1323 H Street, N.W.,  
WASHINGTON, D. C.

American plan \$2.00 per day and up. European plan \$1.00 per day and up. In the center of everything. Cuisine and service unsurpassed. Electric lighting. Modern improvements. Special rates to tourists and commercial travelers.  
SEND FOR BOOKLET.

WM. W. Danenhower, Prop.

# Veeder

"It's Nice to Know How Far You Go"

## Veeder Odometers

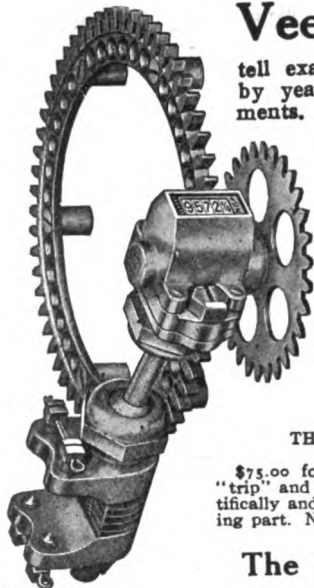

tell exactly. Universally used, tested by years of service. Don't try experiments. Buy a Veeder. Supplied in the following convenient forms for vehicles:

**FOR AUTOMOBILES:** From \$10.00 to \$20.00, with all fittings complete to attach to any make of car. Give size of wheel and model of car when ordering.

**FOR HORSE-DRAWN VEHICLES:** From \$3.50 to \$9.00, with fittings complete, for all vehicles and all wheel sizes. State size of wheel used.

**FOR BICYCLES AND MOTOR CYCLES:** Veeder Cyclometers from \$7.00 to \$2.50, ready to put on. Give wheel size.

### THE VEEDER TACHODOMETER

\$75.00 for automobiles, registers distance, both "trip" and total, and shows speed at all times. Scientifically and permanently accurate. Only one moving part. No Springs. Descriptive matter free from

**The Veeder Mfg. Company**

22 Sargeant St., Hartford, Conn.

Odometer for Automobiles.

## LOCKE & COMPANY AUTOMOBILE BODIES

¶ are now taking orders for early deliveries of Limousines, Landaulets, and other forms of closed bodies.

¶ Without parallel in this country or abroad.

¶ Combining extreme elegance, most refined designs and unexcelled durability.

¶ Not low in price, but the highest grade of work and finish that can be produced.

218-220 WEST 84th ST., NEW YORK

Telephone, 3258 Riverdale

# BREECH-BLOCK

## BETTER VALUE THAN ANY OTHER PLUG MADE

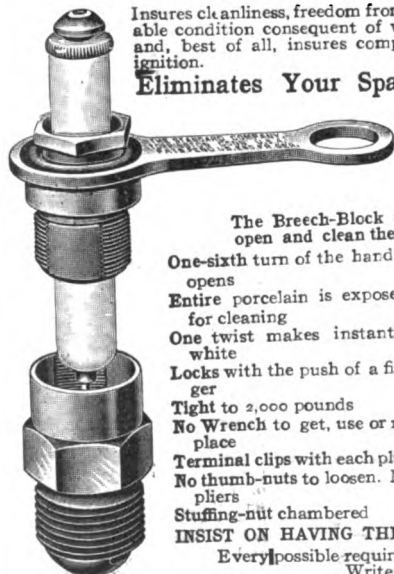

Insures cleanliness, freedom from the "fussed-up," uncomfortable condition consequent of working around a hot engine, and, best of all, insures comparative freedom from faulty ignition.

**Eliminates Your Sparking-Plug Troubles**

**SAVES TIME, TOOLS, TEMPER and TROUBLE**  
No other Plug possesses so many distinct advantages of value and efficiency.

The Breech-Block enables the operator to open and clean the plug in four seconds

One-sixth turn of the handle opens  
Entire porcelain is exposed for cleaning  
One twist makes instantly white  
Locks with the push of a finger  
Tight to 2,000 pounds  
No Wrench to get, use or replace  
Terminal clips with each plug  
No thumb-nuts to loosen. No pliers  
Stuffing-nut chambered

Plugs held by their handle in testing  
Not balanced on edge of your engine  
Soot-proof to the limit  
Unaffected by oil  
Chambered end protects porcelain  
Keeps porcelain fragments from cylinder  
Slightest piston movement cleans points  
Makes starting easy; fires first charge  
Big cars run slow on high gear  
Closely throttled; not a skip

**INSIST ON HAVING THE "BREECH-BLOCK" PLUG**  
Every possible requirement completely satisfied  
Write for booklet

**THE STANDARD CO., Torrington, Conn.**



## Edco Specialties

Manufactured by  
**ED. DUBIED & CO.**  
Couvet, Switzerland

**CH. DIEN**

Sole Importer  
45 W. 34th St. New York

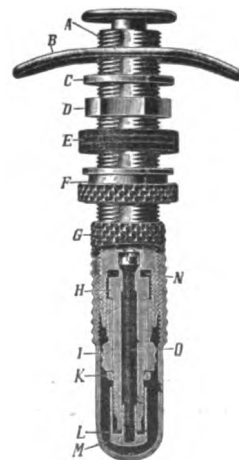

# The New Diamond Chrome-Nickel-Steel Chain

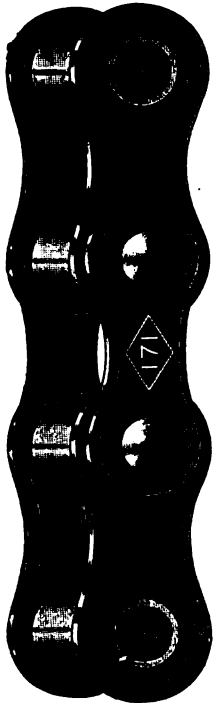

is the latest advance in the automobile industry. It is lighter than any other chain of equal width and pitch, but has greater tensile strength and safely does harder work.

The Chrome-nickel-steel side bars cushion severe blows from the engine without permanently stretching, and the tough and hard nickel-steel rivets resist wear better than any other material known for the purpose. That is why the pitch of Diamond Chains does not change.

All metal in Diamond Chains is made for us especially for use in chain parts. Our method of hardening makes rivets which positively will not crack nor break. Other facts about Diamond Chains are given in our book on "Chain Power Transmission," sent free on request.

**Diamond Chain & Mfg. Co.**

Capacity 8,000,000 ft. per year

230 W. Georgia St., Indianapolis, Ind.

*A wee bit more in price, but  
O, what a difference in the wearing!*

**FISK  
TIRES**

SAVE DOLLARS; SOMETIMES LIVES

**FISK Mechanically Fastened Tire**

The Only One in the World That Cannot Be Accidentally Pulled from the Rim

**Fisk Standard Clincher  
Fisk Quick Detachable**

New products, made for all rims  
Fisk Quality

**THE FISK RUBBER COMPANY, Chicopee Falls, Mass.**

Branches in all principal cities

# NON-FLUID OILS

## It is Friction — Not Work — That Wears Out Machinery

Perhaps you never thought of it that way before. Friction is simply lack of sufficient lubrication. Oiling the outside of a machine doesn't lubricate the bearings, but it's a fact that anybody can verify that most machinery needs wiping oftener than it needs oiling.

Grease isn't a wholly good lubricant because it demands frictional heat to soften it before it even begins to lubricate.

Logically and practically Non-Fluid Oils—"the oils which do not drip"—deserve their widespread recognition as the best known solution of the problem of cleanly, efficient and wholly economical lubrication.

Write for free samples or go to your dealer.

*Originators and  
Sole Manufacturers*

### New York and New Jersey Lubricant Co.

14-16 CHURCH ST., NEW YORK CITY



# REX STORAGE IGNITERS



Why buy old-fashioned batteries when you can get something from a reliable company at nearly the same price and containing the following improvements:

- 1st. The containing jar is made of hard and soft rubber vulcanized together, thereby minimizing the chance of breakage.
- 2d. The plates are made by ourselves and are guaranteed as to purity.
- 3d. The connections are made of hard rubber and non-corrosive metal.
- 4th. There are no metal parts to corrode.

Patents  
Applied  
For



New England Motor Co., Lowell, Mass.

Branch Offices: 163 Columbus Avenue, Boston  
253 Broadway, New York

## Smith Automobile Parts PRESSED STEEL FRAMES

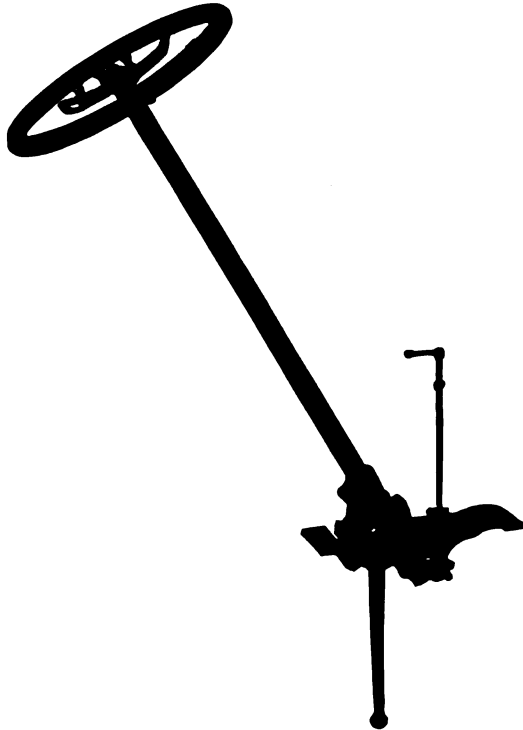

AXLES  
STEERING  
COLUMNS

TRANSMISSIONS  
STEEL  
STAMPINGS

**A. O. SMITH CO.**

247 Clinton Street Milwaukee, Wis.  
THE PIONEER MAKERS OF AUTOMOBILE PARTS

# SPEED CARBURETOR

OUR GUARANTEE  
IS EVIDENCE OF  
ITS SUPERIORITY

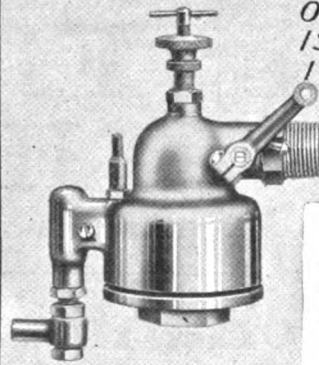

POSITIVELY  
GUARANTEED  
To Develop Greater  
**POWER, SPEED,  
FLEXIBILITY  
and ECONOMY**

In the engine than in any other Carburetor  
in the world, or purchase price refunded.

**Speed Changing Pulley Co.**

752 Washington Street,  
INDIANAPOLIS, IND.

TRY THE SPEED AT OUR RISK



**The  
Single  
Adjustment  
Holley  
Carburetor**

will be used on the 1908  
output of the following  
builders:

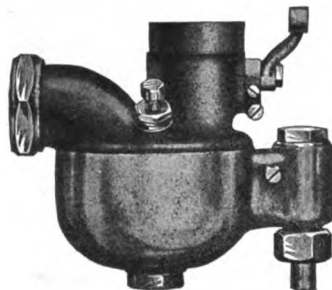

- MITCHELL MOTOR CAR COMPANY
  - OLDS MOTOR WORKS
  - T. B. JEFFERY & COMPANY
  - WAYNE AUTOMOBILE COMPANY
  - MOTOR CAR COMPANY
  - SMITH AUTOMOBILE COMPANY
  - BUCKEYE MANUFACTURING COMPANY
- Get a Holley and drive your car at a walk in high gear.

**HOLLEY BROTHERS CO., Detroit, Mich.**

- New England—Post & Lester Co., Hartford, Conn.
- Boston—Post & Lester Co., 821 Boylston St.
- Pacific Coast—Geo. P. Moore Co., 721 Golden Gate Ave., San Francisco, Cal.
- Geo. P. Moore Co., 1005 South Main St., Los Angeles, Cal.
- Geo. P. Moore Co., 231-233 Twelfth St., Oakland, Cal.
- New York—Chas. E. Miller, 97 Reade St.
- Philadelphia—Chas. E. Miller, 318-320 North Broad St.
- Pittsburgh—Kauffman Bros.
- Cleveland—Chas. E. Miller, 406 Erie St.
- Buffalo—Chas. E. Miller, 824 Main St.
- Centaur Motor Co., 53 Franklin St.
- Chicago—Excelsior Supply Co., 233 Randolph St.  
Beckley Ralston Co.
- Denver—Denver Auto Goods Co.
- Canada—John Forman, Montreal.
- Baltimore—Loane-Hiltz Engineering Co.
- Savannah—H. V. Connerat.

**WHAT'S THE USE  
OF CRANKING  
YOUR HEAD OFF ?**



**THE LOCKWOOD  
PRIMER**

**WILL START YOUR ENGINE  
THE COLDEST DAY  
BY SIMPLY TURNING OVER THE  
FIRST COMPRESSION.**

**WE KNOW THIS  
AND WILL GIVE ANY RESPONSIBLE  
PERSON 10 DAYS TRIAL ABSOLUTELY**

Price  
**\$5.00**

**FREE**

**RETURN IT AT OUR EXPENSE  
IF NOT SATISFIED.**

**SEND FOR CIRCULAR  
SEE WHAT OTHERS SAY**

**M'FG'D BY  
LOCKWOOD BROS.  
JACKSON,  
MICH.**



**Proof Against  
Wheel Accident**

**Indestructible  
Steel Wheels**

are the only absolutely safe, always reliable wheels for your runabout, touring car, wagon, or truck. They have been proven mechanically perfect by the severest test an automobile was ever subjected to. **Indestructible Steel Wheels** are the only wheels made that cannot collapse. They stand up under the most terrific strain from heavy loads, great speed and rough roads. Are in constant increasing use on commercial vehicles of all descriptions, Fire Patrols, and pleasure cars in cross-country touring. Everywhere that wheel strength is required.

**Indestructible Steel Wheels**

are stronger, lighter, faster, cleaner, truer, and cheaper than other wheels, and are being adopted throughout the country as standard equipment. Our open-pattern wheel is transparent when in motion and makes a handsome appearance on your pleasure car, as well as being proof against wheel accidents.

Write to-day for catalog and prices on a set of Indestructible Steel Wheels attached to the present hub and rim of your car.  
We make all kinds of Automobile Steel Stampings.

**INDESTRUCTIBLE STEEL WHEEL CO.**  
1304 Michigan Avenue CHICAGO

**SAVE STORAGE BILLS**

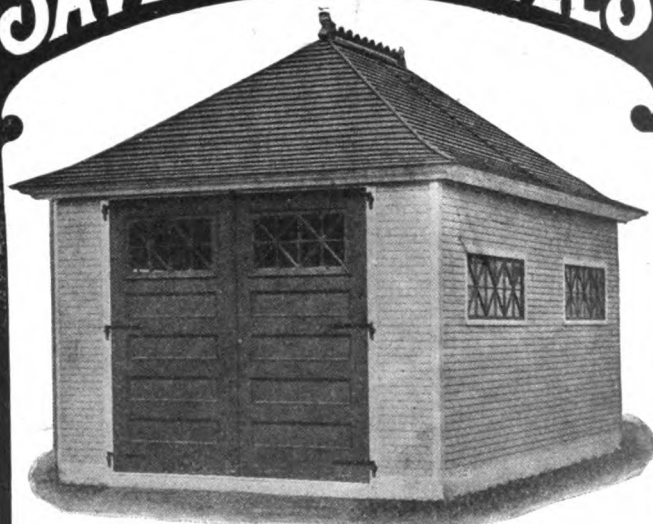

**—SAVED—**

Excessive garage charges, the long delays after ordering your car, the danger of fire and of unauthorized use by unscrupulous persons can be saved by having your own garage—on your own premises—

**SPRINGFIELD PORTABLE GARAGE**

A garage built along the lines of not how cheap, but how good. It houses your automobile safely and where it is free from the destructive odors of public garage or stable. You always have your car ready for instant use.  
Write for full particulars and prices.

**SPRINGFIELD PORTABLE HOUSE CO.**  
58 Waltham St. SPRINGFIELD, MASS.



*Phoebus*  
THE LAMP OF QUALITY

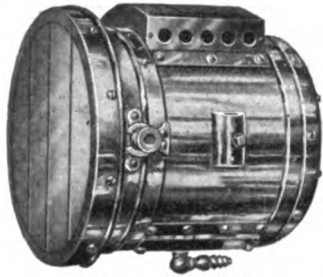

Every Autoist is Interested in that which Makes Good

**PHOEBUS LAMPS**  
Make Good

We sell our goods by telling the truth about them—we claim nothing exclusive unless it is exclusive. Certain makers of lamps state that a removable lens is an exclusive feature of their lamps, and yet both our front glass and back lens are removable. Perhaps it's a coincidence only? We have the same convenience on the PHOEBUS Lamps and a lot of other good features which NO other make of lamp embodies. We tell you fully in our catalogue what these features are—you can have one for the asking.

Our No. 202, illustrated above, is a standard. Extra heavy gauge brass, reinforced front and back, full size B & L Mangin Mirror, adjustable focus, extra heavy front glass.

**BEST LIGHT BEST BUILT BEST SERVICE**

**MANHATTAN SCREW AND STAMPING WORKS**

West End Avenue and 67th Street, NEW YORK

CONNECTICUT

**EXPLORING LAMPS**

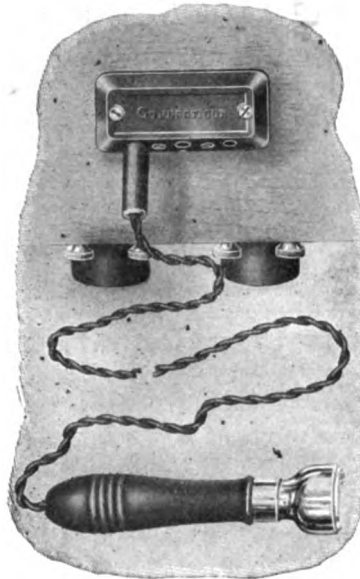

are perfectly safe "trouble finders." Fires without number have been caused by the motorist using matches or other kinds of lights when filling gasoline tanks or looking for leaks or other motor-car troubles. To get light, merely insert the plug of the

CONNECTICUT EXPLORING LAMP

in a plug switch.

Write for catalog 13B.

The Connecticut Telephone & Electric Co., Inc.  
50 Britannia Street, Meriden, Conn., U. S. A.

**TRUFFAULT-HARTFORD SHOCK ABSORBER**

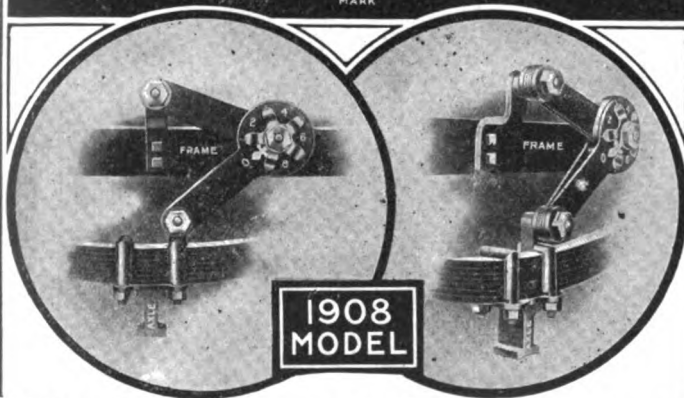

The Device that made Safe, Speedy and Comfortable Automobiling Possible

The spring action of a car affects its smooth running qualities. Proper control of the springs prevents excessive oscillation, which insures less wear and tear, longer life of tires, greater speed and genuine comfort

This control of the springs can be secured only by the use of the Truffault-Hartford Shock Absorber. The device that makes cobblestones and rough roads seem like asphalt. Write for Rough Road Booklet to Department G.

**HARTFORD SUSPENSION CO.**

E. V. HARTFORD, Pres. 64 Vestry Street, New York

**The Best Resolution You Can Make For 1908**

Is to refuse absolutely to accept "just as good" or "better" tires as substitutes for Morgan & Wright's.

**MORGAN & WRIGHT TIRES ARE GOOD TIRES**

All Styles of Treads.

**Morgan & Wright, Detroit**

Branches, Agencies or Dealers everywhere

"KEEP YOUR EYE ON CONTINENTALS."

# Continental TIRES

**"Ready-Flated" Tires.** These tires are the sensation of the season. They are carried already inflated on Continental Demountable Rims, ready for instant use in replacing a tire that is punctured. Exhibited at the Importers Salon, New York. Can also be seen at any of our branches or agencies or at dealers in motor supplies throughout the country.

**"Rouge-Ferre" (Anti-Skid).** This is the standard Anti-Skid Tire of the world. Steel studs with rivet heads are embedded in the tread during the process of manufacture, and are so firmly held in position that they cannot work loose or be torn out. Cars equipped with these tires are guaranteed not to skid under any conditions. These tires can be used in parks and on drives and boulevards where chains are prohibited by the local authorities.

**The Importers' Salon.** This exhibition, at Madison Square Garden, New York, is universally admitted to be the most beautiful and highest class display of automobiles ever given on the continent, the interior decorative effect of the Garden being a masterpiece of art, and the cars on display being valued at from \$3,500 to \$15,000 each.

On these magnificent cars there were more Continentals than any other tires.

**New Prices.** Continental Tires are offered this season on a new schedule of prices more favorable to the purchaser than any previously made by us. The immense volume of business that has come to us from our branches all over the world enables us to manufacture with greater economy without lowering the quality of the tires. Continentals are known as "the low cost per mile tires." They have a larger sale than any other tire which is some indication of the way they are regarded by motorists generally



## Continental Caoutchouc Company

JOE M. GILBERT, General Manager

43 WARREN STREET, NEW YORK

### BRANCHES

Buffalo: 729 Main Street.

Detroit: 226 Jefferson Avenue.

New York City: 2100 Broadway

San Francisco: 422-424 Van Ness Avenue

### DISTRIBUTING AGENTS

Continental Agency Co., 1268 Euclid Ave., Cleveland, Ohio.

James L. Gibney & Bro., 211 N. Broad St., Philadelphia, Pa.

Neustadt Automobile and Supply Co., 3948 Olive St., St. Louis, Mo.

Plant Rubber Co., 322 1st Ave., North Minneapolis, Minn.

Revere Rubber Co., 700 Baronne St., New Orleans, La.

The Post & Lester Co., 821 Boylston Street, Boston, Mass.

Western Continental Caoutchouc Co., 1438 Michigan Avenue, Chicago, Ill.

NEW

*Neverout*

IDEA

**Double Focus Searchlight**

PATENT APPLIED FOR

New York Branch:  
107 Chambers Street.

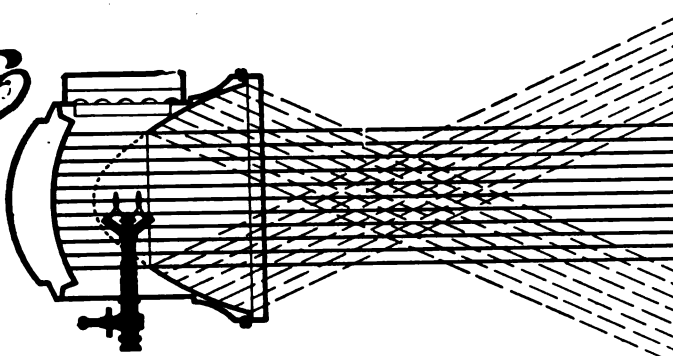

Twice as Powerful as the Old Fashioned Kind

**The Most Powerful Gas Searchlight Ever Produced.**

**Two Gas Flames, Two Reflectors.**

Write for free booklet, also describing the Neverout Patent Invertible Safety Gas Producer

**ROSE MANUFACTURING COMPANY**

Main Office: 906 Arch St.  
PHILADELPHIA, U. S. A.

**The Practical Gas Engineer**

What It Is and How To Do It. A book of 150 pages neatly bound in cloth. Sent post-paid for \$1. Address Book Department, The Automobile, Flatiron Building, New York.

**HOLSMAN RECORDS**

**THE CAR WITH A REPUTATION!**  
**5 YEARS OF SUCCESS!**

The records of the participation of the Holsman Automobile in public contests date back to 1903 when it won a blue ribbon in the Chicago 100-mile Reliability Run of that year.

Some of the more recent records are:

*Chicago 100-mile Reliability Run, July 26, 1906:*  
Perfect score in runabout class and first place in touring cars in our class.

*Algonquin Hill Climbing Contest, Sept. 6, 1906:*  
Making better time than machines of nearly double the price.

*Algonquin Hill Climbing Contest, Aug. 9, 1907:*  
Fastest time in its class.

*Chicago 150-mile Reliability Non-Motor-Stop Run, June 28, 1907:*  
Perfect score.

*Chicago 95-mile Fuel Economy Contest, Sept. 13, 1907:*

Smallest gasoline consumption, with one exception; 29 miles per gallon.



**The Holsman Automobile Company**

The Oldest and Largest Manufacturers of High-Wheeled Automobiles.

Room 413, Monadnock Block, Chicago, Ill.

**Auto Fronts and Tops**

**COL. SPRAGUE'S NEW 1908 COMMON SENSE GOODS FOR SENSIBLE PEOPLE**

A gentleman's outfit. One in one, that's all. We kill the bugs—we don't catch 'em and hold 'em. They are fool proof. No set screws. No plunge bolts. No other rattle traps or monkey shines.

*Simplicity, Durability and Elegance*

All the working parts made of phosphor bronze and can't break.

Ask for our catalogue and price list

**THE SPRAGUE UMBRELLA CO., Norwalk, O**

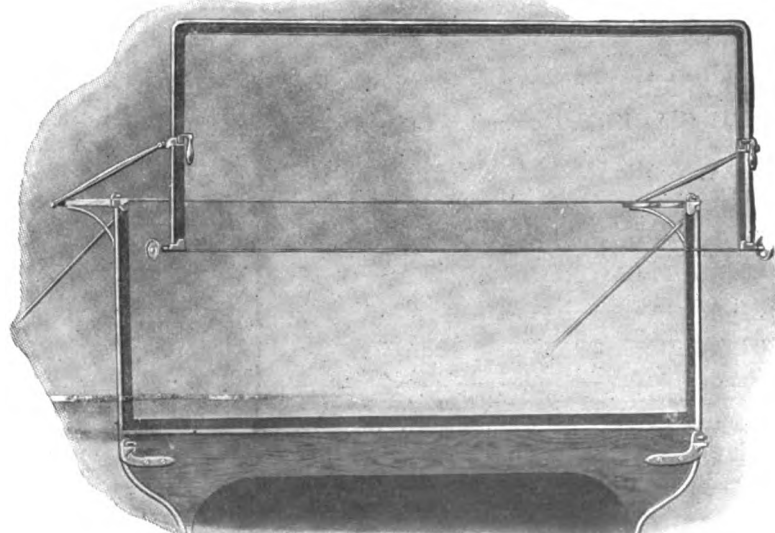



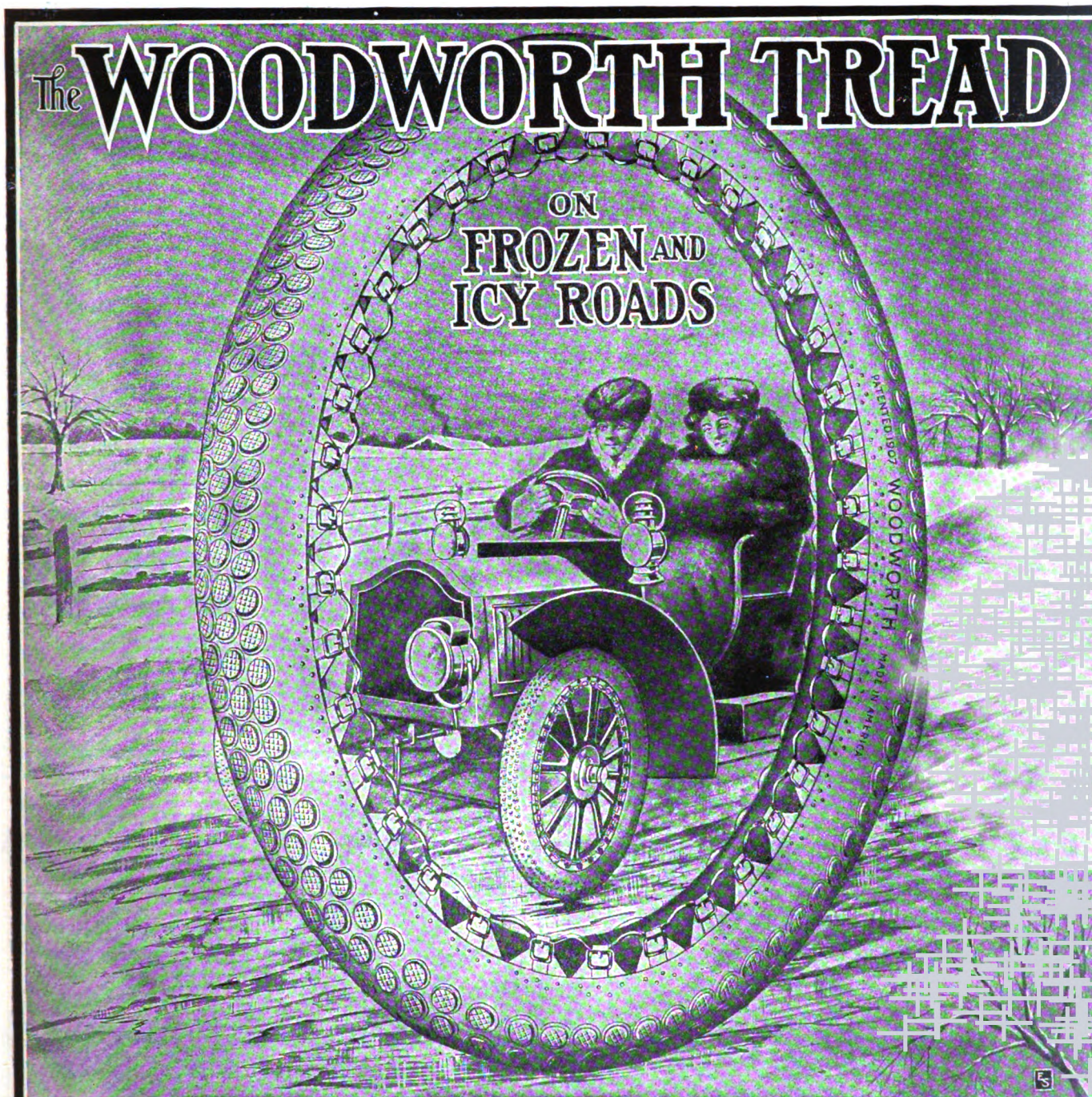

**RAN WOODWORTH TREADS DURING ENTIRE WINTER**

"Ran car equipped with Woodworth Treads during entire winter 1906-'07, on frozen ground and ice."—E. D. MOREY, Clinton, Mass.

**USED 1,000 MILES, LARGELY ON ICE, AND STILL GOOD**

"Put Woodworth Treads on old tires that were in bad shape, almost worn out. Ran over 1,000 miles three months in the winter, on ice, largely. They are still good. I'll use them some more."—OLIVER CROSBY, St. Paul, Minn.

**500 MILES OVER ROUGH, ROCKY MOUNTAIN ROADS**

"Ran my 6-cylinder 'National' with Woodworth Treads on the rear wheels 500 miles over rough, rocky, mountain roads in Northern California, and rear treads and tires were O. K., while the front tires, which had no covers, were ruined. Can't recommend your treads too highly."—C. L. BEST, San Leandro, Cal.

Woodworth Treads are made in sizes 26 x 2½ to 36 x 5. Prices, \$8.00 to \$25.00 each  
Prices for Special Woodworth Treads for Ruddy Roads are 20 per cent. higher than the above

Write for handsome booklets, "Safe and Sane Automobiling," and "Trail of the Woodworth Tread." Free. Address

**LEATHER TIRE GOODS CO., NEWTON UPPER FALLS, MASS.**  
New York Store, 1662 Broadway





MODEL 6 VICTORIA—PRICE \$1,700

**SENSE OF SECURITY**

Is Enjoyed When Riding in

**BABCOCK ELECTRICS**

Eight Years on the Market and Still Growing in Popularity. Accidents are impossible with:

**BABCOCK ELECTRICS**

"When you build right, it is right and works right."—Babcock

FIVE MODELS

WRITE FOR CATALOGUE

**Babcock Electric Carriage Co.**

BUILDERS

232 West Utica Street, Buffalo, N. Y.

New York Branch: 1591 Broadway, cor. 48th St.



BUILT IN THE HILLS

WE USE THE FAMOUS  
**RUTENBER**  
40 H.P. MOTOR

*The Glide*  
AUTOMOBILE

\$2,500

**GLIDE PRICE IS THE MEASURE OF REAL CAR VALUE**

Why pay more—except to satisfy price pride? If you do, what do you get for your money?

Motor—Selective Transmission, nor axles waste any power, therefore a Showing is made on hills in speed and through mud or sand.

Reliability has been established by owners touring from state to state, across the continent and in Europe. Our large gears defy breakage. Roller bearings eliminate friction. Continued satisfactory service is the result.

A car of comfort and perfect control. Write for catalog.  
**THE BARTHOLOMEW CO., 235 GLIDE ST., PEORIA, ILL.**

3 TON

5 TON

**"AMERICAN"**

**TRUCKS**

"WE DELIVER THE GOODS"

WRITE US

**AMERICAN MOTOR TRUCK CO.**  
LOCKPORT, NEW YORK

**WELCH**

"The most EFFICIENT Car"

4 Cyl

50 H.P.

**WELCH MOTOR CAR CO.**

PONTIAC, MICH.

*Studebaker*

A car that has quietly taken its place among the leaders

**STUDEBAKER AUTO CO.**

SO. BEND, IND.

General Office, Cleveland, Ohio

**THE GARFORD COMPANY, Elyria, Ohio**



Parts for Power Wagons.

Heavy and Light Electric or Gasoline.

Equipment "L" makes the best Light Electric Delivery yet produced

Sold by THE AMERICAN DISTRIBUTING CO., American Trust Bldg. CLEVELAND, OHIO.

Owning of the Full-Jeweled



includes the certainty of constant, efficient service at a remarkably low cost of maintenance.

Advance Catalogue upon request.

**CORBIN MOTOR VEHICLE CORPORATION**

Member Association Licensed Automobile Manufacturers

NEW BRITAIN CONNECTICUT  
1888 Broadway, 62d Street, New York

AGENTS and DEALERS

Get acquainted *now* with

*The*  
**Aurora**

**RUNABOUT**

*"Built for Nothing but Service"*

18-20 H.P., water cooled, with either solid or pneumatic tires at

**\$700 and \$775**

*Catalogues and Specifications from*

THE  
**AURORA MOTOR WORKS**  
AURORA, ILL.

**The Auto Car Equipment Co.**

**Make the Highest Powered  
Limousines in the  
Market**



6-Cyl., 60-H.P., Seating 7 to 10 People. *Elegant, Luxurious.*

Also Manufacturers of

**Trucks, Omnibuses and Sight-  
Seeing Cars—Gasoline and Electric**

ADDRESS

**THE AUTO CAR EQUIPMENT CO.**  
87 Edward Street, Buffalo, New York

**A New**

**Columbia**

**7 Passenger Motor Car  
with Electric Transmission**

**E**LECTRICITY is not a prime power agent, yet as a means of transmission and control of power it has supplanted all other methods in steam railroads, street railroads, warships, factories, etc., and in the new high-powered 7 passenger gasoline car electricity has supplanted all friction clutch, gear boxes and shifting levers

Also the light Columbia touring car, runabout and limousine has many and important improvements for 1908

**ELECTRIC VEHICLE CO., Hartford, Conn.**  
*Member A. L. A. M.*

**NEW YORK: 134-136-138 West 39th Street**

**The Invincible Schacht**

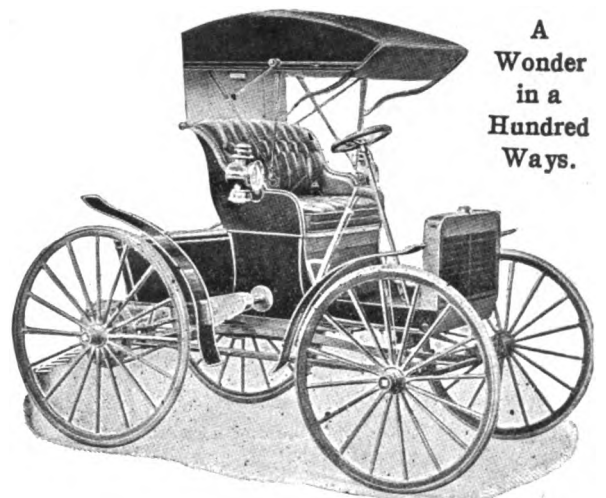

A  
Wonder  
in a  
Hundred  
Ways.

The simplest, most practical, efficient and economical car ever built. Twelve H.P. Friction Drive. Any speed up to 30 miles per hour. All parts interchangeable and thoroughly "getatable." Large wheels with cushion tires overcome all tire troubles. Almost noiseless and rides like a pneumatic. The greatest selling proposition on the market. Live agents wanted everywhere. Prompt deliveries and thorough satisfaction guaranteed. Send at once for catalogue, etc., and be convinced.

**The SCHACHT MFG. CO., Cincinnati, O.**

# GEARLESS "GREAT SIX" The Greatest Proposition on Wheels

**MODEL**  
75

**PRICE**  
\$4,000

**HORSE**  
**POWER**  
75

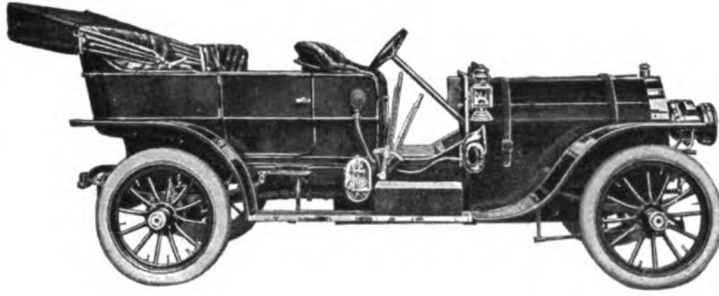

One of the most convincing arguments as to the reliability and proven worth of Gearless Cars is the fact that we have found it unnecessary to make any radical changes from our 1907 models. Such changes as have been made apply to the refinement of minor details, to which the progressive manufacturer is always keenly alive.

*Catalogue tells it all. Write*

**Gearless Transmission Co.**

(Motor Car Dept.)

295 PLYMOUTH AVE., ROCHESTER, N. Y.

# WESTON ELECTRICAL INSTRUMENT CO.

## Electrical Measuring Instruments

FOR USE IN

Electrical Carriages and in Charging Stations

Send for Catalogue

Main Office and Works, Waverly Park, Newark, N. J.  
New York Office, - - - 74 Cortlandt Street

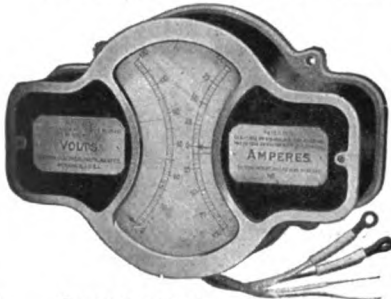

Combination Volt and Ammeter  
Model 30



Switchboard Instrument  
Model 24

# TINCHER MOTOR CAR CO.

SOUTH BEND, IND.

Chicago Branch—Chicago Automobile Club

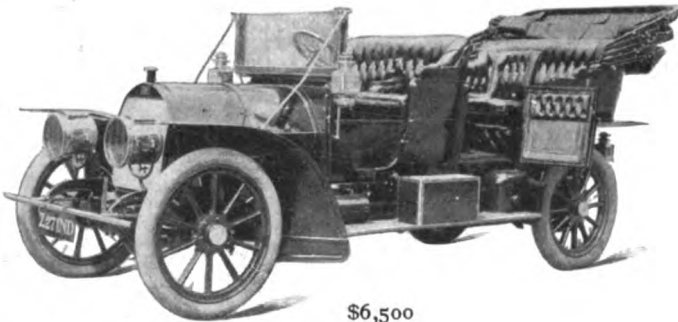

\$6,500



# NONPAREIL

Ten Styles of Horns.

Ask your dealer for "Nonpareil Horns." Beware of "cheap imitations." Get the best. Will refer to the principal auto manufacturers and to the leading jobbers.

**AUTOMOBILE SUPPLY**  
**MFG. CO.** 139-147 EMERSON PLACE  
BROOKLYN, N.Y.

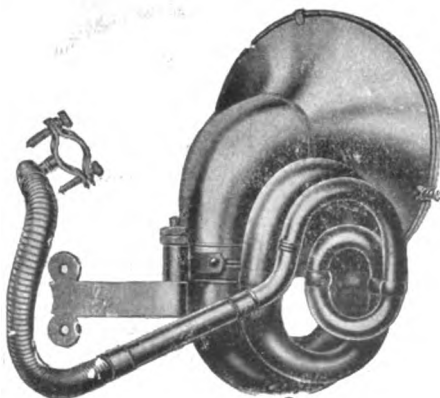

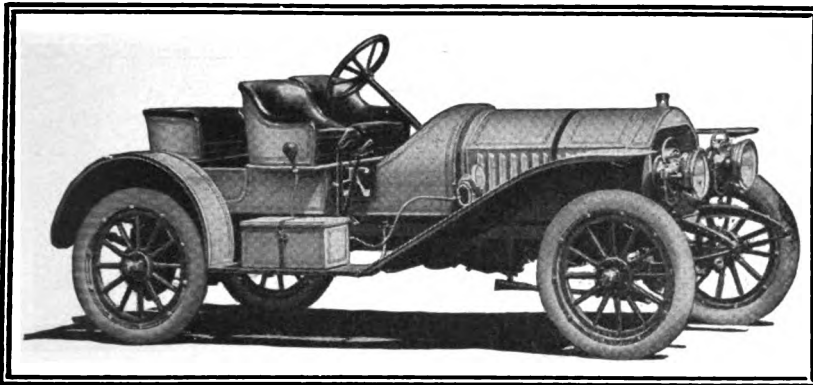

MILE A MINUTE AUTOCAR ROADSTER, 30-35 H. P., Fully Equipped, \$2,750

# The Autocar

Type XIV Touring Car, 30 H. P.	- - -	\$2,750
Type XV Runabout, fully equipped	- - -	1,200
Limousine	- - -	3,750

IT PAYS TO KNOW THE AUTOCAR

## The Autocar Company

ARDMORE, - - PA.

Write Department T for "AUTOCAR LIFE" and Catalogue

1908

# Locomobile

Combines Proved Reliability with Increased Efficiency and Low Cost of Up-Keep

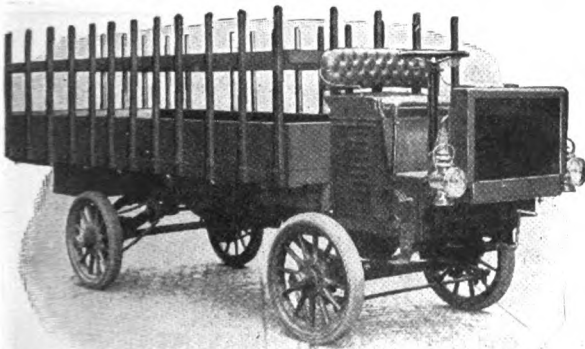

## Reliance 1908 Detroit

DO YOU KNOW we are today *building* and *selling*

- TWO-CYLINDER, 2 to 2½ ton trucks,
- THREE-CYLINDER, 3 ton trucks,
- FOUR-CYLINDER, 4 ton trucks,

EACH capable of a 25% OVERLOAD? These three sizes constitute the ONLY capacities for ECONOMICAL trucking. Ask for catalogue and prices. *Reliable agents wanted.*

RELIANCE MOTOR CAR CO., Detroit, Mich.

FAMOUS

# Apperson



KOKOMO INDIANA



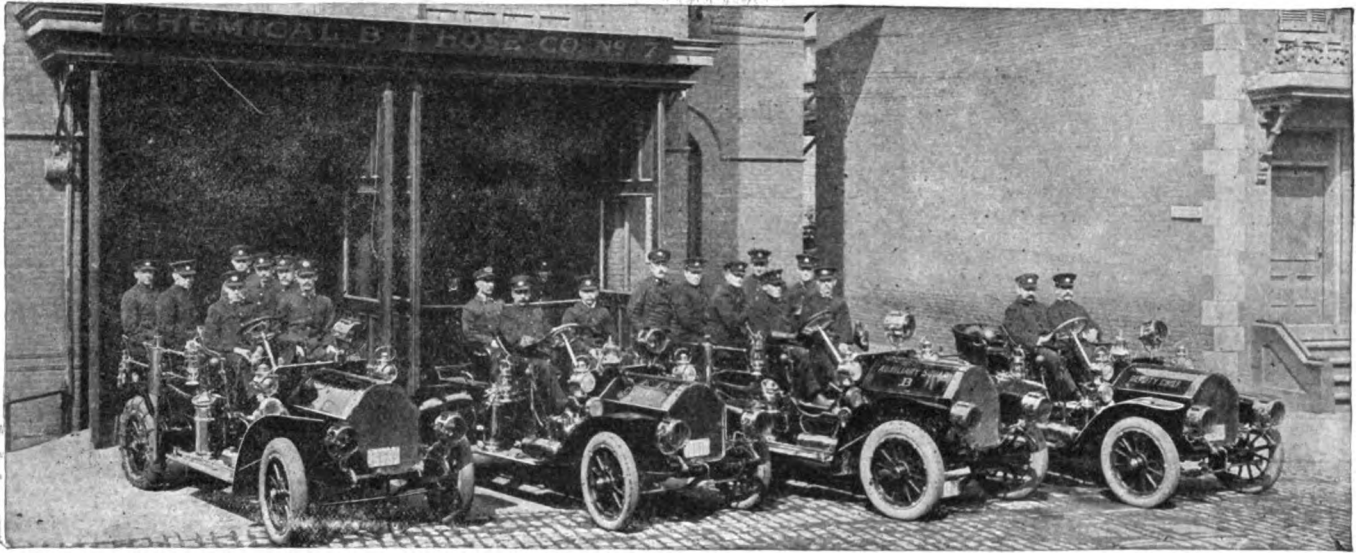

GROUP OF KNOX MOTOR FIRE WAGONS USED AT SPRINGFIELD, MASS.

## WHEN FIGHTING A FIRE

an ounce of fact is worth a ton of assertion.

When you see a picture of a motor fire wagon, look at the lamps. It's about ten to one they're Rushmores. The RUSHMORE STANDARD Lens Mirror is as far ahead of the Navy Standard as the Navy Standard is ahead of what you'll find in the average auto lamp. That means a lot when you're in a hurry.

**Rushmore Dynamo Works, Plainfield, N. J.**  
**LONDON** **PARIS** **CHICAGO**

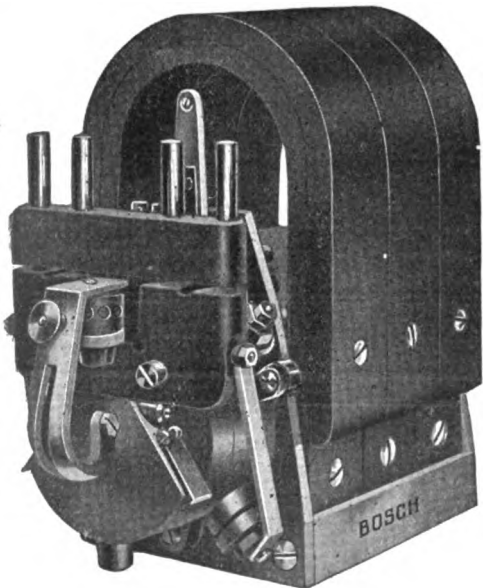

## 49 OUT OF 50 AT SEMMERING!

At the Semmering Hill Climb, Austria, in five events there were fifty starting Cars

**49 of These Were Equipped  
With Bosch Magnetos**

What does this demonstrate? 49 out of 50 Cars had **perfect Ignition**. And the "lonesome" Car was in good company.

**ROBERT BOSCH, NEW YORK, Inc.,**  
**160 WEST 56th STREET, NEW YORK**

*"You  
Get  
What  
You  
Pay  
For."*

When we began the manufacturing of speed indicators we promised ourselves that quality should rule above all other considerations. That promise has never been broken. We believed then, as we do now, that quality and honesty and fair dealing could be made to pay dividends. How well that belief has been borne out is best told by the fact that

# The Warner Auto-Meter

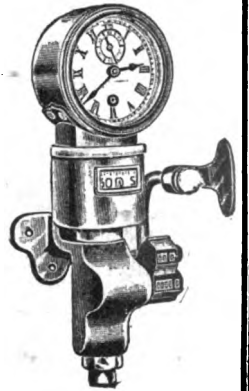

was on 70 per cent of the Glidden Tour 1907 contesting cars and on 60 per cent of the cars entered in the Glidden 1906 Tour. That the Warner Magnetic principle of speed indication is the only one is proved by the fact that it has been adopted by the United States Government to show the velocity of the wind. Uncle Sam wants the best—a poor speed indicator is worse than none—he knows that he can't get a reliable one for less than the Warner price.

*Write for Complete Information.*

*Warner*

The Warner Instrument Co. 821 Roosevelt Avenue Beloit, Wis.

**T  
I  
M  
K  
E  
N**

**55%**

**55%**

**55%**

of all the Exhibitors of both pleasure and commercial cars at the great Chicago Shows held in the Coliseum Annex, 1st Regiment Armory and Tattersalls 7th Regiment Armory are using

### TIMKEN ROLLER BEARINGS OR AXLES.

When you consider the varied exhibits and large number of individual Exhibitors, this showing is most remarkable—yet it shows that more than half of them are of one mind, notwithstanding the fact that price is always secondary to quality with TIMKEN PRODUCTS.

In the great 3 day Chicago Reliability Run a HAYNES car WITH WHEEL HUB SEALED carried off the prize with a clean score. Some say a practical impossibility with bearings not of

### THE TIMKEN PRINCIPLE AND QUALITY.

If you are not using TIMKEN PRODUCTS, write us—we have facts to present that not only mean profit, but reputation to you.

**THE TIMKEN ROLLER BEARING AXLE CO.**  
CANTON, OHIO

Eastern Branch—10 E. 31st St., NEW YORK

Western Branch—429 Wabash Ave., CHICAGO

# Cleveland

The 1908

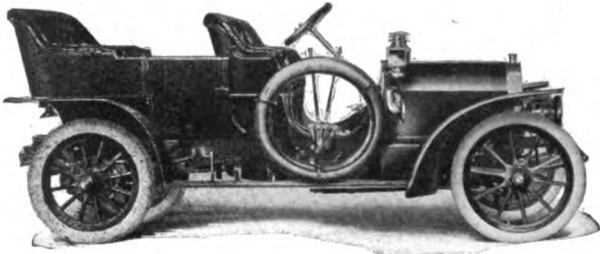

40-45 H. P.  
AT  
\$3,500

presents more really remarkable features than you will find in any other car now offered, no matter its country or price.

¶ There isn't a detail that a perfect car should have that is *missing* from 1908 Cleveland. There isn't a detail that is unworthy of absolute motor car perfection that is *present* in the 1908 Cleveland. Every feature could be made a special "selling feature."

¶ Such features, for instance, as ignition, lubrication, brakes, and a novel ratchet-sprag, you will find distinctively new. But its many features are so notably in advance of any car so far built that you will have to examine it in detail to appreciate its intrinsic merit.

¶ And just consider for a moment the extraordinarily low price at which this 40-45 H. P. Cleveland is offered.

¶ If you are not sure just what dealer is handling this car nearest to your home, just drop us a line and we will immediately advise you of his name and address, and enclose a request that he furnish you with a complete demonstration at your best convenience.

¶ If you are a dealer, and have not yet gotten into communication with us concerning this 1908 Cleveland—get busy! It is bound to be the selling sensation of 1908.

**CLEVELAND MOTOR CAR COMPANY**

GENERAL OFFICES AND SALESROOMS:  
1659 Broadway, New York City

# Stevens-Duryea Six-Cylinder Automobiles

The wise automobile buyer will purchase a six-cylinder car if he desires a horse power of forty or over, or pays more than \$2,750. The six-cylinder car has so thoroughly demonstrated its great superiority over the high-powered Four that the latter type of car is being built by fewer manufacturers each succeeding year.

Six cylinders are absolutely necessary if you are to derive the maximum amount of pleasure in motoring.

It is obvious, however, that but few manufacturers are experienced builders of Sixes, inasmuch as the majority of manufacturers held back until they were forced to build Sixes. The Stevens-Duryea Company were the six-cylinder pioneers in America. The design of the Stevens-Duryea Big Six, which scored an instant and unqualified success, was being worked out a year before the first car was built in 1905. Hundreds of Stevens-Duryea Sixes were in use and giving satisfaction when manufacturers generally were starting to build Sixes.

The famous Stevens-Duryea Unit Power Plant and Three Point Support insure perfect alignment always, lighter weight and extreme simplicity and durability. Its six cylinders mean perfect control, quiet running and absence of vibration.

Don't purchase an experiment simply because it is a Six-cylinder car. Select a car that is a known quantity. Stevens-Duryea Sixes have been a known quantity since 1905.

Model U—Light Six.....	\$3,500
Model U—Light Six Limousine.....	4,500
Model S—Big Six.....	6,000
Model R—Limousine.....	3,300
Model X—Four-cylinder.....	2,750

## STEVENS-DURYEA CO.

Chicopee Falls, Mass.

MEMBER A. L. A. M.



# The Car You Can Afford to Buy and Keep

is the Mitchell.

—Because it is moderate in price (\$1000 to \$2800).

—Just as stylish, handsome and well finished as any car.

—And is perfect in each detail of construction.

—Doing just as well on the road and standing up to wear and tear just as well as the extravagantly high-priced cars.

Know this for yourself, Mr. Business Man.

Get demonstrations of the high-priced cars.

Then form your opinion in a demonstration of the Mitchell.

The Mitchell agent will be glad to take you out for 50 or 100 miles any day.

Call him up—you are placed under no obligation.



# \$2000

*Just say "Show me"*

He'll answer with the car—show you a "silent argument" that will convince you.

Write for letters proving that the Mitchell is the most economical car to operate, and for catalog No. 18, picturing and describing the Mitchell Touring Car, \$2000, Limousine, \$2800, Roadster \$1250 and Runabout \$1000.

Touring Car shown here—5 passenger, 35 h.p., 4-cylinder, speed 50 miles, finished in Mitchell blue—a very neat and extremely desirable car from radiator to tail light.

Mitchell Motor Car Co., 303 Mitchell St., Racine, Wis.

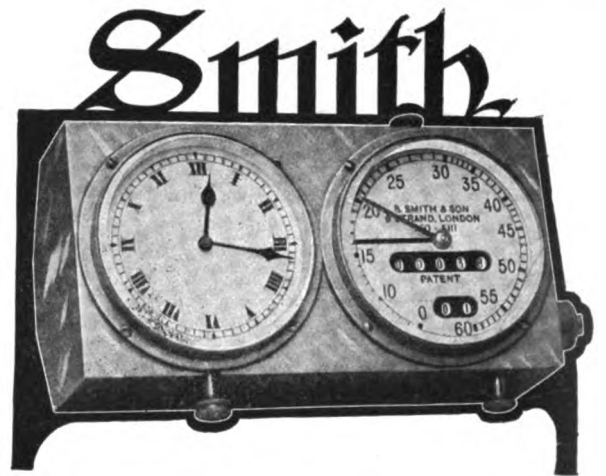
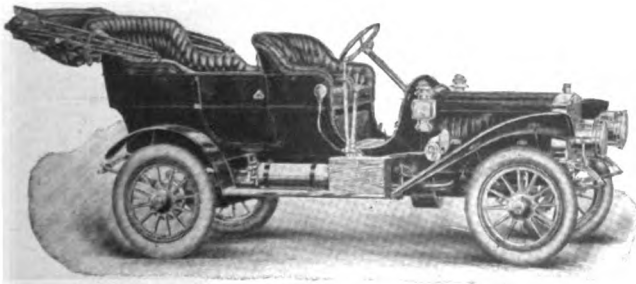

## ENGLISH Speed Indicators

"Smith" Speed Indicators are worth the slightly higher price because they are

### More Accurate and Sensitive

at all speeds on account of the hand workmanship and the three-spring governor.

### More Reliable

because of the slow revolution of the driving shaft and the use of friction drive instead of exposed cogs.

### More Convenient

because they are made both singly and in many combinations (see Type 5 above), with eight-day clocks, communicators, compasses, barometers, etc.

Catalogue on request. Dealers wanted.

New models and new prices at our exhibit at the Importers' Salon.

**S. SMITH & SON, Ltd.**  
DEPARTMENT D  
116 BROAD STREET, NEW YORK



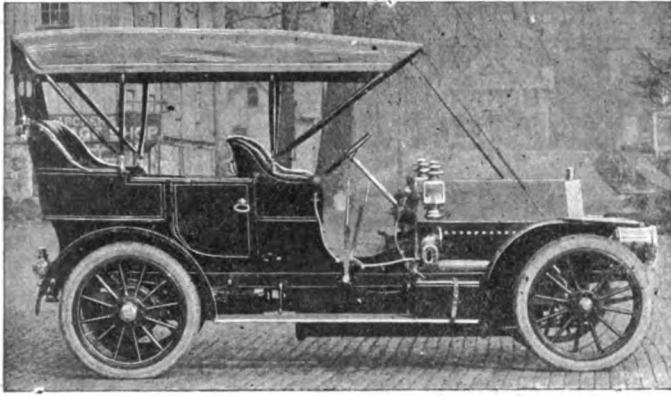

## The One Topic of Automobile Talk

The newest and best development of 1908 models embodying numerous novel and interesting features deserving of special attention.

### Highest Quality, Moderate Price

Cost of Up-Keep Reduced to a Minimum

#### SPECIFICATIONS:

Motor—Rutenber, 4-cylinder  
Bore—4 3/4 inch  
Stroke—5 inch  
H.P.—40 at 1000 R.P.M.  
Transmission—Selective type,  
Sliding gear  
Speeds—Three forward and  
reverse

Bearings—Timken Roller  
Wheels—36 inch  
Tires—4 inch, any make  
Wheel Base—117 inch  
Tread—56 inch

Body—Touring with seats for  
7 passengers  
Front Axle—1 piece drop forg-  
ing, I-beam section  
Rear Axle—Clutch driven, float-  
ing type  
Frame—Pressed steel

**DON'T FAIL TO GET FULL PARTICULARS IMMEDIATELY**

**FOREST CITY MOTOR CAR CO.,**

**136 WALNUT STREET  
MASSILLON, OHIO**

Agents Wanted in Unoccupied Territory. Write To-Day

# The "JEWELL"

## National Motor Cars

### "THE ALL BALL-BEARING CARS"

The 1908 line consists of Two 4-Cylinder and Two 6-Cylinder Models in Touring Cars, Limousines and Roadsters, each equipped with National Ball-bearing Motors.

The entire line embodies the tried and proven National type of construction, refined and perfected in all details to the highest possible degree.

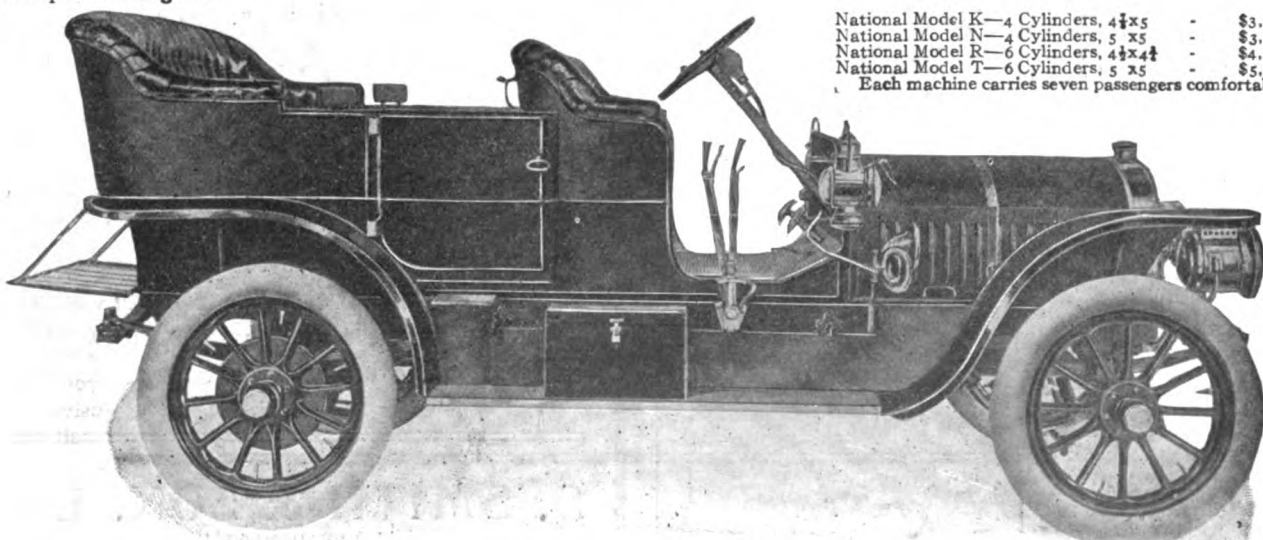

National Model K—4 Cylinders, 4 1/2 x 5	-	\$3,500.00
National Model N—4 Cylinders, 5 x 5	-	\$3,700.00
National Model R—6 Cylinders, 4 1/2 x 4 1/2	-	\$4,200.00
National Model T—6 Cylinders, 5 x 5	-	\$5,000.00

Each machine carries seven passengers comfortably.

WRITE FOR DESCRIPTIVE MATTER

**National Motor Vehicle Company**



**Indianapolis, Ind.**

# KINGSTON CARBURETERS

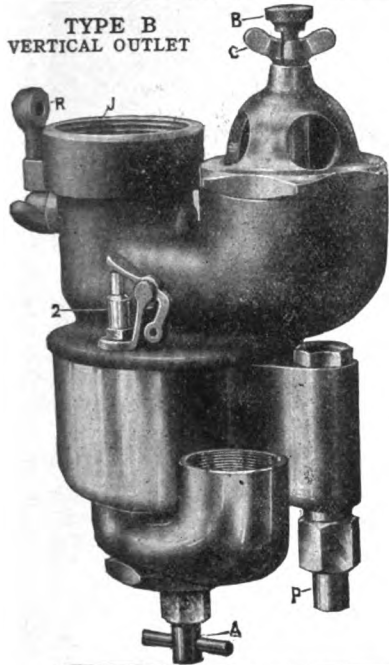

**S**HOULD be the regular equipment of every car; good results require a good Carbureter. "Kingston" Carbureters insure reliable carburetion—a uniform and perfect mixture, ALWAYS. They meet all running conditions most satisfactorily and are most durable and economical. Owing to their all-round perfection they have gained a most extensive popularity in all parts of the world.

## Over 77,000 Now in Use

The 1908 line consists of eight different types to meet every possible requirement. They are the same dependable, efficient Carbureters of quality they have been for years, changing only in new features and improvements as new conditions demand.

"Kingston" Carbureter on a car is a small thing to look for, but a big thing to find, for it guarantees that so far as Carburetion is concerned it is the most reliable car in the world.

## Insist on "Kingston"

Sold by leading jobbers throughout the United States. Send for special descriptive Catalog.

# BYRNE, KINGSTON & CO., KOKOMO, IND., U.S.A.

Eastern Distributor—CHAS. E. MILLER, 97 Reade St., New York City    Canada Distributor—JOHN MILLEN & SON, Toronto and Montreal

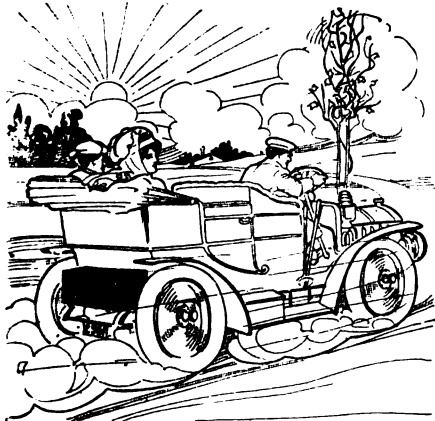

# JOHN BOYLE TRUNK

OF INESTIMABLE  
CONVENIENCE TO  
AUTOMOBILISTS

GIVES STYLE AND FINER  
APPEARANCE TO YOUR CAR



**Y**OU start out in the morning with the sun ashining and end the tour in the rain, sleet or snow. With a John Boyle Trunk you can provide for any emergency.

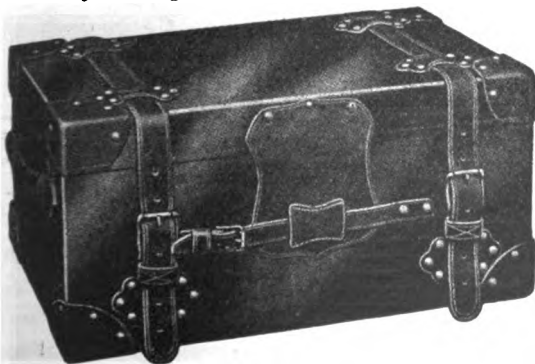

You can carry all requirements of clothing and other necessities for your family and self in one roomy, safe, sure—under lock and key—water-proof and dust-proof trunk, strapped out of your way at the rear of the car. You are always ready for any emergency, regardless of the wind and the weather or stop-overs en tour. Easily opened en route. At your destination unstrap from car and send into your rooms. John Boyle & Co.'s trunks have a style and quality exclusively their own—none of the imitations approach them in any way, and their quality of material and construction makes them almost everlasting.

Write for Style Book and Prices for the various makes of cars

**John Boyle & Co.** 112-114 Duane St. 70-72 Reade St. New York



**“SCHEBLER” CARBURETER IS TIME-TRIED  
AND FOUND SUPERIOR IN EFFICIENCY AND ECONOMY**

Always reliable regardless of engine speeds or atmospheric conditions, giving a perfect and uniform mixture, always, and increasing the power of your engine twenty to thirty per cent. Whether you are a manufacturer of motor cars or an individual owner, “SCHEBLER” Carbureter must have your consideration if you want THE BEST.

**WHEELER & SCHEBLER, Manufacturers**  
Factory: INDIANAPOLIS, IND.

**SALES OFFICES**

F. J. ALVIN, Mgr.

333-337 Randolph St., Chicago.

**NEW ENGLAND OFFICE**

W. J. CONNELL, Mgr.

36 Columbus Ave., Boston, Mass.

**EASTERN OFFICE**

E. J. EDMOND, Mgr.

The Motor Mart, 62d and Broadway, N. Y.

**CANADIAN OFFICE—JOHN MILLEN & SONS, Ltd., Montreal—Vancouver—Toronto.**

**LIST OF DISTRIBUTORS**

**EXCELSIOR SUPPLY CO.**, Exclusive Agents for Chicago and Cook County, Ill.  
**Pope Manufacturing Co.**, Hartford, Conn.  
**The Kelsey Co.**, Buffalo, N. Y.  
**Chas. E. Miller**, 824 Main St., Buffalo, N. Y.  
**Chas. E. Miller**, 406 Erie St., Cleveland, Ohio.  
**Chas. E. Miller**, 227 1-2 Jefferson Ave., Detroit, Mich.  
**E. B. Belcher**, 26 Green St., Malden, Mass.  
**Hub Automobile Exchange**, Dorchester, Mass.  
**National Elec. Supply Co.**, Washington, D. C.  
**Jos. Woodwell Co.**, Wood St. & Second Ave., Pittsburg, Pa.

**J. W. Lathrop & Co.**, Mystic, Conn.  
**G. D. Thorndike**, Portland, Me.  
**Jos. Brassard**, Central Falls, R. I.  
**Wallace Bros.**, Norfolk, Va.  
**The Autolight Motor & Supply Co.**, 508 N. Broad St., Philadelphia, Pa.  
**Pge Engineering Co.**, Baltimore, Md.  
**Smith Electric Engineering Co.**, Watertown, N.Y.  
**Kansas City Motor Car Co.**, Kansas City, Mo.  
**Neustadt Auto & Supply Co.**, St. Louis, Mo.  
**C. J. Smith & Co.**, 354 St. Peters St., St. Paul, Minn.  
**The Angier Co.**, Boston, Mass.

**The E. R. Cumbe Co.**, 1528 Court]Place, Denver, Col.  
**A. Baldwin & Co.**, 332 Baronne St., New Orleans, La.  
**Chanalor & Lyon Motor Supply Co.**, 930 S. Main St., Los Angeles, Cal.  
**Chanalor & Lyon Motor Supply Co.**, 503 Golden Gate Ave., San Francisco, Cal.  
**Wilson & Co.**, Ottawa, Ont., Can.  
**McCulloch & Boswell**, Winnipeg, Man.  
**Canada Cycle Motor Co.**, Toronto Junction, Can.  
**Schuman Carriage Co.**, Honolulu, T. H.  
**Geo. Neill & Co.**, 38 Fenchurch St., London, Eng.

# 212 Miles on a Pocket Battery

*Elmore* 1908  
Valveless 2-Cycle

More conclusive proof of the superiority of the Elmore two-cycle engine over any four-cycle type is impossible of even imagination than the recent test during which the Elmore Forty ran 212½ miles on six small pocket flash lamp batteries.

The very remarkable feature of this test is that when the machine was stopped (for the engine was still running and seemed good for many more miles when the test was abruptly ended to enable the showing of the batteries at the Chicago Show) these miniature cells registered only 2-10 of an ampere of current.

When it is remembered that the average four-cycle motor demands about four amperes of current to supply ignition it will be realized how truly marvelous is this performance.

It shows:

1. That the gas mixture in the Elmore two-cycle engine is scientifically correct.
2. That the ignition system which can run a car 212½ miles with so little current is as near perfection as the two-cycle principle itself.

Further and detailed explanation of this remarkable work will be furnished gladly if you will communicate with the nearest Elmore agent or write the factory direct.

**THE ELMORE MFG. CO., 1304 Amanda St., Clyde, O.**

MEMBERS A. L. A. M.

# THE LATEST

**Glass for Winter—TWO IN ONE—Screen for Summer**

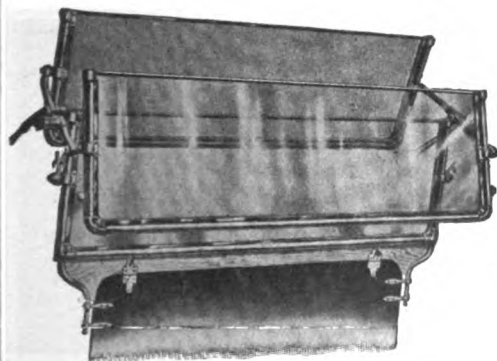

In a Class by itself.  
High grade construction.

THE  
**TROY**

Combination Folding  
Glass Front  
Wind Shield  
and  
Bug Screen  
*Patents applied for*

MANUFACTURED BY

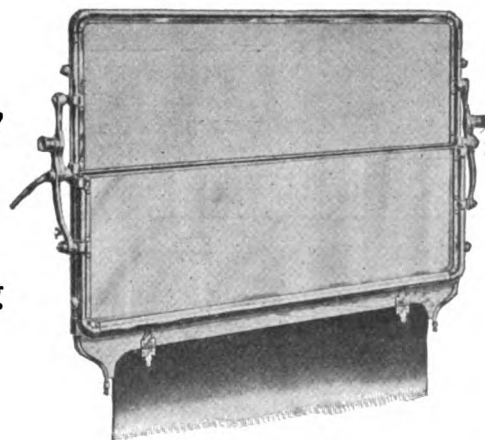

Perfect in operation.  
Positively no rattle.

**THE TROY CARRIAGE SUN SHADE CO., Troy, Ohio**



# THOMAS

## *The E. R. Thomas Motor Company Presents Four Styles of Chassis and Nineteen Styles of Bodies*

---

**THOMAS 4-20 TOWN CAR.** Combines luxury with utility and necessity; designed particularly for city and suburban use in good or bad weather, for calling and shopping, for the theatre, for social functions and touring on good roads. This car is furnished with brougham, landaulet, cabriolet, limousine and doctor's car bodies. In Europe this style of car is the vogue, as it rapidly is becoming in America. Prices, \$3,000 to \$3,250.

**THOMAS 4-40 DETROIT.** A marvel of smooth and quiet running with a dash in operation and distinctive style in appearance that denotes the thoroughbred and fascinates the most critical. The 4-40 has been strengthened and improved where the wisdom of experience has suggested. It is especially designed to successfully eclipse, at a much lower price, shaft-driven cars of the highest price and class. It is equipped with runabout, tourabout, touring and limousine bodies. Prices, \$2,750 to \$3,750.

**THOMAS 4-60 FLYER.** The Old Reliable is smoother, snappier, faster, lighter, quieter and roomier than ever. It has been redesigned and refined until it has become one of the most beautiful and stylish cars to be seen. The mechanical changes are largely refinements, though the motor generates more power. A bearing between each cylinder is still one of its chief characteristics. It is equipped with runabout, tourabout, touring, landaulet and limousine bodies. Prices, \$4,500 to \$5,700.

**THOMAS 6-70 SPECIAL.** This is the climax of automobile construction, and is one of the most powerful and flexible cars made, retaining, as it does, the structural principles that have counted so much for reliability in the Thomas 4-60 Flyer. There is not a single experimental feature in its entire construction. For speed, smooth running on hills and bad roads, and for slow speed, all on the high gear, the 6-70 Special is not equalled. It is equipped with runabout, touring, landaulet and limousine bodies. Prices, \$6,000 to \$6,900.

---

## E. R. THOMAS MOTOR COMPANY

Member A. L. A. M.

BUFFALO, N. Y.

# Garford

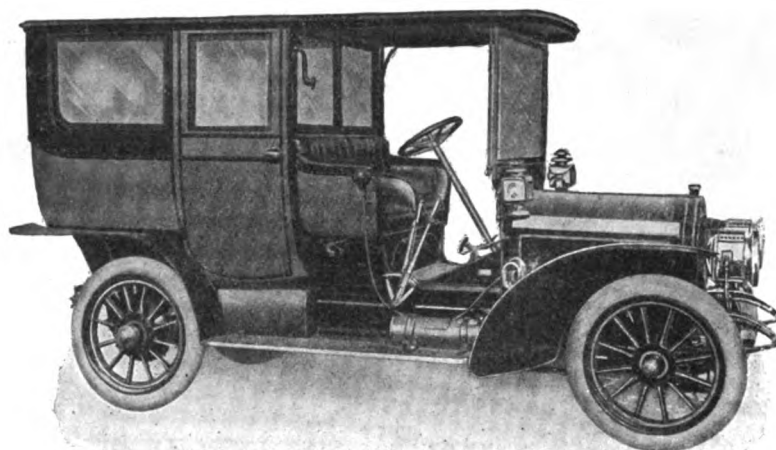

The Garford car bases its claim to attention on the fact that it aims to be orthodox in every essential. We have no "1908 Model." We had no "1907 Model." The present Garford, may be, if you please, our 1909 Model and our 1910 Model. There is not in the whole chassis a single feature that has not been proven correct. There is no freak device to become obsolete after its potentiality as a selling point has been exploded.

The Garford Car may advance with the automobile industry, and when safe, to anticipate that advance, but not to depart from it; but the Company protects its customer by its policy of conservatism, never departing from the type and never changing in essential features except as the "TYPE" itself changes.

#### ADDRESS

Eastern Inquiries  
Garford Motor Car Co., of New York  
1540 Broadway, New York City

Western Inquiries  
Garford Motor Car Co., of Cleveland  
1372 East 12th St., Cleveland



# It is the Practical Things that Count

In the recent three-day 600-mile Reliability Run of the Chicago Motor Club a

# Rambler

stock car with no special preparation or equipment made every control on time without an instant's delay or attention and finished in perfect condition.

A hypertechnical committee deprived us of a perfect score on account of a damaged tail lamp and loosened speedometer bracket, but the fact remains that this car underwent the most severe test ever devised without a seal being broken or the tool bag opened, and was at the finish in the same perfect condition as at the start.

Thus was the Rambler again proven

## THE CAR OF STEADY SERVICE

If you want a car that is **RIGHT** at a price that is **REASONABLE** with the backing of one of the most powerful companies in the industry, see the Rambler line for 1908.

Two touring cars and a roadster at \$1,400 and \$2,250.

Catalog 34 upon request.

---

## THOMAS B. JEFFERY & COMPANY

Main Office and Factory, Kenosha, Wis.

### BRANCHES AND DISTRIBUTING AGENCIES:

Chicago

Milwaukee

Boston

Philadelphia

San Francisco

# POPE-TOLEDO

---

---

## 1908

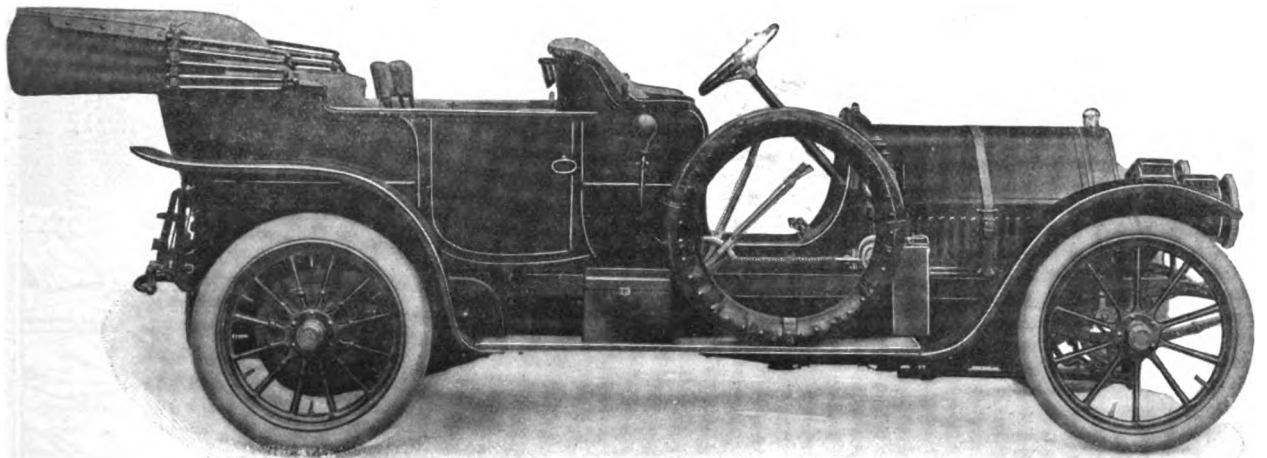

Characterized by extreme elegance of appointment, simplicity of design, and superb finish.

**Quiet, Comfortable  
and Very Speedy**

Shrewd, long-headed dealers have been strongly impressed with the wonderful showing made by the Pope-Toledo at New York and Chicago Shows.

---

Live dealers in unoccupied territory are invited to correspond with us.

---

**POPE MOTOR CAR COMPANY, Toledo, Ohio**

MEMBERS A. L. A. M.



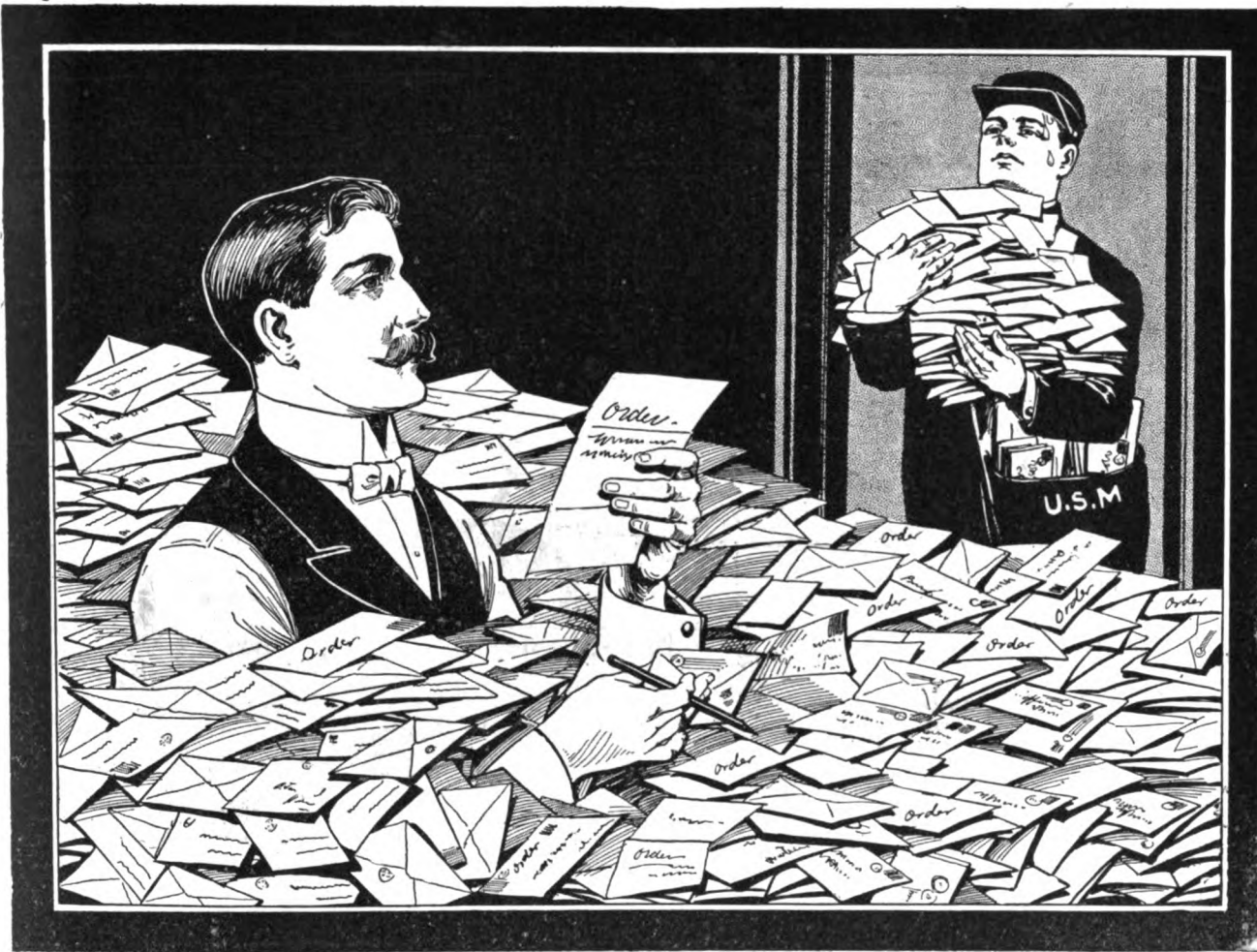

## Want Orders from Your Advertising?

¶ Then make your catalogs, booklets, trade-paper, newspaper and magazine advertisements **ATTRACTIVE WITH ILLUSTRATIONS.**

¶ The result of your advertising campaign is almost solely dependent upon your cuts. The use of illustrations will add 100 per cent. to their "pulling" power and "selling" quality.

¶ **Our fine Engravings bring results.**

¶ We make engravings which catch the eye, ornament the ad., and that have the "life," "snap" and "go" necessary to sell your product. As perfect engravings as can be produced for letter-press printing.

¶ Send us your orders—we guarantee satisfaction in quality, promptness and price.

## MOSS PHOTO-ENGRAVING CO.

295-309 Lafayette St., Cor. Houston  
("Puck" Building)  
NEW YORK CITY

# Are You Quite Satisfied?

Imported  
Die  
Forgings

Chrome Nickel Steel!  
Chrome Vanadium Steel!  
Special Auto Steel!

For all  
Automobile  
Parts

**COST LESS THAN CASTINGS IN THE FIRST PLACE!**

Round  
Bars  
All  
Sizes

Chrome Nickel Steel!  
Chrome Vanadium Steel!  
Special Auto Steel!  
Special Gear Steel!

Mill Lengths  
or cut off  
to suit  
Purchasers

**DO NOT HANDLE INFERIOR STEEL AT ALL!**

Designs  
and  
Drawings

Of Motors, Transmissions,  
Chassis or of other  
parts of cars

Made  
to  
Order

**AT A FIXED PRICE, FOR GUARANTEED WORK!**

Expert  
Attention  
Given

To the investigation of  
Automobiles,  
their Materials or Quality

Fearless  
Honest  
Opinion

**A STITCH IN TIME SAVES NINE!**

**J. M. ELLSWORTH**

**AUTOMOBILE ENGINEER**

**30 Pine Street  
New York**

**"Isn't  
It  
Great"**

**The  
Great  
Smith  
Four-  
Cylinder  
Touring  
Car**

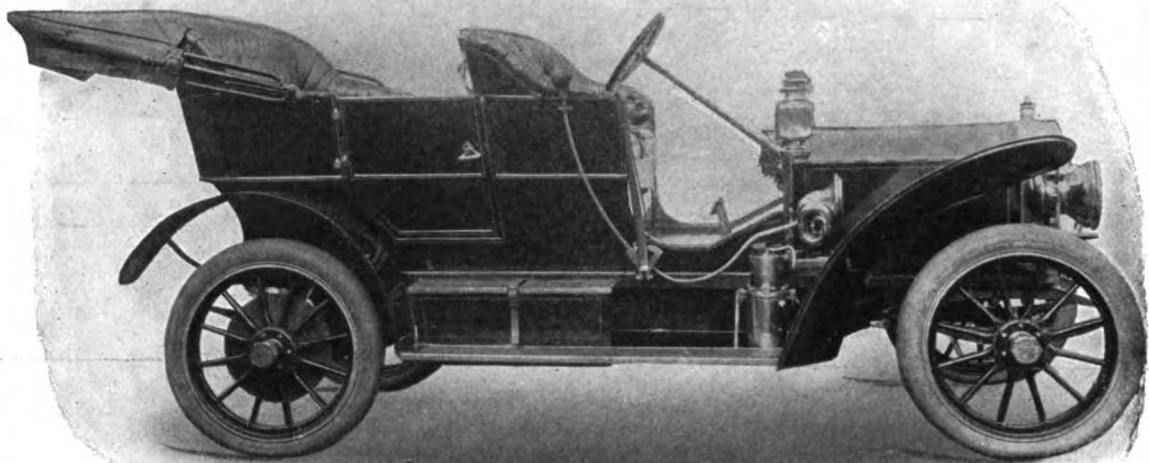

for 1908 is just as dependable as ever, it looks just as good and it behaves just as well.

These are the big things that count. Then come the little things, and this is where we have made improvements that have materially increased the general efficiency of our 1908 model.

The addition of roller bearings on the auxiliary shaft makes far less noise and more power. The tonneau door has been made two inches wider, and a quadrant has been placed over the steering wheel, giving better control of the throttle and spark levers.

Price, including lamp equipment - - - \$2,650.00

Price, including lamp equipment and Pantasote top - - 2,775.00

Our 1908 Literature is now ready.

**SMITH AUTOMOBILE CO., Manufacturers, Topeka, Kansas, U. S. A.** **SMITH MOTOR CAR CO.**  
Sole Distributors

# IMPERIAL ROADSTER

*The Car with the Straight Line Drive*

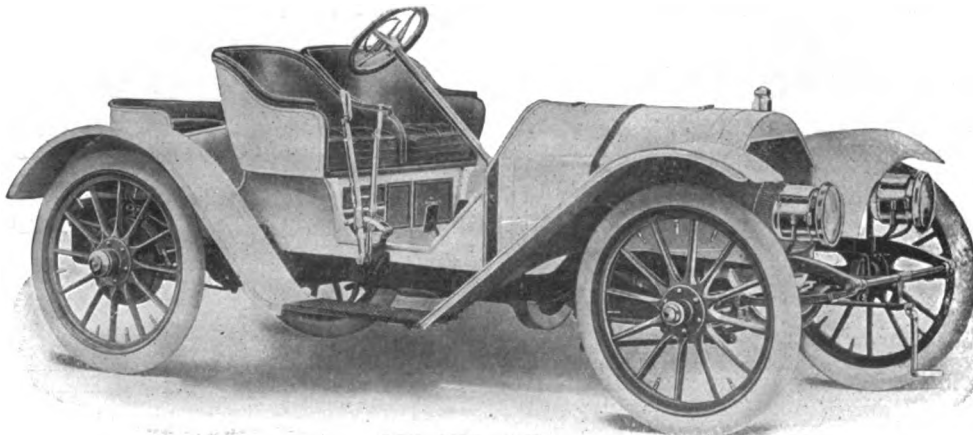

30-35 H.P., 36" wheels, selective type transmission, Eisemann Magneto, double system of ignition double drop frame. Price including gas lamps and generator, horn, tools, etc., \$2,500.00.

**IMPERIAL MOTOR CAR CO., Williamsport, Penn., U. S. A.**

Members A. M. C. M. A.

# THE INCOMPARABLE WHITE THE CAR FOR SERVICE

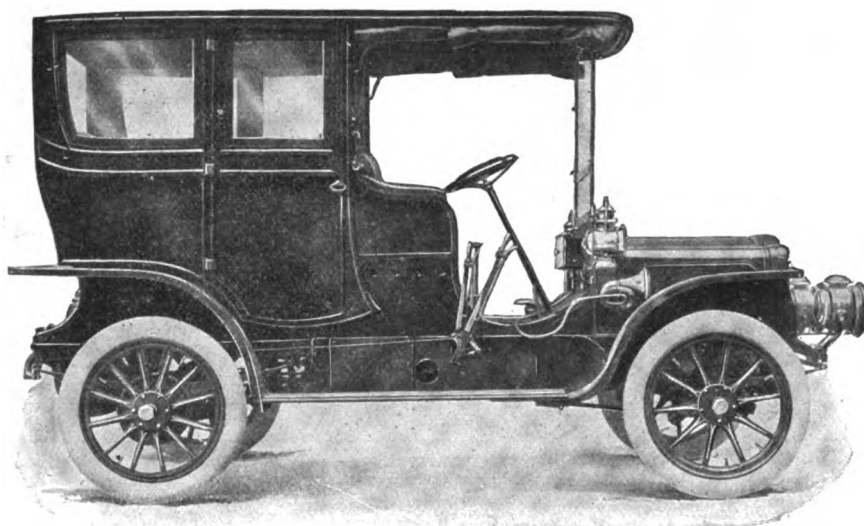

## Exclusive Features of the White Limousine.

The exclusive White quality of absolute noiselessness of operation is of particular advantage in a limousine because, in a car with a closed body, any noise made by the mechanism is even more noticeable and annoying than in an open vehicle.

Another exclusive White quality—namely—genuine flexibility of control, permits of the machine being guided safely and speedily through the crowded city streets. The speed of the White may be accommodated to the exigencies of street traffic without any changing of gears, jerky starts, or the embarrassing and sometimes dangerous “stalling” of the engine.

As regards graceful lines and luxuriousness of equipment and finish, the White limousine must be seen to be appreciated.

---

Write for catalogue and the address of the nearest branch Agency

---

**THE WHITE COMPANY**  
**CLEVELAND, OHIO**



# Packard

"THIRTY"  
1908

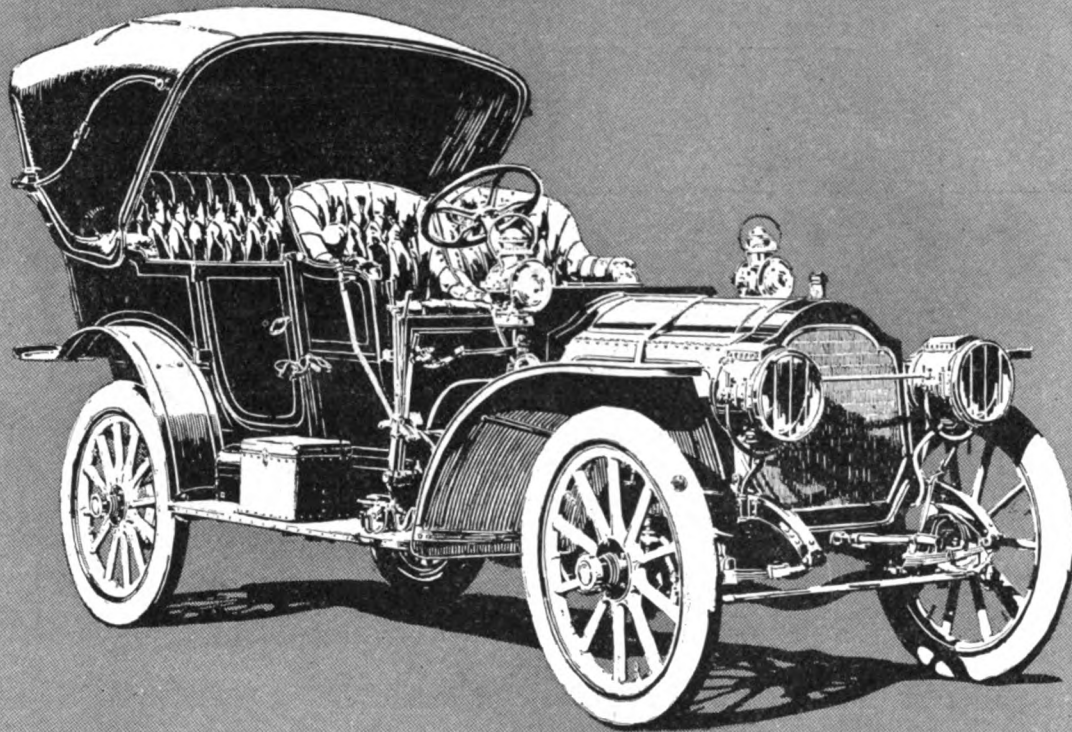

"Ask the man who owns one"

PACKARD MOTOR CAR COMPANY  
DETROIT, MICHIGAN

# THE MAN WHO DRIVES

## *The* "Maxwell"

knows what it is to experience all the pleasures of motoring without that eternal "gnawing at his bank-roll" as is the case with a high-priced, costly to operate car.

The little overdose of prosperity which resulted in the recent stringency has waked a lot of people to the fact that motor-car money's worth does not go hand-in-hand with fancy horse-power and exaggerated claims.

The "Maxwell" has never been a speed-car or a freak. It has never boasted hyper-horse-power.

It is, and has always been, a utility—a necessity—a family car without a "frill" in its construction.

The records it has established in hill-climbs, economy and endurance tests have never been equalled by any other cars, regardless of price.

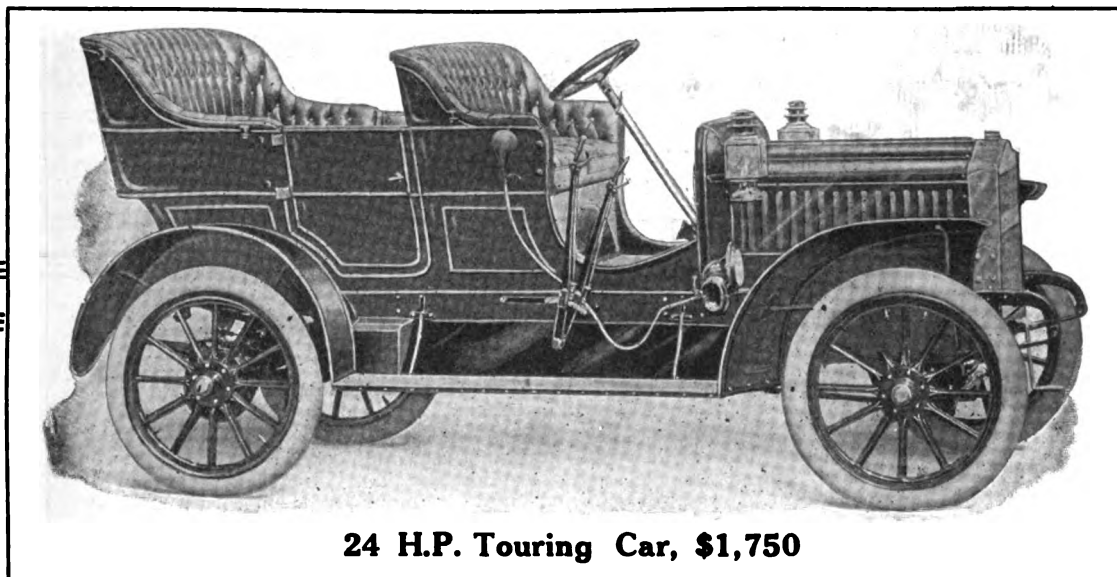

**24 H.P. Touring Car, \$1,750**

Mr. J. D. Maxwell's foresight in designing cars of unflinching efficiency, at prices well within the reach of the average citizen, has been well rewarded, to judge from the universal satisfaction of the 10,000 "Maxwell" owners.

That is why these days are "Maxwell" days. Every motor-car buyer will now get a dollar's worth of motor-car for every dollar he pays, and that is just what the "Maxwell" has always given.

Among the important features which the "Maxwell" was the first to introduce, are the three-point suspension, thermo-siphon cooling and multiple-disc clutch.

That features of such prime importance should have first appeared on cars of such low price—\$825 for the 14 H.P. Tourabout, \$1,450 for the 20 H.P. Touring Car and \$1,750 for the new four-cylinder 24 H.P. Touring Car—is one of the most remarkable incidents of the industry, and is evidence of how far in advance the "Maxwell" line is

*Get a "Maxwell Convincer" at your convenience in any car of the "Maxwell" line.*

*Address Dept. 3*

*Benj. Briscoe* President,

THE MAXWELL-BRISCOE MOTOR COMPANY

Members A. M. C. M. A.

Main Office: 30 Palisade Ave., TARRYTOWN, N.Y.

**FACTORIES:**

TARRYTOWN, N. Y.  
CHICAGO, ILL.

PAWTUCKET, R. I.  
NEWCASTLE, IND.

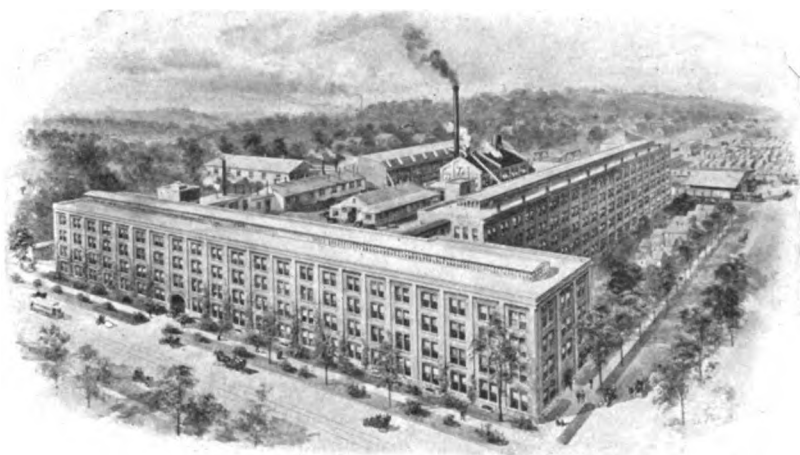

## THE FACTORY THAT MAKES FRANKLINS

The most perfectly planned and equipped automobile factory in the world.

### You ought to know the factory to know the Franklin

You ought to know the hundreds of tests and experiments—physical, chemical and electrical—going on all the time in the Franklin laboratory.

For example: the test of wood frames; the experiments by which we nearly doubled the elastic limit of a steel-drive shaft without increasing its size or weight; and similar experiments.

You ought to know how accurately every material is calculated, chosen and treated; how every detail of construction is adapted to its purpose regardless of cost; how scientific manufacturing gives full effect to scientific design.

You would then understand why Franklins, although the lightest-weight automobiles of their power, are the strongest and safest; and why they get more working-force out of an ounce of gasoline; and do more for their rating and price than any other motor-car.

But if you can't visit the factory, you can see its results at any Franklin dealer's. Write for the catalogue anyway.

H. H. FRANKLIN MFG. COMPANY, Syracuse, N. Y.

Members Association Licensed Automobile Manufacturers

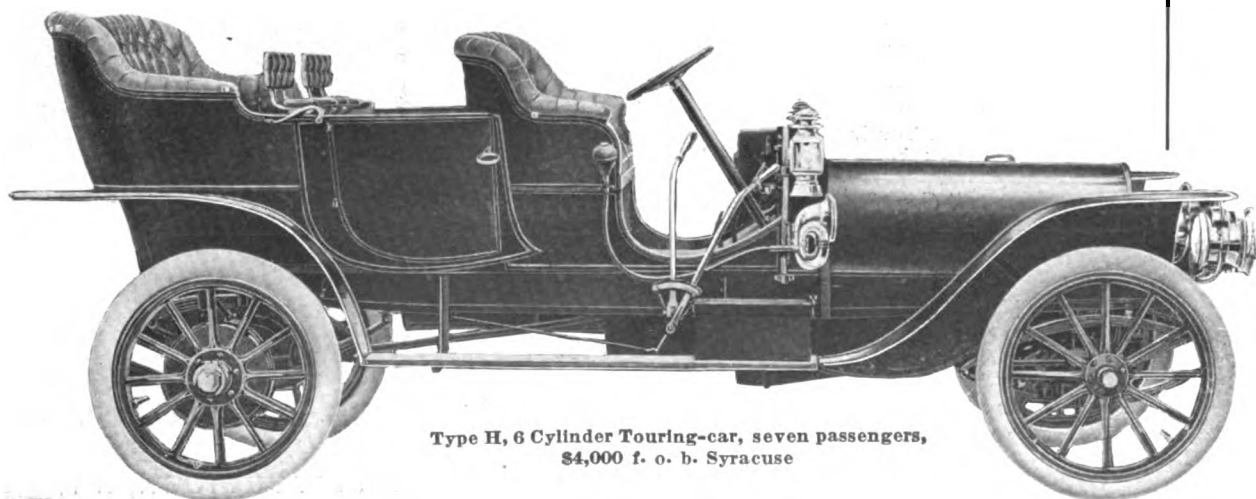

Type H, 6 Cylinder Touring-car, seven passengers,  
\$4,000 f. o. b. Syracuse

# Pettingell-Andrews Company

## ELECTRICAL MERCHANDISE

Boston, Mass.

### ANNOUNCEMENT TO THE TRADE

Pettingell-Andrews Co., Boston, Mass., exclusive selling agents for the  
**JACOBSON-BRANDOW COMPANY** PITTSFIELD, MASS.

Manufacturers of **High Grade Refined Ignition Apparatus**

Have you seen the J. B. SPARK COIL having  
**MICROMETER ADJUSTMENT, REMOVABLE CONDENSER  
 SELF INTERLOCKING UNIT SYSTEM**

We are now prepared to demonstrate to American Car Builders the marked efficiency of the  
**J. B. SPARK COIL**, and meet your requirements for 1908.

Address all  
 Correspondence to

**PETTINGELL-ANDREWS COMPANY, BOSTON, MASS.**

# RENAULT

## Simplicity

Even if you don't enjoy driving your car, you like to be able to operate it in case of emergency  
 You can learn to drive a RENAULT—and, incidentally, to enjoy driving—in a few minutes.  
 The RENAULT, with ordinary care, NEVER GOES WRONG.

### RENAULT PRICES:

50-60 H.P. 6 cylinder	
Chassis.....	\$8,250
35-45 H.P. 4 cylinder	
Runabout.....	7,250
35-45 H.P. 4 cylinder	
Touring.....	7,750
35-45 H.P. 4 cylinder	
Limousine or Land-	
aulet.....	8,250
20-30 H.P. 4 cylinder	
Runabout.....	5,750

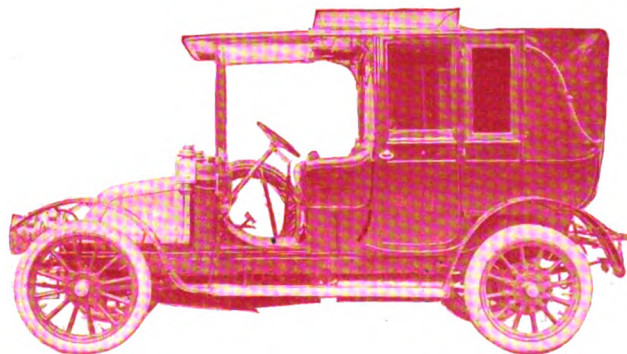

### RENAULT PRICES:

20-30 H.P. 4 cylinder	
Touring.....	\$6,250
20-30 H.P. 4 cylinder	
Limousine or Land-	
aulet.....	6,750
14-20 H.P. 4 cylinder	
Chassis.....	4,250
10-14 H.P. 4 cylinder	
Taximeter Cab....	3,950
8-10 H.P. 2 cylinder	
Taximeter Cab....	2,750

RENAULT led all cars in number of registrations in New York State during the last week in November.  
 No other foreign car ever won this distinction.

## RENAULT FRÈRES SELLING BRANCH,

PAUL LACROIX, General Manager

BROADWAY AND 57th ST., NEW YORK CITY

Telephone: 3004 Columbus

RENAULTS will be shown only at Importers' Salon, Madison Square Garden, December 28 to January 4





# Peerless

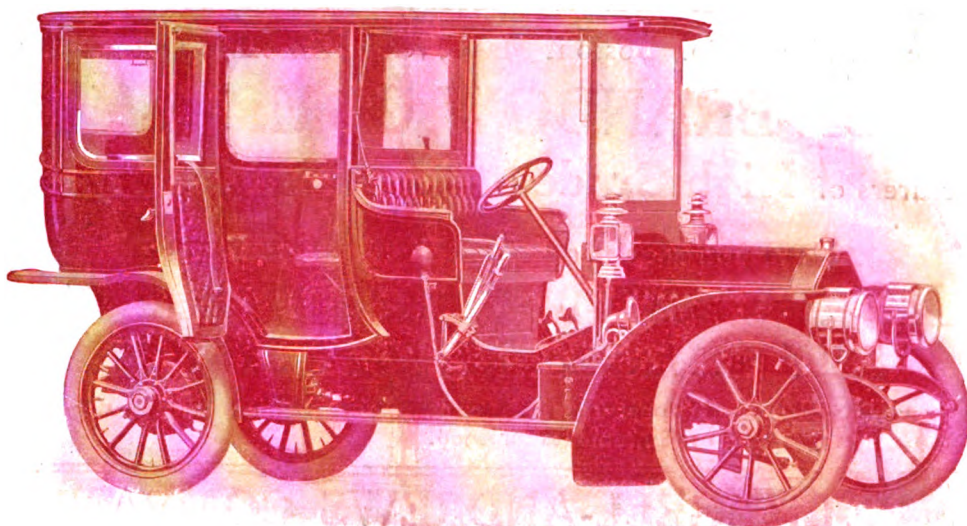

## AN EXCLUSIVE EQUIPAGE

**T**HE perfecting of the motor car is accomplished to a large extent by modification and elimination. The perfected Peerless limousine has been developed through such study covering many years. The aim has been not so much to build the largest number of cars as to build each car of the highest quality, workmanship and finish, calculated to give maximum satisfaction. The lines of the Peerless limousine are stylish and handsome, embodying every requisite for comfort. The utmost care is given to the finishing work on the bodies.

Examine carefully the merits of the Peerless cars before deciding definitely upon your car for the coming season. Write for special limousine book (D) giving a full description of the usefulness of the limousine.



**THE PEERLESS MOTOR CAR COMPANY**

2461 Oakdale Street

Cleveland, Ohio



# THE AUTOMOBILE

## Quaker City's Strenuous Endurance Winter Run Results in a Steam Winner

By G. M. Schell

PHILADELPHIA, Jan. 6.—At a meeting Sunday night of the contest committee of the Quaker City Motor Club, held at the Hotel Majestic, the White steamer was declared the winner of the MacDonald and Campbell Cup, emblematic of Class A honors in the club's New Year's run. The three-cornered tie of the White, Studebaker and Peerless was run off Saturday over the 172-mile course, and all came through without a single road penalization. After checking in the machines were taken to the garage of the Keystone Motor Car Company, where, with bodies removed, they were carefully gone over by the technical committee—Messrs. Swain and Sellers. It being impossible to gather the contest committee Saturday night to receive the technical report, Chairman E. C. Johnson issued a call for a meeting last night, when, although no figures were given out, the White was declared winner. It was then unofficially stated that the Peerless would be awarded second place.

It speaks well for the American automobile industry, of which the three clean-score cars are representative, and for the American manhood, of which the thirteen occupants of the cars in Saturday's run-over are likewise representative, that they should have withstood the rigors of road and weather as they did. True, the human end of the combination was so nearly "all in" when the finish was reached at City Hall, shortly after 4 o'clock Saturday afternoon, that some of them had to be helped from their seats; but in the face of such an abnormal elemental outburst human endurance was stretched almost to the breaking point. A piercing



HAL SHERIDAN AND HIS WINNING STEAMER.

northwester, penetrating even the heaviest furs and wraps, prevailed throughout, while a heavy snowstorm, followed by sleet and rain, persisted in falling. The cars lined up for the start at the Hotel Majestic according to their numbers—No. 9, Peerless, driven by Bert Maucher, W. C. Middleton, observer (Studebaker), E. C. Johnson, chairman contest committee, S. Stankowitch, Jr., and Charles Labelle, passengers; No. 10, Studebaker, driven by Frank Yerger, Frank Stockbridge, observer (White), W. Wayne Davis, committeeman, and A. J. King, owner, passengers; No. 17, White, driven by H. K. Sheridan, J. Macauley, observer (Peerless), E. H. Lewis, committeeman, and George H. Smith, White branch manager, passengers. The Peerless was sent away at 7:40, the Studebaker and White following at one-minute intervals.

Apart from the constant fight against the elements, there was little record on the trip, all the bad stretches—even the heart-breakers between Doylestown and Ottsville and between Allentown and Kutztown—being reached with something to spare. The Peerless had an awful close shave of it at Allentown, however. A new tire had to be fitted at Raubsville, and while pulling out to make up lost time a team was discovered, lines up, completely across the road, with the horses calmly drinking from a trough, while the driver was inside a hotel doing likewise from a glass. Maucher brought his car to a stop in time, however, but nearly spilled his passengers in the operation. The driver heard the yells and, coming out on the hotel porch, nonchalantly advised them to go to



FINISH IN FRONT OF QUAKER CITY MOTOR CLUB'S QUARTERS.



O. W. HOFFMAN'S STEARNS.



ROBERT SHIRK'S STODDARD-DAYTON.



TOM BERGER'S OLDSMOBILE.

some warm resort and let the horses finish their drink. It cost another delay of two valuable minutes before they could proceed, and it was only by the taking of the riskiest kind of chances by Maucher that the Peerless reached the Easton control just nine seconds short of a down-and-out penalty.

**Fast and Furious Weather Made the Ride Galling.**

So bad had the weather become when Allentown was reached that a dozen ladies' veils were bought to protect the faces of the travelers from the stinging sleet. In ten minutes the veils had become saturated with a plaster of snow and sleet and were thrown away, the tonneau passengers crouching behind the front-seaters and constantly wiping the drivers' goggles to give them a chance to see the road.

After reaching Kutztown, where the bad going ended, the heavy strain on the cars ceased, although the slippery roads necessitated careful driving. The endurance test of the passengers, however, became more strenuous, for with the increased speed of the cars came added force to the pellets of sleet. The rests in control, however, enabled all hands to hold out until City Hall was reached, but all were grateful that the finish came when it did, as the driving sleet cut like needles and was numbing to the senses.

Like all affairs of the kind held in this section during the last three years, there promises to be an aftermath. Beginning with the protest of the White contingent, first against the reinstating of the Studebaker to the clean-score class on the ground that

a broken shock absorber is not an accessory, and later against the removal of the Peerless penalty for a free-play transmission on the ground that all Peerless transmissions are so assembled, there have been some rather hasty insinuations flung about, which go to prove the necessity for the adoption of a different method of appointing technical committees in future similar contests. As the A. A. A. is the court of final resort in the settlement of all disputes, say some of the cool-headed ones, why should not that body take this matter in hand at once and prevent all kinds of trouble by appointing a committee of, say, three experts to report on the condition of all cars after such contests, their expenses to be paid by the promoting organization. The suggestion, it is believed, would meet with hearty approval by all interested in the sport.

**Detailed Story of the Main Event.**

The second annual New Year's endurance run of the Quaker City Motor Club came to its scheduled conclusion at 3:15 o'clock Thursday afternoon, when the finish judges, at the City Hall, pulled down their flags. But it was long after 1 o'clock next morning when the contest and technical committees finished their labors at the Hotel Majestic and announced the triangular tie for Class A honors, involving the White, guided by "Hal" Sheridan; the Studebaker, driven by Frank Yerger; and the Peerless, with "Bert" Maucher up. Three other cars came to the finish minus road penalizations—Tom Berger's Oldsmobile, O. W. Hoffman's Stearns, and Robert Shirk's Stoddard-Dayton,



A PACKARD NON-CONTESTANT



OF COURSE THERE WAS A FORD.



AND ALSO A FRANKLIN.



but when President Swain and the other technical committeemen gave them a critical overlooking the unlucky trio fell down and were variously penalized. C. J. Trumbull's Packard won the Class B cup for roadsters, the Maxwell the Class C trophy, and Dan Webster was voted the "most popular driver" cup in Class D, with a Frayer-Miller.

In Class A the Studebaker and Peerless no-penalty cars should, in the opinion of some experts, have also suffered penalization, the former by reason of its broken shock absorber and the Peerless on account of too much play in the transmission. But the officials ruled that a shock absorber was not a part of the Studebaker's regular equipment, and accepted evidence to show that it was the Peerless policy to send out its cars from the factory with transmissions permitting of some play. In the latter case a 10-point penalty had been inflicted on the Peerless, and so announced, but the long and hard kick that followed had its effect, the penalty was lifted and the Peerless



HAL SHERIDAN AND HIS WHITE TRAVELER EN ROUTE PASSING ONE OF THE OFFICIAL CARS.

run with a rear wheel out of true, and declares he called attention to it before the start. Nevertheless, when the eagle-eyed technical committeemen saw the slight wobble they promptly plastered 5 demerits on the Oldsmobile. The Stearns penalty resulted from a cracked front spring and caused 9 points penalty. A car not sufficiently tuned up crushed the Stoddard-Dayton contingent's

hopes of first place. Just from the factory, several nuts worked half a turn loose, and before the committeemen had finished their work with the spanner the car had accumulated 45 bad marks.

Hard luck stories came also from the Matheson camp, whose two cars made really excellent showings—Anderson's having but one point road penalty and Dietrich's but three—and both afterwards went through the technical committee gauntlet without the semblance of a demerit being chalked up against them.

A momentary stoppage of the engine due to dirty gasoline accounted for the Lozier's two road demerits.

Frank Lefem's Garford, No. 26,

was one of the few who survived the first day's run with a clean score sheet. The car would probably have repeated on the second day but for a collision with a cart, which was not only responsible for 15 bad marks on the road, but for 50 points penalty for a bent axle, crooked mudguards and a few other trifling defects resulting therefrom.

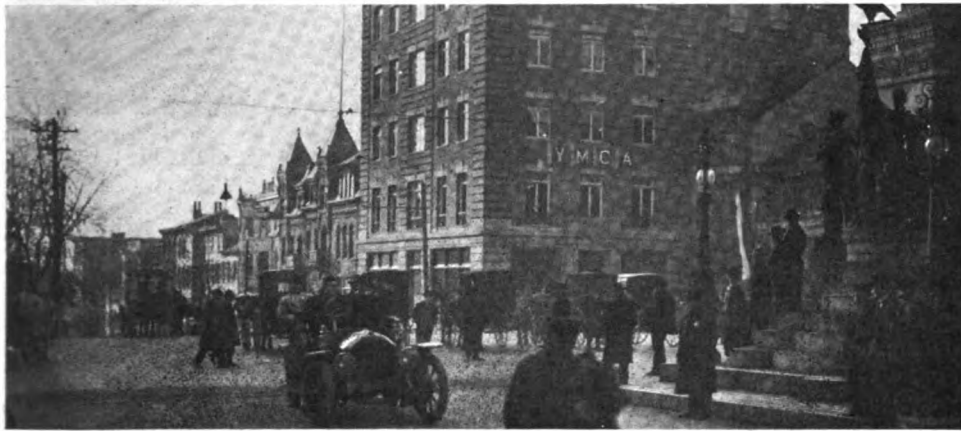

PEERLESS TIE PERFORMER ROUNDING MONUMENT AT ALLENTOWN ON SECOND DAY.

was let into the ranks of the elect. The contest committee further decided that the three clean-score cars should cover the route Saturday under the same conditions, in order to determine the winner of the MacDonald and Campbell cup.

When the announcement concerning the Studebaker and the Peerless reached the White contingent they immediately filed a protest and put in a claim for the cup on the ground that theirs was the only car in the run that had covered the course without road penalizations and had been found flawless at the finish. They argued that shock absorbers were auxiliary springs, and had been so declared when a similar question arose in the Glidden tour and the recent Chicago endurance run.

There were other whispers of dissatisfaction with the rulings of the technical committee, especially from the Motor Shop people, both of whose cars, the Stearns and the Oldsmobile, finished with clean scores on the road, only to be penalized. Berger started on the



STUDEBAKER TIE CANDIDATE FOLLOWING THE CONFETTI CAR ON THE SECOND DAY.



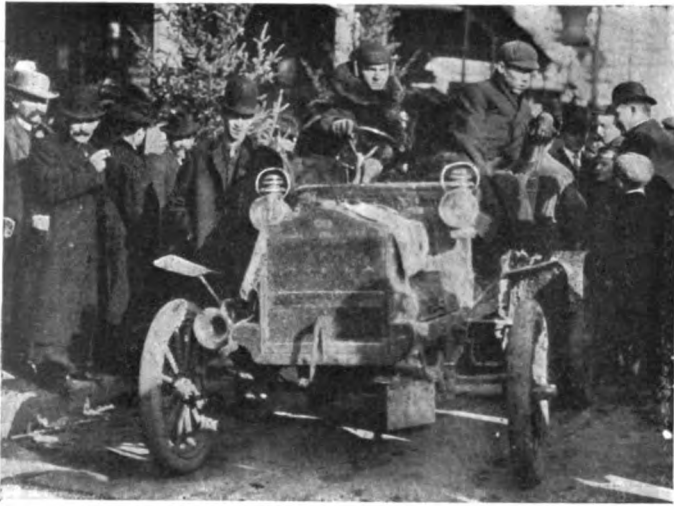

THE MAXWELL, WHICH PROVED A STURDY COMPETITOR.

J. W. Florida's Locomobile, despite its 109 road demerits, due to tire troubles, technically came through unscathed.

The battle for Class B honors resolved itself into a duel between Trumbull's Packard and the big Thomas, driven by E. T. Youse. The latter, unfortunately, suffered two punctures just before reaching the night control on the first day.

Another creditable performance in Class B—really one of the best, in fact—was that of A. A. Jones' Ford runabout, which went out of its class and came through with a total of but 20 points penalty, all on the road.

Despite a penalization of 51 points, the little Maxwell runabout won the Class C cup over four contestants.

Only One Accident on the Run.

The bad Doylestown-Ottsville stretch was responsible for the only accident to a contestant. Hugh Coyle, a mechanic in the Columbia car, was catapulted from his seat when the machine struck an unexpected "thank-you-marm." He hit the ground with his face and despite several bad cuts continued on to Allentown, where he received medical attention.

Some idea of the road conditions on that fatal second lap on the first day's run may be had from the fact that but a dozen of the 39 starters in Classes A and B came through it unscathed. The twenty-miles-an-hour maximum—for anything in excess of which the State will not stand, and upon which the contest committee based its schedule—was almost too much for even the big fellows. Deep frozen ruts and sharp-edged stones embedded in the hard mud as firmly as in cement were the determining factors, and there was little danger that the speed limit would be exceeded under such conditions.

Tire damages were so numerous along the Ottville-Doylestown stretch that it seemed almost as if every other car was either stalled for repairs or limping along, hoping to reach the Red Hill Hotel at Ottsville and make repairs after passing through the control.

Some portions of the first leg of the second day's journey was a replica of the Doylestown-Ottsville road, with the ruts, if anything, a trifle deeper. But there were smooth spots where time could be made up and stalled cars passed, and the 57 minutes allowed to cover the 18.2 miles meant very close sailing. Beyond Kutztown, all the way to Reading, the going was excellent. And from the Berks capital over the hard old Philadelphia pike it was child's play for all the cars.

The official schedule followed by the contestants is appended:

FIRST DAY.				
Control.	Miles.	Total Dis.	Time	Total Time.
To Doylestown .....	26.7	26.7	1:16:00	1:16:00
Ottsville .....	11.8	38.5	0:33:00	1:54:00
Easton .....	18.5	57.0	0:54:00	2:48:00
Allentown .....	21.9	78.9	1:06:00	3:54:00

SECOND DAY.				
Control.	Miles.	Total Dis.	Time	Total Time.
To Kutztown .....	18.2	18.2	0:57:00	0:57:00
Reading .....	16.5	34.7	0:48:00	1:45:00
Pottstown .....	16.6	51.3	0:51:00	2:36:00
Norristown .....	19.4	70.7	0:57:00	3:33:00
Philadelphia .....	23.0	93.7	1:21:00	4:54:00

The Tables That Tell the Story.

In the following table are shown the penalties inflicted on the various cars on both days. So disgusted were some of the drivers that they failed to turn in their cards on time the first day. In their cases penalties are shown in second day's column:

CLASS A.—TOURING CARS; MACDONALD-CAMPBELL CUP. Penalties.

No.	Car.	Driver.	1st D.	2d D.	Tech.	Total.
17.	White	H. K. Sheridan	0	0	0	0
10.	Studebaker	Frank Yerger	0	0	0	0
9.	Peerless	Bert Maucher	0	0	0	0
14.	Matheson	Ross Anderson	1	0	0	1
7.	Lozier	H. Michener	2	0	*	2
19.	Matheson	J. M. Dietrich	3	0	0	3
2.	Oldsmobile	T. W. Berger	0	0	5	5
21.	Pullman	H. P. Schade	7	0	*	7
1.	Stearns	O. W. Hoffman	0	0	9	9
16.	Franklin	W. Crawford	11	0	*	11
3.	Locomobile	W. J. Fox	**	12	10	22
18.	Kiesel Kar	Webb Jay	24	0	*	24
13.	Acme	M. Llenen	**	26	*	26
6.	Stevens-Duryea	J. A. Moran	23	3	*	26
15.	Peerless	F. B. Huyette	10	21	*	31
27.	Royal-Tourist	H. B. Hills, Jr.	8	30	*	38
22.	Frayser-Miller	H. Knepper	**	16	25	41
24.	Corbin	W. Cathcart	39	3	*	42
12.	Stoddard-Dayton	Robert Shirk	0	0	45	45
11.	Studebaker	A. J. Kling	4	60	*	64
26.	Garford	Frank Laffan	0	15	50	65
20.	Autocar	P. Aschenfelder	18	89	*	107
4.	Locomobile	J. W. Florida	**	109	0	109
25.	American	C. A. Percival	68	53	*	121
28.	Crawford	J. Crawford	168	0	*	168
8.	Columbia	H. P. Fry	4	170	*	174
5.	Mitchell	H. W. Greenawalt	**	186	*	186
23.	American Mors	A. J. Martin	15	207	*	222

\* Did not turn in cards.  
\* Not examined by technical committee.

CLASS B.—ROADSTER; FOR QUAKER CITY MOTOR CLUB CUP.

No.	Car.	Driver.	1st D.	2d D.	Tech.	Total.	
52.	Packard	C. J. Trumbull	0	0	0	0	
54.	Thomas	E. T. Youse	5	10	*	15	
56.	Ford	A. A. Jones	11	9	*	20	
58.	Pullman	S. Laffan	7	27	*	34	
59.	Pullman	R. Morton	3	34	0	37	
61.	Stearns	S. H. Collom	0	0	40	40	
53.	Autocar	R. W. Waynes	**	100	*	100	
51.	Oldsmobile	P. E. Varney	75	37	*	112	
57.	Ford	W. Henry	**	397	*	397	
55.	Packard	Thos. Wilkinson	Dropped out.				
60.	Parkin	J. W. Parkin, Jr.	" "				
62.	Columbia	F. Gilkinson	" "				

\* Did not turn in cards.  
\* Not examined by technical committee.

[In Class C the contestants were not required to check in at the intermediate controls. Only at the start and finish each day were they required to report, and no penalties except for lateness or previousness at each day's finish were inflicted.]

CLASS C.—SMALL RUNABOUTS.

No.	Car.	Driver.	Penalties.
79.	Maxwell	T. Hathaway	51
76.	Mitchell	W. M. Crane	62
77.	Pullman	Wm. Rockey	189
75.	Autocar	J. A. Hess	D. O.
78.	Pullman	J. Johnson	D. O.



THIS PRESS CAR OCCASIONALLY STOPPED ON THE ROAD.

## A. C. A. INAUGURATES DYNAMOMETER TESTS

EVER since the automobile got beyond the rudimentary stage there has been a demand for a testing instrument that would not alone reveal its power output accurately, but also its speed, grade-climbing ability, frictional loss in the various steps of the transmission of the power and other essentials of similar importance. To a certain extent, practically every man-



W. K. VANDERBILT, JR.'S 90-HORSEPOWER RACER BEING TESTED.

ufacturer of automobiles in the country has invested in apparatus to ascertain as accurately as possible one or more of these factors, but in general the knowledge sought by such testing has been confined to the power output of the motor alone. In some instances, investigations have been carried further than this, as in the case of the testing plant installed by Purdue University, but it has remained for the Automobile Club of America to make by far the most important advance in this direction. The members of this organization recognized the value of such data at an early day, and in 1904 Dr. Schuyler S. Wheeler, first vice-president of the club, and one of the best known electrical engineers in the country, was formally commissioned by the club to evolve a machine which would make it possible to accurately determine the before-mentioned factors in the ability of a car.

On Monday afternoon last there was exhibited on the top floor of the spacious new clubhouse in Fifty-fourth street the concrete result of the three years' study and labor that Dr. Wheeler has devoted to the matter. It is termed a dynamometer, but the ordinary acceptance of that term falls far short of conveying an adequate idea of the completeness of the apparatus which it includes. A dynamometer is merely a power-measuring instrument, the use of which supplies certain data from which the power output of the machine tested can be calculated. In this case it is the most complete assemblage of power-absorbing and measuring instruments that has ever been built for a similar purpose, and the outlay involved in its construction and installation—something like \$10,000—would naturally place such an equipment beyond the reach of the individual manufacturer. The matters of power measurement, integration and automatic recording of the final results have been carried much further than has ever before been attempted. It is no longer necessary to calculate the results from the data thus obtained, for the speed, tractive effort and horsepower may be read at a glance on the large chart.

The equipment consists, in the first place, of a pair of large drums carried on a shaft supported on ball bearings and placed beneath the floor in such a position that the upper part of the periphery of the drums just projects through the floor above, in

such a manner that the rear or front wheels of a car may be run upon them and held there. At the left-hand of this shaft, as shown in the illustration entitled "View Beneath the Floor," will be seen a huge pendulum. When the car is run upon the drums it is held in that position by block and tackle, as will be apparent from the first illustration showing W. K. Vanderbilt, Jr.'s, 90-horsepower Mercedes racing car on the testing stand. As the entire power of the car that is delivered at the rear wheels is transmitted directly to the drums, the pull on the latter causes the pendulum to swing from the vertical, a distance exactly proportional to the effort exerted by the car. A continuation of the pendulum is carried through to the floor above, where it forms an indicating pointer for the instrument, showing the tractive effort in pounds, this being very clearly shown in the third illustration depicting the relative positions of the pendulum and car while the latter is undergoing a test. At the extreme left-hand of the shaft supporting the drum and just beyond the pendulum in the view of the apparatus beneath the floor will be seen two small cylinders and pistons. These play the part of a dash-pot to prevent the pendulum from oscillating as the power delivered by the car varies, one keeping it steady while the pendulum swings in one direction, as represented by the forward speed of the car, and the other when running backward, this also explaining the duplication of the scale of the instrument showing the tractive effort.

Just to the right of the pendulum is the hydraulic brake which absorbs the power delivered by the car, while at the opposite end of the shaft is a large electric motor which is used to turn the drums in order that the car may be run from them, to determine the amount of friction and the consequent power loss in the various steps of the transmission, for verifying speedometer readings by comparing them with the record of the instrument and similar purposes, the front wheels of the car being placed on the drums in the latter instance. It also permits of testing the brakes and measuring the amount of power they absorb when fully applied with the car running at different speeds. This completes a description of the most important essentials of the equipment located beneath the testing floor and on which only the recording and controlling instruments are placed. In the order in which they appear at the left-hand of the testing room, as shown in the large illustration, these are the traction indica-

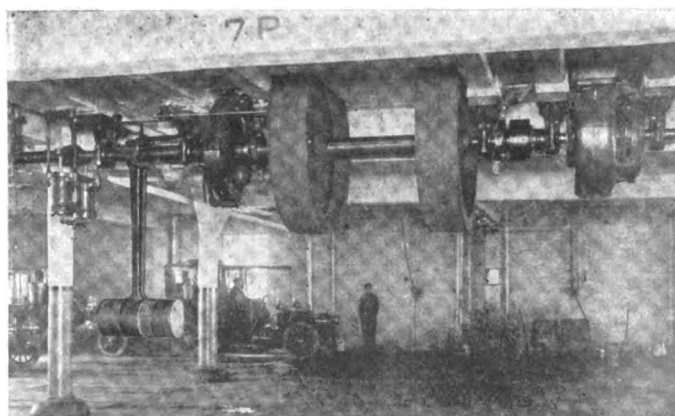

VIEW OF THE ESSENTIALS LOCATED BENEATH THE TESTING FLOOR.

tor, the speed indicator, the switchboard, the motor generator, the grade indicator and the large chart at the rear, which sets forth the concrete results in such form that they may be read at a glance. The working of the traction indicator has already been explained, its reading being the direct result of the movement of the pendulum beneath the floor.

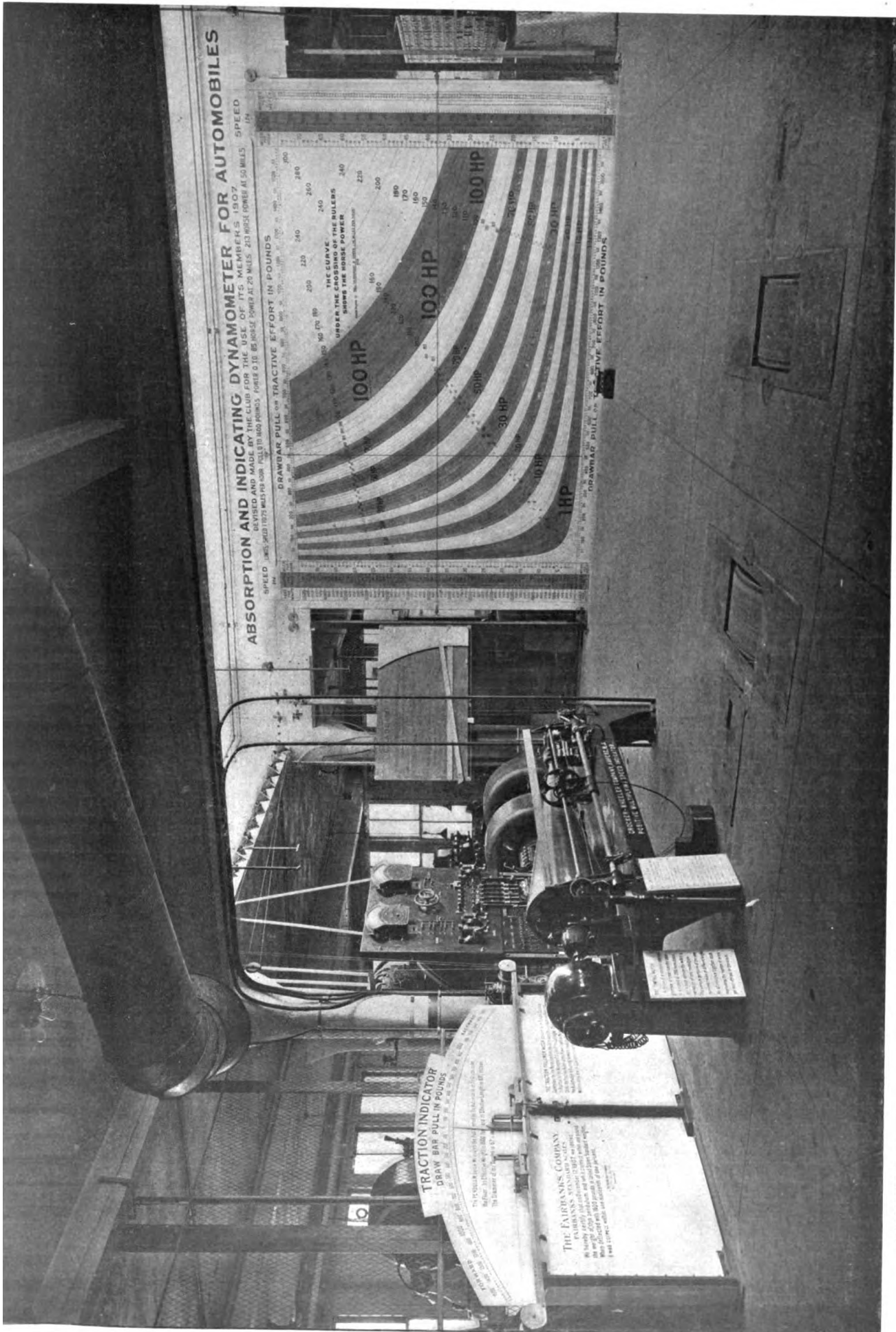

MECHANICAL PLANT AND CHART OF THE AUTOMOBILE CLUB OF AMERICA'S DYNAMOMETER—THE MOST COMPLETE SET OF AUTOMOBILE-TESTING APPARATUS EXTANT.

The speed indicator shown before it is an extremely delicate and accurate electrical instrument devised by Dr. Wheeler which would require a chapter of some length to do justice to it. In brief, it consists of a conical drum of considerable length, which is revolved continuously at a speed of 200 r.p.m., this speed being verified by a bell which rings automatically every thirty seconds, or 100 revolutions of the shaft, so that the method of measurement is based upon an instrument running at a constant speed like a clock, and which can be easily verified at any time, thus maintaining its accuracy. Against this conical drum there is pressed a light bronze wheel or roller, splined on a shaft which is directly driven by the automobile and adapted to be slid back and forth on this shaft by a small independent electric motor, according to the varying speed of the car until it comes to a rest at a point where the speeds of the cone and wheel agree, this representing the speed at which the car is then traveling.

In conducting the first public tests, which were held on Monday afternoon last before an interested gathering, the club's 30-horsepower car was placed on the drums. It showed a maximum speed of 15 miles an hour on the first speed, the drawbar pull being 510 pounds and the effort developed at the rims of the rear wheels 20 horsepower. This gives a ratio of pull to weight of 20 per cent., which is also the equivalent grade per cent. On second speed the car reached 25 miles an hour, with a drawbar pull of 340 pounds, and showed 22 horsepower at the wheels, while on the third, or direct drive, it ran at 36 miles an hour, with a pull of 270 pounds, and registered 25 horsepower at the drivers, thus giving a combined efficiency for the motor and transmission of 83.4 per cent., based on the car's rating of 30 horsepower, which is a most excellent showing indeed. On the coasting test the power absorbed reached 280 amperes at 100 volts, or the equivalent of slightly in excess of 38 horsepower, while on the speedometer test, the instrument used being a Hofecker, both agreed at ten miles an hour, but the latter fell behind the reading of the instruments at the higher speeds, one mile at 20 miles an hour, 1 1-2 miles at 30 miles and 2 miles at 40 miles an hour.

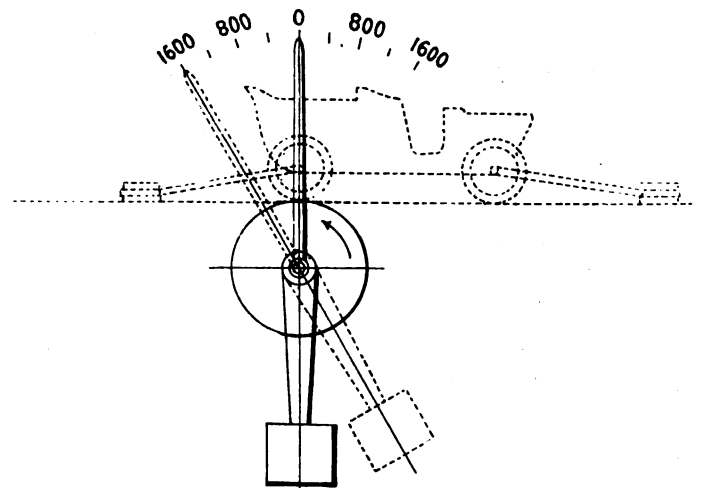

HOW THE CAR'S PULL IS MADE TO ACT ON THE PENDULUM.

W. K. Vanderbilt's 90-horsepower Mercedes racing car was then placed under test, but it was found that its drawbar pull was so high on the first speed that the hydraulic brake did not get sufficient water pressure to absorb all the power the motor developed. At present the only pressure is from a roof tank, but a special pump is being installed to overcome this difficulty. However, it reached a pull of 880 pounds at this speed, at 21 miles an hour, showing 50 horsepower at the wheels. It was then tried on the direct drive and reached a speed of 74 miles an hour, at which the din in the room was terrific. An anomalous result of this test was that at this high speed the reading of power delivered at the driving wheels was only 30.

Among those present at the tests were Colgate Hoyt, president of the A. C. A.; David H. Morris, and Albert R. Shattuck, former presidents of the club, and Robert Lee Morrell, Dr. Schuyler S. Wheeler, Commodore Frederick G. Bourne, and Secretary Samuel S. Butler.

## ALPINE EXPERIMENTS BY NEW YORK-PARIS TOURISTS

PARIS, Jan. 1.—De Dion, Werner, and Benz splashed down the muddy suburban road, bound southward, with a wash of water from the front wheels which would have honored a torpedo boat destroyer. Collignon, who had charge of the procession, muttered that it was nothing, though a stream of liquid would persist in trickling down the spine, despite rubber shirts and storm helmets. But a man who had done Pekin-Paris had a reputation to uphold and could not be expected to grumble at a deluge. Benz and Werner looked as if they enjoyed it.

Two days later, after a non-stop run of 220 miles in non-stop rain, the New York-Paris trio had reached Avallon, and the next morning were at Briançon, in sixteen inches of snow, with a stinging cold, 14 degrees below zero. It is a soft, cottony snow that swallowed up the cars to their axles, not the kind we shall meet in Siberia, declares Lelouvier, for there it is hard, firm almost as macadam.

At night, when we were ready to smuggle under the immense eiderdown on the high-clearance wooden bedstead in a chilly upper room of the hotel, the round-the-world trio were bundled out into the open air to judge the effect of the non-freezing solution which Eugène Boujé had supplied.

Everybody was too excited to bother about breakfast, and at 5 o'clock Collignon and his mates were around the cars wrenching off the radiator caps to see if the water was frozen. It was all right—as clear and liquid as if just drawn from a mountain spring—and a jump was made for the cranking handle. But this was a more difficult matter. For quarter of an hour the De Dion was wound up, with no other response than a hollow

suc-suc-suc. Another quarter with the same result, then another, only to warm the men but leave the motor as cold as a statue. Then everybody wanted to know why the air inlet had not been fitted with a warmer for a car that had to knock about six thousand feet above the level of the sea. A little external heat judiciously applied produced a responsive roar of a hearty, healthy tone.

Then, for the first time in the history of the world, three automobiles climbed around the face of Mount Geneva in winter, traveling over tracks which had up to then been sacred to the sleigh. On the frozen grades, where the car seemed to stand on end, the anti-skid wheels flew around merrily, tearing the rubber surface to shreds. Smooth tires would certainly have been better, but, best of all, would be steel-spiked rims. After every imaginable stunt on frozen snow and impossible grades, a snow bath was ordered for the Benz, and in a second the big car had plunged into a glittering, downy mass that enveloped to the top of the frame. But the 40 horsepower under the bonnet continued to hum their monotonous tune and half an hour later it was proved that a wicker platform under the car would prevent it sinking in any depth of soft snow, and that half a dozen willing hands working in unison with a healthy motor would soon allow one to back out to terra firma.

Next week Werner will be down again to experiment with a kind of sleigh runner on the front wheels and to make further trials of the equipment as suggested by these experiments in the snow. One thing, however, is certain, we have nothing to fear from deep snow or the severest cold.



# MAN, HORSE, AUTOMOBILE, AND THE HIGHWAYS

FROM the Lima Automobile Club, of Lima, O., there has come a little book on the outer cover of which is the title: "The Man, the Horse, the Automobile, and the Highways"; inside the designation is "The Highways and Road Etiquette." The club states: "This little book is sympathetically dedicated to the 'old hoss' which finds the 'old pike' a hard road to travel." There is so much common sense and timely advice to automobilists that, in view of the title-page announcement of "Copyrighted by Everybody—No Rights Reserved," the text matter is herewith reproduced with thanks to the enterprising Ohio club:

The Lima Automobile Club herewith sends greetings of good fellowship to every owner of a horse in Allen County, and during these long winter evenings we wish to sit down with you at your own comfortable firesides and chat over some of the things which are of mutual interest to the Horse, the Automobile and the Walker. There is no politics about this, but it is full of good, practical religion, for it has to do with the prosperity, comfort, safety and happiness of everybody in the county, and to facilitate this friendly intercourse let us lay aside all prejudice and be frank and honest to each other, and see if we cannot establish good, neighborly relations between the users of the horse and the automobile, based on the golden principle that each has the same "free and equal rights" on the public highways which we all have had a hand in developing from the forest trail to the perfect pike.

The "perfect pike" is yet to come, but its coming is assured and cannot much longer be delayed. As long as we were compelled to go on foot or on horse-back, we did not complain of the trail. It was all we needed then. The "earliest settler" (our fathers and grandfathers) was too busy with his ax and grub-hoe in preparing a spot of ground on which to raise a few potatoes and a little corn for his wife and babes, to spend his time on the road; therefore it made little difference to him whether it was good or bad—or no road at all. But lo! the change! By and by he had a little surplus corn or wheat. He must sell it—must haul it away to some market where he could get a little cash. This necessitated WAGONS. Wagons necessitated ROADS! So by littles they were commenced. Trees were cut; soft spots were covered with poles and split logs. This gave the "corduroy," that served the purpose for the time being. But crops increased, better roads were found to be necessary in order to get the products of the farm to market. All night out on the road—stuck in the mud—half of the time—would not do the thrifty farmers. They must have roads that were more passable. So they bridged and drained and dug and scraped year after year as they could spare the time from their farm work, improving the worst places as fast as possible with the facilities then at hand; but the desire and necessity for better roads grew faster than the roads could be built. But great things were accomplished, and in due course of time a good system of dirt roads was established throughout the country. Then came the desire for more of the comforts, and some of the pleasures of life! The "Old Studebaker Wagon," which had so well served the triple purpose of a pleasure (?) vehicle, a market wagon and a manure cart, would no longer do to carry the wife and daughters to church on Sunday. So the covered surrey made its appearance; and later, with increased prosperity the "boys" must have their "top buggy" and trotting-bred horse for their own private use after a week's hard work behind the plow.

Then the very plows themselves began to go on wheels—wheels for everything!

## The First Automobile.

One improvement after another followed in rapid succession. The mower came. Then the horse-drawn and horse-propelled threshing machine came along, asking for a more solid roadbed. Then, as if by magic, there appeared what we now know was a veritable and monstrous AUTOMOBILE threshing machine! It grew and grew, bigger and bigger each year, until it evolved into the enormous Traction Engine of to-day, which goes up and down over the face of the earth, pulling a "train of trailers" which fills the highways full of wheels from one fence to the other, and with noise and steam enough to scare the shoes off a horse less than forty years old. But, nevertheless, all this means real progress, and must not be stopped! It belongs to the spirit of the times! The wheels of progress should never be blocked, whether shod with rubber or rough-shod with ribs of steel. Progress must have a fair field and no favors.

Now to go back a little. The muddy, narrow, slippery dirt roads became obsolete in a day, as it were, and the great cry went up from every quarter: "Give us pikes—pikes! Give us more pikes!

Twenty years of incessant work on pikes has accomplished wonders. It is estimated that in Allen County alone there have already been built over 1,000 miles of pike roads. Think how many loads of stone that means—millions, perhaps. Then count the wear and tear on wagons, horses and men, and count the cost in dollars if you can. It is incalculable; but has all been done without a murmur. Of course, we still need more pikes, but the most important question which confronts us to-day is not so much that of building new pikes as the care and maintenance of those already in existence! During the busy days of new work, the old roads were scarcely given a thought, and many of them are now in sad need of attention. It is poor economy to allow a road to become entirely worn out, and have to practically rebuild it. The "stitch in time" doctrine is equally applicable to a turnpike or a pair of socks. For a short time a new road (as roads have been built in the past) will improve by use; but if not cared for a little each year it will soon begin to go backwards. The great aim in the past has been to see how many miles of new pike could be added each year—the old ones still serving to keep us out of the mud, the purpose for which they were originally built—so why complain?

## Rural Delivery Demands Better Roads.

But the large crops and high price of all farm products for the past few years, together with the general prosperity of the whole country, tend to increase the desire for the good things of this world, and affords more leisure to enjoy what we have. The increased number of people who ride over the country for either pleasure or business, to say nothing of the driving required by the great system of rural delivery which has so recently been inaugurated, have created a pressing demand from one end of the country to the other for a better grade of highways than have heretofore been dreamed of. Some roads will be built by the national government and others by the States, but the counties will always be the greatest promoters and builders of good roads.

Some States are already spending millions on their highways. Massachusetts appropriated \$25,000,000 a few years ago for that purpose and now has many miles of beautiful roads as smooth as asphalt pavement. All Europe abounds in fine roads; but they have been at it for centuries and have learned the art to perfection. It may take generations to put all our roads in as good condition as they are abroad, but we have made the beginning, and each year will doubtless show much progress as a whole. Even California is farther advanced in road building than we are in Ohio.

Here is what Geo. W. Lattimer, Chairman of the Joint Good Roads Committee of the Ohio State Board of Commerce and the Ohio State Grange, has to say on the subject of good roads in his recent report:

"The farther one studies and investigates this subject, the more he is convinced that it is one of the greatest problems of the United States. It touches the welfare and interest of more individuals than any other one question that is before the American public to-day. There is not a man, woman or child, in the country or city, that is not obliged to use the roads.

"Owing to the extremely bad roads of the present time, the farmer, who is the producer, is obliged to haul his product to the nearest market at such time during the year as the roads are passable. This occurs within two or three months in the fall, after harvest. This glut and over-supply makes the very lowest prices of the year for the producer, and the consumer in the cities and centers of population is obliged to pay the very highest prices during the months of the bad weather. Good roads will eliminate such conditions so that the farmer can haul his product to the market at any time during the year, whenever the demand calls for it, and the consumer can buy whenever the goods are wanted. Thus the producer will be able to secure a better price for his product and the consumer pays lower prices for his necessities.

"For years the United States and State governments have been appropriating money for waterways, steam railroads and other means of communication, all of which are good, but these questions become insignificant of what good roads will bring to the inhabitants of this country. Everybody should be interested in this question, and should urge Federal, State and county aid for improvements which at this time are all vital to the welfare of our country."

The subject is being agitated everywhere. It is in the very air we breathe, and, of course, good old Allen County is not going to be the least nor the last! We have abundance of good material. Granite, only, is superior to our native limestone for roadbeds or surface dressing. But we require a little more scientific skill in getting the best results from the material we have. It is a little crude in these latter days, to pile down a load of broken stone,

leaving them practically as they were dumped from the wagon, and expect to have even a passable road under a year or two—and all of it at the expense of worn-out tires and jaded horse flesh. And for all this wear and tear you have at best only three deep furrows to show for it—two where the wheels have run, and a sort of a "tow path" where the horses have been. We certainly have become too civilized to continue such a barbarous method of constructing a road. It was the best that could be done at one time; but now we have steam machinery especially adapted for the purpose, which leaves a new road in proper condition to receive a load of corn or a light top buggy.

Now, while the Lima Automobile Club is deeply interested in the general subject of new road construction, and is doing everything possible to promote such work throughout the State, we feel like repeating that the most vital question at this time is that of properly caring for the roads which are already built.

The most deadly enemy to good roads is water! Try and keep in mind this one fundamental thought, that water does more damage to roads than all other agencies put together! If it were not for water a road once good would always be good. Think about this every time you drive over a road speak about it to everybody you meet. Keep insisting that more attention be given to the subject of keeping water from standing in puddles along the road. It stands in pools only when there are holes for it to go into. No holes, no water! No water, no mud! One shovelful of gravel will fill a small hole, and if all the small holes are kept filled, there will never be any large holes!

#### The Care of Pikes and How "Chuck-holes" Are Made.

You can fill a thousand small holes for what it will cost to fill ten large holes. In one case you will have a perfect road all the time. In the other case you never had a good one. It is either holes or fresh stone the year round! But after a road has been properly built it is an easy matter to keep it so by watching for the small depressions which always appear in a new road, where little pools of water will accumulate after a rain. They look so very innocent and harmless at first; but the enemy—water—is there and at work! It softens the ground, and along comes a loaded team and forces out the water and some dirt with it—just a little—but the depression is made a little deeper and will hold a little more water than before; and the big wagon comes along again and "swishes" out more dirt with the water than it did the first time, and by continuing the process times enough a first-class "chuck-hole" is soon developed, which we begin to avoid by turning to one side. We keep edging away from it—one wagon after another—until we find ourselves in the ditch, where a second hole is created, and then there is no escape, and we must pull our load through some way. We mutter a little and then "jam-up" the horses, which must "grunt and take it," while they are nearly jerked off their feet by the pole and neck yoke.

This kind of thing is repeated many times over, in a greater or less degree during a day's drive over a pike three or four years old which has received no attention during that time. Wherever a drain-tile has been laid across a road you will always find a raise or a hole, even though it has been in for two or three years. Everybody sees it and takes the "jolt," but nobody fixes it, although it might be done in ten minutes, simply because it is nobody's business.

For the same reason when you approach a bridge you are compelled to pull your load up a six or eight-inch raise where the earth and plank come together, and then you must "jump off" at the other end of the bridge, and practically the same thing is also encountered at the numerous culvert crossings wherever you go. Because they have never been otherwise—always just exactly as you see them now—everybody has grown to think them all right, or at least they must be tolerated as something that cannot be changed, never realizing how fearfully abominable they really are!

#### Horse Sympathy.

The horse is rightfully an object of great sympathy among a large portion of the people who use him to perform different kinds of labor, but not a few are often unavoidably subjected to actual cruelty by their owners because of the un-beastly roads over which they must travel. But, fortunately, with an automobile there is no occasion for compassion. It can be sent regardless over the worst kind of roads without compunction, for a "thing of steel" knows no pain and can endure treatment without injury, which would ruin the animal made of flesh and blood, like ourselves!

Farmers are great spenders of money for every kind of "labor-saving" devices, but "Good Roads" is a better saver than any machine you ever bought. The greater loads that can be hauled, and the saving in wear and tear of horses, wagons and harness, the time saved and the additional comforts obtained are advantages enough to make everybody a "good road" enthusiast, and when once interested in the new order of things, you will think of and talk of little else until you have spread the gospel of good roads

from one end of the country to the other. The whole matter rests with the users of the roads. They get what they demand, and no more. If you protest against letting the old pikes run down, the authorities will certainly inaugurate a better system of maintenance. Certain men should do nothing but look out for and repair the old roads. Of course, it will take some time to put them all in good shape, but finally when they are gotten in order and are watched carefully, the cost in the long run will be far less than by the present system—or lack of system—and a thousand times more satisfactory to everybody.

#### Road Construction.

A few suggestions about the proper construction of a roadbed may not be amiss.

To begin with, the surface should be made VERY CROWNING, for it immediately begins to FLATTEN by use, and will continue to grow more and more so all the time if nothing is done to prevent it. But it can be held in good shape by occasional scraping. The scraping will also do a great deal towards filling up the small depressions, which are the real beginning of all trouble. But some new material must be carefully put in by hand where needed—not too much, as that will create two holes where before there was but one. Use more brains and less stone! A good road cannot be made without hard thinking. Keep in mind all the time that you are fighting water! You will notice that the roads always remain in the best condition on the grades where the water can easily run away, and you will also observe (after you become interested) that they always grow bad first in the valleys and level places, and that it is because the roadbeds are flat, or perhaps even hollowing with little dams of sod up on the sides so that the water stands there until it soaks in or dries up, instead of running away quickly, as it should, and would if the surface was kept crowning and the furrows kept from forming, which act as canals to conduct the water down into the lowest part of the road, where mud and destruction join hands in their evil work.

Thousands of little culverts may be found covered with loose or broken planks. They are a fearful nuisance and a source of danger all the time. You must bring your horses to a practical standstill before attempting to cross with a load, and if the old family horse is trotting along in a comfortable mood, he must be "jerked up" to a slow walk until you are safely over the danger trap. Along the valleys where the roads are level is the very place where trotting should not be interrupted. That is where the roads should be the very best, instead of the very worst, as they always are.

Either iron pipe, tile or stone or concrete arches should be substituted for every wooden-covered culvert in existence, just as fast as possible, allowing the solid earth roadway to continue along unbroken over them, but as they now are they are a menace to safe traveling and a relic of "old corduroy days," and should no longer be tolerated.

We trust no apology is needed to justify the sending forth of this little messenger. Its mission is to promote good fellowship and to draw attention towards the defects in our general road system and to encourage mutual co-operation in working out some means of remedying the trouble. There is nothing whatever deserving of censure or to complain about so far as the past is concerned, but rather everything to call forth the very highest praise possible for what has been accomplished. Our aim now is to try and anticipate some of the needs of the future and to provide for them in accordance with the demands of modern civilization.

#### Always Something Better Ahead.

There have been many epochs in road-making in this country, each one filling the necessity of the times when in vogue. But nothing is ever final! There is always something better ahead and we are ever trying to grasp it. Old ways are constantly yielding to the alluring promises of the future, and you are continually discarding old agricultural implements and replacing them with the very latest inventions; and still the end is not in sight. Road improvements will be no exception to the law of evolution, and before another decade rolls around there should be no better roads in the world than you will be riding over in Allen County. This is not uttered as a prophecy, but based upon the certainty that you cannot change your natures, and will continue in the future as you have done in the past.

We wish it to be most distinctly and thoroughly understood that there is no intention whatever of trying to convey the impression that there are no good roads in Allen County. That would be both unkind and untrue, for there are many miles that are almost as perfect as they can possibly be. And it is this fact which furnishes the greatest encouragement to push this work forward. If three hundred rods out of a mile are good, it seems only reasonable to suppose that the other sixty-five rods can, and should be, made just as good. Take a mile of perfect road, if you please, and scoop out a few hollows—make a hole or two—put in a culvert,

lay a tile across the road—and see what has happened. It has been transformed into a really bad mile of road, and still nine-tenths of the distance remains just as good as it was before; but, unfortunately, it is disconnected instead of continuous, as it should be for a practical road to travel over.

Good intentions are visible behind every move of the past, but after summing it all up we discover that the trouble rests upon the common fault of neglecting details, which in this case have been eclipsed by the desire to do too much new work.

Now, finally, after having the roads properly built—on paper, at least—let us consider

### The Etiquette of the Highways.

A little "frank and honest confession" will be good for us all. Comparatively speaking, the automobile is a new thing on our country roads, and it is not strange that at first there should have been a good deal of opposition to it by the drivers of horses. The man at the wheel was "green," and often had difficulty in managing the thing as he should, and the horses and drivers did not know what in the world to expect, and both sometimes nearly went into fits at the sight of the "red devils," as they were called; but both sides are fast becoming familiar with the thing, and many horses do not see an automobile any more. The time seems at hand when there should be nothing but good-fellowship between the two methods of travel. The question seems to hinge more on individual human nature than any universal desire to make an absolute lump condemnation of both the man and the machine. Courtesy or "cussedness" may come from either side, according to the make-up of the men themselves, regardless of which kind of "animal" they drive. Practically all those who now own machines were horse owners before, and if they are discourteous now they were when they drove the horse. Our nature is not shifted as easily as that. Some men, you know, always have great difficulty in being gentlemen at all times; some never succeed. And we feel like asking the horse men to make a distinction, and concede that a man could be a pretty decent sort of a chap although he does ride in an automobile.

As sure as the wheels of progress continue to revolve, our ranks will be recruited by the tens of thousands from the present owners of horses—and what if you should happen to be one of them? It would not make you bad, would it? Neither has it made any of us worse than we were before we changed (possibly some of us might have always been bad!).

To show how rapidly the automobile is coming into use, statistics show that in 1904 there were sold \$24,000,000 worth; in 1905, \$42,000,000; in 1906, \$60,000,000; and this year, \$80,000,000 worth. This is pretty convincing that they will supplant the horse for pleasure driving, the same as the modern reaper and binder has supplanted the "old cradle of our fathers" for harvesting purposes.

The gasoline engine is becoming a necessity on the farm. Every farmer will soon know how to manage a gasoline engine, and consequently how to manage a simple automobile. Eventually denatured alcohol will take the place of gasoline. The farmer will produce his own fuel; he will carry himself and his family around in his alcohol automobile; he will carry his goods to market or to the railroad station in the same way.

Now, under these circumstances, is it not best that all the information possible in relation to *The Etiquette of the Road* should be in the possession of those who travel? By carefully observing all the rules it will greatly lessen the chance of accidents and make everybody smiling friends as they pass by.

### Keep to the Right.

Centuries ago, convenience and custom decided what was the best rule for vehicles to observe in passing each other; and later the custom was enacted into a law declaring that we must "keep to the right," but through thoughtlessness there is a wonderful disregard of this rule by at least one-fourth of the people who drive

horses. They probably all know what the law is, but do not quite realize the great importance of a strict observance of it; although, as a matter of fact, nothing could be more vital. The safety of everyone hangs on never deviating from the rule—not once, even—(except by mutual consent for some good reason). When two horses meet, at a walk, it makes little difference what they do. But with a trotting horse and an automobile it is a very different matter. If both know, absolutely, what the other fellow is going to do, they can pass without danger; but if one driver is undecided as to what he had better do himself, and also entirely ignorant as to what the other one may do, there is likely to be some pretty sharp "dodging" when they come into close quarters—and there may be some swearing after the danger is all over with. This could and should be remedied; and will be as soon as everybody fully understands how very necessary it is that they do nothing else but just turn to the right! Keep saying it over to yourself—"turn to the right." Tell your wife and children about it. Warn them of the danger of doing otherwise, and in a little while it will become a fixed habit for everybody to turn to the right. When an automobile is coming up from behind and wants to pass, the driver will blow his horn in good time to give you warning. And in order that the automobile driver may know—dead sure—that you have heard the horn, you should immediately pull your horse to the right. Then the automobilist understands exactly what you intend to do, and you may feel perfectly secure that he will do you no harm whatever, provided you stick to the right side of the road! It is one of the remarkable, but common things, for the driver of a horse to change his, or her, mind as to which side of the road she (as it is more often women who do it) had better go, and will pull the horse first one way and then the other, and then when the automobilist thinks the matter settled and begins to pass, she suddenly concludes that the other side will be better after all. This is a source of great danger!

Instruct every member of the family on that point. Let them all read this little book. Warn them when leaving home to be sure to keep to the right!

The Lima Automobile Club cautions all their members on this point, and to be very careful when about to meet a horse, and if he is afraid, to either turn out as far as possible or stop his machine and lead the horse past it. We do this many times in a day, for we want to be humane, decent and courteous at all times; and above all, to cultivate your good-will and friendship, for we know that from now on we have to travel the same roads together, whether they be good or bad. We are far more anxious to avoid an accident than you can possibly be. We want to try to undo the prejudice against us, instead of aggravating it.

All automobilists are not members of our club, and perhaps all members do not always do as they should; but you may be sure that we do not sanction anything but true courtesy on the road, any more than you approve of some "piggish" horseman sticking to the middle of the road and refusing to give an inch—making the automobile take to the ditch while he is deriding us with bad language as we go by. Of course, he is an exception. But we are meeting that kind every little while, and no doubt some of the same kind of men are driving automobiles, but we trust that they also are the exception. That kind of men are devoid of all shame, but both sides must put up with them without lowering our standard of good behavior to each other. As before stated, it is all a question of individual human nature. And neither should be condemned as a class because of what some "bad pill" may happen to do. Always be right ourselves! Keep right, and keep to the right under all circumstances, whether you meet someone or someone wants to pass you from behind—and do it promptly and never change your mind! There is but one thing to remember—RIGHT! Turn to the right—STICK TO THE RIGHT—and you will always BE RIGHT.

Thanking you all for reading this little book, we are,  
Fraternally yours,

THE LIMA AUTOMOBILE CLUB.

## PENNSYLVANIA FARMERS BECOMING INTERESTED IN ROADS

YORK, PA., Jan. 6.—That the farmers are also taking an active interest in the good road crusade in this part of Pennsylvania is shown by the announcement that instructors of the State Department of Agriculture will speak on the making of good thoroughfares at the sessions of the Farmers' Institute to be held at Glen Rock, January 15 and 16.

Local autoists have been after the farmers for several years with the hope of encouraging the building of good roads, and they now feel that the latter are finally awakening to the situa-

tion. Many of the troublesome "thank-you-ma'ms" are disappearing from the roads in this section and in the new stretches they are being eliminated entirely.

These farmers' institutes are held in different parts of the county at regular intervals, and it is thought that the good roads question will come in for a great share of discussion and general approval before the sessions come to a close early in the spring. Every encouragement will be given to the farmers by local autoists, and special committees will attend the sessions.

# BRITAIN SEEMS TO LEAD IN NUMBER OF CARS USED

SEVEN nations of the world have created an export automobile trade of sufficient importance to justify a place in the financial returns of the government. Ten years ago neither France, America, Germany, England, Italy, Switzerland or Belgium had sufficient trade in automobiles to warrant government returns. In 1898 France, first of all nations, gave separate figures on automobile imports and exports, the latter attaining the moderate sum of \$337,000. Last year the industry had developed to such magnitude that it was sixth in national importance, only being surpassed by such staple industries as silk, wool, cotton and wines. For the first six months of the fiscal year 1907 French exports of automobiles, cycles and tires reached a total of \$19,400,000. It is estimated that for 1906 the exports of automobiles from the seven leading nations totalled \$42,000,000, the entire foreign trade, counting both exports and imports, reaching almost \$100,000,000.

Instructive figures compiled by *Commercial America* show that the United States comes second in volume of exports, the total

period covered by official returns, the value of the cars being quoted at \$10,000,000. Automobile parts reached a value of \$11,628,280, giving a total for complete cars and parts of \$21,628,280 for the eleven months. Calculating the importations of the remaining month at the same rate, this would give about twenty-four million dollars' worth of automobile exportations to England alone, being at the rate of \$60,000 a day. A small percentage of the exports to Great Britain would finally find their way to America and other countries, only being taken into England for re-exportation; these, however, do not figure separately in the official reports. It will be noted that during 1906 France imported for a greater value than any previous year, the total being very little short of 1904 and 1905 combined. More than one-half of these imports came from Germany.

### England the Greatest Buyer of Foreign Autos.

So great has been the demand for automobiles in the British Isles that the factories have been unable to keep up the supply.

## AUTOMOBILE IMPORTS AND EXPORTS OF SIX LEADING NATIONS.

	FRANCE		ITALY		UNITED STATES*		GERMANY		BELGIUM		GREAT BRITAIN	
	Imports	Exports	Imports	Exports	Imports	Exports a	Imports	Exports	Imports	Exports	Imports	Exports
1898	77,000	337,000										
1899	91,000	821,000										
1900	100,000	1,817,000	232,000	7,000	43,000							
1901	130,000	3,046,000	451,000	30,000	530,000	948,000	340,000	554,000	77,000	165,000		
1902	208,000	5,835,000	415,000	33,000	963,000	1,207,000	846,000	1,120,000	109,000	231,000	4,827,000	754,000
1903	244,000	9,811,000	541,000	112,000	1,294,000	1,805,000	1,197,000	1,259,000	101,000	254,000	8,340,000	1,387,000
1904	740,000	13,710,000	790,000	214,000	2,297,000	2,481,000	1,649,000	2,401,000	166,000	328,000	10,122,000	1,167,000
1905	835,000	19,351,000	1,261,000	510,000	3,844,000	3,497,000	3,132,000	3,307,000	201,000	756,000	11,874,000	1,830,000
1906	1,531,000	26,606,000	1,910,000	2,286,000	4,941,000	5,502,000	3,979,000	4,200,000	240,000	1,097,000	12,100,000	2,408,000

\*United States statistics are for fiscal years ending June 30th of following years. a United States exports include automobiles and parts

for the fiscal year ending June 30, 1907—the first year in which the value of automobiles is given separately from that of parts—being \$4,890,000. From the chart reproduced from our contemporary, it will be seen that the value of the exports of automobiles from France is greater than that of all other countries combined. Germany follows the United States very closely, Great Britain and Italy being some distance behind and Switzerland and Belgium far in the rear.

### Growth of the Industry in France.

A fair idea of the growth in importance of the automobile industry in the six most important countries can be obtained by reference to the accompanying table. It will be seen that France, the largest exporter, has steadily increased from \$337,000 in 1898 to \$26,000,000 in 1906. The latest returns, covering the first nine months of 1907, show automobile exports to the value of \$21,789,200, being an increase of more than five and a half million dollars over the same period of the previous year, compared with roughly \$2,800,000 increase from 1905 to 1906. Although the French increase in exports has been steady, and has maintained approximately the same proportions since 1903, it has not been as rapid during the last two years as that of some other European countries. Six countries imported more than one million dollars' worth of automobiles from France during 1906, as follows:

Great Britain .....	\$12,100,000
Germany .....	3,200,000
Belgium .....	2,900,000
United States .....	2,400,000
Argentine Republic .....	1,400,000
Italy .....	1,200,000

England, the most important customer of France, took 4,615 automobiles during the first eleven months of 1907, the last

The increase in imports of automobiles and parts since 1902 is shown in the following table:

		Cars.	Value.	Parts Value.
Imports..	1902 .....	3,747	\$5,376,000	\$540,000
	1906 .....	5,776	\$12,098,000	\$9,117,000
Exports..	1902 .....	415	\$754,000	\$82,000
	1906 .....	1,380	\$2,413,000	\$1,576,000

In addition to complete cars, Great Britain is also the largest importer of parts, the value of those imported during 1906 being double the value of the previous year. During the first ten months of 1907 the increase of automobile parts was two and a half million dollars more than the same period of 1906, two-thirds of these parts coming from France. Exports increased one and a half million dollars during the first ten months of 1907, two-thirds of the automobiles being sold to British possessions, India, Australia, New Zealand and South Africa taking large quantities. Among foreign countries the United States, Argentina, Italy, and France were the largest buyers.

In Germany the value of the imports of automobiles has steadily gained upon that of exports, until 1906, when they were about equal. During the first nine months of 1907, however, the imports increased and the exports fell back, so that Germany will import more this year than it will export. The valuation of automobiles according to the German tariff is 10 marks per kilogramme for motor carriages and 4 marks per kilogramme for commercial wagons. This is the only nation that makes the distinction between these two classes of vehicles. Three-fourths of German imports came from France. Great Britain stands first in imports from Germany, the value largely being made up of automobile 'buses and other classes of commercial vehicles. In the first nine months of 1907 Germany imported 1,559 auto-



mobiles, valued at \$3,500,000, of which 31 were commercial vehicles. During the same period it exported 995 automobiles, valued at \$2,793,000, of which 221 were commercial vehicles. There has been a falling off of \$400,000 in the value of exports and an increase of \$320,000 in the value of imports over the same period of 1906.

**Greatest Recent Increase Made by Italy.**

Italy has made greater proportionate advances in the value of automobile exportations during the past two years than any other country, the exports being quadrupled from 1905 to 1906. Around Turin especially, the increase has been tremendous, the Italians claiming equal importance for this district as Suresnes and the neighboring suburbs of Paris, or the city of Detroit. From \$7,000 in 1900, an increase of exports has been made to \$2,286,000 in 1906. Belgium, in 1906, first passed the million-

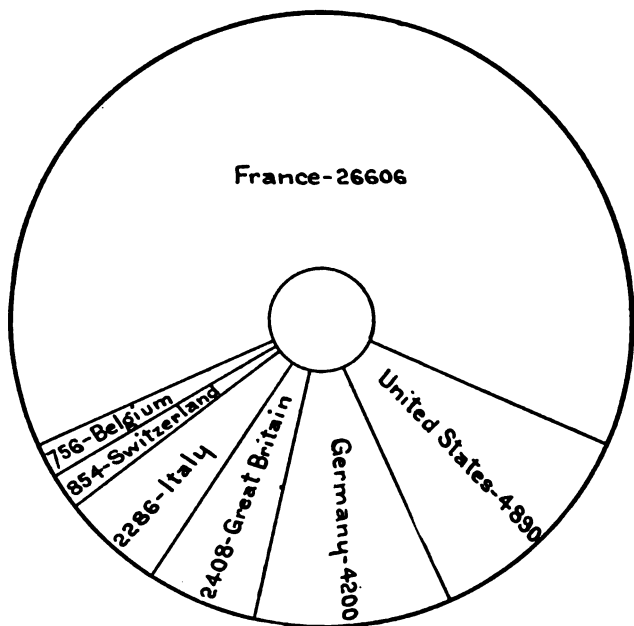

**EXPORT OF AUTOMOBILES FROM SEVEN LEADING NATIONS.**

Total value, 1906—\$42,000,000. Value in thousands of dollars. 000's being omitted. The value of exported parts is not included in the chart.

dollar mark in value of exportations, with a promise of further increase. Its imports are small and do not show a tendency to increase.

**The Story of a Stupendous Home Growth.**

America's story of increase has to be presented on the basis of the national output, on which lines it is as astounding as the export figures presented by France. These are to be found in the various census returns, from which it is seen that there was an increase in the value of products of 461 per cent. between the census years of 1899 and 1904. Regarding 1907, estimates only can be made, but even on a moderate basis they show a progress that is unprecedented for an industry which hardly existed ten years ago. The two census returns and the estimates for 1907 and 1908 show a substantial growth as follows:

American production, 1900.....	\$4,748,000	
" " 1905.....	\$26,645,000	21,692 cars.
" " 1907.....	\$80,000,000	40,000 cars.
" " 1908.....	\$100,000,000	50,000 cars.

In addition to the automobiles of home production there must be added those received from foreign countries, the returns for the years 1901 and 1907 being:

Imports, 1901.....	\$43,129	26 cars.
Imports, 1907.....	\$4,041,000	1,176 cars.
Imports, 1907.....	\$801,000	parts only.

Of the cars received during the past year 841 were from France, 144 from Italy, 104 from Great Britain (these being

largely composed of re-exported cars), 61 from Germany, and 27 from other countries.

It is somewhat difficult to compare the American industry bulk for bulk with that of any other nation, for while the importance of every foreign nation depends on its export trade, and official figures deal only with cars sent abroad, American census returns deal with the industry as a whole. French imports will reach \$27,000,000 in 1907; placing the value of the home consumption at the same figure—a generous estimate—this would give a production value for France of \$54,000,000. Great Britain, according to general estimate, will produce automobiles to the value of \$25,000,000, making a total production of \$79,000,000 for the two most important countries of Europe. Thus the American production for the past year has been, if not greater, at least equal to that of France and Great Britain combined.

Most significant in this story of growth is that the United States has attained a position in the export world second only to that of France, the number of cars sent abroad in 1907 being 2,862, valued at \$4,890,000. In the chart of the exports of automobiles from the United States by countries, the value of the parts is also included. This amounts to \$611,000 for all countries. From this chart it can be seen that Great Britain is the largest purchaser, followed by the British colony of Canada, these two alone taking nearly one-half of all the exports from the United States. Concurrently with the growth of the automobile industry has sprung up a considerable export trade in metal-working machinery, every factory in France, Italy, Germany and England being stocked with American-made machine tools.

In 1900 the leading automobile manufacturing States were Illinois, Massachusetts, New Jersey, New York, Ohio and Pennsylvania. In 1905 Michigan alone made more automobiles than the whole country in 1900; the same was also true of Ohio. There is a strong tendency, too, for the American automobile industry to group itself in large cities, eighty per cent. of the products of the industry being credited to cities of over 20,000 population, 86 establishments out of 121 being in these cities. The leading cities with the value of their output, as given by the census, are as follows:

Detroit .....	\$5,382,000
Cleveland .....	4,256,000
Buffalo .....	1,385,000
New York .....	1,186,000
Indianapolis .....	797,000

**England Leads in Number of Autos in Use.**

Contrary to general supposition, it is not the United States but Great Britain which leads in the number of automobiles in use. The figures of France, which come fourth in importance, are always conservative, the returns being based on the number of automobiles actually paying tax based on horsepower. Manufacturers' and dealers' stocks are not declared for taxation purposes; cases of double taxation are exceptional, and there must be a number of rarely used machines in repair shops and elsewhere which escape the official returns. French figures thus comprise only those machines in actual daily service. British returns, being based on registration giving no encouragement to false returns, may be taken as perfectly reliable. The American figures are based on estimate, no complete returns for the whole of the States of the Union being available, and even those making returns being not altogether correct, owing to duplicate registration. The returns for the year 1907 in the four most important countries are:

Great Britain .....	119,618
United States .....	80,000
Germany .....	42,980
France .....	31,286

In the figures for Great Britain are included 53,877 motorcycles; Germany's fleet of two-wheelers included in the total amounts to 15,700.

## LETTERS INTERESTING AND INSTRUCTIVE

### USING A SINGLE COIL ON TWIN ENGINE.

Editor THE AUTOMOBILE:

[1,074.]—We would like to know if we can use a single spark coil—a Splitdorf—on a double-opposed engine to work all O. K.? Give us full instructions as to how to wire same for a four-cycle. Also the proper way to pipe up the water so it will work right through both cylinders at one time for above engine. The coil is a vibrator dash style. A SUBSCRIBER.

Canton, O.

Assuming that you now have an engine wired up to use two vibrating dash coils, the only changes necessary are to carry both wires from the timer to the single coil you propose to use and take two leads from the secondary, or high tension, side of the coil, one to each of the spark plugs. This will cause a spark to occur in both cylinders every time contact is made and as long as one plug does not present any materially greater resistance to the passage of the spark than the other, both should spark without imposing any extra duty on the coil. The battery is connected to the primary, or low tension, side of the coil in the usual manner, the other side being grounded; that is, attached to some part of the motor, or of the car near the motor, while the same is done with one side of the secondary to form the usual ground return in each case. This is the simplest method available, and while it may work satisfactorily for a long time at a stretch, it is not the best method to use. For the latter, the timer at present on the engine should be removed and a distributor substituted. This may be had from any dealer in ignition accessories. It times the low and high tension currents simultaneously and the connections are very simple, the following being the complete wiring: One wire from battery to low tension side of coil, second wire from battery to ground, i. e., on motor or frame; one wire from primary of coil to distributor, second wire from low tension side of coil to low tension side of the distributor, this being plainly marked on the latter, as are also the secondary connections. One wire from secondary side of coil to distributor; one wire from each of contact points of latter to each plug; second wire from high tension side of coil to ground connection.

The piping for the water circulation of the motor should be so arranged that the cold water enters each cylinder at the same temperature and leaves it at the same temperature. That is, instead of running the water into the jacket of one cylinder, and from there into the jacket of the second cylinder and then back to the radiator, it must be piped from the radiator directly into both jackets, and from the latter back again. A single pipe suffices for this in each case, branches being made just at the motor. A three or four-inch section of good rubber hose should form part of both the cold and hot water pipes in order to provide for any relative movement of the radiator and the motor, as otherwise the pipes are apt to be snapped apart by the jolting.

### ONE CARBURETER WILL WORK BETTER.

Editor THE AUTOMOBILE:

[1,075.]—We have an eight-cylinder 5 by 5 1-2, four-cycle light auto engine with two 1 1-2-inch carbureters on it. Is there any reason why one carbureter won't work just as well as two?

Haverhill, Mass.

HAVERHILL PASTE CO.

Probably you will find that removing one of the carbureters now on the motor and devolving the entire duty upon the one remaining will give better results than formerly, provided that the carbureter has sufficient capacity and that the manifold be arranged in the proper manner. All the eight-cylinder motors we have ever seen have never been equipped with more than one carbureter.

### SIMILAR TROUBLE WITH COPPER TANK.

Editor THE AUTOMOBILE:

[1,076.]—I read with considerable interest question 1,028 with your reply under "Letters Interesting and Instructive" in your December 19 issue, as I had a similar experience with the gasoline tank in my car, with this difference: In my case the scale or flake which formed in the gasoline tank and clogged the outlet and feed pipes was BLACK. The tank in my car is made of copper instead of galvanized iron, but I have been unable to discover the reason for the existence of the scale, as I have been very particular about the quality of the gasoline used and always strain it through a chamolis. A. H. LANDSBERGER.

San Francisco, Cal.

Several replies have already been received from subscribers and some of them published in this department regarding trouble of the nature described by Dr. Tuttle in the letter which opened this line of inquiry. But thus far, without exception, each one of these answers from autoists in different parts of the country has ascribed the cause of the precipitate to the employment of galvanized iron for the tank, and in one case at least it is stated that the substitution of copper for the fuel container proved an entirely satisfactory remedy both in a motor-boat as well as on an automobile. The fact that in the present instance the usual copper tank is employed puts an entirely new aspect on the matter, and with the exception of the indication that the color of the scale or formation points to some chemical combination of a constituent of the fuel with the metal of the tank, we must confess our inability to state just what the reaction between the two is, as well as the nature of its product. However, as numerous engineers, chemists, physicians and other technically skilled men are to be found among the subscribers of THE AUTOMOBILE, we have never failed in the past for lack of responses of the most satisfactory nature to even the most abstruse questions of any nature, and feel confident that an appeal for information in the present instance will prove no exception to the rule. We should be pleased to hear from any autoist who has experienced similar trouble, or who knows its origin, whether he happens to be a subscriber or not, the matter being one of considerable general interest.

### REDUCING THE GEAR RATIO OF A CAR.

Editor THE AUTOMOBILE:

[1,077.]—I bought a runabout and want it changed to a touring car with semi-limousine top. I want to find out how I will gear my sprockets down. I have thirty-seven in the rear and twenty-four in the front, which I know is too high for a touring car. I want to gear it down to about 4 to 1. Please let me know the best way to gear this down. I have thirty-six-inch wheels.

Baltimore, Md.

R. B. FIELDS.

In order to be able to reduce the gear ratio of your car to the desired point, it is essential to learn just what it is now, and the data concerning the sprockets alone is not sufficient for this owing to the reduction at the bevel gearing on the countershaft. With the car on a smooth, level floor, turn the engine over until the piston of the first cylinder is about to start downward on a power stroke. Make a mark on the flywheel and on some part of the motor alongside of it so that the revolutions of the flywheel can be counted. Then make similar marks on the tire of the rear wheel where it touches the floor, and on the floor itself directly beneath it. With one man to watch the flywheel and another to keep an eye on the mark of the rear wheel, push the car forward in a straight line, having set the change speed lever at the point corresponding to the high speed or direct drive before starting. A revolution of the engine should be counted every time the marks of the flywheel and motor coincide, and the car should be halted the moment the chalk mark on the tire again comes down to the floor, thus completing one revolu-

tion of the driving wheel. The number of turns the flywheel has made during this time will give the gear ratio of the car. Unless this is found to be higher than 3 to 1, we should hardly advise changing it merely on account of the weight of the touring body. You do not state the power of the car, but as it has 36-inch wheels, we judge it to be of 30 horsepower or over, in which case the extra weight would not affect anything more serious than a slight reduction of the speed. If the present gear ratio be 2.5 to 1, it would be advisable to lower it by using smaller forward sprockets. The present ratio of the sprockets alone is 1.54 to 1, i. e., the forward, or driving, sprocket makes a turn and a half for every turn of the driven sprocket. Either a 20 or an 18-tooth forward sprocket, giving reductions of 1.85 to 1 and 2.05 to 1, should prove satisfactory. Unless the car has but small power for its weight, it would hardly be advisable to gear it as low as 4 to 1.

#### CONCERNING KEROSENE AS A PREVENTIVE.

Editor THE AUTOMOBILE:

[1,078.]—Will you please publish under "Letters Interesting and Instructive" at what temperature kerosene boils. I tried kerosene in place of water to cool my engine with, but it is not altogether satisfactory. It circulates and the radiator does not get very hot, but the kerosene will smoke and "steam" on about a half hour's run. The other objections are that it is so dirty to handle and gives off a bad odor.

Please give name of some tester or instrument that could be used to tell the density of a calcium chloride solution. What should it read to stand 15 below zero? I am afraid to use a solution of it now, as I do not know where it would freeze at.

Oregon, Ill.

F. R. ZEIGLER.

Kerosene distilled from different grades of petroleum differs more or less, the same as gasoline, but its boiling-point will be found to average between 180 and 190° F., according to its specific gravity. It is far from being a satisfactory substance to use in the cooling system of an automobile, even if it were not burdened with the disadvantages of a low boiling point and an offensive odor. We should think its use would be more or less dangerous, at it becomes highly inflammable when raised to this temperature and also gives off an inflammable and explosive vapor.

A hydrometer is employed to test the density of a solution, and when ordering it the nature of the solutions with which it is to be employed should be stated, as these instruments are made for numerous special purposes. We have no data at hand as to the density of calcium chloride solutions to prevent freezing at stated temperatures, but you can easily ascertain this for yourself without any trouble. The proportion of four pounds of calcium chloride to the gallon of water, gives a solution that will resist freezing down to slightly lower than 15 below zero F. Having prepared this, test it with the hydrometer and mark the latter at the point on the scale to which the instrument sinks in it. If loss from steaming or evaporation is feared, the hydrometer may be dropped into the solution in the radiator from time to time and if it shows that it is becoming heavier by allowing the instrument to float higher, add sufficient fresh water to restore its former specific gravity. The solution should be tested for acidity before being placed in the radiator by dipping a piece of blue litmus paper in it; if the paper turns red, a small amount of slaked lime should be added, until the paper shows no reaction, a fresh piece being used each time. Get the best calcium chloride obtainable, as the crude salts are apt to contain considerable free acid.

#### IS A NEW CARBURETER THE BEST CURE?

Editor THE AUTOMOBILE:

[1,079.]—I should appreciate your opinion on the following: I am driving a 1907 Maxwell runabout and have been thinking for some time that perhaps I could get better results by installing a "Holley" carbureter. Perhaps the fault lies with me in not being able to get the proper adjustment with the present carbureter.

My motor misses considerable with the spark advanced and gas all on, batteries and vibrator in good shape. J. A. SPOONER.  
North East, Pa.

So many autoists, when they find themselves in a similar predicament, never appear to stop to ask themselves whether the device they are belittling has given satisfactory service prior to that time. It may have covered thousands of miles on the car with little or no trouble, but once the latter does come to afflict them their first thought is replacement of the offending article. We do not know whether this happens to be your case or not, but the practice is quite common and must, in numerous instances, lead to an unnecessary outlay for new accessories. The makers will doubtless be glad to assist you in every way possible, and we should advise consulting them as to the proper manner of adjusting the carbureter before making a replacement.

#### TO MAKE GASOLINE MORE EXPLOSIVE.

Editor THE AUTOMOBILE:

[1,080.]—Please answer through "Letters Interesting and Instructive" what is it they put in gasoline to make it more explosive, or have more power, and would it be safe to use it in a car? How much to the gallon?  
A SUBSCRIBER.

Portsmouth, O.

Picric acid is the material that has been employed on various occasions in racing to increase the power of the motor, and while it is said to accomplish this end successfully, it is not a safe thing to use from more points of view than one. The quantities employed are small, something like two per cent., we believe, although we have no data on the subject; but in addition to the risk of ruining the motor through the production of explosions far more powerful than it was ever designed to stand, it must be borne in mind that picric acid is commonly used for etching steel, and even though present in small quantities, it is apt to have this same deleterious effect on the cylinder, valves and other parts of the motor with which it comes in contact. Oxygen and acetylene gas have also been employed at different times to make a motor more powerful than it would otherwise be on ordinary fuel. Such expedients are never to be recommended for anything but racing, and they have but scant justification for existence even in that field. The autoist who values his motor should let them severely alone.

#### A STAND FOR "RESTING" THE TIRES.

Editor THE AUTOMOBILE:

[1,081.]—Some two or three years ago at the automobile show in Boston, I saw a certain stand that you could just run the machine on and that would raise it to rest tires, four wheels at one time. Could you please let me know the firm's name, if the concern is still doing business?  
PHILIPPE SYLBESTRE.

Woonsocket, R. I.

We believe that the device you have reference to is known as the "Autobed" and that it is still manufactured by a concern of the same name, located in Boston, i. e., the Autobed Company, 36 Columbus avenue, Boston. If this be not the article you have in mind, a further inquiry in these columns would doubtless elicit the desired information from some of our subscribers, many of whom seem to have wonderful memories where such things are concerned.

#### MACHINING THE COMBUSTION CHAMBER.

Editor THE AUTOMOBILE:

[1,082.]—Why is it that most gasoline motors produce a definite recurrent beat in the sound of their running, which appears to correspond with the number of cylinders the engine has—that is, with a four-cylinder motor, for example, every time four cylinders have fired the beat occurs. I do not know how to describe any better than this what I mean, but am sure that you must have noticed it yourselves. I figure that there is no reason theoretically why a single or multi-cylinder motor should not, when running right, produce an even, regular sound of perfect, unchanging rhythm, and a few motors do so, but the generality of them show the marked

pulsation I speak of. If you or any of your readers can explain this, I am sure that I, among others, will appreciate acquiring the information.

Toledo, Ohio.

We all have noted the effect you speak of, now that our attention is called to it, and it is the consensus of opinion in this office that failure to machine the combustion chambers, with consequent variation in compression between the different cylinders, is the cause. It is practically impossible to secure perfect uniformity in castings, so, in motors the compression clearances of which are left as cast, a variation in compression and completeness of exhaust, with consequent variation in power and the intensity of the exhaust noises, is produced. This would readily explain the reason for the "beat," which is simply a perception of a regularly recurrent sound, louder or softer than the rest. If any one else has any other or better theory to suggest, however, we shall be pleased to give space to it.

### INFORMATION WANTED ON FOUR-WHEEL DRIVE.

Editor THE AUTOMOBILE:

[1,083.]—Would you be kind enough through the columns of your paper to give me some information regarding four-wheel drive motor wagons, built in Milwaukee, Wis.; why they are using a main differential; I understand when one wheel is skidding or in a hole, then you are practically helpless. What would happen if one of either front or rear wheels got stuck; your power would not be available for either front or rear wheels. If your main differential was not there, it seems to me unnecessary for the low speed obtained with them to employ any differential between the two driving points.

St. Paul, Minn.

P. S. SANDERS.

We are not sufficiently familiar with the design of the truck in question to be in a position to answer your question intelligently. It is our impression that these vehicles are no longer being built for the market, but as quite a number of them were doubtless turned out, there will be in all probability at least several of our readers who can throw some light on the subject covered by your line of inquiry. If so, we will be pleased to hear from them.

### GEAR REDUCTION OF THE PACKARD ON HIGH.

Editor THE AUTOMOBILE:

[1,084.]—Will you please answer the following questions in "Letters Interesting and Instructive":

1. What is the gear reduction on Packard "30," 1907?
2. What is the gear reduction on Packard "30," 1908?

Saratoga Spa, N. Y.

CHARLES HESLIN.

The gear reduction of the Packard on the direct drive is 3 to 1, on both the models you mention, as well as on the one that preceded them, namely, the 1906 model.

### CONSIDERS ARTICLE RATHER "THEORETICAL."

Editor THE AUTOMOBILE:

[1,085.]—We have read the article on lamps, issue December 12, with some care. In general, we would say someone had written the article who is not connected with the industrial side of the question, and is "theoretical" rather than "practical."

Passing to specific criticism, we note that the use of the electric arc and the Nernst lamp is suggested. The smallest practicable size of the former takes about a fifth of a horsepower, and the latter from about one-seventh of a horsepower upwards, and in both cases there is the generating machinery to be considered. Most of us cannot spare so much power for lighting, and nobody wants the added machinery, so that the future for either of these illuminants for motor car purposes is not promising, except, of course, where a storage battery is the motive power. "Theoretically," we suppose they are all right.

The writer's definition of mean spherical candlepower is incorrect. Mean spherical candlepower is not a total, but an average; and is obtained by measuring the candlepower in a dozen or more directions (theoretically in all directions) and taking the average of the results. The term arose in connection with the measurement of incandescent and arc lights, or at least assumed importance in that connection. With flames such as acetylene, which give practically the same illumination in all directions, the mean spherical candlepower is nearly the same as the candlepower in any one direction. Fig. 1 of the paper means nothing.

The writer's figure of 12 per cent. as the available percentage of light in the arrangement of Fig. 2 is correct, if the box does not reflect any. He is also right in saying that the mirror in Fig. 3 converts into a parallel beam 12 per cent. of the total emitted by the flame. We measure the angle subtended by the mirror in Fig. 4 as  $140^\circ$ , and this makes the percentage falling upon the mirror  $34.2^\circ$ , and not  $37^\circ$  as he finds, but this difference is not material.

Figures 2 to 7 appear to be correctly drawn, but the argument based upon them rests on three assumptions which are by no means admissible without pretty definite proof, a part of which must be drawn from experience. The first assumption is that the law of inverse squares holds under all conditions. He makes this statement in the third paragraph, and it is not true for reflector lamps except beyond very great distances, several hundred feet or more; perhaps not even then. Inside this limit the law of inverse squares is not applicable, and a photometric measurement of such a lamp against an open light as a standard is absurd.

Incidentally, the calculation of candlepower in the last paragraph is equally absurd. To show this, just draw a sphere in Fig. 7 with twice the radius of the one pictured. The beam D E will cut the larger sphere, and will be of the same size and consequently of the same brightness on it. But if it cuts out one-fiftieth (taking the figure given, which is probably correct) of the smaller sphere it will cut out only one-fourth as much of the larger one, and hence its candlepower would be 25 divided by one-fourth of one-fiftieth, or 5,000. This is a charming way of computing candlepower. You can get anything you please by taking a suitable radius for the sphere. We think you are familiar with our opinion that candlepower of reflector lamps means nothing. All that can be said is that such a lamp at such a distance gives as much light as would be thrown in the given direction by an open lamp of such-and-such candlepower; and as this value will change with every change in the distance, it is of very little use as a basis of comparison.

The second assumption which we think is by no means justified is that light not concentrated into a parallel beam is wasted, a statement the writer makes in so many words. If your lamp throws out a cylinder of light of the diameter of the front glass you will have brilliant illumination along this cylinder, and nowhere else; and if such a lamp could be constructed it would be of no practical use on the road, where the conditions are not those confronting the commanders of war-vessels or locomotives. Hence we take decided exception to the statement that the lamp of Fig. 6 has a net efficiency of only 88 per cent. We think all the light is utilized, and very well. In the case of Fig. 5, our opinion is that only the zone DC (IJ on the other side) is wasted, all the rest being usefully employed so that the efficiency of this lamp would be considerably above 50 per cent. The fact that the source of light is not a point prevents the attainment of perfectly cylindrical beams, and so the advantage of the slight divergence of the beam from the mirror is not seen at its best; but to our thinking the "fan" distribution is an indispensable part of the illumination.

The third assumption to which we take exception is that there is no absorption, either by the reflecting surfaces or by the lens of Fig. 7 or its mounting. He does mention the necessity of keeping the surfaces polished, but he omits to state that unless they are kept in perfect condition his figures are incorrect and the conclusions from them vitiated. A good mirror will reflect 92 to 95 per cent. of the light falling upon it; a poor one may send back anything less, down to almost nothing if the mirror is behind a smoky flame. How close to the mirror a hot flame can be placed without damage to the reflecting surface or deposit on the glass, we know by experience, but from such examples as we have seen on the road we have come to the conclusion that more is lost by imperfectly reflecting mirrors than is gained by a very large cone of intercepted light.

GRAY & DAVIS.

Amesbury, Mass.

### "CRY GOOD ROADS FROM EVERY HOUSETOP!"

Editor THE AUTOMOBILE:

[1,086.]—Will you allow an assiduous reader of "The Automobile" to make a comment on that most illuminating article, entitled "Learned in the Process of Evolution," by Charles B. Hayward, in the issue of December 6. Certainly a fairer, more generous article was never written, but may not some of the supposedly constructional vices of the modern automobile be laid at the door of the reckless, unintelligent conductor, and again to bad American roads? You can't escape these things merely by making automobile parts which allow an extraordinary margin of safety. This element may already be said to exist in most modern automobiles. Foreign cars, of which the writer knows something in a general way, French cars in particular, are certainly not—in most instances—ill designed or ill made, and the fact that high-class, well-known French "marques" do occasionally go to pieces on American roads is rather an indictment of those sloughs of despond than the type of car which has been run for tens of thousands of kilometers over



French roads with never so much as a cotter pin shaking loose or a nut having been started from its seat. Even that little Pekin-Paris affair brought out no serious structural faults that could not be well guarded against by an intelligent and painstaking and careful driver, and certainly no other kind ought to be let loose on the highways.

I am told that the bad roads in America necessitate a relatively high horsepower to get over the ground at all, to say nothing of making "la vitesse." This means, then, a relatively high cost product to begin with, and again a costly consumption of gasoline—and shall we not also include pneumatics? Cut it out; go to the roots; cry good roads from every housetop; not only good roads to begin with, but agitate for national support that shall help in the making of them and in their upkeep.

Even France, the most paternal of governments, in all things, is now studying the question as to what kind of good roads are best suited to the new class of traffic which goes over them in automobiles. The Romans and Napoleon did very well, but Republican France promises to do something even better. Shall Republican America remain behind with the buggies? The writer thinks not!

FRANCIS MILTOUN.

Martigues Bouches du Rhone, France.

### TAKES ISSUE WITH MR. FAY ON NEEDLE VALVE.

Editor THE AUTOMOBILE:

[1,987].—I cannot refrain from sending you a line to take issue with Thos. J. Fay on his dictum condemning the adjustable needle valve, in his otherwise admirable article on the carbureter in your issue of December 26, 1907.

I am now driving and taking entire charge of my fifth automobile, and I am free to say that I would refrain from purchasing any car which had a non-adjustable gasoline nozzle. The car which I am now driving, one of the highest powered American cars (30 to 60 horsepower), had a double carbureter in which both nozzles were without the friendly old needle valve; the only possible adjustment being some movable slots for the control of the air. After a few weeks' trial the agents consented very courteously to take this carbureter out altogether, and to substitute for it one in which both nozzles had the familiar needle regulating valve. The change in the general behavior of the motor was magical. I can now keep the motor running to the best advantage under all varying conditions of temperature and humidity; and can do more good with a quarter turn of one of the needle valves than could be accomplished formerly with an hour's tinkering at the air supply. The manufacturer of the car wrote me a polite letter on the subject, saying that he had adopted the non-adjustable gasoline nozzles because he had found a tendency on the part of inexperienced purchasers to get the adjustable type of nozzles out of order.

I think the trusting too much to automatic mechanical action on the part of manufacturers is an error; since often in making a machine "fool-proof" (insulting phrase) the tendency is to produce a machine which, while it will run tolerably well for everybody, will never run just right in the hands of anybody. The average owner of an automobile is an eager student of mechanical principles, and it seems to me that each year he grows fitter to be trusted to make those small daily adjustments, which are necessary if the motor of an automobile is to do itself full justice.

Philadelphia, Pa.

A. S. LOGAN.

### SHOULD DRIVERS NOT BE SUBJECT TO TESTS?

Editor THE AUTOMOBILE:

[1,988].—While attending the recent automobile show in Chicago, I had the misfortune to be in a car when an old street sweeper was knocked down and almost run over. Luckily he was not hurt seriously, although it was necessary to take him home in a carriage. This happening so completely finished my desires for demonstrations, that it was the only ride I took while in Chicago. We were turning slowly around on Michigan avenue to return to the Coliseum, with no power on, when the old fellow suddenly appeared directly in front of us. The boy driving had plenty of time to stop, but did not seem to know how; and that was the awful part of it. He did not know how to stop his car even when only running free and very slowly, and yet he was trusted with the lives and limbs of prospective customers, to say nothing of numerous pedestrians. And he actually confessed that he had never driven an automobile of any sort until the Friday before the show. With one day's experience, he was sent out to steer a car through the crowded avenue. Not to mention the foolhardiness of a firm in using such a boy for that purpose, does it not seem that some means should be used to put a stop to the use of automobiles by any one with so little knowledge of them? I wish I could stir up something or somebody to get some legislation on this subject, but realize that I have not the ability. However, you, through your excellent journal, should be able to at least start the thing, and it is a serious question.

FRED. L. MORGAN.

Alliance, O.

### ANOTHER EXPLANATION OF THE SCALE.

Editor THE AUTOMOBILE:

[1,089].—In reading over your "Letters Interesting and Instructive," I was interested in Dr. Edward G. Tuttle's letter, No. 1,028, in which he states that a peculiar formation in his galvanized gasoline tank gave him considerable trouble. Explaining my experience with a galvanized tank in a gasoline launch last summer, I was troubled with a dark black scale which would run down the pipe line and clog up the carbureter. Upon close examination of the tank I found that I could pick off a dark scale where the seam had been soldered, which was probably caused by the uncut muriatic acid which was used for soldering same.

After I had remedied this I still had trouble with my carbureter choking up with a dark substance, but was much different from the tank scale. I afterwards found out by taking out my pipe line, which was ordinary gas pipe, and tapping it with a hammer, that I got as much as an ounce of black iron scale which had formed inside of the pipe after being in use for about three years. I would pronounce this scale a sort of rotted iron.

Hoping that Dr. Tuttle will find the experience useful, I remain,  
Springfield, O.

R. D. VERCLER.

### DRY CELLS FURNISH SATISFACTORY SERVICE.

Editor THE AUTOMOBILE:

[1,090].—Regarding query No. 1,052, would say that I became interested in ignition difficulties by Arthur F. Jackson's article on that subject in the May 23, 1907, number of your magazine, and also in that of a paragraph in the "Automobile Instructor," which says that "it is impossible to adjust a coil advantageously to battery consumption and correct ignition by the sound of the vibrator." I accordingly purchased a coil current ammeter and regulated the current of my coil to that of a 3-4-ampere strength, to do which I was obliged to weaken the vibrator springs besides the usual regulation by the screws. After so regulating I ran my car 1,600 miles on five dry cells and with the same spark plugs. I occasionally tested the current with the ammeter, but no regulation was required until the batteries became nearly exhausted, upon which I replaced them with new ones. So far as my experience goes, I can heartily endorse Mr. Jackson's statement that dry cells when used intelligently furnish a most satisfactory ignition. I think his article would be worth reprinting for the benefit of your new subscribers.

H. W.

Worcester, Mass.

### HAD TO SUBSTITUTE COPPER FOR THE TANK.

Editor THE AUTOMOBILE:

[1,091].—Replying to inquiry No. 1,028, regarding the yellow precipitation occurring in galvanized gasoline tanks, I have had the same experience. Some years ago I ran a launch on Long Island Sound and had the same trouble, although the stoppage was not at the mouth of the gasoline outlet. In my case the precipitate entered the carbureter, but the result was the same—the engine stopped. I remedied the difficulty for the time being by putting in a through way between the tank and carbureter and using the attached pipe as a catch-basin. It was only a makeshift, and fearing the corrosion might continue until a hole had been made in the tank, I finally removed the latter and substituted a copper tank.

Several automobile manufacturers use galvanized gasoline tanks, and some time ago I wrote to the Lambert people asking them if they had ever any trouble such as described above, and they replied that they had not. I wonder if the precipitation is due to the salt air, and that away from the sea it would not occur?

Would like to hear the experience of others.

Easton, Pa.

R. K. B.

### VALVE STEMS THAT REQUIRED LUBRICATION.

Editor THE AUTOMOBILE:

[1,092].—With reference to query No. 1,035 on Valve Stem Lubrication, in reply to O. A. Weiss, I wish to say that during the summer of 1907, I ran a car on which valve stem lubrication for the exhaust valves was absolutely necessary. If not lubricated, the exhaust valves in the rear two cylinders, and occasionally in the others, would at first "snap" slightly, then louder, and finally if not attended to would stick, sufficiently to cut out the cylinder affected. A liberal application of lubricating oil applied while the motor was running always cured the difficulty. If I had kept the car for another season, I believe I would have fitted grease cups, if possible, to avoid the frequent oiling. I believe, however, this is a fault of this particular make of motor, and if properly designed lubrication would likely not be necessary, as this is the only car that I have seen on which this has been the case.

Brooklyn, N. Y.

LOUIS P. REEDER.

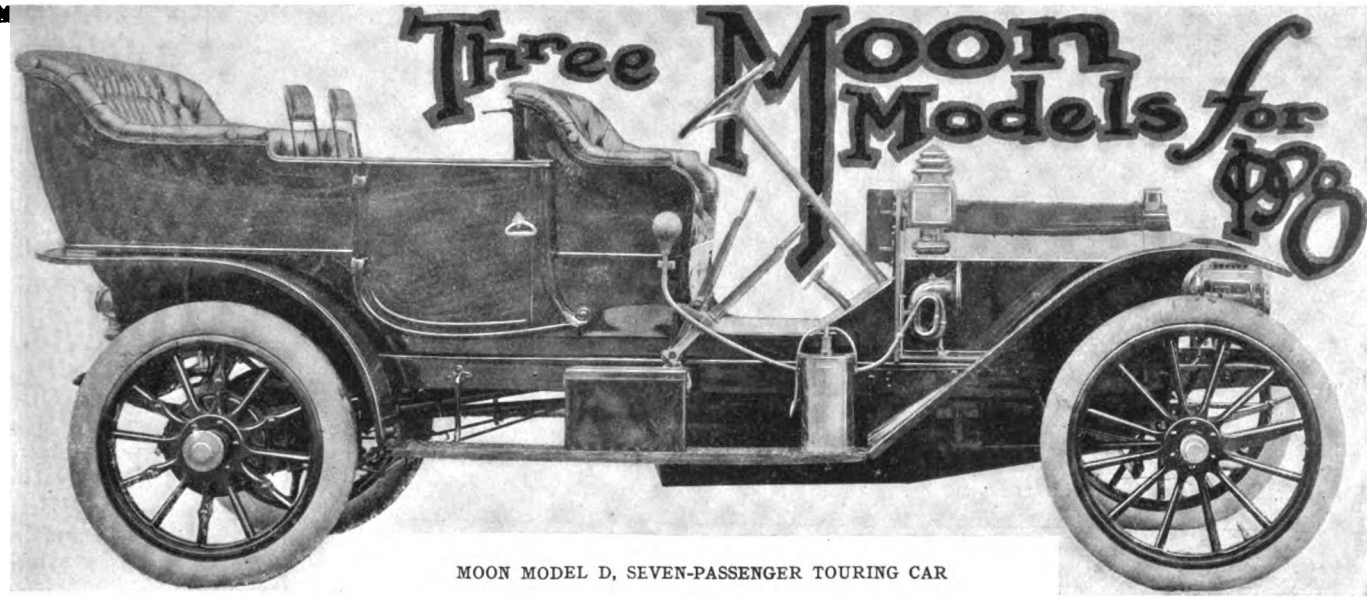

MOON MODEL D, SEVEN-PASSENGER TOURING CAR

**M**ORE than the usual interest centers on the Moon cars for the coming season, as, in addition to the output of the factory which will be marketed under this title, they will also be sold in the East under the name of Hol-Tan by the Hol-Tan Company, which formerly handled foreign cars exclusively. As has come to be very general practice with American manufacturers within the past few years, the builder, the Moon Motor Car Company, of St. Louis, will concentrate its attention on the production of a single, standard type of chassis, which, however, will be marketed as three distinct models, namely, a roadster, a five-passenger touring car, and a seven-passenger touring car. L. P. Mooers, the designer of the car, has been identified with the building of automobiles in this country for such a length of time, that his name in connection with a car is a sufficient guarantee of its close adherence to well-recognized engineering principles, as well as the incorporation of a number of special ideas of construction gleaned in a number of years' experience.

Foreseeing that the bulk of the present demand is rapidly leaning more and more strongly toward the moderate powered car, and that the ultimate demand will be almost entirely for a vehicle of this type, he has made the motor of a corresponding size, the bore and stroke measuring 4 1-2 by 4 1-2 inches, giving a maximum output of 38 to 40 horsepower at 1,200 r. p. m. on a brake test, thus permitting the car to be advertised as a 35-horsepower machine in full confidence that it will easily exceed its nominal rating whenever called upon to do so. In design the motor differs radically from the standard type in that a superimposed camshaft is employed and is driven from the crankshaft by a vertical spindle and bevel gearing placed at the forward end of the motor, as will be apparent upon reference to the illustration of this essential. A beam-axis rod is placed below the camshaft, on which the double-end, bell-crank beams rock, each beam working the two valves of the cylinder beneath it by means of an integral bell-crank fork, carrying a roller which comes in contact with the cam. The top of the camshaft turns toward the bell-crank roller, thus pushing

instead of pulling. The valve stems are slightly staggered, thus bringing the valves themselves inside a compression chamber but slightly larger than the bore of the cylinder. The valves are placed in cages and the tapered inner ends of the latter are ground into their seats in the cylinder heads. The bell-crank roller is held against the cam face by a coiled spring, hooked into the beam. This construction makes both valve cages the same,

requires but one cam for each cylinder and but one camshaft, though still retaining the much-desired opposite disposition of the valves. It also permits of liberal water spaces, so disposed as to insure effective valve cooling. Circulation is taken care of by a gear-driven centrifugal pump, while the essential of oiling is provided for by a mechanical force-feed type of oiler, having eight leads to the main bearings and other important points so that all the latter are kept directly supplied with oil, this being supplemented by splash in the crankcase. The latter is of aluminum, in two parts, the lower being but an oil pan, all bearings being attached to the upper half, thus making inspection and adjustments easy. Ignition is of the high-tension order and for running service a self-contained unit in the shape of a Simms-Bosch magneto is provided. For starting, and as a reserve, a standard four-unit coil and low-tension timer system, taking current from a set of accumulators, is installed. The mechanical oiler is driven from the overhead camshaft by means of a round leather belt.

The first step in the transmission of the power consists of a multiple ring type of clutch. It comprises 53 rings, or disks, all being of the same material, steel.

Twenty-six of these are held by tongues on the inside, or female member of the clutch, while the remaining 27 are held outside by grooves, in the male member. These rings are very thin, averaging but little more than 1-32 inch in thickness, thus making the complete clutch very compact. The large number of rings makes the clutch drive very well when in slipping engagement, this also giving it a soft action and preventing any jerky movement in starting. One universal is placed between the clutch and the

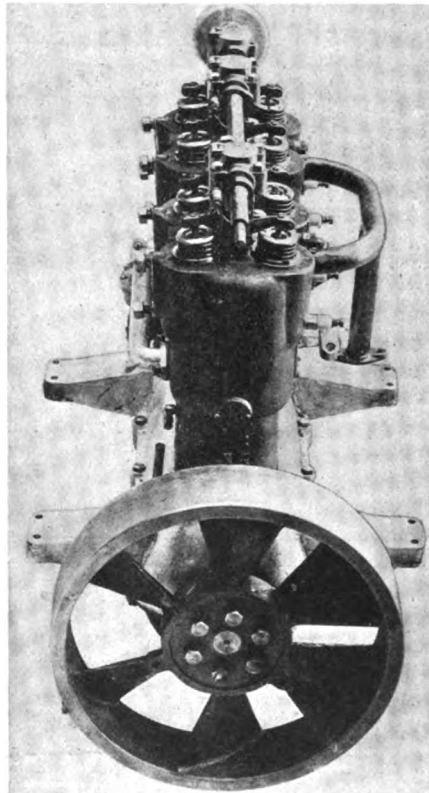

VIEW OF SUPERIMPOSED CAMSHAFT.

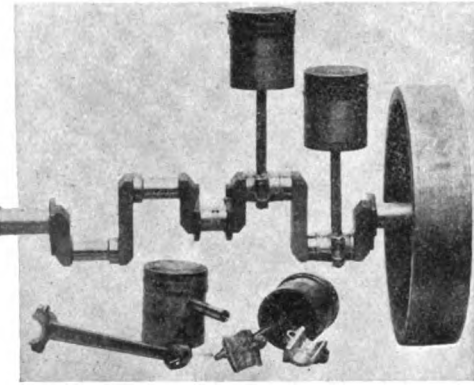

SOME ESSENTIALS OF THE MOTOR.

which squared revoluble locks are placed on two trunnions, set at an angle of 180 degrees, and which slide on the outer member. They are protected by flexible leather casings.

The gear-set housing consists of two aluminum members, joined in the plane of the line and countershafts, which are supported on bearings of Parsons' white bronze, the housing being designed particularly with a view to compactness in view of the

line shaft of the gear-set, while universals are also used at each end of the propeller shaft, all being of the same type, with the exception of the first, which is made with its shell split so as to facilitate assembly. These joints are of the well-known trunnion type in

are inserted and brazed, extending through to the wheel hubs at their outer extremities, the driving axle being of the full floating type. A spur differential is employed, the pinions running on four-point ball bearings, while the rear wheels are run on three-point ball bearings. Brakes are of the external contracting and internal expanding type, the friction surface being lined with camel's hair belting, the outer bands being so applied as to make the brakes equally effective in either direction. The brake equalizers are steel tubes suspended by links jointed transversely at the top and longitudinally at the bottom. The brake rods are attached at the center of these long, tubular steel equalizers, thus perfectly balancing the resistance of one brake against the other and making a simple arrangement not likely to become deranged.

Full elliptic springs are employed on the rear and semi-elliptics in the front, the latter being jointed in front and linked at the rear, while the rear springs are revolubly mounted on the rear axle saddles, or perches, and are similarly connected to trunnion brackets attached to the side frames at the top. In order to provide ample room for spring action at the rear, the ends of the side members of the pressed steel frame are raised 3 1-2 inches. The steering gear is of the screw and nut type, consisting of two threads, or screws, a right and left-hand one, on the steering column, with integral nuts and pushers communicating the

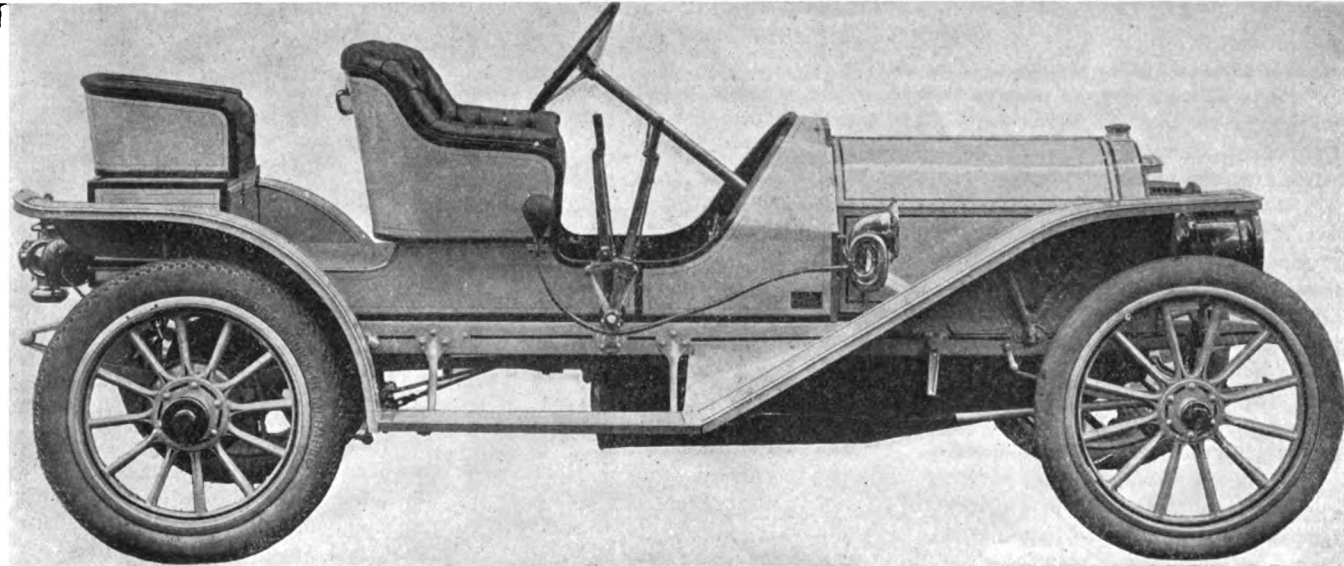

ATTRACTIVE LINES OF THE MOON ROADSTER AS SEEN FROM THE RIGHT HAND SIDE OF THE CAR.

size of the pinions employed. The countershaft, or lay shaft, is placed to the left of the line shaft and the arrangement of the pinions gives four forward speeds and reverse, working on the selective type of operation.

As the design of the car has been very thoroughly tried out in the past two years or more that it has been on the market, scarcely any changes were found necessary in the chassis for the coming season, the few that were made consisting of that refinement of detail suggested by experience with a large number of cars. There are numerous points about the construction which, unimportant in themselves, when taken as a whole, are strongly indicative of the painstaking attention that has been devoted to the evolution of the entire design. For instance, both front and rear wheels are dished, the knuckle pins being slightly inclined in the case of the forward pair, thus bringing the top ends of the pins nearer together than at the bottom and making the wheel spokes stand vertically, from the road surface to the hub. In the same manner the rear axle is given a certain amount of camber, to achieve the same end in the case of the rear wheels.

The front axle is one-piece steel drop forging of I-beam section, while the rear axle load-carrying member consists of a steel casting in the shape of the bevel-gear housing, into which steel tubes

motion set up by turning the wheel to the double-ended bell-crank member of the steering arm. The cross-connecting rod of the steering gear is placed behind the front axle in a protected position. Control is of the usual type, both spark and throttle levers being situated on a stationary segment above the steering wheel. The mahogany "front board" carries the eight sight-feeds of the oiler, but is otherwise practically unencumbered.

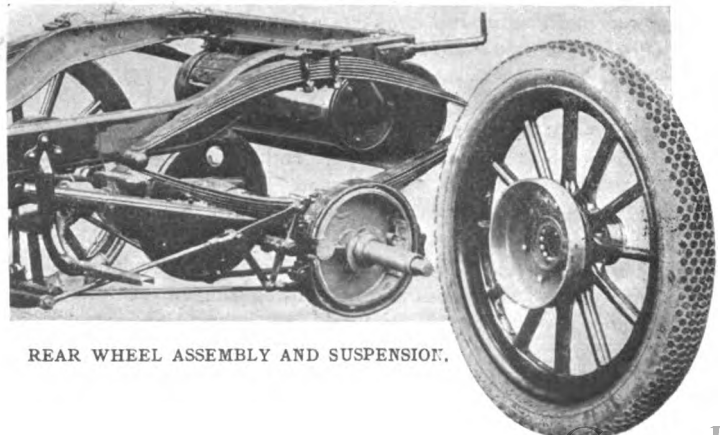

REAR WHEEL ASSEMBLY AND SUSPENSION.

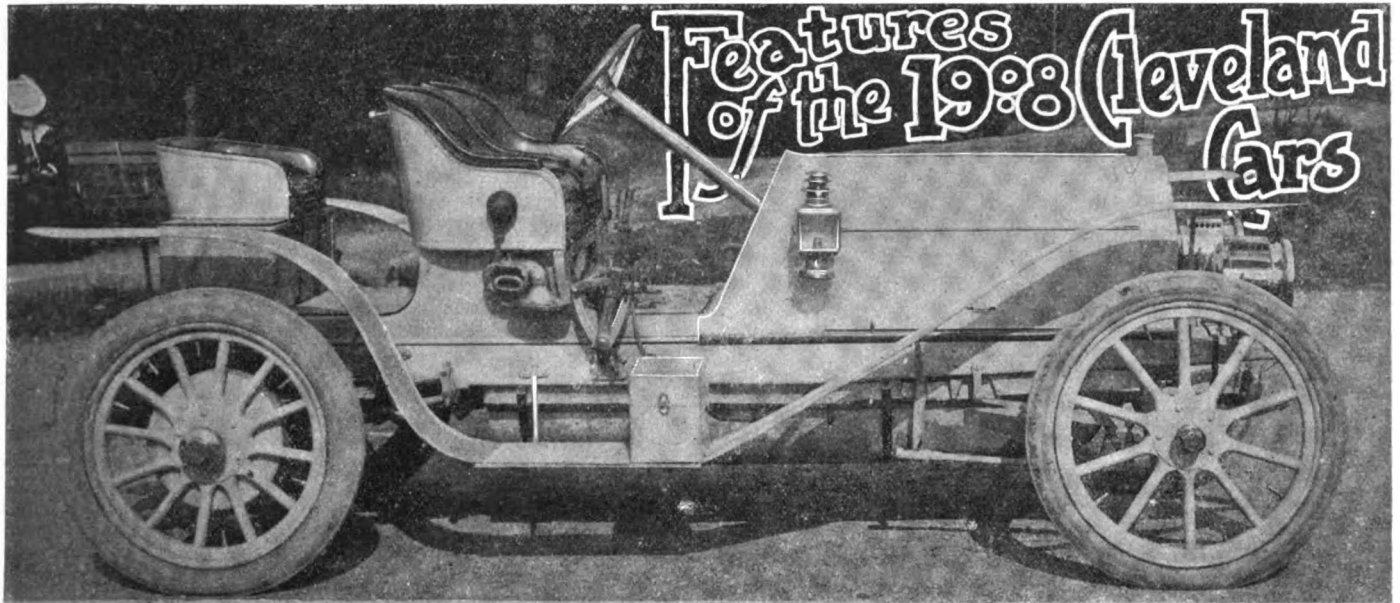

NUMEROUS special new features mark the Cleveland car for 1908 from its predecessor, prominent among them being the adoption of a multiple disk clutch, which, in accordance with the highest standards of practice in this respect, is housed together with the gear-set, thus making a unit of this important essential. This clutch consists of 52 steel plates, 1-16 inch thick, made of special high-carbon steel. They are stamped into a conoidal form, differing from a true cone in that the surface is slightly curved. This arrangement causes the plates to engage very gradually and when released, the spring of the material, aided by that of the curved portion, causes the plates to separate, regardless of the character of the lubricant employed, it being the claim of the makers, the Cleveland Motor Car Company, 1659 Broadway, New York City, that this clutch will disengage as readily when immersed in heavy oil or grease as when light oil is used. In actual service the same lubricant as is employed in the gear-set, consisting of one-half heavy oil and half grease, is employed for the clutch as well. The rockers for disengaging the clutch are provided with steel rollers at their ends, engagement of the clutch proper being effected by a heavy helical spring, of approximately 300 pounds tension, the latter being adjustable to suit varying conditions. This clutch is entirely self-contained and gives no end thrust except when disengaged, when the thrust of the spring is taken on F. & S. annular ball bearings of liberal size. The gear-set provides four forward speeds and the usual *marche arriere*, working on the selective principle of gear-changing, the lever being operated in an H-shaped sector. Though standard in this respect, a distinction is to be found in the fact that the direct drive is in the third speed, the fourth being an accelerated speed. This

arrangement permits of almost constant use of the direct drive with a consequent saving of the gears, and also provides an extra high speed on occasion, when the propeller shaft can be made to run faster than the engine. Annular ball bearings are used throughout the gear-set, and the shafts are milled, forming four integral splines for the sliding members. Immediately behind the gear case is placed a 14-inch wheel provided with heavy ratchet teeth and a plunger pawl, this device constituting a convenient substitute for the sprag. The base of the pawl is an accurate sliding fit in a small cylinder, thus forming a dash pot. It is operated by a small button located on the footboard, but a slight pressure of the heel being sufficient to cause it to act.

A bevel type of differential is employed, using liberal size gears of five pitch, all being supported on annular ball bearings. An adjustment is provided so that the bevel pinion and its shaft can be moved slightly in a longitudinal direction, thus bringing the teeth into, or taking them out of mesh with the large driving bevel. In order to provide for this, the annular bearing in front of the bevel pinion is held against a collar on the bevel pinion shaft on one side, and a nut on this shaft at the other side, so

that if this bearing is moved in either direction the bevel pinion and shaft must move with it. On the exterior of the annular ball race are threads into which, or upon which, an outside band or collar is screwed. This collar cannot move backward or forward, as it fits into grooves in the rear-axle housing, so that by simply turning it on its threads the bearing is forced in either direction as desired. This collar is prevented from rotating and is retained rigidly in position by means of a tight-fitting yoke which presses upon it when bolted in position. It also bears on the outside annular ball-race,

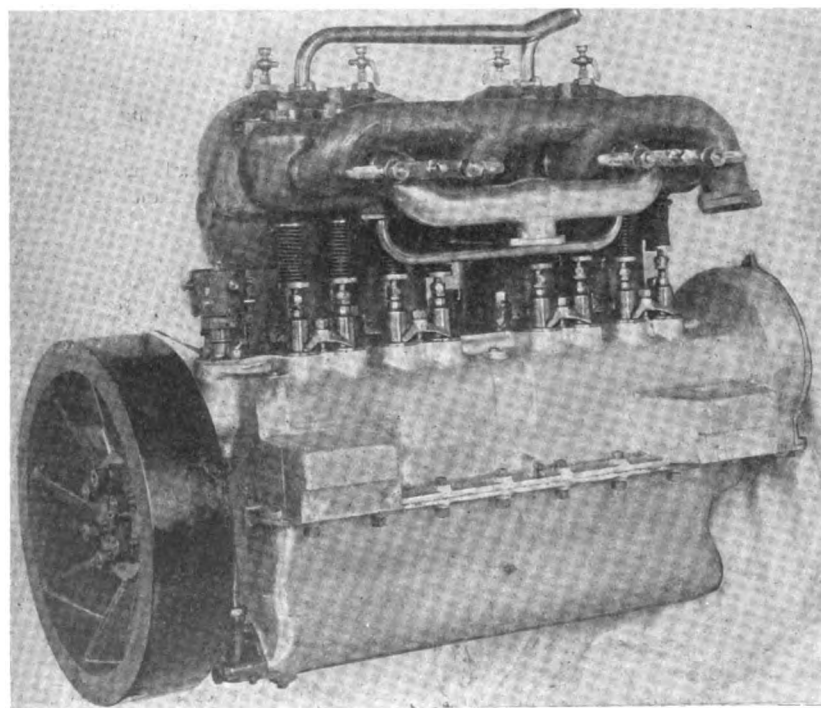

VIEW OF WORKING SIDE OF THE NEW CLEVELAND MOTOR FOR 1908.



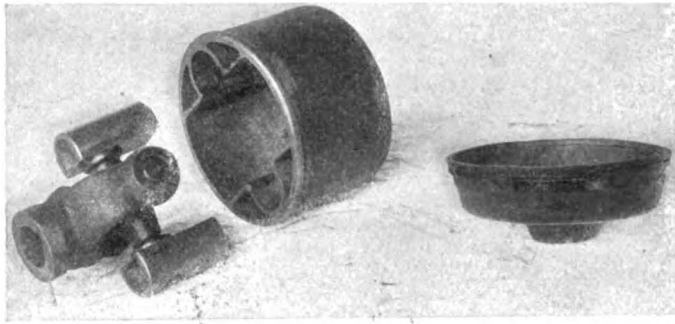

DETAILS OF ONE OF THE UNIVERSAL JOINTS.

thus clamping the combination rigidly in position, adjustment being made by merely loosening the yoke and turning the collar.

The rear axle is of the floating type, driving the wheels by means of lug clutches at the ends. The supporting housing or axle is well braced by means of a 5-8-inch truss rod, this being its dimension at the smallest section, increasing considerably at the portions where it is threaded for the turnbuckles—in fact, the liberal size of the parts used throughout the construction of the car is one of the distinctive features of the 1908 Cleveland. An I-beam torsion rod is employed and radius rods are also fitted, their rear ends being revolvably mounted upon split bronze bushings, which are clamped around the steel rear axle housing, thus concentrating all the wear on the bushings. The latter also serve for the swivel mounting of the rear spring seats. The front axle is a one-piece I-beam drop-forging, the steering knuckle pivots being mounted on ball bearings while the cross rod of the steering gear is placed behind the axle in a protected position. The steering gear is of the standard screw and nut type.

Brakes are both of the internal expanding type, in contrast with general practice in this respect, and differ further from the latter by the provision of a special double drum, as shown by the reproduction of a photograph in one of the accompanying illustrations. This provision should go far toward increasing the efficiency of the brakes by effectually preventing any tendency to overheating on long steep grades, where it is necessary to alternate from one to the other in order to hold the car, or where both

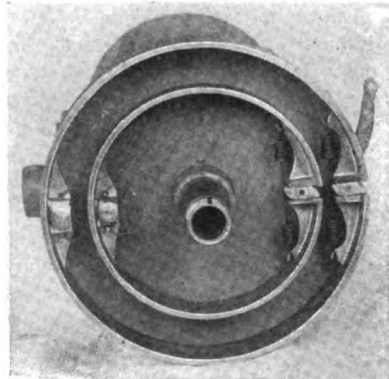

SHOWING THE SEPARATE BRAKE DRUMS.

are used together. The outer one of the two brakes is 16 inches in diameter by 3 inches face, thus providing an unusually liberal amount of friction surface. Both are of the metal-to-metal type, the drums being of pressed-steel construction, while the bands are manganese bronze, both being operated by a cam in the usual manner. A single-tree type of equalizer is employed on the foot brake, which is the outside band, the other, or emergency brake, being operated by the usual side hand lever. Pressed steel is also used in the construction of the muffler, which is provided with a cut-out operated by a foot button. At every point on the car where there is any movement grease cups are provided, while the brake rods and spring eyes are equipped with spring oilers. The muffler rod, sprag operating rod and brake rods are all so arranged that the pull on them is direct.

The motor is of the standard, four-cylinder, four-cycle, water-cooled type, the cylinders being cast in pairs. Two independent

systems of ignition are employed, both being of the high-tension type. A high-tension magneto is employed on the running side, while a single vibrating coil and distributor system constitute the reserve, current being supplied by a set of accumulators. Each system is independent throughout, as two sets of spark plugs are used, both being placed over the valves. All the accessories are driven from a special shaft, the rear end of which operates the pump and magneto, while a belt from a pulley at its other extremity drives the bronze-hub aluminum fan directly back of the radiator. A Schebler carbureter takes care of the essential of gas supply, being provided with gasoline from a 22-gallon copper tank placed under the seat so as to feed by gravity, a large strainer being interposed between the tank and carbureter. The tank filling hole is made six inches in diameter, so as not alone to facilitate replenishing it, but also to make possible its thorough cleaning out, the cap being held on by a removable yoke, instead of the usual screw fastening.

A special feature of the cardan shaft drive is the simple type of universal joint employed. One of these is illustrated in pieces in order to show the small number of parts forming its essentials, as well as their simplicity. These joints are inclosed in dust and oil-tight housings, the forward part of the housing having a spherical rear end over

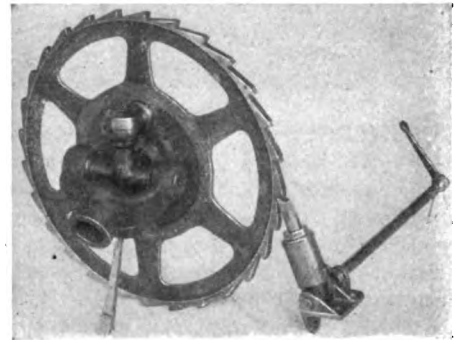

DETAILS OF THE INGENIOUS SPRAG.

which the rear portion of the case fits, the latter being provided with an internal annular recess containing a strip of felt. This felt comes in contact with the spherical portion of the forward part of the case, thus making a dust-tight but flexible joint. The rear universal joint is so arranged that the driving effort is transmitted by the outer ends of the arms fitted with bronze shoes which are free to slide longitudinally in suitably shaped semi-circular grooves of considerable length in the outside casing, which is fixed to the bevel pinion shaft. The casing is of steel and has a long hub taper keyed to the integral bevel pinion shaft, the shaft pinion being supported both front and back by F. & S. annular ball bearings of liberal dimensions.

Another special feature of the car is the use of an aluminum steering wheel of large diameter, the arms being of aluminum, channel section and having a continuous, integral rim. The control levers operate on an aluminum sector, each lever being provided with a small hard rubber thumb button, automatically locking it when the hand is removed.

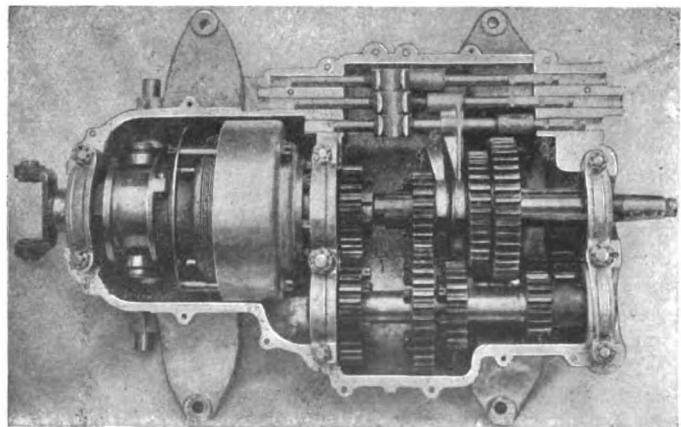

THE SPECIAL CONOIDAL CLUTCH AND GEAR SET



COMPILERS E. R. MIXER AND EDITOR ROBERT BRUCE IN THE OFFICIAL AUTOMOBILE BLUE BOOK CAR, WHICH IS A THOMAS FLYER.

## TWENTY THOUSAND MILES THUS FAR BY THE BLUE BOOK CAR

THE automobile tourist who travels by "The Official A. A. A. Automobile Blue Book" during 1908 will find that the publishers have not been idle the past few months in revising many sections and writing up new territory, long neglected, that affords every temptation to those who enjoy good roads, whether they are traveling through the mountains or along the seashore.

In the last five months the compilers have prepared over 20,000 miles of route directions from data collected by personally covering every mile with the Blue Book car—which is a Thomas Flyer runabout—and taking the exact distances to the tenth of a mile for every turn, fork, or landmark along the road. The machine has been equipped with two reliable odometers, and there

should be no question in the tourist's mind as to how far he must travel before the next turn is made. He has the running distances for all points along the road where any information is needed.

A good share of time and work has been spent in the thinly settled sections—sections noted more for their beautiful scenery and climate than for population—where in encountering forks and turns definite information is always welcome and indispensable. Nearly the entire coast of New England has been skirted; the White mountains have been handled in a most careful way, covering every desirable road to the Canadian line; nearly all of the necessary routes in Massachusetts will be well described, even to the farthest point on Cape Cod—a section lately discovered to contain the finest automobile roads in the country.

Every mile in New Jersey territory, from the mountains in the north to Cape May in the south, will have new and exact running directions; the eastern edge of Pennsylvania has been

worked out, and many of the exits and entrances to Philadelphia carefully taken care of. The Hudson river routes will look different to the stranger who has ventured that way and always finds trouble in getting through on the right road. Everything has been thoroughly explored in that direction.

Long Island has been covered from one end to the other and from the north shore to the south shore on all important cross-roads. It will be taken care of in the coming edition in a far more detailed way than has ever been accomplished at any previous time.

Most of this data has been made during severe weather, but with constant plugging the task has been accomplished and the efforts will be well appreciated by those desiring good, reliable directions for 1908. The endorsements of high-class hotel and garage accommodations have been carried forward in the same careful manner that the Blue Book contained during 1907—a feature well appreciated by the tourist traveling in strange territory.

## ANOTHER OWNER WHOSE UPKEEP HAS BEEN ECONOMICAL

Editor THE AUTOMOBILE:

I notice in your issue of December 12, 1907, the detailed car expense account of B. N. C., of San Francisco, and it appeared so excessive that it impelled me to look up my own account, particularly because from the description of the car I suspect that it is of the same make as my own.

I received my 1907 model car about the middle of December, 1906, but on account of adjustments required before it was acceptable, and continuous rainy weather and mud, it was nearly two months before it had much use. It has been used on the eastern side of San Francisco bay and to the south, where the roads are good, no trip exceeding 125 miles per day, and a total to date of between 3,000 and 4,000 miles only.

I have stabled the car at home, and have looked after such minor repairs and adjustments as time and inclination would permit. Such work as putting on a trunk rack, muffler cut out and adjustments requiring considerable time in dismounting and reassembling has been sent to the shop.

My original tires, 32x4, are still in use, and the outer casings are not broken, showing only such cuts and wear as might be expected with careful use on fairly good roads. I have bought two extra inner tubes as a precaution. After following the advice to use plenty of oil, and wiping most of

it off the outside of the engine and connected parts, I settled down to my previous practice with a former runabout, and have found that the machine will do upwards of 300 miles per gallon, runs just as well and is much cleaner.

Gasoline consumption is not as satisfactory. I do not think that the carbureter is well adjusted in that particular, but the car performs well, and I imagine that any adjustment which would increase its mileage per gallon would be liable to decrease its efficiency.

My expense account to date is as follows:

Shop repairs, new additions and adjustments.....	\$79.75
Extras added to original equipment.....	45.45
Gasoline .....	91.40
Oil .....	10.00
Lights, carbide and coal oil.....	10.00
Two inner tire tubes.....	18.00
Repair of punctured outer tire case.....	6.50
	<hr/>
	\$261.10
Cr.: Two inner tubes of former car, at \$4.50.....	\$9.00
36 lbs. worn out casings of same, at \$0.08.....	2.88
	<hr/>
	\$11.88
	<hr/>
Total expense.....	\$249.22
SAN FRANCISCO, CAL.	G. H. S.

## ECONOMICAL MILEAGE BY TWO OWNERS.

More facts are daily coming to light of the economical upkeep of cars by enthusiastic owners. Some of these records are sent to manufacturers by customers, and Thomas B. Jeffery & Company, Kenosha, Wis., announce the receipt of two letters which show the possibilities of the situation where the average owner of an automobile is concerned. And this is just the point, for these expense accounts have not been the result of the expert superintendence of the trained factory man, but those of the autoist who, in many cases, had but a faint notion of what was under the bonnet of a car before he actually became the owner of one.

One from Walter A. Merrill, of Binghamton, N. Y., states that he has run his Rambler car 4,000 miles during the past year with a total repair bill, outside of a few punctures, of \$9.40. During the season he has made 273 trips and has never required assistance on the road. His letter states that he calls that "real economy."

J. A. Baughman, of Barberton, O., states that he owns a 1906 Rambler, Model 14, which he has run up to date 8,500 miles at a total repair expense of \$4.

## AUTOWAY IN WEST FOR SPEEDING.

WAUKEGAN, ILL., Jan. 9.—Automobile enthusiasts are much concerned in a persistent rumor that there is a project on foot to locate a costly speedway between this town and the Wisconsin State line. The alleged purpose is to hold auto events of a racing and speeding nature over a three-mile track built of concrete.

It is claimed that this project has been mooted since last October and the apparent secrecy with which it has been carried on was and is for the purpose of securing options on land at fair prices. It is now claimed that options covering over 500 acres have been secured, and it is expected that the scheme will be outlined at an early day.

The land on which the options have been taken lies in the path, as it were, of the famous Sheridan drive that ultimately will connect Chicago with Milwaukee. The driveway lays along the shore of Lake Michigan and now connects all of the North shore suburbs almost to Waukegan. It is rumored here that Eastern capital is back of the speedway project, but the names of the backers have not yet been made public.

## THIRD ANNUAL MEETING OF THE AUTO ENGINEERS

MORE than the usual amount of interest attached to the holding of the third annual meeting of the Society of Automobile Engineers, which took place during the afternoon and evening of Friday last, January 3, as the need for an organization of this character in the automobile field has been most strikingly manifested by its exceedingly rapid growth during the two years of its existence, which, from the outset, has been under disadvantageous conditions of a sufficiently serious nature to cause the immediate dissolution of any association in which the members were not genuinely interested and eager to come to its support. Probably the most convincing evidence of the demand there is for such an organization is to be found in the report of the membership committee, showing that the list of members has been increased by more than 50 per cent. during the past twelve-month, despite the fact that no organized effort has been carried out either to secure publicity or to enlist the interest of the technically skilled branch of the automobile fraternity as a whole.

### New Constitution and By-laws Proposed.

The afternoon session of the meeting was opened by President A. L. Riker, H. M. Swetland being appointed secretary *pro tem.* in the absence of E. T. Birdsall, secretary-treasurer. The minutes of the last meeting, which was held at Buffalo and Niagara Falls on July 30 and 31 last, and which included an inspection of the plants of the George N. Pierce Company, and the E. R. Thomas Company, having been read, the reports of the various standing committees were in order. Henry Hess, chairman of the committee appointed by President Riker at the summer meeting to revise the constitution of the society, reported that after carefully investigating the constitution and by-laws of several kindred organizations, his committee had come to the conclusion that the constitution of the American Society of Mechanical Engineers was the most carefully worked out, and was based on the results of a long existence and gradual expansion from small beginnings. "As it is hoped that this Society will also maintain as healthy a growth as its members may so far congratulate themselves upon," continued Mr. Hess, "your committee thought it could not do better than to follow very closely the Constitution, By-laws and Rules of the American Society of Mechanical Engineers, with, of course, such alterations and additions as the somewhat different objects of your Society rendered advisable."

Mr. Hess accompanied his report with a carefully prepared draft of the proposed constitution and by-laws founded on those of the American Society of Mechanical Engineers, with such alterations as the changed conditions and aims of the Society of Automobile Engineers required, and a resolution was passed instructing the secretary to have copies of the same printed and forwarded to the members for their approval or disapproval.

President Riker then called for the report of the committee headed by Mr. Schaeffers, which was appointed at the summer meeting, to come to an agreement with the Automobil Technische Gesellschaft, Berlin, for a mutual interchange of memberships, but in the absence of Mr. Schaeffers and the statement of his committee that the negotiations had not been concluded as yet, further action in the matter was deferred till the next meeting. Reading of the report of the treasurer was also deferred owing to the unavoidable absence of Mr. Birdsall. Chairman H. F. Donaldson of the Publication Committee reported on the activities of his committee during the past six months, which chiefly concerned the securing and publication of papers to be read at the regular meetings, a duty which, under the new constitution, will be devolved upon two separate committees. He was followed by H. M. Swetland, chairman of the Entertainment Committee. At the last meeting it was decided to make the

membership committee a committee of the whole, so that no formal report was prepared, but the successful outcome of the plan was apparent in the fact that during the past year the membership of the society has been increased by over 50 per cent.

The annual election was then held, Thomas J. Fay, New York, being unanimously elected president; E. T. Birdsall, Rochester, N. Y., second vice-president, succeeding John T. Wilkinson, and Henry Hess, Philadelphia, succeeding Mr. Birdsall, formerly secretary-treasurer, the constitution of the society prohibiting the holding of the same office for more than one term. F. J. Newman, Chicago, and Russell Huff, Detroit, were elected managers for three years, vice H. Vanderbeek and A. H. Whiting, whose terms expired. The other officers of the Society are Henry Ford, Detroit, first vice-president, and L. T. Gibbs, H. M. Swetland, H. P. Maxim and W. H. Alden, managers. President Fay appointed Charles B. Hayward as secretary, succeeding E. T. Birdsall.

Following the business meeting, papers on various subjects were read, including "Automobile Hub Bearings," by Henry Hess; "Some notes on Self-Aligning Taper Bearings," by H. W. Alden; "Nature Hard Gears," by Thos. J. Fay, and "Usually Unobserved Refinements of Automobile Construction," by J. Magee Ellsworth and Thos. J. Fay. Most of the papers were accompanied by numerous drawings illustrating the points brought out by their authors, Mr. Hess also accompanying his by sample bearings taken from automobile rear wheel hubs, showing the destructive effect of rust and grit on this important part of the car. Each one of the papers brought forth considerable discussion and numerous interesting points were raised.

Upon the conclusion of the discussion following the reading of the last paper, the afternoon session adjourned to reconvene at the annual dinner held at the New Grand in the evening. This was in turn followed by a second session of the business meeting, during the course of which numerous important matters came for discussion.

### Next Meeting at Boston in March.

It being the consensus of opinion of the members present that the society should meet more frequently, it was decided that in future quarterly meetings should be held, and the importance of the Boston show being realized, a resolution to the effect that the next quarterly date be anticipated somewhat in order to bring the meeting during the course of that show, was unanimously adopted. The point was raised as to whether formal papers should be prepared and read at these quarterly sessions, or whether topics for discussion should simply be suggested in advance, and discussed informally at the meeting.

It was decided that papers should be prepared, and a number of the members, well known in the automobile world, volunteered to write on various subjects, among those suggested being "Materials and Design of Automobile Crankshafts"; "Die-forgings for Automobile Work"; "The use of Alternating Current Rectifiers"; "Improvement of the Two-cycle Motor"; "Drawing Room Equipment for Automobile Factories," and others of an equally interesting nature, many of which are to be prepared in time for reading at the Boston meeting, the secretary being instructed to print and distribute these papers in advance of the date.

The following were present: A. L. Riker, Henry Hess, H. F. Donaldson, J. M. Magee, Joseph Tracy, M. C. Krarup, H. M. Swetland, J. A. Crowley, Thos. J. Fay, H. L. Towle, W. P. Kennedy, A. H. Whiting, H. H. Brown, H. P. Moorrees, J. A. Anglada, R. W. Funk, R. Newton, Thos. Zimmerman, P. M. Heldt, A. C. Bergman, Wm. Hasselkus, A. H. Ehle, A. L. McMurtry, B. D. Gray, H. M. Crane, E. F. Schnuck, M. R. Hutchinson, and C. B. Hayward.





Vol. XVIII Thursday, January 9, 1908 No. 2

THE CLASS JOURNAL COMPANY

Flatiron Building, Madison Square New York City

H. M. SWETLAND, President

EDITORIAL DEPARTMENT

A. G. BATCHELDER, Managing Editor R. F. KELSEY, Associate Editor C. B. HAYWARD, Engineering Editor W. F. BRADLEY

BUSINESS DEPARTMENT:

A. B. SWETLAND, Business Manager LOUIS R. SMITH FRANK E. BARNETT W. I. RALPH, 1035 Old South Building, Boston, Mass. C. H. GURNETT, H. E. WESTERDALE, 836 Monadnock Block, Chicago, Ill.

Cable Address - - - - - Autoland, New York Long Distance Telephone - - - - - 300 Gramercy, New York

SUBSCRIPTION RATES:

United States and Mexico - - - - - One Year, \$3.00 Other Countries in Postal Union, including Canada - - - - - One Year, 5.00 To Subscribers—Do not send money by ordinary mail. Post-Office or Express Money Order, or Register your letter. Remit by Draft.

FOREIGN SUBSCRIPTION AGENTS:

ENGLAND:—Hilffe & Sons, Limited, 20 Tudor Street, London, E. C. FRANCE:—Boyveau & Chevillet, 22 Rue de la Banque, Paris. GERMANY:—A. Seydel Mohrenstrasse 9, Berlin.

Copyright, 1907, by The Class Journal Company. Entered at New York, N. Y., as second-class matter. The Automobile is a consolidation of The Automobile (monthly) and the Motor Review (weekly), May, 1902, Dealer and Repairman (monthly), October, 1903, and the Automobile Magazine (monthly), July, 1907.

Table with 2 columns: Year and Copies printed. Rows for 1905 (730,000), 1906 (791,000), and 1907 (888,900).

A Conflict of State and Municipal Legislation.

In the matter of legislation, New York State has long been looked upon as one of the most progressive communities in the Union, and its lead in dealing with the legal side of the many problems of commercial and domestic relations has been followed by a large number of the other States. The same thing is true where automobile legislation is concerned, but the recent decision of the Court of Appeals, in the case brought to test New York City's much discussed ordinance, would appear to place it in quite a different light. Under the Motor Vehicle law of New York, local ordinances are prohibited except where they impose a uniform speed limit of ten miles an hour on all vehicular traffic, and signs are posted to that effect.

Despite the fact that the law has not been complied with in the latter respect, the court of last resort has held that the ordinance is valid, but to support this contention it has been necessary to make the State law begin where the city ordinance leaves off. In other words, the autoist who exceeds the archaic eight-miles-an-hour municipal restriction, but in doing so does not surpass the ten-miles-an-hour limit of the State law, is amenable under the former and the maximum penalty incurred cannot exceed \$10. If he break both by driving more than ten miles an hour, then the State law becomes operative.

Despite the fact that no vehicle capable of exceeding it ever keeps within the absurd limit nominally imposed by the city authorities, something which practically renders the present municipal ordinance void despite the court's decision to the con-

trary, such a situation can only lead to confusion and dissatisfaction. While the recognition of New York's ordinance, without the condition attached to it by the court's decision, might be desirable from several points of view, if its upholding were to precipitate a flood of local ordinances throughout the State, the privileges gained under it would be dearly bought. The endless annoyances arising out of the pernicious activity of village councilmen brought about the general prohibition of local ordinances which is now a feature of most State legislation. Of what value will uniform State laws be if they are such only in name?



Singular Phase of the Desire for Speed.

With the unprecedented capacity of the automobile for speed, and the fact that it represents the culmination of human invention to satisfy the innate passion of the average individual to be able to travel quickly and at the same time control his own mode of getting over the ground, it is not strange that the ways in which the latter has been manifested have been numerous. Not the least strange of these is the desire of the autoist whose circumstances limit him to the possession of a low-powered car to make it a vehicle capable of traveling at a far higher rate of speed than its creator ever intended it for.

After having enjoyed the use of such a vehicle for a season or more, its efficiency is not what it was originally and its owner's desire for greater speed and hill-climbing power has grown in inverse ratio to the car's falling off. More power and more speed is his demand, and to satisfy it the expedients of increasing the compression of the motor and of raising the gear ratio of the car seem to be those most frequently thought of. Of the two, judging from the number of letters received from correspondents, the latter appears to be the more popular, and the plans for increasing the speed of the car do not, in the majority of instances, include any provision for making a corresponding increase in its power. It should be borne in mind that speed is but one of the manifestations of power and its attainment involves other factors than that of the relative number of revolutions of the engine and road wheels, and the fact that every increase in speed shortens the life of every part of the car should not be overlooked. In most cases restoring the car to its original degree of efficiency will suffice to accomplish all that can be safely recommended in this direction, and the practice of tinkering a 10-horsepower runabout in an attempt to make it the equal of a 25-horsepower car is to be deprecated.



Brake Improvement on the Cars for 1908.

While it is with pardonable pride that the American manufacturer regards himself and his product as having progressed beyond the influence of foreign standards, where betterment is concerned, the unprejudiced observer cannot but admit that the builder of European cars pays considerably more attention to the highly important essential of brakes than does his competitor in this country. It is a practice that the foreign builder has consistently adhered to for several years past, and while it may be considered that, in some instances, the factor of safety provided for has reached extremes, exceeding the requirements in this direction is more commendable than falling short of them.

American makers have practically abandoned the transmission brake where the 1908 cars are concerned, and inspection of the latter also bring to light the fact that more attention has been paid to the matter of the dimensions of the brake bands and drums, now almost universally to be found on the driving wheels, where they belong. Separating the friction surfaces against which the two brakes bear by making the drum double is also a most commendable feature, as in removing the heating influence of one from the other, this being a disadvantage where an external contracting and an internal expanding brake bear against opposite faces of the periphery of the same drum, both are made more efficient and at the same time entirely independent.

## JANUARY DATE FOR NEXT A. L. A. M. SHOW IN GARDEN

**M**OST important of the decisions arrived at by the board of managers of the Association of Licensed Automobile Manufacturers at its meeting at the association's offices, 7 East Forty-second street, New York City, Tuesday, January 7, was the resolution adopted setting the time for the next annual show for January, 1909, in Madison Square Garden. This is practically a return to original show dates, and is an indication that the November-December dates of the 1907 show were not as advantageous as had been expected. Colonel George Pope, chairman of the show committee, in his report stated that the recent show had been the most successful of any yet held, but advocated a return to the January date as more suitable to recognized business conditions. Optimistic forecasts regarding business prospects for next season were made by several members of the Association.

Persistent rumors were current prior to and during the prolonged session of disensions within the association, and of an intention to reorganize. Prominent members emphatically deny these reports, and General Manager M. J. Budlong stated that the same progressive policy would be

maintained in the prosecution of infringers of the Selden patent, and that the general policy of the association would be carried out as in the past. The following members were present at the meeting:

J. S. Clarke, Autocar Company; W. E. Metzger, Cadillac Motor Car Company; H. S. Hart, Corbin Motor Company; H. S. Lloyd, Electric Vehicle Company; B. A. Becker, Elmore Manufacturing Company; H. H. Franklin, H. H. Franklin Manufacturing Company; C. H. Haynes, Haynes Automobile Company; E. R. Hewitt, Hewitt Motor Company; E. H. Cutler, Knox Automobile Company; S. T. Davis, Jr., Locomobile Company; H. Lozler, Lozler Motor Company; C. W. Matheson, Matheson Motor Car Company; V. M. Gunderson, Northern Motor Car Company; F. L. Smith, Olds Motor Works; H. B. Joy, Packard Motor Car Company; L. H. Kittredge, Peerless Motor Car Company; Charles Clifton, George N. Pierce Company; A. L. Pope, Pope Manufacturing Company; George Pope, Pope Motor Car Company; E. D. Shurmer, Royal Motor Car Company; G. E. Mitchell, Alden Sampson, second; R. H. Salmons, Selden Motor Company; E. McEwen, F. B. Stearns Company; C. C. Hildebrand, Stevens-Duryea Company; H. H. Eames, Studebaker Automobile Company; E. C. Morse, E. R. Thomas Motor Company; E. P. Chalfonte, Waltham Manufacturing Company, and T. Henderson, Winton Motor Carriage Company.

## MASSACHUSETTS MAY HAVE GRADUATED REGISTRATION

**B**OSTON, Jan. 6.—Governor Guild of Massachusetts apparently is not wholly satisfied with what the Legislature did last year in the way of putting the cost of the maintenance of the State roads upon the automobilists. In his inaugural address, delivered at the assembling of the Legislature for 1908, this week, he again devoted some space to a consideration of the question of automobiles and the roads and he again recommends that a system of graduated registration fees be put into force. The Governor also gets after the automobilists from outside the State, thousands of whom come here every year and use the improved roads without contributing anything for their repair or maintenance. That some legislation in the form of a measure for a graduated registration fee will be presented at this term of the Legislature there is little doubt, for members

of the Senate are still somewhat disgruntled at the defeat which they received at the hands of the House last year, when a deadlock was broken in the last days of the session by the Senate abandoning its bill for a graduated registration fee and permitting the House bill for a flat annual fee to pass.

Local owners of cars undoubtedly will oppose a graduated fee bill or any other change, because they believe that much harm is done by continually tinkering with the law, and that the measure passed last year should be given a more thorough trial before it is abandoned. They believe also that more inequalities would arise from the enforcement of a graduated fee than from the present flat fee system. Any proposition to put more burdens upon the tourist will be opposed by the many citizens interested in the lucrative summer resort business of this State.

## MOTORING MAYOR OF NEW YORK RECOMMENDS WISELY

**B**Y protesting against the exhaust cut-out, the use of sirens, smoky exhausts, and acetylene searchlights within the built-up portion of the city, Mayor McClellan of New York City has taken a step which will be approved by right-minded autoists.

It was in his annual message to the Board of Aldermen that the Mayor put forth his view on the control of automobilists while within the city. After pointing out that some provision should be made for licensing all sightseeing automobiles, which at present pay no fee whatever to the city, the Mayor protested against the use of the siren within the city limits on all automobiles other than those connected with the Fire Department. His other recommendations were that all automobiles should be equipped with adequate mufflers, which should never be cut out within the limits of the built-up portions of the city. That, ex-

cept for the first ten seconds after starting the engine, no smoke shall be allowed to come out of the exhaust pipe. It is wholly unnecessary and is simply an evidence of carelessness or incompetence. That the use of acetylene headlights within the built-up portions of the city should be prohibited.

If judiciously put into force, the regulations cannot be otherwise than beneficial to all users of the road, not excluding automobilists. Their practicability has been conclusively proved in European cities, where all the regulations have been in force for several years. The only case in which any hardship might occur would be in suppressing the smoke nuisance. It is here that the police ought to act discriminately. As to the other proposed regulations, they could not be applied too rigorously.

### A. A. A. EXECUTIVE COMMITTEE HOLDS SESSION.

A meeting of the executive committee of the board of directors of the American Automobile Association was held Tuesday afternoon, January 7, at Association headquarters, New York City, President W. H. Hotchkiss presiding. Only routine Association business was considered.

### HOME HONORS FOR PRES. WM. H. HOTCHKISS.

BUFFALO, N. Y., Jan. 6.—President William H. Hotchkiss of the American Automobile Association last week was elected president of the Erie County Bar Association, which gives an indication of the home appreciation of the energetic president of the national automobile organization.

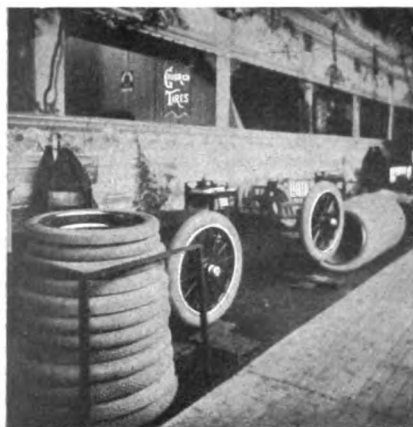

AT THE GOODRICH STAND.



WHERE THE FISK PRODUCTS WERE ON VIEW.

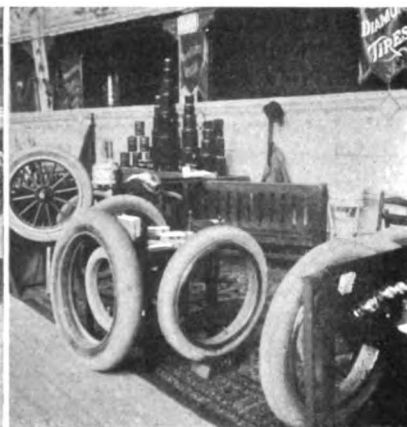

DIAMOND TIRES WERE PLENTIFUL.

## IMPORTERS EXPRESS SATISFACTION WITH SHOW RESULTS

**S**ATISFACTION as the result of the week's efforts was expressed everywhere on the ground floor of Madison Square Garden when the Importers' Automobile Salon closed its doors and turned out the lights late on Saturday night last. Without exception, the importers of foreign cars declare good business was done, that prospects are bright, and that they have nothing but praise for the experimental Garden show.

Up in the gallery rather a different tune was hummed, the keynote of which was not altogether joyous. Thin attendance, though it may be everything that one can desire in the matter of quality, cannot make up for quantity when it comes to selling articles of common utility retailing at a low figure. "Altogether we have laid down about fifteen hundred dollars during the week," said the manager of one of the largest accessory stands, "and have very little to show in return for it. The people we expected to see have not responded to our invitations, and though there may have been plenty of car buyers we require the thousands who cannot purchase a car every few months but have always some money to spend on useful accessories and appliances."

### Mr. Mabley Says There'll Be Another.

How it looked through official eyes was told by C. R. Mabley, general manager and secretary of the show committee, in a talk to THE AUTOMOBILE representative. "We have every reason to be satisfied with the Importers' show. I am rather sorry for the accessory men, for they have not done the business they expected to do; but every car exhibitor records good sales and excellent prospects for the coming season.

"Is the popular estimate of \$60,000 as expenses exaggerated?"

"Well, \$50,000 will not be far off the exact figure. Even apart from gate receipts, our show income is sufficient to pay all ex-

penses in connection with the exhibition, and when we close down we shall have, if not a balance in hand, at any rate a square account. From many standpoints it is a pity that there should be three different automobile exhibitions in New York, but there has been nothing in this exhibition to dissuade us from holding a second independent Importers' show next year on similar lines."

André Massenat, chairman of the show committee, and head of the Panhard & Levassor agency, said: "The show has been an unqualified success. Attendance has not been as high as we expected it to be, but we have had the right class of people, people who came with the avowed intention of buying cars, and did buy. I have assured myself by personal inquiries of every car exhibitor that good business has been done. As to the accessory exhibitors, I have only come in contact with two or three of them, and consequently cannot state what their impressions are. Everywhere we have been congratulated on the artistic arrangement of the exhibition and the practical placing of the cars and chassis in such a way that visitors could conveniently examine them in every detail, it being distinctive of this show that the majority of those attending it were connoisseurs of automobiles, who would not have been satisfied with a crowded group of cars. In principle it is already decided that an independent Importers' show shall be held next year. As to what lines it will take, whether it will be held here or elsewhere, cannot be determined at such an early date, but in principle we are decided to again run our own show."

Paul Lacroix, manager of Renault Frères selling branch: "Decorations and general display have made this show the finest spectacular automobile event New York has ever seen. From a business standpoint we have found it the best show in which we have participated. Attendance has not been large, it is true, but

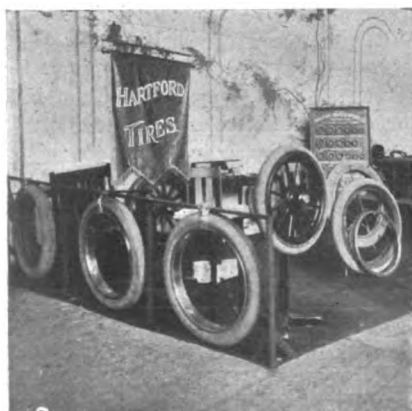

WHERE THE HARTFORDS SHOWED.

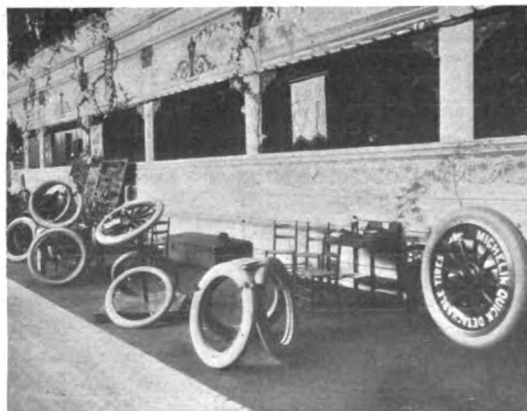

TIRES AND RIMS AT THE MICHELIN STAND.

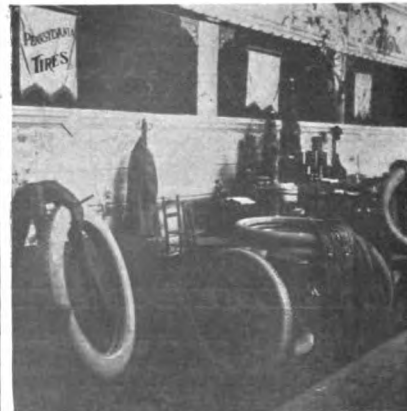

AT THE PENNSYLVANIA EXHIBIT.

we did not want persons interested in \$900 cars, for none of us attempt to supply such an article. People interested in high-class automobiles, able and willing to buy them, were desired, and we have had them in sufficient quantities to satisfy everybody. From our own business standpoint there is nothing but praise for the show, and our prospects for the year are so good that, in addition to an extended Eastern trade, we have made arrangements for direct Renault representation in the West, notably in Chicago and San Francisco."

Percy Owen, agent for the Bianchi car: "When this show was proposed we conservatively took a small space, believing that it would be sufficient for our needs. I regret now that we did not secure the maximum space allowed, for business results, by which I mean actual sales and not merely inquiries, have been far above expectations. To me the show has proved not only that there is a real interest in high-class foreign cars, but that a trade show is a much more successful proposition than the big national displays. At the latter you attract crowds of idlers with no other object than to see the sights and collect catalogues, only to throw them away. Here the idle, uninterested visitor has been conspicuous by his absence; those who came entered the show with a view to examining the cars preparatory to buying. One of the lessons which it has taught me is that importers should maintain a permanent exhibition, naturally planned on a more economical

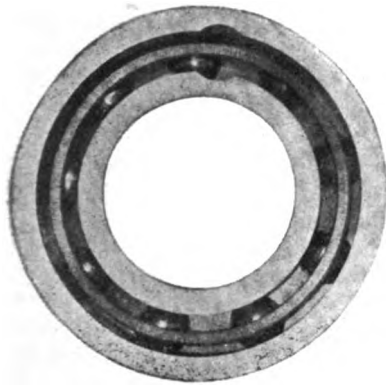

R. I. V. BALL BEARING.

scale, but still following the general lines of this, where out-of-town visitors could examine under one roof all the principal models of foreign automobiles. Importers have not agencies throughout the country as in the case with American constructors, and they should, in consequence, offer some central point where it would always be possible to examine and obtain particulars of their cars. In this connection the Motor Mart naturally suggests itself as a central exhibition hall."

M. Neubauer (Delaunay-Belleville): "I believe I am correct in stating that the volume of business at this show has been equal to that of either the A. L. A. M. exhibit or the independent exhibition at Grand Central Palace. We have not sold the same number of cars, but all our sales having been of high-class and high-priced vehicles I believe that their total will form a record for this season's New York shows. Our own feeling is one of complete satisfaction. No mention of future plans has been made to me, but I see no reason whatever why we should not repeat the Importers' show next year."

#### Some New Things in the Accessory Division.

At the end of a series of automobile shows, in one or more of which all the numerous accessory makers have taken part, it was not to be expected that there would be a very fertile crop of novelties in appliances for use on or around automobiles. Naturally, where any particular novelty had been produced in the interval between last season and the present period of shows, it was endeavored to procure it in time for the initial exposition, and thus obtain the maximum of publicity. It is for this reason that the accessory stands at the Importers' show on the whole presented well-tried and standard lines, or novelties that were no longer entirely novel.

There were a few exceptions, either of things that appeared to have been overlooked in previous exhibitions or for some reason or other only turned up at the end of the show season. At the Bianchi stand M. Bousquet, European selling agent for the Bianchi

car, showed an air pump and self-starter designed to be fitted to any automobile. The compressor consisted of an air pump designed to be driven off the main shaft, or any other convenient position. For use as a tire pump no other connection would be necessary than a length of tubing sufficiently long to lead to any of the wheels.

When the pump was desired as a self-starter, it was used to compress air into a tank\* from which it could be admitted to the cylinders through a distribution valve timed off the camshaft. The inlet device had been designed on simple lines.



A TABLOID MEDICINE CHEST.

A better known automatic tire inflator, recently introduced to America, was the Delpeuch, consisting of a compact cast-steel cylinder with supports, intended to be fixed in such a position on the car that the sliding pinion on its crankshaft could mesh with a toothed wheel on the driving shaft of the car. Generally between the clutch and the gearbox is found to be the most suitable position, though where no length of shaft is available here any other position can be selected. The inventors declare that no car has yet been found on which it could not be fitted. To put the pump into operation all that is necessary is to slip the sliding pinion into mesh, this being easily done by a command brought up to the dashboard. The automatic inlet valve is fixed in the piston head and the outlet valve in the cylinder head. A manometer and a rubber pipe completes the equipment. For work in garages a larger pump is made, with a water-cooled cylinder.

Léon Rubay's new production was the Gillett-Lehmann gasoline economizer, which, after considerable success in Europe, has been introduced to the United States. Claims made for the device are a saving in consumption of gasoline, increased power, and the avoidance of offensive exhaust gases. It consists of an adjustable air valve or plug screwed down to the top of the float chamber and connected with the small-bore tubes to the induction pipe, one attached on the engine side of the throttle and the other on the jet side. These are known as the balance pipes. The pressures on either side of the throttle are always varying with every movement of the throttle, but as both small pipes lead to the same small chamber in the economizer a mean pressure is created there, and it is thus that it exerts its economizing influ-



HEAVY DISMOUNTABLE TIRE BEING FIXED ON ITS RIMLESS WHEEL.



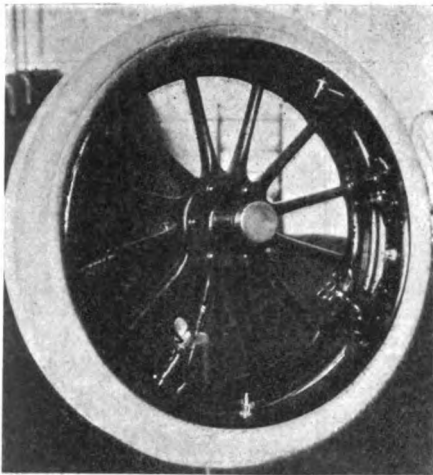

HOW THE STEPNEY WHEEL IS FITTED.

ence. It is claimed that every type of automobile can be fitted with the device without difficulty.

A new type of ball bearing introduced from Europe formed one of the attractions at the stand of the Auto Supply Company. To get away from the objectionable breakage of the cage holding the balls in position, the R. I. V. bearing has been made with an anti-friction ring cast

around the balls after they were in proper position in the bearing, but sufficiently free to allow them to revolve freely. The ring serves the double purpose of properly spacing the balls with a cage that is indestructible and assists in the proper distribution of the lubricant.

A medicine chest is generally too bulky an article to find a position on an automobile, much as its presence would be appreciated at certain times. At the booth of the Auto Supply Company the want was met in what appeared to be a perfect manner, a compact japanned metal box, no larger than the road book many an automobilist carries along with him, containing no fewer than twenty-five articles intended for first aid in the absence of a medical man or before his arrival. Just as an indication of how space was economized, a supply of cotton wool, which ordinarily would alone have filled the box, was compressed into a small package a couple of inches in length. Practically everything necessary for the treatment of minor accidents, burns or cuts was to be found in the case. At the same stand tea was treated in a similar manner, being compressed into small tabloids, two of which would furnish sufficient beverage for about three people. Sugar is supplied in the form of "Saxin," declared to be six hundred times sweeter than the commonly employed article, and of course compact in the same degree.

The only detachable rim on exhibition which had not been seen at previous shows was to be found at the stand of the Healy Leather Tire Company. Distinctive in the device is the absence of a wooden, steel-bound felloe, making a double rim, as employed on nearly every other make. The dismantlable rim is attached by means of a clip at the end of each spoke. Thus by the suppression of the wooden felloe and one steel rim the Healy device is as light, if not slightly lighter than the ordinary type of fixed wheel. Conversion of an ordinary wheel to a dismantlable is a simple matter and one costing but little. The metal rim is taken off and retained, the wooden felloe knocked off and discarded, then the end of each spoke cut down and turned to receive a steel socket with a couple of case-hardened lips, one fixed, the other attached by a nut and bolt, but not entirely dismantlable. It will be immediately noticed that the ordinary lugs and valve can be retained, an advantage which will be appreciated by the practical automobilist. In addition to the lip at the end of each spoke binding the face of the rim, there is the usual expanding motion on the entire rim, which should theoretically make a perfectly safe unit. According to the statement of the manufacturer, experiments carried on throughout the summer have proved the dismantlable wheel to be more than equal to the strains of a heavy car over the worst roads.

Though a newcomer to America, the Stepney wheel, shown at the Garden, is no longer a stranger, its own merits having brought it quickly before the public during the few months it has been on this side of the Atlantic. In brief, it consists of a metal rim without felloe, spokes, or hub, on which is carried an inflated tire. When not in use the wheel is carried on the side of the car in exactly the same manner as a spare shoe. On a puncture occurring, the deflated tire is left undisturbed, and the Stepney attached to the wheel by means of three or four clips—according to size of wheel—fitting over the clincher lip of the permanent wheel. Two of the clips are rigid and two are adjustable by thumb nuts, all that is necessary to secure the wheel being to get the fixed clips in position and tighten up on the adjustable ones, the use of a jack under ordinary circumstances being superfluous. To prevent creeping of the Stepney around the fixed wheel, a metal lip on the smaller sizes engages one of the spokes. For the largest wheels a couple of leather straps are passed around the clip and a spoke. No tools whatever are required for mounting the wheel, the time occupied is but a few minutes, and the Stepney can be run hundreds of miles with safety.

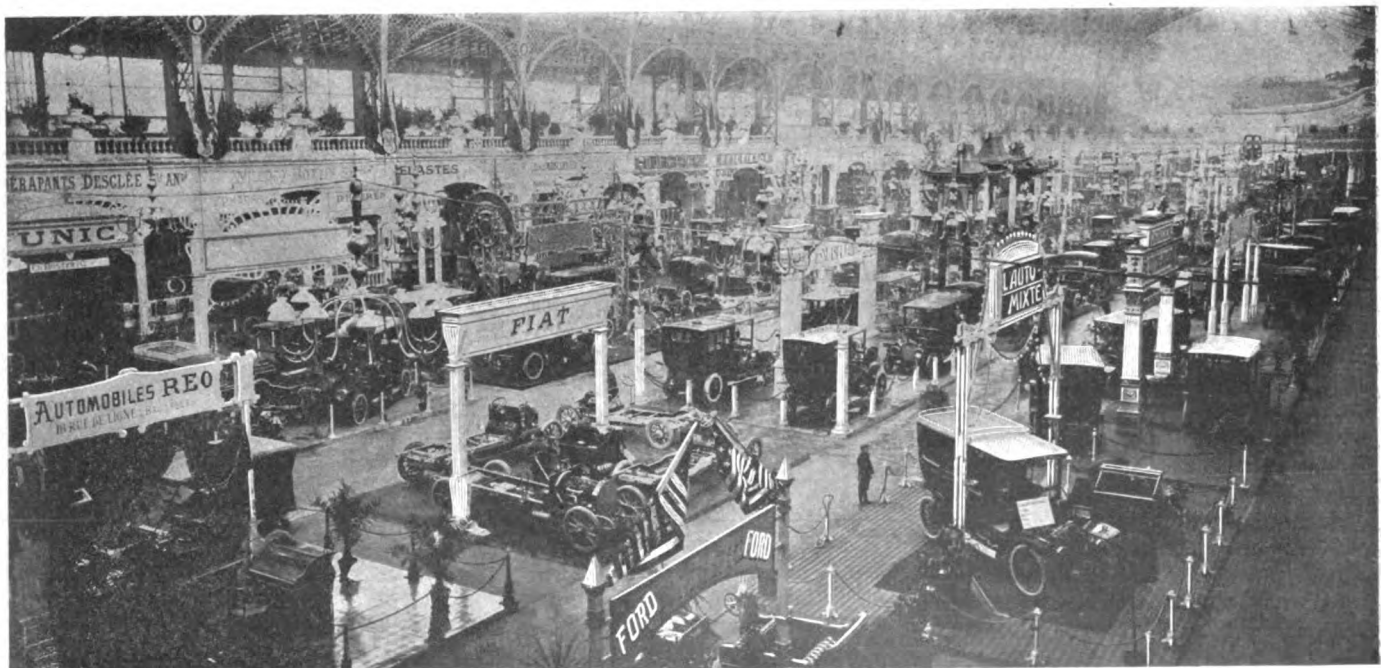

BRUSSELS SEVENTH ANNUAL AUTO SHOW, SECOND ONLY TO PARIS IN IMPORTANCE, HAD FORD AND REO IN FOREGROUND.

## SEVEN DISTINCT EVENTS FOR ORMOND-DAYTONA CARNIVAL

WITH the addition of a stock chassis race to the program of the Ormond-Daytona speed carnival, from March 2 to 7, there are now seven distinct events for the world's fastest straightaway track. According to the entry blank issued by the Contest Committee of the Automobile Club of America, the stock chassis event will be five times round the 32-mile course, giving a total distance of 160 miles, and will be eligible to any American or foreign chassis, the maker of which shall have manufactured and delivered, or be ready to deliver before February 15, 1908, ten chassis similar in every respect to the one entered. No restrictions are placed on the body, other than that provision must be made for two persons and that a mechanic must ride along with the driver. Total piston area has been limited to 103.87 square inches, which will admit the equivalent of a four-cylinder engine having a bore of 5 3/4 inches. The prizes in the stock chassis event are a silver cup to contestants finishing first and second; entrance fee is \$100.

All other events are announced to be run under Vanderbilt Cup race conditions, limiting the weight of the car to 2,424 pounds. The center of attraction should be in the contest for the Automobile Club of America Cup, nine times round the course, or 288 miles, in which event some of the cars built for the last Vanderbilt Cup race should participate. Event No. 2 is a four-lap race for gentlemen amateur drivers, the trophy being a silver cup.

In the 100-mile race for the Minneapolis International Championship Trophy, won successively by a Napier car entered by S. F. Edge and by E. B. Blakely on an American Mercedes, entrance fee has been fixed at \$50. In this event, as well as in

the other long-distance races, the referee shall have power to make the starts as he may deem proper should entries be large.

Three short-distance events, for the Sir Thomas Dewar Trophy, the Two-Mile-a-Minute Trophy, and mile and kilometer records can only be entered by cars which have participated in the long-distance races, or accomplished a distance of 100 miles at an average of 60 miles an hour.

All events will be conducted under the Racing Rules of the American Automobile Association, over a 16-mile straightaway with loops at each end, affording a circuit of approximately 32 miles. As far as possible starts will be made at the clubhouse of the Florida East Coast Automobile Association, where the grand stand and officials will be located; the exact time of starting to depend on the tide and condition of the beach. The rule requiring contestants to be in the enclosure designed for them at least thirty minutes before the start of their race will be strictly enforced. All events, declares the official entry form, will be confined to white male drivers eighteen years of age or over. Entries, which should be addressed to Robert Lee Morrell, chairman of the Contest Committee of the Automobile Club of America, will be received until midnight on February 15.

Chicago Automobile Club's first entry for the Florida carnival is announced as G. F. Sulzberger's six-cylinder Stearns, which carried off the speed laurels in the Harlem track races last October. It is intended by the Racing Committee of the Chicago Club to organize a special train from the Windy City to Ormond in connection with the races. Chairman Gregory, Joseph F. Gunther, and Walden W. Shaw have charge of the arrangements. A big Western delegation is expected.

## THREE MORE BRITISH ENTRIES FOR FRENCH GRAND PRIX

PARIS, Jan. 1.—England is coming out stronger for racing next season than was generally expected, for in addition to Ariel, already officially promised for the Grand Prix, Weigel has this week sent a letter in which he declares that in six weeks he will be over in Paris to show off his racers for the Blue Ribbon of the automobile world. Weigel is England's plucky but unlucky aspirant for speed honors who last year built a couple of eight-cylinder racers—which, by the bye, he now calls touring cars—and received as his reward a condemnation to one month in prison, without the option of a fine, for exceeding the speed limit. Naturally a protest was made, Weigel maintaining that the police had got mixed up on the cars, that his own machine had a slipping clutch and could not get on at all, and execution was suspended while the legal machinery went into operation.

The three machines for next year's race will have four, not eight, cylinders, bore being the maximum of 155 millimeters. What other features they will possess Weigel fails to say, except that they will, naturally, be marvelously fast and give the Frenchmen, Italians, Germans and Belgians a stern chase.

No decision has been arrived at regarding the choice of a circuit, Dieppe standing favorite, but half a dozen other districts are doing their best to attract the favorable consideration of the Racing Board. The suggestion has been put before the committee that if the Dieppe course is selected the race should be held in the opposite direction, the cars traveling in the same way as the hands of a clock, and that the tire and gasoline stations be placed opposite the grandstand, as was done so successfully in the first Grand Prix race on the Sarthe course.

## SPECIAL CASH PRIZES FOR THE WESTCHESTER RACE

TWO certified checks of the value of \$750 and \$500 have been sent to Chairman Robert Lee Morrell as special prizes in the race for the Briarcliff Cup, planned to be held over a Westchester County, N. Y., course in the spring. The larger amount came from Joseph Gilbert, American manager for Continental tires, with a request that \$500 should go to the driver of the first car using Continental tires, and \$250 to the driver of the second car similarly equipped. Alexander Dow's check for \$500 is to be used as a cash prize to the driver finishing first with an equipment of Dow non-deflation inner tubes.

A knotty question confronts the Race Committee, as the result of Mrs. A. N. Cuneo's decision to enter the stock chassis race with a 45-50-horsepower Rainier, which she has recently

purchased. Thomas F. Moore is reported to have replied that he would personally like to accept the \$1,000, but that he has misgivings as to what his committee would say on the matter. Should the committee make up its mind that the lady's entry shall be accepted on the undisputed ability of the applicant to handle a car in a speed contest, then the check will be taken and the anger of the ungallant ones borne bravely. Meanwhile the secretary is waiting, with a blank sheet before him, to record the names of those itching to hand over a thousand-dollar note for the privilege of contesting the Briarcliff Trophy. When thirty cars have been received the lid will be put down tight, for the committee has decided that it will only accept one car for each mile of the course, and will make no further concession.

## NEW YORK'S LEGAL AUTOMOBILE SITUATION CONFUSED

ALBANY, N. Y., Jan. 6.—Henceforth the lot of the autoist in New York City will be more interesting in that he may have an opportunity to choose under which law he wishes to be apprehended for violating the speed limit. If he drives more than eight miles an hour, but less than ten, it is then the duty of the first policeman who sees him to take him into custody on the charge of having violated the municipal ordinance, for which the maximum penalty is a \$10 fine. If his car happens to go eleven miles an hour, the same policeman may take him in, in the same manner, on the charge of having violated the Motor Vehicle law, under which the penalty may be anything up to a \$100 fine for the first offence; \$100, or thirty days, or both, for the second offence, and \$250, or thirty days, or both, for the third offence. So says, in substance, the decision of the Court of Appeals, handed down last week in the case of the *People vs. Hainer*, the opinion being by Justice Willard J. Bartlett.

W. M. Hainer is the chauffeur of Edward J. Flammer, a New York lawyer, and he was arrested in June last, charged with having driven his car at the rate of eighteen miles an hour. His employer contended that he should be fined under the city ordinance and released, but the magistrate before whom he was brought took a different view of the matter and held the driver for Special Sessions. Mr. Flammer procured a writ of habeas corpus, pending the calling of the trial, and Hainer was ordered discharged by the Special Term of the Supreme Court, before which the writ was argued. The people appealed, and pending the decision of the case by the Appellate Court, the city magistrates followed the ruling of the Supreme Court and violators of the speed law were uniformly subjected to a fine of \$10. Then the Appellate Division of the Supreme Court reversed the finding of the Special Term, and Mr. Flammer appealed to the Court of Appeals, which has just affirmed the decision of the court below in the manner already referred to above.

But in doing so, it does not appear that the court of last resort undertook to ascertain whether the municipality of New York had complied with the conditions precedent, giving it the right to pass a speed ordinance of its own under the Motor Vehicle law. The chief of these is that the speed limit so set shall apply to all vehicular traffic, and this has been complied with by the uniform restriction to eight miles an hour, but a second, and so far as the validity of the ordinance in question is concerned, an equally important condition, is that of placing signs at street corners, such as are commonly seen in the rural districts, stating the permissible speed. In this respect, New York City has failed to comply with the provisions of the State law, as such signs are only to be found in the parks. In view of this it would seem that arrests under the local ordinance could not be upheld until such signs are erected, though the majority of autoists would naturally prefer the lesser of two evils in the shape of the \$10 fine limit of the latter, to the much heavier penalties of the State law.

In its decision, the Court of Appeals takes the position that both the Motor Vehicle law and the municipal ordinance are in full force and effect concurrently, and that when a driver is arrested for having run at a speed of more than eight miles an hour, but less than ten, he is subject to nothing more serious than the \$10 fine provided as a maximum penalty in the latter, while if he exceeds ten miles an hour, he may be apprehended under the State law and either fined heavily within the limits of the penalties provided therein, or even held for trial in Special Sessions and have a bit of involuntary waiting at the city's expense thrown in should the verdict go against him.

The situation is an interesting one, in that it reveals the confusion that is bound to arise in permitting municipalities to pass their own speed ordinances, even under the restrictions of the present Motor Vehicle law.

## GLIDDENS AGAIN OFF ON THE 'ROUND-THE-WORLD TRAIL

IN a short time Charles J. Glidden and Mrs. Glidden will recommence another phase of their self-imposed automobile pilgrimage, which has already taken them a distance of 42,367 miles and brought them in connection with thirty-five countries of the world. Since 1901, when the long ramble up and down the surface of the globe was commenced, new roads have been built, making further conquest possible, and it is now the intention of the doyen of automobile travelers to explore further into the Turkish domains and the countries encircling the eastern end of the Mediterranean.

To explore the new fields by automobile and drive in the oldest countries, headquarters will be established at Alexandria, Egypt. There is in this city a well-appointed automobile garage and drives can be made to places of note. West of the city, by aid of the compass, a journey will be made well out on to the Libyan desert beyond the recently-discovered city of Abu Mina, proceeding over the billiard-floor surface of the desert until it becomes too rough for driving, though a good surface is assured for two hundred kilometers.

Retracing the drive over the desert to Alexandria, it will be possible, though not easy, to follow up the Nile Delta to Cairo, the principal trouble being at the bridgeless streams, or at rivers where bridges are not strong enough to carry the automobile. The Gliddens have had experience of this kind and are familiar with the work necessary to strengthen a bridge.

Cairo is 130 miles from Alexandria, and the excursions in Northern Egypt on the desert to the oasis and return ought to total about 500 miles. Drives south and east of Cairo to the

Pyramids of Gizeh, thence across the desert to those of Abusir and Sakkara, can be accomplished, and a good road runs from Cairo to Suez. By the middle of March, Egypt ought to have added 1,000 miles to the total distance covered by the Glidden party. Writes Mr. Glidden:

"It would be a hazardous undertaking to drive from Cairo to Jerusalem across the desert, as the Syrian coast is cut up by unbridged streams running down from the mountains, and the trail is principally a pack caravan route often infested with hostile Kurds. The sand of the desert in this section of Syria is soft and deep. It will therefore be necessary in order to reach Syria to ship the car from Egypt to Jaffa, from which place a good road runs to Jerusalem, the Dead Sea, the Jordan, and other points of interest. To reach Upper Syria it will be necessary to return to Jaffa and sail to Haifa, motoring from this point over the mountains of Samaria to Nazareth and the Sea of Galilee at Tiberias. Returning and sailing from Haifa, the next point in Syria will be Beirut. From this place a good road is assured to Damascus, Homs, across the Syrian desert to the ruined city of Palmyra and possibly to Babylon and the Euphrates, making a total drive in Syria of 1,500 miles.

"Carriages now run across the desert, which is smooth and hard, from Bagdad to Aleppo, and on this route there have been established post houses with sleeping and dining accommodations. It will certainly be unique to travel by automobile to these remote places in Western Asia, and the same car which has stood on the banks of the Ganges and in many sacred places in the world is now destined for the Jordan and the Holy Land."

## CLEVELAND MAKERS LOOKING FORWARD COMPLACENTLY

CLEVELAND, Jan. 6.—Cleveland manufacturers and dealers are looking forward to the year with a great deal more complacency than was the case a month or six weeks ago. The financial condition is showing daily improvement, and real money is rapidly displacing the clearing house checks. Manufacturers in all lines who have laid off men are calling them back to work, and one of the best indications of renewed prosperity is the fact

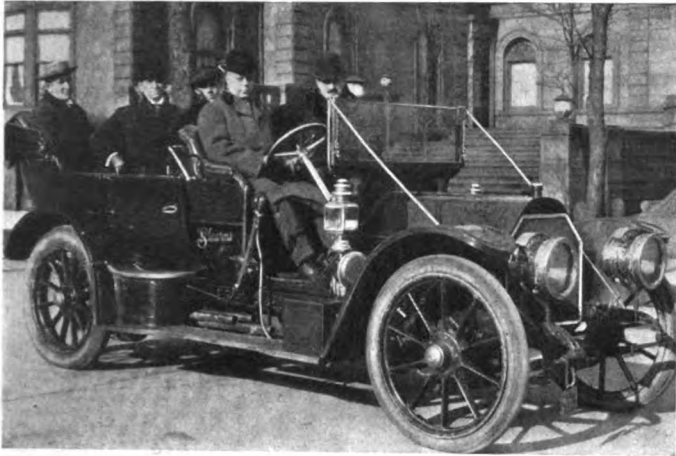

SALES MANAGER R. F. YORK AT WHEEL OF 1908 STEARNS.

that collections are improving from all quarters. This general improvement in business conditions leads the automobile people to believe that while the business for the next month or so may be a little below the average there will be a splendid spring business. The local dealers are congratulating themselves that they decided to hold the local show in February instead of following

the example of the national shows. There is every indication that the actual business at the Cleveland show, which has always been large, will be greater than ever before because of the delay.

One of the best indications of the feeling of optimism is shown in the case of the F. B. Stearns Company, which throughout the financial stringency kept steadily at work on a large addition to its factory. This addition is now completed, and adds greatly to the company's capacity. R. F. York, of the Stearns Company, is now in California, and he reports that the company will get a very nice business from the coast this year. The Stearns factory is running practically a full day force on cars for immediate delivery.

The Peerless Motor Car Company has increased its working force within the past week or so and it now has about three-fourths of full force on full time. It reports that it has on hand more specified orders up to date than the same time a year ago. Business is reported remarkably good in view of general conditions. The Peerless branch at Boston has sold more cars to date than were sold up to March 1 last year.

A. R. Davis, of the Garford Motor Car Company, reports that business is most satisfactory. Two large limousines were sold last week to prominent Clevelanders, and agents are sending in an increased number of orders.

The Winton Motor Carriage Company is working a good-sized force for this time of year and is shipping many cars. All of the branch houses are reporting brighter prospects.

The White Company has practically a full force and is shipping about as usual. Walter C. White, vice-president of the White Company, who has just returned from London and Paris shows, says that foreign trade in Whites will be heavier than ever.

The Baker Motor Vehicle Company is working on large outputs of electrics for 1908.

## THE AUTOMOBILE IS IN THE NATURE OF AN EVOLUTION

"THE automobile is bound to become one of the most stable in the United States," says B. A. Becker, of the Elmore Manufacturing Company, "for those concerns which have an output that is progressive and meets public demand.

"The automobile is in the nature of an evolution, and no evolution can be stopped; in fact, you can no more get along without the automobile to-day than you could without the horse. It annihilates distance better than any locomotive that has ever been built. It brings people out into the open air and invigorates the human system in a better manner than by any other means now in vogue. It combines three very essential points: the most comfortable means of travel, the betterment of health, and the supreme enjoyment of outdoor living.

"Compared with other years we have shipped more of this season's machines up to date than ever before in the history

of our plant. In fact, if we should not make more 1908 cars than we did 1907 cars, we have already shipped almost exactly one-quarter, or 25 per cent., of our output.

"From the present indications, it would appear that 1908 would be one of the best years that we have seen in the automobile business. Present conditions have not affected us up to date, and we consider that it is only a question of a short time when conditions will be normal.

"There is too much pessimism, we believe, in the business world to-day, and it disagrees with our ideas of things, as shown by the fact that we have more men on our pay roll at this time than we had at the same time last year. Our output, as in previous years, has all been contracted with a considerable extent of very desirable territory still open, which we would like to enter, and which will compel us to increase our output."

## AUTOS HAVE BECOME A NECESSITY, NOT ENTIRELY A PLEASURE

"It is really amusing when I hear these pessimistic rumors regarding the lessening of automobile sales," said Benjamin Briscoe, Chairman of the Committee of Management of the American Motor Car Manufacturers' Association. "I presume these rumors are started by some irresponsible salesmen because a few orders for automobiles have been canceled. Because the water is being squeezed out of many worthless stocks and some institutions have been tottering, the reports have been flying broadcast that the demand for automobiles had been met.

"Any sane and broad-minded individual who has studied the situation knows that automobiles will always be sold. They have become a necessity, not entirely a pleasure. It has reached a stage when the public cannot do without them. Especially is this true in the commercial line. Motor trucks and delivery wagons cannot be turned out fast enough to meet the demand. If there is any salesman who feels he has sold all he can, the sooner he gets into some other business so much the better, considering the demand, especially for town cars, is very good."



## DETROIT FEBRUARY SHOW TO BE A NOTABLE AFFAIR

**D**ETROIT, Jan. 6.—From the automobile show of a half dozen years ago to the one of the present day is not a long hark in point of years, but it reveals some startling developments in cars. Possibly nowhere else in the country has this evolution been more forcibly emphasized than in Detroit, which was the first city in the country to have a local automobile show. It was a primitive affair, according to present standards, but six years has worked wonders, and at the time it attracted widespread attention. It is worthy of note that since its inception the pioneer show has been held under the name of the Tri-State Automobile and Sportsmen's Show, the seventh of which is underlined for February 10-15 at Light Guard Armory.

The original display contained a half dozen models of steam cars, nearly all of which are now unknown, and a single gasoline

car, made in Detroit. For the February show, Manager E. E. McMasters announces there will be twenty-five agencies and factories taking space, approximately fifty different makes of cars being exhibited. Applications were far in excess of this number, but it was found necessary to limit the exhibitors through lack of sufficient room to care for all.

As in the past, the gallery will be given over entirely to accessories. The drill hall in the basement will be devoted to a display of motorcycles, which promises to be most comprehensive.

When the Detroit Automobile Dealers' Association launched its recent show at Riverview Park it was predicted that would put an end to the old one. Quite the contrary, the interest displayed in the Tri-State show is greater than ever, indicating that it will equal if not eclipse all predecessors.

## CLEVELAND'S FEBRUARY SHOW LARGER THAN EVER BEFORE

**C**LEVELAND, Jan. 6.—Specification blanks for the Cleveland show, to be held February 17 to 24, were sent out last week by Manager George Collister. The plans provide for a larger exhibit than heretofore, as the large banquet hall at the north end of Central Armory, heretofore never used for show purposes, has been secured and will give 5,000 more feet of floor space. This will be used largely for motorcycles, bicycles and accessories.

The balconies of the big hall will be used exclusively for accessories, while the main floor and wings will be used for complete automobiles. Only the limitation of space will prevent all the cars represented in Cleveland from being displayed, for with daily improvement in the outlook for business every dealer is anxious to get into the show. The show promises to eclipse last year's successful exhibition by fully fifty per cent.

## POUGHKEEPSIE OFFERS GLAD HAND TO FRENCH FIRM

**P**OUGHKEEPSIE, N. Y., Jan. 6.—It is hoped that the De Dion Bouton Company, of Suresnes, France, will be induced to locate its factory in Poughkeepsie. A representative of the French firm is investigating positions on the Hudson, and has already considered the claims of Albany and Newburgh, but it is believed that Poughkeepsie, with its railroad connections open to all parts and a waterway to the ocean, will be able to carry the day. The Chamber of Commerce has invited the representative to visit the town within a few days to look over the situation and review the advantages of the location. The impression is that the new firm does not desire any bonus, but it must have accommodations for its machinists and workmen, who will probably number about three thousand.

The De Dion Bouton Company, one of the oldest and largest in France, had a certain business connection with the United States in the early days of automobiling, supplying motors and parts to several firms now regarded as being at the head of the American industry. Of late years the business done here has been practically nil, the few imports being parts or an occasional commercial vehicle. The French works, on the banks of the Seine outside Paris, are devoted to the production of touring cars, stationary and automobile engines, and commercial vehicles, this latter class being now particularly important. Three thousand workpeople are employed, the annual pay roll being one million dollars. It is supposed that the American factory will be occupied largely with the production of commercial vehicles.

## A. C. OF SPRINGFIELD HEARS ABOUT IGNITION.

**S**PRINGFIELD, MASS., Jan. 6.—J. O. Heinze, of the Heinze Electric Company, Lowell, one of the foremost electrical experts in the country, gave a very instructive technical talk before the Automobile Club of Springfield, January 2, on "Magneto and Coils." Before engaging in business for himself, Mr. Heinze was assistant to Professor Elihu Thompson of the General Electric Company. At the St. Louis Exposition he received highest awards for the construction of the most powerful induction coil.

The subject taken up by Mr. Heinze was confined to the relative merits of the magneto and spark coils as applied to automobiles. The speaker was emphatic in his statement that a magneto produced a greater efficiency in the gasoline engine than the spark coil, and that the auto can go farther on a gallon of gasoline when the gases are ignited by the spark of a magneto than by the spark of a coil. Instruments designed by Mr. Heinze were shown which disproved the commonly accepted theory that by advancing the spark early ignition is secured. The instrument showed that the spark at all times takes place at the highest point of compression.

## MARYLAND MAY REBUILD OLD TURNPIKE.

**C**UMBERLAND, Md., Jan. 6.—Activity in the development of highways is clearly manifested in Maryland by the strong support which is being given the proposal for a State road or one main artery controlled exclusively by the State. The matter has been talked of for some time, and has been introduced to the Legislature, but was received at such a late stage of the session that its consideration was impossible. When the Legislature again meets this month the subject will be brought up, when it is hoped that the bill will pass into law. The State road, which when rebuilt would reach in Allegheny county from Flintstone to Grantsville, would be a great boon to tourists going over the old National Pike and the Baltimore Turnpike.

At a recent meeting under the auspices of the road directors of the county, in Cumberland, a resolution was adopted that a bill be framed and presented to the Allegheny county delegation for passage at the coming Legislature calling for a bond issue of \$125,000 for permanent road improvement, an equal amount to be secured from the State under the provision of the Shoemaker fund.

OPTION GIVEN ON POPE-TOLEDO PLANT.

TOLEDO, O., Jan. 6.—It is reported that at the meeting of the creditors of the Pope Motor Car Company and members of the Toledo Chamber of Commerce, held here last Friday, and which was presided over by the receivers, George A. Yule and A. L. Pope, that an option on the entire Pope-Toledo plant has been given to Joseph M. Schwab. Nothing definite regarding the terms of the agreement has been made public, but it is understood that the consideration is \$800,000, of which Mr. Schwab will pay \$650,000, Toledo interests raising the balance.

A QUAKER GIRL WHO KNOWS HER CAR.

When John Megraw, one of Philadelphia's prominent real estate men and capitalists, bought his daughter a Wayne roadster he little dreamed that he was performing a stunt that would develop his daughter into a veritable mechanic. But such was the case, and now, whenever any repair is necessary about the house, the Wayne enthusiast is first consulted before a mechanic is engaged to make the repairs.



MISS MEGRAW IN HER WAYNE.

So much does Miss Megraw think of her car, and so enthusiastic is she over its possession, that she jealously refuses to allow anybody to touch the auto insofar as the operating mechanism and its upkeep are concerned. If the gasoline tank is empty it is Miss Megraw who carries the can and fills the tank with the gas supply. If the oil pump is dry, it is Miss Megraw who raises the hood and fills the oil case with the lubricant. If the vicious nail or tack plays havoc with a tire, or if a plug ceases to spark, or if anything occurs that requires any attention, it is not a chauffeur or mechanic who attends to it, but Miss Megraw herself.

"I just love to putter around the working parts of my Wayne," laughed Miss Megraw as she closed down the hood after filling the crankcase with oil. "While I have never really had any trouble with my car, I tinker around a good deal just to satisfy my curiosity. I have driven all over Philadelphia during the past season, and now I am planning for some real tours next year. I want to take some trips into other sections of the country, and it was because of my desire to do such stunts that I have fitted myself to handle my Wayne both in driving it and in keeping it in running order."

**GREETING...**

To all Ye truthful TELLERS of tangible TALES  
be it known that these BE Tight Times,  
Ye jugglers of JUNK AND parloiners of

**PARTS these be TIGHT TIMES.**  
Ye are BROKE, YE are BeSet  
COMETH ye CAUS'TIC CrEDiTOr with an Club,  
A vEakY PReSEnCE eHAT PrUmth YOu,  
GLUm and eERy to ERASE YOu,  
COMeth Ye Jes'lug JOE'ier Wi'Ch a JaveLin to  
JAB You, SLicing YOu'r SheKels.

Cometh the CU'somer, Cour'eous, ConsiderAle,  
WITH Ye CASh.—NOT.  
YE arE BroKE and these bE TiGHt Times.

BUT COME ye to US At ye New Year whiLe ye  
ChEerFuL CHARitY is a HanGOvE' from CHRiStmas.  
FOR THE T'WOTHLeS' WOnDeR HATH fUrniShed  
HEr UPSiAIs, aS a SaNItARiuM fOr SanitY aNd CUReH it

CoME aNd forEGather With the Cu'Reless CRANKs  
And Ho'pno'B wITH You'r Ho'pBY,  
In the BLuE ROOM,  
WhiLe OU'r DeVices  
"SLip"  
SLip O'VeR to YOU the HoT BIRD  
aNd the CoLD BOTTLE

It Be TiGHt TIMES. COME !!



Ye GeARless TRANSMISSiON Co.  
At Ye HAg Station Ro'GhEsTer,  
on Ye fOUR tRACK ROad

GEARLESS TRANSMISSION COMPANY'S NEW YEAR'S GREETING.

KNOX TO BUILD NEW FIRE TRUCK.

SPRINGFIELD, MASS., Jan. 6.—The City of Chicopee has just ordered the Knox Automobile Company to construct a new automobile combination fire truck for the city's fire department. The new auto truck will be the first of its kind ever built by an automobile manufacturer in the country, and is to cost \$5,000. The specifications call for a combination chemical, hose and ladder truck, equipped with a 1908 model, four-cylinder, 40-horsepower, three-speed, air-cooled gasoline engine. Its maximum speed will be twenty miles an hour and will be so built as to ascend grades at an average of ten miles an hour. The new auto truck's fire-fighting apparatus is to consist of two 25-gallon Holloway chemical engines, with 300 feet of hose and two sizes of nozzles. The whole outfit will weigh 7,500 pounds.

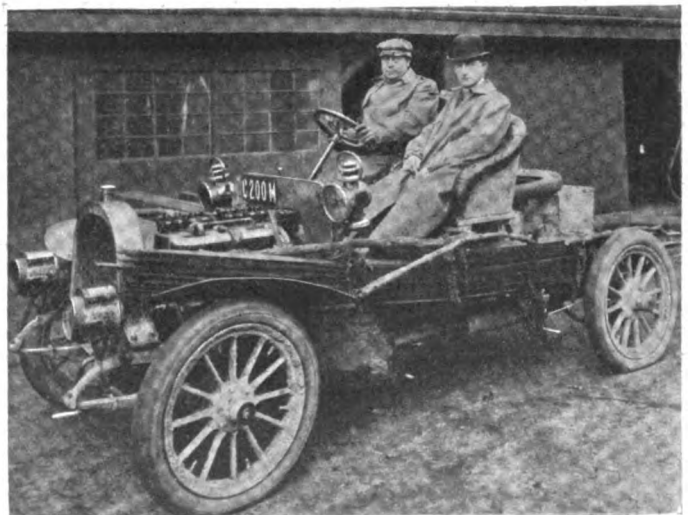

HOW THE POPE-HARTFORD BROUGHT THE DELAYED STEEL.

A few weeks ago the Pope Manufacturing Company were at a loss to know what had become of a carload of steel which had been shipped from Elyria, O., to the factory at Hartford, and as the company was sorely in need of some of the cargo it traced the car to Albany, where the car had been sidetracked. E. J. Wall, traffic manager for the company, and driver Jim Young, started in a Pope-Hartford for Albany, found the car, and loaded all the raw steel they could on it, about a ton altogether, making the total trip of over 260 miles without a mishap, within twenty hours from the time of starting.

## BRIEF ITEMS OF NEWS AND TRADE MISCELLANY

Continental tires, according to figures submitted by the makers, were more numerous than any others on the cars exhibited at the recent Importers' Salon, in Madison Square Garden.

The Cameron Car Company, of Brockton, Mass., has purchased the entire plant of the Beverly Mfg. Co., Beverly, Mass., including buildings and machinery. This plant gives the Cameron Car Company an addition of 60,000 square feet of floor space.

Still another addition is made to the ranks of the American Motor Car Manufacturers' Association by the election of the Tinscher Motor Car Company, of South Bend, Ind., which make the highest priced car of American manufacture. Their models range from \$5,500 to \$9,000. This gives 52 members to the A. M. C. M. A.

There are four Model X-I-V and two Model K Wintons in Santiago de Chile, and, according to J. S. Gilmor, they are giving "the best of satisfaction, and are all in perfect running condition. This is especially gratifying," he adds, "as the roads are abominable, the grades being rocky and steep. Their owners are enthusiastic."

Diamond wrapped tread tires, in both the quick detachable and regular clincher types, made conspicuously excellent records in the Quaker City Motor Club's endurance run January 1 and 2. Of the 49 sets of tires in use, 24 1-2 were Diamond, and their record, even under the trying road conditions, was an extremely clean one. There were 5 1-2 sets of Diamond tires on the seven cars finishing in the lead.

Never having had any springs break on his car in 30,000 miles' travel, during all of which time, however, the car was provided with Truffault-Hartford shock absorbers, Frederick Sadler, of Bloomfield, N. J., questioned their value, and removed them. In the three weeks following, two springs were broken, which quickly convinced him, and the shock absorbers have been replaced.

As an indication of the manner in which American exports of automobiles have grown during the past few years, the advance reports of the Department of Commerce and Labor for the month of November, 1907, show that for the 11 months ending with November in the years 1905, 1906 and 1907, the totals were as follows: \$2,499,010, \$4,167,032 and \$5,455,540, these figures including the value of both parts and complete cars.

As the first step in the carrying out of a new policy, the Studebaker Automobile Company has just opened a branch in Boston, and will follow it by opening branch houses in all the larger cities of the country. Aside from its other manifest advantages, the branch house brings the customer into closer touch with the manufacturer than is otherwise possible, and is an assurance that the purchaser's interests will be looked after, not merely when he first becomes the owner of his car, but as long as he possesses it.

Officials of the York Motor Car Company, of York, Pa., were well represented in the recent endurance run of the Qua-

ker City Motor Club of Philadelphia. Aside from the four cars entered and which secured second honors in two classes, Sales Manager H. R. Averill was an observer in the new Philadelphia-built Parkin car; Treasurer R. L. Stevenson acted in the same capacity in a Columbia, and General Manager James A. Kline alternated at the wheel of the 4-40 Pullman entry with Bob Morton.

A patent has been granted the Empire Automobile Tire Company, of Trenton, N. J., on a new electric wire for automobile service. The Empire secondary wire is covered with a rubber stock designed to resist high voltage, the stock being covered with braid and over the braid being placed an oilproof rubber stock. Two braided jackets are placed on the outside. A primary wire made by the Empire company is also insulated with oilproof rubber and finished with two braided jackets.

"It may be well, perhaps, here to state that along the line of progressive improvements we reserve the right to make changes in the construction of Lozier cars at any time, and in such a manner, as, in our opinion, will result in their betterment, it having always been a part of the Lozier policy to discard whatever we feel we have improved upon, and to put into immediate practice any device we have newly perfected, rather than hold it over for embodiment in a later model." The foregoing extract from the Lozier catalogue in explanation of this firm's policy speaks for itself.

Northwest Canada as a market for American automobiles is looming large, according to J. F. McLain, western sales representative of the Franklin Company, Syracuse, N. Y. Mr. McLain states that contracts for the coming season are twice as large as those for the year just past in the territories centering in Calgary and Victoria. In spite of the duty of 35 per cent., the prospects for business are said to be much better than in the Seattle and Portland districts of the United States. A number of ranch owners in the Calgary-Edmonton district are said to be owners of six-cylinder Franklins.

### NEW AGENCIES ESTABLISHED.

The Logan Construction Company has just placed its "dealership" for Cuyahoga County with the Southern Motor Truck Company, of Cleveland, O. The latter company has offices in the Citizens' Building, and a large garage at 6410-6414 Detroit avenue, and will handle the full line of Logan cars.

The Lozier cars will in future be handled by the Co-operative Motor Car Company, of Buffalo, N. Y., in that city. This firm is also the agent for the Stevens-Duryea and the Corbin lines. The Newburg Automobile Company has taken the Lozier agency in Newburg, N. Y.

Under the supervision of Lucius S. Tyler, of the Boston office, and the local management of Melvin E. Dixon, the Maxwell company has just established a new sales agency at 84 Mechanic street, Worcester, Mass. The large salesroom

has been attractively fitted up, and an entire line of the new models is on exhibition.

### PERSONAL TRADE MENTION.

The death is announced at Amesbury, Mass., of William E. Biddle, president and treasurer of the Biddle & Smart Company, aluminum body builders.

Lee Counselman has accepted the position of sales manager with the E. R. Thomas Detroit Company. He was for seven years with the National Cash Register Company as publicity manager.

R. D. Babson has just accepted a position with the automobile department of the Whitlock Coil Pipe Company, Hartford, Conn., entering upon his new duties on the first of the year.

E. L. DeCamp, formerly connected with the New York office of the Packard Motor Car Company, has been appointed representative of Continental tire interests on the Pacific coast, with headquarters at San Francisco.

Since the first of the new year, B. C. Swinehart, vice-president of the Swinehart Clincher Tire & Rubber Company, Akron, O., has made his headquarters at the Chicago office, 1231 Michigan avenue, where he will continue to look after the western trade in the interests of his firm.

Fearing that he would never hear the end of the leap year joke if he postponed his nuptials after the first of the year, J. G. Sterling, chief engineer of the F. B. Stearns Company, Cleveland, O., who had originally planned to get married next spring, accordingly honored the final day of the old year by having the ceremony performed.

W. W. Burke, formerly manager of the New York branch of the Electric Vehicle Company, has been appointed manager of the New York branch of the Mora Motor Car Company, and will open a salesroom at the southeast corner of Broadway and Fifty-second street as soon as the premises can be made ready.

Charles H. Rockwell, who was, until recently, advertising manager for the National Cash Register Company, has been appointed assistant sales manager of the H. H. Franklin Manufacturing Company, with headquarters at Syracuse. Mr. Rockwell has had considerable experience in the automobile business, having been advertising manager with Autocar Company, and prior to that assistant sales manager of the Haynes Automobile Company, Kokomo, Ind. He will be associated with F. R. Bump, who has charge of the Franklin sales organization. H. G. Kilbourne and J. E. Sangster have been appointed manager and assistant manager, respectively, of the Franklin Automobile Company in Boston, assuming charge on the first of the year. Mr. Kilbourne is a mechanical engineer, and has had a long and varied experience as a salesman, having been associated part of the time with Mr. Sangster, who was his assistant. C. E. Wheeler, formerly in charge of the Boston, remains with the company in another capacity.

INFORMATION FOR AUTO USERS

**Ross Steering Gears.**—One of the commonest defects of the average steering gear is the fact that it wears in the straight ahead position to such an extent that when adjustments are made to compensate for this it binds at the end positions. The Ross Gear & Tool Company, Lafayette, Ind., has made a special study of this matter and as a result has brought out a new type of steering gear. It is known as the Model B.A., and a part sectional view of its essentials is shown by the accompanying illustration, Fig. 1. This steering gear is of the tubular type and has been designed

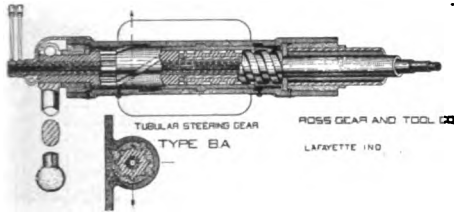

ROSS GEAR ESSENTIALS, TYPE BA.

with such a liberal amount of contact surface that the wear is not only reduced to a minimum, but is so distributed that taking up for play in the straight ahead position does not cause binding when the wheel is turned to either extreme. It is constructed to meet the demand of both touring car and truck service, in which an absolute back-lock is required. As shown by the drawing, the steering arm is given a sidewise motion. It can be put on the squared end of the shaft shown, where controls are desired through the column, or it can be made all in one piece with the shaft, which in that instance would be solid, and the controls would be put on the outside. The internal controls are op-

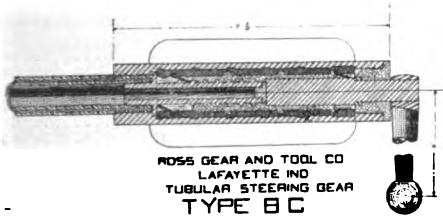

SECTIONAL VIEW OF TYPE BC.

erated by the usual small hand levers on a sector over the wheel, but which does not rotate with it. For light cars the same makers specialize their type B.C., a sectional view of which is shown by Fig. 2, and they also make other types, such as spiral and disc steering gears, beside a line of universal joints and bevel gears, the latter being planned to makers' specifications.

**A Handy Gasoline Gauge.**—Some means of readily ascertaining the amount of gasoline in the tank of a car without the aid of a dirty stick stuck in the filler opening, or a lighted match held near it, has long been desired by autoists generally. To supply this demand, the Edmund E. Hans Company, Minneapolis, Minn., has brought out the Hans gasoline gauge, which is a simple and compact instrument adapted to be placed on the dash of a car, and showing the depth in inches and fractions of the gasoline in the tank, with which it is

connected. As its name indicates, it resembles a steam gauge, the pointer, instead of recording pressure, giving the depth of the liquid in the tank. The instrument consists of a float chamber of rectangular brass tubing, of the same depth as the tank. In this tube is a copper float, while surmounting the tube is the dial, as shown by the accompanying illustration. A silk cable attached to the float passes over a drum geared to the spindle, on which the indicating needle is mounted. When installing it on a car, the instrument is placed so that the bottom of the float chamber is half an inch lower than that of the gasoline tank, connection being made from the bottom of the float chamber of the instrument to the feed line from the tank to the carbureter, by means of an ordinary brass "T." It is equally adaptable to pressure systems, as well as to many other uses. Gasoline has no effect on the special braided silk cable used, and the instrument is so simple that the makers guarantee it unconditionally for one year. They have recently opened an eastern branch office at 25 West Forty-second street, New York City, which is in charge of Howard Greene.



HANS GASOLINE GAUGE.

**Great Scott Carbureter.**—The distinctive feature of the carbureter produced by the Scott & Sons Company, Medford, Mass., is the use of two separate needles, one for low speeds and the other for high and intermediate speeds. They are represented in the illustration by *B* and *H*. The high-speed needle is made of steel, tapered and hardened, and passes through the steel bushing *I* into the gasoline passage *J*, the bushing being cupped for the purpose of retaining a priming charge to start the motor. *C* is the high-speed adjustment. *K* the air adjustment, *A* the throttle, and *L* the float adjustment. At low speeds the

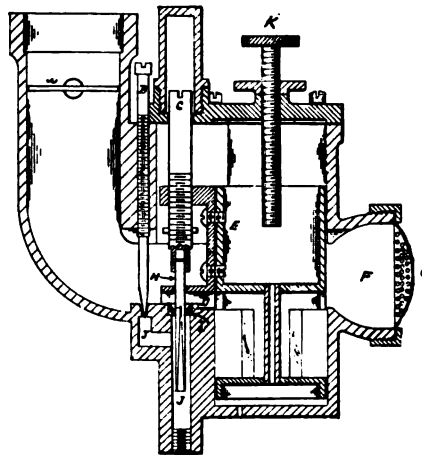

SECTION OF GREAT SCOTT CARBURETER.

passage *D* supplies all the air that is required by the motor without lifting the air valve *E*. At intermediate and high speeds this passage is not sufficient; consequently the air valve *E* is lifted by the vacuum created by the motor until sufficient air is obtained. The high-speed needle *H* be-

ing tapered and attached to the air valve *E*, this latter moves up and down with it; and as the taper of the needle is proportioned to harmonize with the area created by the lifting of the air valve, an increased volume of air is always supplied with an increased amount of gasoline. It is claimed that the Great Scott carbureter gives a perfect mixture at all speeds, that it gives more power and speed, and is economical of gasoline.

**Tools for Automobilst and Repair Man.**—Some of the most attractive lines in the wide range of tools for automobilists manufactured by the Mound Tool & Scraper Company, St. Louis, Mo., are now put up in special strongly constructed polished wood cases. Among them is a case of 20 tools, gotten up for use



MOUND SET OF 20 TOOLS.

in auto repair work, comprising various chisels, scraping tools, rivet punches, nail set and drift. Another useful line is a case of six scraping tools of assorted sizes from 6 to 10 inches, the



MOUND SET OF SCRAPING TOOLS.

scrapers being made of best tool steel, carefully forged, tempered and hollow ground. A series of carbon scrapers has been designed for removing soot from the top of a piston without taking off

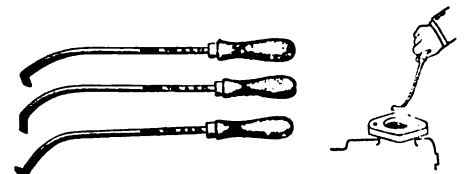

MOUND CARBON SCRAPERS.

the cylinder head. They are of 1-4 inch crucible steel, hand forged, and polished finish. Among the other articles are noticed cotter pin extractors, offset screw-drivers, improved all-metal screw-drivers, chisels, and three-quarter scrapers, all of which have been specially designed and manufactured with a view to meeting the particular requirements of the automobilist, as it is a matter of common knowledge that standard tools frequently fall far short of being what is needed to accomplish the many small repairs about an automobile.



**INDEX TO ADVERTISERS**

Acetylene Gas Illuminating Co. 59	De Luxe Motor Car Co. 66	Jeffery-Dewitt Co. 59	Pfanstiehl Elec. Laboratory 59
Acme Motor Car Co. 66	Diamond Chain & Mfg. Co. 59	Jeffery & Co., Thos. B. 93	Pierome Hide Co. 61
Adams Co. 66	Diamond Rubber Co. 60	Jencick Motor Mfg. Co. 62	Pierce Engine Co. 67
Add-Wear Auto Tire Sleeve Co 67	Dien. Ch. 79	Jones Speedometer 65	Piney Woods Inn. 72
Aerocar Motor Co. 66	Dietz Co., R. E. 71	K. W. Ignition Co. 70	Pioneer Brass Works 61
Ajax-Grieb Rubber Co. 67	Dixon Crucible Co., Joseph 69	Kimball Tire Case Co. 68	Pirelli & Co. 67
Am. Brass & Alum. Works. 61	Dorris Motor Car Co. 66	Kokomo Electric Co. 86	Precision Appliance Co. 63
American Locomotive Motor Car Co. cover	Dover Co., Geo. W. 57	Konigslow, Otto 61	Prest-O-Lite Co. 70
Anderson Forge & Machine Co. 61	Dow Portable Electric Co. 62	Lavalette & Co. 63	Progressive Mfg. Co. 63
Apperson Bros. Automobile Co. 82	Duplex Coil Co. 65	Lear Automobile Co., Oscar 66	Prosser & Sons, Thos. 61
Ashtabula Bow Socket Co. 65	Eastern Carbon Works 76	Leather Tire Goods Co. 67	Quinby Co., J. M. 65
Atwood Mfg. Co. cover	Echo Horn Co. 81	Lipman Mfg. Co. 58	Raines & Co. 58
Auburn Automobile Co. 86	Eclipse Machine Co. 58	Lobe Pump Co. 63	Rainier Co. 57
Audel & Co., Theo. 57	Edgar Mfg. Co. 58	Locke & Co. 75	Reeves Pulley Co. 59
Aurora Motor Works 84	Edmunds & Jones Mfg. Co. 58	Locomobile Co. of America 82	Remy Electric Co. 63
Auto Pump Co. 58	Elldredge Electric Mfg. Co. 57	Logan Construction Co. 66	Richardson Engineering Co. 59
Autocar Co. 82	Ellsworth, J. M. 94	London Auto Supply Co. 65	Robert Instrument Co. 59
Automobile Catechism 62	Elmore Mfg. Co. 89	Long Mfg. Co. 76	Roberts Motor Co. 59
Automobile Supply Co. 58	Empire Automobile Tire Co. 68	M & M Mfg. Co. 80	Robinson & Sons Co., Wm. E. 65
Automobile Utilities Co. 59	Empire Wheel Works 65	Macbeth-Evans Glass Co. 77	Rock Island Tool Co. 76
Auto-Shine Co. 63	Excelsior Supply Co. 59	McCord & Co. 68	Ross Gear & Tool Co. 61
Avery Portable Lighting Co. 73	Fairmont Engineering Works 66	Mandeville Steering Wheel Muff Co. 72	Royal Battery Co. 62
Baldwin Chain Mfg. Co. 59	Firestone Tire & Rubber Co. 67	Manhattan Electrical Sup. Co. 58	Royal Equipment Co. 63
Barnett Drop Forging Co. 74	Fisk Rubber Co. 81	Manhattan Screw & Stamping Co. 78	Rubay, Leon 74
Bay State Stamping Co. 58	Forest City Motor Car Co. 88	Manhattan Storage Co. 63	Rushmore Dynamo Works 90
Beaver Mfg. Co. 59	Fort-Pitt Motor Mfg. Co. 83	Maple City Mfg. Co. 70	Salisbury Wheel & Mfg. Co. 62
Behen-Faught Motor Car Eq. Co. 59	Franco-Am. Auto Supply Co. 58	Martini Import Co. 57	Samson Leather Tire Co. 65
Bellefontaine Auto Co. 74	Franklin Mfg. Co., H. H. 95	Mason, John A. 65	Sanford Mfg. Co., F. C. 62
Bealy & Co., C. H. 62	Fry, T. C. & W. L. 59	Masury & Son, John W. 72	Saxon Lamp Co. 62
Bethlehem Steel Co. 74	G & J Tire Co. 85	Mayo Radiator Co. 61	Shawver Co. 63
Blasier Mfg. Co., M. E. 65	Garford Motor Car Co. 66	Merchant & Evans Co. 76	Spare Motor Wheel of America 64
Blomstrom Mfg. Co. 74	Gearless Transmission Co. 82	Merritt & Co. 58	Speed Changing Pulley Co. 61
Boker & Co., H. 62	Gelszler Bros. 58	Michelin Tire Co. 67	Spicer Universal Joint Mfg. Co. 61
Borbein Auto Co. 70	General Accumulator & Battery Co. 65	Midgley Mfg. Co. 61	Spittdorf, C. F. 61
Bosch, Robert 88	Gibney & Bros., Jas. L. 63	Miller Bros. 65	Sprague Umbrella Co. 83
Boston Auto Gage Co. 69	Gilbert Mfg. Co. 71	Miller, Chas. E. 74	Springfield Metal Body Co. 65
Bowers Co., F. E. 71	Goodrich Co., B. F. cover	Mitchell Motor Car Co. 66	Standard Automatic Lub. Co. 59
Bowler & Co., S. F. 65	Gray-Hawley Mfg. Co. 77	Model Automobile Co. 66	Standard Co. 79
Boyle & Co., John 73	Grout Bros. Auto Co. 66	Moline Automobile Co. 88	Standard Roller Bearing Co. 62
Brennan Motor Co. 74	Hans, Edmund E. 84	Monarch Motor Car Co. 66	Standard Welding Co. 75
Bridgeport Vehicle Co. 70	Hardy Co., The R. E. 63	Moon Motor Car Co. 66	Stanley, John T. 64
Briscoe Mfg. Co. 59	Harris Oil Co., A. W. 62	Morgan & Wright 80	Steam Carriage Boiler Co. 58
Brown, Wm. W. 58	Hartford Rubber Works Co. cover	Mosler & Co., A. R. 59	Stearns Co., F. B. 67
Brownell Motor Co., F. A. 59	Hartford Suspension Co. 68	Moss Photo Engraving Co. 85	Stevens-Duryea Co. 79
Buckeye Jack Mfg. Co. 73	Hatfield Motor Vehicle Co. 66	Motor Car Co. 80	Stewart & Clark Mfg. Co. 68-72
Buckeye Mfg. Co. 68	Haynes Automobile Co. 59	Motor Car Equipment Co. 71	Stitch-In-Time Vulcanizer Co. 71
Buffalo Carbureter Co. 77	Healy Leather Tire Co. 67	Mots Clincher Tire & Rub. Co. 67	Stretch Machine Co., A. 68
Bullard Automatic Wrench Co. 75	Heinze Electric Co. 75	Muller, Albert 67	Studebaker Automobile Co. 80
Bullard, J. H. 67	Hercules Auto Specialty Co. 78	Mutty Co., L. J. 65	Success Auto Buggy Co. 67
Buob & Scheu 65	Hertz & Co. 65	Myers Auto Top Co. 65	Supplementary Spiral Spring 84
Cadillac Motor Car Co. 66	Hess-Bright Co. 61	National Auto Accessories Co. 59	Swinehart Clincher Tire Co. 76
Cameron Car Co. 66	Hicks Speed Indicator Co. 76	National Battery Co. 75	Thomas Motor Co., E. R. 91
Canton Drop Forge & Mfg. Co. 61	Hine-Watt Mfg. Co. 59	National Brake & Clutch Co. 69	Thompson Sons Co., J. P. 68
Central Body Co. 65	Hoffecker Co. 65	National Motor Vehicle Co. 89	Timken Roller Bearing Axle 87
Champion Co., A. 75	Hoffman, Geo. W. 58	Neustadt Auto & Sup. Co. 74	Trebert Gas Engine Co. 67
Chelsea Clock Co. cover	Holley Bros. Co. 78	Never-Miss Spark Plug Co. 62	Tucker, C. F. 53
Clark, E. S. 58	Holsman Automobile Co. 83	New Process Rawhide Co. 77	Turner Brass Works 61
Cleanola Co. 69	Hopewell Bros. 70	N. Y. Sporting Goods Co. 58	Uncas Specialty Co. 68
Coes Wrench Co. 54	Hotchkiss Mfg. Co. 61	Nordyke & Marmon Co. 66	Veeder Mfg. Co. 85
Conn. Steel & Wire Co. 65	Hotel Pierrepont 72	Norway Motor & Mfg. Co. 68	Walker Co., E. C. 68
Comptoir d'Innovations pour Automobiles 63	Hotel Richmond 72	Nuttall Co., R. D. 61	Warner Instrument Co. 86
Conn. Tel. & Elec. Co. 86	Hotel Tampa Bay 72	Ofeldt & Sons 58	Warner Pole & Top Co. 85
Conover Motor Car Co. 77	Howard Motor Works 66	Old Colony Light Co. 75	Waukesha Motor Co. 74
Continental Caoutchouc Co. 67	Hydraulic Pressed Steel Co. 61	Olds Motor Works 67	Wayne Automobile Co. 87
Continental Motor Car Co. 67	Imperial Motor Car Co. 87	Pacific Trucking & Mfg. Co. 58	Weeber Mfg. Works, C. F. 63
Continental Motor Mfg. Co. 68	Indestructible Steel Wheel Co. 61	Packard Electric Co. 62	Weed Chain Tire Grip 69
Cook's Sons, Adam 78	Index Speed Indicator Co. 63	Packard Motor Car Co. 97	Welch Motor Car Co. 80
Corbin Motor Vehicle Corp. 80	Jackson Automobile Co. 66	Palmer & Singer Mfg. Co. 67	Western Motor Co. 76
Corcoran Lamp Co. 65	Jeffery-Dewitt Co. 59	Parish & Bingham Co. 61	Weston Elec. Instrument Co. 81
Cornish-Friedburg Motor Car Correspondence School of Motor Car Practice 62	Cowles & Co. 58	Parker, Stearns & Co. 76	Wheeler & Schebler 90
	Crown Battery Co. 77	Pease & Sons, S. C. 65	White Co., The 96
	Crown Soap Co. 80	Penn. Auto Motor Co. 67	Whitney Mfg. Co. 75
	Cullman Wheel Co. 58	Perfection Grease Co. 73	Winton Motor Carriage Co. 98
		Peugeot Freres 61	Wing Co., Chas. 65
			Witherbee Igniter Co. 62
			Wyman & Gordon Co. 57
			York Motor Car Co. 87

FOR UNMATCHABLE QUALITY BUY

**COES** 91

STEEL HANDLE MODEL WRENCH 91

**THE WRENCH for Automobilists**

High-grade quality in every detail of design, material, workmanship and up-to-date improvement. Excellence with extremely reasonable cost.

NON-BREAKABLE CASTINGS  
NON-STRIPABLE THREADS  
NON-TROUBLESOME PARTS

**QUALITY**

through and through.

Look for the name—COES



70 years splendid reputation worthily maintained

right up to the present time as the World's Best Wrench Makers. Write for "Wrench Book" free.

**COES WRENCH CO.**  
WORCESTER, MASS.

# THE AUTOMOBILE



DOWN through Poitou, in mid-France, and on across the barren Landes runs the great Route d'Espagne, along which journeyed Louis XIV when he was on his way to wed the Spanish Infanta Marie-Thérèse at Saint Jean de Luz in 1660, and along which many a stirring automobile race has since been held. The last of racing or touring tests over unguarded roads was held here only last summer, when five lost their lives in the Coupe de la Presse touring competition, which degenerated into a race, and the Government stepped in and stopped it. It was the same fate which befell those of the famous Paris-Madrid race of

1903, when Gabriel's Mors, from Paris to Bordeaux, first broke the sixty-mile-an-hour record for travel by road.

As one has made his way gently or rapidly, down through that marvellously opulent region of mid-France south of the Loire, and has left Tours, Chateauroux, and Poitiers behind, a while new panorama of scenic sensations awaits him. At Libourne, thirty kilometres north of Bordeaux, he has crossed the imaginary line which limits the frontiers of the north and the south, the region of the *vins du table* and the *vins de marque*. From thence his way lies through a country entirely southern in aspect, where, if the leaves do fall from the trees once with the round of the seasons, there is a mildness of at-



mosphere and an easy manner of living very different from that which holds good in the northern parts of France.

Bordeaux is the obvious and natural stopping place on the way south, and since a wide detour has to be made just south of here, to avoid the awful granite blocks of the times of the Henris and the Louis which still project above ground for a matter of some eighty kilometers, the city may well be reckoned the actual gateway to the much vaunted Côte d'Argent.

Now almost as celebrated as the Côte d'Azur of the Riviera, this fascinating strip of Atlantic coast-line, lying under the shelter of the western Pyrenees and loping over into Spain, has a winter season of quite six months duration, and indeed what the hotel proprietors and the railway managers call an all year round clientele, for it is one of those regions where it is, relatively, warm

in winter and wuffed by refreshingly cool breezes in summer.

For the six months, from October to May, the elite of all Europe makes gay in the resorts of Biarritz and San Sebastian, and another element takes things easier in Saint Jean De Luz or Cambo.

Automobilists from afar come and go in steady streams all through the year all up and down the Côte d'Argent, over into Spain, and up into the higher valleys of the Pyrenees. There is another group of devotees which makes its headquarters at Pau, but there things are more orthodox and conventional, and there is not the brilliancy and variety of life and atmosphere that is to be had from the cosmopolitanism of Biarritz and the in-



THE APPROACH TO FONTARABIA.

prise and the other a "concession"), "the game," and all the social divertissements of a cosmopolitan whirl of humanity. Added to this are the not important attractions of nature, the sea and sky, a wonderful panoramic background of the purple Pyrenees, and a fascinating melange of men and manners.

The fame of Biarritz is of the epoch of the third Napoleonic era, when the ambitious Eugénie gave it the cachet of her favor and compelled that of her indifferent spouse. It was only, however, when the Russians, the Americans, and the English came—and the automobile, that Biarritz took on its entirely modern aspect. Finally a batch of grand dukes moved over from Cannes, and England's king put in a season here, and the young Alphonso began to vibrate—on an automobile—between here and San Sebastian and the Palace Miramir that all the world and his wife began to turn their thought to this pearl of Atlantic sea-coast resorts.

Biarritz, then, is the objective south of Bordeaux of all up-to-date automobilists, and as an itinerary for getting south the Route d'Espagne, leaving Paris by the Porte Maillot, Suresnes, Versailles, Rambouillet, Chartres, and Chateaudun is a pleasant change from that usually followed down through the Rhone valley. Incidentally, if one is bound for Monte Carlo—and

timacy of the rolling won't be headed off by counter attractions—there is a matter of billows of the Gulf of Gascony as they pile upon that strip of coast-line bight, extending from the mouth of the Gironde around the Santander in Spain, and so dreaded of sailormen.

Biarritz, in a way, is like any other great European watering place, crowded with great hotels, the inevitable Casino (two of them here, one a municipal enter-

prise and the other a "concession"), "the game," and all the social divertissements of a cosmopolitan whirl of humanity. Added to this are the not important attractions of nature, the sea and sky, a wonderful panoramic background of the purple Pyrenees, and a fascinating melange of men and manners.

The roads of the Landes are bad, and have always been bad, because there is no sufficient quantity of decent road-making material at hand to make them better. Things are improving and road-builders are learning more and more every day, though one does wonder, when he comes to think of it, if we have advanced so much over the Romans after all.

At any rate road-building was costly and difficult here in the Landes; it was even so when the Kings of Navarre paved that awful strip of road south of Bazas on the direct route to Bayonne, which remains to-day as the supreme terror of the automobilists in France.

The roads of the Landes are bad, and have always been bad, because there is no sufficient quantity of decent road-making material at hand to make them better. Things are improving and road-builders are learning more and more every day, though one does wonder, when he comes to think of it, if we have advanced so much over the Romans after all.

At any rate road-building was costly and difficult here in the Landes; it was even so when the Kings of Navarre paved that awful strip of road south of Bazas on the direct route to Bayonne, which remains to-day as the supreme terror of the automobilists in France.

**Bayonne One of France's Historic Old Towns.**

Bayonne is one of the most historic and attractive old towns of France, though it has a busy work-a-day temperament, with not a suspicion of the characteristics of Biarritz, its mondaine neighbor. The artist, the genuine vagabond tourist, and some others will like Bayonne immensely. The hotels are good, but frankly of the quality known as commercial, but they give you the real things of the country to eat and good pure wine to drink and charge you very little for it—and nothing for garaging your automobile. At Biarritz, and in all resorts, one eats imitation Parisian plats, drinks poorer wine—but with an etiquette on the bottle—and pays seventeen prices for everything. *Chacun à son goût!*

The Grand Hotel de Commerce at Bayonne, or the less expensive but better and much more picturesquely named Panier-Fleuri will do you very well, and you will eat of the famous jambon de Bayonne and wonder why you have not heard of these pork products before. The folk of Bayonne don't know how to advertise, that's all; those of Chicago do!

Biarritz is thirteen kilometers from Bayonne; its charms are many; they are all written up in the guide-books, the hotel advertisements and the railway time-tables; you go there and you take your choice of the great palace hotels, and you play the "little horses" for all you are worth—or at least more than you can afford—and you take tea on the terrace and cocktails in the American bar—which is usually presided over by a German named Heinrich, and anything else that you like that you might do so well in New York, Paris, or Vienna—all the distracting things which amuse a blaze whirl. Biarritz is an admirable centre for "something different" in automobile excursions, some of which are set forth in the accompanying sketch-map.

**In the Country of the Basques.**

One launches out on his automobile from Biarritz and within a few turns of the wheels is in the midst of the country of the Basques, a well-defined region which extends over into Spain,

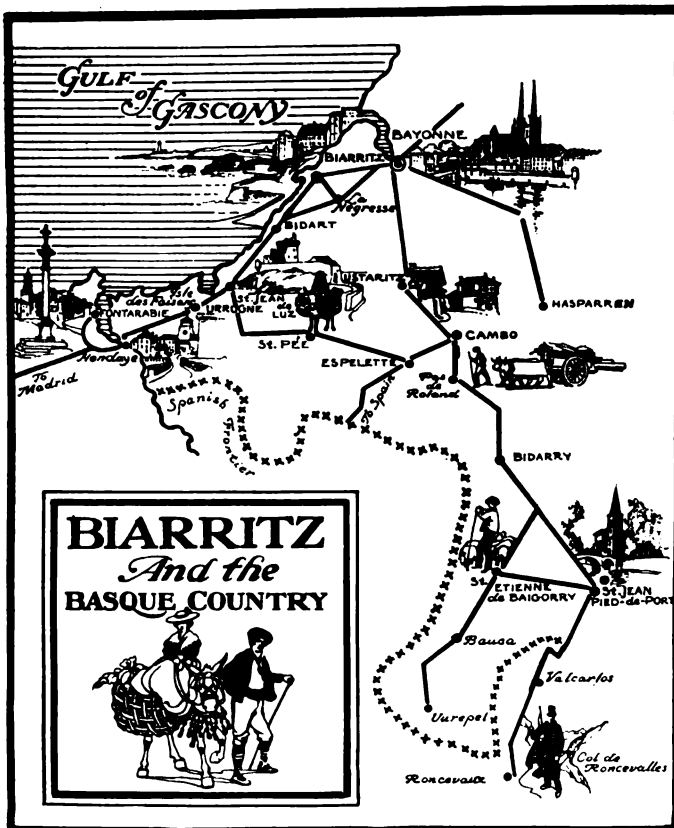

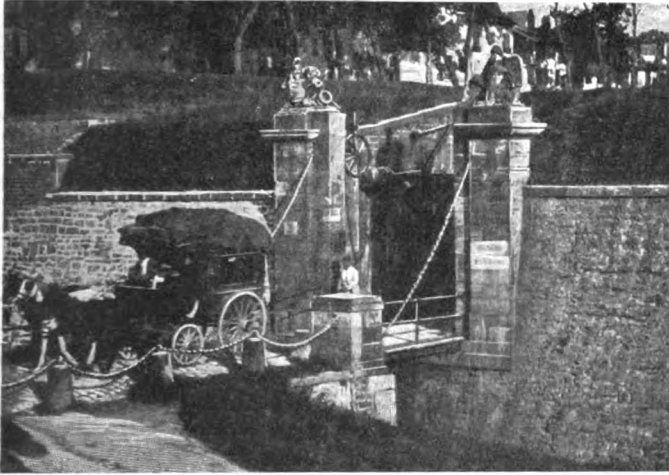

FORTIFICATION GATEWAYS OF OLD BAYONNE.

but whose people—whether in France or Spain—speak the same unique tongue, which resembles nothing else coming from the mouth of man. The *béret* of the French Basque is blue, and that of his Spanish brother red; that's the only difference; they both look as though they had stepped out of a comic-opera chorus—though the women are rather more beautiful and for the most part not so aged—and they have a cloak thrown over their shoulders and rope-soled shoes—which they call *espadrilles*—on their feet.

The Basques still obey the laws, speak the tongue, and perform the acts and rites of their ancient civilization—that which perhaps existed three thousand years gone by. In the high Pyrenees, behind their mountain ramparts, they have found the way to resist the march of progress and of many of the jealousies and crimes attendant upon an advanced civilization. A wonderful people, truly!

Leaving Biarritz, on the Route d'Espagne, within eight or ten kilometers one passes the two typical little Basque towns of Bidart and Guetary, with nothing much to remark save the severe primitiveness and cleanliness of the white-walled and red-roofed houses, the charming background panoramas, the off-shore fishing-boats, and the rolling breakers of the sea.

At Saint Jean de Luz, not more than a dozen kilometers from Biarritz, one comes upon something a good deal more characteristic of the *pays* than anything to be seen or experienced in the resort of rank and fashion left behind. The town has developed into a resort, too, of a considerable magnitude, but it has not become fashionable, and hence has some saving grace left. It was the former capital of the country of the French Basques, or at least shared that honor with Saint Jean Pied de Port farther inland. Eleanore of Guyenne brought the town as a part of her marriage dot to Henry Plantagenet in the twelfth century, and reminders of that time are not wanting in this decaying little seaport to-day. History lent a still greater luster to the little Basque metropolis when Louis XIV came here to meet and marry the Spanish princess who was to be his bride in 1660. Then came the decadence. The Basques had always been great whale fishers, and they followed the whales, which had hitherto been numerous in the home waters, to the southern seas, to the Newfoundland Banks and to all ends of the globe, when, suddenly, these hardy mariners developed a roving spirit and a desire to emigrate like the sunny Sicilians and fighting Patrick of to-day. To-day there are more Basques in the Argentine than there are in France, and they are still on the go.

#### On Towards the Spanish Frontier.

On towards the Spanish frontier another half a dozen kilometers brings one to Urrugune, famous principally because of its clock-tower and some verses which Victor Hugo wrote about it. The tower still bears the following bloodthirsty inscription,

but what the exact significance of it is no one seems to know: "Vulnerat Omnes, Ultima Necat." The town, as might be expected, is thoroughly Basque in every crazy, crooked street, and though it has three thousand inhabitants not one of them cares a jot what is happening at Paris and much less what is going on between America and Japan; indeed the only city in America of which they have ever heard is Buenos Ayres, and that only because one or another of them has a relative there.

To Hendaye and the frontier is only another *petit pas*, six or seven kilometers. Hendaye, as a matter of fact, is the railway frontier station; the frontier station by road is at Behobie, at the French end of the Pont International, where, if you are going into Spain, to Fontarabia and San Sebastian, you will have to arrange your custom formalities. These look formidable when set out on the poster tacked up in the Bureau, but they are really quite simple. If you anticipate any trouble the local garage proprietor at Behobie or Saint Jean de Luz will—for a price—relieve you of all annoyance, and may perhaps be induced to guarantee the duties if you are only going across to San Sebastian for a day or two. This is worth looking into. The name of this amiable Frenchman is Claverie, and his address is simply Behobie or Saint Jean de Luz. The Spanish government holds back six pesetas of the sum you advance for customs duties, to pay for the wear and tear on Spanish roads, but since their highways in the immediate vicinity of the frontier are as good as they are across the border no one will quarrel. The farther inland into Spain you go the worse they get, though.

Fontarabia lies four kilometers towards the coast from Irun, the first Spanish town after you have crossed the bridge. Here no one knows French—not even your kind—and is obliged himself to have an interpreter to make himself understood if he takes a ten-mile journey into France and accosts a gendarme by the way. With the indigenous Basque the case is different. A Basque living fifty miles over the border in either country talks



UNCLASSIFIED—BUT GOOD—ROAD IN THE BASQUE COUNTRY.



the same speech as his alien brother, though one knows not French nor the other Spanish. The Basques may be a dying race, but they are holding on to the remnants of their mother tongue with a remarkable pertinacity.

Irun is nothing for the tourist; Fontarabia is much. The latter is a mossy, decaying bit of medievalism living to-day and as notable an example as one will find in Europe close by a great international thoroughfare. Fontarabia is very, very unworldly. It has nine thousand inhabitants, but it doesn't look it, and most of them are dozing away in the shadow of grim-barred windowed and red-roofed Renaissance houses in utter indifference that certain progressive ones are trying to create a resort.

San Sebastian is twenty kilometers beyond Irun. It is the fashionable watering-place of Spain. One can get but little information in France concerning it, but the Spaniards themselves think that it overshadows Biarritz by far. Well, perhaps it does! One is free to take his choice. Anyway there are great hotels here, and the cuisine is French, and accordingly better than if it were Spanish, and there are fine esplanades and shady promenades and bullfights and gambling. Anything you like!

#### In the Heart of the Western Pyrenees.

Doubling back to Saint Jean de Luz and then turning sharp to the right, one follows the valley of the Nivelle as it flows down from its cradle in the upper Pyrenees. It is the very ideal of a swift-flowing little mountain river and the road is delightful from more points of view than one. All the while one is burrowing into the heart of the Western Pyrenees, the great purple curtain always at a respectable distance, but still so near that one almost feels as if he were already mountain climbing with his automobile. The road is rising all the time, but the slope is so gentle that it is almost imperceptible.

Saint Pée is the first townlet of note on this little byroad. It is thoroughly of another world and era, as is suggested by the ruins of its fifteenth century chateau, where legend has placed sorceries and crimes unspeakable as the chief events which passed within its walls. To-day the little town sleeps its time away, and not a Basque among its inhabitants but what believes that he is as his forefathers.

One of the half dozen practicable carriage roads across the Pyrenees leads into Spain nearby, and if one is so minded he can keep on to Pampelune, the old capital of Spanish Navarre, a mountain town of thirty thousand folk almost as dead as Saint Pée, but not quite. Here the *hotels* and *auberges* have become *posadas*, and the populace spends most of its waking hours in doing nothing save dancing and smoking very black tobacco twisted into slim papillotes. Pampelune is famous for its bull fights and its cathedral, with the bulk of local interest lying with the bull-ring, where the real, unadulterated, simon-pure, non-society bull fight of classic quality takes place as often as the exploiter of the plaza-toro can get an audience together.

One can make the round from Saint Pée to Pampelune and back again into France by another road to Saint Jean Pied de Port, in all perhaps sixty kilometers. The only difficulty will be the arranging of the customs duties, which will have to be done at either Saint Jean de Luz or Saint Jean Pied de Port.

Omitting this little detour into Spain, the road still continues a gentle rise and fall, via Espalette, a Basque market town, where three or four delightfully simple but excellent little hotels will cater for your hunger and fatigue.

From Espalette into the valley of the Nive, a more ambitious sister of the Nivelle, is scarce ten kilometers. One strikes the shores of the Nive at the very spot where the Paladin Roland clove a pathway in the rocky wall which barred his progress when he was fighting for Charlemagne in the eighth century. You need not believe the tale if you don't wish to, but the roads run through a cleft in the rock just the same, and the cleft was made either by the hand of man or God at some period posterior to the time when the rocks were dumped down here.

The road by the Nive continues straight on for thirty-three kilometers to Saint Jean Pied de Port, the metropolis of the

inland Basque country, and the rival of Saint Jean de Luz for political honors in times past. The contrast between the two Saint Jeans is very great. At the seaside ville there is an air of antiquity well blended with that of modernity, but at the mountain town all is medieval, even to-day. Its very name, Saint Jean Pied de Port, indicates that it was an advance post of warring times, when the frontier roads in and out of France were even more closely guarded than they are to-day.

Saint Jean Pied de Port's old houses, its frowning citadelle—still a frowning fortress ready garrisoned for anything likely to happen—and its old gates and bridges are other attractions which place the little Pyrenean town in a class quite by itself. The hotels, too, particularly the Hotel Appeteguy—which you had best write down and not try to pronounce when asking your way—being particularly so.

The classic excursion to be made from Saint Jean Pied de Port is up to the crest of the Pyrenees, to the famous Col de Roncevaux, thirty kilometers, and all up hill. It is quite worth the doing, though again there are the annoying customs formalities to be gone through, as shortly after leaving the town the highway enters upon Spanish territory. Perhaps the mechanician at Saint Jean will have a suggestion to make. Better ask him. If the thing doesn't look otherwise practical why hire a hack, which you may do for a matter of fifty francs, but be sure you make the arrangement "*tout compris*," otherwise you will have surprises sprung upon you—*every little while*.

#### Where Roland Met His Defeat.

The pass is reached—the col or port, according as to whether you ask a Frenchman or a Spaniard—at thirty kilometers, and two kilometers farther on is Roncevaux itself, revered in the memories of our school days when we had to declaim the famous Song of Roland without having the slightest idea of what it was all about, or whether its *locale* ever existed or not. This is the place; here Roland met defeat and Charlemagne's army beat a quick retreat, and all because some credulous Basques would not understand and rolled great bowlders down upon them from above.

The great convent of Roncevaux, perched high on the mountain top, has played its part, too, in the history and romance of France and Spain. After Jerusalem, Rome and Saint James of Compestello, Roncevaux comes next as a place of pious pilgrimage. It suffices to ring the bell at the great gate when a long-robed brother will put in an appearance and do the honors.

Facing north again there is that long down-hill road, thirty odd kilometers to Saint Jean Pied de Port and another thirty odd to Cambo, an incipient and altogether lovely little resort where one may take his ease and rest, and get in touch with civilization in the shape of the New York-Paris *Herald* and yellow-backed novels. Cambo is not yet spoiled, but it is getting that way. It has two thousand inhabitants, five hotels, and no end of villas and furnished apartments. This is enough to weigh down the charms of paradise. Still Cambo is really a delightful green and white little town bedded snugly on the banks of the Nive, a very clean, well-ordered little town, and not at all "rapid," nor even conventional. The Etablissement de Bains is the chief attraction and amusement—for those who can get pleasure out of bathing and talking about one's imaginary ills to the house doctor. The automobilist bathes to a purpose, but most of the frequenters of the *villes d'eau* take baths because they don't know what else to do. Actually the popular fame of Campo to-day is due to the presence of Edmond Rostand. He came after he had made his fame with the rollicking *Cyrano*, and now the crowds come to worship at the very modern literary shrine offered by his house and grounds.

Back from Cambo to Biarritz and Bayonne is only a good twenty kilometers, the sea air blowing fresh off the Bay of Biscay the while and cooling down the whole region in a way that makes it delightful at any time of the year. Yes, Biarritz is a great resort and its attractions are many, but those of the town, the plage, the great hotels or "*les jeux*," are not the greatest.

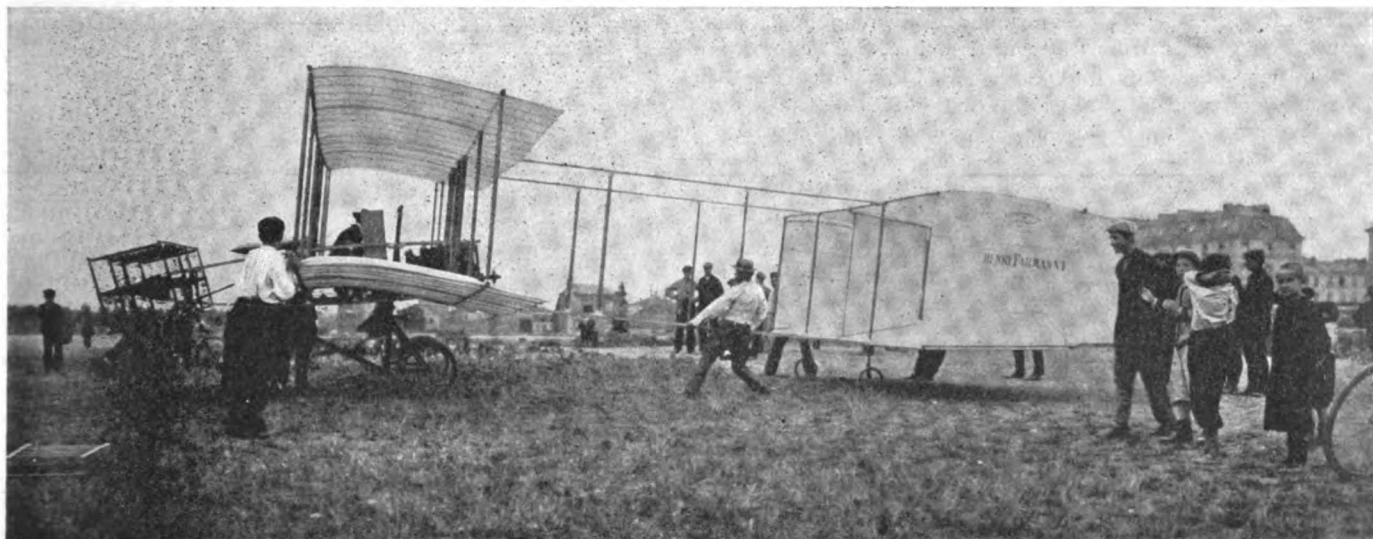

HENRY FARMAN'S AEROPLANE PREPARING FOR A PRACTICE FLIGHT AT THE ISSY-LES-MOULINEAUX DRILL GROUND NEAR PARIS.

## FARMAN WINS \$10,000 PRIZE FOR KILOMETER FLIGHT

PARIS, Jan. 13.—To Henry Farman, ex-racing cyclist and pioneer automobilist, belongs the honor of first covering a circular kilometer with a flying machine, unsustained by any gas bag, in the presence of experts and under the eyes of the public. Farman this morning won the \$10,000 prize offered in October, 1904, by Messrs. Archdeacon and Deutsch de La Meurthe for the first aeroplane covering a circle of not less than one kilometer without touching ground. His victory was clear and decisive, left not a shadow of a doubt and proved to the world that the problem of aerial navigation by machines of the heavier-than-the-air type has been satisfactorily solved.

On the Issy-les-Moulineaux drill ground, just outside the city walls, Farman made two flights on Saturday morning of so successful a nature that he officially engaged himself for the Deutsch-Archdeacon prize this morning and convoked the presence of the Aero Club committee.

At 9:30 of a clear January morning in a still atmosphere and under a sun just sufficiently warm to drive away the early mists, a course was measured out by the Aero Club officials, and preparations made for holding the world's first successful heavier-than-air flying machine contest. A score of prominent aeronauts, among them Santos-Dumont, Bleriot, Comte de la Vaulx and Kapferer had gathered on the ground to watch the attempted record flight. The public, driven off the open field by officious policemen, climbed onto the fortifications, about five hundred strong, where they obtained a better view of the proceedings than the privileged ones on the ground below.

At ten o'clock the eight-cylinder Antoinette motor was cranked, Farman mounted into his seat, and a preliminary run over the ground was commenced. When a hundred yards had been covered and the machine was going 35 miles an hour, Farman lifted the head of his aeroplane and rose gracefully

into the air, passing the starting mark at a height of 25 feet from the ground. With no other sound than the noise of the engine and the whir of the big machine. Farman rushed down the straightaway, gradually turning, then swept round the flag on an even keel and in magnificent style. As he straightened out and came down the straight stretch towards the starting point, a realization of victory came over the public and a rousing cheer went up from the crowds on the fortifications. Farman swept past the flags denoting the start and finish at a height of fifteen feet from the ground, cut out his ignition and descended gracefully almost at the feet of the little group of officials. No one asked if he had won—it was patent to all. Accounting for the curves, Farman had actually covered 1,300 meters, as subsequent measurement proved.

Kapferer, who had been holding the watch, yelled out: "One minute twenty-eight seconds," the time of the flight; then the Gallic temperament let itself loose, Farman was torn from his machine, carried in triumph, kissed on both cheeks, and cheered again and again. The only person on the ground who maintained his *sang froid* was the hero of the hour. No victory was more deserved than that of Henry Farman. Since receiving the machine built for him by the Voisin Freres, he has perseveringly and persistently trained him-

self to fly, modifying the machine where necessary, but always declaring that as much depended on the man as the apparatus.

### Severity of Kilometer Test.

PARIS, Jan. 6.—For several months fifty thousand francs in crisp bank notes have been waiting to be handed over for one minute's work in the air, without a person on the face of the globe being able to lay claim to them. Flying a kilometer in a circle, so glibly spoken of by everybody interested in aeronautics, is a more difficult problem than is generally supposed, and means far more

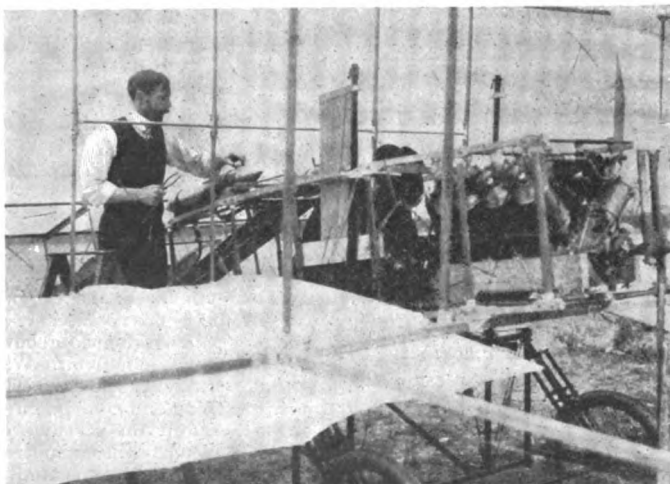

FARMAN AND HIS LIGHT WEIGHT ANTOINETTE ENGINE.

than leaving the earth and dropping down again at some point 1,093 yards from the starting line. Half a dozen machines, of as many different types, but all heavier than air, have succeeded in doing this without being entitled to special mention, much less a ten thousand dollar prize.

When M. Archdeacon's cash has been won, as it certainly will be at no very distant date, it will prove that a new and practical era in aerial locomotion has been inaugurated for the initial difficulties connected with sustentation, steering and alighting will have been solved. What the contest committee of the Aero Club of France, which has charge of the test, expects of the aeronaut is shown by the accompanying sketch. The aeronaut having been given as long a run as he desires, must leave the ground at the line *AB*, swing round the flag *C*, situated 500 meters ahead, and return to the starting point without having touched earth. Further, he must come down at the exact point from which he left the ground, or if unable to do this must drop some object in his passage which shall fall within a circle of 26 yards around that point. The starting line *AB* is not a fixed one, but a flying line, if one may use such an expression, noted by the referees called to watch the test. Likewise the flag *C* only exists after the test has been made, the aeronaut being obliged therefore to judge the distance covered before attempting to make the turn, the jury noting the point farthest away from the starting line and measuring afterwards.

The chief difficulty of the test is the turn after covering half the distance. Naturally the machines keep as close to the surface of the earth as possible, to guard against accidents, but when low there is constant danger of one of the wheels touching as the machine heels over and causing disqualification. Lack of equilibrium, too, is frequently a cause of failure, a machine which can travel successfully on the straight being incapable of being driven in a circle.

#### A \$20,000 Bet.

Increased interest in aeroplane experiments has been aroused by a bet of \$20,000 a side between Vincenzo Florio, donator of the Florio Cup, and his countryman, M. Vonwiller, who finished second to Lieutenant Lahm in the Gordon Bennett balloon contest. The one to win the prize will be the aeronaut who first succeeds in flying around the oval-shaped Palermo racing track, 1,640 yards in length.

The bet is open until the end of December, 1908; if both accomplish the feat the one who makes the best time will be the victor. It is the intention of the two bettors to employ Italian engineers only for the construction of their machines. M. Archdeacon, donator of the \$50,000 prize, has suggested that instead of taking the stakes themselves the two Italians should hand them over for the development of aeronautics, by organizing a 15-mile race for heavier-than-air machines, with a cash prize of \$20,000. He would have the race run on a closed aerial circuit, formed by two captive balloons, one kilometer apart.

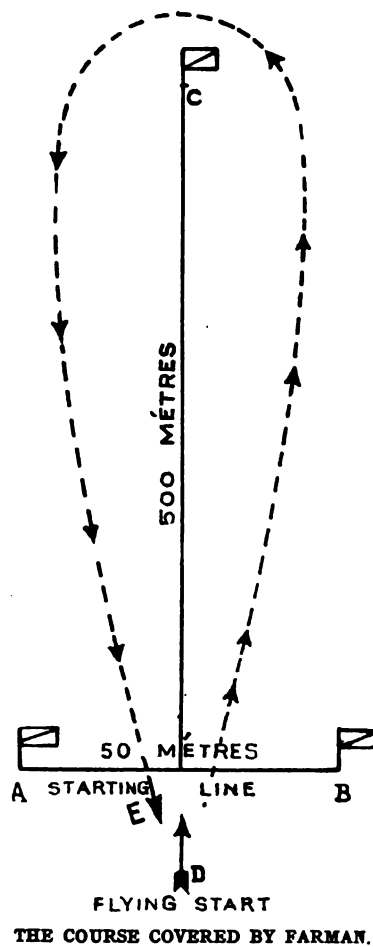

#### AFTERMATH OF QUAKER CITY ENDURANCE.

PHILADELPHIA, Jan. 13.—Since the endurance run of the Quaker City Motor Club, the honors in which were finally awarded to the White, the wearing of chips on shoulders by agency and branch managers here is quite the usual thing. Challenges are flying; the contest committee has "explained"; resignations from the Quaker City Motor Club have been sent in; even ordinary observers have invaded the columns of the local dailies to explain just why they marked the penalties on the cars to which they were assigned. All of which goes to show that in promoting any competitive affair it is the height of prudence to see that in naming the important committees an effort should be made to eliminate the trade end.

In an organization like the Quaker City Motor Club, however, where nearly all the leading lights and workers are tradesmen, such a task is decidedly difficult. A similar state of affairs probably obtains in similar organizations throughout the country. Hence the imperative need of the national body taking some part in the management of future affairs.

While the technical committee in the Quakers' run were honest and above-board, and undoubtedly handled a ticklish job with judicial calmness and fairness, the closeness of the contest gave some of the contestants a chance to insinuate that friendship for certain of the contenders had swayed their judgment. The White protests against allowing the Peerless and Studebaker to finish clean in the original contest, which were written in the heat of battle, were strongly worded, and stirred things up more. The Peerless reply kept the pot boiling. Then the Studebakers challenged after being beaten out in the final, and the Whites replied that they didn't care to accept private challenges from rivals whom they had defeated publicly. Later the Pullmanites asked the Studebakers to have it out over the course, the former claiming minor troubles in the main event put them out of it. The latter have not as yet accepted the challenge.

Some comment having been indulged in as to the inability of air-cooled cars to cover such a hard course on schedule time, President Percy Neal, of the Quaker City Automobile Company, will send a Franklin over the 172 miles of the course to-day, to-morrow, and Wednesday, and between times will keep the engine running all night in the garage.

Meanwhile many of the contestants have found crumbs of comfort in the performances of their cars, and are telling the public about them in the automobile columns. Quite a number of sales have resulted directly from these performances, and there is a general demand for other similar contests here. But it is admitted on all sides that some changes must be made in the methods of naming the committees.

The final report of the club's technical committee, based upon an examination of the cars after the run-off tie, showed a one-point penalization for the White; nine points for the Peerless, and 27 points for the Studebaker.

#### Lozier Explains About Its One-Point Penalty.

Editor THE AUTOMOBILE:

In your issue of January 9, under the table of general results showing the penalties in the Quaker City endurance run, the Lozier car is scheduled with a penalty of two points. Will you be kind enough to publish this correction, as the penalty against the Lozier in the entire run was only one point, this being caused by a momentary stalling of the engine. The rules stated that "a car shall be penalized one point for every one-minute stop," and as the motor was only stopped about ten seconds, the committee placed a penalty of only one point. With this exception the Lozier car went through the run with a perfect mechanical score, making every control, going and coming, on time.

Furthermore, the schedule contains a reference mark: "Not examined by technical committee." This also is an error, as the car passed the technical committee's examination and was declared mechanically perfect.

LOZIER MOTOR COMPANY,  
New York City. C. A. Emise, Manager Publicity Department.

# PROGRESS IN PLANS FOR BRIARCLIFF TROPHY



SKIRTING MT. KISCO—EXCELLENT GOING.



LONG, STRAIGHT STRETCH NEAR BEDFORD.



OILING THE ROADS NEAR BRIARCLIFF

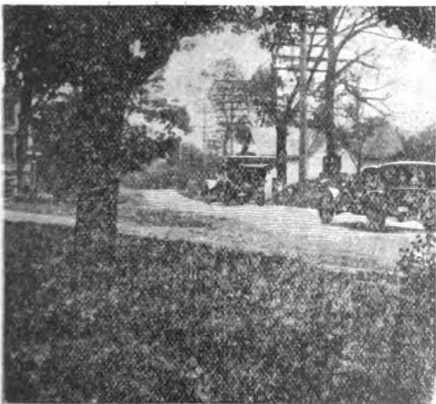

MILLWOOD, WHERE A TRAP EXISTED.

INTERVIEWED in New York City at noon on Tuesday, T. F. Moore, secretary of the committee conducting the Briarcliff Trophy race, of which Robert Lee Morrell is the chairman, supplied the following particulars on the stock chassis contest scheduled over a course in Westchester County for April 24:

"At the present moment we have twelve paid-up entries from these firms," producing a list on which was written Hol-Tan, Isotta, Lozier (2), Renault, Fiat, Stearns (3), Panhard, Allen-Kingston, Simplex. "These are in addition to the Rainier entry made by Mrs. Cuneo, for which we have received this check (the check was produced), and twelve other firms that have assured us they will make engagements. We expect to receive these entries before Wednesday night, the closing date, and they will give us Isotta, Matheson, Fiat, Garford, C. G. V., Dragon, Chadwick, Pope-Hartford, Studebaker (2), Pennsylvania and Belden.

"A special meeting will have to decide on the acceptance of Mrs. Cuneo's entry and the extension of date for receiving engagements. It is very probable that the former will be refused and the latter agreed upon, a few days' grace being accorded to allow others to put in cars.

"The rules of the race," explained Mr. Moore, "call for a \$1,000 entrance fee per car, half of which must be paid when entry is made. When all legitimate expenses have been met each entrant will have returned to him either \$500 or such proportion as remains to be distributed. When full return has been made to the entrants the balance will be distributed in the townships on the course for road improvements. We have placed our entrance fee at \$1,000 on the insistence of Mr. Morrell, to be assured of success; in other words, we have underwritten it to that amount. We are not speculating on grand stand receipts to meet expenses.

"How will the course be protected? I cannot say yet. Probably the grand stand will be on a three-mile stretch over which we have a complete right of way for each side of the road. We shall have 300 local men with power of arrest and will take into the county 900 guards, who will have to rely on moral suasion for their force, but these will be full grown men over 21 years of age, and not mere boys, as was the case on Long Island.

"Yes, there are railroad crossings on the course; there are four of them. It will be impossible to stop the train service, but as the donator of the cup and the chairman of the line are very closely connected, we shall have every facility for flagging the trains if a car is approaching. It is for this work that our three hundred guards will be principally employed."

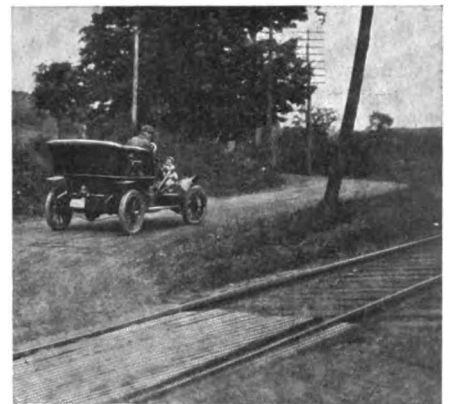

CROSSING IN LIMITS OF BRIARCLIFF.

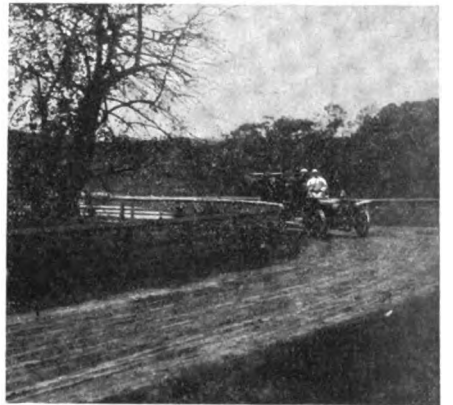

NEAR FOOT OF CROTON LAKE.

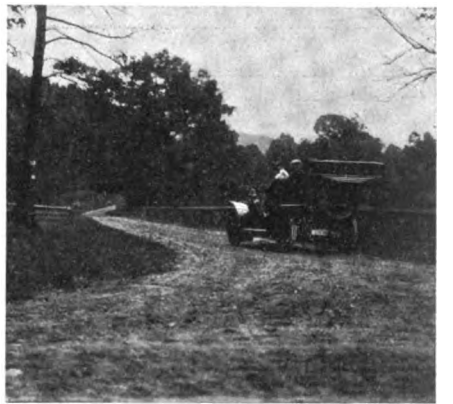

TURN TO A MILE OF BAD ROADS.



NEAR MOUNT KISCO, ANOTHER CROSSING.



## ALL TECHNICAL CONDITIONS OUT FOR THE GRAND PRIX

PARIS, Jan. 10.—Taking as a basis the international regulations adopted by all European automobile clubs at Ostend, by which a four-cylinder engine should not exceed 155 millimeters bore, Secretary A. Sautin, of the Racing Board, has now announced conditions for all classes of machines taking part in the Grand Prix, to be held early in July. Makers wishing to enter any other than four-cylinder machines are now informed exactly what conditions must be met, whether their engine be a one-lunger or an eight-cylinder. It is not likely, however, that uniformity will be broken, except possibly by one six-cylinder car, makers being of the opinion that the four-cylinder type is most suitable for racing, most of them, indeed, having their plans already well advanced for engines of this class. The official notice reads as follows:

"All cars taking part in the Grand Prix of the A. C. F. must have a four-cylinder engine of 155 millimeters bore (6.102 inches) or its equivalent in useful surface, namely, 75476.8 square millimeters. This would give:

For a single-cylinder engine.....	310 mm. bore
For a two-cylinder engine.....	219 mm. bore
For a three-cylinder engine.....	179 mm. bore
For a four-cylinder engine.....	155 mm. bore
For a six-cylinder engine.....	127 mm. bore
For an eight-cylinder engine.....	110 mm. bore

"Decimals have been excluded in arriving at these figures, and no tolerance will be allowed. Each car in full running order, but without water, gasoline, tools, spare parts, or spare tires, must weigh a minimum of 1,100 kilogrammes (2,450 pounds). Oil in the crank and gearcases will be included in this weight."

As entries at ordinary fees will close on February 15, constructors are of opinion that the choice of a circuit should be made as early as possible. Though Dieppe is a formidable candidate, it is not at all certain that last year's course will be accepted, the township being willing to offer its subsidy only on condition that there be two days' racing, and the club not being disposed to repeat the experiment of 1906. Government permission to hold the race has not yet been obtained, and, although there is little or no danger of a rebuff, Premier Clemenceau being favorably disposed towards automobile racing, most constructors refrain from sending in their engagements until all formalities have been accomplished.

The only activity of the week among racing drivers has been the formal engagement of Rigal, as driver of one of the Bayard-Clément cars. Negotiations have been opened with Gabriel, for several years a constant member of the Dietrich team, to enter the Bayard service. Le Blon is spoken of as the possible third member.

## COMPLETE ROUTE PLANNED FOR NEW YORK-PARIS RUN

THE exact route to be followed by the contestants in the 20,000-mile tour from New York to Paris has been announced by the *Paris Matin* and the *New York Times*, sponsors of the event. The journey, nine-tenths of which is on land under the power of the cars alone, and one-tenth by steamer, has been divided into three stages, as follows: (1) Across the United States to the Pacific coast; (2) through Alaska; (3) across Siberia and through Europe to Paris. Considerable changes on the route as at first announced have had to be made owing to the difficulty of traversing Alaska. The competitors will be taken by steamer from San Francisco to Seattle, where trans-shipment will be made to Valdez, no steamboat service being available direct from San Francisco to Alaska. Outside help is necessary at this stage of the journey in order to assure arrival in Alaska before the ice has broken up and the country become a huge morass.

Starting from Times Square about the middle of February, the route will be to Chicago. From this point westward exact route cannot be given, the organizers contenting themselves with naming the towns on the line of march, leaving it to the contestants to reach them as they may think best. The journey over the Rockies and the Wyoming plateau

is not expected to be as difficult in winter as it is in summer, owing to the ground being frozen hard and most of the streams frozen. If there should be heavy snow it would not be more difficult to overcome than summer mud; in fact, to San Francisco there should be comparatively little difficulty.

Arriving at Valdez, Alaska, by steamer, the tourists will penetrate into the interior until they strike the Yukon, which they will follow down to a point from which Nome can be reached. The passage across the Behring Strait will be arranged from Nome City. The landing point in Siberia will be East Cape, where an 11,350-mile run will be made.

Henry Fournier, the ex-racing driver, now Paris agent for Itala cars, announces that he is preparing an Itala for the contest, and asks permission to start it a little later than the others. It is not known who will drive the winner of the Pekin-Paris tour, for Prince Borghese has emphatically declared that he will not take part in the longer run. Two De Dions and one Motobloc are completed and will be certain starters. About a dozen others, among them three or four American cars, are declared to be starters, but there are not very strong evidences of their active preparation for such a severe ordeal.

## TARGA FLORIO TO OPEN EUROPEAN RACING

PARIS, Jan. 10.—Nine entries of three cars each from Fiat, Itala and Isotta-Fraschini have been received for the Targa Florio, the opening speed test of the European season. The race is to be held on a 250-mile circuit in Sicily, and is open to cars having a bore between 120 and 130 millimeters for four-cylinder engines, the conditions being practically the same as last year's race. The Chevalier Florio, who is almost entirely responsible for the financing of the event, refused to accept the conditions of the international conference, this race being the only one of importance in Europe on other than the Grand Prix rules.

In addition to the Targa Florio and the King of Italy's

gold medal, the winner of the race will receive \$3,000 in cash, the second \$1,600, third \$800, fourth \$400, and fifth \$200. Entrance fee is fixed at \$200 per car, the limit per firm being four cars. French firms are attracted to the race by the offer of free transportation of their racing cars and drivers from Marseilles to Palermo. Among the drivers engaged are Lancia, Nazzarro, Wagner and Minoia.

In addition to the race for the powerful cars, a voiturette speed test will be held on the same course two days before the Targa Florio, the main prize being a handsome silver trophy now held by Sizaire & Naudin. The course is an exceedingly difficult mountainous one.

# THE GYROSCOPIC ACTION OF A FLYWHEEL

By ROGER B. WHITMAN.

IT is quite usual to hear some easy reference to "gyroscopic action" during the course of an explanation of the capsize of an automobile, and it is not an uncommon superstition that the revolving flywheel is the seat of a mysterious force that will roll a car over on a turn. After a study of the subject there can be no doubting that there is reason for these beliefs, but an explanation is necessary that the general understanding of the manner in which a car can be affected by the spinning flywheel may conform to the facts. The device known as the "gyroscope" shows the effects of some of the most interesting of natural forces, and while the causes of its evolutions are by no means understood and explained, a study of its movements will

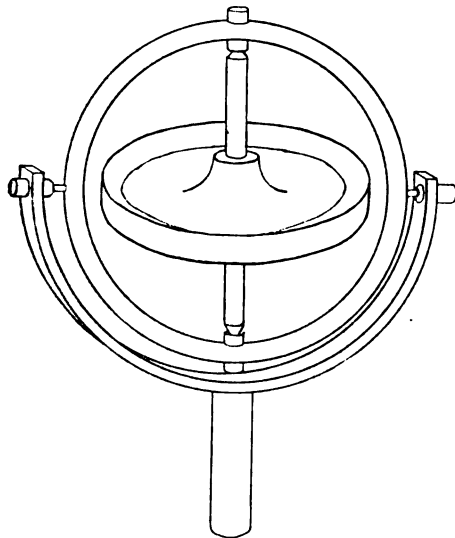

FIG. 1.—Common form of gyroscope with axis of rotation at right angles to that of spinning disk.

illuminate certain phases of the action of an automobile engine.

A gyroscope may be defined as a device intended to illustrate certain properties of spinning bodies, and the toy sold under that name consists of a ring that carries pivots at diametrically opposed points, in which revolves the axle of a heavy wheel or disk. When the disk is spinning, the toy shows a top-like tendency to stand up, or to swing around in a horizontal or inclined plane in apparent defiance of the laws of gravitation. If the ring is held in the fingers with the disk spinning, nothing unusual will be noticed until the hand is moved, when the apparatus will wriggle and twist as if attempting to escape, and will show every evidence of an opposition to the motion.

These are phenomena that are to be explained, but the construction of the gyroscope does not permit of the extended study that is possible when the ring is pivoted to a frame, the axis of rotation given to it being at right angles to that of the spinning disk (See Fig. 1). This frame is not difficult to construct, and the only precaution to take is to have the ring in balance on its pivots. When the disk is set in rapid rotation, and the frame held firmly in the hand, the axis of the disk may be pointing in any direction, but if the holder swings his arm so that the gyroscope is moved in a curved path in a horizontal plane, the ring will move on its pivots so that the axis of the disk becomes vertical. If the arm is swung at the side so that the curved path of the gyroscope is in a vertical plane, the ring will swing to permit the axis of the disk to lie horizontally.

Further experiment and observation will show that when the gyroscope is moved in a curved path, the axis of the spinning disk will tend to assume a position at right angles to the plane in which the curved path lies. Any rotation in a horizontal plane is rotation about a vertical axis, and rotation in a vertical plane is about a horizontal axis. The rule deduced from the action of the gyroscope may therefore be expressed in other terms, viz., the axis of the

spinning disk tends to set itself parallel to the axis of the greater circle in which it is moved.

This property of the gyroscope, as brought out in these experiments, is accompanied by a phenomenon that is even more striking and difficult of explanation, which is the tendency of the ring to invert itself on its pivots. If, when the disk, as seen from above, is revolving anti-clockwise, the gyroscope is moved from left to right, or clockwise, the ring will invert itself in its pivots, so that the side of the disk that then comes uppermost is revolving clockwise. The movement of the gyroscope in the opposite direction will be accompanied by the instant upsetting of the ring, so that the direction of the disk as seen from above again becomes anti-clockwise, to correspond with the movement of the hand. From further trials a second rule governing the action of the gyroscope will be deduced, that the direction of rotation of the disk tends to be the same as that of the greater circle in which the gyroscope is being moved (See Fig. 2). If the frame is removed and the same experiments performed with the ring held in the fingers, the tendency to follow these laws of the gyroscope will be evidenced by the apparent endeavors of the ring to escape from the grasp, and the wriggle and twist that will now be understood as indicative of the struggle of the disk against the restraining fingers to set its axis parallel to the axis of the greater circle, and to have uppermost the face that revolves in the same direction.

The struggle of a restrained gyroscope to follow its laws will have a tendency to keep the restraining structure from the change in position that would alter the direction of its axis of rotation. This is taken advantage of in the apparatus for checking the rolling of a ship in a seaway, the heavy disk spinning at high speed being placed with its axis vertical. The gyroscope by its weight and speed tends to remain with its axis vertical, and opposes any force that tends to alter this position. The ship is thus the object of opposing forces, of which one, the gyroscope, tends to hold it upright, while the other, the pressure of the waves, tends to roll it over. The gyroscope being the stronger of the two, the rolling motion that would alter the position of its axis is suppressed. As the axis of the gyroscope is vertical, and as the turning of the ship in response to its helm is rotation in a

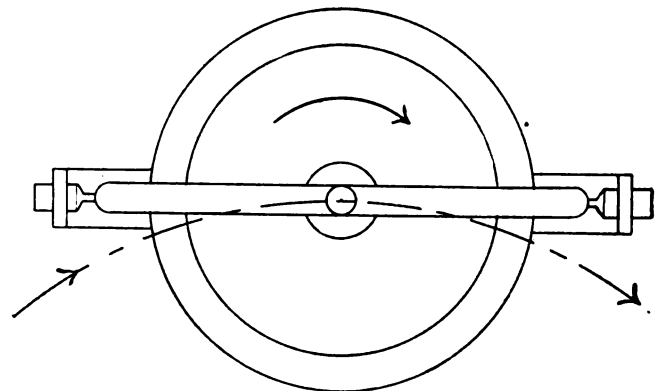

FIG. 2.—Showing direction of rotation of disk tends to that of the greater circle in which gyroscope is being moved.

horizontal plane and about a vertical axis, there is no opposition to a change in the course.

Gyroscopic action is not confined to laboratory apparatus, for it is exhibited by every spinning body, and its effects are shown in boys' tops as well as in the march of the planets about the sun. The flywheel of an automobile engine, being a spinning body, may therefore be expected to exhibit gyro-

scopic tendencies, and that it does so is amply proved by the condition of the flywheel bearing after a few thousand miles' running. It is well understood that this bearing is the first to give out, and it is the usual practice to make it longer than the others in order to render the wear uniform. While there are many causes for the rapid wear of this bearing, a study of the conditions will indicate that gyroscopic action plays a much greater part than is usually supposed. If the comparatively slow rotation of its three-ounce disk can make it practically impossible to move the toy gyroscope with a steady motion, and to prevent jerking, it is only to be expected that a heavy flywheel revolving at high speed will have its effects on the parts that are designed to hold it rigidly in position.

In the most usual construction, the axis of the flywheel is horizontal and longitudinal. A car making a turn moves in a horizontal plane about a vertical axis, which results in the immediate endeavor of the flywheel to place its axis in a vertical position. That it is unable to accomplish this is due to the construction, the flywheel bearing being the chief factor in its restraint. In going from a down to an up grade the car will move in a vertical plane about a horizontal axis, and the flywheel will then endeavor to assume a position in which its axis would be parallel to the axis of the greater circle, a tendency that would result in twisting the crankshaft into a transverse position. Every change in the direction of the car thus results in a strain on the flywheel bearing that is directly due to the endeavors of the flywheel to set the crankshaft on end or to twist it across the car.

The force with which a gyroscope acts increases with the weight of the spinning disk and with its speed, but the greatest effect accompanies the most abrupt effort to alter the position of its axis. Under normal conditions, the weight of the car is sufficient to hold the flywheel bearing to its work of restraining the gyroscopic inclinations of the flywheel, and there is no further effect than the wear. When a car takes a corner at high speed, however, the tendency of the flywheel to up-end the crankshaft will result in a tendency to up-end the car, and the cumulative effect may well be greater than the weight can hold in check. As speed is further increased there will be a critical point at which weight will be overcome, and the gyroscopic action as master of the situation will raise one end or the other of the frame to such an extent that either driving or steering wheels will lose traction. Whether it is the front or rear wheels that will be affected will depend on the direction of the curve and the direction of rotation of the flywheel, for the tendency of the latter will always be to bring uppermost the face that rotates in the direction of the greater circle.

Attempts to explain accidents to racing cars while rounding turns are often based on the assumption that the gyro-

scopic tendency of the flywheel will be to roll the car over, but that this is not the case may be deduced from the fact that a car rolling over sideways will be rotating in a vertical plane and about a horizontal axis, and that as the axis of rotation of the flywheel is horizontal, it will remain in its position rather than tend to change it. The real effect is a tendency for the car to lose its grip on the road, and this will be equally disastrous whether it occurs with the front or the rear wheels. Decreasing the weight on the front wheels will result in the loss of control of direction at a time when steering ability is most necessary, while if the power of the engine is applied against maximum traction at the rear wheels, and the traction is suddenly reduced, the engine will race and the speed of the driving wheels increase. The restoration of traction as the car strikes the tangent will give all of the essentials of a skid, and under such conditions the loss of a tire, which will most clearly be an effect, will be blamed as the cause.

Here, then, is where the danger from gyroscopic action of the flywheel is to be found. The obvious methods of averting it are to keep the speed of the car on curves below the critical point at which the gyroscopic action becomes so great that the weight of the car cannot restrain it, or to take turns in the road with as flat a curve as possible, in order that there may not be too abrupt a change in the direction of the axis of the flywheel. It would of course be possible to nullify the action by gearing in a second flywheel of equal size and weight, but revolving in the opposite direction. Such a construction would reduce the danger of skidding on turns, and in enabling racing drivers to make time on curves instead of losing it would make the additional weight a matter of little consequence, though the action of centrifugal force on the car as a whole also imposes a speed limit on curves that cannot be neglected.

To the reader whose unfamiliarity with gyroscopic action makes him skeptical of this force with which the spinning flywheel is credited, a few minutes of experimenting with a toy gyroscope will be enlightening. A more convincing test is to hold a wheel of any sort, but preferably a bicycle wheel, by the axle close to the hubs, and to try to invert it while it is spinning. As further evidence may be cited the recorded tests of a German torpedo boat one hundred and sixteen feet long and of fifty-six tons displacement, held level in a heavy seaway by an eleven hundred pound disk spinning sixteen hundred revolutions a minute.

While the gyroscope is one of the least-understood of mechanical devices, what is known of it presents undeniable evidence that tire blow-outs, defective steering gears, and other defects claimed to be the causes of automobile accidents, were not always such, but, together with the accidents, the effects of this property of a spinning flywheel.

## REGARDING SOME DEFECTS OF TOOTHED GEARS

At a recent meeting of the Royal Automobile Club, F. Humphris, the inventor of a gear of the pin and face-plate type, read a paper entitled "Tooth Gears and Gearing." Among other things, Mr. Humphris said that little had been done to determine the efficiency of toothed gearing, and that, in his opinion, the toothed gear was the most imperfect motion employed on the automobile. Considering the grinding and purring of two gears in engagement, could the designer say that it was the system which allowed the wheel to exist, or must he not admit what a clever man the metallurgist was to have provided a material that would stand this barbarous treatment? If the motion of the teeth of two gear wheels when engaging were entirely confined to a rolling character, their life would be practically

indefinite. To improve upon the present system would necessitate making a gear the teeth of which did less sliding upon one another, with a surface contact of greater dimensions, greater strength, less weight, reduction in the number of engagements for the work done, and teeth which, in addition to all these qualifications, will not change in form through wear, thus destroying the curves necessary to their perfect engagement. This could only be done by making the true toothed curves in sympathy with the mating member on which they engaged. The tooth to which Mr. Humphris referred was circular in cross section with a hemispherical end, engaging in a plate having circular holes and driven at right angles from the propelling shaft. Tests showed a very small loss of power in transmission.

# AN INTERESTING CHAPTER FROM THE PAST\*

By POL RAVIGNEAUX.

**D**AIMLER is an investigator who has transmitted to posterity the most prolific collection of patents concerning the internal combustion motor and the automobile. From the first, these patents were all taken out by Daimler in his own name, but since 1890 there are found interspersed among them the patents of the Daimler Motoren Gessellschaft and those of

his daily trials, finally succeeded, about the beginning of 1891, in realizing a dream that he had long cherished, that of making without a stop the trip from Ivry to the Point au Jour and return, a distance of about twelve miles. That date marks the origin of the success of the old French house, the investigations of which are so closely related to the researches of Daimler that it is difficult to separate them in giving credit for the results.

It was not until 1893 that Daimler, aided by his engineer, Maybach, succeeded in running the first Mercedes automobile on the road. It may be said here in passing that in order to avoid confusion I have limited my researches regarding the achievements of our predecessors to those prior to and including the year 1895, for about that time so many ideas were being tried out that it would be a most difficult thing to establish their paternity.

The first incursion of Daimler into the internal combustion motor field did not appear to be inspired by a desire for simplicity, for in a patent taken out in 1875 he describes a complicated mechanism covering an idea which Lenoir had investigated and abandoned, that of relieving the piston and connecting rod of the shock of the explosion in an atmospheric motor. To accomplish this, Lenoir placed an extremely heavy piston in a vertical cylinder, so arranged that the explosion lifted the heavy piston, which in its descent was depended upon to perform the work. Daimler added to the ordinary piston in a horizontal cylinder a couple of loose pistons placed at an invariable distance apart and situated on either side of the ordinary piston. The energy of the explosion set these two in motion, and the vacuum set up by the cooling drew after it the motor piston. As was the case with Lenoir, Daimler was on the wrong track, but the latter followed it out until it materialized in the shape of an impractical, delicate and costly machine.

Under this first Daimler patent the piston was cooled by a circulation of water through the connecting rod as is the case to-day in many large stationary motors. The speed of the motor was regulated by a governor on the admission, a valve being placed on the inlet and controlled by the part *d*, shown in the illustration, Fig. 1, which the governor caused to rise or drop, in such a manner that at a certain speed it moved a plate which completely closed the opening. The carbureter was warmed by the water circulation. Referring to the illustration, Fig. 1, the valve *c* could close the inlet pipe when lowered by *gh*, this taking place when the balls of the governor were spread by centrifugal force, otherwise the hook *e* missed *gh*.

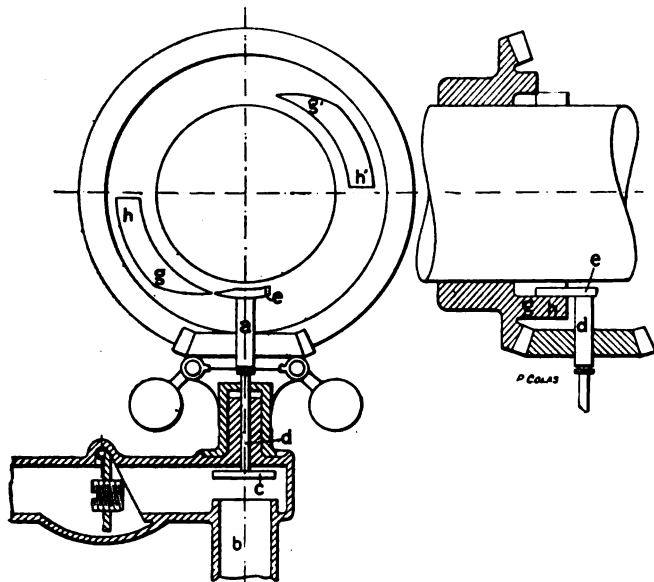

FIG. 1.—Governor of Daimler's first motor, patented in 1875.

*Daimler et Vve. Levassor*, as the patents taken out by Daimler and his French collaborator were termed after M. Levassor's death in 1895. After a time the house of Panhard & Levassor took out some patents in its own name, which we mention later on, in view of the commercial relations which united Daimler with that firm. A short *résumé* of Daimler's career may be apropos here, though it is not the intention to go into detail, a full account of his life being found in *L'Histoire de l'Automobile*, by Pierre Souvestre. He was born in 1834 and died in 1900. It was not until 1863 that he realized his own powers of initiative, after having had a long conversation with Otto. The latter had been interested in commercial pursuits, but had given them up on learning of the work of Lenoir, devoting himself to the development of the gas engine.

Daimler was subsequently employed in a German arms factory and later in an English locomotive works, in the meantime doing what he could, but he matured his plans thoroughly before proceeding, as it was not until 1875 that he took out his first patent. A little later he established relations with M. Sarrazin, the representative in Paris of the house of Otto & Langen, which later turned over to M. Levassor of the firm of Panhard & Levassor the task of executing his plans for a motor. Mme. Sarrazin later became Mme. Levassor and in this way the house of Panhard & Levassor acquired a license to manufacture under the Daimler patents, as the sole French rights had been granted to Sarrazin shortly before his death, and they descended to his widow.

Daimler had exhibited in 1889 at Paris a gasoline motorboat—this being the principal use which he predicted for his motor—a quadricycle and a miniature tramway, which was shown in operation at the Exposition. He continued his labors at Canstatt, Panhard & Levassor meanwhile working independently. Levassor, after eighteen months of discouraging set-backs during

\*Translated from "La Vie Automobile" by Charles B. Hayward.

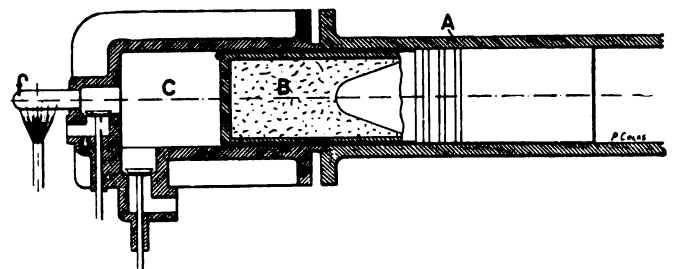

FIG. 2.—Section of early Daimler, showing tube ignition, patented in 1884.

The last-named part was duplicated because the motor described under this patent of Daimler's was of the two-cycle type.

In 1882 Daimler took out a patent on an inverted cone clutch, and in 1884 he attacked the problem of ignition, believing in the permanent success of burners and platinum tubes, which supplanted the slide valve and pocketed flame, and which battled a long while with the electric ignition introduced by Lenoir, using



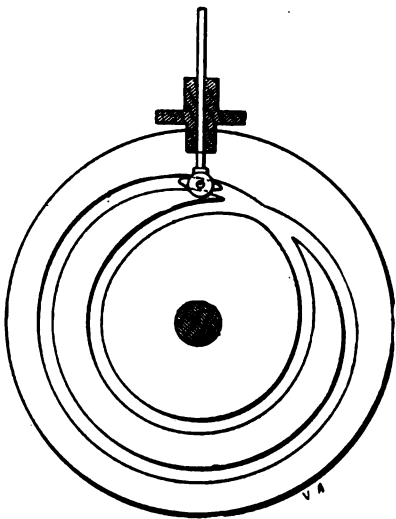

FIG. 3.—The predecessor of the exhaust valve cam and customary turning gears.

without the necessity of obtaining a new cylinder head—a piece on which a great deal of work was expended. Ignition by tube, however, was only provided as a means of starting, as Daimler depended on automatic ignition once the motor was under way. Spreading the piston rings some distance apart in order to permit of lubricating them properly was a logical sequence, and constituted an invention on which a number of patents were taken out. In the illustration, Fig. 2, the piston is shown filled at its upper end with *calorifuge*, and the diameter of the piston was reduced at this point, in order to prevent the burning of the oil, as the motor was designed to run on automatic ignition, except when starting, for which the incandescent tube was utilized. The cylinder is represented by *A*, the *calorifuge*, which consisted of slag or cinders, by *B*, and the cylinder head by *C*, while *f* is the hot tube for starting. This patent was granted in January, 1884, while that shown in Fig. 1 was issued in March, 1875. There is also one taken out in 1884 for a fan in the flywheel and an air-jacket as shown in Fig. 4.

The surface of the cylinder head is reduced to a minimum in order to diminish the waste of heat through the walls, something which worried Daimler not a little, while both the valves are placed above the piston. The exhaust is operated by a curved piece, *M*, Fig. 4, terminating in a hook at its lower end. This hook engaged with a similar one on the upper end of the vertical rod *K*, which at its other end carried a roller held in a groove, forming two concentric circles, Fig. 3, thus avoiding the use of a timing gear and secondary shaft. Regulation was affected entirely by the exhaust, a piece carried on the small exterior flywheel acting as a governor and causing the piece *o* to turn so that it missed the valve rod and the valve remained closed. Starting was aided by a compression release.

It was in 1885 that Daimler inaugurated one of the two principal characteristics of his motors; the first related to the functioning of the cycle and the second to the constructional disposition of the cylinders in the shape of a V. His chief idea was that of obtaining the maximum efficiency, as is illustrated by the following quotation from the patent just referred to.

"The new motor which I am about to describe has for its principal advantage the ability to operate at an almost unlimited speed (even up to 1,000 r.p.m.); it weighs very little and takes but little space; its power proportionate to its volume is greatly superior to what can be obtained under any of the present systems, and the importance of this invention for propelling aeronautical machines, torpedo boats, etc., is conceded."

But Daimler looked far ahead and saw clearly. Working according to well-formulated ideas, he had reduced the cylinder wall surface to a minimum, raised the compression and employed automatic ignition, but this did not suffice. In order to

batteries, and with that of Forrester, employing a magneto. Daimler's design is reproduced herewith. See Fig. 2. There will be noted in this the ingenious fashion in which Daimler disposed the motor in order to cool the piston. The cylinder head was cooled by a flange, but this did not reach down as far as that part of the cylinder against which the piston rings bore; these were placed much further down on an extremely long piston. This permitted of replacing the cylinder

simplify things he went back to the lateral arrangement of the valves, but he achieved in other ways more than he lost by this. Before describing the cycle it may be well to study the accompanying sectional view of the single-cylinder motor of the enclosed flywheel type. Are not the splash lubrication, the flywheel assemblage by taper and screw and the disposition of the valves, prototypes of present-day practice? Daimler wished to introduce into the cylinder a supplementary charge of carbureted mixture, or of air, by means of a pump constituted by the crankcase of the motor itself, and, as is the case in a great many two-cycle motors to-day, this was accomplished by placing a valve centrally in the head of the piston. This was at once an automatic and a timed valve.

At the beginning of the exhaust stroke when the piston had arrived at the end of its downward stroke a circular piece, *F*, raising the inlet valve a short time after the exhaust valve opened, the gases which had been drawn through the automatic inlet valve, *T*, placed at the side of the crankcase had by then been strongly compressed in the latter, and, entering the cylinder violently blew out the burnt gases. Until the piston had traveled a certain distance on the upward stroke, this valve remained open and the exhaust continued, so that when the exhaust valve closed it will be seen that the amount of burnt gases remaining in the cylinder must have been very small, and the two did not mix as the cold gas introduced through the piston assumed a stratified form in the lower part of the cylinder. In re-descending, the piston compressed the gases beneath it to a certain point, and then the piston valve reopened and remained open up to the beginning of the compression stroke.

Unfortunately, we do not possess comparative figures showing the power of these two motors, from which a conclusion regarding the utility of this complication could be drawn. Daimler's chief object was to produce a motor of the maximum power which should be the quintessence of lightness, and we should not overlook the fact that it is due to that lightness of the explosion motor that the automobile is possible. To-day, if it were possible to obtain greater power from a motor by adding Daimler's valve, it would not be done by reason of its complication and fear of breakage, and because the extra power thus obtainable is not a great necessity. We are well enough served without it, but in 1885 it was necessary to make arrows out of any wood; the power output of those days was not that of the present. It is not astonishing, in view of this, that Daimler should have sacrificed simplicity to attain this end. This brings Daimler down to the time when he became an autoist.

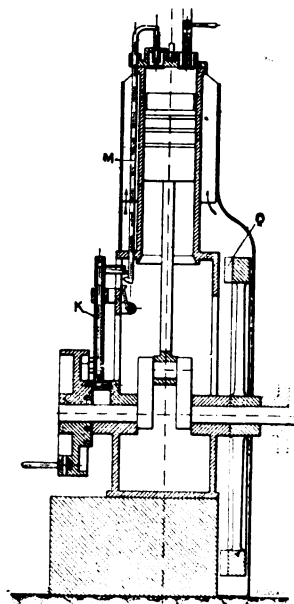

FIG. 4.—Daimler motor with air-jacket cooling and valves in the head.

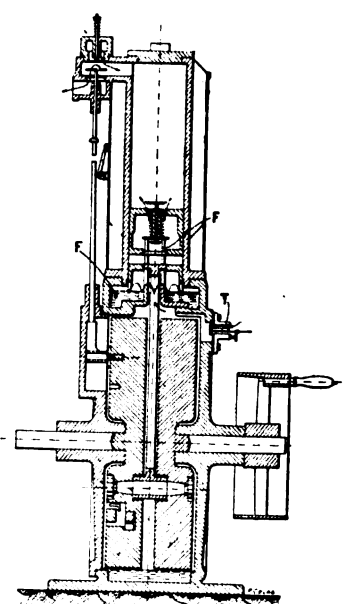

FIG. 5.—Inclosed flywheel type with valve in piston, patented in 1885.

# A STORY OF THE CRY OF "GET A HORSE"

BY A. V. A. MCHARG, EDGEWATER, N. J.

**T**O the funny side of automobiling I want to add my own little story of pioneer effort in the whiz-wagon industry. It was just after Alexander Winton had made his trip from Buffalo to New York in a gasoline wagon of his own design that my ambition to produce a self-moving vehicle became uncontrollable. Reasoning that if one horse pulled a wagon satisfactorily a one-horsepower motor should be able to do as much, I soon came across in our local papers an "ad" of a small farm motor of just the desired power—and many other wonderful qualities to boot. I lost no time in arguing my young wife into the belief that an expenditure of sixty dollars toward a motor wagon would be fully repaid by our increased social prominence—and the motor was duly purchased.

I had never seen a gasoline motor, nor had any member of the family, and so it was with fear and trembling that the last connections were made and about a pint of "that stuff they clean gloves with" was emptied into the tank. The electric switch was turned on, and, cautiously, the flywheel was turned according to directions, with no results. The family courage began to rise and they gathered more confidently around the little marvel. Suddenly there was a spit and a flash, then a roll of musketry as the little marvel became a little devil, and straightway there was a sincere effort on the part of the family to leave me alone in my researches.

## How I Conceived the Idea of Building an Auto.

After several evenings spent in running the little motor—and also in finding out why it wouldn't run—I decided to get to work on designing and building the wagon that should contain this remarkable source of power that was guaranteed to run a farm, milk the chickens and churn the eggs. I lost a whole week and two fairly good bicycles trying to adapt their running gear to my needs, without success. So I sent for some wire wheel catalogs, and finally ordered four steel rims and a sufficient number of spokes. The hubs were made of brass, with flanges for the spokes and a hole for one-inch cold-rolled steel axles. Here I was confronted by a new problem: I had to build and house this vehicle in the kitchen of our dwelling, and the only means of egress was a three-foot-six window opening on the street level, consequently I was limited to 3 feet 5 inches for the width of my wagon.

## A Machine That Was Fearfully and Wonderfully Made.

After much thought the wagon was built on the "buckboard principle:" two oak planks about five feet long, one inch thick and ten inches wide were bolted to two battens at the ends. The rear axle turned in brass bearings bolted to the planks, while the front axle swiveled on a king bolt and was controlled by a steering post and handle that projected up through the planks. The motor was firmly set amidships and bolted down to the plank frame. The crankshaft projected out on the left hand side. On this shaft was keyed a four-inch pulley, carrying a two-inch belt that drove an eight-inch pulley on a countershaft. On this countershaft was keyed a two-inch gear meshing with a ten-inch gear keyed to the rear axle. The driving belt was loose and only drove when an idler was forced into position by a lever at the "chauffeur's" right. There was no provision for reversing, it being forward only that we hoped to go. After the cooling tank and the gasoline tank were placed, a wagon box and seat were built around the machinery. True the family and a few intimate friends admitted confidentially to me that there was a confounded resemblance to a dog house about the thing, but I excused that on the ground that

they could not keep pace with my marvelous originality.

Well! one starlight night in November the last bolt was tightened; the last bit of paint was dry, and, after a hurried evening meal, we filled the tanks with water and "glove cleaner" and took the sash out of the basement window.

We rolled this marvelous creation out by the curb, and the crowd soon began to collect and the comments to fly: "What are you going to keep in it?" "Whose dog have you got in there?" "Which way will it run if it goes?" etc. Spurning all remarks, I threw on my electric switch, opened my gasoline valve, and, thanks to a merciful providence, the motor started at once; whereupon I cast a compassionate glance at the startled crowd, for as yet a muffler was unknown to me and the noise seemed to indicate power, so I liked it.

## First Trial Was an Event in Local History.

Inviting my wife to take the seat of honor at my left, I jumped to the operator's seat, and with a trembling hand pushed the starting lever into position; slowly, slowly, she started and slowly she continued to move, in fact, that was her maximum speed, and to the great joy of the crowd they were able to keep alongside of us at an easy gait and resume their study of the situation and compose remarks calculated to establish their reputations as humorists. We finally—I say finally—reached one of the principal streets, and by that time had accumulated quite a following, sufficient in fact to arouse the curiosity of a police officer who came toward us on the double quick to investigate the riot that was rapidly assuming such serious proportions. At first he was nonplussed, then, making one of those quick decisions for which the law is famous, he decided to grant us his protection, and informed us that as long as we stayed on his beat we could get a square deal. So he nonchalantly swung his club, walked alongside, and kept up a running fire of conversation, which was eventually interrupted by my running up a slight grade ending in car tracks.

## Sad Ending of an Experimental Career Well Begun.

There we stuck, and, try as I would, I could not keep that belt from slipping. To add to the embarrassment of the situation a trolley car appeared, but in spite of the interest we created the motorman refused to tie up the line indefinitely. So with the help of the officer the devil wagon was backed off the tracks against its will and down the grade where we managed to turn around and get under way on our homeward journey. All went well, though slowly, until within a block of our house, there she stopped, and stopped for good. No amount of engineering skill, no amount of outside advice availed to produce further action; so upon that spot, covered with ignominy and oil, I was at last compelled to solicit assistance and push the blamed thing home, in through the kitchen window, put up the shutters and quit for the night, amidst cries—uttered for the first time on earth I believe—"Get a horse!" "Get a horse!"

So ended my first attempt to be an automobilist. I afterwards located the fault in my motor, but never succeeded in making the vehicle go faster than a walk or up an incline greater than two per cent. I finally sold my motor to a farmer, where it apparently felt more at home, for, so far as I know, it is running yet and giving complete satisfaction.

British Board of Trade reports for the month of November, 1907, show the number of cars imported into Great Britain was 409, and for the corresponding month in 1905 and 1906 was 352 and 359, respectively.



PRAIRIE SCHOONER FORMERLY USED BY LIEUT. GIMPERLING.

### HOW THE AUTO AIDS UNCLE SAM.

Lieutenant Gimperling, 21st Infantry, U. S. A., evidently does not place overmuch stock in the saying that nothing can take the place of the army mule for getting there, for, having been detailed by General Thomas, commanding the department of Colorado, to make a progressive military map of southern Arizona, he has decided to do it in an automobile and has selected a Stoddard-Dayton in place of the time-honored covered army wagon. Instead of averaging twenty to twenty-five miles a day, the survey will proceed at that rate *per hour*. The party consists of the lieutenant in charge, H. M. Westcott, and Arthur Harris, the driver, and they left Denver recently en route for Fort Huachuca, Ariz., a preliminary thousand-mile trip which has to be undertaken in order to reach the scene of their labors. The route there lies via Pueblo and then along the old Santa Fé trail through New Mexico and Arizona, their objective point being located in the south central part of Arizona, to reach which it will be necessary to travel through country of a nature that has done much toward earning the army mule his reputation of being able to get there, for prior to the advent of the automobile the mule and the broncho were the only animals of transport sufficiently hardy to be able to withstand the rigors of such work as it entails.

There a detail of troopers and a mess-wagon will be assigned them as the work, which consists of making a topographical map of southern Arizona, will require several months for its completion. The Stoddard-Dayton car employed is not the property of the army, but is owned by Mr. Westcott. It will be used for the entire trip, and as it is the first time that an automobile has ever been employed for the purpose, the outcome will be watched with interest, particularly by General Thomas, who granted its use.



LIEUT. GIMPERLING IN STODDARD DAYTON ON THE WAY.

### A COPPER TUBE CENTRIFUGAL RADIATOR.

A distinct departure from the types of honeycomb and tubular radiators, which form the two main classes of appliances for cooling the water of an automobile engine, has been produced by the firm of Goudard & Mennesson and was offered for public inspection for the first time at the recent Paris exhibition.

The G. & M. consists of a mass of copper tubes forming a circle three or four inches in depth and about four inches from front to rear, united at opposite points by a couple of collectors forming inlet and outlet. An idea of the general arrangement can be obtained from the illustration, reproduced from *L'Automobile*. To allow of the free passage of air the tubes are separated from one another by the two ribbed frames shown at left and right of the cut.



COPPER TUBE CIRCULAR RADIATOR.

Within the circle a powerful centrifugal ventilator is mounted, the steel plate at the rear and radiating arms in front affording a bearing for this.

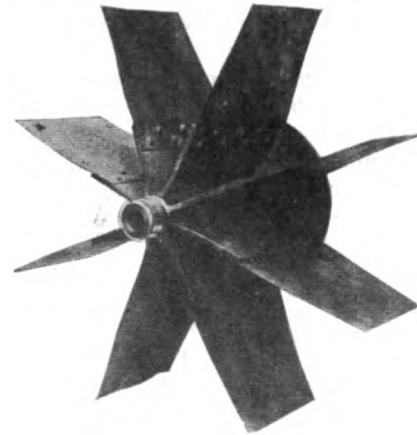

VENTILATOR TO BE CENTERED IN TUBES.

the rings of tubes. It is claimed that efficiency is so much greater by this system that instead of running the fan at two or three thousand revolutions a minute, as is often done, it can be run at 1,200 revolutions and supply all the draught required. By this system the radiator is completely independent of the hood of the motor and has the advantage of not drawing in dust on the engine, as is done when the fan is placed immediately behind the radiator. A claim of robustness is put forth on the grounds that the rings of tubes are merely clasped between the two steel plates, and that the group has a certain suppleness which prevents it suffering from road shocks. The radiator has been used on stationary engines, the fan being driven by belt off the engine flywheel.

The warm water arriving from the motor by the upper collector is distributed through the tubes to the lower collector, from which it passes, cooled, to the engine again. At the same time the centrifugal fan is drawing in cold air by the central opening and throwing it upon

"To instantly locate a knock beyond the shadow of a doubt, borrow a stethoscope and use it on the motor as a doctor would on a patient," says a young auto engineer who is also an M.D. Of course, every autoist cannot borrow such an instrument, and the majority would not know how to use it if they could, but the facility and certainty with which it distinguished a knock as being in the wrist pin of a certain cylinder, all other tests failing, was certainly amazing.

## LETTERS INTERESTING AND INSTRUCTIVE

### LAYING UP A CAR FOR THE WINTER.

Editor THE AUTOMOBILE:

[1,093.]—I would thank you very much for some information on the following. In laying up my two cars for the winter in my suburban home on Long Island, both of which are of the same make and both two opposed cylinder engines, I ask: If I open the pet cocks in the radiators, will it completely exhaust the water from the radiators and the cylinders, or whether enough might remain to cause freezing and damage. Again in jacking up the car, taking the weight from the tires, is it better to allow them to be fully inflated or to deflate the tires, or only partially so? Also, will gasoline left in the tank freeze in low temperature? Also, would you suggest in allowing the lubricating oil to be left in the oiler or withdraw same? Should the spark plugs be removed from the cylinders and a small quantity of kerosene put in to prevent rust? In short, any information that you can give me as to minor details of laying up a car for the winter will be fully appreciated, and I think beneficial to the owners who care for their own cars.

Trusting you to answer this in your most instructive column of "Letters Interesting," I remain,  
T. C. SNEDEKER.  
New York City.

Putting a car out of commission for the winter may consist of anything from running it into the barn and closing the door, to a most elaborate process, but it is not advisable to adopt the first extreme and not necessary to go to the latter. Whether the radiator petcock will drain the entire system of water or not, depends on its location. If it happens to be the lowest point in the circulating system it will, but it is advisable to open other connections, as at the pump, or other convenient point as low as possible in order to be certain of getting all the water out. We should think that it would be preferable to have the tires partially inflated, but tire experts may disagree on this point, however. Before leaving them this way, they should be removed from the rims, and if the latter show any signs of rust, this should be removed and the rims given one or two coats of shellac, the tires being replaced after this has dried. The gasoline is not at all apt to freeze at any temperature usual in this latitude, but as it constitutes an element of danger in that it is considered to greatly increase the fire hazard to any building in which it is present, it is preferable to empty the tank. This also applies to the lubricating oil, but for a different reason, namely, that the oil may thicken or gum in the tubes and be more difficult to remove in the spring. Empty the entire lubricating system and flush it out with gasoline. It is also advisable to inject a little kerosene in the cylinders, but the plugs should be replaced. Any bright steel parts that are apt to rust should be coated with grease or thick oil.

### DERANGING THE VALVE-TIMING OF THE MOTOR.

Editor THE AUTOMOBILE:

[1,094.]—In letter No. 1,062, published in the January 2 issue of "The Automobile," a subscriber asks you the following: "If, in timing an engine, the two to one gear is slipped one cog either forward or backward, can the correct timing be made again with the commutator, pushing it either forward or backward?" You answer that it can, saying that moving the commutator will naturally compensate for shifting the gears. That is true as far as the ignition is concerned, but it is not also true that any change in these gears changes the timing of the valves themselves, and this cannot be corrected by moving the commutator. Would not your answer to this question be liable to cause him some trouble?

Brattleboro, Vt.

CHARLES A. SMITH.

It would, unless, as we presumed, be the case at the time, it was only intended that the pinions should be revolved forward or backward, and not their camshafts, though as a matter of fact we must confess that this was something which was overlooked in answering the letter in question. If the timing gears were moved backward or forward, while attached to their respective camshafts, this would naturally move the inlet and exhaust cams one way or the other and a derangement of the valve-timing would necessarily follow.

### NOT THE BATTERIES THAT ARE FAULTY.

Editor THE AUTOMOBILE:

[1,095.]—Please answer the following in "Letters Interesting and Instructive." I use a Splittdorf coil, and for some reason the dry batteries do not seem to last but a short time. I have used "Ever Ready," Columbia, and two or three other good makes. By the time they have run 300 or 400 miles they will not register more than 1 or 2 amperes. I have a single-cylinder Oldsmobile runabout. Is it the coil? Is it because the batteries are grounded too long? I have followed the instructions of the manufacturer in the length of revolution of engine in grounding batteries, 1-3 of one revolution of engine, which is a four-cycle.

SCHUYLER G. FOSTER.

Allegan, Mich.

It is quite evident that the cells you have been using have not been at fault, but that the trouble is to be found either in the timer or coil, or possibly both. We presume you wish to be understood by "grounded for 1-3 of a revolution" that this is the duration of the contact employed to produce the spark, in which case it is nothing strange that you have had experience of this nature with dry cells. While makers differ on this point, 50 to 60 degrees on the crank circle is ample to allow for advancing and retarding the time of sparking, slightly more being allowed for advancing than retarding. This would be only 1-6 of a revolution, but as a matter of fact, we do not believe that as much as this is allowed on the majority of present-day cars, so that you are wasting a very large percentage of the current delivered by the batteries. The Oldsmobile runabout was not distinguished by a very advanced form of timer, and doubtless a new and up-to-date device, which could be fastened to the rear end of the camshaft most conveniently, together with the proper adjustment of the coil, would remedy the difficulty.

### WHAT PREVENTS A WORM GEAR STRIPPING?

Editor THE AUTOMOBILE:

[1,096.]—Could you answer a few questions through your valuable medium "Letters Interesting and Instructive?" Some cars, foreign, I believe, employ a worm drive. My question is: Why do not these gears strip when the driven member of the transmission becomes the driver, as is the case when the power is shut off? I have before me an "ad" cut from some journal, giving an illustration of a Christie touring car. Could you, or have you, described this car (either tourist or racer) in detail? Mr. Christie has made such a radical diversion from standard lines that, while we are all familiar with its appearance, I find few people who know much about its mechanical features. All they know is that it is front drive, but when they try to enumerate, I find they do not know much more than myself. Perhaps your answer will be long, but I know you will go a long distance out of your way to oblige a writer—much more than several editors which I have in mind.

Brooklyn, N. Y.

ROYAL H. WALTERS.

A number of heavy 'buses, which we believe are still in daily use in London and vicinity, are equipped with a worm drive. The same is true of the Mitchell commercial cars made in this country, and it has been reported from time to time that others were considering its adoption. The reason that these worms do not strip when driven by the car instead of driving it, is due to the fact that the pitch of the thread has been calculated to avoid this, in which respect they differ from the ordinary worm gear.

The Christie racing car which was run in the Grand Prix in France and in numerous races in this country since then, was described in detail in the issue of THE AUTOMOBILE of April 11, 1907. The transversely placed engine drives the front wheels directly through the medium of a conical friction clutch at each end of the crankshaft, so that when the car is running on the direct drive the wheels are practically on extensions of the crankshaft, universal joints being interposed to allow for relative movement, and they make one turn for every revolution of the motor. To provide a low speed forward, a small pinion attached to the center of the



crankshaft meshes with a large spur pinion on a countershaft running parallel with the former and inside the crankcase. At its ends this countershaft carries pinions which mesh with gears attached to the driving clutches of the front wheels. The cylinders of the motor carry copper water jackets, the exhaust valves being placed in the center of the head, while eight small automatic inlet valves are placed round it in a circle. Both the cylinders and the pistons are of steel. The maximum engine speed is 1,200 r. p. m., and as the direct drive gives one turn of the road wheels for every turn of the engine, the car is capable of a speed of two miles a minute. In the construction of the touring car since brought out, standard practice has been followed to a great extent; valves are mechanically operated, iron cylinders and the like. The change speed gear is mounted on the countershaft referred to and three speeds are provided by gears sliding on it, the drive being from the end of this shaft to the wheels, there being no direct connection between the latter and the crankshaft as in the racer.

### A PROBLEM IN VIBRATION.

Editor THE AUTOMOBILE:

[1,097].—Kindly tell me what it is that makes the vibration on the right side of the car so much greater than on the left. I have noticed with several different cars that the mud guards, lamps, etc., on the right side become loose much more frequently than those on the left side. I cannot myself arrive at any reason for this, but I am as sure that the fact exists as I am of my own inability to explain it.

HIRAM BAINBRIDGE.

Mattoon, Ill.

The only thing we can suggest is that the greater vibration on the right is caused by the torque reaction of the motor. Most automobile engines run to the left, counter clockwise, as viewed from the seats of the car, with the result that the frame and body tend to revolve in the opposite direction, compressing the springs on the right more than those on the left, and very possibly giving rise to the vibration you describe. This is simply our idea. If it is correct, things should loosen most frequently on the left side of the few shaft-driven cars in which the motors turn opposite to the usual direction, and should loosen no oftener on one side than on the other or any chain-driven car. Perhaps some of our friends driving cars with double-chain drives and with back-handed motors will be so good as to further enlighten us.

### PLACING A SMALL ENGINE IN A LARGE CAR.

Editor THE AUTOMOBILE:

[1,098].—At what horsepower would you rate a two-cylinder, two-cycle gas engine of 4 1-4-inch bore by 3 3-4 stroke, at 1,500 r.p.m.? What arrangement (size and kind of muffler and piping) would you advise to make this engine perfectly silent? At what speed (miles per hour) would you gear a 7-passenger machine weighing about 1,400 pounds with engine mentioned above, friction transmission, and double side chain drive to 28-inch wheels? Also what size of full elliptic springs (intend to use four) would you advise for above machine, with solid rubber tires?

SIMPLEX.

Seattle, Wash.

Granting that the efficiency of your motor is good, it should show 14 to 15 horsepower at this speed under favorable conditions, i.e., assuming that the motor draws in a fairly full charge and gets rid of the greater part of it when running at this rate. Use 1 or 1 1-4-inch wrought-iron pipe for the exhaust and lead it aft with as few turns as possible until the muffler is reached. State your requirements, giving motor dimensions, and the like, to a manufacturer of the latter and let him supply you with a muffler. This will be far easier and less expensive than attempting to make it yourself, although there is nothing complicated about a muffler.

It strikes us you are rather ambitious in making a seven-passenger car with such a small engine, although the car weight given is very low. We should not advise gearing the car to do more than 15 to 20 miles an hour on the high-

speed, if it is intended to transport such a load. For the suspension, a pair of 36-inch springs with six leaves 1 1-2 inches wide, on the rear, and 32-inch springs with six leaves one inch wide for the forward pair, should make the car ride comfortably when loaded. These figures are not based on any particularly accurate data, and it will be found that the action of the springs will depend to a very large extent on the nature of the material of which they are made. The figures given could be increased slightly if the maximum load were always to be carried, but it would make the car ride very stiffly when empty.

### WHAT IS THE CAUSE OF THIS LOSS OF POWER?

Editor THE AUTOMOBILE:

[1,099].—Will you please answer a few queries of mine in the next issue of "The Automobile?" I have an 8-horsepower, single-cylinder runabout, and having had trouble with the motor recently had the cylinder rebored and a new piston installed. Since doing this the car has neither the power nor the speed it had before the repair was made. In reboring 1-32 inch was taken off, and the man who did the work said the car would have more power and speed than ever. Should not the connecting rod have been lengthened in order to give the same compression as before, as I note that the motor no longer has a high degree of compression as before the work was done? The valves are tight, and I have installed a new coil, as well as a new Schebler carbureter. I have done everything possible to improve the running of the car, but cannot get the power or speed out of it that it had previously. Any information you can give me will be appreciated.

F. L. CLARK.

Chicago, Ill.

If the new piston were of the same length as the old one, there appears to be no reason why the connecting rod should have been lengthened in order to give the same degree of compression as formerly. But it may be that in fitting the new piston, a shorter one was procured, as this appears to be the most likely cause of the drop in compression, if it be true that the valves are perfectly tight and the piston rings make a good gas-tight fit with the cylinder walls. Assuming, however, that the piston is of the proper length and there is no leakage, it would seem very likely that the trouble is due to improper timing, either of the valves or of the ignition, in reassembling the motor. The intake valve should open just previously to, or exactly at the moment, the piston reaches the upper dead center, and should not close again until the piston has started upward on the compression stroke, 15 to 20 degrees on the crankcircle. The exhaust valve should open about an equal distance prior to the completion of the power stroke, and should close just before the inlet valve begins to open on the suction stroke. In both cases this is termed the *lead* given the valves and is essential to efficient running in any high-speed motor. Test the openings of the valves and see if they correspond to the above, or come close to it. The ignition should be set so that it can be advanced some 20 degrees or more, measuring on the crank circle—i. e., 20 degrees before the piston reaches upper dead center, and so that it can be retarded 10 or 15 degrees after passing that point. If you find that an examination of the motor verifies these details, there seems to be little doubt that the compression is at fault.

### BALL THRUST BEARINGS.

Editor THE AUTOMOBILE:

[1,100].—I am building a car of my own design in a small shop here, and I am planning to use annular bearings throughout the transmission, but I am somewhat at a loss as to what provision to make for the thrusts, since the makers advertise both thrust and radial bearings, and yet commend the use of the latter for taking thrusts—a practice that seems to be followed by many makers of high grade cars. If you can enlighten me as to the respective merits of these two types of bearings for thrust loads, and the determining factors, which call for the use of one kind or the other, I will be vastly obliged. There are not so many cars or authorities on them in this part of the world as there are in olden communities, and the consequence is that we have to secure our information at long range.

MELVILLE E. TELFORD.

Melbourne, Australia.

The special thrust ball bearings you mention are considerably smaller for given loads than are the radial ball bearings used for thrust. They are, however, less suitable for high speeds and for constructions in which there is any side play, though two types are made—one for very low speeds with both races grooved, and the other for higher speeds with one race flat—to allow for slight inaccuracy. One of the races of all these bearings has a spherical seat, that it may accommodate itself as exactly as possible to the direction of the load. Evidently with this construction the least misalignment of the seat of the other race on the shaft, or of the shaft itself, will produce a rapid rotation of the spherical member, certain to cause trouble at very high speeds. The radial bearings used for thrust permit very high speeds, but must not be used in this manner for much over one-third of their radial load capacity. And for all but very light loads they are not advised for carrying both the radial and the thrust loads in the same bearing, two adjacent bearings being used, one so mounted as to receive one load while the second receives the other.

#### WHERE CAN LICENSES BE PROCURED?

Editor THE AUTOMOBILE:

[1,101].—Where in New York City can application be made to obtain a chauffeur's license?  
R. H. W.  
Brooklyn, N. Y.

To our knowledge there is no place in New York City where applications for chauffeur's licenses may be filed. Apply to the Secretary of State, Albany, direct. Blank applications, however, are usually to be had at many of the garages.

#### TO MAKE CYLINDER CASTINGS LIGHTER.

Editor THE AUTOMOBILE:

[1,102].—Having built several motor trucks and wishing to construct a large truck without the usual weight and trouble of cracked, coarse-grained and pin-holed cylinders, I went to an iron expert of years standing and told him of my desire for better cylinder construction. After a year's experimental work in the melting of iron, he built me a four-cylinder engine with cylinders so light and of such apparent thinness that I at first refused to accept the engine. However, on his personal guarantee I placed it in a large truck, and after eight months of the hardest kind of usage, after being subjected to the severest kind of tests and engine overheated, I believe my friend has discovered a new process in the melting of iron that will be eagerly sought after by all manufacturers of automobile cylinders.

The following explanation will serve to show practical foundrymen that this new process will avoid the difficulties caused by the present method of melting iron for automobile cylinders.

Why is the first iron drawn from the cupola harder than the succeeding withdrawals, the iron mixture and other conditions being the same? The iron, on leaving the melting point in a cupola does so in dribs, globular in form, coming in contact with the coke on its way to the bottom. Each globule is deflecting when uniting with other dribs, at the same time absorbing sulphur and other foreign substances, which cause a great degree of hardness to the iron. This trouble is augmented by small particles of iron coming in contact with the cold blast, on its passing the tuyeres. The cold blast comes in contact with it in a comparatively finely divided state, the action of the cold blast having the effect to chill the iron, partially eliminating and combining its graphitic carbon in the iron before reaching the bottom. Owing to this defect and the sides of the cupola not having the heat equal to the melted iron, the iron is again chilled and more graphitic carbon is converted into combined carbon. By the time the first charge is down, small ducts or veins are formed, with the fuel below the melting point and by slag adhering to the fuel, the melted iron keeping the passage open in the ducts during the entire heat. As soon as formed, this passage protects the iron in its downward course from any action from the blast, hence no material change occurs in the iron on account of the cold blast. When the iron reaches the bottom, the latter being heated by the iron previously passing over it, it will not be subjected to the chill which the previous iron was accorded, and again we have less cause for variations in mixtures than we had with our first charge and melt. Considering the above explanation as facts, it seems no strange matter why affairs are thus.

For the manufacture of automobile cylinders by this process we find that the iron is very close in grain, and very soft and toolable. It is absolutely free from pin holes. The iron is sufficiently soft to caulk, and is very fluid in consistency, equal to semi-steel in tensile

strength. Under this process, automobile cylinders can be made much lighter than under the present method of melting iron.

The writer would be glad to give further information to any one interested.

Warsaw, Ind.

ALLEN S. WIDEMAN.

#### ANOTHER AUTOIST'S "IDEAL" AUTOMOBILE.

Editor THE AUTOMOBILE:

[1,103].—I have seen in the columns of "The Automobile" at various times sets of general specifications which their authors state as representing their respective ideal cars, but none of these seem to me to be all that they might be. I am not an active participant in the sport, but have studied automobiles from a mechanical standpoint for several years, and the following specifications represent what I consider to be as near the ideal car as can be had with the present knowledge of gas engines. This ideal car would be of medium power and weight and have a seating capacity of five adults. Specifically the weight would be about 2,000 pounds. The car would ride on 34 by 3 tires in front and 34 by 4 tires in the rear, where much more than half of the work is done. The wheelbase would be about 110 inches, and the track 56 inches.

For a motor, I would have a three-cylinder, two-cycle, air-cooled, vertical engine of 30-35 horsepower, supported from the main frame at three points in the usual forward position. The drive from the motor would be a multiple-disc clutch in the flywheel, and thence, by means of an inclosed propeller shaft with one universal joint at its forward ends, to a sliding gear set in an integral casting with the bevel gear housing on the rear axle. The tube which inclosed the propeller shaft would be arranged to take the thrust and torque set up by the transmission of the power. The gear set would have four speeds ahead and one reverse, direct drive being had on the third speed. The rear axle would be of the floating type.

The frame would be of pressed alloy steel, of channel section, with a drop in front of the rear axle. It would be supported on semi-elliptic springs in front and three-quarter platform springs in the rear.

The frame would be of pressed alloy steel, of channel section, with would be made up of the usual clutch, accelerator, and brake pedals, only the clutch and brake pedals would be reversed for convenience. The change gear and emergency brake levers would operate on concentric quadrants, the one the full gate type, and the other of the usual ratchet pull-up form. The throttle and spark levers would operate on a stationary sector on top of the steering wheel, with the throttle lever long enough to reach to the rim of the steering wheel. Steering would be wheel-actuated, with a fully adjustable worm and unit, all connecting links being joined by ball-and-socket joints, and the cross connection link lying in back of the front axle, where it is protected from harm.

I would use a dual system of ignition, one system being operated from storage batteries and the other operated from a low-tension magneto with coil, the whole so arranged that either or both systems may be used at the will of the operator.

While my motor and control location do not conform to common practice, they seem to me to be the simplest and most convenient, and in the case of the motor, as efficient as almost any of the modern cars.

Worcester, Mass.

FRED B. FAY.

#### FURTHER DATA ON IGNITION ECONOMY.

Editor THE AUTOMOBILE:

[1,104].—The case of the dry battery vs. the magneto is very well presented in the letters of E. Leeds Powell and Herbert L. Towle in your recent issues. As Mr. Towle says, if the dry battery were called upon to furnish only the current necessary for ignition, it would last long enough to answer every ordinary purpose, even without considering the possibility of making batteries that would outlast those now in use. We understand that the Semi-Dry Battery Co., of Newark, make a battery in which the chemicals are contained in a thin paste, instead of being absorbed in the blotting paper, as in the ordinary construction. Possibly this is the battery which Mr. Powell has in mind. Its makers claim that while its capacity is perhaps no greater, it does not dry out as soon as other kinds.

A consideration which is not alluded to by Mr. Powell or Mr. Towle is the fact that when contact is made and broken mechanically, the current required for this purpose must be stronger than that required to make a spark. The Atwater-Kent spark generator is the result of a great deal of research and experiment with the view of consuming the smallest possible current, and the results obtained with it are due, not simply to the fact that only one spark per ignition is made, but also to the fact that contact is made and broken mechanically by a shaft driven from the engine; so that it takes place with equal positiveness, whatever the strength of the battery may be. In addition, the duration of the contact is extremely brief, and is constant, regardless of the engine speed, though capable of being adjusted by the operator to suit the

strength of the battery. Users of this device report mileages all the way from 1,000 to 3,000 or more in service on six ordinary dry cells. In view of these facts, we believe we have come as near as possible to the ideal method of economizing battery current.

Philadelphia, Pa. A. ATWATER KENT.

### EFFICIENCY OF THE FOUR-WHEEL DRIVE.

Editor THE AUTOMOBILE:

[1,105.]—Will you kindly give me space in your next issue of "The Automobile" to answer the question, "What is the efficiency of the four-wheel drive," as asked in your communication No. 1046, published in the December issue? I have had practical experience with a four-wheel driven auto, and have come to the conclusion that the four-wheel drive is the only practical method of applying power to a vehicle.

In the first place from 25 to 40 per cent. of the power is saved; second, the vehicle will not slough or skid in mud, snow or sand. I consider this a very important item, as sloughing is the cause of numberless bad accidents; third, it does not wear out only about half as many tires, for the reason that when you apply the power on all four wheels they turn, and the machine moves, and the wheels do not skid, as they do very frequently on a rear-wheel drive, thereby grinding off the tires; fourth, the mechanism of a four-wheel drive will outwear that of any other machine, for the reason that all back chuck caused by striking obstruction in front is eliminated, as the driven wheels climb over the obstruction rather than bumping into it.

I am running a four-wheel drive under a twenty-horsepower, two-cylinder motor geared to run 1,200 revolutions a minute empty, the power is reduced to permit the vehicle to run thirty miles per hour. With this machine with 30-inch wheels, weighing 2,700 pounds loaded with nine people averaging 140 pounds each, I have climbed a 10 per cent. grade 600 feet long, on the direct speed.

Is there a rear-wheel driven machine on the market with the same rate per horsepower which will do the same work? The machine I am driving is manufactured by the Four Traction Auto Company, of this city.

ERNST ROSENBERGER.

Mankato, Minn.

### DISAGREES WITH MR. FAY ON CARBURETION.

Editor THE AUTOMOBILE:

[1,106.]—It is greatly to be regretted that anyone who knows so much about certain phases of automobile engineering as does Mr. Thos. J. Fay should jeopardize his reputation with those who are well informed and mislead those who are not by such erroneous statements and poor English as appeared in his article in the issue of January 2.

Mr. Fay ought to know by this time that the richness of the mixture increases with increasing speeds unless special provision, such as the modern auxiliary air valve, is made to prevent it; that the scavenging effect is better at high than at low speeds because of the greater momentum of the issuing gases during the expulsion stroke; that it is no more difficult to time the spark properly at high than at low speeds, but that for a given rate of flame propagation there is a certain piston speed, beyond which it is inexpedient to run because the ignition cannot be advanced sufficiently to give full combustion without causing too much back pressure toward the end of the compression stroke; and that it is the product, not the sum, of torque and speed that determine the horsepower.

An abridged dictionary will tell Mr. Fay that it is "constriction," not "depression," that is required in the intake pipe, where the nozzle is located, and that to "combust" is not by any means to "burn."

Time and space limitations preclude anything like an exhaustive enumeration of the lesser errors, but the foregoing are ample to indicate what might be considerably designated as the carelessness of utterance which mars what could have been made an excellent article.

CECIL P. POOLE,

Editor, "Power."

New York.

### AN AUTOIST TAKES MR. FAY TO TASK.

Editor THE AUTOMOBILE:

[1,107.]—As I am a constant reader of your paper, I respectfully ask your privilege to differ with Mr. Thos. J. Fay on one point, in his article, "The Fuel System of Automobiles." He claims that the needle valve for adjusting the flow of gasoline in a carbureter is of no use at all. He says, after two years' trial, he finds it serves no useful purpose at all; in fact, it does some harm, as it eliminates the true nozzle effect. I will agree that if a carbureter has been fitted to a particular engine by getting the opening in the nozzle just right, which can be accomplished only by many trials and with the use of a brake, satisfactory results may be obtained. But should such carbureters be furnished by the different makers for use with different engines, would not the repair men have a pleasant time getting them properly adjusted? I have also found the needle valve

a good friend when gasoline of different density is used and when the float has become a little "cloggy," for it is then but the work of a moment to slightly cut down the opening of the nozzle, when the same amount of fuel can be had without further trouble.

Now it is just as easy to locate the needle valve between the float chambers and the nozzle (as some makers do), in which position I am sure he will agree it does not interfere with the nozzle effect in the least. It makes possible the use of as clean a mixture as the engine will operate on successfully, which in turn means a cool engine and less gasoline bills.

The fact that such builders as Franklin, Duryea, Thomas, and many others of unquestioned reputation use this form of adjustment would seem to indicate that it must be of some use, at least.

Phoenixville, Pa.

LEWIS T. RHOADES.

### ANOTHER PHASE OF "POLISHED vs. UNPOLISHED."

Editor THE AUTOMOBILE:

[1,108.]—Brass, nickel, and painted lamps have had their innings in issues of "The Automobile," October 17 and December 19. Each have their respective merits. It must be acknowledged that there is no substitute for clean brass. Now, Mr. Manufacturer, you equip your cars with elegant bodies, especially the limousine, using many permanent brass fixtures and fittings fastened directly against elegant upholstery, trimmings, or painting. These fixtures are not exempt from tarnishing, and tarnished brass was well compared to a dirty linen collar.

Metal polish is most detrimental to fine paint or fabric. Lamps can be removed and satisfactorily polished, but what is to be done with these many permanent brass parts inside and outside of sensitive finished bodies? True, some can be partly polished by holding a clean cloth next to the part liable to permanent injury, but this is like the man who cleans his shoes and neglects the heels.

I believe that the experienced men in this special department ought to be able to overcome this evil, and if there is no fit substitute, they can at least avoid much unnecessary display of brass, as the finest carriages do not require a lot of brass to give them elegance.

M. G. AUGSPURGER.

Cincinnati.

### WILL J. G. C. EXPLAIN THOSE OIL FIGURES?

Editor THE AUTOMOBILE:

[1,109.]—In your issue of January 2, J. G. C., of East Orange, gives the cost of running his automobile 6,000 miles. It is very interesting, but presents nothing out of the ordinary except that part wherein it is stated that he averaged 387.09 miles to a gallon of cylinder oil. This is so obviously an error that I hope I may be permitted to ask him to throw a little light on the subject. I am running a car similar to his in all respects but one—a runabout instead of a touring car—and when I average 100 miles to a gallon I think I am doing well. And I know lots of others who think the same.

New York City.

MUNCH HAUSEN.

### "NATURE-FAKING" AND THE "FOUR vs. SIXES."

Editor THE AUTOMOBILE:

[1,110.]—Apropos of the six versus four-cylinder controversy, one correspondent says, "Let us look back to Nature," a horse has four legs and not six." Continuing the "nature faking," how about the alrships? They use motors having eight, twelve, and sixteen cylinders, while birds have only two! Is it because flying insects have six legs and four wings? Submarines should have no cylinders at all; only turbines being au fait; but they will get there just the same. Has Maxwell his eye on the centipede? Next!

Rochester, N. Y.

E. T. BIRDSALL.

### SOMETHING FOR MR. SHANKS TO ANSWER.

Editor THE AUTOMOBILE:

[1,111.]—I noticed in your issue of December 19, that C. B. Shanks takes exception to the comparison by a four-cylinder enthusiast of what a horse can do with four legs, and brings forth the ostrich as an exponent of the two-cylinder. Does he take into consideration the comparative wheelbases of the two "birds" when it comes to smooth running?

Los Angeles, Cal.

J. MURRAY PAGE.

### A HELPING HAND FOR FORD OWNERS.

Editor THE AUTOMOBILE:

[1,112.]—I have noticed on several occasions complaints from owners of the Ford runabouts about their engines using too much battery. I had this trouble for a time, but have overcome this. I will be glad to give any owner of the Fords my experience if they will write me.

Coleman, Texas.

W. A. GRAY.

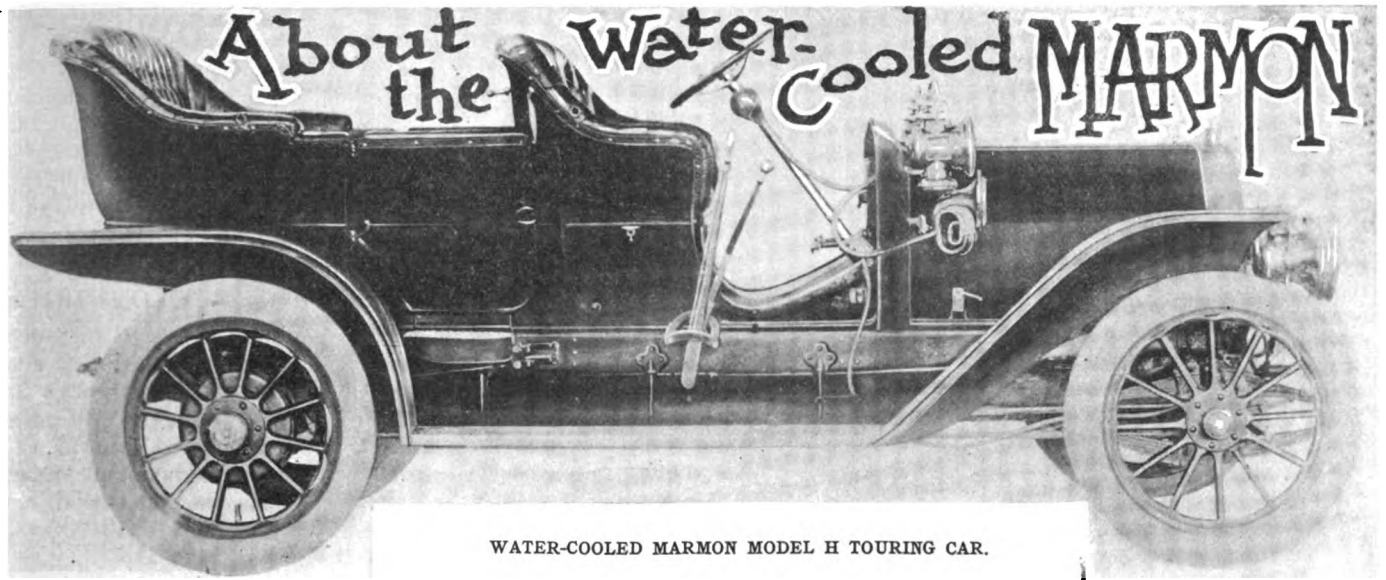

WATER-COOLED MARMON MODEL H TOURING CAR.

**I**N adding a water-cooled car to its line for the season of 1908, the Nordyke & Marmon Company, Indianapolis, Ind., is simply making a bid for the business of that large class that prefers a water-cooled type of motor. The success of the Marmon air-cooled car ever since it has been on the market speaks for itself, and the builders will devote more attention to this line than ever in future, as is evidenced by the improvement in motor design recently chronicled in these columns. This is the adoption of a new form of detachable cylinder head, which is a radical departure from the practice of casting the cylinders in one piece, that has numerous advantages. The numerous distinctive features that have characterized the Marmon air-cooled car have all been embodied in the chassis of the newcomer, so that there will be no difficulty of identifying either type as a Marmon product at first sight.

The new car is known as the Model H, and is equipped with a four-cylinder motor in which the cylinders measure 5 by 5 inches, and are cast in pairs. A special grade of iron is employed, and liberal water spaces have been provided, while the water piping is also of ample diameter, circulation being by means of a gear-driven centrifugal pump. The valves have a clear opening of 2 1-4 inches diameter and are made with taper seats, all being interchangeable. Particular attention is paid to the valve mechanism, a hinged lever with a

hardened steel roller in its outer end riding on each cam lifts the valve tappets, thus preventing

side thrust and consequent wear in the guides. These roller levers are hinged in bronze holders set in ports in the sides of the crankcase and held in place by yokes. The crankshaft is a single steel forging two inches in diameter with a flange made integral on one end to receive the flywheel. The shaft itself is hollow and is mounted on Parsons white brass bearings of liberal dimensions. The connecting rods are drop-forgings and the pistons are made very long in order to give a smooth-running motor at high speeds and prevent excessive side thrust against the cylinder walls due to the short connecting rods, the latter measuring 13 1-2 inches while the pistons are 7 1-2 inches long. The connecting rod big-end bearings are also made large and of the same material as the main bearings. A feature that adds greatly to the structural strength of the motor is the carrying of the cylinder fastening bolts through the crankcase so that they also form the crankshaft bearing cap bolts, thus tying the cylinders and the crankshaft together with steel. These bolts are, in reality, studs held permanently in place, so that the removal of the cylinders does not disturb the bearings, or vice versa. The nuts holding the bearing caps are set up against steel plates and not against the aluminum of the crankcase. Cooling is provided for by an improved type of cellular radiator with a large belt-driven fan directly behind it.

Two complete and entirely independent systems of ignition are provided, a high-tension magneto with the spark plugs set over the intake valves forming one, while a timer and four-unit coil supplied with current from a set of batteries and sparking through plugs set over the exhaust valves completes the other system. The exhaust gases are carried to the manifold through separate ports, while the intake manifold is cast integrally with the cylinders and is water-jacketed, thus permitting the use of a large diameter passage without the risk of the fuel condensing in the intake when the motor is running at a low speed. This manifold only requires a short piece of tube to connect it to the carbureter and insures an even distribution of the mixture. The motor's

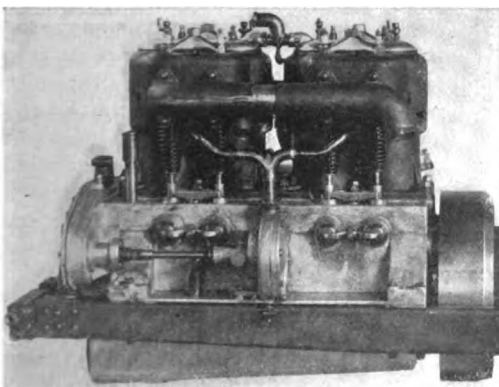

side thrust and consequent wear in the guides. These roller levers are hinged in bronze holders set in ports in the sides of the crankcase and held in place by yokes.

The crankshaft is a single steel forging two inches in diameter with a flange made integral on one end to receive the flywheel. The

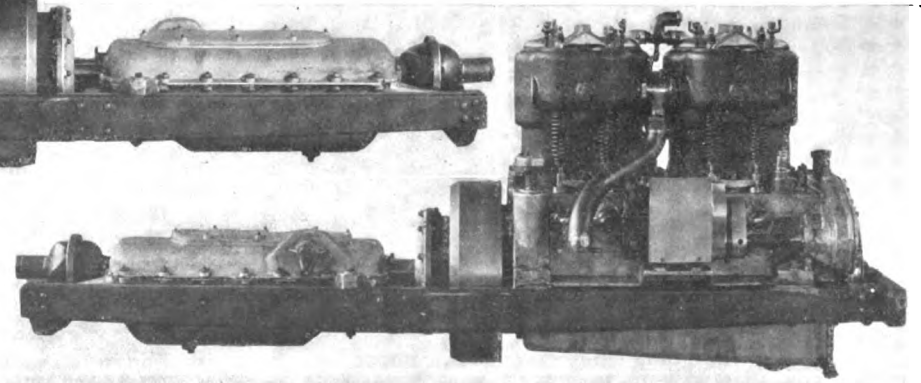

RIGHT AND LEFT HAND VIEWS OF THE MARMON UNIT POWER-PLANT.



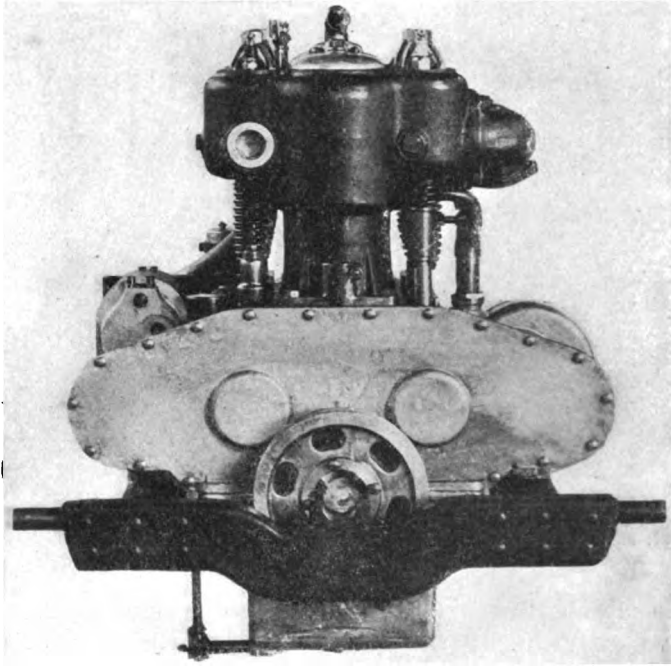

FORWARD VIEW OF THE NEW MARMON WATER-COOLED MOTOR.

rating is 40-45 horsepower, but as numerous brake tests have shown results considerably in excess of this, it does not represent its actual capacity by any means.

A multiple disk clutch of exclusive design is employed as an intermediary between the motor and the change-speed gear-set, all three of these essentials being combined in the form of a unit power plant, as shown by the accompanying photographs. The clutch consists of several bronze plates thickly studded with cork inserts faced on both sides, and alternate steel plates. The disks are inclosed in a case secured to the flywheel and run in oil. A series of coil springs engage the disks and small supplementary springs aid in disengaging the disks, when the pressure is released. It is designed to have considerable excess capacity over that of the motor and transmit the power in an extremely smooth manner. The gear-set is of the sliding type operating on the selective plan and providing three speeds forward and reverse. The pinions and their shafts are made of special steel subjected to heat treatment, and are mounted on larger annular ball bearings inclosed in an oil-tight and dust-proof aluminum case. A simple, automatic locking device placed on the outside of the housing makes it impossible to shift the gears without first disengaging the clutch, and it also insures the full meshing of the gear teeth before the clutch can be let in. A simple brake is also automatically applied whenever the clutch is released in order to slow it and the gear shaft so as to facilitate gear changing; this brake naturally does not affect the speed of the car.

Where the remainder of the car is concerned, it suffices to say that it is distinguished by the numerous features of design and construction that have become familiar through their long, successful use on the air-cooled Marmon. Some

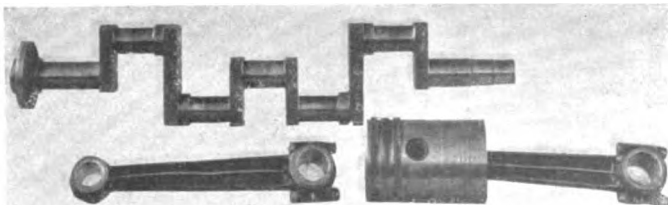

SOME OF THE CHIEF ESSENTIALS OF THE MOTOR.

of these are the double three-point suspension in which the motor is carried on one frame and the weight of the car on another, both being free to respond to every inequality of the road; the Marmon oiling system and roller-bearing steering column, cast aluminum body and the like. The Model H. is listed as a five or seven-passenger touring car, and also as a roadster carrying either two or four passengers. The chassis of the latter is built especially for it as a roadster type and embodies the latest ideas of design.

### CONTINENTAL PRODUCES IN THREE COUNTRIES.

PARIS, Jan. 7.—The latest important addition to the automobile city which has sprung up and is still growing fast on a bend of the Seine outside Paris is a model factory for the Continental Tire Company. Six large shops, constructed of reinforced concrete, will, when completed, employ two thousand workpeople in the production of automobile and bicycle tires, rims and tissue for balloons. M. Bader, the commercial manager, declares that the works will be fully completed and turning out tires by October next.

In addition to the home factory at Hanover, Germany, the Continental has now two foreign factories of consider-

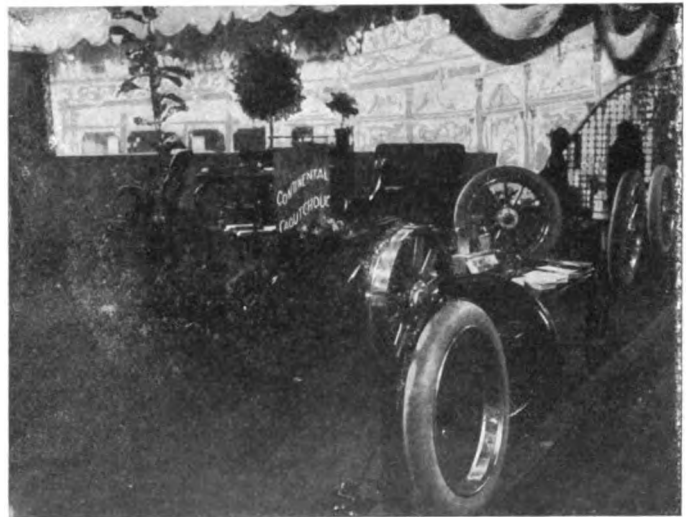

EXHIBIT OF CONTINENTAL TIRES AT RECENT IMPORTERS' SALON.

able importance, the one in the suburbs of Paris and another in Massachusetts, where a portion of the American demand is met. The Hanover factory, together with the subsidiary house at Seelze, employ 6,700 workpeople, said to be the largest number engaged by any single tire-making concern. The home factory was established in 1872, long before the automobile industry had been created, the American factory dates from 1907 and the French house will come into operation in 1908. The full line of goods handled by the company will be produced at both Paris and Hanover, the American works not yet being sufficiently extensive to meet all demands in the United States.

The making of demountable rims is now forming a very important feature of the Continental factories, this time-saving device, first tested in important racing events in 1905, being declared to be the pioneer of rims of this class. Another important branch in the Hanover factory is the fabrication of rubber tissue for balloons and airships. Important among the envelopes made by Continental was that of the ill-fated French military dirigible *Patrie*, the most successful airship ever built. It is expected that this branch of the firm's activity will be well developed at the new French factory, there being a greater demand for balloon tissue in France than anywhere else in the world.

## IN THE MAKING OF A ROLLER BEARING

Probably there is nothing quite so difficult for the lay mind to grasp as the number of processes and operations that are essential to the production of even the most simple mechanical devices. Take a roller-bearing, for instance—whether considered as a whole or separated into its components, there is nothing complicated or intricate about it, and, offhand, the average man would be of the opinion that it was a correspondingly simple and easy thing to manufacture, particularly in quantities. Nothing could more effectively dispel such a notion than a trip through the plant of the Timken Roller Bearing Axle Company, at Canton, O., but as such opportunities come to few autoists, a brief review of some of the more important steps in the evolutions of the well-known anti-friction bearings made by this company will be of considerable interest.

All manufacturing naturally begins with the selection of the material, and errors in this important preliminary are not only irremediable, but become magnified in the process of evolution, so that lack of due care at the outset would be apt to render the finished product worthless. After years of experience and experimenting, the Timken company settled upon an open-hearth nickel steel, low in sulphur and phosphorus, as the best material

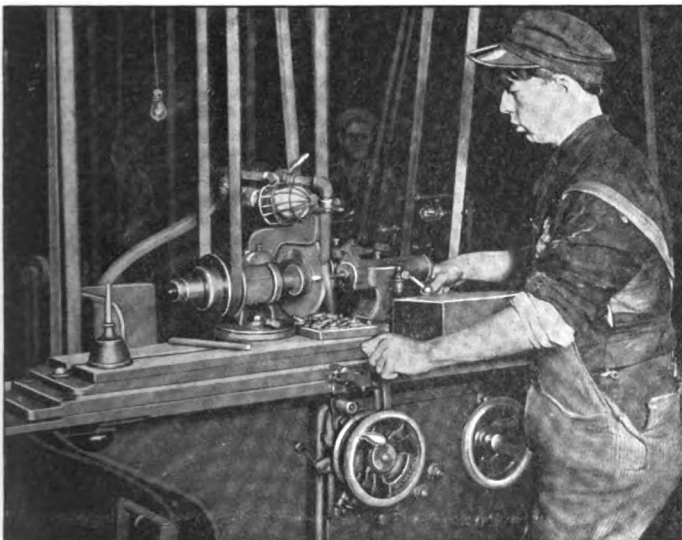

GRINDING TIMKEN TAPER ROLLERS ON AN AUTOMATIC MACHINE.

for the rollers of their bearings. This is made to the Timken analysis and 45 per cent. of each ingot is "cropped" or rejected, in order to insure metal of suitable density and soundness. As the roller-bearing carries its load equally distributed at all contact points, all the rollers in the same bearing are subjected to an equal amount of wear, so that it is of the greatest importance that all should wear alike, uniformity of material being essential.

Though these preliminary steps are of vital importance and comprise not a little of the cost of the finished article, they are of secondary interest to the average layman, who is chiefly concerned in the machine work involved—the actual production of the bearings themselves. As is naturally to be expected in a plant of such size, every operation is carried out on a scale designed to lower the cost of production to a minimum. Compared with the price at which these bearings are sold in the market, the expense of duplicating one of them in an ordinary shop by the usual methods would cost an utterly prohibitive sum. Consequently, automatic machinery and the latest modern methods are to be found as the basis of every one of the operations through which the different parts pass. For instance, the first step after the material emerges from its various tests, is the making of the rollers, cups and cones, which are all turned out on automatic screw machines, designed to work the special Timken steel in the forms of rods and bars up to six inches.

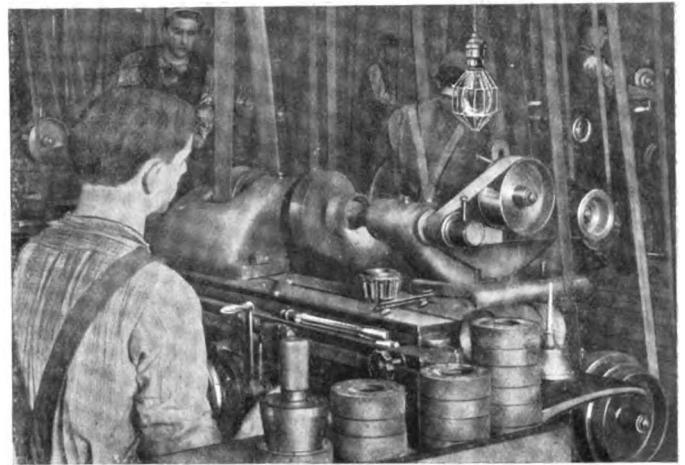

SPECIAL MACHINE FOR GRINDING ROLLER-BEARING CUPS.

At first glance, it might seem that examination, testing and assembling would mark the end of the process and that the bearings would then be ready for service, but this is far from being the case. After being finished to shape and size, these parts are first carbonized by packing in a special carbonizing compound, consisting of animal charcoal, in iron boxes, which are heated in special furnaces and subsequently allowed to cool slowly. The parts are next heated in automatic revolving gas furnaces so that each piece of metal passing through them is subjected to the same degree of heat. From this second furnace they are suddenly quenched in oil in order to give the outside surfaces the requisite combination of hardness and toughness—in other words, qualities which fit them to withstand crushing loads as well as wear. The first process is generally known as case-hardening, for which a battery of special furnaces has been installed at the Timken plant, and the second as oil-tempering.

Here again, it might be thought that the process had now come to an end, and that only the final operations of assembling and testing remained, but it is only after the operations already described have been gone through that the most delicate part of the work of producing such bearings comes in. The hardening process referred to always causes more or less distortion of the parts, which have previously been machined closely to dimensions, but as yet have not been brought to that degree of absolute accuracy that is essential to the successful production of such a device as a properly designed anti-friction bearing. To attain this by counteracting the slight warping effect of the hardening furnaces and to get the parts down to micrometer gauge, they are placed in special grinding machines. Owing to the extreme accuracy required, as well as the fact that as little as possible

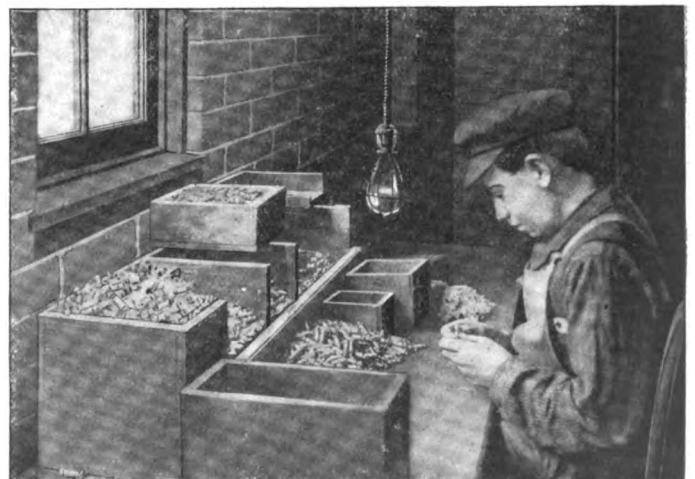

SORTING TIMKEN ROLLERS AFTER THE FIRST GRINDING.



ASSEMBLING THE FINISHED AND TESTED PARTS.

of the specially hardened surface should be ground away, this is an operation requiring special machinery and more than the usual skill on the part of the machinist. The taper rollers are finished on automatic grinding machines.

Throughout every detail of all these various processes, however, nothing is left to chance or rule-of-thumb work. Each succeeding lot of materials, and the parts into which it is transformed, is closely watched as it progresses through the different stages. In the converting boxes, 12 rollers are wired together

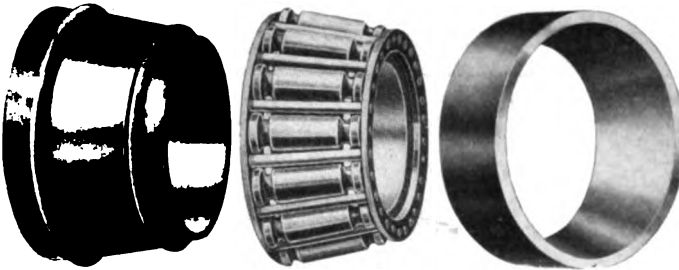

ESSENTIALS OF THE COMPLETED TIMKEN ROLLER-BEARING.

and packed in the center of each box that goes into the case-hardening furnace. These 12 rollers are test specimens, and on the completion of the heat are taken to the laboratory, where they are broken and the fractures etched with acid to determine the depth of the case-hardening—or in other words, the conversion of the surface of the parts into high-carbon steel. In this manner uniformity is insured to the greatest degree possible. After the grinding process has been completed, the finished rollers go to a tester where they are gauged for uniformity of diameter in order that only rollers very closely approximating

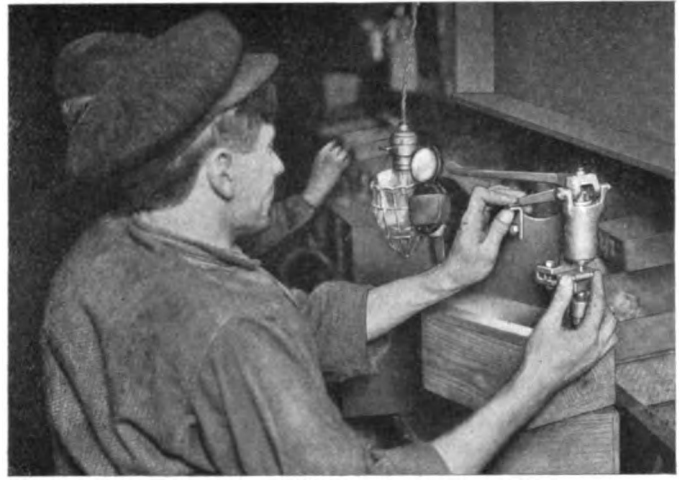

MICROMETER GAUGING THE ROLLERS FOR .002-INCH VARIATIONS.

one another in diameter at the center of the load-carrying surface, should be assembled in the same complete bearings. A difference of .002 inch causes the rollers to go into different boxes.

While these operations are being carried on in different departments of the large plant, the other essentials of the bearing are being turned out simultaneously. The cages and cage-rings are turned out in special machines, the latter being stamped and pierced in power presses. These cages carry no part of the working load, but are designed to give the individual rollers absolute freedom of travel between the cone and the cup. The rollers and cage-rings are next brought together at an ingenious riveting machine which combines the two into a circle of conical rollers loosely retained laterally by the cage-rings and studs, but accurately positioned endwise in the complete bearing assembly by the cone ribs, coacting with the roller grooves, so that each roller has the same load carrying apportionment when working. This is the next to the last step in the actual manufacturing, which consists of the assembling. After having gone through all these lengthy and intricate processes, of none of which the appearance of the simple device gives the slightest hint to the uninitiated, the original material has been converted into the finished roller-bearing. It is a product as perfect as the skill of the metallurgist, the chemist and the expert machinist, aided by modern machinery and methods, can make it, but all of this would constitute a recommendation of doubtful value to the user, if he found that the bearings gave out in actual service. Accordingly, science, skill and care are supplemented by actual trials of bearings from successive lots. These are placed in a special testing machine and subjected to stresses far beyond what they will ever be called upon to bear in actual service, so that their capacity for work is well established.

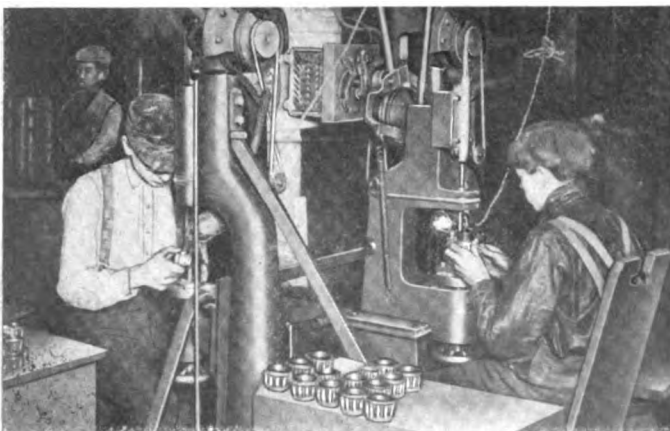

RIVETING THE CAGE RING STUDS HOLDING THE ROLLERS.

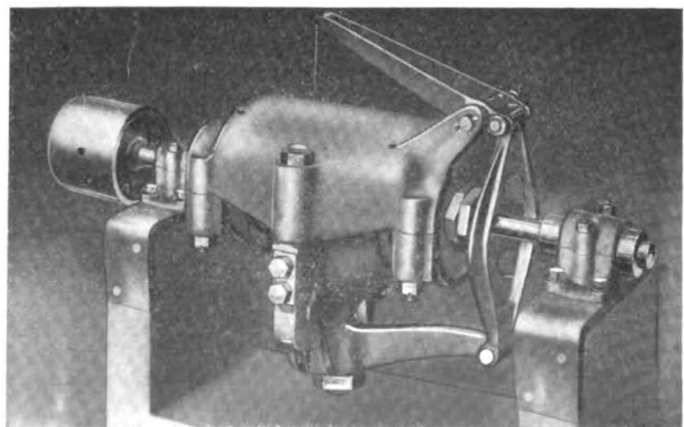

SPECIAL MACHINE FOR TESTING BEARINGS, TIMKEN LABORATORY.

## THE AUTOMOBILE CALENDAR.

### AMERICAN.

#### Shows and Meetings.

- Feb. 1-8.....—Providence, State Armory, Automobile Show. Frank M. Prescott, manager.
- Feb. 3-8.....—Kansas City, Mo., Convention Hall, Automobile Dealers' Association of Kansas City. W. L. Walls, secretary.
- Feb. 10-15.....—Detroit, Light Guard Armory, Tri-State Automobile and Sporting Goods Association, Seventh Annual Show.
- Feb. 17-22.....—Cleveland, Central Armory, Annual Show, Cleveland Automobile Dealers' Association. George Collister, manager.
- Feb. 21-29.....—Newark, N. J., Orange A. C. Building, New Jersey Automobile Trade Association and New Jersey Automobile and Motor Club.
- Mar. 7-14.....—Boston, Mechanics' Building and Horticultural Hall, Boston Automobile Dealers' Association. Chester I. Campbell, manager, 5 Park Square.
- Mar. 9-14.....—Buffalo, Convention Hall, Sixth Annual Automobile Show, Automobile Club of Buffalo. Dai H. Lewis, manager.
- Mar. 21-28.....—Toronto Canada, St. Lawrence Arena, Automobile Show. R. M. Jaffray, manager.
- Apr. 5-12.....—Montreal, Canada, Arena, Third Annual Automobile and Sportsman's Show. R. M. Jaffray, Mgr.

#### Motor Boat Shows.

- Jan. 25-Feb. 1.—Boston, Mechanics' Building, National Association of Engine and Boat Manufacturers. Chester I. Campbell, manager, 5 Park Square, Boston.
- Feb. 3-8.....—Buffalo, Convention Hall, First Annual Power Boat and Sportsman's Show, auspices of Buffalo Launch Club. Dai H. Lewis, manager.
- Feb. 20-Mar. 7.—New York City, Madison Square Garden, Fourteenth Annual Motor Boat and Sportsman's Show. J. H. Dressel, manager.

#### Race Meets, Hill Climbs, Etc.

- Mar. 2-7.....—Ormond-Daytona, Fla., Automobile Club of America.
- Mar. 16-21.....—Savannah, Ga., Savannah Automobile Club.
- Apr. 24.....—Briarcliff Trophy Race, Westchester County, N. Y. Robert L. Morrell, Chairman.
- May 4-5.....—Harrisburg-Philadelphia and Return, 150-mile Endurance Run, Motor Club of Harrisburg.
- May 30.....—Bridgeport, Conn., Sport Hill Climb, Bridgeport Automobile Club.

### FOREIGN.

#### Shows.

- Jan. 18-Feb. 2, '08—Turin, Italy, Fifth International Automobile Exhibition, Palace of Fine Arts, Valentino Park, Automobile Club of Turin.
- Mar. 21-28.....—London, Agricultural Hall, Cordingley's Show.
- May 6-20.....—Moscow, Russia, International Automobile Exposition, Automobile Club of Moscow.

#### Races, Hill-Climbs, Etc.

- April 1-13.....—Monaco Motor Boat Races and Motor Boat Exhibition, International Sporting Club of Monaco.
- April 25-May 25—Industrial Vehicle Competition, Automobile Club of France.
- May.....—Paris, Competition for Agricultural Automobiles, auspices of "L'Auto." (Exact date to be announced.)
- May 10.....—Sicily, Targa Florio, Automobile Club of Italy.
- June 1-18.....—Reliability Trials for Pleasure Cars, Automobile Club of Great Britain.
- June 9-17.....—Touring Competition for the Prince Henry of Prussia Prize, Germany, Imperial Automobile Club of Germany.
- June 20-July 5.—Grand Prix, Dieppe Circuit, Automobile Club of France. (Exact date to be announced.)
- July 13-17.....—Ostend, Belgium, International Race Week, Automobile Club of Ostend.
- July 20-30.....—Ardennes Circuit Races and Coupe de Liedederke, Automobile Club of Belgium.
- Aug. 1908.....—France, Coupe de la Presse, Automobile Club of France. (Exact date to be announced.)
- Aug. 29-30.....—France, Mont Ventoux Hill Climb, Vaclousien Automobile Club.
- Sept. 1-8.....—French Voiturette Contest, auspices of "L'Auto."
- Sept. 27.....—France, Chateau-Thierry Hill Climb, "L'Auto."



Photo by C. G. Smith, Daytona, Fla.

AN EARLY "OLD" ARRIVAL AT ORMOND-DAYTONA, FLA.

### A FINE POINT IN CUSTOMS COLLECTION.

WASHINGTON, D. C., Jan. 13.—The United States Supreme Court has been asked by the Attorney General to decide whether the owner of an automobile of foreign manufacture can be required to pay duty on the machine a second time when it has been kept abroad for a year and extensively repaired. The United States Circuit Court of Appeals for the Second Circuit held that duty could be collected only on the new part of the machine, but the government contends that it should be paid on the entire article.

### MR. MILTOUN RECEIVES TUNISIAN DECORATION.

Francis Miltoun, a frequent contributor to THE AUTOMOBILE, during his last journey in the Regency of Tunis was decorated and made an "Officier du Nichan Iftikhar" by the Bey of Tunis, for exceptional services, as the "brevet" reads.

Mr. Miltoun has voyaged much *en automobile* through Europe, and has exploited many hitherto unheard-of or neglected beauty spots among all classes of travelers. His last book, "In the Land of Mosques and Minarets," is now in the hands of his publishers (Messrs. L. C. Page & Company, of Boston).

Mr. Miltoun promises THE AUTOMOBILE an article in the near future on "Roads and Roadmaking Abroad," which, with the latest information concerning the art of modern road building as pursued in the French colonies and protectorates of old Africa, should make interesting reading.

The hotel accommodations in Tunisia are by no means backward, as the photograph sent by Mr. Miltoun plainly shows.



MR. MILTOUN AND HIS CAR IN FRONT OF TUNISIAN HOTEL.





Vol. XVIII Thursday, January 16, 1908 No. 3

THE CLASS JOURNAL COMPANY

Flatiron Building, Madison Square New York City

H. M. SWETLAND, President

EDITORIAL DEPARTMENT

A. G. BATCHELDER, Managing Editor R. F. KELSEY, Associate Editor C. B. HAYWARD, Engineering Editor W. F. BRADLEY

BUSINESS DEPARTMENT:

A. B. SWETLAND, Business Manager LOUIS R. SMITH FRANK B. BARNETT W. I. RALPH, 1035 Old South Building, Boston, Mass. C. H. GURNETT, H. E. WESTERDALE, 836 Monadnock Block, Chicago, Ill.

Cable Address - - - - - Autoland, New York Long Distance Telephone - - - - - 300 Gramercy, New York

SUBSCRIPTION RATES:

United States and Mexico - - - - - One Year, \$3.00 Other Countries in Postal Union, including Canada - - - - - One Year, 5.00 To Subscribers—Do not send money by ordinary mail. Remit by Draft, Post-Office or Express Money Order, or Register your letter.

FOREIGN SUBSCRIPTION AGENTS:

ENGLAND:—Hilffe & Sons, Limited, 20 Tudor Street, London, E. C. FRANCE:—Boyveau & Chevillet, 22 P. de la Banque, Paris. GERMANY:—A. Seydel Mohrenstrasse 9, Berlin.

Copyright, 1907, by The Class Journal Company. Entered at New York, N. Y., as second-class matter. The Automobile is a consolidation of The Automobile (monthly) and the Motor Review (weekly), May, 1902, Dealer and Repairman (monthly), October, 1903, and the Automobile Magazine (monthly), July, 1907.

Table with 2 columns: Year and Copies printed. 1905: 730,000; 1906: 791,000; 1907: 888,000

Knowledge the Chief Requirement of the Legislator. "One man can lead an ass to knowledge, but ten men cannot make him think," is an apt way of paraphrasing the familiar saying that is very appropriate at the moment. Leaving out of the question the strength of such ulterior influences as "constituents" and "perquisites" in deciding the passage of legislation adverse to the automobilist and the industry, it stands to reason that if the average rural "Solon" could be reasoned with and made to think a bit he would not declaim quite so loudly about downing the automobile and taxing the "rich owners" to the limit. Eighteen months' enforcement of the obnoxious Frelinghuysen law shows that by its non-reciprocal provision it has done more harm to the State of New Jersey as a whole than the money received from the extra licenses taken out can possibly compensate for. The matter of amending it in this and other particulars is now being broached, and, if the Jersey legislators can be made to think a bit, there should be no difficulty in bringing about this result.

It would be hard, indeed, to cite a better example of the beneficent effect of having some knowledge of a matter which has to be regulated by law than Mayor McClellan's recommendations to the metropolitan aldermanic body regarding the control of automobiles in New York City. With the constantly increasing number of cars in the streets of the metropolis, small things that were scarcely noticeable a few years ago have assumed the proportions of decided nuisances. Chief among these are the production of clouds

of lubricating oil smoke, the constant use of sirens, and the blinding glare of large acetylene headlights at night, and in his message the Mayor laid particular stress on each one of them as something which should be forthwith abolished. If the average legislator would gain a little knowledge of the automobile and be guided by it, there would be a noticeable absence of abortive attempts at legislation.



Commercial Drivers Need Not Be Skilled Mechanics. Because a French newspaper was offered the use of a taxicab company's vehicles to hold a breakdown competition open to all, but attracting no drivers of public cabs, an effort has been made in certain quarters to prove the usefulness of more skilled training for the men who are fast superseding the public hackman. A man who can adjust the platinum points on a magneto and time the ignition of a strange car in 11:18; discover and remedy a short circuit in the magneto in 1:28; discover that the carbureter nozzle had been stuffed with paper, remove it, and have his car going in five minutes—a man who can show such a record should be ashamed to be driving a taxicab. Cab companies, indeed, cannot afford to keep such men at the comparatively unskilled task of steering a small automobile rendered as automatic as it is possible for human ingenuity to make it.

Just as in modern factory practice, where a four-loom weaver knows little and cares less of the structural features of her machine, or the linotype operator confines his attention to the keyboard and the output of slugs, so the taxicab has created a demand for a class of men who may be thoroughly capable of running a car without knowing much about the operations under the bonnet. Every operating company, without exception, insists that its men shall not tinker. Their duty is to run the vehicle according to instructions, and if it fails to perform in a normal manner, to call for expert aid. Commercially it is quite impossible to operate any large number of automobiles except by employing unskilled or semi-skilled labor. No company can afford to employ an expert for each machine, and still less to keep tinkers in its service. As the horse is gradually ousted from the commercial world, there will be an increasing demand for men who are nothing more than drivers.



An Achievement the A. C. A. May Well Be Proud of. If, in its long career, the Automobile Club of America had not succeeded in accomplishing anything more than the successful installation of the Wheeler dynamometer, the completion of which was made the subject of a public demonstration at the large clubhouse in Fifty-fourth street last week, it would still deserve to have its name go down in history as having been the most progressive organization of its kind in this respect. There have been dynamometers of one kind or another ever since there has been anything which developed enough power to make its measurement a matter of sufficient curiosity to its builder or owner, and as was naturally to be expected, many of them have been utilized in connection with the automobile, but neither here nor abroad has there ever been such an elaborate and costly installation made for the purpose.

Large manufacturing interests occasionally go to great expense in fitting up laboratories and testing rooms to further the improvement of their own products, but even in such cases the outlay seldom exceeds that necessary to devise such an elaborate and costly assemblage of apparatus as that now permanently installed on the top floor of the Automobile Club of America's house, and which may be taken to have been designed, not merely for the benefit of the club members alone, but for that of the entire industry.

## WHAT THE LEGISLATIVE BOARD OF THE A. A. A. IS DOING

**C**HAIRMAN CHARLES THADDEUS TERRY, of the Legislative Board of the American Automobile Association, at the recent meeting of the executive committee of the national organization, presented a report which contained much material of great moment to automobilists generally. In the course of his report Chairman Terry commented as follows:

**First.—The Federal Automobile Law.**—Arrangements were completed by your Board with Honorable William W. Cocks, congressman from the State of New York, for the reintroduction of the bill prepared by your committee in its effort to secure a system of Federal registration and identification of automobiles, to the end that the annoyance of the varying State requirements in these regards might be eliminated. This was so thoroughly and so promptly accomplished that this Federal bill was introduced on the very opening day of the present session of Congress, to wit, the Sixtieth Congress. The bill is known as House Bill Number 428, and was referred to the Judiciary Committee of the House. The list of the members of that committee has only recently been completed by the Speaker of the House, and forthwith upon their appointment the chairman of your committee procured from Washington the names and States respectively of the members of the committee, and here sets them forth, so that they may be on record for future reference, because your committee, and, we hope, every member of this association, will make occasion to have much to do with the said committee, both collectively and individually, before the close of the present session:

### COMMITTEE ON THE JUDICIARY OF THE HOUSE OF REPRESENTATIVES.

John J. Jenkins, Chairman,	Chippewa Falls,	Wisconsin.
Richard Wayne Parker,	Newark,	New Jersey.
DeAlva S. Alexander,	Buffalo,	New York.
Charles E. Littlefield,	Rockland,	Maine.
Charles Q. Tirrell,	Natick,	Massachusetts.
John A. Sterling,	Bloomington,	Illinois.
John H. Foster,	Evansville,	Indiana.
Henry T. Bannon,	Portsmouth,	Ohio.
Reuben O. Moon,	Philadelphia,	Pennsylvania.
Gerritt J. Diekema,	Holland,	Michigan.
George R. Maiby,	Ogdensburg,	New York.
Henry S. Caulfield,	St. Louis,	Missouri.
David A. DeArmond,	Butler,	Missouri.
Henry D. Clayton,	Eufaula,	Alabama.
Robert L. Henry,	Waco,	Texas.
William G. Brantley,	Brunswick,	Georgia.
Charles C. Reid,	Morrilton,	Arkansas.
Edwin Y. Webb,	Shelby,	North Carolina.

Your Board is now engaged in the preparation of letters to be sent out from the office of the association to all the clubs enrolled in the association and to each individual member of the association, as well as to any and all friends of automobilists whom we can reach. We feel that no one who will give sufficient time and thought to acquaint himself with this bill can refrain from lending his support to the measure.

The chairman and secretary of your Board expect to meet Congressman Cocks and some others whose assistance is of importance in this regard in Washington within the next ten days to further the interests of the bill.

**Second.—State Motor Vehicle Laws.**—The outlook for sane and reasonable State laws concerning automobiles is exceedingly good,

with the prospect of the ultimate enactment by most of the States of our proposed uniform State Motor Vehicle Law very bright indeed. The one disappointing and disagreeable feature in the State law situation is presented by the incomprehensible attitude of the authorities of the State of New Jersey. There are no arguments to sustain their position in support of the obnoxious law on their statute books governing automobiles, except the frankly-confessed one that it provides revenues, and the remarkable part of the situation is that they consider that argument all sufficient. There are two provisions in the New Jersey statute, either one of which is sufficient to demonstrate the unfairness and the unreasonableness of those who advocated the passage of the measure, and both of which should elicit the hearty condemnation of every lover of fair play, whether he is an automobilist or not. Those provisions are, in a word:

(a) That a non-resident automobilist engaged in interstate travel shall not be allowed to cross a border of the State of New Jersey until he has made a trip to Trenton, paid his tribute to the State, with the emphasis on the tribute, and procured his license to exercise his natural common-law right to use the highways; and

(b) That no automobilist may traverse the streets or roads of this sovereign State of New Jersey until he has subjected himself to the humiliation of appointing as his attorney in fact a man whom he does not want to represent him, and whom he perhaps never heard of.

The law is an outrageous one, and unworthy of any self-respecting commonwealth. Every effort of the American Automobile Association and its friends should be bent to wipe from the statute books of that State this monstrous curtailment of the rights of users of the highways. So long as those provisions remain in force, every automobilist should be warned against entering the State of New Jersey and deterred from submitting himself to the indignities perpetrated by the statute of that State, and should be advised to take his tours in other sections of the country, where he can get just treatment. If the only argument for the State statute is that it produces revenue, let that argument be demolished by a demonstration that, deterring automobilists from entering the State of New Jersey, will result in a loss of a thousand dollars of money spent and left within that State for every dollar that would be paid by non-residents for license fees. This is one of the effective ways, and perhaps the most effective way, of dealing with that situation at present.

**Third.—Local Ordinances.**—The danger to be incurred by automobilists in deprivation of their rights, from any recurrence to the anciently asserted privilege of municipalities and other local bodies to pass ordinances of regulation to suit themselves, is obvious, and clearly a great menace. Every such attempt at the promulgation of such ordinances should be struck at by this association wherever it appears. It was supposed, and justifiably so, that when that question was once threshed out in connection with the passage of the New York State Motor Vehicle Act, it had been settled for all time; but it remained for the Park Board of the City of New York to revive it in spite of the clear prohibition of the New York State statute, and in spite of all considerations of reasonableness and equality. Common-sense, the safety to the traveling public, others as well as automobilists themselves, justice and the laws upon our statute books require that the New York City Park Board should frankly and speedily recognize its error and repeal its misconceived ordinance.

## NEW JERSEY'S AUTO CLUBS TO WORK FOR A SANE LAW

**N**EWARK, N. J., Jan. 13.—The chief result of the meeting of the Associated Automobile Clubs of New Jersey at Trenton, N. J., last week was the passing of a resolution that W. F. Sadler, Jr., president of the associated clubs, appoint a committee to confer with Senator Frelinghuysen and others interested in the automobile law, with a view to arriving at an agreement concerning the amendments which are to be supported at the next session of the legislature. This conference will probably take place some time this month, and to it will doubtless be invited, in addition to the bill's original sponsor, Commissioner of Motor Vehicles J. B. Smith, and representatives of the grangers' and farmers' organizations, so that a complete understanding may be reached.

According to some of the press reports of the proceedings, it was stated that the delegates "voiced certain demands" to be presented to the legislature, but W. Clive Crosby, chairman of the legislative committee of the New Jersey Automobile and Motor Club, who, with J. H. Wood, represented the Newark organization at the conference, denied this emphatically.

"The intention of the meeting was not to make any demands, but to formulate the ideas which automobilists all over the State agree upon as being fair and recognized as such by all those who have carefully studied the subject," said Mr. Crosby to a representative of the *Sunday Call*.

"There was no mention made of saving the State \$30,000

by the abolishment of the personal license fee, as was reported in the daily papers. We did talk over plans for saving in the administration of the automobile law, but when we discussed the subject of personal license, it was simply from the standpoint that the personal examination, so-called, as now conducted, is a farce, as every motorist who has applied for a license knows. What we desired was that a man in New York State, for example, should be able to apply by mail direct to Trenton and obtain a license without going through the formality of applying in person at one of the offices of the deputy commissioners throughout the State.

"The spirit of the meeting was entirely harmonious and the

opinions expressed similar to those voiced at the meeting in Newark in December."

Those who attended as delegates the conference in Trenton last week were: New Jersey Automobile and Motor Club, W. C. Crosby and Joseph H. Wood; Northern New Jersey Automobile Club, Paterson, George A. Post; Automobile Club of Hudson County, Jersey City, J. H. Edwards and J. V. Z. Anthony; Union County Automobile Club, Plainfield, Dr. F. C. Ard; Mercer County Automobile Club, Trenton, W. F. Sadler, Jr., and James E. Gill; Atlantic City Automobile Club, Walter Edge; Camden Automobile Club, Mr. Sparks; Wildwood Automobile Club, Mr. Hammersley.

## NEW YORK STATE MAY HAVE NEW LAW AND ANNUAL FEE

ALBANY, N. Y., Jan. 13.—The special legislative committee of the New York State Automobile Association, appointed by President Oliver A. Quayle, held a session in Albany on Wednesday last. Present at the session, besides the State president, were William H. Hotchkiss, of the Automobile Club of Buffalo; S. M. Butler and W. W. Niles, of the Automobile Club of America; Russell A. Field, of the Long Island Automobile Club; H. S. Stilwell, of the Syracuse Automobile Club; Charles T. Terry, chairman of the A. A. A. Legislative Board; Frederick H. Elliott, secretary of the A. A. A.; A. G. Batchelder, New York City; Chauncey D. Hakes, secretary of the State Association, and Howard Martin, of the Albany Automobile Club.

The legislative situation was gone over thoroughly, and the final results will be made public in due course of time. Messrs. Terry, Quayle and Niles were designated as a sub-committee to complete the work outlined by the special committee.

### Chairman Terry Discusses an Annual Registration Fee.

Interviewed by a New York *Times* reporter, Chairman Charles Thaddeus Terry, of the A. A. A. Legislative Board, commented as follows upon the proposed new New York State law, which will contain provision for an annual registration fee:

"The prime reason for enacting an annual registration fee based upon the weight or horsepower of the cars is due to a general dis-

position on the part of motorists to do their share for the maintenance of good roads. The fee will not be recognized as a tax upon motor vehicles, for motorists are not disposed to acknowledge that they should be taxed exclusively for the use of the public highways, but they are willing to contribute their share of funds toward the good roads movement. Another important change will be in regard to speed regulations. In this respect we hope to embody the simple regulations of the uniform State act, which have been adopted in the Connecticut Automobile act, the most reasonable State motor law in the country.

"This states briefly that no person shall operate a motor vehicle at a rate of speed greater than is reasonable and proper, having regard to the width, traffic, and the use of the highway, and the general rules of the road, or so as to endanger property or the life and limb of any person. If it is necessary to state any specific speed rate beyond which the safety of other users of the road is likely to be endangered, a maximum of over twenty-five miles an hour in municipalities or built-up sections, when continued for half a mile, will be considered proof of negligence, and in the country a speed of over thirty miles an hour. The present New York law limits the speed rate to ten miles in thickly populated portions, fifteen miles in other localities, and twenty miles in the country. Under certain conditions these limitations are much too low, while in other cases they are too high, for an autoist in many parts of New York City would clearly be driving recklessly at six miles an hour, while in the open country he might readily travel forty miles an hour with perfect safety."

The uniform motor vehicle law, the basis of the proposed new New York statute, was prepared by the A. A. A. Legislative Board and imposes a different system of penalties than is now in vogue in the New York law.

## BUFFALO CANNOT IMPOSE ANNUAL TAX.

BUFFALO, N. Y., January 13.—Members of the Automobile Club of Buffalo are particularly pleased at a decision handed down by the Appellate Division of Rochester declaring unconstitutional and invalid the ordinance adopted by the Common Council of Buffalo imposing an annual tax of \$5 on all automobiles using the thoroughfares of Buffalo. This ordinance was enacted early last year, and all members of the Automobile Club were immediately advised by Secretary D. H. Lewis not to pay the tax, as the club had engaged former Supreme Court Justice Daniel J. Kenefick to attack its validity. Some, however, did pay the tax. The Municipal Court in this city decided against the municipal authorities, but an appeal was taken to the Appellate Division. The courts hold that the local measure conflicts with the State motor vehicle law.

## CHAINS QUESTION SPREADS TO QUAKERVILLE.

PHILADELPHIA, Jan. 13.—At last Thursday afternoon's session of the Fairmount Park Commission, a movement was started to exclude from the park any automobile having tires fitted with chains. Final action was not taken in the matter, which was referred to the Committee on Superintendence and Police.

## NEW YORK'S AUTO LEGISLATORS AT WORK.

ALBANY, N. Y., Jan. 13.—In the Assembly to-night two old anti-motor vehicle bills in a little different dress appeared. One was by Assemblyman Frederick Northrup, a Democratic printer of Poughkeepsie, who declares the big touring cars "cut the improved highways all to pieces." It is the old tax bill and amends the present motor vehicle law by calling for \$5 annually from each owner.

Another Democrat, a very new Assemblyman, a law student and clerk, representing the Twentieth District of Manhattan, Patrick J. McGrath, calls for an amendment to the penal code, which provides that "any person or persons, while conducting, managing, operating, or riding in an automobile, carriage, vehicle, or any other conveyance, who shall come into contact with, or in any way injure any person or the property of another, shall immediately stop, and, upon demand, give his true name and address, and the names and addresses of the person or persons to whom such automobile or conveyance belongs, and by whom such person is employed, to the person injured, or to the first policeman on the scene, or to any citizen present; and in default of same shall be guilty of a misdemeanor and upon conviction shall be punished accordingly."

This seems to apply to street cars as well as to automobiles, and its phraseology indicates the amateur draftsman.

## A.A.A. CLUBS ACCOMPLISHING MUCH THESE DAYS

### RESTFUL POLICY OF A. C. OF PHILADELPHIA

PHILADELPHIA, Jan. 13.—The policy of the Automobile Club of Philadelphia is to assist the authorities wherever possible in the suppression of the unlawful use of the automobile. In this connection the club's action in relation to an accident which recently occurred in Lower Merion township, Montgomery county, makes interesting reading. Its example could be taken with profit by other clubs. Following is a copy of a letter which was sent to the authorities of Lower Merion township on the occasion mentioned:

Philadelphia, January 7, 1908.

Honorable Algernon B. Roberts, State Senator,  
Philadelphia, Pa.

My Dear Senator Roberts:—

The Automobile Club of Philadelphia has instructed me to write and express to you, as representing Lower Merion Township, its approval of your course and its desire to co-operate with the authorities in every possible way in your efforts to discover the identity of the automobile driver who ran down a boy on Montgomery avenue, in Lower Merion Township, a few days since, and after injuring him severely drove off so rapidly as to prevent discovery. This organization is strongly opposed to the driving of machines at dangerously high speeds and to all forms of recklessness. The automobile club does not wish to prejudge a man or condemn him unheard, and does not therefore desire to be understood as expressing any opinion as to the guilt or responsibility for the accident in this case; but it does feel that the manly and wisest thing for a driver to do, under such circumstances, is to stop, give his name and render what assistance is possible.

We are, therefore, desirous to advise you that if the commissioners of Lower Merion Township deem it advisable, the Automobile Club of Philadelphia will be glad to add the sum of fifty dollars to the reward already offered by the commissioners for evidence leading to the discovery of the driver, whose automobile was concerned in the accident above referred to. It is our wish that you use your discretion in advertising this offer of reward, and we hold ourselves in readiness to pay it over to whomever you may designate upon advice from you.

Respectfully yours,

A. N. CHANDLER, President.

S. BOYER DAVIS, Secretary and Counsel.

A check for \$100 sent to the Automobile Club of Delaware County to assist that organization in its efforts to secure the co-operation of the farmers in bringing about the improvement of the main country roads, is another indication of A. C. of Philadelphia methods. That they are on the right track, is the opinion of all right-minded automobilists. At the same time they are prepared to fight extortion and injustice from the drop of the hat, as not a few of the borough and township officials of the country roundabout can bear witness, after legal encounters in which they were worsted.

### BUFFALO CLUB 1,127 AND STILL GROWING.

BUFFALO, N. Y., Jan. 13.—The membership of the Automobile Club of Buffalo is now 1,127, and in an appeal to members the newly elected president, Frank B. Hower, makes the following statement: "When the members of this club come to realize that our strength in controlling automobile legislation, both in the city and at Albany, depends upon the size of our membership, they will make it their business to influence every friend owning an automobile in becoming a member of the club. Remember when working for members you are working for yourself, for your influence is more powerful because your club is larger. We have now 1,127 members—let us make it 3,000. If each one will appoint himself a committee of one on membership and work, as you do in your business, the result will be astonishing. I assure you that the officers of this club are watching your interests."

The executive committee of the club consists of President Hower, E. R. Thomas and Charles Clifton.

### MARYLANDERS WILL CONTEND FOR SANE SPEED

BALTIMORE, Jan. 13.—At the second annual banquet of the Maryland Automobile Club, which was held at the Hotel Belvedere last Thursday night, plans were launched for the erection of a new clubhouse. As proposed, the plan includes the erection of a building with the first floor to be rented as offices and stores. One of the sites under consideration is that occupied by the old Baltimore & Ohio Railroad building at the corner of Baltimore and Calvert streets. One of the features of the new building would be a general dining room for members.

Osborne I. Yellott presided over the banquet and acted as toastmaster. The banquet hall was as though seen through green colored goggles. The tables, in the form of a gridiron, were splashed here and there with the color of blood red tulips and Jacqueminot roses, showing bright against the snow white linen, like rear lamps of a huge touring car. The menu card was calculated to maintain the reputation of the members of the club for originality. The souvenirs were badges of black and yellow ribbons (the Maryland colors) falling from a gold model of a touring car, and from the colors dangled an auto wheel, the hub of which was a brilliant red. The wheel was of gold and made an excellent watch charm.

Among those who responded to toasts were Mayor J. Barry Mahool, who talked of "Greater Baltimore and the Automobile," saying that the automobile was a great factor in the upbuilding of the suburbs. Other speakers and their toasts were: Water Engineer Alfred M. Quick, "The Water Wagon and the Automobile;" State's Attorney Eugene O'Dunne, "Crime and the Automobile;" Chief Engineer of the State Highway Commission W. S. Crosby, "Good Roads and the Automobile;" Milton D. Greenbaum, "The Ladies and the Automobile;" William D. Gill, "Alcohol as a Fuel and Otherwise." Covers were laid for 150.

In the course of his remarks, Mr. Yellott said that the legislative committee of the club would propose an amendment to the speed laws at this session of the legislature abolishing the present limit and substituting a discretionary limit to be determined by the condition of the roadway. He urged the abolishment of toll roads and the construction of State highways, and placed the club on record as favoring a Federal license for automobiles. The use of cars by drunken chauffeurs or owners was soundly scored, and promise was made to secure legislation on this point. Lastly, he declared that the club would endeavor to secure a State commission for the government of automobiles and the issuing of licenses.

### A. C. A. BANQUET WILL BE NOTABLE EVENT.

NEW YORK, Jan. 13.—The annual banquet of the Automobile Club of America, to be held in the Fifty-fourth street clubhouse on Saturday evening, January 25, will undoubtedly be the most important social event of the season in automobile circles. Instead of holding the banquet at the Waldorf or Sherry's as has been usual, the club is now in a position to entertain its guests in its own headquarters, its banquet hall, finished in the renaissance style of François I, being one of the largest and most beautiful in the country. The gathering will, in a certain sense, be a formal celebration of the completion of the finest and most up-to-date automobile club premises in the world.

As a tribute to the fact that France is the birthplace of the modern automobile, M. Jules Jusserand, Ambassador of the French Republic, will be the guest of honor, while the other



speakers include the Hon. Chauncey M. Depew, Augustus Thomas, Hon. Job N. Hedges, and Patrick Francis Murphy.

As Delmonico has charge of the catering, this year's feast will undoubtedly prove worthy of its superb setting. The seating capacity of the hall being limited to 361 persons, and 300 reservations having already been made, the committee in charge is confident that every seat will be taken before January 16, when the lists close. The committee in charge of the banquet is composed of A. R. Shattuck, chairman; Dave H. Morris, and Orrel A. Parker.

#### ANNUAL BANQUET OF NEW JERSEY'S BIG CLUB.

NEWARK, N. J., Jan. 13.—Among the guests of honor at the annual banquet of the New Jersey Automobile and Motor Club, to be held February 6, probably at Achtel Stetter's, will be William H. Hotchkiss, president of the American Automobile Association, and Commissioner J. B. Smith, head of the department of motor vehicles. During this week invitations will be sent out to other prominent men who have informally expressed their willingness to be present.

Arrangements for the Newark automobile show in February, to be held under the auspices of the New Jersey Automobile and Motor Club and the New Jersey Automobile Trade Association, are now well advanced. Application blanks for space were issued last week, and returns are expected within the next few days.

#### ANNUAL BANQUET OF THE BINGHAMTONIANS.

BINGHAMTON, N. Y., Jan. 13.—The second annual dinner of the Binghamton Automobile Club, which was held last week at the Armory Hotel, proved by far the most enjoyable of the social functions so far attempted by that live and hustling organization. Chairman F. P. Barnes and his fellow workers on the entertainment committee laid their plans so carefully that the affair moved without a hitch and gave enjoyment in profusion to the assembled members and their guests. President Benj. F. Weldon spoke in favor of a clubhouse for the organization, and urged renewed efforts to increase the membership, and Secretary S. M. Frechie spoke of the work done in the past and the possibilities of the club's future. Mayor C. M. Slauson spoke for the city of Binghamton, and numerous civic officials were in attendance at the banquet as guests of the club.

#### CHICAGO M. C.'S ENDURANCE RUN, JUNE 24-27.

CHICAGO, Jan. 13.—Quick action appears to be the watchword of the newly appointed contest committee of the Chicago Motor Club. Although but three days old, it got busy and announces that the feature of the 1908 season will be a 1,200-mile reliability run continuing four days. The dates selected are June 24-27, inclusive, and the rules will require each car to do 300 miles a day, instead of 200 miles, as was required in the 600-mile reliability which was won by the Haynes in 1907. The old "hub and spoke" plan will be adopted, the contestants returning to Chicago each night. The run will come in a few weeks ahead of the Glidden and it is expected will attract many makers who also contemplate taking part in the national tour.

In addition to laying out the "long-distance reliability," the contest committee decided that the campaign of 1908 would be opened in May instead of two months later, as in previous years. The hill climb is the first thing scheduled, for May 15, which has been advanced from second place on the annual card. The economy run is also pushed forward, being booked for August 14 instead of September.

A novelty discussed by the committee was a reliability test for motor buggies. It is proposed to put on a three or four day reliability run for which cars with wheels 38 inches in

diameter and over will be eligible. This will be a continuous test, starting from Chicago and running through the surrounding country for several days.

#### THE 1908 TOUR OF THE ALBANY A. C.

ALBANY, N. Y., Jan. 13.—The 1908 tour of the Albany Automobile Club will be held, beginning June 20, over the following route: Saturday (the 20th), Albany to Greenfield, Mass., 87 miles; Sunday, to Providence, R. I., 109 miles; Monday, to New Haven, Conn., 126 miles; Tuesday, to New York City, 80 miles; Wednesday, spent in New York; Thursday, to Waterbury, Conn., 92 miles; Friday, to Albany, 103 miles; total mileage, 597.

A committee was appointed to take direct charge of the McClure cup contest, which it was decided at a previous meeting should be over the same route and on the same dates as the club run, though under the supervision of this special committee: John Randerson, chairman; L. Melius, A. J. McClure, Walter Beattie, Dr. F. J. Cox, C. D. Hakes and C. S. Kelly. The club urges all interested persons or owners of machines to affiliate at once with it in order to secure most advantageous legislation on automobile matters.

#### LEE PRESIDENT OF BOSTON'S ENERGETIC CLUB.

BOSTON, Jan. 13.—Elliot C. Lee, formerly president of the American Automobile Association, and also for many years at the head of the Massachusetts Automobile Club, the pioneer organization of its kind in New England, has been elected president of the Bay State Automobile Association. Mr. Lee succeeds Lewis R. Speare, who has been president since the formation of the association three years ago, and who declined to be a candidate for reelection on account of the pressure of business duties, and because of the time required of him as vice-president of the A. A. A. and chairman of the legislative committee of the Massachusetts State Association. Harlan W. Whipple, of Andover, another ex-president of the A. A. A., was reelected vice-president, and Harry W. Knights and James Fortescue were reelected treasurer and secretary, respectively. The new board of directors consists of George W. McNear, an automobile and carriage body builder; Dr. Julian Hovestadt; Arthur P. Underhill, of the Reed-Underhill company, local agent for the Knox; J. W. Maguire, of the J. W. Maguire company, agent for the Pierce; and J. C. Kerrison. Dr. Hovestadt and Mr. Maguire are the new members. The Bay State Association is making plans for a busy season, and its officers will pay particular attention to legislative matters. The association begins the new year with a large and enthusiastic membership, and seems likely to maintain its leading position among the automobile organizations of New England.

#### WASHINGTON CLUB RE-ELECTS PRES. CAVERLY.

WASHINGTON, D. C., Jan. 13.—That the Automobile Club of Washington is in a flourishing condition and that it has accomplished a number of things beneficial to the automobilists of this city, was indicated by the annual reports of the officers submitted at a meeting of the club last Saturday evening. In recognition of the splendid services rendered by Robert B. Caverly, the members unanimously re-elected him president for the ensuing year. Secretary Leroy Mark was also honored with an unanimous re-election. Other officers elected were as follows: Vice-president, Harrington Mills; treasurer, Horace Chandlee; captain, F. B. Pyle; lieutenant, John Thomas. H. Chadwick Hunter, Col. C. E. Wood, W. D. West, and Arthur Newmeyer were placed on the board of governors. Steps were taken to increase the membership, and plans were made to carry on the good work of the club.

## HARTFORD'S AUTO SHOW MAKES A PROMISING START

**H**ARTFORD, CONN., Jan. 14.—It was a promising opening the show of the Hartford Dealers' Automobile Association had to-night at Foot Guard Hall. The building was artistically decorated, the crowd came in generous numbers, and sales were in progress before the exhibition was an hour old. Each exhibitor had the privilege of decorating his own space as he saw fit, and the result has been some very notable creations. There is not the uniformity seen at most of the shows, and the variety in decorating, as well as in life, seems to lend spice to the show.

Hartford being one of the pioneer automobile manufacturing cities in the country, its advantages are plainly apparent in the holding of a show. Many of the leading makes are on view, local agencies being possessed by many of the prominent concerns. The list includes these well-known names: Packard, Stevens-Duryea, Pierce-Arrow, Thomas, Corbin, Elmore, Atlas, Columbia, Ford, Pope-Hartford, Franklin, Knox, Cadillac, Oldsmobile,

Autocar, Mitchell, Maxwell, Waverley, Reo, Buick, Simplex, and Isotta Fraschini.

Of course the accessory folks are on view, the names including Post & Lester, Jones Speedometer Co., Stewart & Clark Mfg. Co., Lombard Speedometer Company, G. W. Fuller, Vacuum Oil Company, Visor Knitting Company, W. H. Wiley & Sons Company, A. L. Foster & Company, Aetna Life Insurance Company, Hartford Rubber Works Company, Veeder Mfg. Co., and the Bridgeport Vehicle Company.

The men behind the show are R. D. Britton, as president of the Dealers' Association; S. A. Miner, secretary; F. W. Dart, treasurer; and E. G. Biddle as the fourth committeeman.

The banquet of the Automobile Club of Hartford is scheduled for Thursday night, at the Hotel Garde, and is in charge of a committee consisting of C. H. Gillette, H. P. Maxim, F. W. Dart, G. E. Risley, and Walter Wakefield.

## GREATER PITTSBURG PREPARING FOR A GREATER SHOW

**P**ITTSBURG, Jan. 13.—Greater Pittsburg—achieved but a few weeks ago—is to have an automobile show worthy of it. Preparations are now going forward rapidly to make the show at the Duquesne Garden, April 4-11, one of the best that has ever been held in this country. The Automobile Dealers' Association of Pittsburg, under whose auspices it will be held, had a meeting last Thursday night and completed all preliminary arrangements for the show. So far they have decided to use more space, spend more money, have more exhibitors, and call in more skilled help in making ready the big exhibition hall than they did at the first Pittsburg show.



PRES. W. N. MURRAY.

Scenic mural decorations of a high order, uniformity in inscriptions and signs, artistic and effective draping of fine material and unsurpassed arrangements in electric displays have already been determined upon. Red and

white will be the prevailing colors. A touch of gold will relieve this combination. The accessory spaces will be more desirably situated than last year, for they will be against the wall and across the aisle from the automobile spaces. The main body of the hall is 340x135 feet, making a larger floor space than in Madison Square Garden, New York.

A handsome directory is now being prepared at the headquarters of the association. Prominent among the facts which it presents are these: There are 43 automobile dealers in Pittsburg; there are 82 automobile manufacturers represented in Pittsburg; there are over 3,000,000 people in the Pittsburg district; Pittsburg has more people within a radius of 75 miles than any other city in the United States, except New York and Chicago; Pittsburg has 1,000 millionaires; there are more high power automobiles used in Greater Pittsburg than in any other section of this country.

The show committee is composed of W. H. LaFountaine, Earl Kiser, Thomas I. Cochran and W. N. Murray. The Pittsburg Automobile Dealers' Association officers for this year are: President, W. N. Murray; secretary, A. L. Banker; treasurer, G. P. Moore; vice-president, W. H. LaFountaine; assistant secretary, A. E. Doherty.

## CHICAGO'S NEXT SHOW WILL BE HELD IN FEBRUARY, 1909

**I**T was confidently expected that last year represented the first and last trials of early show dates, and that in future a return would be made to former practice, action of this nature now having been taken by both the Licensed Association and the National Association of Automobile Manufacturers, the latter at its New York meeting, January 8. Show matters came up for discussion and were referred to the show committee, which decided to recommend at the next meeting of the executive committee that the next show be held two weeks after that at Madison Square Garden, which will bring it during the first week of February, 1909. The report of General Manager S. A. Miles, on the last Chicago show, revealed the fact that, despite the unfavorable conditions, the attendance was greater than ever before.

At the request of the American Automobile Association, S. D. Waldon and W. T. White were appointed to represent the association in an advisory capacity, and Messrs. Waldon, White and H. O. Smith were appointed a committee to attend the meeting of the touring board of the A. A. A.

One of the results of the meeting of the executive com-

mittee was the election of H. E. Coffin, representing the E. R. Thomas Detroit Company, to membership, Mr. Coffin being the first man to have this honor since the initiation fee has been raised to \$500. The association contemplates the establishment of a comprehensive traffic department, the subject being referred to the transportation committee of which Benjamin Briscoe is chairman.

The executive committee voted unanimously in favor of the adoption of the following resolution:

"WHEREAS, This association has been appraised of the sad death of M. L. Goss, a member of its executive committee, and one of the veteran members of the automobile industry; be it

"RESOLVED, That the Executive Committee, on behalf of the members and itself, deeply deploras the loss of an efficient associate, a man of valued counsels, a gentleman of endearing personal qualities and a friend, and that the sincere sympathy of this association, as a body, be extended to his bereaved widow and family.

Those present at the meeting were: Thomas Henderson, L. H. Kittridge, William R. Innis, R. D. Chapin, W. T. White, C. C. Hildebrand, S. T. Davis, Jr., A. L. Pope, William E. Metzger, and Charles Clifton.

### SCHEDULE OF ASSETS OF THE E. V. CO.

HARTFORD, CONN., Jan. 13.—John R. Hills and F. C. Billings, of Hartford, appraisers, and Halsey M. Barrett, of Bloomfield, N. J., and Henry W. Nuckols, of Hartford, receivers of the Electric Vehicle Company, have just filed in the Superior Court, through their attorneys, Bennett & Goodwin, an inventory of the real estate, plant, merchandise, patents and book accounts of the Electric Vehicle Company in the State of Connecticut, showing a total of \$1,709,603.08.

Under the head of "merchandise account," which includes finished parts, general stores, work in progress, finished vehicles, consigned cars, second-hand cars, stationery and the like, the company's inventory showed a total of \$1,093,565.70, which the appraisers have reduced to \$756,836. In the case of the book accounts the shrinkage has been greater proportionately, the total inventory value being \$143,939.57, and the corrected value being \$86,617.08.

"Schedule K" consists of the entire capital stock of the New Haven Carriage Company, of New Haven. This was acquired in 1899 for \$194,000, and in the interim it has paid more than \$200,000 in dividends, so that it is considered as one of the most valuable assets of the company, being listed as worth \$212,500. The final schedule of the inventory refers to the company's patent holdings and is as follows:

"Selden, Patent, U. S. Patent No. 549,160.

"This patent on a road engine is considered very valuable by the officers of this company, which holds the exclusive license with the right to grant sub-licenses for the use of this patent. We are informed by the receivers that the rights of the Electric Vehicle Company in this patent have been productive of a large net income during the past five years, which income has been in excess of \$500,000. This patent has still five years to run, and if the income from this source during the next five years shall equal or approximate that of the last five years, it is apparent that this patent is a valuable asset of the company." \* \* \*

### RUSHMORE DESIGN PATENTS UPHELD.

According to information supplied by the Rushmore Dynamo Works, Plainfield, N. J., their action for unfair competition which has been pending against the Manhattan Lamp Works for more than a year past, has been decided by Judge Ray in the United States Circuit Court, granting a permanent injunction against further manufacture or sale of imitations of the Rushmore lamps or parts, such as shells, rear covers, front doors, ventilators, etc., as well as enjoining the use of the name "flare front" in connection with searchlights by any other concern. The decision refers to a number of others of like nature as precedents, and in view of its sweeping effect, similar actions will be brought against other infringers who have pirated Rushmore designs.

In part, Judge Ray says in his decision:

\* \* \* "It seems to me that when defendant copied 'Rushmore' in every detail except functions and quality of material and weight of material, etc., in short, as to appearance, he had a purpose. This purpose is made evident when we look at what he did in putting the imitation on the market. That he did defraud and injure the complainant, and to some extent the public, cannot be questioned. That his acts led to confusion in the trade and among purchasers and users is self-evident. The result could not be otherwise. A person must be held to intend the known and reasonably to be apprehended consequences or results of his own acts, when such acts are knowingly and intentionally done." \* \* \*

### E. V. STRATTON BECOMES A STUDEBAKERIST.

In line with their policy of expansion, the Studebaker Automobile Company's New York branch at Broadway and Forty-eighth street has secured the services of E. V. Stratton, who for the past year has served so well as manager of the New York Automobile Trade Association. Mr. Stratton will be associated with C. F. Redden in the marketing, both wholesale and retail, of Studebaker cars. Mr. Stratton is peculiarly well fitted for his new position owing to his experience in the Trade Association during the past year.

### HOW THE TIRESMAKER VIEWS SITUATION.

A busy year for accessory branches of the automobile industry is predicted by W. B. Miller, sales manager and secretary of the Diamond Rubber Company. The basis of this statement is a careful analysis of reports from all sections. These reports indicate that the amount of renewal business to be done will be larger than ever before. The number of automobiles in use the past year will not be reduced. If some owners do not see fit to use their machines, the cars will pass to those who will. The number of new cars to be provided for, while not equal to that of 1907, will still reach, in the aggregate, a very large figure, making in the grand total a great extent of equipment necessary.

It is to be expected that business will be done along more conservative lines in all branches of the trade. The accepted forms of regular merchandising will prevail to a greater extent than formerly, and high quality, particularly in tires, will be demanded because of the true economy of using such products. The far-seeing dealer and consumer are both on the quality platform, and both alike working for the greatest economy in up-keep cost. That they should do so is highly desirable. The 1908 season will undoubtedly see greater discrimination in buying exercised by all automobile owners, and the general effect cannot but be healthful and beneficial to the industry as a whole.

### TAXICABS FOR CHICAGO WELL UNDER WAY.

To the Elmore Mfg. Company, of Clyde, O., goes the prestige of having placed in Chicago the first taxicab service installed in the "Windy City." Owen H. Fay, the Chicago agent for the Elmore car, is the man who will introduce and operate the taxicab service. It is expected that the Elmore taxicabs will be in operation sometime within the month. The chassis are practically completed at the Elmore factory, and as soon as the bodies and tops are received, the completed cabs will be rushed on to Chicago, where stands will be established at the Auditorium Annex, the Palmer House, and the Great Northern Hotel.

The Elmore taxicab engine will measure 24-horsepower, and the running speed of the cab, fully equipped, will be 35 miles an hour, carrying five passengers.

### POPE-HARTFORD ON A. C. A. DYNAMOMETER.

In giving a description of the first public trials of the recently completed dynamometer equipment of the Automobile Club of America, the fact that the first car to undergo a public test was the club's 30-horsepower Pope-Hartford was inadvertently omitted, which was unfortunate in view of the fact that the car made such an excellent showing on its tests. Though this was its first public appearance in this rôle, the club's Pope-Hartford has probably been on the rollers of the dynamometer more than any other single machine, as Dr. Wheeler employed it in breaking the crew that handles the equipment.

### PALMER & SINGER TAKE ON NEW LINES.

Dropping all connection with the Matheson car, the Palmer & Singer Manufacturing Company, of New York, will shortly move into new premises opposite their present quarters, and handle the Simplex car, formerly made by the Smith & Mabley Company. In addition they will market three new P. & S. models, consisting of a four-cylinder 40-horsepower touring car, an elegant town vehicle and a six-cylinder 60-horsepower runabout. The Isotta-Fraschini Import Company, now located at Thirty-third street, will occupy space in the new building of the Palmer & Singer Manufacturing Company, on Broadway.

## HOL-TAN MAKES BENZOL TEST UNDER DIFFICULTIES

A NEW YORK-PHILADELPHIA and return trip by a 25-horsepower Hol-Tan runabout, driven by Joseph Tracy, proved conclusively that benzol was practical as a fuel for automobiles, but failed to give all the scientific data that was expected of the experiment. At 9:30 on Friday morning, January 10, Joseph Tracy introduced himself to



TRACY STARTING FOR PHILADELPHIA ON HOL-TAN BENZOL TEST.

a stock of chest protectors, slipped into his furs, and climbed into the speedy-looking runabout provided by the Hol-Tan company for the test. H. J. De Bear, official observer, occupied the adjoining seat, and when Mechanician V. A. Nielson had started up the motor after a little delay, which might have happened to any gasoline-fed unit on such a cold morning, a start was made for Quaker City.

The object of the test was to ascertain the value of ben-

zol as a substitute for gasoline without any structural changes in the equipment of the car. Benzol, a water-white liquid produced as a bi-product in the manufacture of coal gas, consists of a mixture of benzine, toluene and xylene. It commences to distil at about 176 degrees F. and does not completely distil until nearly 248 degrees F. is reached. Its calorific value is about 20,000 B. T. U. Its specific gravity is about .885 and it contains about 92 per cent. carbon and 8 per cent. hydrogen. As benzol has a higher specific gravity than gasoline and develops more power than the commonly used fuel, it was necessary to have a smaller nozzle and readjust the float. The construction of the Hol-Tan carbureter allowed this to be done merely by adjustment, the car which started out for Philadelphia being thus in all features a standard model.

Seen on his return to New York, Mr. Tracy said:

"We reached Philadelphia with no other trouble than one or two stoppages caused by impurities in our fuel. For some reason or other sand and straw had been allowed to get into the benzol and we had to stop to clean out the obstructions caused by its presence. Otherwise the car ran in a thoroughly satisfactory manner, developing more power than we could have obtained from gasoline. On Saturday morning, when ready to return to New York, we had some difficulty in replenishing our supply of fuel."

An official of the Hol-Tan Company declared that the test had been practically abandoned owing to defective ignition. "For a large portion of the run," he said, "only two cylinders were working, the trouble being with the magneto. On this account we have not been able to get all the data we hoped for, nor to prove anything very conclusive. One thing, however, is certain, the Hol-Tan car is thoroughly capable of running economically on benzol. In order to get more detailed information of a scientific nature, we shall repeat the experiment in the near future."

## ONE MAKER'S PRACTICAL ROAD TEST OF THE "SIX VS. FOUR"

BY GEORGE H. STROUT, SALES MANAGER OF APPERSON BROS. AUTOMOBILE COMPANY.

AS far as my observation goes, it looks as though most makers of six-cylinder cars have produced their new type of engine by adding two more cylinders of the same size as they formerly used in their four-cylinder motors, and, of course, making the necessary mechanical changes to conform to six-cylinder construction and to properly care for the increase in power. Or that they have designed an entirely new six-cylinder motor, without regard to the piston displacement of the four-cylinder motor they had formerly been building. Then, by theoretical, technical and practical tests and deductions they have tried, seriously and honestly, to determine which is the better, the "six" or the "four."

The Apperson method of trying to arrive at the exact facts in the case has varied from the method adopted by other makers. We believe that "the proof of the pudding is in the eating." We believe that both the "six" and the "four" each have advantages not possessed by the other, and it is our purpose and intent to find out, if possible, which of the two possesses the greater advantages, including power, speed, life of motor, cost of maintenance, and repairs. Some factories have turned out four-cylinder motors that have not been practically successful, and it might be "good business" for them to jump into the six-cylinder field.

For some years we have been building a four-cylinder automobile motor, with cylinders of 5 1-2-inch bore and 5-inch

stroke that has been entirely successful and satisfactory to all concerned. I believe that our friends and our competitors will concede that to be a fact. The total piston area of this four-cylinder motor is 95.0334 cubic inches. Many months since we designed and built a six-cylinder motor with 4 1-2-inch bore and 5-inch stroke, total piston area, 95.4261 cubic inches. It will be noted that the total piston area of this six-cylinder motor is only .3927 of a cubic inch greater than the total piston area of our four-cylinder motor. The six-cylinder engine weighs approximately 75 pounds more than the four-cylinder engine, and occupies only 2 1-2 inches more space under the hood. Both engines go into the identically same chassis, and, barring the small additional weight of the "six" engine itself, they must propel the same number of pounds of chassis and body. We have been driving our "six" in competition with the "four" only four or five months, and so we cannot yet arrive at accurate conclusions. We believe each type has its advantages, but right now, although we are building both, we are under the impression that the disadvantages of the "six" outweigh its advantages.

As regards the relative speed that can be made by the "six" and the "four" of equal piston area, we hope to satisfy ourselves on that point at Savannah. While Edgar Apperson will race the four-cylinder "Jackrabbit" at Savannah in March, he will also have, for speed tests, a "six" of the same piston area,



## BRIEF ITEMS OF NEWS AND TRADE MISCELLANY

E. P. Blake, agent for the Jackson and Logan cars in Boston, has leased Horticultural Hall for the purpose of holding his own show during the week of the Boston automobile show, March 7. No admission will be charged.

I. P. Ryland, of the law firm of Ball & Ryland, has been chosen trustee in bankruptcy for the Kansas City Motor Car Company, Kansas City, Mo. Mr. Ryland was the choice of the creditors and will take charge of the plant within a few days.

Extensive alterations and improvements are being made to the factory of the Holsman Automobile Company in Chicago. Additional store space has been obtained and new tools and tool vaults installed with a view to a substantial increase in the output during the coming season.

Comet spark plugs, made by the Oakes & Dow Company, Boston, were used in the Haynes which made a clean score in the Chicago Motor Club endurance run. The makers received a strong testimonial letter from the Haynes factory last week speaking in the highest terms of the Comet plug reliability.

So many offers were received for the "Old English Coach," a 1908 Pope-Toledo creation, that the makers were in a quandary as to who should have it, this being finally settled by its sale to August Busch, vice-president of the Anheuser-Busch Brewing Association, St. Louis. Mr. Busch intends to tour Europe in his new car, which was one of the chief reasons for its purchase.

The Chicago offices of the Indestructible Wheel Company have just been removed to the Auto and Parts Building, 1221 Michigan avenue, where a full line of the steel stampings made by this firm will be kept on display in charge of a competent man. The sales of Indestructible steel wheels since the last Chicago show has been very large and have necessitated improvements at the factory at Lebanon, Ind.

According to E. C. Morse, the new commercial manager of the E. R. Thomas Motor Company, Buffalo, the demand for excess power in a car is greater than ever before, as witness the call of the Thomas 6-70 Special. It was originally the intention of the Thomas company to build but a small number of these cars for special customers, but the demand has increased to such an extent that this plan must necessarily be abandoned, and it is now quite likely that the original estimates for these six-cylinder cars will have to be quadrupled.

### DEATH OF M. L. GOSS.

As the result of what appeared to be a trivial accident at the time, M. L. Goss, secretary of the Baker Motor Vehicle Company, died at his home in Cleveland on Friday night, January 3. On the Monday previous his hat blew off while driving home in the evening and in recovering it he was thrown down by an automobile which collided with him. He was apparently not injured and walked back to his car and drove home. Alarming complications did not set in until the following Thursday, to which Mr.

Goss succumbed the following day. Like so many men who have become prominent in the automobile industry, Mr. Goss was a graduate of both the bicycle and sewing machine lines. He was born in Boston in 1849 and had made his residence in Cleveland ever since 1871, when he entered the employ of the Howe Sewing Machine Company. In 1879 he went with the White Sewing Machine Company, later becoming its secretary, which post he held until 1893. Shortly afterward he became sales manager for H. A. Lozier & Company, and was interested in the wholesaling of bicycles in Cleveland, while later he was associated with the Keating Bicycle Company, at Middletown, Conn. As soon as the electric vehicle became a factor in the automom-



M. L. GOSS.

bile industry, Mr. Goss took it up and has done considerable toward its development since then. In addition to being the secretary of the Baker company, at the time of his death, he was an executive officer of the National Association of Automobile Manufacturers and treasurer of the Association of Electric Vehicle Manufacturers. He leaves a widow and a daughter and son, Ralph H. Goss. The funeral was held at the Wade Memorial Chapel on Monday last, the interment being at Lakeview Cemetery.

### NEW AGENCIES ESTABLISHED.

The Hartford Rubber Works Company has opened a branch at 1817 Boylston street, Boston, Mass.

The South Broad Auto Company, Philadelphia, Pa., has taken the agency for the Kisselkar, made by the Kissel Motor Car Co., Hartford, Wis.

John Van Benschoten, of Poughkeepsie, N. Y., and John H. Bulkley, of Southport, Conn., will represent the Lozier line of cars in their respective districts during the coming year.

Joseph B. McKague Company, 324 Dearborn street, Chicago, Ill., have taken the western agency for the "Englebert" tires and will locate in Michigan as soon as a suitable place can be found.

Stearns cars will be handled in Boston and vicinity by Morgan A. Kent, and new salesrooms will be opened on the corner of Boylston and Gloucester

streets, in the heart of the new automobile row.

The Gordon Auto Supply Company, maker of the well-known Eisner spark coils and Gordon spark plugs, has opened their new store at 1024 Boylston street, Boston, with a full line of sundries. H. Eisner is manager.

G & J tires will be represented in Boston hereafter by the Enterprise Rubber Company, 110 Federal street, Boston. D. B. Price and R. J. Baker, who were formerly with the G & J branch store, will join the selling forces of the new representatives.

Studebaker Bros. Company, of New York, has opened a new branch at 1020 Boylston street, Boston. In connection with the salesrooms, a well-equipped garage and electric charging plant will be maintained. R. W. Daniels is the Boston branch manager.

Among the new agencies recently established by the Forest City Motor Car Company, Massillon, O., for the sale of the Jewel cars, are the following: F. A. Faller, Wilmerding, Pa.; Broad Street Garage Company, Bethlehem, Pa.; Brodess & Company, Decatur, Ill.; C. N. Albright, Akron, O.; D. W. Goble, Monon, Ind.; Ray Wortham Company, Ft. Worth, Tex.

### PERSONAL TRADE MENTION.

Percy Megargel, who has made three trips across the continent in an automobile, is now writing an automobile novel in collaboration with Grace Sartwell Mason, the well-known writer of short stories, and it is said the result of their labors will be the first purely American automobile romance.

Charles S. Henshaw, of Boston, who has handled the Haynes and Thomas product in New England for several years, has disposed of his interest in his Boston retail store, and signed with the Haynes factory to look after the trade exclusively appointing agencies. Boston will be Mr. Henshaw's headquarters, covering New England particularly.

The E. R. Thomas Motor Company, of Buffalo, N. Y., announces the appointment of Fay L. Faurote as advertising manager. Mr. Faurote comes to the Thomas company with five years' experience in the automobile field and will immediately inaugurate an extensive campaign of Thomas advertising, as if it were Mr. Faurote's opinion that the automobile industry is on the eve of one of its most prosperous years.

Arthur N. Jervis, of New York City, the well-known and popular writer, publicity and advertising expert who has been associated with the automobile publicity end for several years past, has found the strain too much for him during the past few months and will consequently go South for a few weeks to take a much-needed rest. Mr. Jervis did much of the active work in connection with the Licensed Show in the Garden last November in addition to his numerous other duties, which are usually more than sufficient to occupy all his time. During his absence, John C. Wetmore and Mr. Jervis' secretary, E. F. Korbel, will look after his interests.

# THE AUTOMOBILE

## WINTER TOURING OVER THE NATIONAL HIGHWAY

By PATHFINDER.

**A**N historian writing in 1901 of the National Highway, remarks: "The era of the National road was succeeded in half a century by that of the railway, and a great thoroughfare, which was the pride and mainstay of a civilization, has almost passed from human recollection." It is a particularly striking example of the impetus given to the good roads movement by the autoing fraternity that to-day, scarcely seven years from the time the above comment was made, the National Highway, far from having "passed from human recollection," has been restored in many places to perfect condition, and in the six States through which the Highway passes its care and improvement are a matter of especial concern to State and county highway commissions. Within the last few years, thanks to the agitation of the automobilists, large sums of money have been expended on the highway, and, although the work of

rehabilitation is far from complete, it now deserves the favorable attention of the tourist who is planning his trips for the coming season. Certain details relating to the Highway, from the automobilist's point of view, as observed by me on a recent trip from New York to Columbus in my White steamer, may therefore prove of interest.

As the National Highway proper commences at Cumberland, Md., the first question presented is: "How does one get to Cumberland?" The tourist should first make his way to Gettysburg, Pa., following one of the routes which I described in an article in *THE AUTOMOBILE* of November 22, 1906. From Gettysburg, the route lies by way of Waynesboro to Hagerstown, this portion of the journey being well described in the April 18 issue of *THE AUTOMOBILE*, in my article relating to return routes from the Jamestown Exposition. Hagerstown, in other ways of com-



TYPICAL STRETCH OF ROAD THAT CONTINUED MILE AFTER MILE ALONG THE FAMOUS OLD NATIONAL HIGHWAY.

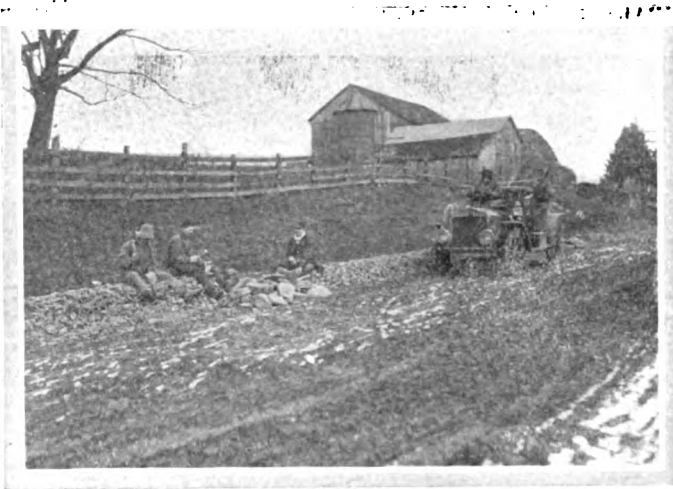

EXAMPLE OF INEFFICIENT LABOR IN ROADS REPAIRING.

paratively little importance, should have a prominent place in every autoist's map. It is the radiating point for routes of the greatest importance—northward to Chambersburg and Gettysburg, eastward to Baltimore and Washington, southward to the Shenandoah Valley, and, finally, westward to Cumberland. Of these several routes, all of them were familiar to me except the last, and it was with no small degree of curiosity that I last week started westward from the square in Hagerstown, having only the faintest idea of what lay before me.

Hardly had we left Hagerstown than we encountered that familiar institution, the toll-gate, which, annoying though it be, is generally an indication of good roads beyond. We found that the toll road extends about thirteen miles, and then enters the mountains. I noted by my speedometer that it was a mile and a half climb to the summit of the first ridge, from which was presented a view of the greatest magnificence, typical of what we were to encounter throughout the rest of our journey. Then came a coast down the mountain of another mile and a half. Thereafter, throughout our journey in Maryland and Pennsylvania, we crossed so many ridges that I lost count of the number of climbs of one, two and three miles and of coasts of equal length. The grades, however, were nowhere excessive—at least, they did not seem so to me, equipped as I was with a power plant of exceptional hill-climbing capabilities.

Twenty miles from Hagerstown we reached the valley of the Potomac River and had a few miles of comparatively level going, passing meanwhile through the town of Han-



LUMBERMAN APPROPRIATED ROAD AS THOUGH HE OWNED IT.

cock, at which point a bridge spans the river and leads to the West Virginia shore. Our road, however, lay straight ahead, and soon we were once more in the mountains and, from that point on to Cumberland (67 miles from Hagerstown), we did not have a hundred feet of level country. It was a case of uphill, then downhill, up and down, up and down. In the section between Hancock and Flintstown (13 miles east of Cumberland) we traversed the poorest section of road on our entire journey. There are no culverts, and in the little valleys the drainage has washed deep channels across the road. The surface is composed entirely of loose stone, and is very hard on tires. Yet it is little wonder that this section of the road has been neglected, since the country is practically uninhabited, and, from the base of one mountain to the base of the next, we would not see a human habitation. At Flintstown commences a fine stretch of road over which, despite the grades, quick time can be made to Cumberland. At this point in the narrative we might pause to inquire briefly into the history of the National Highway.

#### A Bit of National Highway History.

In the first years of the eighteenth century the question of better means of communication between the seaboard States and the growing settlements on and beyond the Ohio



WHITE STEAMER PATHFINDER: "WHERE ARE WE AT?"

River was an important topic of debate in Congress. That body, in 1806, passed a law authorizing the president to appoint "three discreet and disinterested citizens—to lay out a road from Cumberland on the north banks of the Potomac to the Ohio River." In 1808 the work of construction commenced, and in 1818 the road through to Wheeling was open for traffic. It is interesting to note that there was considerable rivalry between Wheeling and Steubenville to secure the western terminus of the highway. Wheeling won out through the influence of Henry Clay, and the successful town later acknowledged their obligation by erecting a statue to that statesman.

#### Progress of the Road Westward 80 Years Ago.

In the period between 1820 and 1833 the road was extended westward by degrees to Zanesville and then to Columbus. About this time, however, the question of further National road improvement became mixed up with the "States' Rights" controversy. Moreover, many members of Congress believed that money would be expended to better advantage in the construction of the new style of highway, the railroad and national aid to good roads came practically to an end. In 1835 Congress ceded those portions of the National Highway which had already been constructed to the

several States. In Indiana the "National Highway" was completed under State supervision, although following the survey previously made by the Federal government. In Illinois the plans of the Federal engineers of a century ago have not yet been entirely consummated. From Cumberland to Wheeling, therefore, is the original National Highway, and, in its early history, it was of much more importance than those portions west of the Ohio river, which were developed at a later date.

#### Highway Has an Individuality.

With this data in mind, we started out on the National Highway and were at once impressed with the fact that it possesses a distinct individuality. From 60 to 80 feet wide, with two and sometimes three lines of telegraph and telephone poles, there is not the slightest chance that the tourist will lose his way between Cumberland and Wheeling. Road directions dealing with forks and turns are superfluous, as the highway at all times completely overshadows the puny little crossroads and forks which at intervals join with it. Then there are the old mile posts of distinctive type, made in pyramidal form and built of heavy iron plates, which, although thick with rust, have nevertheless survived a century of exposure. Then, what local road builders ever laid a road so straight as did the "discreet and disinterested" National Highway Commission! Where the contour of the country permits, the highway is perfectly straight for mile after mile.

In the 30 miles west of Cumberland there is much climbing to be done, until at Keyser's Ridge an elevation of 2,300 and 2,328 feet is obtained, the highest point of the highway. Three miles further the road crosses the State line from Maryland into Pennsylvania. At Petersburg we found a delightful old-fashioned hotel, where we spent the night. And glad we were to seek shelter indoors, for we had encountered conditions which will not be met by those who make the trip in the touring season. The mountains were covered with snow, and in some places were great drifts through which we made our way only by "bucking" and by occasional use of a shovel—a handy part of a tourist's equipment in any season of the year. But even in the sections where the snow had accumulated the deepest, there were occasional spots where the ground was bare, and we had the opportunity to observe that the surface of the road is uniformly excellent for automobiling.

#### Coast Down Mountainside.

The approach to Uniontown is signaled by a coast down the mountainside of more than three miles. At this place the Hotel Titlow well deserves the patronage of tourists. "Allow four and a half hours for the 70 miles to Wheeling," said Mine Host Titlow, an enthusiastic autoist, and



EVEN OHIO HAS SOME TOLL GATES—THIS ONE CHARGED 2 1-2 CENTS PER MILE.

his estimate of the normal touring schedule proved correct. Beyond Uniontown the country flattens out, comparatively speaking; that is, the grades are seldom more than a half mile long, and the hills are sufficiently gentle to permit of the road being laid out perfectly straight for miles.

At Brownsville, 78 miles from Cumberland, the highway takes the shape of a horseshoe, composing the main street of the town. One end of the horseshoe is at the summit of a hill, while the other end is far below, at the old, ramshackle, wooden covered bridge across the Monongahela river. The next town of any size is Washington, Pa., where is located the Washington and Jefferson College. In this town it was necessary for us to note two right-angled turns, but I am inclined to believe that originally the highway passed straight through the town and that local changes in laying out the streets account for these turns. Washington, it may be said in passing, lies almost due south of Pittsburgh, the distance between the two places being only 32 miles.

From Washington it is a ride of but 18 miles to the State line of West Virginia, from which point it is another 16



OLD-TIME TAVERN ON SAVAGE MOUNTAIN, ONCE THE SCENE OF COLONIAL HOSPITALITY.





BRIDGES ARE OF EXCEPTIONAL SOLIDITY, WELL CONSTRUCTED.

miles to the Hotel McLure in the center of Wheeling (136 miles from Cumberland). Although the hills rise up on every side, that portion of the highway which lies in West Virginia is practically level, and, for the most part, is absolutely perfect with no ruts, no holes and no "Thank-yema'ams." Honor to West Virginia! May her sister States emulate her example.

I have reserved for treatment in a special paragraph of condemnation the awful water breaks which we encountered all along our route from Hagerstown to Columbus, except in certain isolated sections. West Virginia is the only State which does not need reproof. It is true that the State Highway Commissioner of Pennsylvania is making efforts, within the limits of his appropriation, to obliterate these relics of a barbaric age, yet much remains to be done within his domain. "Maryland, My Maryland," if there is a tourist who can travel within your fair borders without constant blasphemy, he must be made of different stuff than is the average mortal. Ohio, as regards its eastern counties, is the worst offender, for heavy toll is charged, and the roads should be above reproach. Also, as the country there is more level, there is less excuse for the existence of these water breaks than there is in the mountains. Thirdly, the Ohio water break is a mean, narrow, square-sided affair, much more severe on springs and nerves than the more amply proportioned breaks of Pennsylvania and Maryland.

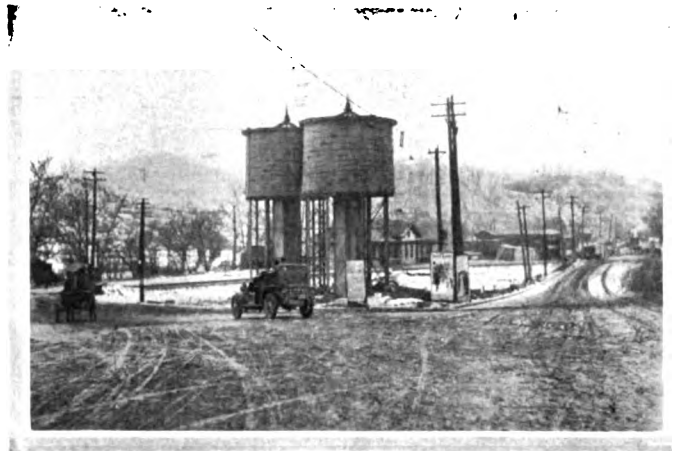

ONLY FORK ON HIGHWAY WHERE ONE CAN GO ASTRAY.

Resuming the narrative—the next stage of our journey carried us from Wheeling to Columbus. There is an island of considerable size in the Ohio river opposite Wheeling, so that two bridges must be crossed before the tourist finds himself in the State of Ohio. In Ohio the iniquitous system of county supervision of highways prevails, with the result that conditions vary from county to county as one crosses the State. In Belmont and Guernsey counties, we paid \$1.48, or at the rate of 2 1-2 cents per mile, for the privilege of passing over roads which, although otherwise excellent, were marred by frequent water breaks. In the next county, Muskingum, no toll is charged, and the roads are of about the same general character. The country here flattens out completely and, in the next county, Licking, commences that remarkable stretch of some 30 miles which leads into Columbus absolutely without a turn. This portion of the road is almost flawless, unless we object to the fact that an interurban trolley road has encroached on about half the original width of the highway. At Columbus, 130 miles from Wheeling, this stage of our journey terminates.

How remarkable has been our 270-mile, one-road tour. Commencing at Cumberland, we have crossed the Alleghenies, have traveled in Maryland, in Pennsylvania, in West Virginia, and in Ohio, and yet we have been but three days on the road since we last saw the Potomac, and we are within five days of "Dear Old Broadway."

## FOUR NATIONS, TEN CARS, TO ATTEMPT NEW YORK PARIS RUN

TEN automobiles, representing four countries, are declared to be ready or in active preparation for the dash from New York to Paris via the Behring Straits. The New York *Times*, which is organizing the contest in connection with the Paris *Matin*, gives the list as follows:

France—De Dion, Motobloc and Sizaire-Naudin.

Italy—Itala and Brixia-Zust.

Germany—Portos.

America—Thomas, Maxwell, Hol-Tan and White.

The German entrant, which is being backed by a Berlin newspaper, will sail direct from Hamburg, instead of Havre, and is due to arrive in New York February 7. The three French cars will leave Paris January 28, traveling under their own power to Rouen and Havre, at which port they will be shipped for New York, arriving here February 8 or 9. Nothing is announced regarding the arrival of the two Italian competitors, the Brixia-Zust and the Itala. The former, a four-cylinder, 40-horsepower car, will be handled by Marquis Boschi, a young Italian nobleman.

Sizaire-Naudin, the makers of a French voiturette which

has had extraordinary success in racing during the past year, will put in the smallest powered car, a little four-cylinder machine rated at 12-horsepower. They have secured as their driver Paul Pons, who mounted a Contal tricar out of Peking and left it to rot and rust on the Gobi desert. De Dion appears to have made very careful preparation and studied the problem of crossing the Arctic regions in a thorough manner. They have the advantage of experience gained by the two machines which successfully covered the entire distance from Peking to Paris.

Not much is heard about the preparation of the four American cars for the round-the-world trip, though if the contest is to be entered into seriously they should certainly be out of the factory three weeks before the start, which is announced for February 15. The Maxwell-Briscoe firm states briefly that its entry will be a stock four-cylinder car with such modifications as are necessary for the trip. It will be handled by W. J. Hanley, the explorer. The Hol-Tan car is declared to be under preparation at St. Louis. Montagu Roberts is spoken of as the driver of the Thomas.

## SAVANNAH'S BIG STOCK CAR ROAD RACES MEET, MARCH 18-19

**M**ARCH 18 and 19 are the dates selected for the big stock car chassis road races of the Savannah Automobile Club, which will be assisted by the special committee from the Racing and Technical boards of the American Automobile Association. The events will be three in number, the principal one being a 360-mile contest over an 18-mile course for the Savannah Challenge trophy. A 150-mile event over a 10-mile course for six-cylinder cars and a similar event for runabouts will be the card for the opening day, the star event being scheduled for Thursday. The course will be one of the fastest in the country, and between 1,200 and 1,500 soldiers will be utilized in its guarding.

The City of Savannah has appointed a special committee to work in conjunction with the Automobile Club, its make-up being very influential in character, and including the following: Mayor George W. Tiedeman, William B. Stillwell, president of the Board of Trade; Wright Hunter, president of the Cotton Exchange; Major W. W. Williamson, president of the Chamber of Commerce; Capt. R. J. Davant, chairman of the City Council and commanding the Chatham Artillery; Frank E. Battey, president of the Savannah Automobile Club and member of the City Council; Arthur W. Solomon, secretary of the Savannah Automobile Club; A. B. Moore, vice-chairman of the County Commissioners; Albert Wyly, chairman of the Chatham County Road Commissioners; Harvey Granger, a prominent member of the Board of Trade, and Jack Rauers, member of the Cotton Exchange and proprietor of the De Soto Hotel.

Two entries have already been made and the fees paid even before the issuing of the entry blanks: Edgar Apperson entering an Apperson, and H. O. Smith coming forward with a Premier.

The rules governing, as promulgated by the special committee, are as follows:

### RULES GOVERNING.

These events are known as Stock Chassis Speed Endurance Contests, open to standard stock car chassis equipped with racing bodies. Conditions governing are as follows:

1.—**Stock Chassis:** To permit of entry under these rules the chassis shall be a standard chassis for the car in the class in which it is entered. Chassis to be eligible shall be so constructed and complete that, without any changes whatsoever, it can, by adding the necessary parts, be assembled into a complete car of its kind. Said car shall be subject to sale at the list price, and orders for any number of exact duplicates shall be accepted at its list price.

2.—**Eligibility:** Cars eligible for entry must be the product of a recognized motor car manufacturer, who, during the period of one year prior to February 1, 1908, shall have built not less than fifty cars of all models, of which not less than 10 per cent. shall have been manufactured of any model entered, and details of construction must conform to those of the regular stock chassis of the same model or models.

3.—**Stripping:** The chassis may be stripped of lamps, lamp brackets, mud guards, guard irons, running board, irons and steps, but must carry the regular stock hood. The loss of the hood during the race shall have the effect of disqualifying the car.

4.—**Examination:** Every car entered in these contests shall be subject to a detailed examination by a committee of three members of the Technical Board of the American Automobile Association,

for the purpose of seeing that no evasions of these rules have been attempted. This examination shall be at headquarters on the course not later than three days prior to starting in a contest, and if it is found that evasions have been made or attempted, the car shall be disqualified and shall not be allowed to start. There shall be no appeal from the decision of the committee, and entry fee shall be forfeited, and manufacturer and driver shall be barred from future events for such period as the Racing Board may decide.

5.—**Regular Equipment:** Location of engine, transmission, and dash, and location and capacity of gasoline tank and oiler shall be as per regular equipment.

6.—**Steering Column:** Location and angle of steering wheel shall be standard, using standard steering column, gear wheel, and all steering connections.

7.—**Tires:** Kind of tires to be used are optional with the entrant, except diameter of wheels, which shall be standard.

8.—**Speed Qualifications:** Any car to qualify for entry under these rules must show that it is able to make one mile over a substantially straight measured course, under official observation, at the rate of 45 miles per hour. A car may run in either direction on this measured mile. Each entrant is to be given ample opportunity to qualify, but must do so in not to exceed four trials. The officials mentioned in Article 4 are to decide whether the car is eligible for entry or not. Entry fee is to be forfeited in case the car fails to qualify in this trial.

9.—**Tread:** The tread of cars in any contest held under these rules will be that regularly employed as standard by the manufacturer entering the car.

10.—**Exhaust:** Cars shall have a horizontal exhaust pointing backwards and having its rear end sufficiently high to prevent throwing up dust. Should the entrant elect to direct the exhaust through the side of the hood, he is to be given this option.

11.—**Weight:** No limit.

12.—**Shock Absorbers:** The entrant has privilege of using same.

13.—**Ratio of Gear:** No restriction.

14.—**Change of Driver:** The driver or mechanic (or both) of a car may be changed, if necessary, during the contest.

15.—**Repairs and Adjustments:** All repairs and adjustments, including tire replacements, are to be made on running time, and by the occupants of the car.

16.—**Extra Parts:** No extra parts are to be carried on cars, except tires.

17.—**Supplies:** Gasoline, oil, and water are to be provided by each contestant, the location of whose replenishing station or stations will be designated by the Race Committee, or subject to its approval. Filling of gasoline and oil tanks by outside help will be permissible.

19.—**Event No. 1.**—No car shall be entered which has a greater maximum piston displacement than 575 cubic inches. Distance of this race shall be 20 laps of the 18-mile course, or approximately 360 miles. The entry fee shall be \$500 for one car and \$250 for an additional car nominated by the same entrant. Any manufacturer may enter two cars.

20.—**Event No. 2.**—No car shall be entered which has a greater maximum piston displacement than 375 cubic inches. Distance of this race shall be 15 circuits of the 10-mile course. The entry fee shall be \$100, and each manufacturer may enter two cars.

21.—**Event No. 3.**—Open to cars with a greater maximum piston displacement than 575 cubic inches. Distance of this race shall be 15 circuits of the 10-mile course. The entry fee shall be \$100, and each manufacturer may enter two cars.

22.—**Date for Closing of Entries:** March 1, 1908.

23.—**Right to Reject:** The committee reserves the right to reject without assigning a reason.

24.—**Protests:** Any protest must be made in writing to the referee and accompanied by a fee of \$50, which will be returned if the protest is sustained. Such protest, if for violation of rules during the race, must be made within 12 hours of the alleged violation. Protest regarding an entry must be made not later than 24 hours before the start of the race.

25.—**Manufacturer's Sanction:** No entry shall be accepted in the name of any other than the bonafide manufacturer of the car without the written sanction of the manufacturer thereof, and his statement acknowledging familiarity with the conditions governing the contest and his assumption of all responsibility for failure on the part of the entrant or his representative to fully comply with the said rules.

26.—**A. A. A. Racing Rules:** Except as hereinbefore specified, the races will be governed by the regular rules of the Racing Board of the American Automobile Association.

## RUNABOUT CONTEST TO PRECEDE FRENCH GRAND PRIX

**P**ARIS, Jan. 13.—There will be two days' racing in connection with the French Grand Prix held the first fortnight in July. The day preceding the appearance of the powerful racers a voiturette or small runabout race will be held over the same course under a limited bore rule which will probably be 100 millimeters for single-cylinder engine and 80 millimeters for two-cylinder motors. Entry fee will be fixed at \$200 for one car, \$350 for two cars and \$400 for a complete team of three. Complete regulations have not yet been compiled, but will probably be those of the very successful voiturette contest of last October.

No changes have been made in the Grand Prix regulations adopted by the Racing Board and now approved by the full club committee. Maximum bore is 155 millimeters for four-cylinder engines, distance will be 430 to 500 miles, three cars per firm, and all work to be done by the driver and his mechanic. If the number of engagements makes it necessary, an elimination race will be held over the same circuit, but for only half the distance covered in the final. Engagements at ordinary fees will close on February 15; at double fees on June 1. Tire or gasoline firms desiring stations on the course must put in their applications by the same dates

and pay a fee of \$200. All stations must be grouped at two points on the course, one of which will be opposite the grandstand. Though dismountable rims can be used, it is forbidden to change a wheel, and the use of oxygen or any addition to the gasoline is contrary to rules. The racing colors for cars of each nation are as last year.

No choice of a circuit has yet been made, the Racing Board refusing to give any information on this matter. Dieppe offers a subvention of \$10,000 if two-days races are held and one other town guarantees to raise \$20,000 to have the contest in its district. It is necessary to maintain secrecy on the courses which are under consideration, the exactions of the natives being such that immediately there is a possibility of their district being selected for the race land along the course increases in hiring value far above what it would cost to buy it outright under ordinary conditions.

**Two-cycle Engines Favored in Grand Prix.**

PARIS, Jan. 14.—There is a unique opportunity for builders of two-cycle motors in the French Grand Prix, but whether any makers of this type of engine will rise to the occasion is doubtful. The Ostend conference, which drew up the international rules, fixed a maximum bore of 155 millimeters for four-cylinder engines, leaving conditions for all other types to be worked out later. After the matter had been thoroughly discussed by the Racing Board of the French club, it was decided to allow two-cycle engines to have the same bore as those of the standard type, although this would obviously give them an advantage.

René de Knyff, chairman of the board, in discussing the rules, said: "We have certainly favored the two-cycle engine by allowing it to have the same bore as the four-cycle type, but we want to help the two-cycle to prove what it is capable of doing. It is not yet commonly employed and we did not wish, by severe regulations, to make its struggle for favor too difficult. If it is capable of doing anything, there is a chance now for it to prove its power. We shall then have some practical experience, together with laboratory tests, to enable us to fix a more equitable racing rule."

Though a good deal of attention has been paid in France during the past two years to motors of the two-cycle type, few of the firms building this class of engine are in a financial position which would justify them in expending the money necessary to compete in the Grand Prix race. Peugeot is the only powerful concern having produced a satisfactory two-cycle engine, and it has been suggested that they build an eight-cylinder two-cycle racer. For an eight-cylinder engine they are allowed a bore of 110 millimeters, this alone being more advantageous than 155 millimeters for a four-cylinder engine; combining the two would enable a very much more powerful motor to be built, providing the two-cycle type is all that its supporters claim, and would bring it before the public as no amount of private demonstration could.

**RULES FOR O'GORMAN NON-RESTRICTION RACE.**

LONDON, Jan. 13.—Mervyn O'Gorman was of opinion when international racing rules were adopted that much might be learned from races between cars absolutely unfettered by any bore, stroke, and weight restrictions, and offered a trophy to be competed for on that basis. Rules of the race, just published, provide for the competition to be held between cars of any nation, any power or any type, providing they are wholly mechanical, between May 1 and July 31. Brooklands track will be the place of contest, and distance must be not less than 100 miles. All arrangements for the holding of the race are to be in the hands of the Brooklands authorities, who shall have the power to charge an entrance fee, but must allow the winner to compete free in the next annual contest.

**MUST POLICE WESTCHESTER COURSE WELL.**

"The Westchester course, selected for the stock chassis race on April 24, is far more sporty than the Vanderbilt circuit of 1905 and 1906, and is a route well calculated to test the skill of the drivers no less than the running qualities and speed of the cars," declares C. V. Redden, manager of the automobile department of the Studebaker Company, of New York.

Mr. Redden, who went over the entire course on a Studebaker roadster, declares: "To make this event an absolute success, it is essential that the course be properly policed. There are a number of cross and intersecting roads which, without an efficient policing system, would make fast driving almost impossible. In fact, upon the proper policing of the course depends to a great extent the success of the race. All who attended the last cup race held on Long Island saw how utterly impossible it was to control the

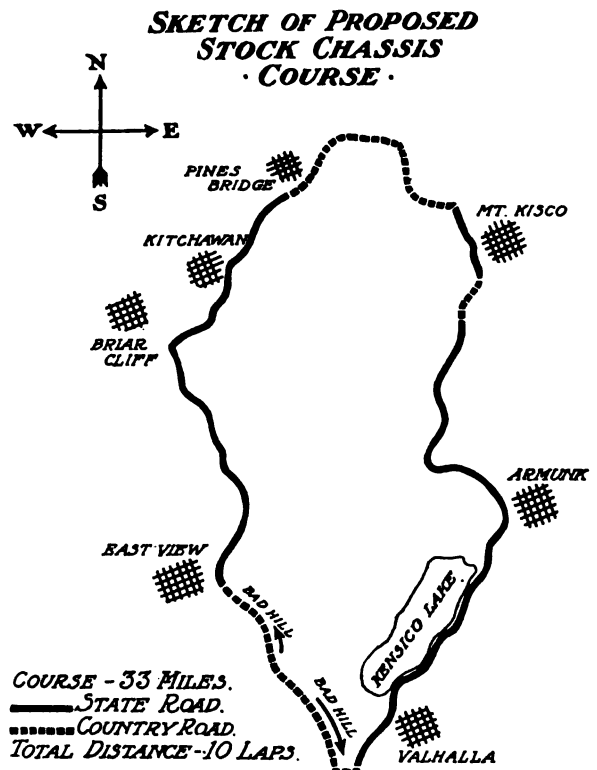

crowds. It should be remembered, too, that this course is not isolated, but can be easily reached by three different railroads as well as by trolley. The road is generally wide enough for two cars to pass, but I believe that absolute reliability rather than excessive speed will win the race. The ability to get under way after rounding a corner will be an important factor, and the long wheelbase car will be at a disadvantage. From Pine Bridge to Mount Kisco the roads are poor, and from Valhalla back to East View the course leads over a road which is really hilly and will test drivers and machines."

**ICEBOAT AND AUTO MAY TEST SPEED.**

MONROE, MICH., Jan. 13.—Commodore W. C. Sterling, of the Monroe Yacht Club, and an enthusiastic motorist, holds to the belief that the auto is able to lay it over an iceboat when it comes to speed, and has issued a challenge that promises an innovation in sports. Commodore Sterling wants to race any or all Detroit and Toledo ice yachtsmen, and is willing to wager that he can beat them with his auto on a straightaway three-mile course before the wind. Several yachtsmen have expressed a determination to take the Commodore up, and the outcome will be interesting.

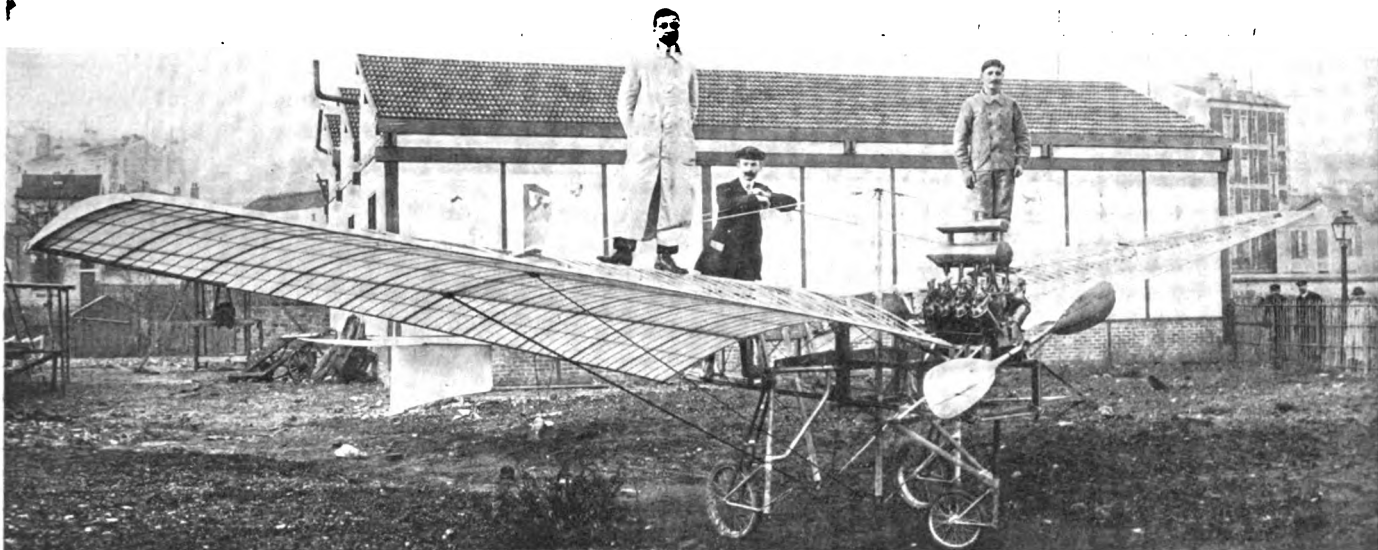

STEEL-RIBBED AEROPLANE, THE LATEST ASPIRANT FOR FLYING HONORS, ON THE TRAINING GROUND NEAR PARIS.

### ANOTHER ASPIRANT FOR AEROPLANE HONORS.

Still another aeroplane has been added to the aerial fleet around Paris. The newcomer, built for M. Gastambide and Mengin, is a business-like looking apparatus, in strong contrast to some of the crude and poorly constructed machines to be seen on the testing ground. It is of the monoplane type, with engine mounted in the center, and a three-wheel chassis underneath built up with a certain amount of play to allow for shocks when alighting on the ground. An example of the strength of the wings, 32 feet from tip to tip, was shown on the first day out, when a man stood on the middle of each without any damage being done. The system employed in building up the wings is by means of a framework of thin steel ribs, covered with canvas, each wing fitting into grooves on the chassis of the aeroplane in order to be easily dismantled. The motive power is an eight-cylinder Antoinette motor in V, with a two-bladed aluminum propeller mounted direct on a forward extension of the crankshaft. There is no raising or lowering helm, the constructor believing that the motor is sufficiently supple to give the necessary range of altitude by variation of its speed. Total weight of the machine ready for running is 880 pounds. It is calculated that it will leave the ground when a speed of 34 miles an hour is attained.

### TWO THOUSAND DOLLARS FOR 15-MINUTE FLY.

PARIS, Jan. 13.—Two thousand dollars can be earned in fifteen minutes. The only conditions are that an aeronaut mounted on a heavier-than-air machine shall remain in the air for fifteen minutes and be officially controlled by a committee appointed by the Aero Club of France. On his descent he will be handed the cash prize offered by M. Armenguad, president of the French Aerial Navigation Society. The record is now held by Henry Farman, with three minutes aloft on an aeroplane. The new competition will be open until the end of 1908.

### PILOTS WILL GO SKYWARD FROM CANTON.

CANTON, O., Jan. 20.—Arrangements have been made by the Aero Club of Ohio for a second balloon ascension here towards the end of this week. It is announced that Lieutenant Lahm will come from Washington to make an ascent if the weather is favorable. President Sherrick, of the Aero Club of Ohio, will probably make an ascension with the balloon Ohio.

### FARMAN REMAINS THREE MINUTES IN AIR.

PARIS, Jan. 15.—As if to prove that his winning of the Deutsch-Archdeacon prize for the flight of a kilometer in a closed circle was no mere stroke of good luck, Henry Farman to-day remained three minutes in the air and covered a flight of two kilometers, or 1.2 miles. He began his day's work on the Issy-les-Moulineaux ground with a load of 66 pounds attached to his aeroplane, but found that very slight lifting movement could be obtained. When the load had been reduced to 44 pounds the machine rose into the air and traveled a short distance, but appeared to possess no life.

A 33-pound load was then attached, and the machine driven right across the drill ground to the walls of the fortifications, where a sudden squall struck it and for a moment appeared likely to cause a disaster. Farman was obliged to suddenly turn at right angles, but his machine responded wonderfully, and another run was made on an even keel to the opposite end of the ground, distance from the earth not being more than a yard or a yard and a half.

For the final test all weight was removed, the machine being in exactly the same condition as when it competed for the \$10,000 prize. Starting on the edge of the ground nearest the river, after 50 yards had been covered the aeroplane rose into the air and made for the Porte de Sèvres. Here a turn was made and a vast circular flight begun close to the fortifications. Almost a mile and a quarter was covered before Farman brought his flyer down at the door of the shed, thus accomplishing the longest flight yet recorded for a heavier-than-air machine.

### BIG AERO PROGRAM FOR WINDY CITY.

CHICAGO, Jan. 20.—Five handsome trophies and medals and \$10,000 in cash will be offered by the Chicago Aeronautique Club at its national contests to be held here July 2-4. Most important among the seven events on the program is the international race for a \$200 trophy to go to the man who covers the greatest distance; \$200 will go to the aeronaut remaining the greatest length of time in the air. The number of starters is limited to 30. Two prizes are offered for the greatest distance covered in five hours in the single-passenger test, without limitation as to size of balloon. There will be the same number of prizes for the dirigible balloon contest over a course of five miles and return.

Event number four will be a contest between aeroplanes and man lifting kites, the distance to be 1,500 feet.



## WHY NOT A GREAT HIGHWAY ALONG THE ERIE CANAL?

FOR a State of its wealth and population, New York is probably more backward where the condition of its highways is concerned than any commonwealth of its size. In view of this fact, the suggestion just put forth to utilize either the tow-path of the old Erie Canal, or the very bed of the canal itself, as the foundation of a great trans-state highway, is particularly appropriate. New York has already appropriated \$50,000,000 to carry on the work of road betterment, but in the interval of a year or so that has elapsed since this has been made no great progress has been accomplished, and it would seem that a substantial part of this appropriation could hardly be used to better purpose than that suggested. In the tow-path there is to be found the basis of a broad highway 325 miles in length, and passing through the majority of the State's centers of population which scarcely needs more than broadening for its realization, while the bed of the canal itself represents a perfectly level stretch of the same length that could be readily converted into a road that would be without an equal anywhere.

When interviewed for the New York *Herald*, State Superintendent of Public Works Frederick C. Stevens was enthusiastic over the project. "I have looked carefully over the proposal to convert the Erie Canal into a great trans-state highway," he said, "and have discussed the plan with legislators, good roads advocates, and engineers. I believe the plan is an excellent one, and believe it should be brought to the attention of our lawmakers, roadmakers, and the public, which is interested in obtaining good and continuous highway facilities."

It would be a comparatively simple matter to either widen the present tow-path, or by filling in the bed of the canal itself create a great highway across the State that would be of vast benefit. In view of the fact that taking advantage of the tremendous amount of work already done would eliminate all preliminary surveys and engineering expense of kindred nature, the cost would be less than half that required to build a new road, and it could doubtless be taken care of under the new plan by which the State pays half and the county through which the road passes pays the remainder. It may be added here that the majority of the counties through which the canal passes are notorious for their poor roads. At present there is a law prohibiting the

use of the tow-path by vehicles other than the time-honored mules which dragged the canal boats across the State from Albany to Buffalo for more than half a century, but that could easily be repealed.

The details of the plan already worked out by Mr. Stevens have reference to the tow-path alone, and in speaking of it he said: "There are many portions of the tow-path that are already wide enough, and all of it could readily be utilized as the foundation of a continuous road. In places the path is more than 30 feet in width, while the narrowest average 15 feet or over. It would be necessary to grade some of the approaches, but nowhere would the engineering problem to be solved be of a serious nature."

As the tow-path has been continuously trodden down by the feet of countless mules for the past seventy years, it will be evident that all this needs to make an excellent road of it as it now stands is a little more width. The total difference in level between Albany and Buffalo is said to be slightly less than 400 feet, there being one stretch of 59 miles just west of Utica, known as "long level," that is without a break of any kind, and is probably unique in such country as upper New York State. In addition to this, the canal is in a great many instances the most direct route between cities that it joins. Between Ilion and Utica, for instance, there is an almost straight and absolutely level stretch of 11 miles, which can be covered in a car in a few minutes, whereas by the road the distance is almost double, and the going is not alone poor, but hilly.

It is, indeed, difficult to conceive of the inestimable benefit that the carrying out of such a project would be to New York State as a whole. The opening of the Erie Canal, the better part of a century since, was described as an epoch-making event in the history of the State, and it is generally conceded that its existence has been one of the greatest single factors in New York's development. In its way, the opening of a road, either paralleling or taking its place, would be an event of no less importance, as apart from the unequalled means of communication it would afford, not alone between the various up-State cities, but clear across the State, it would also furnish an example that could not fail to be taken advantage of by other communities, thus giving a tremendous impetus to the cause of good roads.

## LATEST PROPOSITION FOR NATIONAL AID IN ROADS BUILDING

WASHINGTON, D. C., Jan. 21.—That the good roads movement has many friends in Congress is evidenced by the number of bills that have already been introduced looking to the improvement of the national highways. The latest one is fathered by Representative Ferris, and its object is to provide for a permanent, lasting and uniform system of improvement of public highways and post roads by having the State and nation act in conjunction and by mutual contribution bring about the desired end. The further object of the bill is to distribute the surplus in the treasury pro rata each year among the States for that purpose.

The bill provides that it shall be the duty of the Secretary of the Treasury, with the approval of the Secretary of Agriculture, at the close of each fiscal year, to determine the amount of surplus in the United States Treasury, after making all necessary deductions for all expenses and amounts that by law shall remain on deposit in the Treasury, the remainder to be deemed and declared a surplus and available

for distribution among the States and Territories. This surplus is to be distributed at the rate not to exceed one-half million dollars yearly to each State and Territory.

The provision is made that no State or Territory shall receive any of this surplus until it has furnished satisfactory proof that it is willing, ready, and has the ability to pay an equal amount to the aid received under the proposed law. Various other provisions for carrying the law into effect are set forth in the bill, which was referred to the Ways and Means Committee for action and report. Many of the representatives, particularly those from the Western States, are taking more interest in the cause of good roads than has ever been noticed before, and if this interest is properly fostered, in the course of the next year or two, all the legislation that even the most enthusiastic advocate of road improvement could wish for should be forthcoming without great difficulty. But to do this it will be necessary that every autoist interest himself personally in the work.

## RIGID CONDITIONS FOR 1908 PRINCE HENRY TOUR

**B**ERLIN, Jan. 15.—The propositions for the Prince Henry Tour, the chief German event in 1908, have now been issued by the Imperial Automobile Club, and in the principal points run as follows:

The Prince Henry Tour is an international reliability trial.

It is open to cars of four and six cylinders, with a total piston surface of 227 to 679 square centimeters, equivalent to a bore of 85 to 146.5 for four and 69.5 to 120 millimeters for six-cylinders.

The cars must be owned by members of recognized clubs and must have been previously driven at least 2,000 kilometers.

The total weight of the car of 227 square centimeters, piston surface, must be at least 860 kilograms, exclusive of spare tires, tubes, and with empty tool box, the fuel excluded in this weight (petrol, water, oil) may not weigh more than 60 kilograms. For every square centimeter more piston surface, the weight is increased by 11.4 kilograms.

No alteration in weight may be made during the tour or missing weight be replaced by ballast.

Every car must be provided with a speedometer.

Cars driven by petrol of the specific gravity of 680 and upwards, benzol, and alcohol and their mixtures, are eligible to compete.

The cars must be driven by men who are members of the corporations named above and who receive no equivalent for driving.

Entries must be made by the car owners at the secretarial offices of the Imperial Automobile Club, and must be accompanied by a fee of 400 marks, as well as the certificate of cylinder dimensions.

Entries close on April 1 at 6 P. M.; entries at double fees will be received up to May 1, 1908. Should less than fifty entries be received, the club reserves the right of not promoting the tour; on the other hand, it has the right of limiting the entries.

The tour takes place from June 9 to 17; the weighing-in of the cars takes place on June 7 and 8. The daily stages are:

Tuesday,	June 9,	Berlin to Danzig.
Wednesday,	" 10,	Danzig to Stettin.
Thursday,	" 11,	Stettin to Kiel.
Friday,	" 12,	Rest at Kiel.
Saturday,	" 13,	Kiel to Hamburg.

(Speed trials between Rendsburg and Itzehoe on the flat.)

Sunday,	" 14,	Rest and exhibition of cars at Hamburg.
Monday,	" 15,	Hamburg to Cologne.
Tuesday,	" 16,	Cologne to Trier.
Wednesday,	" 17,	Trier to Frankfurt.

(Hill climb between Trier and Frankfurt. The start takes

places in the consecutive order arranged by the club, once for all, the most consecutive cars, No. 1 leading off first daily.)

Each car must carry at least three grown-up persons, including the official observer, during the tour, and four during the speed trials. In lieu of a fourth person, 70 kilos of ballast must be carried. All repairs during the tour may only be carried out by the driver, chauffeur, or a person nominated as such. Every repair, even though the car be in motion, will be debited with minus points.

A period of sixty minutes before the start is permitted for all necessary repairs and adjustments, taking in of fuel, oil and water, exclusive of changing tires. The valuation will take place as follows: Every commenced minute of an involuntary stop necessitated by the car or any parts will be debited 2-10 points, likewise every commenced minute during which repairs are made while the car is in motion. Repairs of speedometers will be booked but not debited. Any time taken up by repairs before the start and exceeding the sixty minutes allowed will also be debited as above. Regulations concerning the tires will follow later. After the start the taking in of cooling and brake water will be debited with 5-10 points. During the day it is only permitted to take up fuel and oil, but no water, at the dinner stations to be made known.

The speed trials will be rated according to the table yet to be published, in as much as should the car not attain or exceed the speed fixed for it as normal, it will be debited or credited for every commenced 1-10 per cent., 1-100 point on the flat, and 1-200 point on the hill climb. Should equal points be attained on the hill climb, the speed trial results will be taken into consideration and vice-versa. A ballot will decide in the second place. A competing car with more than 12 points loses rights for a prize in the speed trials.

Victor is he whose car possesses the best number of points; equal points will be decided by the flat trials result, or the hill climb.

The Prince Henry prize, a challenge trophy given by H. R. H. Prince Henry of Prussia, becomes definite property if won twice, if not the ballot will decide between all three winners.

Up to the present, the following further prizes have been presented for 1908: By H. R. H., the Grand Duke of Hesse, for the hill climb; H. R. H., the Princess Henry of Prussia, for the speed trials; H. R. H., the Hereditary Princess of Saxe-Meiningen; the City of Lubeck. All cars completing the tour without debit points will receive a diploma.

Other particulars will be forwarded by the Imperial Automobile Club, Leipziger Platz, 16, Berlin, Germany.

## LIGHT EXPRESS VANS AND EIGHT-CENTS-A-MILE TAXICABS

**P**ARIS, Jan. 6.—In addition to the commercial vehicle contest to be held during the summer by the Automobile Club of France, a separate competition will be held in Paris and the neighborhood at the end of February or early in March for small commercial vehicles. How small they will be is shown by the fact that some of the classes will be for cabs with provision for two passengers only and not capable of exceeding eighteen miles an hour. The intention of the organizers is to produce a vehicle which will be a direct rival of the light two-passenger horse cab now familiar to all Parisians, and to develop a cheap, easily maintained commercial vehicle, which can be adopted by business houses of moderate size.

There are four classes of passenger carrying commercial vehicles, the largest being a six or seven-passenger omnibus for work between railroad depots and hotels, capable of carrying, in addition to its human load, 80 pounds of baggage per passenger. This is a type of vehicle already maintained by a number of hotels and railroad companies. Another class is for four-passenger cabs capable of taking in addition 350 pounds of baggage. High-class landaulets with provision for four passengers, without baggage, forms class three, and the last category is for small two-passenger cabs of not more than 12 horsepower and not exceeding 18 miles an hour on the level. Vehicles of this class are not called

upon to carry a registration number. Each category in the competition, which is designed specially to meet local conditions, aims at supplanting some special service now performed by horse vehicles.

Commercial vehicles carrying goods comprise motorcycles capable of taking a load of 100 to 200 pounds, small automobiles built to carry a 1,200-pound load, and larger cars for not more than 2,500 pound loads. Stringent regulations will prevent two-ton trucks taking up the maximum load of 2,500 pounds. The object here is to produce a vehicle which will tackle the horse on its own ground, which will be light, cheap, easy to keep and simple to operate.

In this connection Marquis De Dion, who ought to know what he is talking about, proposes to put on the streets a series of automobile taximeter cabs to work at the rate of five cents a kilometer, which is equal to the munificent figure of eight cents a mile. Such a scheme, if it were put into execution, would make taxicab riding the cheapest known form of locomotion, and would put buses and trolley cars entirely out of business. The Marquis brings forth figures to prove that his scheme is practicable. His vehicle would be built as light as possible, would consume little fuel, would run at ten miles an hour, work ten hours a day, and last three to five years. It would pay its driver two dollars a day, plus tips, and would cost \$900 to build in quantities.

## ROYAL AUTOMOBILE CLUB AND MOTOR UNION DISAGREE

LONDON, Jan. 13.—There is a struggle for supreme control in official automobile Britain, which is not likely to end until one of the two parties engaged is wiped out of existence. The mere fact that those particularly concerned deny any bellicose intentions does not diminish the interest in the blows being given or lessen the ardor of the respective supporters of the Royal Automobile Club of Great Britain and Ireland and the Motor Union.

On the one side is the aristocratic, dignified, select Royal Automobile Club, the embodiment of British prestige, and on the other the youthful, vigorous, pushful Motor Union, strong in hope and promise.

Eight years ago the Automobile Club of Great Britain and Ireland, not then risen to the dizzy heights of royalty, absorbed an automobilists' defense association, and changed its name to the Motor Union. Its sphere of usefulness was restricted to carrying out the work previously entrusted to the Competitions Committee, and to relieving the recognized authority of some of the burden of work carried out by it for the general advancement of automobilism. There was to be no social life for the Motor Union and no interference with the club's recognized position as the automobile authority.

Early in 1904 the provincial clubs, seeing little personal benefit in the aristocratic body with headquarters in Piccadilly, put forth a scheme of federation which threatened to leave the recognized authority a mere gilded figurehead. There was a call to head off the malcontents; the Motor Union was reconstructed on democratic lines, and accepted by the provincials in place of the proposed federation. While remaining under the thumb of the Automobile Club, the Union was to advance the automobile movement in the United Kingdom, and to "extend the facilities for touring by mechanically propelled vehicles."

Three years passed and the Motor Union had grown in membership from 5,865 to nearly twenty thousand, while the more select Automobile Club had only increased its numbers by a little more than a thousand, and could not muster more than 3,375 all told.

With the growth in numbers had been a corresponding increase in activity, the Motor Union extending its operations to other fields, entering into schemes which the national club

with its royal connections did not look upon as becoming or proper, and finally had the effrontery to challenge its royal parent on its own ground. After several months of strained relations the "recognized authority" served notice on the active, youthful partner to terminate the agreement.

There were thus two bodies, one asking for the support of the provincial clubs as a king would command the respect of his subjects, the other arguing and acting with all the enthusiasm and force of a Radical candidate at election times.

The Motor Union first put out its program, offering to automobilists throughout the country legal advice and support in case of prosecution, touring facilities at home and abroad, a weekly journal, handbooks, engineering advice, a club badge, the service of scouts on the road, a central office in London, a complete library, clubrooms in two provincial centers, and special arrangements with hotels. As even an unlimited amount of prestige could not, alone, serve to attract provincial clubs, the Royal Automobile Club a few days later issued its manifesto in the form of an associate membership scheme, the associate members to have practically all that the young rival offered, and to be given all that full club members obtained with the exception of admittance to the social life of the Royal club.

The question is whether the provincial clubs will follow the lead of the Royal Automobile Club or go under the banner of the Motor Union, which has for the past few years been most intimately connected with their existence. There is little to choose between the programs. On both sides there are promises, possible of realization, which at present exist on paper only. The subscription for individuals or per head of club membership is the same for Royal club and Union, but the club proposes paying back to the county or district club a sum of five shillings per head in recognition of their local work for the benefit of motoring. Thus every person joining the Royal Automobile Club as an associate member strengthens the finances of his local club.

Already Nottingham has decided to quit the Union in favor of association with the Royal body. The Union, however, has by far the stronger position with the provincial clubs, and, if able to maintain their support, will seriously imperil the existence of the Royal Automobile Club.

## INTERNATIONAL AUTO CLUBS TO PAY DUES PER MEMBER

DELEGATES at the last meeting of the International Association of Recognized Automobile Clubs, held in Paris on November 21, 1907, voted that a subscription of fifty centimes per member per annum should be imposed on all clubs, according to the minutes of the proceedings, which have just been made public. Count de Sierstorpf, the German delegate, proposed a scale of subscription at the rate of one franc per member. Baron de Zuylen, on behalf of the Automobile Club of France, put in the counter motion to the effect that the amount should be fifty centimes per member for the first year, the dues to be paid yearly by January 31.

According to the official report of the meeting, the two American foreign representatives, Messrs J. Howard Johnston and W. S. Hogan, were present at the meeting. No communication was made to the press after the meeting, but those members who gave a hint to journalists as to what had happened, declared that the United States was not represented by its A. C. A. delegates.

Although the International Association has been in existence since 1904, it has not yet had any regulations. The fol-

lowing four clauses were therefore agreed to and ordered to be sent to all interested clubs for expressions of opinion before being brought up for adoption at the next conference:

I. The limitation of the power of the Administrative Council, on which each club represented should only have one delegate in addition to the treasurer, and should only exercise one vote.

II. The quorum necessary for the validity of the votes of the general meetings, fixed at four-fifths of the clubs represented.

III. The basis upon which the subscription from the clubs be calculated.

IV. The addition of a clause providing for the summoning of an extraordinary general meeting on the request of at least five clubs.

In the discussion which followed on racing and touring conditions, it appeared to be understood that the 155-millimeter rule adopted at Ostend was only intended for such big events as the Grand Prix, Ardennes Circuit, Taunus, and Brescia circuits. One of the Italian delegates wished to arrive at a formula for touring cars similar to that adopted for racers at the Ostend Conference, and Mervyn O'Gorman, of England, moved in favor of the adoption by manufacturers of a rating which would more correctly indicate horsepower than the present description.

## LETTERS INTERESTING AND INSTRUCTIVE

### WHAT IS THE CAUSE OF THIS TROUBLE?

Editor THE AUTOMOBILE:

[1,113.]—I have been using for the past year a Ford runabout which has given entire satisfaction until about a week ago. I went out for a run, and as I got started the engine suddenly stopped, and on moving my spark advance lever, I could not get any buzz, as is customary from the coil. The engine seemed perfectly dead, and when I would crank it it would give one or two explosions and there would be no spark as before. I then very carefully went over all the wiring, looked at all terminals, which were all O. K., but still I got no spark, and did not get one even after I had put entirely new wires from both poles of my storage battery, which is a Vivax 6 volt 50 ampere hour one. Then I went all over my plugs and high-tension wiring, which is good. After fooling for some time, the vibrator suddenly started to buzz and the car went all right for the rest of the day, but balked the same way on the following day. I then completely rewired it, high and low tension, put in a freshly charged storage battery, cleaned the timer thoroughly, and then tried her out. As long as the throttle was closed she would go fine, but as soon as it was opened she would miss a great deal and not respond at all. I have a dash regulator for my carbureter and tried every conceivable way to adjust it, but I could not remedy the trouble, and I have written to you, thinking you might be able to help me out by some information through your "Letters Interesting and Instructive."

J. S. WEBB.

Shovan Hill, Pa.

The cause of the first trouble was evidently a short circuit or an open circuit in some part of the ignition system, which accidentally remedied itself, as is not infrequently the case, by the wire coming away from whatever it may have been touching, or by the two ends of a broken wire or poor connection coming together again through movement of the car, or similar cause. We should think that the general overhauling which you gave the ignition system on the second day would have effectually remedied any trouble there. Failure to pick up on opening the throttle with consequent missing, is very often due to faulty working of the auxiliary air valve of the carbureter. Another cause is a leak in the intake manifold or similar point, permitting an excess of air the moment the motor speeds up a bit and thus destroying the uniformity of the fuel mixture. This is one of the most puzzling ailments that the gasoline motor is heir to, and it is a difficult matter to diagnose such a case at long range. If any of the readers of this column have suggestions to offer from their store of personal experience in overcoming just such things as this, we should be glad to hear from them.

### DETAILS OF A HOME-MADE, AIR-COOLED ENGINE.

Editor THE AUTOMOBILE:

[1,114.]—Will you kindly tell me in your next issue what you think of a four-cylinder air-cooled high-speed engine? I am designing one having the following dimensions:

Bore, 2 3/4 inch; connecting rod, 5 3/8 inch between; stroke, 3 inch; valves, mechanical in head; intake, 1 1/8 inch with 3/16 inch lift; exhaust, 7/8 inch, with 1/4 inch lift; auxiliary exhaust slot opened by piston, 3/16 by 1 1/4 inch; flanges (cooling) number 15; width, 5-8 inch; thickness, 1-8-inch by 1-16 inch; between bases, 3/16 inch; compression, 7-8 inch; crankshaft, 1 inch diameter; offset, 3-8 inch; journals, two 3 inch and one 3-4-inch; crankpin, 2 inches long, 1 inch diameter; wrist bearing, 1-2 inch long; wrist pin, 5-8 inch diameter; cylinders, 3-32 inch thick with removable head, held down by four 3-8-inch rods.

I would like to know if the use of picric acid in gasoline will hurt the cylinder walls of a motor or give any other bad results.

Pullman, Wash.

GEORGE D. STACY.

Without going into detail, your design and dimensions appear to be perfectly practical, but, unless you have some special purpose in mind for which this motor is to be used, we should hardly recommend building such a small motor. Picric acid is used for etching specimens of steel used for tests, so that there is every reason to believe that it will have a similar effect on the walls of the cylinder. An excess of it would be likely to generate such a powerful explosion that the motor would be blown to pieces.

### EFFECT OF SPEED ON FUEL CONSUMPTION.

Editor THE AUTOMOBILE:

[1,115.]—What is the effect on gasoline consumption in driving a car over a distance, say one mile, at say 40 miles per hour; then 20 miles an hour; the gear ratios being the same in both cases? Would the higher rate of speed consume more gasoline?

Wilkes-Barre, Pa.

ARTHUR H. DENISON.

Speed has a decided effect on the gasoline consumption, and, generally speaking, the latter increases in proportion to the speed. Unfortunately there is not a great deal of data extant on this subject, but we have at hand the results of a series of experiments made by an English autoist. The car employed was a 20-horsepower machine with a touring body. At a speed of 10 miles per hour it ran 23.25 miles on a gallon of fuel; at 20 m. p. h. it covered 25.23 miles, while at 25 m. p. h. the mileage was the same as at the 10-mile speed. Increasing the latter to 35 miles an hour cut this down to 16.98 miles per gallon, from which it will be apparent that the most economical speed of the car in question was 20 miles an hour. Doubtless every car has a speed at which it covers the most ground on a minimum fuel consumption, which might be aptly termed its critical speed, only to be definitely determined by experiment.

### CAN DRY BATTERIES BE RENEWED?

Editor THE AUTOMOBILE:

[1,116.]—I believe it would please many of your readers if you would state, through "Letters Interesting and Instructive" whether there is any reliable and economical method of renewing old dry batteries. I have purchased advertised formulæ and have failed utterly in the attempt to renew batteries—not being able to secure an increase of even one ampere. To refill cells with the formula containing zinc chloride, ammonium chloride, zinc oxide, and sulphuric acid is more expensive than to purchase new cells—even at the usual price of the latter, which I think excessively high (25 to 35 cents each). I am now purchasing my dry cells in lots of 40 from the surgical supply house with whom I do business—these cells are as good as any in the market and cost me only about 20 cents each delivered. Another of the advertised methods of renewing old cells is to punch holes in the covering on top of the cells and pour in a saturated solution of saturated ammoniac (ammonium chloride). This has been proved to be—in my hands at least—a fake.

Glyndon, Minn.

L. M. LOWE, M.D.

Any solution that is advertised as being an effective rejuvenator of the dry cell is in exactly the same category—a fake. The question comes up very frequently and in view of the low price at which new dry cells can be purchased it is rather strange that it should be so. There is no way—at least at present—of renewing the dry cell by pouring solutions into it. What appears to be a completely exhausted cell may be compelled to give an increased output for a short time by the use of a strong alkaline solution poured into it through holes punched in the sealing of the top. This may be sal ammoniac and water, vinegar or even salt and water, the effect being increased by heating the solution. This is a makeshift that sometimes suffices to produce sufficient current to get a car home on an apparently dead battery. For a dry cell that is really exhausted there is only one remedy, a new one, and only one place for the old one—the ash barrel.

### HOW CAN LUBRICANTS BE TESTED AT HOME?

Editor THE AUTOMOBILE:

[1,117.]—We have been making a little experiment with cylinder oils and would like to know whether in your opinion there is any value attached. We took three different kinds of oil and put about a tablespoonful of each in a small tin cup and let them cook away on the top of a stove. Of course, the heat was not very great, but hot enough to cause the oil to steam. We took it for granted that the oil that cooked away first was the poorest. The writer considers that if the oil burns away inside of the cylinders it could also be burned away outside the cylinder. I have just heard from



a manufacturer and they think that the experiment is of no value whatever. Can you suggest some simple plan to test the oil without going to the chemist?  
Reading, Pa.  
S. L. McILVAIN.

So far as what the average automobilist wishes to learn about lubricating oils is concerned, simple tests may readily be made at home without the use of any apparatus. One of the most important tests is that for acidity, and the simple experiment suggested by Henry Hess in these columns not long ago may be easily made. Take a small rod or piece of bright steel and a piece of cotton waste wicking or something similar. Wet the latter in the oil and wrap it around the steel, setting this in the sun. If the oil in question be absolutely free from acid there will be no effect visible on the steel, no matter how long it is left, but even a comparatively small percentage will make its presence known at the end of a week or so, especially in warm weather.

To test the flash point of lubricating oil, take a tin cup or other vessel to hold the sample and place this on a Bunsen burner, i. e., a blue flame gas burner such as is used on gas stoves. Place a thermometer in the oil so that the bulb is suspended in the oil and does not come in contact with the metal or other containing vessel. As soon as the oil begins to vaporize, take a lighted taper and pass it back and forth through the vapor. When the latter reaches the temperature of the flash point of the oil the vapor will ignite in short blue flashes of flame, but it will not continue to burn nor will the oil take fire.

#### WHICH TIRE REPAIR IS SUPERIOR?

Editor THE AUTOMOBILE:

[1,118.]—Will you kindly advise automobile owners as to your knowledge in regard to tire repairs as I state the facts to you. For instance, take an automobile tire that has a blowout and has been repaired in first-class condition, the curing being done in a sectional vulcanizer with dry heat in first-class shape. Now, take another tire of the same repair, put it on a rim with air bag. Bandage it all around, put 35 or 40 pounds air pressure in your tire. Cure tire in a retreading kettle with open steam. Which repair do you think is superior and will give the best satisfaction?  
St. Paul, Minn.  
ANXIOUS SUBSCRIBER.

While we cannot set ourselves up as tire experts, we are strongly under the impression that what is known as the open cure process, in which the entire shoe is subjected to live steam in a sealed kettle, is considered much superior to the sectional vulcanizing process, but we are open to conviction and would like to hear from authorities whose statement is backed by personal experience and knowledge, instead of mere hearsay, as the matter is doubtless one of considerable interest to autoists at large.

#### IS CALCIUM CHLORIDE SAFE TO USE?

Editor THE AUTOMOBILE:

[1,119.]—Please let me have a definite answer in your "Letters Interesting and Instructive" in regard to calcium chloride as an anti-freezing solution. I notice in "The Automobile," where it spoke as though it was not safe to use, and the "Gas Power," of November, 1907, states that it is safe to use, as they have tried it four winters in an engine and could not see where it had the least sign of having ill effect on tank, engine, or any of the connections, any more than ordinary water would have. Your answer to the above will be very much appreciated by me and probably others.  
Portsmouth, O.  
HOWARD SUTTON.

We cannot recall ever having stated in these columns that calcium chloride was in any way a dangerous substance to use as the basis of an anti-freezing solution. However, it must be borne in mind that the mere fact that a certain thing can be used successfully in connection with a stationary engine will not make it equally applicable to use on the automobile. In the former case there is nothing but iron for the solution to come in contact with, as a galvanized iron water tank is generally employed, whereas on the automobile copper or brass is used in the radiator and as the solution is in contact with the iron of the cylinder jackets and the brass

of the radiator at the same time there is danger of electrolysis if acid be present. There is apt to be more or less hydrochloric acid in commercial calcium chloride and probably this is the basis for the statement that its use might be detrimental on a car, though, as already mentioned, we do not recall just where this occurred, or in what form. The defect is easily overcome by testing the prepared solution for acidity with a piece of blue litmus paper, which can be readily obtained at any druggists. If the test show acid to be present, it may be neutralized by the addition of a little alkali such as slaked lime. The presence of the acid will be indicated by the fact that the blue strip of paper turns red as far as it is immersed in the solution. Add lime, constantly stirring to insure uniformity, until there is no longer any acid reaction on testing with the paper. This will effectually remove any risk there might be in employing calcium chloride for this purpose.

#### CALCULATING A MOTOR'S COMPRESSION SPACE.

Editor THE AUTOMOBILE:

[1,120.]—Would you please send me a formula for figuring the compression of a gasoline engine? For instance, if the motor is 4 1-2 bore by 4 3-4 stroke, and we want 75 pounds compression. how would you go about it?  
Toledo, O.  
HARRY ALLEN.

The compression space of a motor is the entire area above the head of the piston when the latter is at the upper dead center. It includes the area of all ports and pockets leading into the cylinder and the amount of clearance thus depends entirely upon the design of the cylinder casting. When a charge is taken into the cylinder the volume of gas is equal to the volume swept out by the piston plus that of the compression space.

Then let  $V$  = the volume swept out by the piston, and  $C$  = the volume of the compression space. Their sum will represent the total volume of gas in the cylinder at the completion of the suction stroke, and since this is compressed into the space  $C$  the ratio of compression required to give

75 pounds initial compression will be  $\frac{75}{14.7} = 5.1$ , the denominator in this case representing the atmospheric pressure at sea level.

Then  $\frac{V+C}{C} = 5.1$  or  $V = 4.1C$ .  $V$ , which is the volume swept out by the piston at one stroke, is accordingly the equivalent of the area of the piston times the stroke. This gives the following formula:

$$D^2 \times .7854 \times L = , \text{ in which}$$

$D$  = the diameter of the cylinder, or bore in inches.

$L$  = the length of the stroke in inches.

$D^2 \times .7854$  = area of the cylinder.

Then, substituting the value of  $V$  in the foregoing equation, it will read  $= 4.1C$ , or

$$C = \frac{4.1}{D^2 \times .7854 \times L}$$

Substituting the dimensions of your motor in the foregoing equation will give you the number of cubic inches that must be allowed in the compression chamber to give an initial compression of 75 pounds to the square inch.

#### EXPLAINING THE VOLTAMMETER'S USE.

Editor THE AUTOMOBILE:

[1,121.]—Would like to ask whether a voltammeter runs down a battery as much as an ammeter?  
Warren, Mass.  
LOWELL ELLIS.

This depends upon which part of it is used, as a voltammeter is in reality two independent instruments combined in the same case, but capable of being used separately. If the ammeter of the combination be used on a dry cell or accumulator it will run it down just as much as if an ammeter

in an independent case were used. There is no difference, other than that of their combination in one case for convenience and portability, the instruments themselves not being altered.

### IN ANSWER TO THE CRITICS.

Editor THE AUTOMOBILE:

[1,122.]—In spite of the fact that Mr. A. S. Logan puts his claims for the utility of the "needle" in the nozzle of carbureters, in language most convincing, it does not hold that the nozzle needs such a disturbing element in its make-up. If the nozzle is thus provided, adjustment becomes a necessity, because it is extremely difficult to make the nozzle do its work under the several conditions incidental to the service. If a carbureter is otherwise improperly designed, the needle in the nozzle affords a means of relief that should be regarded as a temporary expedient; nothing more.

The nozzle cannot work in accord with the laws of the relation of the nozzle to the air, if the opening is obstructed, and that there is a law that can be taken advantage of is not to be refuted at this late day. There are hordes of the best performing cars, with carbureters in which the nozzle is free from the obstruction, and their performance is no dream. As the writer explained, once the carbureter is rightly adjusted, the needle valve ceases to be of any value at all.

As regards Mr. Logan's experience in a given case, the fact that the maker took the carbureter out and substituted another make, shows first that the carbureter was regarded as not suitable for the motor in question. This being so, to condemn the carbureter as a whole would be far more wise than to say it was the nozzle that was at the seat of the trouble.

Moreover, the fact that the second carbureter works, merely proves that the carbureter as a whole is more suitable for the purpose. Certainly the needle in the nozzle was not the redeeming feature unless the carbureter itself is of a defective design. The author purchased a motor a while back with which a carbureter was sent. In this case the needle feature was present, but in spite of it the carbureter is a flat failure, so flat, in fact, that even the maker of the motor refused to have anything to do with the carbureter. I guess he put his eye teeth in my legal tender, and regarded it as better property.

But, to show the lack of use of the needle in a carbureter that will work, it is only necessary to remove the needle and substitute a nozzle of the proper size and design.

Editor THE AUTOMOBILE:

[1,123.]—Lewis T. Rhoades is good enough to take some notice of my article on the subject of fuel (1,107), and if he will allow me the privilege of relating his proposition, I will agree with him. The substance of his statement is to the effect that if carbureters are made, not in view of the motor on which they are to go, but in the abstract, a needle valve is handy, even desirable, in that it affords a means of ready adaptation to the motor. I had not the slightest intention of interfering with any of the means by which make-shifts might serve a useful end. On the other hand, there is no use in going into the question of who does and who does not use needle valves in the nozzles of their carbureters, since it would be possible to name a considerable number of carbureters fitted both ways.

There is one fundamental reason why a needle valve should not be used, a reason that I will now advance, since the question is so strongly raised, i. e., no device should have more than the exact number of parts requisite to render it serviceable.

The needle in the nozzle is not essential to the working of the carbureter, hence, on the above ground, the needle might well be dispensed with.

New York City.

THOS. J. FAY.

### THE RETORT COURTEOUS TO MR. POOLE.

Editor THE AUTOMOBILE:

[1,124.]—I am glad to be able to reply to the strictures of Cecil P. Poole (Editor "Power"), in which he takes me sharply to task about my article on carbureters, etc. Mr. Poole says: "Mr. Fay ought to know by this time that the richness of the mixture increases with increasing speed, unless special provision, such as the modern auxiliary air valve, is made to prevent it. . . ." Mr. Poole may not have observed that the article in question illustrated the very modern auxiliary air valve he says is necessary. I doubt if it is modern. I respectfully take issue with Mr. Poole, in re. the question of "better scavenging at the higher speeds!" Every indication is to the contrary! Every builder of motors has considerable trouble with them at the higher speeds, because "missing" is difficult to avoid.

The question of the timing of the spark is not one that I have taken up in my article further than to point out that the discussion assumed that such matters would be given their due measure of care. Mr. Poole may have at his disposal a very recently abridged

dictionary, telling him that it is "constriction" instead of "depression" that is required in the intake; my old-fashioned dictionary tells me that as a result of "constriction" there is "depression." It is the depression that is sought for, and to gain which the area of the intake is constricted. This matter may be further elucidated, viz.: Depression, dejected; low state; a falling or sinking; a hollow; Webster! And what will cause this state, let us see. Constrict: to draw together; to bind; to cramp. Webster.

"Combust!" is not to burn, as Mr. Poole puts it! The dictionary says: a combustible is that which will take fire. Combustion, according to the same source of information, is the phenomenon observed when the combustible is ignited, hence, a burning. Webster. I said in my article, "The carbureter, then, is intended to produce a combustible of acceptable characteristics . . ." I do not claim elegance of diction, as the shining property of this statement; nor have I at any time, in any of my writings, claimed for my composition that elegance I so readily found in the writings of the author of "Eugene Aram." It was but a few days ago I read in some one of the many papers, that even another error was found in one of the works of "Dickens." Did they condemn the works? Far from it! the meat in the cocoon is the same!

Would I be justified in condemning Mr. Poole because his recently abridged dictionary does not agree with the older copy in my possession? Does the fact that his dictionary is new make it right? The carbureter is a very ticklish device to discuss in the press! There are so very many makes to be had at every hand it is not possible to avoid treading on the toes of some one or more whose interests may be affected. Whilst it may be possible to tickle their carbureters, to perform that operation on them would be a "hair splitting" proposition, beyond the pale of human endeavor.

New York City.

THOS. J. FAY.

### COMES TO THE SUPPORT OF MR. FAY.

Editor THE AUTOMOBILE:

[1,125.]—In your "Letters Interesting and Instructive," I note that No. 1,106, from Cecil P. Poole, does but scant justice to Mr. Fay's article on the subject of "The Fuel System of Automobiles." This in itself would not be a matter of great moment, because the carbureter is a device that has long been in grave dispute. I do not know whether I would be willing to subscribe to all that Mr. Fay said, nor am I prepared to say to the contrary.

What strikes me, however, is this: Mr. Poole, instead of setting down facts, resorts to imputations, such as would lead one to believe that his motives may not be pure. The little information Mr. Poole does condescend to hand out is a splendid display of lack of knowledge of the functions of a carbureter; moreover, if Mr. Poole's imputations are no better than the information he so kindly rattles off the reel, an "exhaustive enumeration" from him would be greatly to the advantage of Mr. Fay.

Mr. Poole's assertion: "The scavenging effect is better at high than at low speeds," would be a crime were it possible to discover anyone who would act on the suggestion, assuming damage could result! The compression is higher at the low speed, the amount of mixture is greater and the terminal pressure is higher.

With more time for the products of combustion to escape, a greater terminal pressure available, better conditions in every way, it is simply nonsense to say that the inertia of the spent mixture overbalances all other considerations, nor can it be said the inertia factor is maximum at the higher speeds.

New York City.

AL. C. BERGMANN.

### CONCERNING THE USE OF CORK INSERTS.

Editor THE AUTOMOBILE:

[1,126.]—In letter 1,060, in the January 2 issue, the writer asks your opinion as to the advisability of making "an expensive remedy for clutch trouble" proposed by his machinist, a remedy which you advise against and suggest that he do away with the leather facing and substitute cork inserts, thus making a metal-to-metal clutch with cork inserts.

As we are owners of the patents controlling the use of cork inserts in clutches and brakes and have had much experience in their use, we can assure the writer of the above-mentioned letter that the use of these inserts will eliminate his difficulty with less expense and give more permanent satisfaction than any other method of repair we know of; but we would suggest that for his purpose it will not be necessary to do away with the leather facing, as the corks can be inserted in the leather, making a composite cork and leather surface having high coefficient of friction, practically no tendency to slip or burn, and at the same time one which gives easy engagement. This type of clutch is used in the Pierce-Arrow, the Pope-Hartford, the Reliance, the York, the Garford, the Studebaker, the Oldsmobile, and many other well-known makes of cars.

Another letter, No. 1,062, in the same issue, makes a similar inquiry, and asks, "How would three cork inserts do?"

The cork inserts will give the results stated by you, but the area

of cork to leather or cork to metal is dependent on the horsepower to be transmitted, size, angle, area of face, etc., of the cone, and your suggestion that the writer correspond with the maker of the car or the manufacturer of cork inserts before proceeding is wisely taken.

While the royalty of \$2.50 charged by us does not compensate us for the time devoted to replying to the hundreds of letters received asking how the clutches are equipped with these inserts, where they can be bought, number of inserts required, etc., we have made it a point to supply the information on request and to arrange so that each individual owner who desires to have his car so equipped could accomplish this at the least possible expense, and we shall, of course, be glad to do likewise in either of the cases mentioned.

NATIONAL BRAKE & CLUTCH COMPANY,  
Boston, Mass. W. W. Whitcomb, President.

### NOT A QUESTION OF PATENTS.

Editor THE AUTOMOBILE:

[1,127].—In announcing to the press the result of our test suit against the Manhattan Lamp Works for imitating the design of the Rushmore Flare Front lamp, we thought we made it clear that the case was purely in equity and against unfair competition as such. We find, however, that most of the papers are reporting the decision as though it upheld a patent on the design.

There is not, and never was, any question of a patent involved. Experience has shown design patents to be worthless as protection against copying, since the slightest departure from the design is sufficient to protect the infringer. Unfair competition, however—the copying for imitation of a shape or label or trade name, for the purpose of misleading purchasers into thinking that the imitation article is identical with or as good as the original—is quite another matter.

When a manufacturer has built up a reputation for his goods, no one has the right—patent or no patent—to endeavor to steal that reputation by palming off imitation goods as the genuine. If the substitute is as good as the original, the manufacturer of the original suffers only loss of business and the just reward of his effort. But when the substitute is inferior to the original, and is offered by some copyist without initiative and skill of his own, the injury is three-fold. The original manufacturer suffers loss of both business and reputation, since the poor performance of the substitutes tend to discredit the original, and the public buying in good faith is likewise defrauded.

The law on the subject of unfair competition is very little understood by the public in general, as the frequent copying of meritorious articles plainly shows. We regard our fight in this matter as being in support of a higher plane of business ethics, and know that we have the sympathy of the best people in the automobile trade.

RUSHMORE DYNAMO WORKS,

Plainfield, N. J.

S. W. Rushmore.

### ECONOMICAL FIGURES FOR 6,000 MILES.

Editor THE AUTOMOBILE:

[1,128].—Here is an expense account of a Ford Model N which may interest your readers. It has been run 6,000 miles, in the country and city, without being in for repairs but three times:

Car, K. W. Magneto, Pittsfield coil, Bemus timer, lamps, top, long fenders, chains, speedometer, etc. ....	\$850.00
Tires .....	75.00
Gasoline .....	45.00
Overhauling .....	50.00
(To clean out carbon three times.)	
Oil, plugs, batteries .....	25.00
Washing, storage on trips, etc.....	75.00
<b>Total .....</b>	<b>\$1,120.00</b>

Answering a question published some time ago, the K. W. magneto has been very satisfactory with the Pittsfield coil, but would not work with the cheap coil on the machine at first.

You will note that this figures about 4 1-2 cents per mile, which I consider pretty good. I have never managed to operate any other machine (I have had six before) for less than ten to twenty cents. Gasoline runs as high as 27 miles per gallon, but I have figured 20 miles as an average; oil about 500 miles per gallon.

I have been much interested in the expense accounts which you have published, and a great deal seems to depend on the driver.

Cleveland, O.

G. S. C.

### SUCCESSFUL USE OF KEROSENE FOR COOLING.

Editor THE AUTOMOBILE:

[1,129].—In the January 2 issue of "The Automobile" W. B. Hill writes regarding kerosene as a cooling agent. I use kerosene and have used it all winter, or rather since it has become quite cold,

and have experienced no bad results as yet. My motor never gets hot, although I have nearly half of my radiator covered to keep the oil from getting too cold. In using just pure water, I cover the radiator entirely and leave it so all the time and the water never boils. With the radiator uncovered in cold weather, my pipes will freeze on the road, having done this on two occasions. With a positive pump as the Reo car has, the writer would not hesitate to use kerosene, unless used under very severe conditions where the motor was worked to the limit most of the time. Lubricating oils soften rubber connections very rapidly if warm. I know of a gas engine company that uses nothing but oil as a cooling agent, with a gear pump, and experiences no trouble whatever. This is on traction engines of large dimensions, which are worked to the limit most of the time, being used on a gang breaking plow on the Western plains. As far as danger goes, the water system can and should be as tight as the gas tank. All that is needed is a very small vent, and this is not absolutely necessary in the cooling system providing the water does not get above boiling temperatures. Would be pleased to hear from some one who has data on flashing point of oils in pipes under slight pressure heat to be applied externally.

Frederika, Ia.

CECIL E. CARR.

### PUTTING A VESTA ACCUMULATOR AWAY.

Editor THE AUTOMOBILE:

[1,130].—The writer noticed, in your issue of Jan. 2, 1908, your article on page 17, in answer to an inquiry of Dr. E. C. Lee, of Duluth, Minn., asking for information regarding the care of the Vesta battery during the winter.

You, evidently, are not very well posted on the Vesta sparking battery, and as a consequence you gave instructions for the general care of a power battery, such as is used on the electric automobile and in power plants.

All that is necessary in taking care of the Vesta battery during the winter, when not in use, is to set it away fully charged and to keep it in a room of moderate temperature. It is advisable, if it is set away for a longer period than three months, to freshen it up at the end of three months, by giving it one-half a charge and then when ready for use in the springtime have it charged again. No injury will result to the battery if cared for in this manner.

We trust we have explained ourselves clearly in the matter, and remain,  
VESTA ACCUMULATOR COMPANY,  
Chicago, Ill. Ward Perry, Secretary.

### AN APPRECIATION FROM A WESTERN AUTHOR.

Editor THE AUTOMOBILE:

[1,131].—This is not for your "Letters Interesting and Instructive," asking how to make an old 15-horsepower do the work of a modern 40-horsepower by cleaning the spark plugs or changing the ratio, which is such a pet scheme for creating power with some of your correspondents, but the author of the booklet from the Lima (Ohio) Automobile Club, on the subject of "Highway and Road Etiquette," wishes to thank you for the overgrown compliment which you have paid me by republishing my entire work in your valuable and widely circulated magazine, of which I have long been a faithful reader. The original object in writing the book was educational in a local way only to stimulate a desire for better roads among our farmers, and to try to teach them how to make a quick side step on the approach of an automobile without compelling us to hold out the clutch while they decided whether they would let us pass to the right or to the left—or not at all; but if it can serve a similar purpose in a broader sphere, it is a double recompense for services rendered.

Lima, O.

CHAUNCEY F. LUFKIN.

### SATISFACTORY SERVICE FROM DRY CELLS.

Editor THE AUTOMOBILE:

[1,132].—I noted with interest the remarks that your correspondent makes who signs himself H. W. in letter No. 1,090, as I have myself received perfect service from dry batteries since I introduced a well made coil in my car, which does not draw over 1-4 ampere if properly adjusted. H. W. states he ran 1,600 miles on a set of batteries with the coil drawing 3-4 of an ampere, and I would advise him to make another test with his coil readjusted, drawing only 1-4 ampere. I have yet to find an engine of any compression which will not perfectly work on this consumption, and some manufacturers even claim that perfect results have been obtained as low as 1-20 of an ampere.

Through my garage experience I can say that almost universally those complaining of unsatisfactory results from dry cells have not the slightest idea of the coil consumption or the condition of the wiring, and, therefore, batteries are blamed where the fault lies elsewhere.

New York City.

C. R. B.



**I**N order to meet both the price and quality demand of a very large class of purchasers, it is essential that production be both systematic and on a large scale so as to insure a moderate initial cost. This is something the makers of the Mitchell, the Mitchell Motor Car Company, Racine, Wis., have done, and the nature of the changes made on the cars of the Mitchell line for 1908 are indicative of consistent adherence to a well-outlined policy of manufacturing. For instance, an increase in the comfortable riding qualities of the cars has been brought about by a slight lengthening of the wheelbases, the touring car now measuring 112 inches on the ground as against 108 last year, while the 1908 runabout has been lengthened two inches, giving it a wheelbase of 92 inches. The gentleman's roadster, or Model G, is mounted on the same chassis as the runabout. The same running gear and tire equipment as that which has proved so satisfactory on these models during the past year or two remains unchanged, and it may be observed here in passing that this is one of the chief faults of many an otherwise clever designer—the abandonment of well-tryed-out devices and dimensions for something new and unknown, frequently for no other reason than that it is new.

In the line of improvements, that most important essential of any car—the braking equipment, has come in for due attention. In the touring car model of the year previous, the brake drums measured 10 1-2 inches and have been increased by four inches in the 1908 models, while the runabout brake drums have been increased from 9 to 10 1-2 inches. The braking system employed is that of the combined external contracting and internal expanding brakes acting on the same drums attached directly to the driving wheels. All brake shoes carry a friction facing of fiber, experience having shown this material to be very satisfactory in service. The suspension has not been overlooked, and on the 1908 models all springs are now two inches wide and are banded, no center holes being drilled. Universal joints have been protected by a combined steel and leather casing which is both oil and dust-proof. The same type of change-speed gear has been retained, but a much better grade of material employed throughout, from

which it will be evident that it is the designer's constant aim to adhere to a consistent policy of betterment by building on the well-tryed-out foundation already in hand, than to strike out into new and unknown fields, as is so often done, frequently for no other reason than to gain talking points. The rear axles have not been changed in any way, the design and material having proved perfectly satisfactory in the preceding models. Front axles, while of the same materials, have been designed to allow the chassis of each model to hang two inches lower, though the road clearance in every case remains unaltered. This change is responsible for the improvement in the suspension made in the present year's models.

The refining process has been carried out in the motor in the same painstaking manner and with the same close attention to detail that characterizes the other improvements of the car. The camshaft diameter has been increased from 3-4 inch to 7-8, the cam face being made one inch wide, while the applied middle bearing of the camshaft in the 1907 model is now made integral with the motor base. The cap is secured with a screw bearing on a stiff spring, to prevent the application of injurious pressure to it. Two minor changes have been made in the valve operation, which is of the direct type on the intake and of the overhead type on the exhaust, the latter being placed in a cage in the center of the cylinder head and worked by a vertical push-rod, screw-adjusted for length in the top fork and having its lower end dropped into a cup in the upper face of the cam roller carrying lifter. The lifter has been made slightly longer and its diameter increased, permitting the push rod cup to be formed directly in the end of the lifter. The intake valve stem has also been given a screw length adjustment. The timing idler used

between the crankshaft and camshaft has been eliminated, the former pinions having been made large enough to engage directly. The hinged rod cap on the crank wrists has been replaced by a full marine type retained by two studs with lock nuts. The bore of the 20-horsepower motor has been increased from 3 3-4 to 4 inches.

Where the transmission is concerned, the cone clutch has been fitted with six

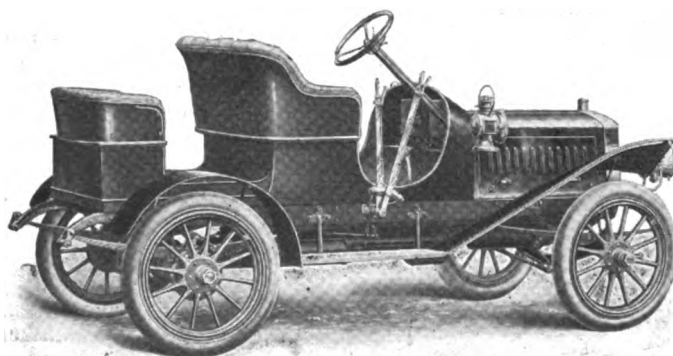

THE MITCHELL GENTLEMAN'S ROADSTER FOR 1908.



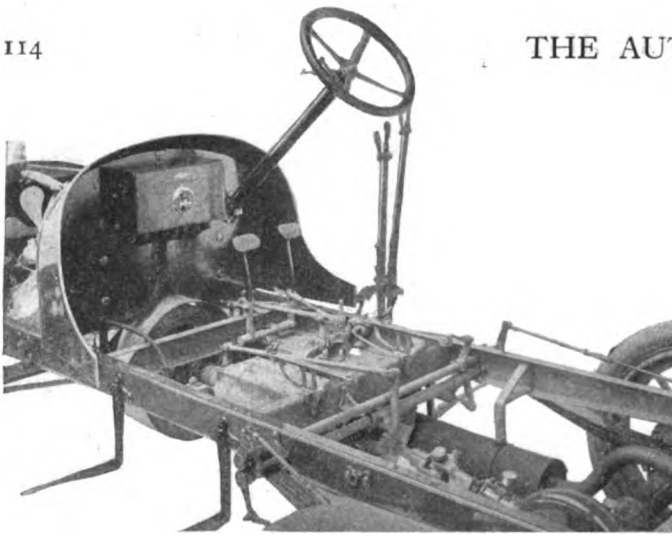

VIEW OF DASH AND CENTRAL PORTION OF CHASSIS.

springs to insure gradual engagement. The pinions of the gear-set are now made of special oil-tempered steel of 6-8 pitch, it having become standard practice to make gear teeth for this purpose shorter than standard lengths, thus gaining in strength by saving outside diameter as well as in machine work. The shafts are carried in babbitt bearings supported in an aluminum housing with cast-iron cover, the latter adding rigidity to the lower member.

The front axle is an I-beam section of drop-forged steel without welds and using the Lemoine type of stub axle support. Two-point adjustable ball bearings are used, the balls measuring 1-2 and 3-4 inches, respectively. Hyatt roller bearings are used on the rear axle except on the inside bearing of the bevel pinion shaft, which is an annular ball bearing, while all thrusts are taken on ball disks. The differential gear is of the spur type, employing eight pinions. The control is of the standard type throughout and reveals but few, if any, material changes over that of the preceding models. Instead of equalizing the brakes in the usual manner, the pressure applied to each brake shoe is regulated independently by a screw adjustment readily accessible when the footboards are lifted. The steering gear is of the worm and segment type, the spark and throttle levers being placed in front of the column. As the result of the great demand for Mitchell cars last year, the manufacturers found it necessary to increase their facilities substantially, with the aid of which they plan to turn out 2,200 pleasure cars and 120 motor trucks during the coming season.

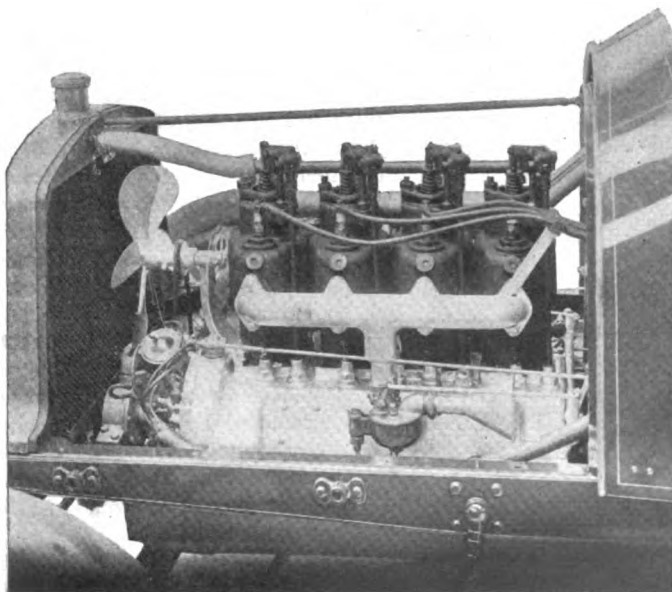

CARBURETOR SIDE OF MOTOR SHOWING VALVE MECHANISM.

### NEW TYPE OF FRICTION TRANSMISSION.

This is a device intended to act as a means of changing the ratio of the speed of the motor of an automobile and its driving wheels, and to transmit the power of the former. It is the invention of J. U. Baker of Stoutsville, O., and differs considerably from the usual type of friction transmission now employed for this purpose. It consists of an angle steel frame, carrying a friction disk at each side. These disks each have two bevel faces and are mounted in extension bearings. The bevel faces on the disks are spaced five inches apart at their outer edges, admitting the insertion between them of the speed cones, which are mounted on an extension of the propeller shaft, the latter being supported by three bearings, two of them on the ends of the frame, and a center bearing mounted on a pillar supported by a longitudinal bracket beneath the center of the frame.

The primary section of the driving shaft extends from the motor to a point just inside the outer bevel surfaces on the disks. At this point the drive shaft bears a cone keyed to it,

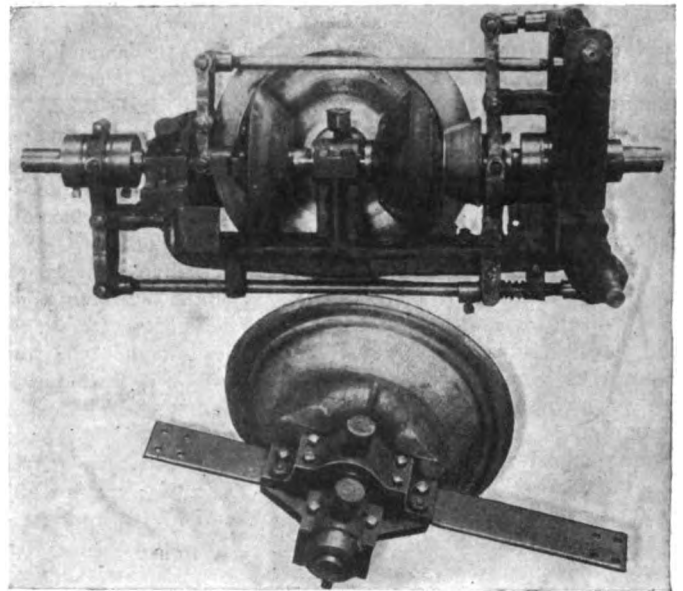

THE BAKER FRICTION TRANSMISSION SHOWING THE SPEED CONES.

this cone entering and engaging the cup cone keyed on the end of the driving shaft just in front of it, as will be seen upon reference to the photographic view of the device in which one of the friction disks has been removed in order to illustrate its details and manner of operation. This cup cone is in reality two cones, containing a smaller inverted cone at the bottom of the hollow of the first. The tapered end of this inverted cone extends outward and engages in the recess of the first cone mentioned, thus giving a double V-shaped locking engagement which gives the direct drive on high speed. On the propeller shaft, opposite the outer bevel surfaces of the disks, is mounted the primary cone, which is movable on a feather and is brought into engagement with the two outer surfaces of the disks.

By a double acting lever arrangement, the larger and inner cone keyed to the end shaft comes into engagement with the inner bevel surface of the disks at the same time that the primary cone engages, thus producing a speed reduction between the motor and driving wheels in the ratio of 3.25 to 1. For reversing, a pedal-operated lever brings the primary cone into engagement in conjunction with the larger cone mounted on the rear portion of the driving shaft, this cone also sliding on a feather. The shaft-locking or coupling device is operated by sliding the rear section of the driving shaft forward by means of the speed lever attached to the yoke mounted on this part of the shaft.

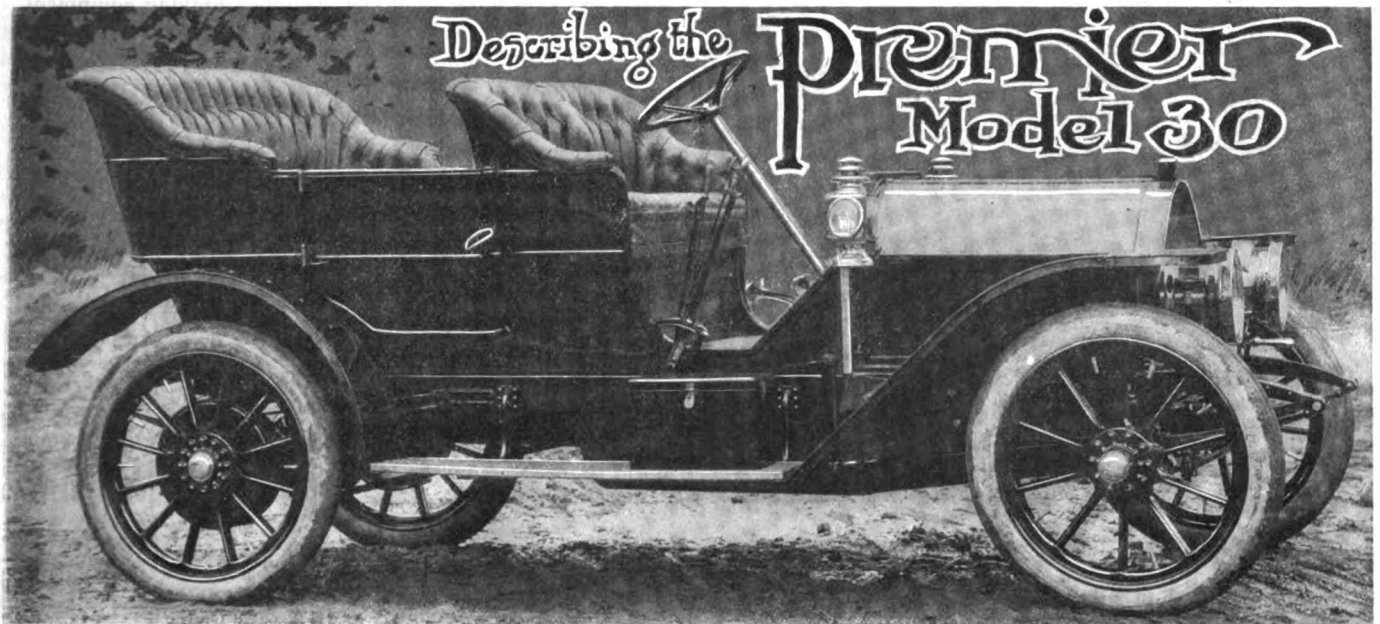

ONE of the chief improvements to be found on the Premier cars for 1908 is the adoption of low-tension ignition on Models 30 and 45. A Bosch magneto is used as a source of current supply and the arrangement of the system is of particular interest. Long pitch spiral gears are located on the intake camshaft, so arranged as to drive the vertical shafts on which they are placed, the cams operating to make and break hammers. The vertical shafts are in two parts, the lower end carrying the spiral gear being journaled in the crankcase, while the other end carries the cams and is journaled in a Hess-Bright ball bearing, the latter being located on the cylinders directly under the cams. A three-jaw clutch coupling joins the two parts of the shaft which are marked so as to facilitate their reassembly without disturbing the ignition timing. The pitting of the electrodes common in such systems has been obviated by making both contacts of liberal size and employing iridium-platinum, which is fastened by brazing with pure copper.

One of the distinctive features of this ignition system is the method of cushioning the contact, a patent having been applied for on the device employed. By this means, the wear of the igniter points, bushings, cam rollers, cams and other moving parts is automatically compensated for, besides which it provides a hammer giving a large spark at lower motor speeds, which greatly facilitates starting. The spark occurs right in the path of the incoming gas, as the points are located directly over the inner edge of the inlet valve. To electrically connect the different igniters, a 1-4-inch brass rod, protected by a fiber tube, is employed, together with small knife switches. The auxiliary ignition system is of the high-tension type, employing an improved type of secondary distributor and single vibrator coil especially designed to stand constant hard service. Both systems are advanced at the same time and in

the same ratio by a single lever located on the steering wheel, and each can be independently adjusted.

Though this is one of the chief features of distinction between these two models of the Premier and their predecessors, they also incorporate numerous others, such as the twin-cylinder castings with independent water jackets, thus gaining the advantages of uniform expansion as with independent cylinders without the extra water connections necessary on the latter. The valves are of nickel-steel and work in easily renewable bushings. Instead of the double or triple "Y" type of manifold ordinarily employed, the cylinders are provided with a longitudinal intake port beneath the valves, the mixture being introduced through flanged "T" fittings, thus making the connections very short and providing equal suction for each cylinder. This gives the effect of heating the intake by water jacketing and prevents condensation at low speeds. The "T" connections between the pairs of cylinders are equipped with slip-joint stuffing-boxes. Aluminum cover plates are employed on the large openings in the jackets, thus permitting access to the entire interior while their fastening of small machine screws prevents damage from freezing, as they would readily give way long before the pressure became sufficiently great to endanger the cylinder casting itself.

Another feature of note is the use of a pressed steel oil pan divided into two compartments in the four-cylinder and three in the six-cylinder car, to form the bottom of the crankcase, a mechanical force-feed lubricator being located under the bonnet in close proximity to the exhaust pipe, and feeding to the cylinders just below the second piston ring when the latter is down, the other bearings being taken care of by the splash lubrication of the independent oil compartments. A feature

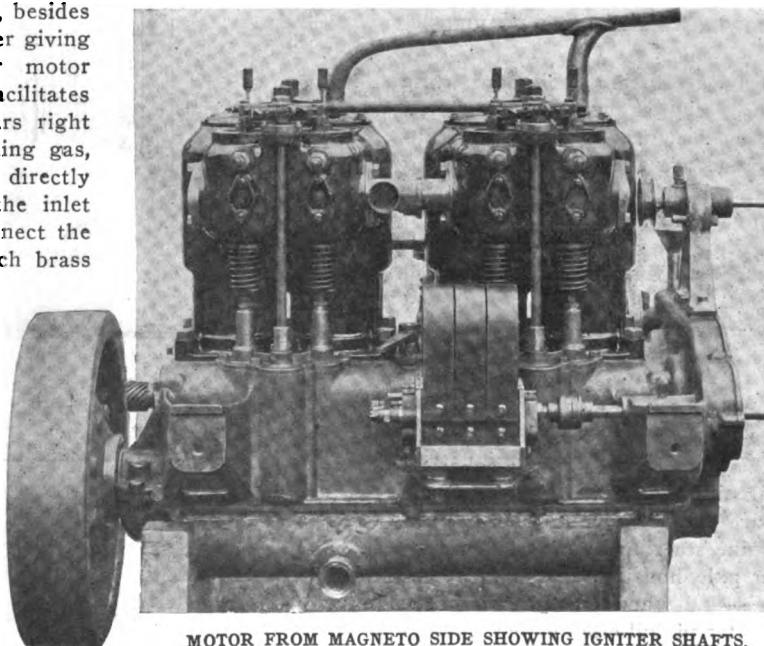

MOTOR FROM MAGNETO SIDE SHOWING IGNITER SHAFTS.

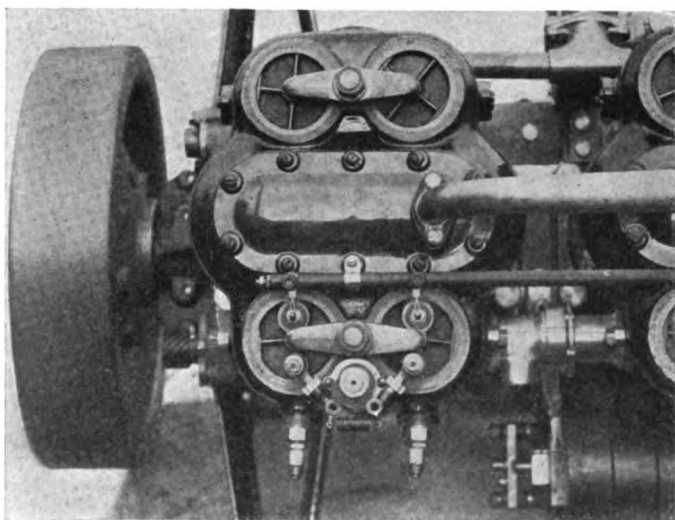

TOP VIEW OF TWO-CYLINDER UNIT WITH IGNITER DETAILS.

that will be found of great convenience by the user of the Premier is the provision of a bull's-eye showing the oil level in the splash compartments. With regard to the remainder of the motor, the pistons are cast from selected gray iron and chilled inside. After being roughed out all over they are annealed and set aside for some time, each piston then being ground to exact size with a slight taper at the upper end. Four rings are employed. The connecting rods are I-beam

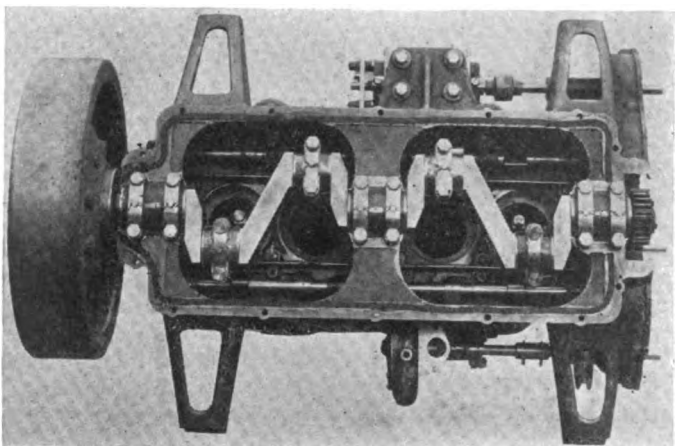

BOTTOM VIEW OF MOTOR, SHOWING LIBERAL SIZED BEARINGS.

drop-forgings, the main bearings consisting of Parsons white brass bushings held in place by cap screws and lock plates. Drop-forging, rough turning, special heat-treatment and finishing on the grinding machine are the various processes through which the crankshaft is put. It is of large diameter and of special steel. The upper half of the crankcase is of close-grained cast iron, and while slightly heavier than aluminum, it provides a rigid support for the cylinders as well as the crankshaft and camshaft.

A Weston multiple disk type of clutch forms the first step in the transmission, and is employed with a direct pressure spring. The connection between the clutch and gear-set is through a hardened floating shaft squared within the forward end of the clutch spider and having a three-jaw clutch-coupling at its other end, the jaws being slightly spherical and thus acting as a universal. Final drive is by shaft. Some of the other specifications are pressed steel frame, I-beam drop-forged front axle, Lemoine steering knuckles of vanadium steel, crucible steel rear axle housing, Hess-Bright annular ball bearings in gear-set and wheels, Schwarz wheels, long semi-elliptic springs front and full-elliptic rear, honey-comb radiator of autogenously welded tapered copper tubes,

and extremely liberal and well-designed braking equipment.

In the case of practically every one of these features the detailed specifications would be of considerable interest did space permit of enlarging upon them. For instance, the radiator is fastened to the forward end of the frame by reinforced bronze brackets, the whole being mounted on a rubber cushion, while the top of the radiator is not fastened in any way, thus preventing distortion. Circulation is by means of centrifugal pump gear-driven by a fiber pinion inclosed in the crankcase. The water connections are made of autogenously welded copper tubes of smooth interior and have been designed of such generous size that in case of stoppage of the pump the water would circulate freely by the thermosyphon action. A feature of the radiator itself is the provision of a large expansion tank, thus preventing waste when the motor is raced suddenly. A drain cock is inserted in the pump suction pipe, this being the lowest point, so that it permits of draining the entire system.

The brakes are likewise worthy of special mention for



THE SUBSTANTIAL REAR AXLE UNIT WITH ITS STEEL HOUSING.

more reasons than one. Two systems are employed, both being applied to drums measuring 14 7/8 inches diameter by 3-inch face, made integral with the hubs. The foot brake is pedal operated and consists of an internal expanding bronze ring, each ring carrying 44 cork inserts 1 1/8 inches in diameter compressed into 3/4-inch holes. The expansion links employed caused the braking ring to be carried centrally when not in use, thus eliminating any drag. The emergency brake is lever-operated as usual, and consists of a contracting band lined with camel's hair belting. Both brakes are equalized by means of pressed steel brake beams sliding in reinforced slots in the sides of the frame members, thus giving an equal amount of resistance at each rear wheel and minimizing the tendency to skid when braking. Provision is made for very easy external adjustment for wear on both sets of brakes, this being a feature long needed on the average American car.

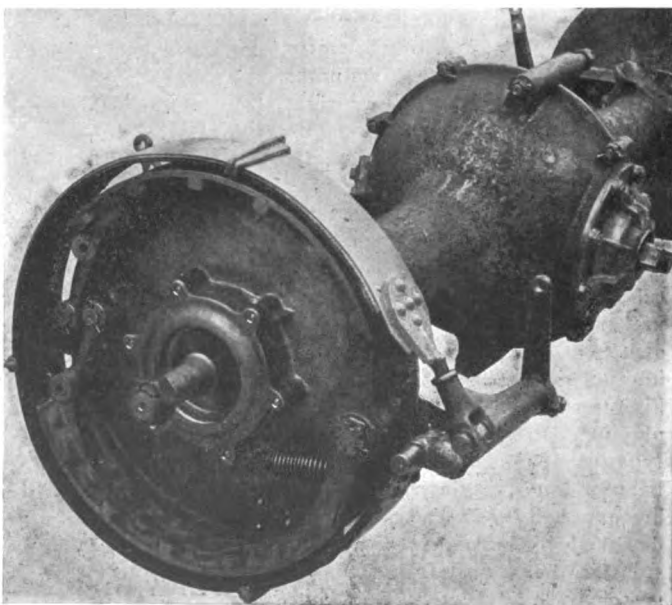

BRAKE DRUM ASSEMBLY SHOWING LARGE NUMBER OF CORK INSERTS.



## THE SELDEN A BRAND NEW COMER FOR 1908

**L**AST week there arrived in New York one of the first of the new Selden cars, which are now being built at Rochester, N. Y., by the Selden Motor Vehicle Company. The car is the work of E. T. Birdsall from beginning to end, and to those who are familiar with this de-

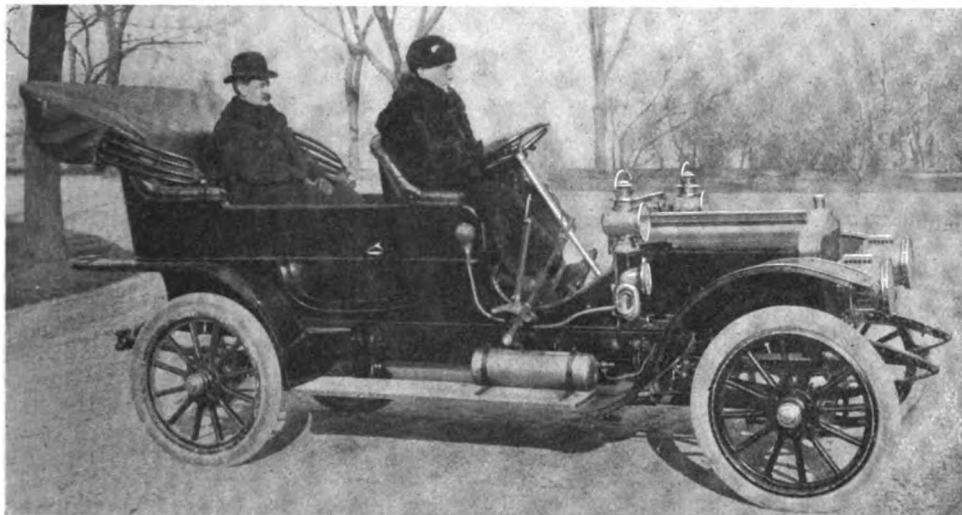

DESIGNER E. T. BIRDSALL IN THE NEW 30-HORSEPOWER SELDEN.

signer's career in the automobile field and his achievements before entering it, this in itself is a sufficient guaranty of its worth. But the car speaks for itself far better than the reputation of any builder or designer alone possibly could, and the first question that those who have had an oppor-

tunity of looking the new production over, have given vent to, is "How do you do it?" and then as an after thought, "How long are you going to do it that price?"

But, as a keen observer of automobile conditions in this country, Mr. Birdsall has carefully studied every detail of the matter. "There is no intention on our part of selling the first series of cars at this price, and then, as soon as people know what they can do, of jumping it," said Mr. Birdsall in an interview.

Built to sell at \$2,000 in complete running order, the new 28-30-horsepower Selden represents the materialization of a well-known designer's ideas of what the medium-priced car should be, and there is no question whatever in the minds of any of those who have seen the car and ridden in it that he has struck the nail fairly on the head. The engine is of the four-cylinder vertical type, with cylinders cast in pairs, valves all on the right-hand side operated from a single camshaft by the direct thrust method.

For ignition one of the new Splitdorf four-unit, non-vibrating coils with a master vibrator is employed in connection with a set of accumulators, a Schebler taking care of the essential of carburetion. The transmission consists of a leather-faced cone clutch, a three-speed selective gear set and shaft drive.

## CHICAGO NOW THE HOME OF A NEW STEAMER

**I**T has long been reported that the American automobile world was soon to see a new steam car from the hands of Webb Jay, the former racing driver, whose experience with this type extends over a number of years, but no hint of what the newcomer would look like has been allowed to leak out, so that the accompanying photograph of this entrant into the steam ranks, which claims Chicago as its home, reveals its lines for the first time.

It is known as the Webb Jay Steamer and is considerable of a departure where this type of car is concerned, as the entire power plant has been installed beneath the bonnet forward without making the latter unduly long or bulky. As a matter of fact, it bears more of a resemblance to a six-cylinder gasoline car than anything else, and the employment of a double side chain type of drive, which also represents a radical departure in this field, further carries out this idea. Moreover, the control, centered on the steering wheel in much the usual manner, is also patterned more or less closely after standard practice in the gaso-

line field, so that the car is apt to deceive even those observers who are accustomed to give more than a casual glance to such matters when they see a new car for the first time. A graceful and roomy body of the straight-line type is fitted, and the whole car is well-proportioned and attractive, as will be evident upon reference to the accompanying photograph of one of the first of the new Chicago productions.

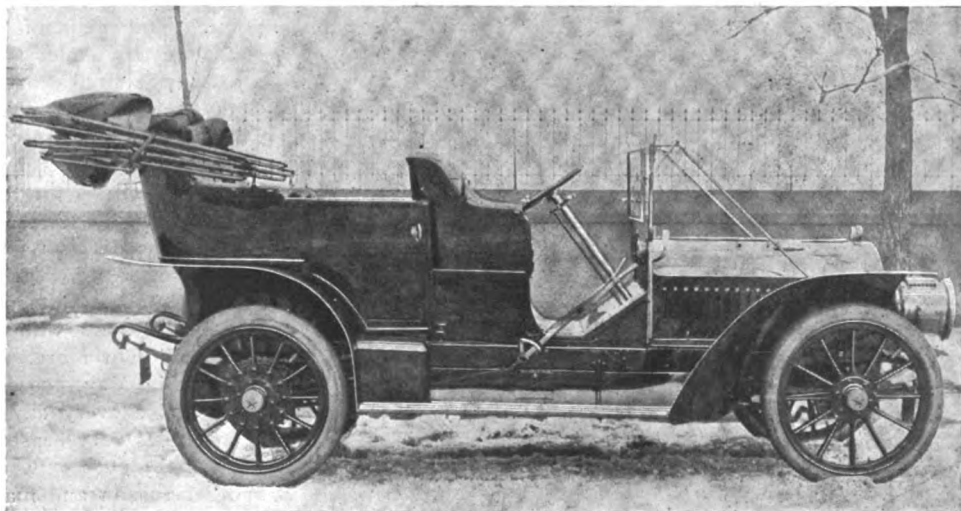

STRIKINGLY ATTRACTIVE LINES OF THE NEW WEBB JAY STEAMER.



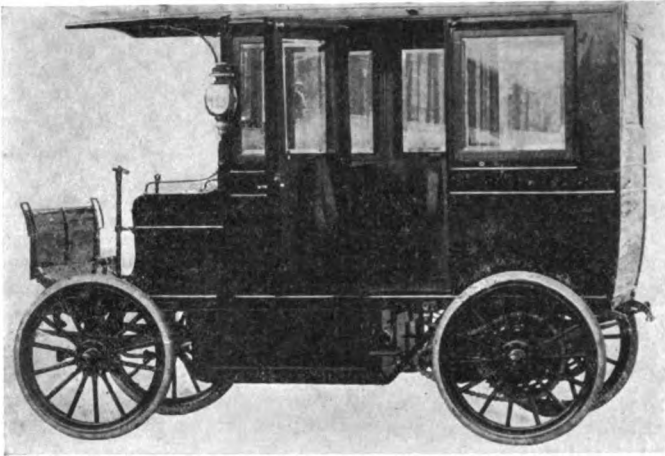

#### STUDEBAKER BUILDS ELECTRIC BANK WAGON.

The National Bank of Commerce of St. Louis, Mo., has recently put into commission an electric bank wagon which was built for it by the Studebaker Automobile Company, of South Bend, Ind. The body was built upon the bank's specifications. A door opens on each side in the center. Just in the rear of the driver's seat and extending under it, and wholly inside the body, is located a strong box made of wood and lined with heavy sheet steel.

#### AUTO PATROL WAGONS POPULAR.

INDIANAPOLIS, IND., Jan. 20.—One department of activity in which the commercial vehicle is daily gaining ground is that of municipal service and particularly as an aid to the police. A large number of American cities have already adopted automobile patrol wagons, the latest of these being Indianapolis. Last summer the Department of Public Safety in the latter city made a very thorough test of a Rapid commercial car, and as a result have decided to purchase three of them for regular police service. The tests extended over two days, from noon August 17 to August 19, in which time 51 runs were made. The average trip was 29.3 blocks and the average time consumed in making the trip was 11.5 minutes. This included getting under way by starting the dead engine, which required eight seconds on the average, loading the prisoners, telephoning to headquarters, and the like. Another feature of the tests was the economy shown by the car, as a total of 185 miles was covered on 12 gallons of gasoline, an average of 15 1-2 miles to the gallon, making the cost for fuel 1 4-37 cents per mile—a most excellent record for a commercial car of this size.



RAPID MOTOR VEHICLE COMPANY'S LATEST PATROL WAGON.

#### STODDARD-DAYTON ADDS SPECIAL LANDAULET.

An interesting type of automobile designed for service in towns has been produced by the Dayton Motor Car Company, Dayton, Ohio. As will be seen from the illustration, the car is fitted with a special type of landaulet body for two persons, and has many features which recommend it for use by physicians, ladies shopping or visiting, or the numerous services of a town carriage.

Model 8N, as it is known in the Stoddard-Dayton catalogue, has as its motive power a four-cylinder engine with cylinders cast in pairs and measuring 3 7-8 by 3 3-4 bore and stroke. From these are obtained 18 horsepower, quite sufficient for a vehicle of this nature, designed to carry comparatively small loads and be economical to maintain. Transmission is of the selective type, giving three speeds forward and reverse, clutch is leather-faced cone type with ball bearing spring thrust and ball bearing clutch thrust; drive is by propeller shaft and rear live axle. The pressed steel frame, made in the company's own factory, is mounted on semi-elliptic springs, 36 inches in front and 46 inches in the rear. Wheelbase is 101 inches and road clearance 9 inches. A very complete equipment comprises gas lamps, side and tail lamps, horn, generator, tools, etc. Total weight of the car is 1,400 pounds.

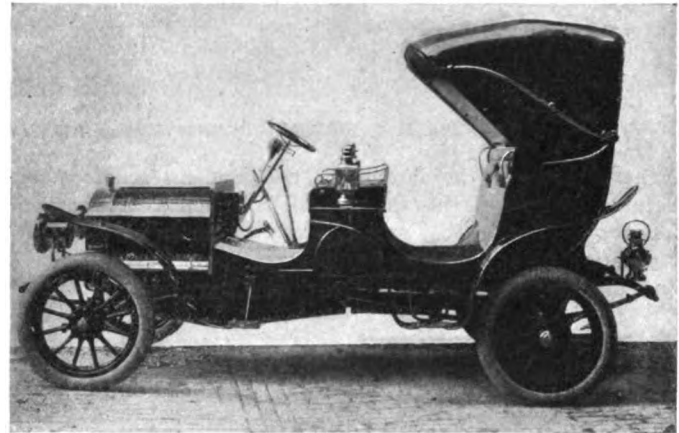

MODEL 8N STODDARD-DAYTON SPECIAL LANDAULET.

#### CLAIMS THE ECONOMY MILEAGE MEDAL.

"Fifty thousand miles in my 'Old Husky,' a Rambler 1904 Model, at a cost of only \$200 for upkeep," says W. W. Watts, a Los Angeles autoist. Mr. Watts is an architect and builder, and supplementing the above brief but rather pointed statement of his record, says: "I would like to challenge any American autoist to furnish proof of a better mileage and economy record. Thomas B. Jeffery & Company, Kenosha, Wis., manufacturers of the Rambler cars, will act as sponsors for Watts, who has deposited with them proofs of his mileage covered in four touring seasons, as well as an itemized account of his expenditures for maintenance.

By virtue of his record, which is the equivalent of twice round the world, Mr. Watts may demand the presidency of the Rambler Fifteen Thousand Club, an organization of Rambler owners who have driven the same Rambler car 15,000 miles or more. Mr. Watts purchased his car in Los Angeles in May, 1904, and, in a country where long trips are possible every day in the year, piled up an average of 12,000 miles very season, no obstacles being considered too great to be overcome. He says he will drive the "old tub" another season and maybe longer, so that by the time the old car finally gives way to a more modern successor, it will have achieved enviable records in more ways than one.

## SOUTH AMERICAN MARKETS FOR AMERICAN AUTOMOBILES

By J. A. LORD.

**F**EW of our automobile manufacturers are apparently aware of the excellent market for cheaper grades of cars which is open to them in most of the cities of the east coast of South America. If they are, it is unfortunate to be compelled to record that results show that they have not, up to the present, taken advantage of their opportunities. Few good roads are found in South America outside of the municipal limits, but most of the cities, which spread over large areas, have level, well-paved and shaded thoroughfares, affording excellent roadways for the automobile.

The South American likes anything showy, or stylish, or out of the ordinary, and a small business runabout either for two or four persons will find a ready sale. The ability to attend to business under circumstances different from general customs appeals to these fastidious peoples and the only reason why there are not more autos in use seems to be on account of the backwardness of our auto manufacturers in entering a field offering so many and good opportunities.

On the Amazon and its delta there are but two cities—Manaos and Para—likely to use the automobile. At Manaos, fifteen hundred miles from the Amazon's mouth, there are elegant streets to be found and many rich rubber merchants are ready and anxious to buy a good machine. At Para, one hundred and thirty miles from the mouth, most beautifully shaded streets lead out into the suburbs where are located the zoölogical garden and the Rodriques Alves Bosque, the latter being a park more beautiful and almost as large as Central Park.

Pernambuco could probably use a dozen machines of small cost on its shaded and fairly well-paved streets. There are a few good, but short, drives outside of the city limits. Further down the coast, San Salvador (or Bahia, as we know it), is a city which in reality is two cities. The commercial section is at sea level and the retail and residential section is on a level elevation reached by steep hills for wagons and elevators and inclines for passengers. At Bahia there are long, elegantly paved streets in the upper city, most of which lead to beautiful roadways extending along the ocean, affording magnificent marine views. There is no doubt but that our manufacturers would find a ready sale in this city.

But the best automobile markets, the ones from which large returns should be realized, are farther south at Rio de Janeiro, Petropolis and Sao Paulo in Brazil and Buenos Ayres in Argentine. Rio de Janeiro and its mountain suburb, Petropolis, will gladly welcome the advent of the American autos. European manufacturers have agencies at Brazil's capital, but their prices have been placed so high that they are almost prohibitive, though there are upwards of two

hundred autos, including two large auto 'buses, in use in Rio de Janeiro at the present time. Several auto 'buses are now in the course of construction and delivery. A two or four-seated car adapted to both business and pleasure and offered at the proper price is in demand at the present time both at Rio de Janeiro and Petropolis.

Sao Paulo and Bello Horizonte, the first the greatest coffee-growing center of the world and the latter the capital of the State of Minas Geraes, offer rich markets for the pleasure car builder. Sao Paulo has many rich coffee fazendeiros, or coffee growers, who would use their cars in regularly visiting their coffee fazendas or farms. Bello Horizonte's residents consist mostly of those natives who have become wealthy from Minas Geraes' resources. No earnest development of the State of Minas Geraes has been prosecuted up to the present time, and yet in a few years many poor people have become rich in simply "scratching the surface" of its precious stones, gold and silver.

No better market for a limited number of cars could be wanted than at Montevideo, the capital of Uruguay. Its miles and miles of modern streets connecting with the most magnificent country roads one wishes to ride over afford excellent trackage for automobiles. At Buenos Ayres and Rosario possibly the best American market is open to competition. There are many European cars here, and an old-world company is about to inaugurate a taximeter cab service in the former city. Nevertheless, the writer was asked many times while in Buenos Ayres, three months ago, why our American auto builders do not offer their products for sale in that city.

At Rio de Janeiro and Buenos Ayres and, to a limited extent in Montevideo, many auto freight trucks are needed. Rio de Janeiro should have a taximeter cab service at "popular" prices. An auto-'bus line similar to that which is in operation on Fifth avenue, New York, would net most satisfactory returns should it be put in operation on the main thoroughfare in Buenos Ayres. At the present time there is only one American car being pushed energetically in South America, and this demonstration has only been going on for about three months.

Our automobile manufacturers should investigate the possibilities open to them in this fertile field. Good returns will be realized if they will only have the courage and patience to fight against all kinds of apparent deterring contingencies which in the end are no harder to overcome than the troubles experienced and mastered in domestic trade, if the distance of six thousand miles is taken into consideration as the stepping stone between the producer and the consumer, and with agents on the ground this is not such a great obstacle.

### AMERICAN AUTO OMNIBUSES IN JAPAN.

United States Consul George H. Scidmore reports that the Soshin Motor Car Company began operations at Nagasaki, Japan, on November 4 with two auto omnibuses, manufactured by Knox & Co., of Springfield, Mass. The line of travel is confined to the level roads along the water front and up the valley to the suburb of Urakami, a distance of nearly three miles. An increase in the number of vehicles and length of route is expected at an early date. Owing to the very hilly surface and narrow and undeveloped character of the roads in this part of the Japanese island of Kiushiu, some time must elapse before improvements will permit an extensive use of motor vehicles. Their speed is restricted to eight miles per hour within city limits.

### TRIAL OF RENARD MOTOR ROAD TRAIN.

A report from U. S. Consul Alfred K. Moe states that there was recently tried in Dublin the new Renard road train, and that those interested in the problems of transportation in Ireland, apart from the railway companies, regarded it as having great possibilities for the development of the island.

"The difficulty of transportation, both as regards freight and passengers in Ireland, the high rates and fares, and the very inadequate service supplied by the railways, offers a choice field for the first individual or company with courage and money enough to develop a system which will give the people of Ireland a chance to become factors in the agricultural and industrial life of the country, from which they are at present excluded by excessive railway charges.

## "SHOW-ME" STATE AUTOISTS WILL TOUR SOME

ST. LOUIS, Jan. 20.—Thoughtful Missouri autoists are anticipating this year a period of reconstruction in the automobiledom of the State; for, since the death of the drastic motor vehicle law which only permitted the use of a motor-driven vehicle throughout the State for something like \$342 annually and the coming of a new law which gives an enlightened form of State registration, the man who drives

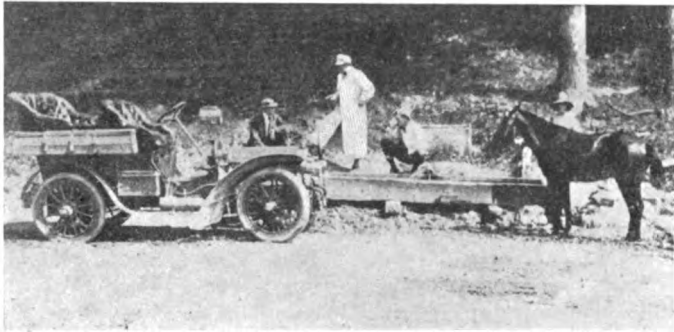

CRYSTAL SPRING SUPPLIES BOTH MACHINE AND BEAST.

a car in the "Show-Me" State has begun to feel emancipated. Since automobiling in Missouri has been healthy and vigorous in spite of opposition from farmers and indifferent roads—to say nothing of the law—there is every reason to believe, now that the sort of automobiling slavery which has been so hard to bear has passed, that the new order of things will bring forth conditions which will delight the tradesman and the enthusiast alike.

St. Louis autoists are still under the ban of a city tax of \$10 per year, but car owners have been paying this long enough to become accustomed to it, and it is as nothing compared to the restrictions of the past in the form of separate taxes for each county in which one wished to drive his car. St. Louis is peculiarly situated, so that it is not in any county, so that formerly whenever one wished to drive outside the city limits he had to be provided with a county license according to the direction in which he wished to go. To pass out of the city on the north or west, it was necessary to have a St. Louis county license; if he went South, he found that unless he had a Jefferson county license he would be held up by a deputy, or a constable, before he had journeyed far. To drive some fifty miles north, west or south he had to provide himself with other licenses. The annual cost of such county taxes varied from \$2 to \$3, according to the local interpretation of the law. In order to drive in every county in the State he was liable to a yearly tax, which at the rate of \$3 per county, amounted to \$342, and that amount did not include the city license.

The State registration act was not passed until after a hard three-years' fight on the part of the St. Louis and Kansas City clubs, and even when the victory came many autoists could scarcely realize it—they had almost become used to it. But they are fully awake to the possibilities of it now, and, the restrictions gone, they are looking forward to the spring and summer with better opportunities for exploring unknown roads and sections where the automobile has scarcely been seen. Those who have been in the habit of shipping their cars to the East for the summer months are contemplating changing their plans this season and see something of their own State under the new régime.

A well-known capitalist the other day was asking your

correspondent's advice about buying a new car for himself. "What do you want to use it for?" he was asked.

"I want a car that I can run to Kansas City with—one that will be comfortable and will stand up over Missouri roads. I am tired of touring around in the East, where there's a 'six-miles-an-hour' sign on every telegraph post and a police trap on every decent stretch of road."

Such is the new Missouri spirit.

Promise of future activity in out-of-town driving has been shown, since the enactment of the registration law, in the larger use of such splendid macadam highways as the De Soto pike—famous in the old bicycle days—the Manchester road, the St. Charles rock road, and the Gravois road. The De Soto pike and other roads in Jefferson county were practically boycotted by St. Louis automobilists under the old law because one county license was about all anyone cared to provide himself with, and St. Louis county was chosen because it provides the greatest number of good roads. Now the run to De Soto is one of the most popular, while many who in the past never crossed the Missouri river now push into St. Charles county and even beyond. The De Soto pike provides a splendid demonstrating run with its long hills. One section of this road is composed of two hills that form an acute angle, each leg of which is fully a mile long. If one drives through St. Charles county over dirt roads—with, possibly, a ford or two—and along the Quiver river bottom of Lincoln county, into Pike, he will find the justly celebrated roads of that county. A great many have been in the habit of avoiding the picturesque, though unreliable, route through St. Charles county by taking their cars on board a Mississippi river steamboat at St. Louis and landing at Hannibal.

Let it not be imagined for an instant that the automobilist in Missouri is free from the pestilence of the man with a deputy's commission in his pocket, who seeks to make a living off of automobile enthusiasm. His trade has been a lucrative one for several years, and the motor vehicle law, although favoring autoists, has not retarded his business. That the attitude of the country gentry is not as menacing or as violent as it was a year ago is, however, true, and the automobilists feel safer and in every way more comfortable outside the city limits than ever before.



TYPICAL MISSOURI ROAD LEADING OUT OF ST. LOUIS.

## THE AUTOMOBILE CALENDAR.

## AMERICAN.

## Shows and Meetings.

- Feb. 1-8.....—Providence, State Armory, Automobile Show. Frank M. Prescott, manager.
- Feb. 3-8.....—Kansas City, Mo., Convention Hall, Automobile Dealers' Association of Kansas City.
- Feb. 10-15.....—Detroit, Light Guard Armory, Tri-State Automobile and Sporting Goods Association, Seventh Annual Show.
- Feb. 17-22.....—Cleveland, Central Armory, Annual Show, Cleveland Automobile Dealers' Association. George Collister, manager.
- Feb. 21-29.....—Newark, N. J., Electric Park Auditorium, New Jersey Automobile Trade Association and New Jersey Automobile and Motor Club.
- Mar. 7-14.....—Boston, Mechanics' Building and Horticultural Hall, Boston Automobile Dealers' Association. Chester I. Campbell, manager, 5 Park Square.
- Mar. 11.....—Boston, Bay State Auto Association Clubhouse. First Quarterly Meeting, Society of Automobile Engineers.
- Mar. 9-14.....—Buffalo, Convention Hall, Sixth Annual Automobile Show, Automobile Club of Buffalo. Dal H. Lewis, manager.
- Mar. 21-28.....—Toronto, Canada, St. Lawrence Arena, Automobile Show. R. M. Jaffray, manager.
- Apr. 5-12.....—Montreal, Canada, Arena, Third Annual Automobile and Sportsman's Show. R. M. Jaffray, Mgr.

## Motor Boat Shows.

- Jan. 25-Feb. 1.....—Boston, Mechanics' Building, National Association of Engine and Boat Manufacturers. Chester I. Campbell, manager, 5 Park Square, Boston.
- Feb. 3-8.....—Buffalo, Convention Hall, First Annual Power Boat and Sportsman's Show, auspices of Buffalo Launch Club. Dal H. Lewis, manager.
- Feb. 20-Mar. 7.....—New York City, Madison Square Garden, Fourteenth Annual Motor Boat and Sportsman's Show.

## Race Meets, Hill Climbs, Etc.

- Mar. 2-7.....—Ormond-Daytona, Fla., Automobile Club of America.
- Mar. 16-21.....—Savannah, Ga., Savannah Automobile Club.
- Apr. 24.....—Briarcliff Trophy Race, Westchester County, N. Y. Robert L. Morrell, chairman.
- May 4-5.....—Harrisburg-Philadelphia and Return, 150-mile Endurance Run, Motor Club of Harrisburg.
- May 30.....—Bridgeport, Conn., Sport Hill Climb, Bridgeport Automobile Club.

## FOREIGN.

## Shows.

- Jan. 18-Feb. 2, '08—Turin, Italy, Fifth International Automobile Exhibition, Palace of Fine Arts, Valentino Park, Automobile Club of Turin.
- Mar. 21-28.....—London, Agricultural Hall, Cordingley's Show.
- May 6-20.....—Moscow, Russia, International Automobile Exposition, Automobile Club of Moscow.

## Race Meets, Hill Climbs, Etc.

- April 1-13.....—Monaco Motor Boat Races and Motor Boat Exhibition, International Sporting Club of Monaco.
- April 25-May 26—Industrial Vehicle Competition, Automobile Club of France.
- May.....—Paris, Competition for Agricultural Automobiles, auspices of "L'Auto." (Date to be announced.)
- May 10.....—Sicily, Targa Florio, Automobile Club of Italy.
- June 1-18.....—Reliability Trials for Pleasure Cars, Automobile Club of Great Britain.
- June 9-17.....—Touring Competition for the Prince Henry of Prussia Prize, Germany, Imperial Automobile Club of Germany.
- July 1-15.....—Grand Prix, Dieppe Circuit, Automobile Club of France. (Exact date to be announced.) Single and two-cylinder runabout race on preceding day.)
- July 13-17.....—Ostend, Belgium, International Race Week, Automobile Club of Ostend.
- July 20-30.....—Ardennes Circuit Races and Coupe de Liedederke, Automobile Club of Belgium.
- Aug., 1908.....—France, Coupe de la Presse, Automobile Club of France. (Exact date to be announced.)
- Aug. 29-30.....—France, Mont Ventoux Hill Climb, Vauclusien Automobile Club.
- Sept. 1-8.....—French Voiturette Contest, auspices of "L'Auto."

## BOOKS FOR AUTOMOBILISTS.

**A. L. A. M. Fifth Annual Handbook.**—One hundred and fourteen different models and types of cars are shown in the fifth annual handbook published in an improved and more handsome form by the Association of Licensed Automobile Manufacturers. The descriptions and illustrations deal with all American cars licensed under the Selden patent, as well as the leading foreign firms importing under the same license. The specifications include standard color, seating capacity, clutch, wheelbase, tire dimensions, number of brakes, cylinders, ignition, transmission, power and price. For the first time the horsepower rating adopted by the mechanical branch of the association last year is given in the handbook, a page being devoted to this, calling attention to the basis of the formula and how horsepower can be computed at a glance. Though the formula was produced to act as a commercial rating, there is no reason why it should not be employed equally well for contests of any nature. Eighty per cent. of the cars shown in the book have adopted this method of computation, and it is expected that in next year's handbook all the members will have adopted this formula as their standard.

**An Aeronautical Textbook.**—Herbert Chatley, in his textbook on "The Problem of Flight," published by the J. B. Lippincott Company, of Philadelphia and New York, has tackled the difficulties of aerial navigation from the standpoint of the engineer. There is little in the book that will appeal to the dabbler or the man interested in aeronautics as a possible field of sport. To the serious student, however undismayed by mathematical analysis, there is plenty of substantial food. Dirigible balloons of the lighter-than-air type receive but a small amount of attention compared with the consideration of aeroplanes and aviplanes, the author evidently rightly considering that it is in the realm of the heavier-than-air type that the real solution of the problem will eventually be found. It might be objected that too much space has been wasted on storage batteries and gasoline engines of a type little suited for aerial navigation, while practically no attention is paid to the several light-weight aerial motors successful in public tests. The volume is freely illustrated by line drawings and half-tone illustrations.

**Touring Through Italy.**—Art overrules all in Dan Fellows Platt's "Through Italy with Car and Camera," a handsome illustrated volume published by G. P. Putnam's Sons, New York and London. But as the author wisely remarks in his preface, a study of the world's finest art treasures being the main feature of every right-minded visit to Italy, no excuse is needed for the many references to pictures, statuary and architecture. There is much more of the artist than the automobilist about the volume, but even the most enthusiastic and sporty driver will not object to be free from the odor of gasoline in the persuasion of the volume. There are sufficient glimpses of scenes along the road to make the volume interesting as an account of travel by automobile, but for the person interested in the wealth of art of the country and desirous of seeing it in the most pleasing manner, no better volume could be recommended.

**A German Automobile Handbook.**—"Automobiltechnischer Kalender," a handbook of the automobile industry for 1908, is a compact, closely-printed volume of nearly seven hundred pages, from the publishing house of M. Krayn, Berlin. Completeness, amounting almost to elaborateness, is a feature of the Teutonic work, the machines described and parts analyzed in detail being, with very few exceptions, those of current models. The German industry is naturally the one occupying the major part of the publication, though French models are given some attention. Engineering tables are a strong feature of the book.





Vol. XVIII Thursday, January 23, 1908 No. 4

THE CLASS JOURNAL COMPANY

Flatiron Building, Madison Square New York City

H. M. SWETLAND, President

EDITORIAL DEPARTMENT

A. G. BATCHELDER, Managing Editor R. F. KELSEY, Associate Editor C. B. HAYWARD, Engineering Editor W. F. BRADLEY

BUSINESS DEPARTMENT:

A. B. SWETLAND, Business Manager LOUIS R. SMITH FRANK B. BARNETT W. I. RALPH, 1035 Old South Building, Boston, Mass. H. GURNETT, H. E. WESTERDALE, 836 Monadnock Block, Chicago, Ill.

Cable Address - - - - - Autoland, New York 047 Distance Telephone - - - - - 300 Gramercy, New York

SUBSCRIPTION RATES:

United States and Mexico - - - - - One Year, \$3.00 Other Countries in Postal Union, including Canada - - - - - One Year, 5.00 To Subscribers—Do not send money by ordinary mail. Remit by Draft, Post-Office or Express Money Order, or Register your letter.

FOREIGN SUBSCRIPTION AGENTS:

ENGLAND:—Hilffe & Sons, Limited, 20 Tudor Street, London, E. C. FRANCE:—Boyveau & Chevillet, 22 Rue de la Banque, Paris. GERMANY:—A. Seydel Mohrenstrasse 9, Berlin.

Copyright, 1907, by The Class Journal Company. Entered at New York, N. Y., as second-class matter. The Automobile is a consolidation of The Automobile (monthly) and the Moto Review (weekly), May, 1902, Dealer and Repairman (monthly), October, 1903 and the Automobile Magazine (monthly), July, 1907.

Table with 2 columns: Year, Copies printed. 1905: 730,000; 1906: 791,000; 1907: 888,000.

A Good Roads Suggestion of Great Promise. New York State has authorized the expenditure of \$101,000,000 for the building of a modern waterway, much of which simply enlarges the route of the famous Erie Canal.

By taking advantage of the bed of the canal a vast amount of preliminary work and its cost would be avoided, and as the route of the canal is naturally characterized by long, straight stretches and sweeping curves of large radius, the actual rise to be overcome being so small that when distributed over but a small portion of the available distance, the grade would be imperceptible.

Seller Now Sensibly Considers the Buyer's Rights. "When did we go out of the automobile business and enter the highway robbery line?" asked one of America's foremost automobile manufacturers of his superintendent, upon discovering, quite by accident, that the prices which were being charged for replacement parts of his cars would, if totaled, amount to fully three times the list price of the complete automobile.

Just why new parts to rebuild the same machine should cost several times more than the manufacturer found it possible to put the complete car out for with a good profit originally was one of the enigmas of the erstwhile automobile "game." Actually it was an outgrowth of the same pernicious practice that brought some manufacturers of bicycles into disrepute in earlier days.

The relation between buyer and seller does not end with the completion of the purchase, and subsequent courteous treatment does more to cement it and make of its recipient an assured future customer than all the blandishments the salesman can bring to bear.

Will the 1908 Models Be the Last "Annuals"? Though the futility of attempting to bring forth a new car with the passing of every twelvemonth, in order to meet the misguided demand of the comparatively few, was recognized some time prior to the holding of the recent shows, this seemed to be the first occasion on which any public reference was made to it.

The most successful cars on the market to-day are those that only differ from year to year in those small points, the betterment of which is the result of experience. While such cars are nominally new models, and are known to a large extent by the year of their production, their makers are always at pains to point out that successful precedents have not been swept away in favor of something new and untried, and that the car is merely an improved successor of its forerunners.

**TAXICABS FOR THE MONUMENTAL CITY.**

BALTIMORE, Jan. 20.—The taxicab, which has proven so popular in New York, London and Paris, will make its debut in this city on the first of April. The taxicabs will be introduced in this city by Howard Gill and A. Stanley Zell, of the Motor Car Company. The machines have been ordered from the E. R. Thomas Motor Company, of Buffalo, and are expected to be delivered in this city about the first of April, when they will be placed in service. Should they prove a success more will be ordered. Baltimore will be the second city in this country to put these cabs into service.

**FREIGHT RATES DISCUSSED WITH RAILROADS.**

Alfred Reeves, general manager of the American Motor Car Manufacturers' Association, and James S. Marvin, traffic manager of the Association of Licensed Automobile Manufacturers, attended a conference last Tuesday, at Hot Springs, Va., at which freight rates for automobiles was discussed with the Western Classification Committee. Among other things considered was the minimum weight to be applied on carload shipments of automobiles, and also the minimum weights to be applied on less than carload shipments. The Western Classification Committee governs freight rates on all lines west of Chicago. The matter is an important one to the whole industry, any benefits which can be obtained being advantageous to manufacturer, agent and user alike.

**DURYEA TRUSTEE UPHeld BY COURT.**

READING, PA., Jan. 20.—When the matter of electing a trustee in bankruptcy for the defunct Duryea Power Company of this city came up, Referee Samuel E. Bertolet would not allow the claim of Herbert M. Sternbergh, president of the company, to be voted, on the ground that Mr. Sternbergh was not a creditor, but in reality owed the concern \$26,000 on his stock subscription. This prevented the election of the trustee favored by him, the Berks County Trust Company then having a majority of claims in both number and value, and the contention of the referee and the election held under it has just been confirmed by Judge McPherson, sitting in the United States District Court. The matter of adjusting the bankrupt's affairs has been held up in the meantime pending this decision, but the trust company will now proceed to settle matters without further delay. It is also stated that an action will be brought against H. M. Sternbergh to compel payment of the \$26,000 due on his stock subscription.

**JERSEY'S SHOW TO BE NOTABLE AFFAIR.**

NEWARK, N. J., Jan. 20.—New Jersey autoists are displaying lively interest in the preparations being made for the holding of the State's first automobile show at Newark during the week of February 21 to 29. The exhibit is to be held in Electric Park Auditorium, in South Orange avenue, this city, which is the largest exhibition hall in New Jersey outside of the National Guard armories.

The officials of the New Jersey Automobile and Motor Club are cooperating with those of the New Jersey Automobile Trade Association in the management of the show. The former organization has a membership of over 800, and is the strongest organization in New Jersey. The Trade Association is composed of dealers from all over the State, and is also a very strong body.

No money is being spared by the management to make the affair impressive and spectacular. More than \$2,000 will be spent in decorations alone, and several features have been announced, including a Governor's night, when four of the Chief Executives of the State, past and present, will probably attend, a club night when the Associated Automobile Clubs of New Jersey will attend in a body, and a "society night."

**CREDITORS TRAIL "STOP THIEF" CRYER.**

NEW HAVEN, CONN., Jan. 20.—John E. Fulton, president of a concern known as the Connecticut Automobile Company, which opened for business in this city about the first of the year, left town suddenly some time last night and the police with an army of creditors are hot on his trail. The concern, of which Fulton was the head, is surrounded by a great deal of mystery. It occupies one of the largest factories in this city, having over 80,000 square feet of floor space and was formerly occupied by the National Folding Box and Paper Company. Fulton announced that his company would put three styles of autos and commercial cars on the market to sell at \$350 each. He announced that the cars would cost less than \$250 to build, and would excel some machines selling at \$2,000. He advertised extensively, using full-page advertisements in the newspapers, which had as a catch line, "The Robbers Are On the Run."

It now develops that though some fifty men were employed, not one machine was built by this company nor were any orders taken. With Fulton was his son, a young man about twenty-five years of age, who was represented as being the inventor of certain machinery which enabled the company to turn out autos at the low price advertised. Fulton left creditors in this city who represent an aggregate of about \$5,000 in claims.

**TO AMEND LIEN LAW TO COVER AUTOS.**

ALBANY, N. Y., Jan. 20.—Assemblyman Weinert, of Buffalo, introduced to-night a bill to amend the lien law in order to make it cover automobiles in the hands of garage keepers and repairmen, for as things stand at present, where the car has been allowed to go out of his possession, no matter for how short a period, a lien cannot be enforced against it to collect for repairs or storage. The proposed new section reads as follows: "A person keeping a garage, or a place for the storage, maintenance, keeping or repair of motor vehicles, as defined by the Motor Vehicle Law, and who in connection therewith stores, maintains, keeps, or repairs any motor vehicle at the request, or with the consent of the owner, whether such owner be a conditional vendee, or a mortgagor remaining in possession, or otherwise, has a lien upon such motor vehicle for the sum due for the storing, maintaining, keeping or repairing of such motor vehicle, and may detain such motor vehicle at any time it may be lawfully in his possession until such sum is paid." It was referred to the Committee on General Laws.

**ROADS TO BE BUILT AND BOOMED IN UTAH.**

OGDEN, UTAH, Jan. 20.—The Utah Good Roads Association has completed its organization and arranged its plans in such a way that it will have to be reckoned with in politics at the next election. At an enthusiastic meeting held at the Weber Club a few days ago the articles of incorporation were formally adopted and a resolution was passed favoring the Brownslow good roads bill now before the Congress. Plans were discussed for the raising of a fund to build a State road across Davis, Salt Lake, and Box Elder counties. Local branches will be formed in these counties.

**FATALITY FOLLOWS SKIDDING IN PROVIDENCE.**

PROVIDENCE, R. I., Jan. 20.—While going slowly round a sharp curve near Oakland avenue, a big touring car owned and driven by R. Lincoln Lippitt, a member of the Racing Board of the A. A. A., skidded and struck a telegraph post. George H. Mercer, a cotton broker, who was riding in the car, was thrown to the street by the force of the compact, suffering a fracture of the skull from which he died three hours later in Rhode Island Hospital.

### TESTS OF HEAT GENERATED BY TIRES.

Henry Souther, metallurgical expert of the Association of Licensed Automobile Manufacturers, has recently been employed on experiments to ascertain the comparative heating properties of different types of automobile tires. To get accurate measurement two thermometers were used and inserted by drilling holes through the wooden felloe and metal rim of the wheel, and using a steel case opening on the lower end, in which the thermometer was inserted. The case had a cap projecting through the felloe, allowing the thermometer to be placed in contact with the tube.

A road test was made on a run from the Engineers' Club to Long Island City and from there to Patchogue, L. I., over roads which at times allowed a speed of 48 to 52 miles an hour. A Dow non-deflation tube and an ordinary inner

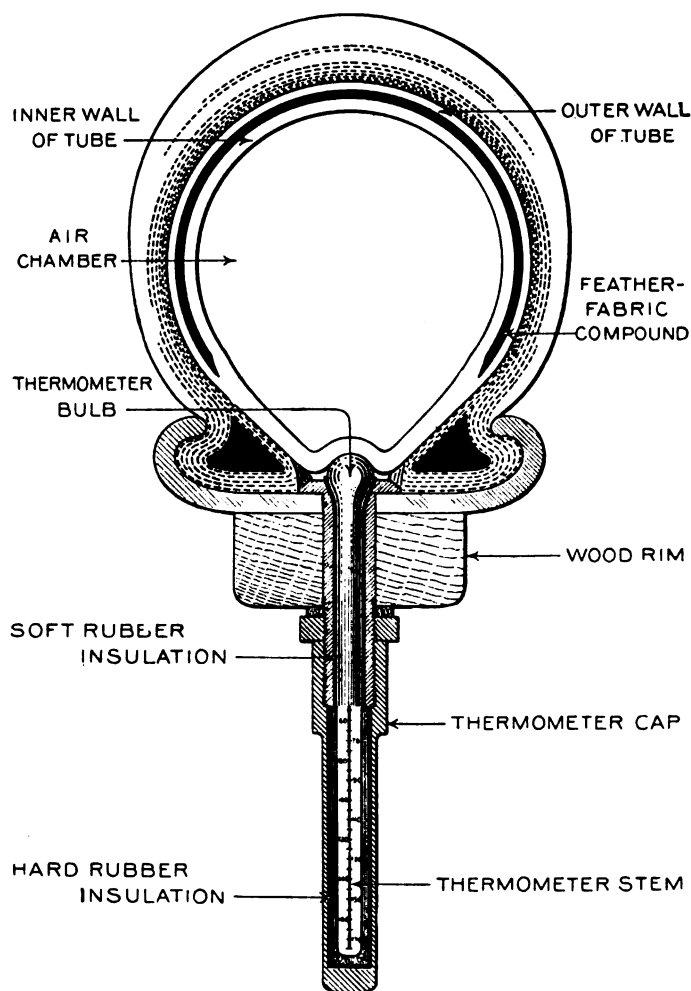

#### HOW THE THERMOMETER WAS USED TO READ HEAT WITHIN TIRE.

tube were under test. Mr. Souther, reporting the result, says:

"The test conclusively proved that the Dow tube runs cooler than any ordinary inner tube, though just how much cooler this would be in hot weather I am not prepared to say. By my method of summarizing, in hot weather, with the temperature of 70 degrees Fahr., the increase would be for the regular inner tube 60 per cent., or 42 degrees Fahr., making a total temperature of 112 degrees Fahr., whereas from the results of my experiments I find an increase in the temperature of 45 per cent. in the non-deflation type, making it only 101 degrees Fahr. under the same conditions.

"In the non-deflation type there is more material than in the simple tube, caused by the double walls and the plastic material between them which prevent its deflation. Many believed that the Dow on this account would run hotter; I believe that view erroneous in view of the tests made."

### NOTHING BUT OPTIMISM IN THE NORTHWEST.

MINNEAPOLIS, Mo., Jan. 20.—There is nothing of the "calamity howler" about President Chase, of the Chase Automobile Transfer & Livery Company, who has recently resigned as general manager of the Maxwell-Briscoe-Chase Company, of Chicago, and returned to this city. "I believe that the Northwest is the surest and safest place in the United States in which to do business," he declares. "While the East was suffering on account of the financial flurry in October, I ordered fifty automobiles for immediate shipment, and I wish that I had made it one hundred. I have delivered more automobiles thus far this month than I have any January since I have been in business, and if trade continues it may be the best month I ever had. I feel sure that this is going to be a banner year in the automobile business.

"I hope soon to surprise my friends with a new machine which will be built in Minneapolis. The engine, transmission and rear axle are now completed and being tried out, and inside of a year I hope to have a car made in Minneapolis that will be a credit to the city."

### HOW A FRANKLIN AGENT SUPPLIED PROOF.

PHILADELPHIA, Jan. 20.—Nettled at the hard luck which attended his cars in the recent endurance run of the Quaker City Motor Club, President Percy L. Neel, of the Quaker City Automobile Company, took a decidedly risky chance last week when he sent a 28-horsepower Franklin over the 172-mile course for three successive days. The test started on Monday last, and was carried through to a successful conclusion under the same rules as governed the New Year's endurance test, which, however, called for a two days' schedule. Official observers representing various local dailies were in the car each day. The Franklin acted splendidly throughout and succeeded in finishing without a single road penalty. As a final test of the air-cooled principle of the Franklin, the car was placed in the steam-heated salesrooms immediately after the last day's trip, and the engine was run without stop until 6 o'clock the following night—a continuous run of 34 1-2 hours—without a semblance of "heating up."

### THOMAS EXAMINED BY QUAKER COMMITTEE.

Editor THE AUTOMOBILE:

I note in the January 9 issue of your journal, where you give the results of the endurance run of the Quaker City Motor Club, that the 60-horsepower Thomas car in class B, driven by me, is marked as not examined by the technical committee. I want to say that this machine was examined by Charles Swain, a member of the technical committee, and was pronounced absolutely perfect. Mr. Swain is the president of the Quaker City Motor Club, and I do not understand how this information was given out as to the car not being examined.

We also note that you are giving another car the credit for being the first car to finish the run in Philadelphia, where, as a matter of fact, the Thomas was the first car to finish the run, being 32 minutes ahead of the schedule and 8 minutes ahead of any other car in the contest.

Reading, Pa.

E. S. YOUSE.

### ANOTHER MUNICIPAL CAR FOR INDIANAPOLIS.

INDIANAPOLIS, IND., Jan. 20.—Another step toward equipping all of the various city departments with automobiles has been taken in the order placed for an automobile to be used by Chief C. E. Coats, of the fire department. After considering the matter for several weeks, the Board of Public Safety has ordered a 1908 model Marion runabout, the contract price being \$2,250. Chief Coats informed the board that he preferred a home-made gasoline car. Several months ago the board purchased a White steamer touring car and an Autocar runabout, and will receive a Rapid patrol wagon before the end of the month. The city engineering department has been provided with a Ford runabout.

## CLUB ACTIVITIES BOTH WEST AND EAST

### CALIFORNIA WOMEN AUTOISTS MEET TO LISTEN.

SAN FRANCISCO, Jan. 15.—The California Women's Automobile Club recently held its first meeting for the year. After months, in fact before the great fire, this club has been in existence in name only, it seemed almost impossible to get the members together, but those who had the welfare of the organization at heart never tired in their work, even when meeting after meeting was only attended by a few. These must have felt great satisfaction when the recent event was over. The clubrooms of the California Women's Automobile Club were crowded to the doors, many having to stand in the hallway. The occasion was the regular monthly meeting, and, as an innovation, the officers had sent word that a lecture would be given on the subject of ignition. For a couple of hours the women autoists listened to an expert, who covered the subject most fully. When adjournment was taken, several remarked of the pleasures of

### APPEALS FOR FEDERAL REGISTRATION.

PHILADELPHIA, Jan. 20.—S. Boyer Davis, chairman of the legislative committee of the Pennsylvania Motor Federation, has addressed the following letter to Pennsylvania automobilists concerning the Federal registration measure, introduced in Congress by the Legislative Board of the A. A. A.:

#### FEDERAL REGISTRATION.

Every autoist who tours beyond the confines of his own State realizes the advantages he would derive from Federal registration, obviating the annoyance and expense of securing a license in any State except that wherein he resides.

Such a bill was prepared by the American Automobile Association and reintroduced during the present session of Congress and referred to the Committee on the Judiciary. If it is to become a law the autoists of the country must show that there is a strong demand for it.

We must do our part in Pennsylvania, and you are earnestly urged to write a personal letter to your member of Congress, requesting him not only to favor this bill himself, but to use his influence to



CALIFORNIA WOMAN'S AUTOMOBILE CLUB IN FRONT OF CLUB QUARTERS, SAN FRANCISCO, ON OCCASION OF FIRST GATHERING IN 1908.

the occasion and announced their intention of being present during the winter months, when these lectures are to be continued. During the first part of the meeting, Lady Beatrice Montagu, the president and founder of the Woman's Club of London, was elected an honorary member of the club. This is a compliment conferred on the British organization for the honor bestowed upon Mrs. Fred J. Linz, president of the local club, who was made an honorary member of the London club some time ago.

### MARYLANDERS WILL ADMIT LADY MEMBERS.

BALTIMORE, Jan. 20.—Owing to the increasing number of fair devotees of the automobile, the Maryland Automobile Club found it expedient at its last meeting to take down the barrier and admit the gentle sex to membership. This decision was reached after some consideration relative to the consequences, and it was practically decided that in order to amplify the social features of the club the presence of the ladies would be necessary. The main reason for admitting them to membership was that women relatives of club members might join the club. In doing this the Maryland Automobile Club goes on record as one of the first in the country to make such a radical change. Though this is something that practically all of them will have to come to sooner or later, in view of the numbers of women autoists,

secure for it prompt and favorable consideration. Write not only yourself but induce others, motorists or not, to do so; especially men of influence and personal acquaintances of your congressman. We are particularly anxious to have such letters go to members of the Committee on the Judiciary. Do this at once.

In your letters please state that a bill providing for the Federal registration of motor vehicles has been introduced by the American Automobile Association, and call attention to the facts that the demanding of license fees in so many States from automobile users of interstate highways is not only an imposition financially and interferes with travel from one State to another, but results in much annoyance and often in the arrest and fining of many persons who through ignorance of the varying requirements have failed to comply with the laws of some State. That Federal registration in addition to that required in the State wherein the motorist may reside will relieve tourists of this great and unnecessary annoyance and place a reliable means of identification upon motor cars instead of the confusion incident to the requirements of some States. That as only a uniform method of registration and identification is sought in this law the right of States to regulate the use of motor vehicles is not encroached upon and that it will result in small trouble or expense to the Government and bring in a revenue far in excess of such expenditure.

S. BOYER DAVIS,  
Philadelphia, Chairman Legislative Committee.

### A. C. OF KANSAS CITY DINES AND TALKS ROADS.

KANSAS CITY, MO., Jan. 20.—An elaborate banquet at the Midland Hotel—the second annual of the Automobile Club of Kansas City—did not prevent a lot of interesting discussion on good roads and other subjects of a kindred nature



dear to the heart of the automobilist. Ninety-four members of the club and guests did honor to the autofied fare and listened to the ten speeches of as many speechmakers. Curtis Hill, State Highway Commissioner, pointed out how a rock road system must be built up from the dirt roads of the State.

"The new State law providing for the establishment of benefit districts and the assessment of acre property along either side of the highway has been our greatest help. State highways will be built only by developing roads in the various counties and communities independently and connecting the links."

Numerous examples of how this was being done were given by Mr. Hill, and the plan outlined for the spending of the two and one-half to three million dollars a year now devoted by the State of Missouri to roads in a manner which would give proper supervision. A feature of the menu of the banquet was a map of the State showing the rock roads already constructed and those of a dirt nature in existence.

#### A. C. OF PHILADELPHIA BUSY SIGNBOARDING.

PHILADELPHIA, Jan. 20.—The roads and tours committee of the Automobile Club of Philadelphia, under the chairmanship of Powell Evans, is doing a splendid work in signboarding the various main routes leading out of this city in almost every direction. Although the Jersey roads are generally well equipped in the matter of road signs, the club's workers have found a few points where additional markers can be placed to advantage, and have arranged to supply the deficiencies. Northeastwardly toward New York via Trenton, about half the distance to the metropolis, has been posted. Northwardly the work has progressed far beyond Doylestown, and the Delaware Water Gap will be reached before midsummer. Northwestwardly to Reading and Harrisburg, the work is also well under way, while in a westwardly direction the roads to Gettysburg via Lancaster and York are being studied with a view to securing temporary alternative routes pending the improvement of several particularly bad stretches.

Another feature of the roads and tours committee's work is the laying out and posting of the best roads connecting the four principal routes, named at points in some instances as far as twenty-five miles from this city. Thus a well posted Trenton-Doylestown route would be a godsend to many an ignorant automobilist who, rather than take chances of losing his way, might prefer to come down to Philadelphia and thence to Doylestown over familiar roads. A Doylestown-Pottstown or a Doylestown-Norristown route distinctly laid out and signboarded would be an equal convenience, as would be a Pottstown-Downingtown route.

It is in line with the club's general scheme of road marking that the Automobile Club of Delaware County is being helped along in its good roads work in the hope of eventually securing a direct route to Baltimore. When this much-to-be-desired end gives promise of being attained, the club's signboarding work will be instituted along this route also, with a cross-county connecting route from Coatesville to Avondale or Oxford.

#### QUAKERITES TO HAVE NEW OFFICERS.

PHILADELPHIA, Jan. 20.—The annual meeting and election of the Quaker City Motor Club will be held Thursday, February 6, at the Hotel Majestic. While an entirely new set of officials will be elected, there will be but two contests—that for the office of secretary between the present occupant of that office, H. C. Harback, and Isaac K. Minford, and the usual fight for places on the board of directors. Following is the list of nominations: For president, P. Donald Folwell; for first vice-president, A. T. James; second vice-

president, L. D. Berger; treasurer, A. T. Stewart; for secretary, H. C. Harback and I. K. Minford; for board of directors (nine to be elected): G. Douglas Bartlett, E. C. Johnson, C. J. Swain, G. Hilton Gantert, E. H. Fitch, E. A. Maltby, E. C. Leeds (all present members), J. R. Overpeck, Evans R. Church, Frank Hardart, M. E. Brigham, Dr. W. J. Donnelly, F. C. Vanderhoff, B. F. Paist, L. E. French, Nicholas Petry, D. W. Webster and George M. Graham.

#### EARLY PLANNING FOR HARRISBURG'S RUN.

HARRISBURG, PA., Jan. 20.—Tentative plans and rules for the annual endurance run of the Motor Club of Harrisburg, which will be held on May 4 and 5, were made last week when R. H. Johnston, of New York, who will act as referee, held a long conference with the members of the contest committee. The route selected will cover eastern and central Pennsylvania, with the night stop in Philadelphia. Leaving this city on the first day the contestants will proceed via Lebanon, Reading, Kutztown, Allentown, Easton, Doylestown to Philadelphia, a distance of 167 miles. On the return trip the cars will pass through Norristown and on to Reading, across to Lancaster, Columbia, Marietta, Mt. Joy, and back to Harrisburg, a distance of 144 miles.

The rules for the contest will be far more strict than for any like run ever held in the East.

#### TOLEDO'S CLUB ONLY REQUIRES GOOD ROADS.

TOLEDO, O., Jan. 20.—The Toledo Automobile Club, which is just being organized, lays claim to being one of the most unique and original clubs of its character in the United States. Membership is not dependent upon owning an automobile wholly or in part, but the qualifications for membership are an interest in the good roads movement and a desire to help boom Toledo. In regard to the first, there is no section of Ohio which is better located for good roads than Lucas county, wherein Toledo is located, for substrata and surfacing materials are in plenty and nature's own gift, while in the second place it is the intention of the organization to work with the Toledo Chamber of Commerce for a larger and greater Toledo.

The club has just received notification of its affiliation with the American Automobile Association.

#### WEST VIRGINIA TO FORM STATE ASSOCIATION.

WHEELING, W. VA., Jan. 20.—The Ohio Valley Automobile Club has decided to devote its attention to the formation of a State organization of automobile owners in West Virginia to become affiliated with the American Automobile Association. At present the clubs have no central organization, while even many cities have no organized clubs. Indeed, the only two permanent organizations are at Wheeling and Martinsburg. As Parkersburg is the most central point in the State, it has been selected as the meeting place for the convention, the Chancellor Hotel to be headquarters for the present. Much attention will be paid by the State organization to the question of suitable legislation on the use and control of automobiles.

#### A. C. A. MEMBERS ATTEND INTERESTING TALK.

NEW YORK, Jan. 22.—After the regular club dinner at the West Fifty-fourth street home of the Automobile Club of America, last Tuesday evening, J. Dunbar Wright delivered an illustrated lecture on a "Trip Round the World" before a large number of members and guests. Many of the 200 lantern slides shown during the talk on travels had been taken by the lecturer himself during his journeys round the world, and the numerous incidents of personal adventure connected with them added greatly to the interest of the lecture.



THOMAS 1908 SIX-CYLINDER LIMOUSINE FURNISHES SMOOTH RUNNING, COMFORT, AND LUXURIOUS TRAVEL.

**PIONEERING THROUGH FLORIDA.**

**T**HERE will be a chance for the sand and mud pluggers to prove their worth in the 366-mile run from Jacksonville to Miami, Fla., to be organized by the Florida East Coast Automobile Association the second week in March. Plans have been completed for James Laughlin, 3d, to leave Jacksonville on the morning of January 22 on a pathfinding trip over the land to be invaded. The 45-horsepower Cleveland car to be used on the trip will be fully equipped with pick-axe, spade, block and tackle, 18-foot pine skids, rolls of canvas and necessary camping outfit. Those accompanying Mr. Laughlin will be Vice-president George E. Sebring, of the Florida East Coast Automobile Association, and Sales Manager Charles G. Percival, of the Cleveland Motor Car Company. Their task will be to survey and lay out the 360 miles of swamp and everglades lying between the untraveled depths from Jacksonville to Miami, this district never having been completely covered by an automobile. Signboards will be erected at every point where their presence is likely to be valuable to the tourists.

The main body, expected to include a large proportion of the members of the Florida Association having their cars at Daytona, will spend five days in their trip down the

coast. Starting from Bay and Hogan streets in Jacksonville, Ormond will be the first objective point, a stop being made for lunch at the Alcazar in St. Augustine. An interesting portion of the journey will be that over the old King's highway out of St. Augustine, now being put into good condition by a gang of men under the personal supervision of Thomas White, father of Windsor White of Cleveland. Rockledge, 175 miles out, will be the stopping place at the end of the second day's run, half of the 71 miles being over very rough country with only a trail to show the way.

Fort Pierce, at the end of the third day, will have a rousing reception for the whole of the tourists and a silver cup to hand over to the driver of the car first striking the city. The trophy has been secured by the efforts of the Fort Pierce News; the reception will come from the entire town. Barren wastes, some creeks and possibly a little bridge building being the order of the going from Fort Pierce, it is considered that the 67 miles to West Palm Beach will be all the mileage that the contestants will be able to accomplish between sunrise and sunset. For a portion of this distance there are only rough trail made by wagons with a 60-inch tread. During the last stretch into Miami narrow limestone roads will be met, and comparatively easy going found, while the country is of the most beautiful nature.

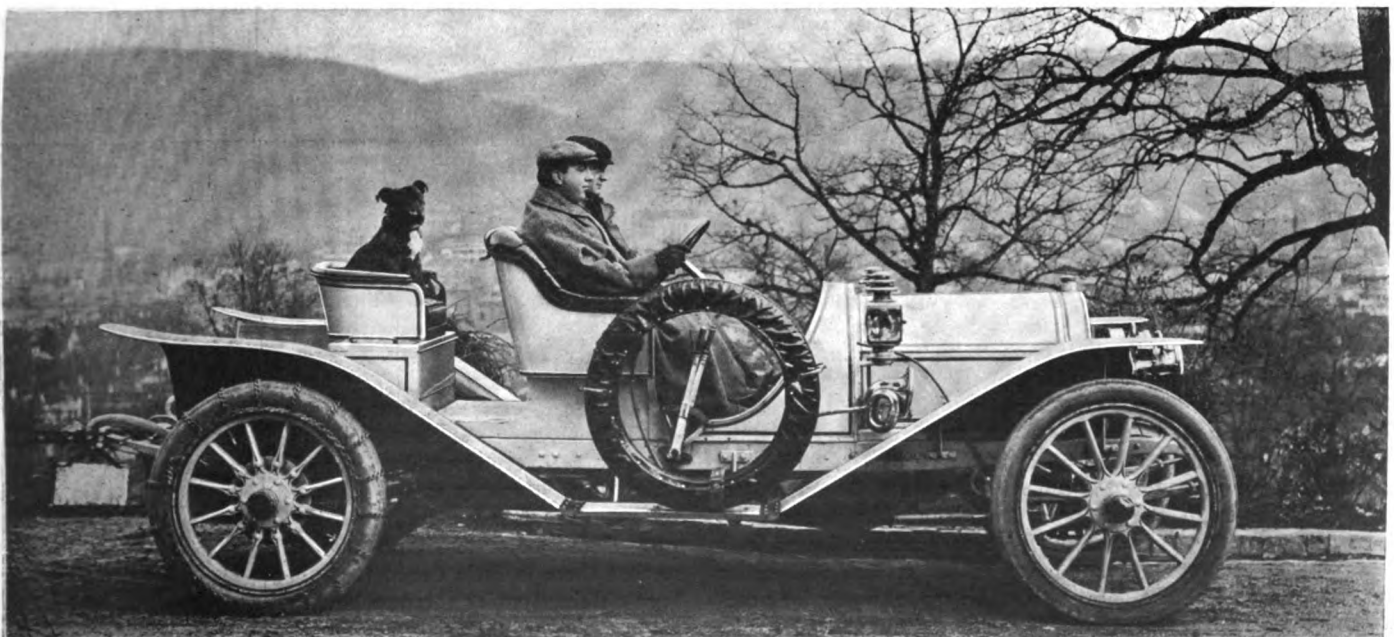

MAJOR C. J. S. MILLER AND HIS AMERICAN LOCOMOTIVE CAR (LICENSE BERLIET), A MIGHTY HILL CLIMBER AROUND FRANKLIN, PA.

## BAY STATE LEGISLATORS HAVE MANY AUTO BILLS

BOSTON, Jan. 20.—There is no rest for the legislative committees of the automobile clubs and associations in Massachusetts this winter, for during the next few months it looks as if they would have to pay close attention to the doings of the Legislature. The time for filing bills expired to-day, and about a dozen different measures have been entered, while others may be filed later by special permission. Every year since 1903, when the first automobile law was passed, the Great and General Court has amended and added to the existing statutes governing motor vehicles, and apparently the process is to be continued this winter and along varied lines.

The Safe Roads Automobile Association, which is composed largely of owners of cars, and the main object of which is to prevent improper use of cars and protect from reckless drivers of automobiles pedestrians and other users of the highways, has filed no less than eight bills, while from other sources have come other measures, including a petition from Nantucket that it be exempted from the application of the general law and that any rules which the Selectmen may make be final and not subject to appeal to the Highway Commission. This is intended to make valid an automobile exclusion rule which the town authorities have tried in vain to enforce.

### All Vehicles Shall Carry Lights.

The measure requiring that all vehicles using the roads after dark shall carry a light or lights, which has been before the Legislature for several seasons and which annually has been turned down, has appeared again. There is an independent bill entered for this purpose and one of the Safe Roads Association's bills covers the same point. Another bill of the association intended to improve the rules of the roads provides that all vehicles must keep to the right whenever any other vehicle is in sight and whenever, as on corners, the view is obstructed for 100 yards in advance. This bill also provides that a vehicle must not pass another going in the same direction unless the driver of the vehicle wishing to pass has an unobstructed view ahead and can pass without interfering with a vehicle coming in the opposite direction.

### Investigators of Accidents.

The most novel proposition before the Legislature is contained in one of the bills of the Safe Roads Association. It provides for the appointment of not more than four persons by the Highway Commission, who are to act as investigators and inspectors of accidents. They are to investigate every accident in which a motor vehicle is involved and which results in the death of any person, and such other accidents as

the Commission may deem necessary. This measure, if passed, will provide the Highway Commission with the same kind of machinery for investigating accidents as is now used by the Railroad Commission. It is also provided that the license of any operator concerned in an accident which results in a death shall be at once suspended and shall be revoked unless the Highway Commission, after an investigation and a hearing, decides that the accident occurred without serious fault on the part of the operator. A license so revoked cannot be renewed within six months, and thereafter except at the discretion of the Commission. It is claimed that this bill only applies to automobilists the same provisions of law which apply to other persons engaged in pursuits which the State or municipalities consider it necessary to license.

### Suspend License for Reckless Operating.

Another proposed change in the law is that the Highway Commission shall suspend the license of any operator who is convicted in a court of operating recklessly or while under the influence of intoxicating liquor, and if the defendant appeals his case the suspension shall stand until he is acquitted, unless the Commission, after a hearing and investigation, decides to reissue the license. Other bills extend the fine and imprisonment clauses of the present law to cover the offense of running away after an accident and driving a car without register numbers in an attempt to conceal the identity of the car. The association has also presented a bill to require cars from outside States which are driven here for seven days in which they may be used without Massachusetts registration to display their home numbers substantially as required of Massachusetts cars. The association also asks for a codification of the automobile law, which has been so much changed and amended that it is now difficult to find all the pieces in the statute books.

### Worcester Wants Its Hill Climb.

Another bill that is going in is that which the Worcester Automobile Club has been trying to have passed for several years, so that it may revive its annual hill climbing contest. This bill would permit local authorities to close highways for automobile contests. Last year it was claimed that the bill was too broad, in that it would permit road races such as the Vanderbilt Cup contest. This year the club will attempt to frame the measure so that it will be acceptable.

The Massachusetts State Automobile Association has as yet taken no action regarding these bills, but it is likely that its legislative committee will attend closely at the hearings and will also be represented by counsel.

### WOULD MAKE AUTOISTS PAY FOR DAMAGE.

TRENTON, N. J., Jan. 20.—State Road Commissioner E. C. Hutchinson believes that automobiles do more damage to the roads than any other class of vehicle and would have them taxed accordingly. In his annual report to Governor Stokes the commissioner declares that the improved roads of the State have cost about \$5,000,000 and last year required the expenditure of \$592,014.75 for repairs, while the automobile revenue for this purpose amounted to only \$56,473.85. The road department has \$82,000 in automobile money for road repairs in 1908, but the commissioner feels that the amount should be increased by means of heavier license fees, so that the autoist could be made to pay for practically the entire maintenance of the State's improved roads.

### OHIO INTENDS TO PUNISH "BORROWING."

COLUMBUS, O., Jan. 19.—The act of taking another's automobile without the owner's consent is to be punished in the future as a distinct offense, if the bill introduced in the Ohio Senate this week by Sylvester Lamb, of Toledo, becomes a law. Of late there has been considerable of this work throughout the State, and in most instances when the cars are recovered repairs are much needed. Malicious destruction of property was the best charge that could be made against the offender, but now he may draw a fine of not more than \$500 or less than \$100 or one year in jail or both, so that there is little doubt that once a few convictions have been obtained under the new law, the practice of "borrowing" automobiles would run up against an effective deterrent.

## HARTFORD AUTO SHOW MET WITH PRONOUNCED FAVOR

**H**ARTFORD, CONN., Jan. 18.—Not only did the exhibitors of the show of the Hartford Automobile Dealers' Association secure a return of their entrance fees for space, but they also obtained good big hunks of dividends which exceeded all expenses. Sales were substantial, enthusiasm was created, and the event gave the local dealers a generally optimistic attitude that was plainly apparent. Foot Guard Hall isn't the most commodious kind of a structure, but it was well decorated and met the requirements fairly well. To-night the breaking up came with a rush, and before New England's Sunday had gotten under way the exhibits had been removed from the hall and little remained to tell what had taken place.

Show Committeemen R. D. Britton, F. W. Dart, S. A. Miner and E. G. Biddle received much praise for their very successful conduct of the affair. It all means that there will be another similar event next year and perhaps in a larger building.

The exhibitors were generally pleased and so expressed themselves. Louis Elmer, who had the "center of the stage" with his array of Fords, never felt better in his life. Leonard Fisk talked Corbins from early until late, apparently with success. President Britton was the Maxwell advocate, and the representatives of the Capital City Company presented the Mitchell. Sales Manager Williams enlarged upon the merits of the Atlas product, and said that results were satisfactory. Robert Ashwell presented the air-cooled Franklin; the Miner Company had a taking trio in Pierce, Knox and Buick; the Palace Company showed the Thomas, Oldsmobile and Waverley, and, of course, the Packards were in evidence, exhibited by Brown, Thompson & Company. The Electric Vehicle Company intended to exhibit, but the receivers objected at the last moment. At the Isotta Fras-

chini-Simplex stand Harry D. Miller called attention to the body and equipment designed and made by the Bridgeport Vehicle Company. Although the customers of the Hartford Rubber Works Company showed its product, the concern itself was not directly represented.

The big social event of the week was the banquet, Thursday night, of the Automobile Club of Hartford, held at the Hotel Garde. President W. F. Fuller presided at the head table, at which sat Mayor Henney, Lieutenant-Governor Lake, Water Commissioner E. L. Smith, Hiram Percy Maxim and C. H. Gillette, while the out-of-town contingent included Frederick H. Elliott, Winthrop E. Scarritt and A. G. Batchelder. Since the banquet did not start until after the closing of the show for the evening, it meant that the festivities were not concluded until well after midnight. The speechmaking included much that was complimentary, referring to the wisdom of Connecticut in having the most progressive automobile law in the entire country.

In the course of his remarks, Lieutenant-Governor Lake, who is suspected of being in line for the chief executiveship, said:

"We told the legislature," he said, "that the automobile user recognizes that every man, woman and child has rights; the automobile users of Connecticut were put on honor, so to speak, and they have made good. The trap has disappeared, and good feeling toward the automobilist is increasing. The farmer is finding out that the automobile is his friend, not his enemy, and that its advent means better roads and more pleasure for all. To automobile clubs is due largely the desirable change of feeling toward the autoist. The automobilists may well regard with gratitude the State's automobile law, and rest secure in the confidence that the time for scolding the automobile user in Connecticut is of the past.

## COMMERCIAL VEHICLE MAKERS COMPLETE AN ORGANIZATION

**C**HICAGO, Jan. 20.—The Commercial Motor Vehicle Manufacturers' Association has completed its organization, and will have its headquarters in Chicago. Its affairs are to be controlled by a board of managers consisting of the following:

H. G. Hamilton, Rapid Motor Vehicle Company, Pontiac, Mich.; Oscar Lear, Oscar Lear Automobile Company, Springfield, O.; J. E. Burke, Lambert Motor Truck Company, Anderson, Ind.; G. M. Weeks, Weeks Commercial Vehicle Company, Chicago, Ill.; H. C. Eddy, American Motor Truck

Company, Lockport, N. Y.; G. V. Rogers, Mitchell Motor Car Company, Racine, Wis.; Hayden Eames, Studebaker Automobile Company, Cleveland, O.

This board has appointed Walter Wardrop as the manager of the association, which, it is announced, "will in the future conduct all national shows, as well as public demonstrations of industrial motor vehicles."

The permanent officers of the association are as follows: President, G. M. Weeks; vice-president, Oscar Lear; treasurer, H. F. Hamilton; secretary, J. E. Burke.

### THE LATEST AUTO BILL AT ALBANY.

**ALBANY, N. Y., Jan. 21.**—Owners of motor vehicles will be interested in a new bit of legislation which seeks to direct how the rays from their lamps shall shine. The bill introduced to-day by Senator Cordts of Ulster amends the motor vehicle law and provides that "each lamp upon a motor vehicle used for the purpose of a headlight or guidelight shall be equipped with shade or other suitable appliance working automatically which shall not interfere with the full rays of the lamp projected straight ahead, but shall adequately cut off all high rising rays from said lamp." The bill was referred to the Senate committee on internal affairs. It has the appearance of being a bill to boom some special shade device for auto lamps.

### WHAT HON. ELIJAH HILL WANTS DONE.

**COLUMBUS, O., Jan. 21.**—Another automobile bill, the third in two weeks, was dropped in the legislative hopper to-day. It provides that any person operating an automobile with capacity for traveling at a greater speed than eight miles an hour shall be required to undergo an eye test to ascertain whether there be any defect in his vision that would prevent him from readily distinguishing the ordinary physical impediments and objects met with upon the public highway. The examination is to be non-technical, but practical in its purview. The bill creates a commission of vision at a salary of \$1,500 per annum, the governor to make the appointment. A fee of \$5 is charged for each certificate. The Hon. Elijah Hill of East Liverpool is author of the bill.





NEW YORK BRANCH OF THE EMPIRE AUTO TIRE CO.

### EMPIRE TIRES OPEN NEW YORK HOME.

The juncture of Broadway, Amsterdam avenue and Seventy-third street, a point that is doubtless passed by more automobiles in the course of every hour of the twenty-four than any other single spot in New York City, has been selected by the Empire Automobile Tire Company, of Trenton, N. J., as the site of their New York establishment. The store itself, a view of which is depicted herewith, faces the Seventy-second street subway station and the intervening park, which makes its location particularly prominent. This branch is in charge of Marcus Allen, as manager, and has been fitted throughout in the most modern manner.

### GASOLINE TRUCKS IN A NEW ROLE.

Evidence of the fact that the wide variety of commercial uses to which the gasoline truck may be put is daily being recognized to a greater extent is not wanting. One of the latest indications is the recent completion by the Knox Automobile Company, of Springfield, Mass., of an automobile dumping wagon to the order of the City of Cincinnati for use in collecting ashes. The appearance of this new car in the position for discharging its load is apparent in the accompanying photograph. The dumping mechanism consists of a clutch operating a slow screw which elevates the front of the body and is operated from the motor. This screw is provided with a trip at each end, which makes the operation safe and convenient. A similar device returns the body to its normal position.

This new truck is equipped with a two-cylinder, 16-20-horsepower motor and has a carrying capacity of 6,000 pounds, with a maximum speed of ten miles an hour. The body of the car is 10 feet long by 5 feet 6 inches wide and 22 inches deep. There seems to be little doubt that the successful introduction of this car will shortly lead to the use of others of similar type in other municipalities.

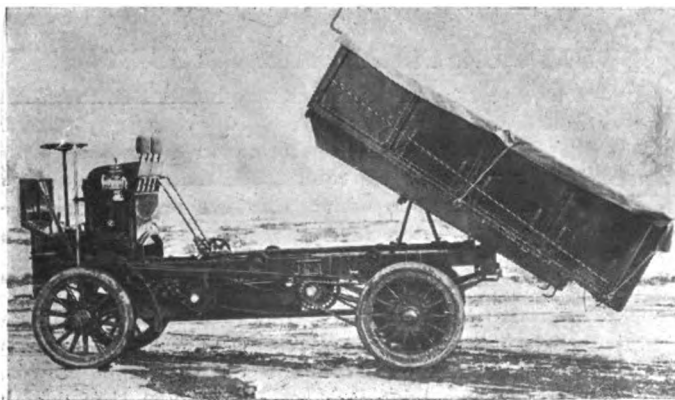

KNOX DUMPING ASH WAGON FOR THE CITY OF CINCINNATI.

### CARNIVAL AND AUTO PROCESSION FOR GOTHAM.

Automobile New York will be en fete during the week of April 6, which means, if all plans mature, that the stores of Automobile Row will be in holiday garb, that the glad hand will be out everywhere, and that the spring selling season will be ushered in with right rejoicing.

Most important of the schemes decided upon at the meeting of the New York Automobile Trade Association, held at the Hotel Cumberland, was the resolution to hold an automobile parade on the Tuesday of carnival week. There will be four main divisions in the unique procession through New York streets, the first to consist of time-honored veterans which came into the world not later than 1903; the second class will be gasoline, steam and electric cars owned by dealers, neither cars nor owners to be decorated; class three will be all types of dealers' or private owners' cars, handsomely decorated, and finally the heavy brigade in the form of commercial vehicles.

Transportation, finance and advisory committees were appointed at the meeting. The finance committee consists of Richard Newton, chairman, Dayton Motor Car Company; Frank Eveland, Stevens-Duryea, and C. P. Skinner, Mitchell Motor Company. The transportation committee has as its members E. V. Stratton, chairman, Studebaker Automobile Company, and two others to be appointed by Mr. Stratton.

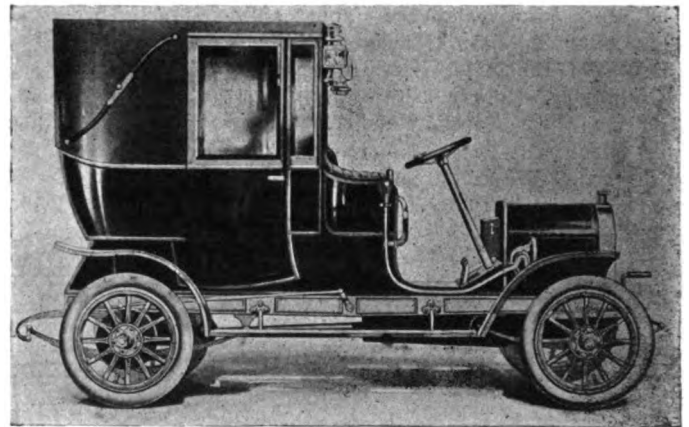

ONE OF THE NEW ATLAS TWO-CYCLE TAXICABS.

### ATLAS TWO-CYCLE CABS FOR NEW YORK.

The Atlas Motor Car Company, of Springfield, Mass., are just completing some of their new two-cycle taxicabs, several of which have been ordered by the New York Transportation Company, which is now running a number of taxicabs of foreign manufacture on New York streets. These cabs are of the two-cylinder four-cycle type, and are made in France, so that the running of the new Atlas two-cycle, two cylinder taxicabs in the same service will form an excellent opportunity for making a comparison of their advantages for this rigorous commercial use. The new Atlas taxicab is rated at 22 horsepower, and its two-cycle, two-cylinder vertical motor has exactly five moving parts, all such small accessories as the camshaft, timing gears, springs, valves and the like having been eliminated, so that its design should fit it particularly for the use of drivers whose knowledge of mechanics is extremely limited. Transmission of the power is by means of a multiple disc clutch and shaft drive, the car being capable of speeds from 3 to 30 miles an hour with the aid of the engine control alone. The frame is of arch construction and the body of aluminum. Taken all in all, the new vehicle is well designed for the purpose in view, as may be judged, at least in part, from its external appearance, as depicted in the photograph.

## BRIEF ITEMS OF NEWS AND TRADE MISCELLANY

A local baseball star has just broken into the automobile business in Philadelphia. Captain Harry Davis, the crack first baseman of the local athletics, two times champions of the American League, has opened the Columbia Garage, at Twenty-third and Columbia avenue.

Business is booming in Omaha. In two days—two days of January, when automobile sales are not supposed to be brisk—the Rambler representatives handed over eight cars to new customers. A two-cylinder Rambler was paid for and taken away on Friday, and on Saturday the record business was done, seven cars going into users hands during business hours.

On March 1 the Winton company as a corporation will begin its twelfth year. After several years of preliminary work by Mr. Winton, the company was incorporated March 1, 1897, with capital stock of \$200,000, which in 1901 was increased to \$1,000,000. The officers elected at the first meeting of the new corporation are still holding the same positions—a remarkable record considering the mutability of the industry. Winton products have ranged from single to eight-cylinder cars, and the Winton company is the only one in the world whose plant is devoted to the exclusive production of sixes.

That there is money in the taxicab business is shown by a prospectus sent out by the E. R. Thomas Motor Company of Buffalo. The figures were secured by a representative of the company who spent some time in Paris recently and show a minimum earning capacity of \$11 per car per day. On the strength of this estimate a New York concern has placed an order for fifty taxicabs that are soon to be turned out by the Thomas company, while a company will soon be formed which is negotiating for double this number. Chicago has already ordered fifty, to be greatly increased as soon as the local demand has been determined.

"I believe this year we should have the best tour ever held by the American Automobile Association," said H. S. Leyman, of the De Luxe Motor Car Company, Detroit, Mich., and a member of the tours and racing committee of the American Motor Car Manufacturers' Association. "I do not believe, however, that the rules should be changed and would suggest a price classification. Under the regulations last year, a \$1,200 car was compelled to travel as fast as a \$6,000 car, which I believe is an unfair test. A classification under the following table or something of the same order, would work to advantage and be a fairer test than the tour of 1907. Cars selling under \$1,500, 15 miles per hour; from \$1,500 to \$3,000, 17 miles per hour; over 3,000, 19 miles per hour.

Public attention during the past five or six years has been so much centered on the development of the gasoline and steam automobiles, that the advancement in the electric automobile has not been as carefully noted as it would have been had they alone been in the field. This was shown at the recent shows when some visitors at the spaces where the Babcock Electrics were on exhibition, received with some skepticism the statement that the 1908 models made by that company could travel from 85 to 100 miles, and even more, on one charge of the battery. "I thought 40

or 50 miles was the greatest distance you could travel in an electric on one charge," was the almost general expression. When told that 40 or 50 miles used to be the limit, but that now electrics could travel twice that distance, some seemed genuinely surprised.

### NEW AGENCIES ESTABLISHED.

The National Electrical Supply Company, 1330 New York avenue, Washington, D. C., is one of the latest additions to the long list of supply dealers handling the specialties of the Holley Brothers Company, Detroit, as agents.

Among the agencies recently added to the Northern Motor Car Company's long



THE RAINIER NEW YORK STORE.

It is fireproof construction throughout and can accommodate 180 cars.

list of representatives, is the Lincoln Auto Company, of Lincoln, Nebraska. This concern is one of the largest in its territory.

On February 1, the G. & T. Tire Company's agency in Philadelphia will move into their new quarters at 713 North Broad street, and will then have the largest tire establishment in the Quaker City. The building in on a corner across the street from their present location and is fully as large again as the latter.

The Cleveland branch of Morgan & Wright has been discontinued owing to arrangements which have been made with the Ohio Rubber Company, 2048 East Ninth street, for the exclusive sale of M. & W. automobile, vehicle and bicycle tires in Cleveland and vicinity.

Prescott Adamson, the Philadelphia agent for the Columbia cars, has just taken on the Renault, this being one of the numerous indications of General Manager Paul Lacroix's policy of opening branches in all the principal cities of the United States, in view of the great success that has attended the introduction of the Renault cars in the East. Mr. Adamson's

place is at the corner of Broad and Spring Garden streets.

The Mora Motor Car Company, of Newark, N. J., has just opened a New York branch at the southeast corner of Fifty-second street and Broadway in charge of W. W. Burke as manager. Mr. Burke held the same position with the Electric Vehicle Company for some time and is accordingly well known to the trade. The Mora made a name for itself in every one of the contests in which it was entered last year and it is thought that the new sizes now on exhibition will be even more successful.

The Allen-Swan Company, 1287-1291 Bedford avenue, Brooklyn, are now the agents for the Stearns cars in that city. Lew H. Allen is well-known in automobile circles at the other end of the Brooklyn Bridge, having been connected with the sales end of the Locomobile cars there for some time. He is president of the company and Halstead Swan is secretary and treasurer. A contract has also just been signed with Morgan B. Kent to represent the Stearns in the whole State of Massachusetts. Mr. Kent is a prominent Boston dealer, his place being located at 998 Boylston street. These are but two signs of the activity of Wyckoff, Church & Partridge, New York, since the consummation of the negotiations with the F. B. Stearns Company for the handling of their cars throughout the East. Agencies have also been opened in Rochester, Philadelphia and Baltimore.

### PERSONAL TRADE MENTION.

Gaston R. Rheims, for some time past manager of the C. G. V. Import Company, has just severed his relations with that firm. No definite announcement of his plans is forthcoming at the moment.

P. R. McKenny, manager of the Brush-Detroit Motor Company which handles the Brush runabout in the Michigan automobile center, has just opened up his new store at 255 Jefferson avenue, Detroit.

Alexander Winton, president of the automobile company that bears his name and designer of the new Winton "Six-Teen-Six," has just been elected the new commodore of the Lakewood Yacht Club of Cleveland.

E. R. Thompson, well known to the trade as a newspaper man, has just been appointed the New York sales manager of the Hicks Speed Indicator Company of Brooklyn. His territory includes all of Greater New York.

Robert C. Hupp, who has been with the Ford Motor Company of Detroit, for some years past in the capacity of purchasing agent, has resigned to accept a position as factory manager with the Regal Motor Car Company. Mr. Hupp has been associated with the automobile business since its inception and is familiar with every branch of it.

Thomas D. Hanauer, for some time with the Smith & Mabley Manufacturing Company, when the latter firm was building the Simplex cars, and one of the charter members of the Society of Automobile Engineers, has just accepted a position as head instructor with the New York School of Automobile Engineers, 146 West Fifty-sixth street, New York City.

### INFORMATION FOR AUTO USERS

**Watts-Detroit Carbureter.**—F. J. Watts is the designer of this new carbureter, and it is the result of considerable study of the problem of carburetion, as Mr. Watt has been connected with the automobile industry for several years, be-

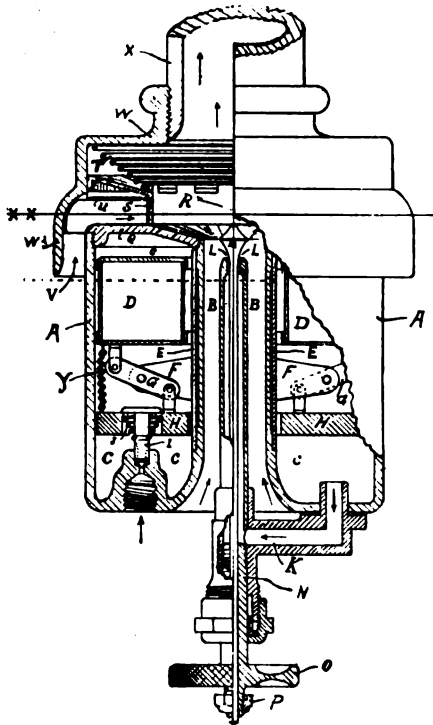

PART SECTIONAL VIEW WATTS CARBURETER.

ing best known to the trade as the vice-president of the R. E. Hardy Company, New York, and the inventor of their "Sta-Rite" plug. One of Mr. Watts' chief aims in bringing out this new carbureter has been to overcome the annoyance caused by the more or less constant variation of the fuel level, due to jar and bouncing of the machine over rough roads. The Watts-Detroit carbureter represents an equally radical departure from current standards as did the Sta-Rite plug when first introduced. In the

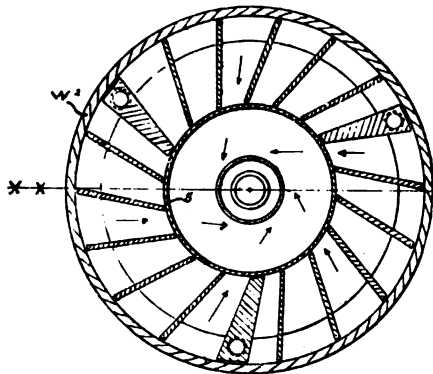

PLAN VIEW OF COUNTERBALANCING DISK.

accompanying illustrations a sectional view and a plan view of the device are given. The part marked HH is a flat disk which is designed to exactly counterbalance the float DD, and also to act as a dash-pot to prevent chattering of the supply valve. This construction makes it impossible for any outside disturbance to affect the position of the

float, which is kept in a submerged position by means of two light springs of ample length. The initial air supply is drawn through the annular passage BB, and additional air comes through the large annular passage V, being passed through the latter and admitted in quantities to suit the requirements and speed of the motor, under the circular edge of the large auxiliary valve S. The opening of the latter varies according to the speed of the motor and the position of the throttle. The mixture is produced in a distinctly novel manner by rapid rotation of the contents of the mixing chamber, this movement being produced by a peculiar arrangement of fixed guides which confine the air within gradually narrowing channels, so that its speed is easily accelerated to the rate naturally due to the amount of suction, which can be remarkably light due to the unobstructed nature of its passage and the peculiar rotating effect. A suction of but one pound per square inch normally produces a flow at the rate of 332 feet per second, which is fast enough to rotate the contents of the mixing chamber at the rate of 500 revolutions per second. It is being manufactured and marketed by the Watts-Detroit Carbureter Company, 58 Griswold street, Detroit, Mich.

**Stickney Safety Steam Generator.**—This generator was designed by a well-known builder of light marine engines and fast launches and is now being marketed



THE STICKNEY STEAM GENERATOR.

by the Portland Garage Company, A. G. Frost, manager, of Portland, Me. It is said to give as high an efficiency and as dry steam as the flash boiler when working at its best, but is impossible to over superheat, and it also has the necessary reserve to climb any hill without recourse to the hand pump. It has the advantage over the fire tube type of producing superheated steam, and is not liable to injury by burning on account of lack of water. The central drum is of heavy plate, the heads being flanged and riveted, all material and work conforming to the United States Government standards. Surrounding the central drum and leading from its top is a down-flow superheating coil connecting with the engine. Three sizes are built, for runabouts, surries and small touring cars. The same concern also markets a patented

automobile turntable of strong and simple construction for garage use, besides several other steam specialties designed to improve earlier models of well-known steamers, which they make a specialty of refitting and birnring up to date.

**Hoyt Testing Voltammeters.**—Increasing knowledge of the necessity of watching the adjustment of coil vibrators and the state of the batteries on the modern car, if efficient ignition service is to be obtained, has created no little demand for special testing instruments for this purpose. As yet most of these are of the portable type, but owing to the frequency with which they are employed it seems fitting that they should form a part of the permanent equipment of the car. The Hoyt Electrical Instrument Works, Penacook, N. H., are now placing a special instrument of this kind on the market. As shown by the perspec-

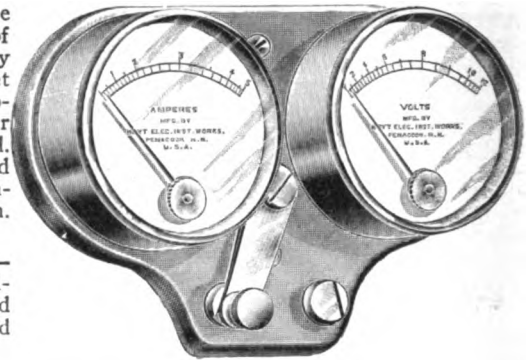

HOYT VOLTAMMETER, TO MOUNT ON DASH.

tive illustration, there is an independent instrument for voltmeter and ammeter, for reasons that will appear, and the whole is adapted to be mounted on the dashboard. Its relation to the remainder of the ignition circuits is shown by a diagram illustrating the wiring necessary and which is supplied free by the makers. The two instruments are so interconnected on their supporting panel that the ammeter shows the actual amount of current being consumed by each coil, while the voltmeter indicates the voltage of the cells when supplying current; that is, under actual working conditions, which is the only way they should be tested. The small switch shown between the two instruments gives two points of control in addition to the neutral point, which is the extreme left. With the switch lever between the two, the ammeter alone is in circuit, while at the extreme right both instruments are connected with the ignition system of the car.

**Triumph Grease.**—After devoting considerable study to the requirements of automobile lubrication, the Perfection Grease Company, South Bend, Ind., have brought out a new grease under this title, for which many advantages are claimed. The new Triumph grease is spongy when made and remains in that form, it does not melt or run out of the bearings, nor does it get stiff so that it will not do its duty properly, no matter how cold the weather happens to be at the time. It is red grease, and, according to the makers, it is always red, and its unchanging character makes it a profitable investment, as it "stays on the job" and does not distribute grease spots all over the car.

# THE AUTOMOBILE

## Taxicabs Unaffected by Weather Condition

by W. F. Bradley

THE psychologist is better fitted than the mere automobile observer to explain why the teamster is most effusive when he is doing the least amount of effective work. When New York woke up last week to find that a vigorous baby blizzard had come in from the northwest during the night and taken possession of the city, it was the teamster body that chuckled most heartily, metaphorically patted itself on the back and went forth to plunge through a foot of snow, add confusion to confusion, but remain happy as a sand lark through it all.

Adverse weather conditions, whether from frost or snow, not only disorganize the horse traffic of the city, but are the direct cause of the horse traffic disorganizing every other means of surface transportation. Electric trolley cars soon had their right of way cleared for them by means of powerful plows and revolving brushes; automobiles fitted chains



and were able to run about any part of the city after the first snowstorm of the year with practically no diminution of their speed; but the horse was unequal to the occasion; it floundered in the snow; it slipped and skidded and fell where snow had given place to a glassy surface; it was mobilized for the removal of the snow, but was so unequal to the task that

often when a white load had been shipped the patient animals collapsed, or were unable to get under way without extraneous help. Meanwhile passengers in surface cars and cabs fumed as they were held up in blocked traffic for any time from five to twenty minutes, and cursed the snow which was the cause of the delay. The minority who found themselves encased in a double team crosstown horse car, which the city maintains as an exhibition of how we used to travel, put the blame where it properly belonged, but very few thought of charging the horse with traffic disorganization.



THOMAS TAXICAB DEMONSTRATING IN SNOWBOUND COLUMBUS CIRCLE IN COMPANY WITH A LARGE AUTOMOBILE FAMILY.



Yet the fact remains that New York, in common with hundreds of other cities, loses time and money through the inability of the horse to perform its accustomed duties whenever a snowstorm of any severity descends. The point to be noted is that not only the horse owners and users suffer inconvenience and loss, but that others, who would not otherwise be affected, have to bear the burden of the breakdowns. If conditions were reversed, and the newly arrived automobile obstructed traffic whenever weather conditions were unfavorable, the necessity for a more reliable service would be immediately grasped. Centuries of habit, however,

tires had received some temporary bandage. Private automobiles found half the usual width of roadway rather narrow quarters in which to turn round, and long wheelbase cars needed to be skilfully handled in crowded crosstown streets; but they never refused to do their work.

The absurdity of the law against chains in certain sections of the city was never more forcibly apparent than during the period of the snowstorm. A few car owners, knowing that the police would be little in evidence in a snowbound park, ventured on forbidden ground, with wheels well equipped with chains and other devices of a similar nature, and had the satisfaction of proving that a considerable depth of snow is needed to stop a modern car. Flying through drifts at thirty-five miles an hour is an exhilarating experience.

#### Taxicabs Quick and Reliable When Conditions Are Bad.

But it was the taxicab which shone out most brilliantly when city traffic was in a state of anarchy, the little gasoline vehicles making light of a road surface that held up all horse vehicles, and working a route between piled up banks of snow, through which heavy teams and surface cars struggled for right of way, in a manner that was a revelation to traffic inspectors. First experience with wintry weather showed that there would never be any delay if all means of transportation were as reliable as the taxicab.

Though the diminutive power plants under the diminutive bonnets were only designed for economical use under normal city conditions, they met the strain put upon them in excellent style, not a single cab being stalled about the town or on the steep, snowy grades of Washington Heights, to which many a user directed them, with a certainty of being able to reach home quicker by this method than by any other.

Rather more gasoline than usual must have been consumed, for it was sometimes necessary to slip into the intermediate or drop down to the low gear on the snowclad grades. One passenger has a story of how a short ride would have cost him dear if he had not departed in fright at the rapid rate the figures were adding up a total on the tell-tale indicator. The vehicle, which was without chains, was engaged for a run of about a dozen blocks. Before a dozen yards had been covered the cab was blocked in deep snow, the driver raced his motor, the wheels flew round, a shower of ten cents appeared in rapid succession on the indicator, and the vehicle stood still. Then the fare bolted rather than face that grand total. Though the case is an exceptional one, and would not have occurred if the wheels had been equipped with chains, it is worth asking, in view of the fact that some cities to which the cabs will be introduced have much more snow than New York, if the indicator should not always be driven from the front wheels, instead of the rear.

#### Drivers Found Business Brisk During Storm.

Taxicab business was particularly brisk during the height of the storm, every cab being snapped up as it entered its stand, and some would-be traveler always being in waiting for the arrival of a vehicle. One driver cooling his heels outside a private residence while his clockwork mechanism rolled up ten cents at regular intervals of six minutes declared enthusiastically:

"Gee, I guess we are doing business this weather! Why, I haven't had time to get a bite of lunch yet—it was then two o'clock—and the longest I have loafed this morning has been three minutes. You see," he added confidentially, "we are the only people who can get around with the streets in this condition, and everybody wants us.

"You bet that little engine can get through it all right. I was downtown yesterday in the early morning, when the snow was up to the axles, but she never stuck. I guess them leather bands can pull you through anywhere. They are

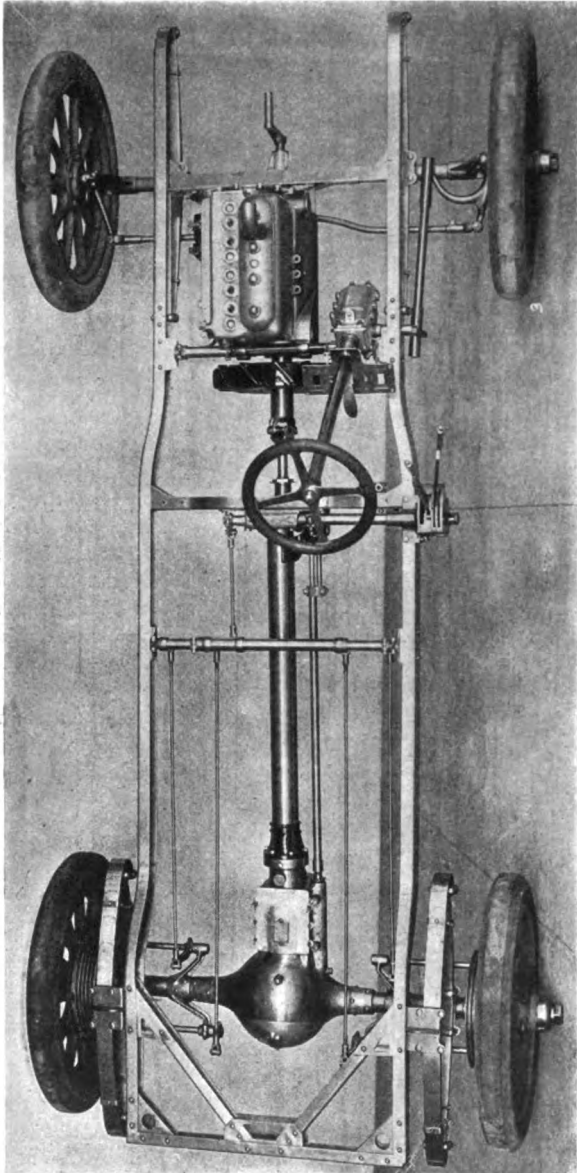

CHASSIS OF THE FOUR-CYLINDER THOMAS TAXICAB.

blind one's eyes to obvious defects. Instead of the conclusion that horse traffic is no longer adequate for modern city conditions, the oldest form of locomotion is quietly accepted as the inevitable.

In the earlier hours of the morning, before removal gangs had thoroughly warmed up to their task, some of the Fifth Avenue gasoline buses had trouble getting round corners where snow was particularly deep. But their inability to perform their task as regularly as usual was entirely due to neglect to fit chains or some other anti-skid device to the smooth, solid tires. Heavy three and five ton trucks, with full loads aboard, rumbled along as usual when their solid

giving us a gallon of gasoline free every Monday morning, so that we shall have no excuse for freezing up. It isn't much if the weather is really cold, and you have to keep the engine turning over, but it is better than nothing."

Thomas chose the height of the snowstorm for demonstrating to Father Knickerbocker the new taxicab which he has designed at the Buffalo factory. E. C. Morse, manager of the E. R. Thomas Company, arrived with one cab, and during the stormy period of Friday and Saturday was skimming over the city with the heads of transportation companies interested in the latest form of rapid transit. It would have been impossible to have selected more strenuous conditions or a set of roads which more thoroughly tried the ability of the little town car, yet it responded in a thoroughly satisfactory manner. Manager Morse declares that he is negotiating with a number of large firms and fully expects to see a big series of Thomas taxicabs on the streets of New York within a few months. The first batch has just been sent to Chicago and has already been put into circulation. The interesting feature of the Thomas cab is that it is the first specially designed American-built taxicab.

103 inches, which, together with a very wide steering angle, makes it possible to turn round in a very restricted space.

#### How Patrons of One Hotel Insist on Taxicabs.

It has not required a very long acquaintance with taximeter cabs to prove to the public in what direction they can obtain the best and quickest transportation service, as is shown by an incident at the Waldorf Astoria. The patrons of that elegant hostelry are supplied with a horse cab service, furnished by an outside liveryman, but may have taxicabs by requesting the management to telephone to the company's headquarters for one. So many persons showed a preference for the mechanical form of transportation, with a clock to announce the amount of fare due, that the manager of the hotel was at last obliged to inform his liveryman that gasoline taxicabs must be installed instead of horse vehicles.

At the office of the assistant manager of the Waldorf Astoria, ignorance was professed of the entire story, but the information given that the hotel was always willing to send for a taxicab when visitors preferred this mode of

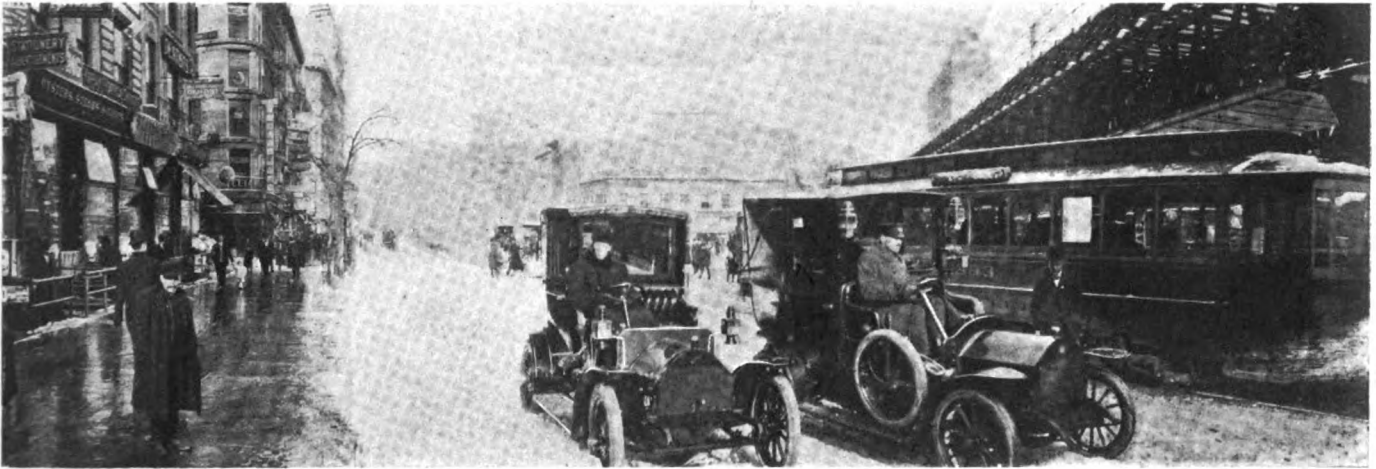

UPPER BROADWAY REMAINED SNOWBOUND FOR SOME TIME, BUT AUTOMOBILE SERVICE NEVER SUFFERED.

which is being turned out in any quantities. "Deliveries can be made," said Mr. Morse, "in less than six weeks for moderate quantities, and larger quantities in two months. We have made arrangements at our factory for a large output and have a capacity of two thousand machines from now to the end of September."

Externally, the Thomas taxicab differs from those in use in this city by being finished in artistic but sober colors, giving the vehicle more the appearance of a private carriage than a public conveyance. In general lines it closely follows European standards, having been designed by an engineer closely connected with French practice. One of its most noticeable features is a four-cylinder engine in a single casting, the inlet and exhaust manifold and the water outlet manifold being cast integral with the four cylinders. Dimensions of the cylinders are 3 3-8 inches by 4 5-16 inches bore and stroke, giving a rating of 16-22 horsepower. The crankcase, water intake manifold, water-jacketed carburetor and gear cases form one manganese bronze casting, the entire power plant thus being composed of two castings only. An innovation is the absence of a center crankshaft bearing, the two end bearings, however, being of specially liberal dimensions. Ignition is by means of high-tension magneto, and water circulation is by thermo-siphon, with a honeycomb radiator set exactly over the front axle.

With a view to extreme simplicity, the transmission has been encased in the rear axle, the car thus consisting, in reality, of a simplified engine at one end and a rear axle and transmission at the other. Wheelbase of the cab is

locomotion to the vehicles at the door. A notice to this effect indeed appears in the main hall. At the William H. Seach livery stables, from which the Waldorf cabs are supplied, everybody desired to be mute on the passing of the horse. As those particularly interested in the change have been spending considerable time recently in demonstrating taxicabs, the indications are that the story, if not correct in every detail, is at least right in its essentials.

#### BOSTON SOON TO HAVE TAXICABS.

BOSTON, Jan. 27.—A taxicab service is among the probabilities of the near future in this city and already there is one experimental cab on the streets, while a company has been organized to introduce a service here similar to the one in New York. The Boston Taxicab Company, which was incorporated recently in Massachusetts, is behind the plan, and it is understood that this company is a subsidiary of the New York Taxicab Company, which operates a large number of four-cylinder Darracq cabs in that city.

#### NOW AUTOCABS FOR QUAKERTOWN.

PHILADELPHIA, Jan. 27.—Secretary-Treasurer L. T. Layton, of the Philadelphia Taxicab Company, is authority for the statement that his concern will be ready within a month to inaugurate its business here with at least fifty vehicles.

The local company, which is capitalized at \$200,000, is composed of men prominent in the affairs of the city.



NINTH ANNUAL BANQUET OF THE AUTOMOBILE CLUB OF AMERICA, HELD JANUARY 25, IN ASSEMBLY HALL OF NEW CLUB HOUSE, FIFTY-FOURTH STREET, NEW YORK CITY.

## A.C.A. BANQUET A GATHERING OF THE OLD GUARD

THE ninth annual banquet of the Automobile Club of America, held Saturday evening, January 25, in the palatial home of the pioneer autoing club of America, was remarkable for a goodly representation of the old guard of automobiling. As the A. C. A. was the first club formed in this country, it secured a membership which embraced not a few from other cities, and while many of these have become directors of local clubs, they elect to continue their membership in the big metropolitan organization. Since it was a gathering in vast degree of the early advocates of the motor-driven vehicle, it was not amiss that M. Jusserand, the French ambassador to this country, should be the guest of honor, it being a recognition of the debt which this and other countries owe to France for being greatly responsible for the coming of the automobile. While the pupil now considers that he is capable of instructing as well as the master, it is only fair to remember that the first chapters were learned from the lessons and experiments of the French makers, who, in the past, have certainly accomplished much to blaze the way for automobiling's progress.

President Colgate Hoyt, who presided at the head table with his accustomed dexterity, complimented the club members upon the condition of their organization. The new home on West Fifty-fourth street possesses ample garage accommodations and boasts of a dynamometer superior to any other ever installed. Commented the president:

"The property in which we are now housed will have cost not far from \$800,000. This money has been furnished as follows: By the club, \$170,000; by a first mortgage at 4-1-2 per cent. interest, \$350,000, which was secured, by the way, through the efforts of our treasurer, Mr. Fanshawe, without any commission being charged to the club; by a second 4 per cent. mortgage, furnished by the members at par, \$300,000; and although we have only been occupying this present house for eight months, through the wise handling of finances we have been able to draw from the bonds held by the members and pay off and cancel same, at par and interest, to the amount of \$40,000, leaving the total mortgage obligations of the club now \$610,000, against \$650,000 when we moved in."

Warmly welcomed was the French ambassador when he arose. In the course of his speech he said:

"One of the earliest dreams of mankind has been one of the last to be realized, and it has been realized only now under our very eyes—the conquest of space, the abolition of distance. To be able to flash your thought across continents and oceans is admirable; to have your voice carried through wires, and now without wires, is a wonder. But nothing can ever equal real presence, the actual transportation of your own person—thoughts, words, body and all—where you want to be. This the men before us could do only in their imagination. The Orientals had King Solomon's carpet, Ruggiero had his hippogriff, Rabelais had his movable roads, we have our automobiles, and we equal them all.

"When I think of the change this invention, while it is yet in its infancy, has worked in the world, I am proud to think that it is a French one. France is the mother of many men and many things. The genius of the race shows, luckily, no trace of age or of fatigue. It has never been more fruitful, having of late years given to the world the first dirigible balloons, the first submarine boats, that extraordinary metal, radium, and all that the discoveries of Pasteur mean for the alleviation of the sufferings of men. It has cut the Suez Canal; it has begun the Panama one.

"One of her sons, Dr. Laveran, has just received the Nobel prize for his discovery of the noxious action of mosquitoes in the spreading of fevers. And it has given the world the automobile."

Senator Chauncey M. Depew responded to the toast, "America, the User of the Automobile." His remarks included an excellent dissertation upon good roads, and he showed by statistics the increase in automobiling.

Augustus Thomas, the playwright, with "The Automobile and the Pedestrian" as his subject, supplied a budget of excellent humor, which was duplicated and even excelled by the scintillations of the Hon. Job E. Hedges, whose subject was simply announced as "Automobiles." Persistent calls

for Patrick Francis Murphy, one of the most accomplished after-dinner speakers, finally took him to the speaker's rostrum, from whence he proceeded to turn the tables on President Hoyt for having disregarded his promise not to call upon him for any remarks.

At the guest table, besides the orators of the occasion, were Dave Hennen Morris, during whose presidency the clubhouse project was successfully set in motion; Albert R. Shattuck, another ex-president, always active if not entirely effective in his methods; Dr. Schuyler Skaats Wheeler, the man responsible for the dynamometer; Col. John Jacob Astor, a persistent buyer of automobiles; the Hon. Jotham B. Allds, the New York senator who is shortly going to have something admirable to propose in the way of directing the good roads work in this State; Oliver A. Quayle, the indefatigable president of the New York State Automobile Association; Charles J. Edwards, the newly elected president of the Long Island Automobile Club; Gen. George Moore Smith, chairman of the club's show committee; Rev. Wilton Merle Smith, the club's chaplain, and Henry Sanderson, director of the club's garage department.

Scattered about the room were men who have been prominent in automobiling since its inception. At one table sat Alfred C. Bostwick, one of the early "daredevils" of the sport; not far away was the industrious Walter Christie, holder of the world's one-mile track record. A. L. Riker, winner of the first road race held in this country, was another ex-racing notable; Percy Owen, once a member of the American Gordon-Bennett team, was also present. Jefferson deMont Thompson, chairman of the A. A. A. Racing Board and Vanderbilt Cup Commission; A. R. Pardington, who once filled the same dual rôle, and Frank G. Webb, the vice-chairman of the 1908 Racing Board, were gathered at one table. Another in evidence was Robert Lee Morrell, also A. A. A. ex-chairman of Racing Board and Cup Commission.

Cortland Field Bishop, president of the Aero Club of America; Alan R. Hawley, and Augustus A. Post composed a prominent sky-pilot trio. Milo M. Belding, Jr., former chief counsel of the New York division of the L. A. W., and C. J. Obermeyer, once president of the L. A. W., were two cyclists who linked the past with the present.

Windsor T. White, S. T. Davis, Jr., S. D. Waldon, E. T. Birdsall and A. H. Whiting were observed in the old guard track contingent, which also included W. D. Gash, E. B. Gallaher, Frank Eveland, Walter C. White, Peter Fogarty, Gaston Plantiff, C. R. Mabley, R. A. Greene, Charles E. Miller, C. R. Teaboldt, J. F. Plummer, E. R. Hollander, A. J. Picard, E. R. Partridge and H. R. Lounsbury, Jr.

Then there were Albert N. Chandler, president of the Automobile Club of Philadelphia; Frederick H. Elliott, secretary of the A. A. A., Gage E. Tarbell, of life insurance fame; Col. L. C. Weir; Capt. Homer E. Hedge, who was one of the first movers in the organization of the A. C. A., as well as the Aero Club; William Pierson Hamilton, active in the club's show promoting; Robert Graves, owner of racing cars; H. M. Swetland; L. R. Smith; J. Dunbar Wright, the globe-traveler; Waldron Williams; T. Francis Moore, Briarcliff racing secretary; Louis and Andre Bustanoby; Orrel A. Parker; Charles H. Hyde; W. W. Niles; R. C. Newton; Lowell M. Palmer, Jr., and Arthur J. Moulton.

Two of the notable absentees were Winthrop E. Scarrit and George F. Chamberlain, both of whom have done much to aid in the progress of automobiling and who have also been especially active in A. C. A. matters. The metropolitan and trade press was well represented.



## THROUGH KENTUCKY, DOWN INTO TENNESSEE

By PATHFINDER.

IN continuation of our tour of exploration, told of in the January 23 issue of *THE AUTOMOBILE*, we have covered a trifle over 500 miles since leaving Columbus, O. Two-thirds of this mileage has been in Kentucky—a State which offers as much of interest to the tourist as any in which I have ever traveled.

Leaving Columbus we continued due west, and followed the National Highway to Springfield. This stretch of 45 miles offers unusual opportunities for speeding. Straight as an arrow, for the most part perfectly level, free from ruts, and not passing through any towns of size, the distance can readily be covered in an hour and a half, provided, of course, that there are any tourists who ever exceed the legal limit of 20 miles per hour. Three miles west of Springfield we turned off the National Highway, not with-

State, I should say here, we were favored by clear weather, although we felt the effects of the cold wave which has swept the northern States.

The first 25 miles out of Covington is over a toll road, and we paid a total of 81 cents on this stretch. We did not have to pay toll again in the State, although we saw thereafter many abandoned toll gates testifying to the fact that, until recently, toll was collected on most of the pikes. After leaving the toll road we reached a stretch where the road parallels the Queen & Crescent Railroad, and in 35 miles we took note of 28 railroad crossings, all over the same line. The turns across the track were often very abrupt, as were the turns over the bridges which span the tracks, and we found that great caution was necessary in approaching these crossings. The road from about 50 miles to 70 miles out of Covington leads through a hilly and rather lonesome country. The turns in the road are numerous and of extreme sharpness, and the same care was necessary as in the section above alluded to.

### Horses and Mules Numerous.

As we neared Georgetown the road straightened out and widened out, but here a difficulty presented itself, which, in greater or less degree, has been with us ever since—namely, the trouble in passing horses and mules. It happened that County Court was being held that day in Georgetown, and this occasion is, by local custom, a time for general horse trading. Every one in the county who raises horses or mules—which is almost equivalent to saying the entire population—had come into town to buy or to sell. We met numerous combinations, such as the following: A man driving a team with



THIS LOOKS VERY MUCH LIKE A REAL OLD HOME IN KENTUCKY AND THAT'S WHERE IT IS.

out a feeling of regret, as we had traveled on this one road for about 320 miles. What a change was noticeable as soon as we turned off the Highway! Instead of a wide, straight highway, with few, if any turns, we had a narrow little lane, winding back and forth across the railroad. The surface was good, however, and we soon reached Dayton, 71 miles from Columbus. Here we looked into our water tank and saw that we had used but a gallon of water on the 71 miles—a striking demonstration of the efficiency of the condensing system in the White steamer of to-day.

From Dayton a fair pike leads to Cincinnati by way of Miamisburg, Bethany and Reading. There is little chance that one will go in the wrong direction in this vicinity. While still 20 miles from Cincinnati, we saw before us the cloud of soft coal smoke which hangs over the city, and by the time we reached our hotel we were covered with soot. Our odometer showed 125 miles for the trip from Columbus.

None of us had ever been in Kentucky, and we started out eagerly the next morning and crossed the toll bridge, which carried us over the Ohio river into Covington. From this town we had a gradual three-mile climb on a wide, slippery road, which, like much of the Kentucky roads, I fear would be rather bad in wet weather. While we were in the

one hand and with the other holding the halters of two or three newly purchased horses, which traveled behind his buggy. The horses were for the most part young and untrained, and the trouble in passing them may be imagined. We gave every assistance possible and most of the horsemen accepted the situation as a matter of course. There were one or two, however, who made sundry remarks regarding what they would do if they "had their gun." For traveling in Kentucky, sir, you will find it an advantage if your engine can be stopped when desired and easily restarted, and the more quietly you can start the more serene will be your progress.

There is a fine road from Georgetown to Lexington, and at the latter place, 88 miles from Cincinnati, we spent the night. Lexington is the center of the horse-raising section of the State. Good roads radiate from the city in every direction, connecting it with the great stock farms. The main street, just beyond the built-up section of the town, has been widened into a great speedway, where famous trotting horses are even more common than racing cars at Ormond and Briarcliff. Lexington was the home of Henry Clay, and we visited his old homestead outside of the city, as well as his monument in the cemetery.

Leaving Lexington, we had a splendid macadam road to Frankfort, 26 miles away, the capital of the State. Here we saw much of interest: the monument to Daniel Boone, the old State arsenal, the Capitol Hotel, where Goebel died, and the century-old State House, which impressed us even more than the magnificent new State House now nearing completion.

#### Bryan Orthodox on Roads Question.

It chanced that William J. Bryan, of Lincoln, Neb., was in Frankfort when we passed through. We talked with the famous orator and sounded him as to where he stands on the good roads question. We found that on this topic his views are entirely orthodox.

We had a very uneventful trip from Frankfort into Louisville, 80 miles from Lexington. This section of the State was settled very early, and we saw some fine examples of real colonial architecture. The last 15 miles into Louisville was over a fine, straight, perfect macadam road. We were very favorably impressed with Louisville, particularly with the wide well paved streets and the fine Hotel Seelbach. In the morning we drove through Cherokee Park and other parts of the city, so that it was noon before we headed southward.

The road was reasonably good for 40 miles, as far as Bardstown, one of the oldest settlements in Kentucky. I might say here that it was not until we had traveled more than 100 miles from Bardstown that we again saw a community that was anything more than a cross-roads hamlet. Beyond Bardstown, the country became wilder and the road gradually grew poorer. At Buffalo, 69 miles from Louisville, began a long stretch of very bad going. There was sand, mud, rock, water; in fact, everything except a smooth hard road. Eighty-five miles out from Louisville we crossed an iron bridge about 100 feet long, for which 40 cents toll was exacted.

We had realized all day that we would have to "rough it" that night and our expectations proved correct. We put up at a cross-roads, called Canmer, in a "hotel" which had three rooms for guests. We were served with sausages and raspberry jam for dinner and the same menu for breakfast. Our host sat down at the table with us, with his hat on, and asked us innumerable questions about ourselves. Incidentally, we obtained considerable information from him, including the fact that our road passed within 12 miles of the Mammoth Cave. We determined to take in this great natural curiosity, ranked as one of the "seven wonders of the world."

#### A Visit to the Famous Mammoth Cave.

The next morning, after 18 miles of bad going on the main north and south route, we came to Cave City. Here we left the main road and traveled over 12 miles of as bad road as I ever saw when we reached the cave. If it were not that we were told that the road is fairly good in summer, I could not conscientiously recommend this detour to any one. We were 3 1-2 hours in traveling the 30 miles between Canmer and the cave. Here we spent all told about three hours. The guide book says that there are 152 miles of avenues and grottoes in the cave. Visitors come from all over the world and spend days and weeks in exploring the place. As for our party, we all preferred traveling on the pikes, and we were satisfied to walk in for a mile or so and then turn around and walk right out again.

Then came 11 miles more of miserable road before we regained the main road at Glasgow Junction. From here we had an easy 24-mile drive to Bowling Green, where we spent the night. In this town the Confederate forces went through the formalities of installing a State government in the first year of the war, the members of which were promptly driven out by the Union sympathizers from other parts of the State.

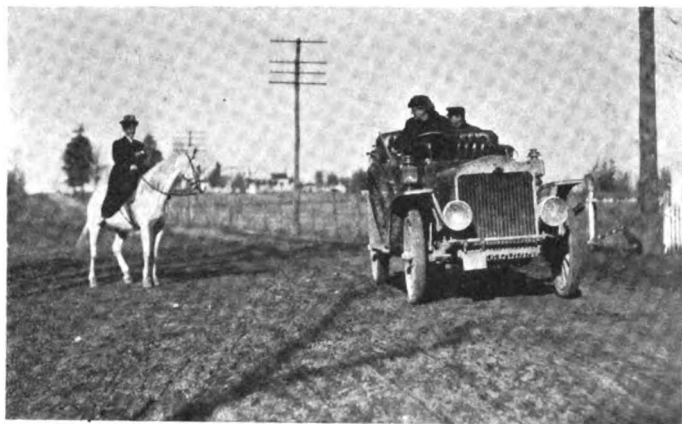

ACQUAINTING HORSE AND AUTO—AND ALSO OTHERS.



IN THE CENTER OF THE HUSTLING VILLAGE.

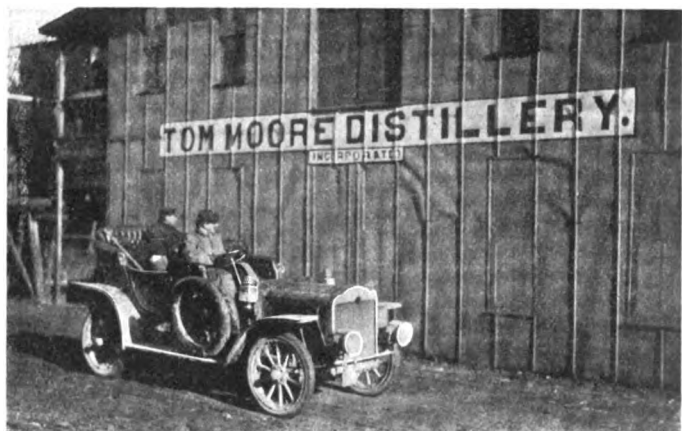

"WHAT'S IN A NAME?"—WILLIAM SHAKESPEARE.



THE ROAD BETWEEN CAVE CITY AND MAMMOTH CAVE.



HENRY CLAY HOMESTEAD NEAR LEXINGTON.



LOOKE MONUMENT AT FRANKFORT.



ONE OF THE TYPICAL SOUTHERN MANSIONS.

From Bowling Green there is a direct and unmistakable pike right through to Nashville. Thirty miles from Bowling Green we crossed the line into Tennessee and left Kentucky behind us. Kentucky is a fine State; if poverty has any place there, it did not lurk near the roads where we traveled. Everywhere the land shows evidence of great fertility and the crops of tobacco and grain bring profitable prices. The houses in the country are substantial and comfortable, and there seems to be a fine saddle horse for every member of every family. Kentucky has many miles of fine road, and there has been no more gratifying feature of my trip than to see the evidences of projected road improvement work in almost every part of the State.

So far we have seen very little of the State of Tennessee—less than 40 miles. But as soon as we crossed the State line from Kentucky we noted a difference in conditions. The fields were not so carefully cultivated, there were broken-down rail fences instead of wire fences, and there were no bridges over the small streams. However, we had 15 miles of fine macadam into Nashville, and I will “suspend judgment” on Tennessee for the present.

A touring party, following the route which I have outlined above, would probably find it best to observe about this schedule: First day, Columbus to Cincinnati; second day, Cincinnati to Lexington; third day, Lexington to Louisville; fourth day (if early start is made), Louisville to Mammoth Cave; fifth day, Mammoth Cave to Nashville. While we spent two nights on the road between Louisville and Nashville, we had but a half day's traveling on the first day and the same amount on the third day. It is a reasonable assumption that the roads will be in better condition in the touring season than they are at present.

This is no country, however, for fragile machines or inexperienced drivers. There are no garages every five or ten miles as there are in New York and New England, and the touring party must be absolutely independent of outside aid. Finally, this is not a country for the scorchers—the roads are too rough for speed, and furthermore, the tourist must be prepared to stop his car and engine to allow horses and mules to pass by. To the trained tourist, who is looking for novelty, who is satisfied to cover an average of from 90 to 100 miles a day, who is considerate of the rights of other users of the highway, Kentucky extends the hand of welcome.

#### FOREIGN CARS COMING FOR NEW YORK-PARIS.

Foreign contestants have already commenced a journey which will not end, if all expectations are realized, until the automobile has put a girdle round the globe. Cable announcement from Paris is to the effect that the Brixia-Zust, one of the Italian contestants, has reached the French capital under its own power and will be shipped for New York next Saturday on the *Lorraine*. On its journey it was joined by the Motobloc, built at Bordeaux, and ran with that machine until the city boulevards were reached. Crowds in the streets became so dense that traffic was disorganized and the police were obliged to order the two automobiles to quit the stand they had taken opposite the *Matin* office.

There will be three cars on the *Lorraine*, due to arrive at New York on February 8, the number being made up of the Brixia-Zust, from Italy; a De Dion, and a Motobloc, from France. The only German participant, the Protos, will arrive one day later on the *Kaiserin Auguste Victoria*, having been shipped direct from Hamburg.



THE NEW STATE HOUSE AT FRANKFORT, KY.



CANDIDATE W. J. BRYAN AND PATH-FINDER JOHNSTON.

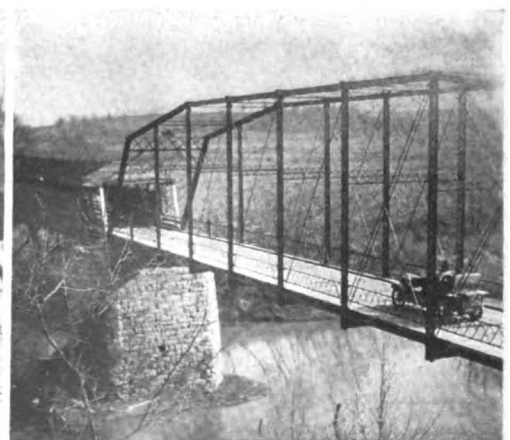

A BRIDGE COMBINING NEW AND OLD TYPES.

## SOME POINTERS FOR THE TROUBLE HUNTER

By CHARLES B. HAYWARD.

IN one or two instances, so-called authorities on the subject have been at pains to prepare a list of all the principal ailments that can afflict the automobile in one form or another. Seldom, if ever, has the compiler made any attempt to include *all* the things that can possibly happen to a car, and in view of the extreme rarity of many forms of ailments, the futility of even attempting to complete such a compilation must be manifest. Hence, only the principal defections of more or less common occurrence are usually included in such lists, though the impression made by their length is more than sufficient to suggest that a fine-tooth comb had been conscientiously employed in the process and that many an unknown disease has been brought to light for no other purpose than to show that it exists, and incidentally to swell the list. The feelings of the new owner of a car when he has an opportunity, for the first time, to survey such a list, are akin to those of the layman upon getting his initial glance at the interior of a medical work which gives him a faint idea of the truly wonderful variety of diseases that humanity is heir to. Whether gazing over a list of automobile ailments is apt to inspire thoughts of a nature akin to those of the average man who sees a remarkable coincidence between the symptoms described and his own, in almost every case, and thus make of the autoist a hypochondriac by proxy, is a question the answer to which inclines toward the latter view, for when hunting trouble that baffles discovery few clues are too slight to be followed and a long list is a most prolific source of inspiration.

If the beginner will observe the experienced trouble hunter round an automobile—particularly those who have achieved a reputation as wizards of their craft, he will not be forcibly impressed with any apparent following out of a well-defined system of searching for the cause of the ailment. On the contrary, it will appear as if the searcher jumped aimlessly from one thing to another, and frequently had scant idea of what to tackle next after his preliminary ministrations had failed of their anticipated effect. Of course, it is mighty disappointing when you have fully made up your mind that the carbureter is at fault and its malady is of a certain well-defined nature, such as a plugged-up jet, or a leaky float, for instance, to find that no such thing exists. "Well, then, it must be the ignition" may be the conclusion, and when a thorough examination reveals nothing wrong there, the amateur searcher all too frequently considers himself at the end of his resources.

### System May Be a Valuable Aid.

Following out a set system of searching for trouble may constitute either an almost certain method of finding what is so eagerly sought, or quite the contrary, a means of wasting much valuable time and effort, with the sole final result of utterly disgusting the searcher with his task. Some of the lists referred to at the opening of this article would, if closely followed, be more than apt to have this result, from which it will be quite apparent that everything depends upon the system. It may seem that the average repairman in a garage goes aimlessly to work in looking for trouble round an engine, but a closer study of the methods employed in a large number of instances will reveal the fact that most of such men, where they have had considerable experience, have developed a system of their own. Practically every autoist does the same. In childhood, we learn most things that are beyond us purely by rote, and our only authority for the existence of a certain state of facts is the book. In the same way the new owner of a car looks to his "little book," but with

the knowledge gained from even a short experience such aids are discarded in favor of the teachings of the latter.

Probably there are few autoists to-day who, in the inception of their careers as such, did not place considerable store by the written word as expressed in the works of numerous authors on the maladies of the automobile, and who, before taking their first plunge, carefully primed themselves in advance with sufficient information to start a dozen balky engines. Strange to relate, though, it proved the hardest thing in the world to apply the knowledge thus gained to the matter in hand, and while everything seemed most beautifully clear as elucidated by the author with the aid of numerous illustrations and easy technical descriptions, the book might as well have been a work on the "infinitesimal interim" as on the automobile, so far as its help went in aiding the beginner when confronted with the reality. Not that it is desired to run down a book, or books in general, but merely to point out that their value is only appreciated to its full on a second or third reading in the light of experience gained during the intervals. It is difficult to appreciate anything that is not understood.

### Make a Study of Cause and Effect.

Modern medicine does not direct its efforts half so much to the cure of the actual ailment as it does to the removal of the underlying cause, and the autoist who wishes to attain to that degree of knowledge where no defection of the motor, regardless of how puzzling it may appear, is sufficient to "stump" him, will do well to bear the fact in mind that there is always a direct and important relation between cause and effect in every stoppage of a gasoline motor. An engine that refuses to start from cold does not offer as good a subject for diagnosis, or the study of cause and effect as does one that has come to an apparently inexplicable stop while on the road. In other words, there is something to be learned from the manner in which the motor stops. A sudden and abrupt failure to fire may almost invariably be traced to the ignition system and just as forcibly points to a lack of current. But no battery "dies" suddenly, so that it stands to reason that a short-circuit or an open circuit, more often the latter and caused by the breaking of a wire or a connection, is responsible for the trouble.

Spasmodic and gradually weakening operation is most often due to a failing battery, or what is its practical equivalent so far as results are concerned, the gradual working out of adjustment of coil tremblers that have become loosened. This parallel is most often true of single and twin-cylinder engines, as the chances of all four tremblers of a four-unit coil getting out of adjustment in the same manner simultaneously is remote, but the resemblance between the two is so great that I have known more than one good set of dry cells to be thrown away for no other cause than that the poor adjustment of the tremblers caused every symptom of an exhausted battery to appear. A timer that has degenerated to a state where it only functions in an erratic manner, at times performing in a normal way for several minutes and then doing all sorts of "stunts," is also productive of symptoms that are frequently thought to emanate from the weakness of the source of current supply, or a gradually diminishing gasoline reserve. In connection with the latter there are most peculiar indications to record.

The last drop always tastes sweetest when there is no more to be had, and this seems to be the case with the gasoline motor as it runs so very well on the few last drops of fuel that a suspicion of impending disaster is furthest from the



mind of the driver. Just why a motor should stop suddenly when running at its best is naturally far more puzzling than where it gives up the ghost only after a more or less prolonged struggle against adverse conditions, and I have known more than one autoist to ardently wish that he could so adjust the carbureter of his motor to give results equal to those that it produces on the last remains of the fuel in the tank. But there is something different about the manner in which the motor stops from lack of fuel after giving this final spurt, and that of its sudden cessation of operation caused by a break in the ignition system—something that experience gives the ability to detect, as is true of so many other things.

#### Getting the Symptoms Confused.

It would be bad for the patient if doctors erred or disagreed in their diagnoses half as often as even the more experienced autoist does in his conclusion as to the cause of the malady, one instance that comes to mind at the moment being a case where the improper running of the motor was put down to the carbureter and every possible means of changing the adjustment of the latter having been resorted to without favorable result, its replacement was seriously considered. So firmly had the victim of the trouble become convinced that the carbureter and nothing else was at fault that it was only upon being shown by actual demonstration that the timer was responsible that he changed his opinion. As the car was of the light runabout type, selling at a low price, the device in question was not of a high order of efficiency, and experience with it on a number of the same cars had shown it to be afflicted with a chronic ailment inseparable from age and which was all too frequently put down to some other cause. This merely consisted of a weakening of the contact springs which so delayed the occurrence of the spark in the combustion chamber that the effect was the same as if the ignition had been retarded to an extreme.

In this connection it is well to remark before going any further, that the timer is very often responsible for the poor performance of the motor, or its stoppage, where the carbureter is blamed. The latter is a thing of mystery at times—even to the thoroughly initiated, and practically always to the beginner, so that it may seem more natural to suspect it than something simpler and more tangible, such as the timer invariably proves to be, for it must either work or fail while the carbureter has many intermediate stages of defection. In one instance that came to light a year or two ago the failure of this essential of the ignition system would have been responsible for the almost entire dismantling of the motor's accessories had it not been discovered in time—and time in this instance meant several hours of wearisome trying this, that and the other, a large part of which was lavished on the carbureter and its auxiliaries. It would be useless to attempt to detail the manner in which this long search was carried out or the endless number of expedients resorted to in trying to discover the trouble, which was finally found to consist of nothing more or less than a loose set screw.

The function of the latter was to hold to the timer on its vertical shaft, a recess in the latter being made for its reception. Owing to the vibration, or some other unexplained cause, the screw had backed out of this countersunk recess just sufficiently to hold at times and let go at others, with the added peculiarity that it always permitted itself to be picked up by the shaft when turning slowly, so that there was little or no difficulty in starting the motor by cranking, no matter how often it stopped. Its periods of continued running varied from one to two minutes to almost half an hour, being punctuated at times by sudden stops and equally sudden resummptions of action, caused by the timer being picked up again before the motor had lost its momentum, so that it automatically took up its cycle again. In the same way the ignition has been blamed for a miss that was finally

traced to a leaking inlet valve which had never been suspected.

As was the case in one of the instances already related, where study of the problem revealed the fact that half a dollar's worth of new timer springs were needed instead of the fifteen dollars' worth of new carbureter that the troubled owner had seriously considered investing in, a little reflection which takes into account all the phases of the matter will frequently not only lead to the discovery of the cause itself, but likewise result in a saving of considerable expense. Experience in giving "absent treatment" to a large number of cases, in other words, advising troubled owners at long range as to the cause of trouble with their cars, has shown that the average autoist is prone to overlook the fact entirely that the devices which are now apparently the cause of so much worry once gave satisfactory service and that for a long period. Failure to remedy the trouble by ordinary means seems to give rise to an insatiable desire to buy new parts or to go to other extremes of expenditure.

If the design or construction of the car were so radically wrong that nothing but a replacement or a redesigning of the part in question would suffice, which some of the owners in question seriously contemplate when confronted with defections of a nature apparently irremediable otherwise, how did the car ever come to give satisfactory service in the first place? Of course, it is a matter of common knowledge that most of the productions of earlier vintage embodied defects of design and construction of one form or another, and that it is possible to greatly improve such cars by redesigning some of their parts in accordance with what has come to be standard practice since they were first turned out.

#### A Little Reflection Will Help.

No one is in a position to know the history of a car so well as the man who has owned and driven it for two or three years, and it seems strange that in the light of the knowledge gained in this manner, that such owners should not reflect that what has given long-continued satisfactory service cannot be made to do so again by proper adjustment or repair. One of the things that is not taken at its full value is the effect of wear on moving parts. Take the wear on valve-operating mechanism as an example; it involves a dozen or more contacting surfaces, loss of metal from which tends to decrease the maximum valve lift and to hasten its closing, the only compensation for which is to be found in the lowering of the valve seat itself by grinding, so that after three or four years' use the valve timing is almost wholly deranged. Checking up the flywheel marking should reveal this.

Trouble has at times been traced to a combination of causes in which both the carbureter and the ignition system were contributors of the greatest importance, where failure of the motor to perform satisfactorily was concerned, and where completely remedying one did not prove effective for obvious reasons. But to go further into detail under the head of what might be termed complications, or, for that matter, any of the subdivisions which have been dwelt upon without any regard to a well-defined sequence, would require a volume.

In all motor trouble, and this comprises more than 75 per cent. of all the ills to which a car is subject to, barring tires, it should be borne in mind that a proper fuel mixture ignited at anything near the proper moment will give some evidence of its presence, and that where the motor will not produce so much as a "cough" under the most long drawn out and skillful ministrations, it has not "gone bad," nor is it "balky," or "hoodooed," or any of the other numerous bad things attributed to it by its puzzled owner. It simply means that one or the other, or both, of these cardinal necessities is not present in a form even remotely approaching that required for operation as the possible range of mixture composition and ignition timing under which a motor will show some signs of life is very great.

## LETTERS INTERESTING AND INSTRUCTIVE

### BALANCE OF FOUR AND TWO-CYCLE MOTORS.

Editor THE AUTOMOBILE:

[1,133.]—Kindly give your explanation of combustion balance as applied to four and two-cycle motors. G. GRANT.  
Bryn Mawr, Pa.

By combustion balance we presume you mean the balancing of the impulses of the motor, as distinguished from its purely mechanical balance, which has reference alone to the parts in motion. In comparing the two types of motors, it may be assumed that a four-cylinder motor is supposed in each case, as this gives the best balance attainable in the four-cycle motor, short of six cylinders. As you are doubtless aware, the pistons of the four-cylinder, four-cycle motor are placed in two groups of two each, the crank throws being arranged at an angle of 180 degrees, a typical arrangement being that in which two pistons in the same plane are placed at opposite ends of the shaft, while the other pair is between them. The impulse stroke of cylinder number one will then be balanced by the compression stroke of cylinder number three, which fires next and is balanced by the compression stroke of number two, the firing of the latter, which is next in order, being balanced by number four, and this in turn by number one, then repeating.

In the two-cycle motor of the same number of cylinders, there is no reason why they cannot fire one, two, three, four, thus permitting the use of a four-throw crankshaft with the cranks set at 90 degrees to one another round the crank-circle, and we believe this is the case in most four-cylinder, two-cycle engines. In other words, the motor of this type is practically the same as the single-acting steam engine, the only idle stroke being that of compression, the impulses thus being distributed much more evenly round the crank-circle than is the case with the four-cycle.

### ENAMEL VERSUS PAINT ON A CAR.

Editor THE AUTOMOBILE:

[1,134.]—There is so much trouble attached to the preservation and maintenance of the finish on the poorly-painted automobile and so much expense attached to the production of a really durable and high quality coach finish, that I have often wondered what objection there could be to the use of bicycle enamel on metal bodies at any rate. As all of us who had wheels will remember, these enamel finishes clung to the steel and presented a new appearance for an indefinite period under conditions of the hardest service. I always have understood that these enamels were applied simply by dipping and baking, without any precautions in the way of a multitude of coats or grinding down with pumice and rotten-stone to produce a polish. So why are not enamels used on automobiles?  
CLARENCE N. STUTTS.

Paducah, Ky.

We know of no reason why enamel should not be extensively used in the manner you mention, and, though without specific information that this is the case, we believe that several manufacturers employ enamel instead of paint. Its use undoubtedly is limited, however, by the considerable plant required for its proper application. Enamel cannot, as you suggest, be satisfactorily put on with a brush, but is best applied by dipping—a process that involves enormous tanks and large stocks of material for anything so large as an automobile body. And, besides the tanks, there are required ovens of similar magnitude, equipped with means for heating, and the maintenance of the temperature with only a minimum variation for many hours at a time. Undoubtedly enameling processes will come more and more into vogue as standardization progresses, unless there are objections to it with which we are not familiar. On this score, as well as on that of its present application, we shall be pleased to give space to anything that our friends in the trade may be interested enough to communicate to us.

### EXHAUSTING ONE CYLINDER ON THE INTAKE.

Editor THE AUTOMOBILE:

[1,135.]—Would you kindly inform me through "Letters Interesting and Instructive" as to whether I would gain anything by inclosing the pipe leading from the carburetor to the manifold through a sleeve and exhausting one cylinder through the sleeve, as per sketch. Have noticed slight popping noise at carburetor, especially at high speed. Carburetor is a Schebler and is new.

My spark plugs are wired through a single coil with a single wire running to the timer from the coil, thus causing both plugs to spark simultaneously. Would I improve matters by putting in a two-unit coil and a two-point timer?  
J. L. DAVIS.

San Francisco, Cal.

We should hardly recommend such an arrangement as that illustrated by your sketch, which we are reproducing herewith. The amount of heat required for this purpose would not necessitate the direct use of the exhaust gases from even one cylinder. Instead of placing a sleeve such as you indicate round the intake, make one of a similar type to encircle the exhaust manifold and lead a somewhat large bore pipe from it to the vicinity of the carburetor, having it end in a bell-mouth so that it will discharge hot air on or against the carburetor itself. This may be found to prove an advantage, but such a very great number of cars run

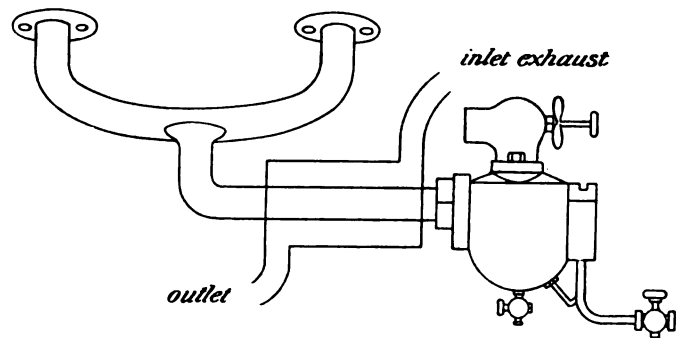

PROPOSED HEATER FOR INTAKE MANIFOLD.

satisfactorily without any provision whatever for warming the carburetor, either by hot air or water, that unless good running cannot be obtained in any other way, it would seem hardly necessary to go to this trouble. The bonnet of the modern car is so tightly inclosed that the air under it is pretty warm at all times when the motor is running. The popping noise at the carburetor is usually caused by a weak mixture, which burns so slowly in the motor that it is still afire or under considerable pressure when the intake valve opens for the succeeding charge.

The ignition of the motor would doubtless be improved either by the retention of the single coil and the fitting of a combined two-point timer and distributor, or the use of a two-unit coil and two-point timer, although motors fitted as you state have often been run for a considerable period without great trouble.

### WHAT IS THE CAUSE OF THIS KNOCK ?

Editor THE AUTOMOBILE:

[1,136.]—I would greatly appreciate your help in finding the cause for a knock in my two-cycle automobile engine. When I start out it seems to pull quite well for a short time, but soon, on a slight grade, begins to knock if I advance the spark or not, and it seems to do best if I keep the throttle about 1-4 open and advance the spark some. I am pretty well satisfied that the bearings are snug and it seems to me like a premature explosion. The only thing I can think of is that there is something wrong with the cooling system. I have drained the water off several times and had one repairer go over the water circulation. How shall I clean it if you think that is the cause? I have had one cylinder off and did not find much carbon. I can feel that the engine has power until this

aggravating knock occurs. I cannot adjust my carbureter (a Schebler) so that the engine will run well with the throttle open and the spark retarded, especially when the car is standing still. Would a stoppage in the gasoline supply account for this? How can I tell if the flow is sufficient? If I open the cock under the carbureter while the engine is running wide open, should the gasoline still run out? The engine has automatic inlet valves.

Oakland, Cal.

#### A SUBSCRIBER.

If your statement that the bearings are snug could be regarded as true beyond a question, there might be some mystery in the knock you speak of, or as you say, it might be due to preignition, but from the remainder of your statement of facts there appears to be little doubt that it is caused by loose bearings—either in the wrist-pins or the connecting rod big-ends. The fact that the motor runs smoothly under no load, or a very light load, and immediately begins to make a knocking sound the moment a load is applied, is an almost certain indication of this, as a motor that is afflicted with a bad case of preignition will show the symptoms of its malady, even when running light.

It is far from desirable to run a motor with the throttle open and the spark retarded; the time of ignition should always be advanced as the fuel supply increases, otherwise there is not sufficient time for the proper utilization of all that is admitted and more or less back pressure is created, due to the fact that the charge is apt to continue burning after the exhaust valve is closed. If the motor will perform well at normal speed when hill climbing, that is, without missing, the gasoline supply is sufficient.

Failure of gasoline to run out of the cock at the bottom of the carbureter would merely be an indication that there was none in it, regardless of whether the engine was running or not, though if such were the case the engine would certainly not be running. The fact that the motor is equipped with automatic valves is somewhat at variance with your statement that it is a two-cycle, unless you refer to the ports or the check valves of the two-cycle type.

### USING THE MOTOR FOR BRAKING.

Editor THE AUTOMOBILE:

[1,137.]—What is the best way of using a motor for a brake? This is a point, I am sure, which merits a good deal of discussion, for it undoubtedly is the fact that many otherwise competent drivers wear down the friction surfaces of the brakes, when a little knowledge of how to handle the motor in such a case would place at their disposal a ready means of retarding the car on long descents without burning up or overheating the brakes proper. The things I most particularly wish to know are: Is the greatest retarding effect secured with the throttle opened or closed? Should the ignition be switched off or not? And under what circumstances should the engine be driven by the car through the lower gears? With the throttle closed so little air is drawn in that the resulting vacuum must, by sucking the piston back on the next stroke, return a good deal of the power that had been absorbed. On the other hand, with the throttle wide open, full charges are inspired so a heavy retarding effect must be produced by the compression, but is not this nullified by the expansion in the succeeding stroke? These considerations make it difficult for me to figure out just what is best. I also would like to be told of some way to save the fuel while using the engine as a brake, for even though the ignition be cut out, the fuel must go through and be thrown away at a rate corresponding with the throttle opening.

ELMER WILLARD.

Dubuque, Ia.

Parts of your letter make it appear that you forget the cylinder of a four-cycle engine functions through a cycle of four operations just the same whether the ignition is off or on. Thus, with the throttle wide open, there is suction, compression, expansion, and exhaust, with the chief resistance in the compression stroke, and this resistance largely nullified by the immediately ensuing expansion which returns much of the power required for the compression. With the throttle nearly closed, there still are suction, expansion, and exhaust, with a resistance due to the production of a partial vacuum during both suction and expansion strokes, which is only partially nullified by the atmospheric pressure behind the piston during what would be the compression stroke had full charges been inspired. It follows, there-

fore, that an ordinary four-cycle motor gives a maximum braking effect when turned over against a closed throttle—a plan that further recommends itself through possessing the incidental virtue of saving fuel. Moreover, this being the case, it is not necessary to switch off the ignition, except to save current, provided, of course, that the fuel supply can be cut off completely. With a two-cycle motor, the conditions are different, and whether the throttle is closed or open, the suction in the one case and the compression in the other, tend to return the power that produced them, thus leaving only the friction, leakage, and heat losses, etc., to produce the desired retardation. The ideal way of using a motor for braking, though it probably would be objectionable practically, because of its complication, would be to have an extra valve mechanism that could be brought into action to the exclusion of the regular valve mechanism, and which would permit compression during each stroke and suction during each down stroke. As for the matter of gears, of course, by engaging a lower gear the car must turn the engine over faster than is required with a higher gear, in this way, opposing the greatest possible resistance to the car's motion. Very few cars will coast very fast no matter how steep the grade with the low gear in mesh and the clutch engaged and the engine dead. For cutting out the ignition, the usual method is simply to switch off the current at the regular switch. A rather more convenient way is to have a special cutout, placed so as to be conveniently operated by hand or foot.

### TO GIVE BRASS AN ATTRACTIVE DULL FINISH.

Editor THE AUTOMOBILE:

[1,138.]—In a copy of "The Automobile," which I have lost, there was a formula to change brass to a blue or green metal finish. Will this wear and stay as you color the brass, or will you have to keep giving it a coat to retain that finish? Will you kindly put the formula in your next issue?

OMER M. SLOAT.

Worcester, N. Y.

To color brass a bluish black, make a solution composed of 15 parts nitric acid, 8 parts cupric sulphate, 20 parts alcohol and 12 parts water. Clean the metal thoroughly and remove every trace of grease, which may be done by dipping in a pickling solution composed of 10 parts sulphuric acid and 90 parts water, afterward rinsing clean in running water. Spread the above solution over the metal, then dry and rub with a clean rag, preferably linen. This is but one of a great number of such formulæ for coloring metal, but it is doubtful if any of them give permanently satisfactory results. It is our impression that the latter are really only obtainable by electrolytic processes and that it would be more economical and certainly more satisfactory in the end to send lamps or similar parts to be given a dull finish to the electroplater.

### STRANGE CASE OF UNEVEN WEAR OF GEARS.

Editor THE AUTOMOBILE:

[1,139.]—I am sending you under separate cover a gear that came out of the differential case of my Pope-Tribune Model 5. You will see this gear is badly worn on one end, while the other end is not worn away. The three gears that mesh into the left-hand axle are all worn like sample, while the other three are not worn any. The car has been run about 4,000 miles. Everything about the rear axle except these three gears is in good condition. What would cause these gears to wear in this manner?

J. R.

Claremont, N. H.

We are in receipt of the differential pinion to which you refer and must admit that the case is a puzzling one, without further information than the fact that the gears are worn as you state. We have inquired of the agents of the car in this city, but they do not recall ever having had a similar case. However, the cause of this one-sided wear can only be due to two things, acting either alone or in conjunction with one another. Either the load has been carried almost entirely on this side of the differential, or through some accident, the pinions in this side are of poorer material than those of the other, or, as already stated, both these causes may have been operative. The case is an interesting one,

and we should like to hear from any of our readers who have come across anything similar. The differential is the spur type commonly employed on low-priced American cars.

#### AUTOMOBILES FOR FREE RURAL DELIVERY.

Editor THE AUTOMOBILE:

[1,140.]—I am a subscriber and studious reader of your excellent journal, and would like to say a few words in your "Letters Interesting and Instructive." Why is it that there are not any machines designed and built for rural free deliveries use? I believe there would be a good demand for a good machine adapted for that special purpose. I have a plan for a machine of that sort, which has been pronounced by several as A 1, and would like to consult with some small manufacturers or some one contemplating automobile manufacturing. I have made this a special study for several months and sincerely believe this a good field for a good medium priced machine designed for that special purpose. **DELBERT DARE.**

South Bend, Ind.

There is no doubt that the free rural delivery service of the U. S. Mail forms a most excellent field for a light and medium-priced car capable of standing up under hard and continued service, and while there are a number of machines on the market which may be considered as coming within this classification, there is still room for competitive effort, as no great numbers of any one make of machine have been adopted, either by individual carriers or by the Government. The postal officials of the latter in charge of this department, have, however, been doing considerable experimenting along these lines, and successful trials of small air-cooled machines have been made during the last year or two. These have led to the official adoption of several cars, but there is a tremendous field for automobiles of this type, not alone in the government service, but for the farmer and others living in the rural districts. You will find the announcements of quite a number of builders of small cars in our advertising columns, and we should recommend your getting in touch with them by correspondence in furtherance of your plans.

#### A MOST PECULIAR CASE OF TROUBLE.

Editor THE AUTOMOBILE:

[1,141.]—I have a two-cylinder 11-horsepower two-cycle engine in a 21-foot boat which makes about eighteen miles per hour. I used it all last summer, and at the end of the season I had some peculiar trouble with the spark plugs in the rear cylinder. As soon as I would advance the spark and speed up the engine the plug would get so hot that the metal point on the end of the mica center would melt off and the rest of the plug would blow out of the cylinder, while the cylinder would remain cool. This happened to four mica plugs. When I tried a porcelain plug the plug would get so hot that the cylinder would fire at the wrong time. I had this trouble with the rear cylinder only. Can you tell me where to look for the trouble? Thanking you in advance,  
**Utica, N. Y. TWO-CYCLE.**

We must admit that no case in any way similar to this has ever come to our attention before and we would not even venture to suggest an explanation any more out of the ordinary than that of a failure of the cooling water to circulate through the jacket of the cylinder in question. This would appear to be such a commonplace cause of the trouble and one so readily detected by anyone familiar with such motors that we presume it has been taken into consideration. We would, therefore, refer the query to the attention of our readers, confident that some one of them can doubtless give a better reason should the foregoing not have been the cause.

#### CONCERNING EXHAUST VALVE TIMING.

Editor THE AUTOMOBILE:

[1,142.]—Will you kindly give in your next issue of "The Automobile" the number of degrees the crank should have traveled when the exhaust valve should commence to open; also the position of crank when it is closed; what is the position in degrees when the intake opens and closes when mechanically operated? **A. I. Q.**  
**Swampscott, Mass.**

We believe it is customary in American practice to have the exhaust valve open about 30 to 35 degrees on the crank-

circle in advance of the lower dead center, and have it close again either when the crank is exactly at the upper dead center or 3 to 5 degrees beyond it. The intake valve is set to open at the same time as the exhaust valve closes and remains open until the crank has passed the lower dead center some 15 to 20 degrees on the crankcircle. This is termed the lead given the valves, and its extent depends to a large measure upon the speed of the motor, its function being to insure the scavenging of the combustion chamber in the case of the exhaust and the aspiration of as full a charge as possible in the case of the intake.

#### THE POSITION OF AUTO HEADLIGHTS.

Editor THE AUTOMOBILE:

[1,143.]—Some years ago I read a suggestion to the effect that automobile searchlights could with advantage be carried as high on a car as practicable, even to the extent of placing them immediately beneath the forward end of canopy tops. The argument for this was that the higher the lamp the better the illumination is thrown into the small hollows and irregularities of the road. Since then I have seen a number of searchlights thus carried on canopy-top cars, besides the now common mounting on the dashboard. It has struck me that the same idea might be with advantage applied to the placing of the ordinary turn headlights, which, as usually mounted, throw their beams so low as to make every small inequality appear like a yawning pit, because of the intensely black shadow it casts. Has it never been attempted to mount these lamps higher—on the sides of the radiator, say—and does any one sell fixtures or brackets capable of being thus employed? And what merit do you think there is in the whole idea, and what, if any, are the objections to it? **ARNOLD WRIGLEY.**

Chattanooga, Tenn.

While your suggestion is not, as you point out, altogether new, it certainly seems to merit the consideration of lamp makers, car builders and users generally. There is no question but that the very low position of many lamps largely discounts their practical value in the manner you mention, despite the provision of ample illuminating power. Some manufacturers, however, are evincing a tendency to mount the front lamps on very high brackets, and in at least one case—that of the Northern cars—the headlights are bracketed on the substantial front ends of the forward fenders, a placing that seems more desirable than your idea of brackets on the radiators. We shall be pleased to hear what, if anything, any one may have against these suggestions.

#### DIFFERENCE BETWEEN LIVE AND DEAD AXLES.

Editor THE AUTOMOBILE:

[1,144.]—What is a live axle and what is a dead one? Also difference between floating and live axle, if any? **MPLS.**  
**Minneapolis, Minn.**

A live axle is one that is utilized to drive the car, in other words, a moving axle, while a dead axle remains inert. The former type is employed on shaft-driven cars on which the power is transmitted to the driving wheels through the live axle, while the second type, or dead axle, is a feature of double side-chain driven cars in which the axle does not move in connection with the driving of the car. There is no difference between a floating and a live axle, generally speaking. The former term is used because what are known as the driving shafts of a live axle, i. e., the two halves which extend from the differential to the two driving wheels are not firmly bound at either end. They are usually held by jaw or similar clutches at either end, so that they may be literally said to float, hence the term.

#### GAS IS WHAT PRODUCES THE HEAT.

Editor THE AUTOMOBILE:

[1,145.]—Will you please let me know through your columns which will heat a motor most, too much air through the carburetor or too much gas? **F. S. P.**

A slow-burning mixture, by which is meant one that contains either too little gas or too much gas, is apt to over-



heat the motor, but of the two the latter is naturally by far the worst, as it is the burning of the gas that produces the heat. As long as there is sufficient air to burn the gas, the more of the latter there is the more heat will be produced. But the overheating is not due so much to the fact that more heat is produced, as that, in the case of the slow-burning rich mixture, the heat is not utilized, a far larger percentage of it going to the cylinder walls and other parts of the motor. Probably the over-rich mixture does not produce as many heat units as the correct mixture would, but those of the latter are quickly utilized and the waste as quickly disposed of, from which it will be apparent that it is really the time element that is of the greatest importance.

#### INTERESTED IN DAIMLER DRIVER'S CERTIFICATE

Editor THE AUTOMOBILE:

[1,146.]—Will you kindly inform me through the columns of your journal if you know of a chauffeur's certificate given by the Daimler Company to men who pass an examination under their supervision? If so, kindly state where information can be obtained in regard to the conditions.  
H. HUBBERSTEY.  
New York.

We are not aware of any chauffeur's certificate granted by the German Daimler firm. The British Daimler Company has recently inaugurated a scholarship scheme the candidate chosen after examination being entitled to two years practical and theoretical training in their works and payment of \$500 per annum. At the completion of the two years' term the holder of the scholarship may be retained in the company's works at a salary of not less than \$750 per annum. There are also four minor scholarships granting the same facilities, but fixing payment at \$100 per annum. A number of European firms train mechanic apprentices, but training of drivers is now rarely undertaken by the factories.

#### WILL MR. DURYEA PLEASE OBLIGE?

Editor THE AUTOMOBILE:

[1,147.]—I want some information about the first public competition in a race of cars in the United States. I believe it was held in Chicago and that a Duryea won. I am not positive, however, and if you could tell me how many cars participated, how long the course was, and the time, I would be very much pleased. Your paper is fine and I couldn't get along without it.  
Milton, Pa. MYRON L. DICKSON.

As Charles E. Duryea, of Reading, Pa., now consulting engineer of the American Motor Car Manufacturers' Association, was the winner of the race in question in a car of his own design and build, we should prefer to have him give the facts, which we have no doubt he will supply us with for publication in a forthcoming issue.

#### TO SOFTEN AND PRESERVE LEATHER.

Editor THE AUTOMOBILE:

[1,148.]—Will you kindly give me a receipt for softening and preserving leather, color dark red.  
G. R. FERNALD.  
Wilton, Me.

Wash the leather with a little soft soap and warm water, wiping it thoroughly dry. Then prepare a dressing composed of lard, 100 parts; castor oil, 20 parts; yellow wax, 25 parts, and white vaseline, 30 parts. The latter is given in a general collection of such formulæ, and we cannot guarantee its efficacy. Any reader who knows of a better one with which he has personal experience in applying to the upholstery of his car, may give it in these columns, if he wishes to do so.

#### INFORMATION WANTED CONCERNING DRY CELLS.

Editor THE AUTOMOBILE:

[1,149.]—Among your letters note particularly No. 1,090, regarding dry cells. I second the latter part concerning reprinting Mr. Jackson's letter, being a new subscriber who has had much trouble

with ignition; cannot use anything but dry cells, as I have no facilities for recharging storage batteries.  
A. R. JACOBS.

Dillon, Mont.

Mr. Jackson's article concerning the use of the dry cell appeared in the issue of THE AUTOMOBILE of May 23, 1908, of which copy will be forwarded upon request.

#### FOR MR. MUNCH HAUSEN TO DIGEST.

Editor THE AUTOMOBILE:

[1,150.]—Possibly the solution of my experience in the matter of consumption of cylinder oil may be of interest to the writer of letter No. 1,109, published in your issue of January 16. During the past two years I have driven a Rambler Type 2 machine (double-opposed cylinder, 5-inch bore, 6-inch stroke) 3,744 miles with a total consumption (crankcase and cylinders) of seven gallons of cylinder oil—an average consumption of one gallon of oil for each 535-mile run, using round numbers. The engine is now and has always been in perfect condition.  
C. J. W.  
East Acton, Mass.

Editor THE AUTOMOBILE:

[[1,151.]—In your issue of January 16, M. H., of New York, doubts the statement of J. G. C., of East Orange, as to his averaging \$81.09 miles on one gallon of oil. Although that is a fine average on that quantity of oil, it is a well-known fact that a great many cars of 20 horsepower are doing at least 100 miles on two quarts of oil all the year round. And I personally know of a certain make of car of 14 horsepower that uses only one quart for 100 miles, so I think that J. G. C. has made no error in his statement.  
W. A. FOSDICK.  
Dallas, Tex.

#### AGREES WITH DIAGNOSIS OF VIBRATION.

Editor THE AUTOMOBILE:

[1,152.]—In your column "Letters Interesting and Instructive," in letter No. 1,097, on "A Problem in Vibration," you say, if your idea is right, on a back-handed motor the vibration should be greater. I will say that I have noticed the same thing on the cars that I drive. Am at present working on four or five Stearns and a couple of Oldsmobiles. The Stearns are back-handed motors and the vibrations are always greater on the left-hand side than the other, while the Oldsmobiles, being the opposite, the vibration is on the right. The Stearns are chain driven and the Oldsmobile shaft driven. I have often noticed the fact of the greater vibration, but until I saw this article I never gave it much thought.  
Montello, Mass. JAMES E. FAUNCE.

#### HERE'S A CHANCE FOR THE A. A. A. LAW BOARD.

Editor THE AUTOMOBILE:

[1,153.]—I have just received a copy of the rules and regulations of the National Park in Wyoming, and I note that automobiles are absolutely prohibited from passing through the park. I am informed that the grades are fine, good and wide, and that there is no earthly excuse for excluding automobiles. The season opens about July 1, and, if enough influence is brought to bear with the Secretary of the Interior, these rules can be rescinded.

If your journal wants to receive the everlasting gratitude of a large number of autoists, this is a chance to get it.

Yosemite is open.  
Spokane, Wash.

C. P. THOMAS, M.D.

#### A FOUR-WHEEL DRIVE WITHOUT AXLES.

Editor THE AUTOMOBILE:

[1,154.]—I have noticed letters in "The Automobile" regarding a four-wheel drive, and am accordingly giving you a description of a car of this kind that I am now building. The car is built without axles, the wheels running in independent frames, making a more simple and durable form of construction. All four wheels are driven, the front truck turning to steer the vehicle. I am now using a 24-horsepower motor on the rear truck with a chain drive, but a gear drive is equally applicable. No differential is employed.  
Reno, Nev. P. A. HELCHER.

#### FOR "INTERESTED READER, DETROIT, MICH."

If the correspondent who has contributed a letter to this department regarding the controversy between the advocates of the four and six-cylinder motors, signing it as given above, will make known his name and address, the letter will be printed in the usual course. This information is not wanted for publication, but merely as evidence of good faith. Names and addresses will never be published where a request is made to that effect, but no communications should be sent anonymously.

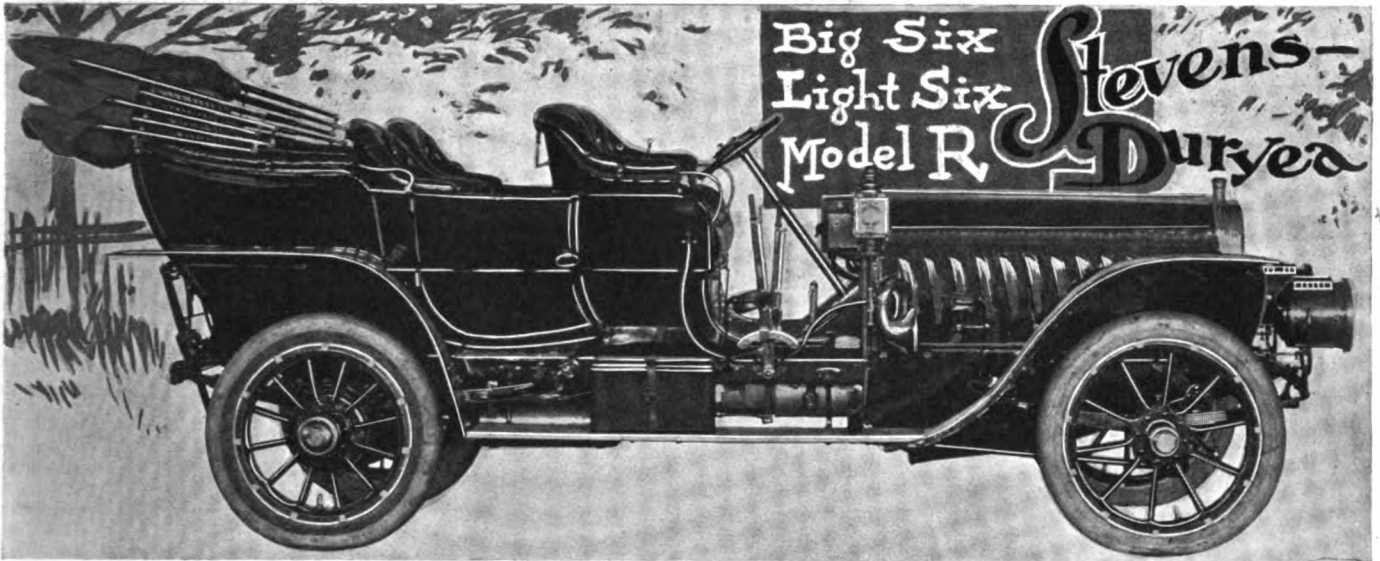

THE success of the Stevens-Duryea cars may well be termed the reward of consistent adherence to a well-outlined policy adopted as the result of confidence in a particular type of car, as the builders, the Stevens-Duryea Company, Chicopee Falls, Mass., were one of the first manufacturers to market six-cylinder cars in this country. Realizing from the outset, however, that what was needed was not merely a fifty per cent. enlargement of the four-cylinder motor as it then stood—in other words, not a motor half again as powerful, but one of the same power with the advantages of the greater number of cylinders, the Stevens-Duryea engines are not merely replicas of their four-cylinder type, but have been designed particularly with a view to meeting all the conditions imposed by the new order of things. Two models are listed—the “Light Six” and the “Big Six,” as they have come to be known familiarly, their official titles being Model U, which is the 35-horsepower car, and Model S, the 50-horsepower type.

In addition to having been close adherents of the six-cylinder type of car from the earliest days of the multi-cylinder engine in this country, these builders have likewise devoted a great deal of attention to evolving a power plant that is distinctive in a great many features, so that it is natural that the engine in both the small car and its more powerful brother should be distinguished by the same characteristics. The chief of these is the unit form of construction and upon the value of this in the successful building of a six-cylinder automobile motor the builders of the Stevens-Duryea cars lay great stress. They were the pioneers in this field to adopt a three-point form of suspension for the motor, clutch and change-speed gear, which may be thus combined in one rigid unit, so that no amount of torsional strain of the car's frame or other parts can be transmitted to the power plant, this being but one of the numerous inventions of J. F. Duryea. The great value of such a support in the case of the six-cylinder car is that it insures absolute permanency of alignment to the extra long crankshaft where most needed.

As already mentioned, the description of either of the Stevens-Duryea motors will apply in large measure to the other. The cylinder castings are made separately and the valves are all placed on the same side so as to be operated from a common camshaft, the

valves themselves being made interchangeable. The connecting rod and main bearings in the Model U, or “Light Six,” are babbitt bushings, while the main bearings of the 50-horsepower car are of the annular ball bearing type, thus requiring but a minimum of attention. The flywheel is placed at the forward end of the motor in each case, this being one of the most distinctive features of the Stevens-Duryea design, while the crankcase supporting arms, of which but two are employed, are placed at a point less than a third of the length of the crankcase from the forward end and are cast integral with it. Throughout the design it has been the aim of the builder to minimize the number of small parts. This will be apparent in the use of a single camshaft, while a second shaft driven through spiral gears from the camshaft takes care of all the motor accessories, operating the large centrifugal pump, the ignition timer and the oiler, the last-named being run through the medium of a flexible shaft extension.

The crankshaft is a one-piece forging ground on the journals to an accurate fit, the clutch member and flywheel fastenings being of the taper and key type, locking with a nut instead of the more usual form of flange construction. A commendable feature is to be found in the careful marking of the flywheel rim to indicate the valve timing, so that the latter may always be accurately readjusted after taking

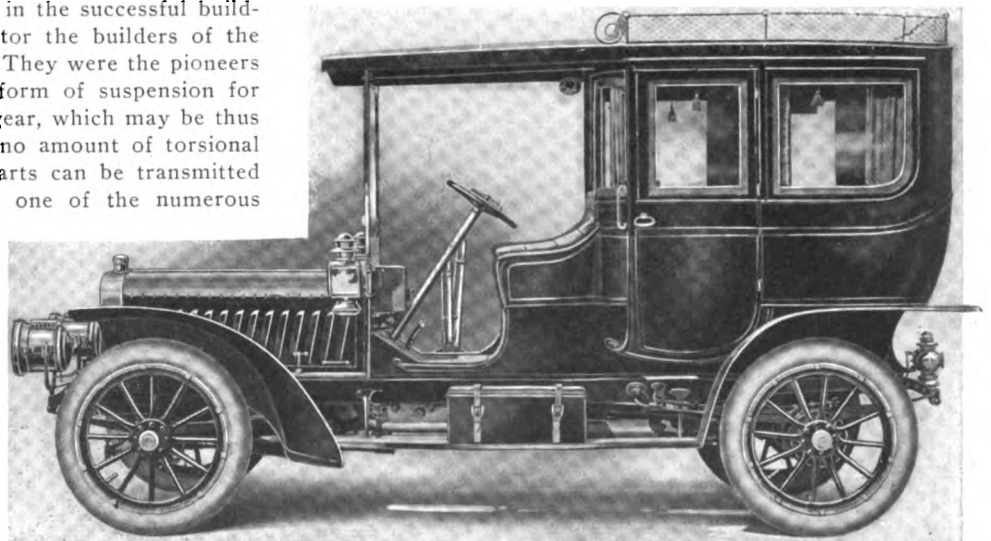

THE STEVENS-DURYEA MODEL U, OR “LIGHT SIX,” LIMOUSINE IN COMPLETE RUNNING ORDER.

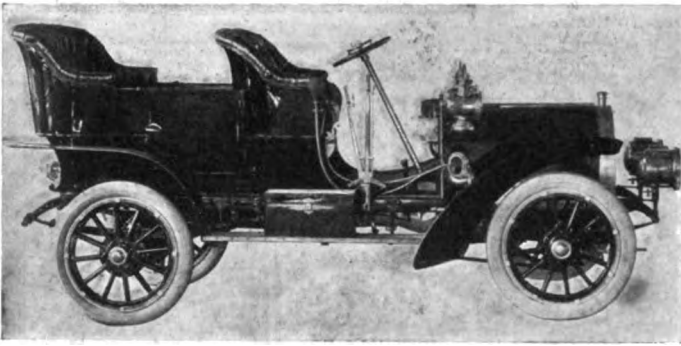

THE MODEL R, 20-HORSEPOWER, FOUR-CYLINDER TOURING CAR

the motor down. In the smaller model provision is made for the withdrawal of the camshaft through a hole in the flywheel, while in the larger car it is necessary to dismount the flywheel itself before this can be done. The timing gears are marked at their meshing point to insure accurate replacement of the camshaft. The manifolds have been made as simple as it is possible to do so on a motor of this number of cylinders, this having been attained in large measure, where the exhaust is concerned, by dividing it into two independent parts. The carbureter employed is of an exclusive design, and in the case of the Model S, or 50-horsepower car, is provided with a double jet, and there is special provision made for supplying it with warm air from the motor in addition. A float-feed is used in both cases. A six-feed mechanical oiler with an individual pump for each lead is conveniently located on the dash and takes care of the essential of lubrication. Ignition is of the high-tension type, while a cellular radiator supplied by the large pump shown is employed for cooling.

Although bolted together in one rigid unit by means of a cylindrical casing of aluminum alloy, none of the parts of the motor, clutch or gear set are any the less accessible on that account, as will be quite evident from the view showing the manner of removing the multiple disc clutch merely by the lifting off of the sectional portion of the housing which incloses it. In the Model U this clutch consists of a series of cork-faced brass discs alternating with a series of steel discs, the driving member connected with the engine shaft carrying the first set and the driven member the second. The two sets of discs are forced together by a powerful self-contained spring carried in the driving member. Adjustments for wear are easily made by means of a series of milled grooves, an adjusting pin and nut and six holes in the milled grooves of the driving member, which combine to make adjustment practically automatic, as the nut can only be locked at certain points. The clutch may also be dismounted bodily with but little trouble.

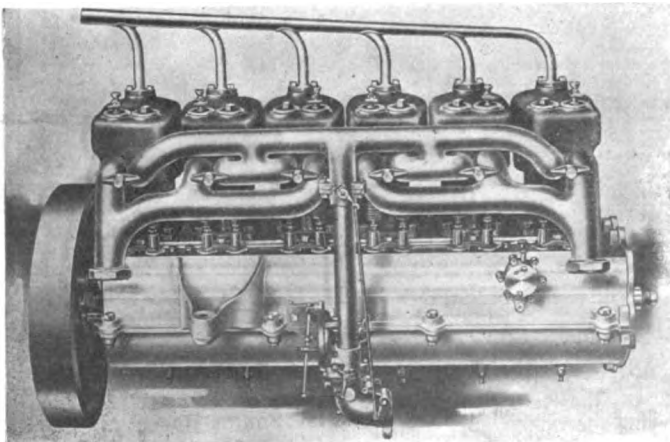

INLET SIDE OF THE MODEL U SIX-CYLINDER MOTOR.

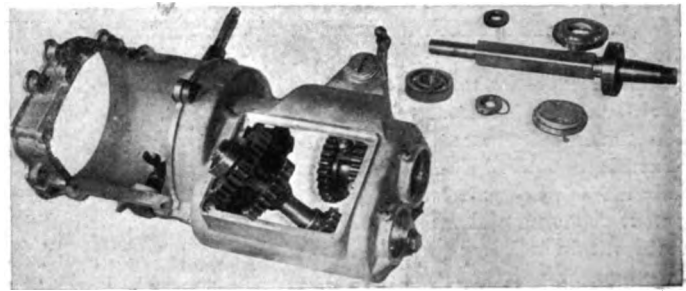

THE THREE-SPEED GEAR SET SUPPORTED ON BALL-BEARINGS.

The gear set is of the standard sliding type and provides three forward speeds and the usual reverse, being the same on both cars. A patented self-finding device is employed on the shifting lever. Compactness of arrangement and a saving in weight and necessity for adjustment are gained by the use of annular ball bearings on the "Big Six." The final step in the transmission of the power is by means of a propeller shaft and live axle. Two sets of brakes are employed, the external contracting pair, or running brake, being

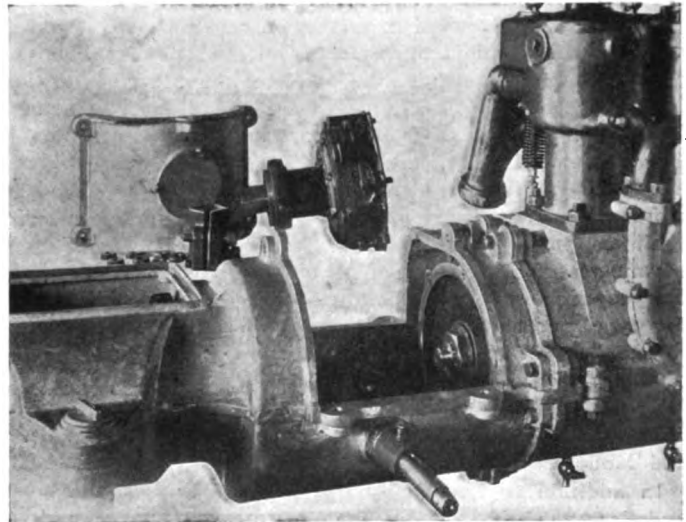

HOW THE MULTIPLE-DISC CLUTCH MAY BE DISMOUNTED.

pedal-operated in the usual manner, while the emergency brake is composed of the internal expanding members, which are operated by the hand lever.

Some of the other specifications of the small car are an I-beam forged front axle, chrome nickel-steel frame, 40 and 48-inch semi-elliptic springs, 114-inch wheelbase and 34 by 4-inch tire equipment on all four wheels. In the case of the 50-horsepower car, the wheelbase is 122 inches and the tire equipment consists of 36 by 4-inch front and 36 by 5-inch tires on the rear. Hess-Bright ball bearings are used throughout in this car. The Model R, four-cylinder, 20-horsepower touring car is also continued.

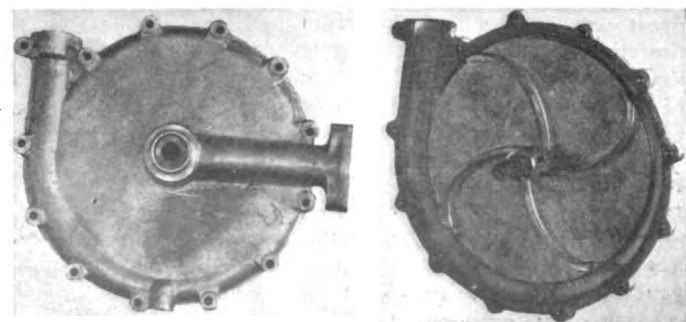

DETAILS OF THE CENTRIFUGAL CIRCULATING PUMP.



STUDEBAKER LIMOUSINE, MODEL H, 30-HORSEPOWER.

“FROM the viewpoint of the engineer, the gasoline automobile of the present day does not differ radically from a type that was accepted as standard almost three years ago. The problems that confront the manufacturers of to-day are of an educational nature. The day of exclusive features, which have been brought up by clever salesmen and thrown at prospective customers as ‘talking points’ is rapidly passing. The automobile of to-day does not depend upon sensationalism for its sales. It passed the experimental stage years ago.” The foregoing, which is quoted from the announcement of the Studebaker Company, South Bend, Ind., is given in explanation of the fact that it is not the business policy of this house to bring out yearly models of cars, such changes and improvements as are found to be necessary being made from time to time, the production of their different models neither being delayed nor precipitated by calendar dates. That this is sound business common sense has been commented upon editorially in these columns but recently.

Their present line consists of a 30-horsepower 5-passenger gasoline car, a 40-horsepower 7-passenger gasoline car and a complete range of electric vehicles for both pleasure and commercial service, the appended description, however, referring only to the chassis of the gasoline cars. In the case of both models only recognized

standards of automobile engineering have been followed, as a short résumé of their more salient features will show. Pressed steel frames of the usual channel section form the foundation in each case, the motors are of the four-cylinder vertical type, employing twin-cylinder castings with integral jackets, and a centrifugal, gear-driven pump is used to circulate the cooling water.

One point in particular will strike the observer who is familiar with the majority of American cars and the details of their power plants, and that is the accessible location of the

carbureter, this essential, in many cases, having had to make room for other accessories placed on the same side of the motor and in consequence being crowded into a most “ungettable” location. Ignition is of the low-tension type which the designer of the Studebaker chassis has so consistently adhered to and which has been brought to such a high state of development in this instance during the several years that the car has been on the American market. The source of current consists of a Simms-Bosch low-tension magneto, so arranged that it can be readily removed

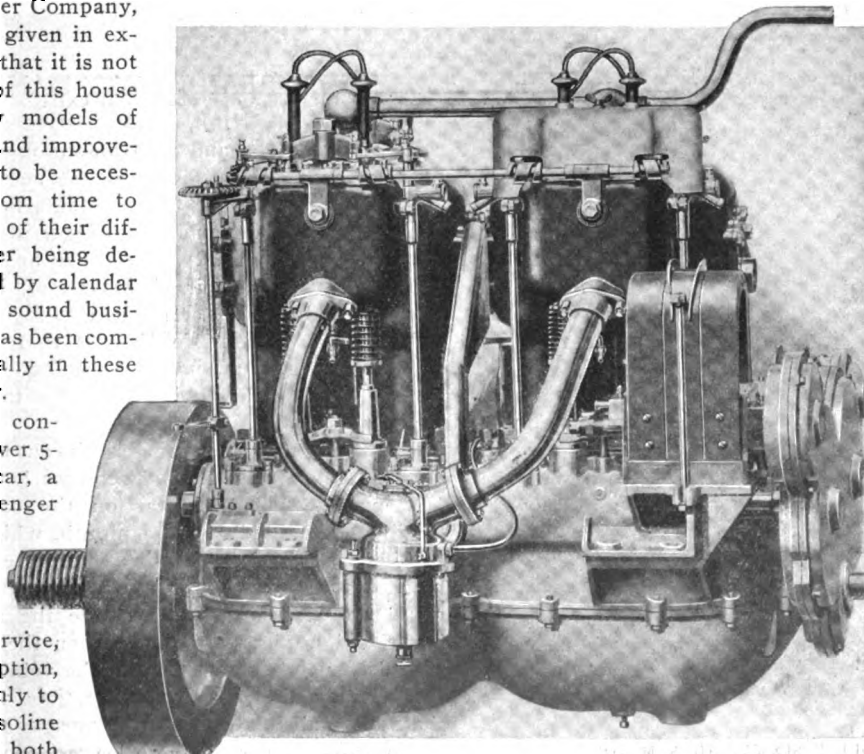

[POWER-PLANT OF THE STANDARD 40-HORSEPOWER STUDEBAKER CHASSIS.]



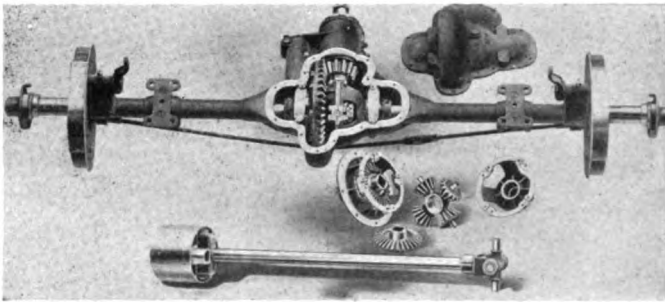

TYPE OF REAR-AXLE DRIVING UNIT EMPLOYED.

without disturbing any other part of the mechanism and so that it can be replaced without the necessity of retiming it to the motor. While the chassis in question show a great similarity in the majority of features, there is one in which they differ, and that is in the type of gear-set, or rather the method of its operation, in the case of the smaller car.

The 40-horsepower seven-passenger car is equipped with a slide change-speed gear, the shafts of which are mounted in annular ball bearings and which operates on the selective plan of gear-changing, while on the 30-horsepower chassis the progressive type of gear-set that has proved so eminently satisfactory in service on this model in past years has been retained without a change.

On both models the brakes have been made unusually large and substantial, and in the case of this essential also

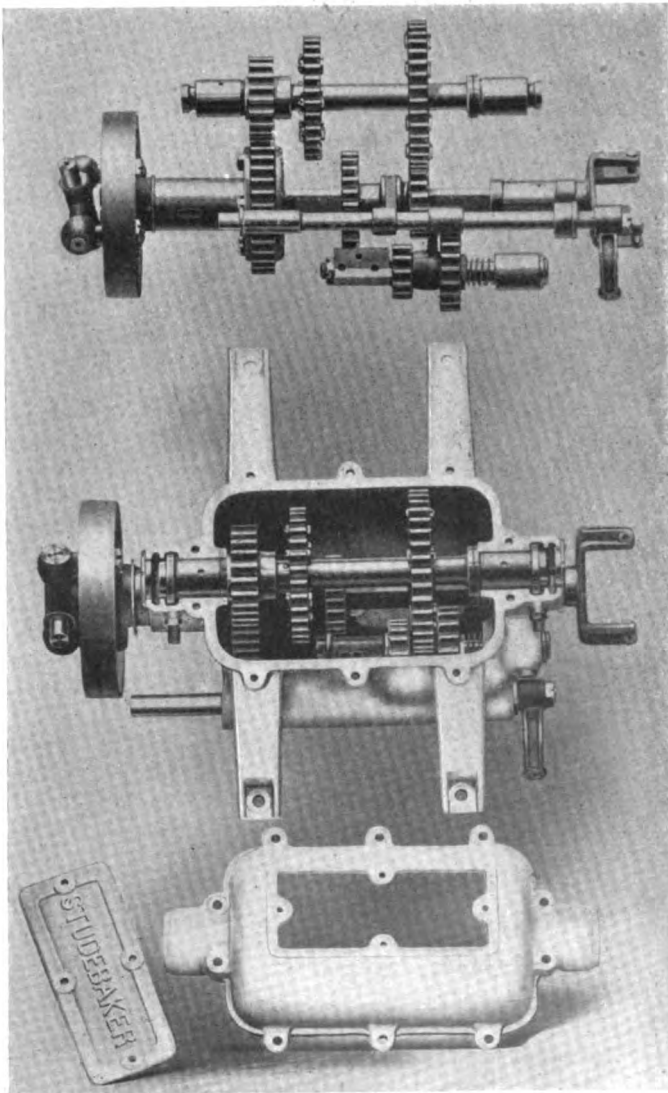

ESSENTIALS OF THE TRANSMISSION, 30-HORSEPOWER CAR.

there is a slight change to be noted between the two chassis. On the smaller the pedal brake used for running service operates on a drum placed on the transmission, while the emergency brake consists of drums mounted on the driving wheels and is operated in the usual manner by means of a side lever. On the 40-horsepower chassis both sets of brakes are concentrated on the rear hubs, being of the standard internal-expanding and external-contracting type. A feature of the gear-set of this chassis is the provision of the direct drive on the third speed, the fourth speed being a step-up for speeding only, while the gear-ratio on the third speed, or direct drive, is made suitable for touring over the usual types of roads found in this country, as well as for overcoming anything but very stiff grades.

In both cases the forward axles are of the standard I-beam section and are drop-forgings of nickel-steel, while the rear axles are of the floating type. On the larger car, the latter is reinforced by a pair of side jack rods in connection with the central torsion rod of the propeller shaft drive. Comparing other features of both these cars, it will be realized how closely they adhere to the highest recognized standards as represented by current engineering practice in this field. The motors are conservatively rated, the dimensions of the larger, of 40 horsepower, being 4 3/4-inch bore by 5 1/4-inch stroke, its output being produced at a comparatively low normal speed; the smaller car is equipped with a motor the dimensions of which are 4 1/2-inch bore by 5 1/4-inch stroke.

The valve operation is identical in both cases, being of the direct thrust type, with both valves of the same size, while the motor accessories are the same in both instances throughout, an automatic carbureter, centrifugal pump, cellular radiator and positive type of mechanical force-feed oiler of the same make taking care of these essentials on both cars. The motor is protected from beneath by an enclosing aluminum pan, while the dash is made of concave form and of pressed steel. The suspension consists of semi-elliptic springs front and rear, the only difference between the cars being that of dimensions. The wheelbase of the smaller is 104 inches and its tire equipment consists of standard clincher measuring 34 by 4 inches on all four wheels, while the same dimensions in the case of the larger car are 114 inches for the wheelbase and 34 by 4 1/2-inch tires.

#### WHY THIS REAL ESTATE MAN USES AN AUTO.

ASBURY PARK, N. J., Jan. 27.—George W. Pittinger is a real estate broker and also an automobilist. No. 6 is his registration number, showing that he was one of the first motorists in this State to take out a license.

As a real estate man Mr. Pittinger, with his automobile, is in a class by himself. The other brokers use horses and carriages to take their clients about, but Mr. Pittinger is thoroughly up to date. It is safe to say that, all things being equal, people looking for houses to rent or buy call upon the man with an automobile first and have him take them out in his machine, going right by the other agents who have horses.

According to Mr. Pittinger his automobile is more economical, more reliable, and requires less care than a horse. His expense bill last year on the car (a single-cylinder Cadillac) averaged \$13.50 a month, which included the care of the car, repairs, gasoline, etc. He was able to do as much business with a single car as other real estate men could do with two rigs, because the automobile, unlike a horse, did not grow weary. Then there was not the need of a driver to occupy space in the vehicle, nor the necessity for hitching the machine every time a stop was made, so that, taken all in all, the advantages of the automobile in the service of this up-to-date real estate man saved its own cost many times over by reason of the increased business done.

**TESTS OF GRAPHITE ON BALL BEARINGS.**

There have from time to time appeared articles in the various trade papers condemning the use of graphite as a lubricant for ball bearings, says *Graphite*. Professor Goss, late of Purdue University, has made some extensive tests with Dixon's Ticonderoga flake graphite as a lubricant for ball bearings combined with kerosene oil, lard oil and vaseline, and found that friction losses were very much reduced and the bearings made to carry a heavier load. The following are extracts from Professor Goss' report.

The general appearance of the machine used in making the test is shown by Figure 1. The bearing tested was a grooved ball-thrust bearing and was made by the Standard Roller Bearing Company of Philadelphia, Pa. It consists of two hardened steel rings, each having a race to receive the balls. The bearing fits a 1 5/8 inch shaft and contains 23 7/16 inch balls. The lower race is caused to revolve through the action of the machine, while the

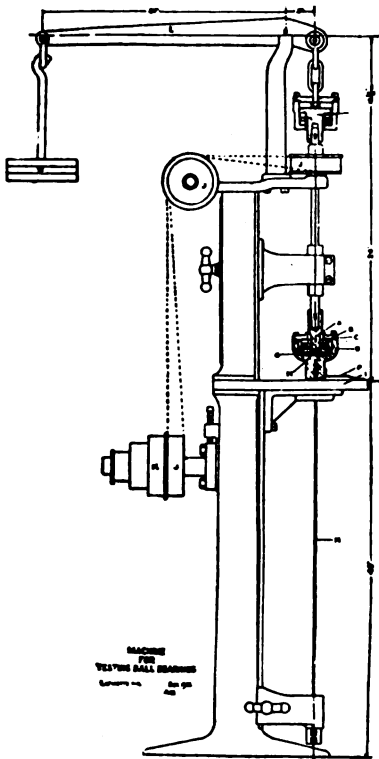

FOR TESTING BALL BEARINGS.

upper one is fixed in position. The pressure imposed upon the balls is regulated by means of weights applied to the lever arm, which is of such length that each ten pounds applied to the weight-pan gives a reaction of 90 pounds along the line of the spindle and thence to the test ball bearing.

It has been shown by previous experimentation that graphite can be efficiently applied as a lubricant when mixed in small quantities with oil or grease. Following this practice, six series of tests were run; the lubricant employed upon the test ball bearing being, respectively, kerosene, a mixture by weight of 96 per cent. kerosene and 4 per cent. graphite; lard oil, a mixture by weight of 96 per cent. lard oil and 4 per cent. graphite; vaseline, a mixture by weight of 96 per cent. vaseline and 4 per cent. graphite; the graphite in all cases was Dixon's Ticonderoga flake graphite.

As the result of these tests Professor Goss says in part that the following general conclusions may be drawn:

"A combination of graphite and lard oil makes a lubricating mixture which, when applied to ball bearings, will accomplish everything which lard oil alone will do and which at the same time will give a lower frictional resistance of the bearing and permit a large increase in the load which it may be made to carry. An oil as light as kerosene, when intermixed with graphite, will be converted into an effective lubricant for ball bearings when operated under light or medium heavy pressure."

**AN IMPROVED FORM OF STEP BRACKET.**

It has been customary with a number of automobile manufacturers to employ drop-forged brackets, or hangers, to support the running boards on their cars, but in view of the service these parts are called upon to perform this forms a comparatively expensive method of producing them.

The engineers of the Parish & Bingham Company, Cleveland, O., have made a study of this apparently unimportant part of a car, and as a result have found that both the drop-forged and the pressed steel hangers have their disadvantages. The latter are said to develop a weakness where they are riveted to the side frame and where they are bent to conform to the running board. They have accordingly designed a combination T iron and pressed-steel bracket which is shown by the accompanying reproduction from a blue-print. The illustration shows it riveted on to a section

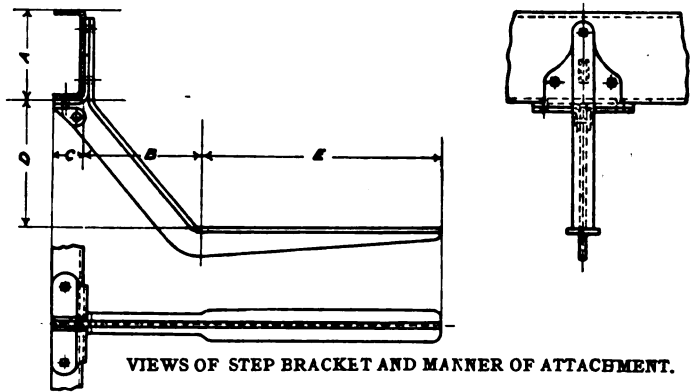

VIEWS OF STEP BRACKET AND MANNER OF ATTACHMENT.

of a side rail in such a manner that the T iron, pressed steel pieces and side rail become a composite whole when the job is finished. By referring further to the print, it will be seen that the dimensions B, C, D and E can be varied to suit the requirements of the individual manufacturer. Strength and rigidity at vital points are the advantages claimed over the pressed steel hanger, and economy of manufacture over the drop-forged type of the same style. The makers call particular attention to the pressed steel pieces on both sides of the hanger under the side rail, which act as a brace to prevent any lateral movement, a construction that is rather novel in the application in question.

**THE MONKEY WRENCH IN AN EMERGENCY.**

The writer was once called upon to get an automobile in running order after it had met with a collision, says E. A. Charles in *The American Machinist*.

The car was standing along the roadside out in the country, with the cooler and its supporting angle all twisted out

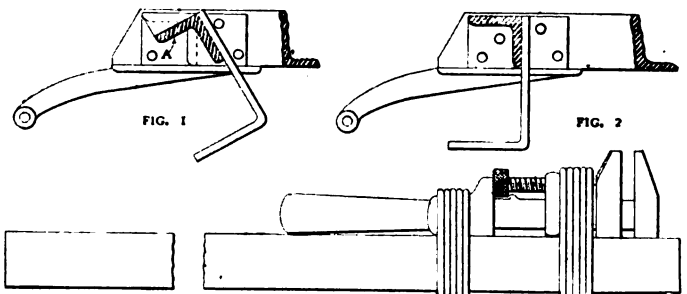

HOW A MONKEY WRENCH SERVED A USEFUL PURPOSE.

of shape. This cooler-supporting angle presented an appearance about as shown at A, Fig. 1, while it should have been straight, as in Fig. 2. To get the car running it was necessary to get this cross-member straightened. The only available tool was a monkey-wrench.

A wooden bar 6 feet long by 3 inches square was found along the roadside, and the wrench was fastened securely to one end of this by means of a wire, as shown in Fig. 3.

With this long lever arm on the monkey-wrench, the steel angle was straightened very easily, the cooler was placed in position and the car proceeded on its journey.

### THE AMERICANIZED HELE-SHAW CLUTCH.

One of the most important developments of the past few months in the parts field has been the obtaining of the exclusive rights for this country of the Hele-Shaw multiple disk clutch by the Merchant & Evans Company, Philadelphia. Powell Evans, of the latter firm, has made considerable study of this clutch, and by making its essential elements out of

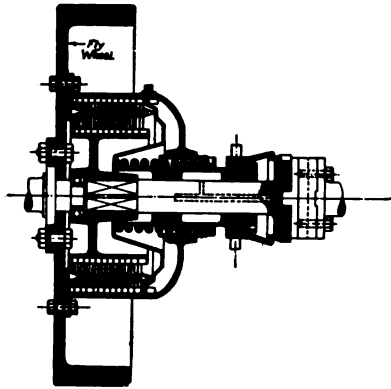

SECTIONAL VIEW OF FLYWHEEL TYPE.

effects a substantial reduction in the cost of production.

The chief difference between the Hele-Shaw and other multiple-disk clutches generally, is that in the former the rings, or disks, are made with V-shaped annular grooves formed by circumferentially corrugating the surface of the disk. The outer edge of one and the inner edge of the other of each pair of disks is notched to engage respectively with the bars or ribs of the outer casing and inner drum. The outer casing is made fast to the driving element, usually the flywheel in the case of an automobile, while the inner drum is attached to the driven shaft. In the larger sizes of these disks, the teeth are reinforced with shoes which offer an increased sliding surface.

The impossibility of obtaining long-continued satisfactory service with old types led to a close study of the problem by Professor H. S. Hele-Shaw, a well-known mechanical engineer, and after considerable investigation and experimenting he hit upon the simple expedient of employing an annular V groove in the disks. But this was not an end of the matter by any means, as exhaustive experiment was required before the proper angle for the groove to give the highest efficiency could be determined. The result of a great number of experiments finally led to the adoption of a 35-degree groove, and showed further that the rate of engagement or "pick-up" of these grooved disks was very uniform. The grooves make a clutch of the same number of disks much more powerful than the same number of flat disks under the same pressure, with a greatly reduced spring pressure to perform the same work, and at the same time no more room is required for disengaging.

Ample evidence of the maker's statement that the Hele-Shaw clutch is designed to be run continuously in a slipping condition without fear of buckling or in any other way injuring the plates, is to be found in the fact that the Brillie 'buses in Paris, on which they are used, operate in practice with two speeds forward, starting and running, the intermediate speeds being obtained by pedal control of the clutch. This is accom-



THE HELE-SHAW AUTO CLUTCH COMPLETE.

plished by distributing the load over all the surfaces in contact, the great number of plates with their thoroughly lubricated wedge area placing but a fraction of the load on each part, which also minimizes the wear. The Hele-Shaw clutch is made for a wide variety of uses, and in addition to a complete line for automobile, motorboat and industrial uses, the Merchant & Evans Company also manufacture the Evans change-speed gear, which is of the multiple direct-drive type combined with the rear axle, the Evans spring motor suspension chassis frame, for cab, touring car or truck use, and employing a straight-line drive requiring no universals, beside a number of other specialties such as the "Star" metal spare tire case, imported axles, and the like.

### THE COMBINATION FAN-FLY WHEEL.

Numerous attempts have been made to combine the fan and flywheel in automobiles, says *The American Machinist*. These experiments have usually taken the form of a spoked flywheel with a number of sheet-metal blades cast in place between the spokes, but, owing to the very intricate pattern and core boxes, and the difficulty in moulding such wheels, their use has not been found practicable. An out-growth of these experiments has taken the form of a flywheel with several spokes—usually five or seven—which are themselves cast in the form of blades. Such flywheels have been found entirely satisfactory in practice, and some manufacturers are using them, thus dispensing with all fan parts proper at the expense of very little added complication to the flywheel. . . . Doubtless the thin sheet-metal blades of a specially designed fan would be more efficient than the thicker and rougher cast blades or spokes in the flywheel. There is another feature to consider. In front of the fan, in the space swept by the revolving blades, a slight vacuum is formed, into which the air is constantly rushing, and being carried through the fan and out of the openings provided for it. Before it is forced out through these openings, it is under a slight pressure. If the fan hub is small enough, there will probably be a space where the linear velocity of the blades, near the hub, would not be sufficient to force air against the slight pressure back of the fan, and the air currents would be reversed. For this reason the space in the flywheel occupied by the large hub would not be very effective were the hub of normal size. . . . Experiments show that for automobile service a 30-degree angle of the blades gives the best results. The edges of the blades should be as sharp as can be cast, with the center about 3-8-inch thick, and should be tied to the rim and hub by generous fillets. The general shape of the balance, and the blades and spokes of the same size and angle, each is made by a core made in the same core box. As this flywheel has seven blades, each core is one-seventh of the circumference, and contains one blade. This blade is made fast to the base of the triangular-shaped core box; the base is easily removable, as the blade parts near the hub. To further insure perfect balance, small bosses or lumps of metal are cast on the inside of the rim, between the spokes; these projections may be chipped as required when the wheel is machined and balanced. As these spokes are necessarily somewhat delicate, trouble is liable to occur through the severe strains set up in them when cooling, and fracture may result. It has been found by experiment that better results are obtained by placing the mould, after it has been poured, into a heated oven, and allowing it to cool gradually.

"In a gas engine there should be no boxes nor unnecessary ports: there must be holes for the valves, but there should be no pockets in the side, the valves all being in the head. In that way there is obtained a cylinder with the minimum surface for the maximum volume."—*Extract from Report Gas Engine Research Com. Inst. Mech. Engrs.*

**THE NEW STOLP SHOCK ELIMINATOR.**

Among the novelties brought forth at the Palace show last fall was one in the shape of a shock absorber that caused the technically wise to shake their heads skeptically when they saw it, and even the explanation of the inventor, Oscar Stolp, of the wire manufacturing house of Shepard & Stolp, of New York, did not suffice to convince them that the most unusual looking device was possessed of the merit claimed for it. Some of the worst doubters were taken out in Mr. Stolp's car fitted with his invention and the manner in which

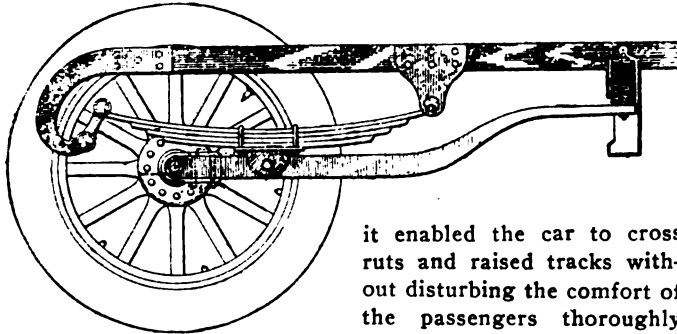

STOLP DEVICE AS APPLIED.

it enabled the car to cross ruts and raised tracks without disturbing the comfort of the passengers thoroughly convinced even the most expert skeptics. But in order to demonstrate beyond any

question the practical value of his invention, Mr. Stolp has had a set of the shock eliminators fitted to one of the Locomobiles in the service of the New York City Fire Department. This car is employed in the Borough of Brooklyn, where there are many rough stretches, and the officials who have occasion to cover them at speeds are loud in their praises of the device.

The accompanying line sketch serves to illustrate both the Stolp shock eliminator itself, as well as the manner of its application. It also shows the relative positions of the connecting parts of the frame and axle, which are claimed by the inventor to be productive of a great increase in resiliency which is not accompanied by a corresponding increase in the rebound transmitted to the body of the vehicle. As will be plain from this sketch, the Stolp shock eliminator consists of a lever revolvably mounted at its after end on the axle of the car, and attached at its other end to the side frame through the medium of a helical spring. Means are also provided for the mounting of the car spring itself at a point on this lever slightly forward of the axle, instead of on the latter, as is the usual practice, from which it will be apparent that the principle of the device is radically different from that of the usual shock absorber in that the object aimed at is not to retard or control the action of the car springs, but to actually absorb the greater part of the shock before it reaches them.

The operation of the device is as follows: When the wheel passes over a depression or elevation, the axle is forced up and the car spring slightly compressed, the forward end of the lever being forced downward against its restraining spring at the same time as the main spring is pivotally attached to the lever, the latter continuing to oscillate slightly until the various members resume their normal positions. From this it will be apparent that the shock transmitted to the wheels and connecting parts, moving either to or from the car frame, will reach them in the form of two opposing forces, respectively applied to the main spring of the car and the auxiliary spring at the forward end of the lever. Since these forces are almost directly opposed to one another, their combined effect on the body of the vehicle is practically nil, as their effect is neutralized. The device is adapted to be attached to the forward wheels of the car in the same manner except that the levers are naturally designed to be placed in a position opposite to that shown. A patent was granted to Mr. Stolp covering it in April, 1907.

**NOVEL REAR AXLE DRIVING UNIT.**

Current engineering practice favors the combination of the gear set with the differential and bevel drive as a unit, and in designing a component of this kind the Standard Roller Bearing Company, Philadelphia, Pa., have embodied in it many features of merit. The housing is unique in that it consists of a single crucible steel casting, all the supports of bearings throughout both the gear set and differential systems being cast integral with it, thus absolutely preventing their disalignment in service. Aluminum is used in the covers to lessen the weight, one being employed over the top of the gear set and the other at the rear of the differential, thus making both very accessible. Three forward speeds are provided, the shafts and pinions being of high-grade chrome-nickel steel running on Standard annular ball bearings. The direct drive is obtained by a dental jaw clutch connection through the propeller shaft and the forward end of the secondary driving shaft, which is supported in the pocketed end of the propeller shaft on a roller bearing, thus insuring permanent alignment of the gear faces. The bevel gears and the master gear are made of high carbon steel having great capacity to resist torsional strains. The differential mechanism is mounted on Standard annular ball bearings, the driving thrust of the master gear being taken by ball thrust bearings on either side of the differential and the driving thrust of the pinion and secondary shaft being taken by a special ball bearing inserted immediately back of the pinion. Both the pinion and master gear are adjustable for wear, so they may readily always run silently. The rear axle driv- ing shaft and torsion tubes are of chrome-nickel steel, the last named being securely fastened

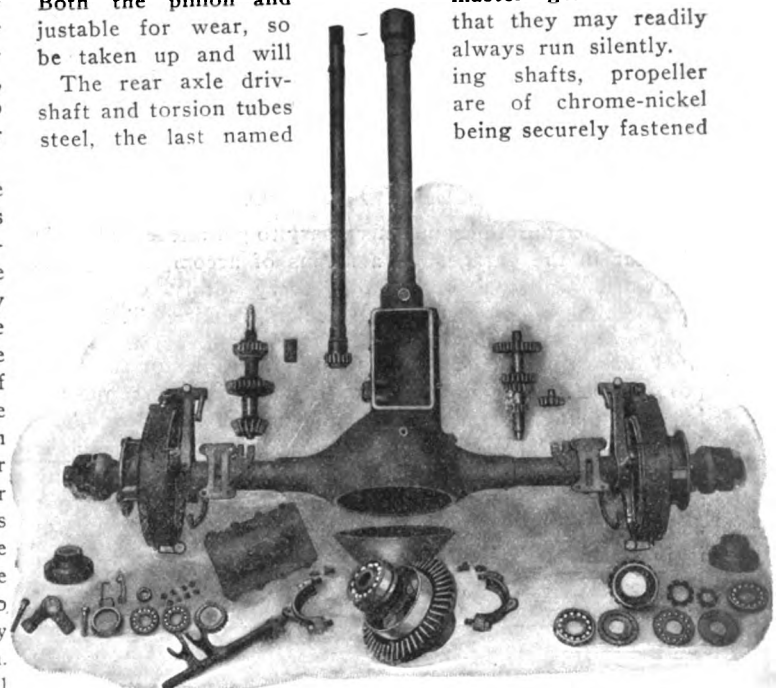

COMPONENTS OF THE STANDARD COMBINED AXLE AND GEAR-SET.

in the forward end of the main housing while it is provided at the upper end of the tube with a steel casting, carrying a ball thrust bearing and an annular ball bearing supporting the propeller shaft. The torsional strains due to stopping and starting, as well as driving, are transferred from the torsion tube directly through a cross member to the frame in a simple and effective manner. The accompanying illustration depicts the various essentials of the Standard rear-axle driving unit, which practically constitutes a complete transmission system minus the clutch, which is usually a part of the motor in reality as now constructed. In this photograph every loose or moving part has been dismounted and is displayed on the background while only the housing remains intact. From the view of the latter the accessibility of the various parts of the gear-set and differential will be apparent. A complete set of brakes is also a noteworthy feature.





MAPLEBAY AIR-COOLED RUNABOUT FROM THE NORTHWEST.]

### A NEWCOMER FROM MINNESOTA.

From Crookston, Minn., has been sent forth a sturdy, speedy looking little runabout which should give a good account of itself, if its strenuous debut proves anything. The Maplebay Manufacturing Company, responsible for the newcomer, declare that it has been tried out under the severe road conditions of the West without any defect being discovered in its make up. A particularly strong feature for an automobile intended for a life on rough roads is its road clearance of 15 1-2 inches, the axles being the lowest part of the car. A four-cylinder Reeves air-cooled engine, developing 22 horsepower, is employed. A friction drive, of the firm's own design, and operated by a single lever, is employed on account of it being one of the simplest and most robust types in existence.

### A HANDY SUBSTITUTE FOR A PIT.

Now and again it becomes necessary to get at the underside of a car in the garage and a means of accomplishing this without a pit is something that every autoist who takes care of his car, and many small dealers, require. T. Neville & Company, Oshkosh, Wis., have just brought out the handy truck, shown in the accompanying photograph, for this purpose. The frame is made of heavy angle iron supported by steel tubing, braced and mounted on double rollers. The bed is made of two-inch planks, so that the whole truck is very substantially made and is designed to withstand any amount of rough usage. Provision for blocking the front and rear wheels of the car so that it cannot run off the bed is in the shape of sets of movable blocks adapted to be fastened to the bed at any point by means of pins, so as to accommodate cars of any wheelbase.

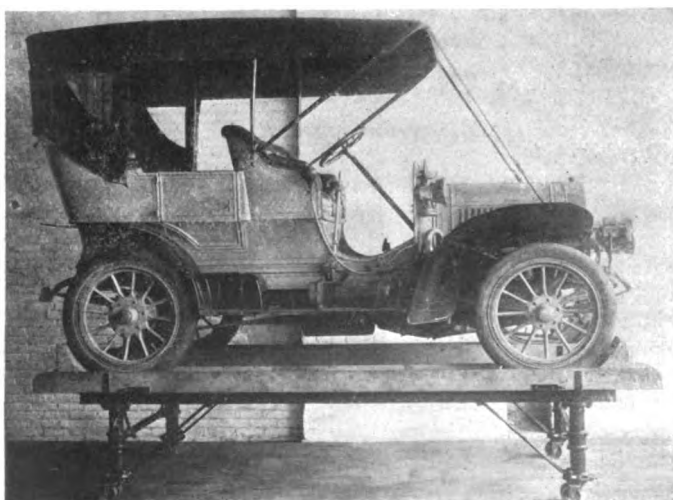

HANDY TRUCK DESIGNED TO REPLACE PITS IN GARAGES.

### AN EFFECTIVE SHOCK ABSORBER EXHIBIT.

That actual demonstration is worth more than all the talk that can be marshalled in favor of the good points of a device has long been recognized by the progressive manufacturer, but it remained for the Truffault-Hartford Suspension Company, 67 Vesey street, New York, to show how this could be done most effectively in the case of a shock absorber exhibited in the confines of a show booth. Two miniature cars were used, one fitted with Truffault-Hartford shock absorbers and the other without. The occupants of the former consisted of a pair of dainty wax dolls, while a rather ludicrous clown doll tried to hold down the other one. A rough road was simulated very effectively by revolving pulleys with bumps on them, the wheels being run at a normal speed. While the car fitted with the shock absorbers staid on the ground with its wheel constantly giving traction, the car without them was in the air half the time and its passengers certainly came in for a jolting. As a climax, one of the springs on the car without the shock absorbers snapped on the last day of the show, thus affording conclusive proof of their value in saving the springs.

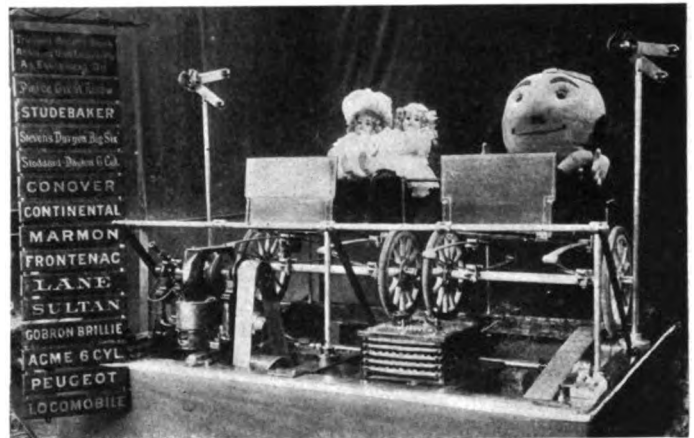

HARTFORD-TRUFFAULT EXHIBIT AT RECENT IMPORTERS' SALON.

### SEVEN CITIES WANT AUTO FIRE ENGINES.

KENOSHA, Wis., Jan. 27.—Seven cities of Southern California are ready to begin negotiations for the purchase of automobile fire engines, now that the two Rambler cars, specially built and equipped with fire-fighting apparatus for the city of Long Beach, have proven efficient.

Long Beach was the first city on the coast to order auto fire engines, and these were designed at the Rambler factory at Kenosha. They have 40-horsepower motors, a speed of thirty miles an hour is possible, and they will carry 800 feet of 2-inch jacketed hose, a 35-gallon copper chemical tank, and 200 feet of 2-inch chemical hose. Space is provided for buckets, hooks, several short ladders, axes, and four men.

In a competitive test between a Rambler car and the old horse-drawn apparatus, made before the order was placed, a short run of 3,880 feet was arranged. Everyone, except the Rambler man, put his money on the horses. The auto was to start with a dead engine. The Rambler won, making the distance in just two minutes flat. Immediately the city officials decided to replace all horse-drawn vehicles with automobiles.

Since the cars were installed the Rambler agent has invented a tilting incline platform on which the car stands level when housed. At the sound of the alarm the driver springs to the seat of the car and drops a hook which releases the chain securing the platform. The platform tips, the car glides down, and the engine starts itself and the race to the fire begins without the loss of a second's time.

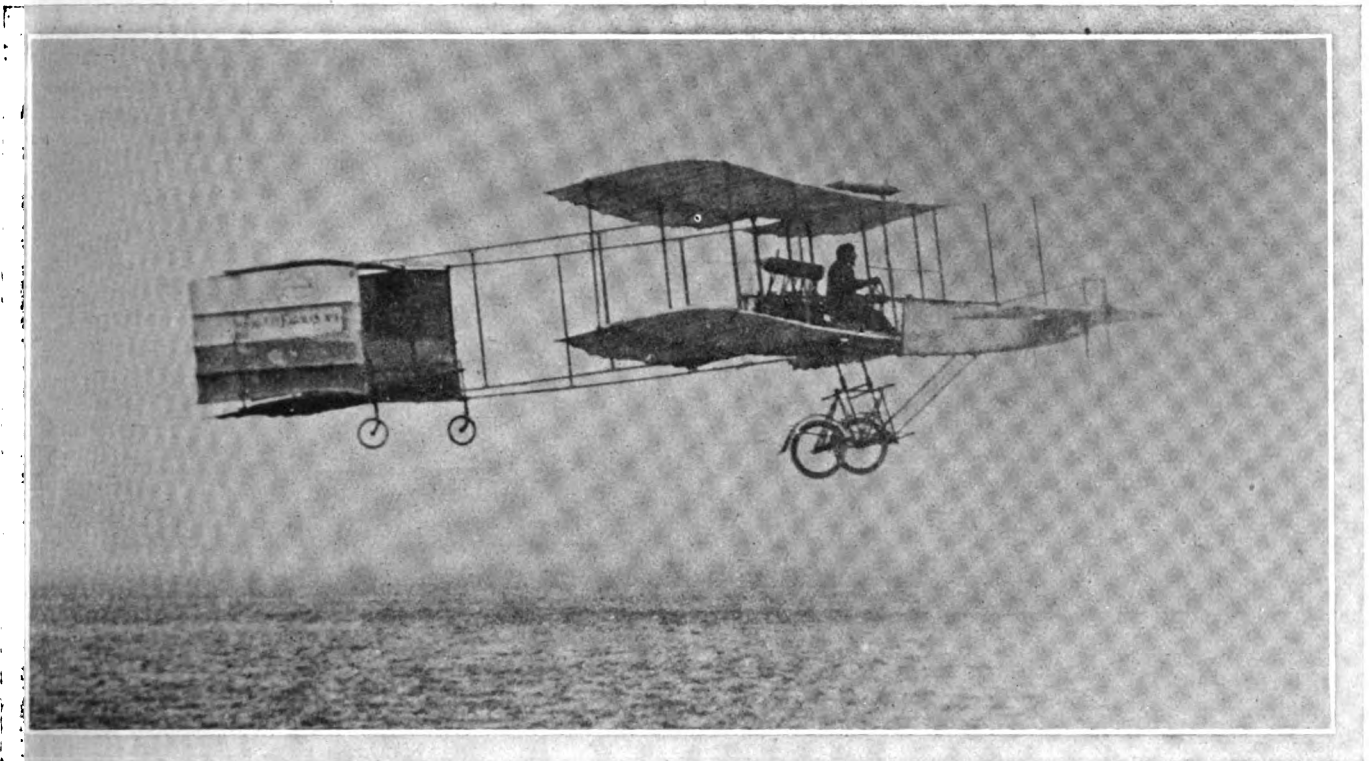

HENRY FARMAN MAKING THE WORLD'S FIRST OFFICIAL FLIGHT OF ONE KILOMETER ON A HEAVIER-THAN-AIR MACHINE.

## FARMAN TELLS HOW HE MADE RECORD FLIGHT

PARIS, Jan. 18.—“I had been training so long and had so much confidence in my machine and my ability to handle it that I was certain of success in my attempt to win the Deutsch-Archdeacon prize. But despite my confidence, there was just a little fear that some trivial accident might occur at the last moment and rob me of victory.

“Luckily everything passed off well; my aeroplane was perfectly stable, the motor roared powerfully and was regulated like a clock, and I knew as soon as I started upwards that success was mine. I took the turn gently, advanced the ignition as I got round, then on the straightaway home retarded the ignition, brought the machine to thirteen feet from the ground, then made straight for the flag. Before I had time to think anything more about it or gather any impressions I had won.”

It was thus that Henry Farman, champion flyer of the world, told his story of winning the Deutsch-Archdeacon prize of \$10,000, when found in his garage an hour after the event which history will recall as one of the most momentous in the struggle of man for aerial supremacy. Farman started up his motor at 10:15 on the morning of January 13, on the Issy-les-Moulineaux ground, outside the walls of Paris. After traveling twelve yards on the ground he rose to a height of thirteen feet and cut the actual starting line at that distance from the ground. An instant later he was veering towards the left and rising at the same time to a height of eighteen feet. Another second and he had swung round the post, the huge artificial bird answering her helm perfectly; another few seconds and the kilometer flight had been accomplished, time, 1 minute 28 seconds. Officially the distance is one kilometer, but as the committee's measurements are merely from the point at which the ma-

chine left the ground to the flagstaff which it succeeded in rounding, Farman should be credited, by reason of the curves which he described, with an actual flight of from 1,500 to 1,800 meters, equal to 1 mile, 140 yards.

Henry Farman, who must now be accorded the honored position of the world's champion flyer, was born in Paris thirty-five years ago. Cycling claimed him as one of its enthusiastic and skilled devotees; riding with his brother Maurice on a tandem, his victories were numerous. Racing automobiles took his attention later, and showed that he was as skilled behind the wheel of a roaring 120-horsepower as on the bicycle saddle. The story is still told in automobile circles of how in the last Gordon Bennett race he took a dangerous turn at 90 miles an hour, having mistaken it for an easier one, and shot over a precipice. The car crashed down several hundred feet, but Farman and his mechanic were caught in the branches of a thick tree. Recovering himself, Farman rolled a cigarette and called to his mechanic, unhurt a yard below, “Say, Jean, have you got a match?”

Farman announces that he will rest for a month while his second machine, on slightly improved lines, is being built by the Voisin Frères. His present aeroplane will also be strengthened and altered in a few particulars, the constant work which it has had to undergo during the last two months having weakened it. After that it is Farman's intention to go to England and compete in all the contests which offer reasonable chances of success.

During the public banquet, at which Henry Farman was presented with a check for 50,000 francs, honor was paid to the Voisin Brothers, builders of the aeroplane, and to Léon Levassor, the designer of the 50-horsepower eight-cylinder motor used on the successful aeroplane.



HENRY FARMAN, CHAMPION FLYER.



Vol. XVIII

Thursday, January 30, 1908

No. 5

THE CLASS JOURNAL COMPANY

Flatiron Building, Madison Square  
New York City

H. M. SWETLAND, President

EDITORIAL DEPARTMENT

A. G. BATCHELDER, Managing Editor  
R. F. KELSEY, Associate Editor C. B. HAYWARD, Engineering-Editor  
W. F. BRADLEY

BUSINESS DEPARTMENT

A. B. SWETLAND, Business Manager  
LOUIS R. SMITH FRANK B. BARNETT  
W. I. RALPH, 1035 Old South Building, Boston, Mass.  
C. H. GURNETT, H. E. WESTERDALE, 836 Monadnock Block, Chicago, Ill.

Cable Address - - - - - Autoland, New York  
Long Distance Telephone - - - - - 300 Gramercy, New York

SUBSCRIPTION RATES:

United States and Mexico - - - - - One Year, \$3.00  
Other Countries in Postal Union, including Canada, - - - - - One Year, 5.00  
To Subscribers—Do not send money by ordinary mail. Remit by Draft,  
Post-Office or Express Money Order, or Register your letter.

FOREIGN SUBSCRIPTION AGENTS:

ENGLAND:—Hilffe & Sons, Limited, 29 Tudor Street, London, E. C.  
FRANCE:—Boyveau & Chevillet, 22 Rue de la Banque, Paris.  
GERMANY:—A. Seydel Mohrenstrasse 9, Berlin.

Copyright, 1907, by The Class Journal Company.  
Entered at New York, N. Y., as second-class matter.

The Automobile is a consolidation of The Automobile (monthly) and the Motor Review (weekly), May, 1902, Dealer and Repairman (monthly), October, 1903, and the Automobile Magazine (monthly), July, 1907.

Copies printed in 1905	- - - - -	730,000
“ “ in 1906	- - - - -	791,000
“ “ in 1907	- - - - -	888,000

ANNOUNCEMENT

The Class Journal Company, owner of "The Automobile," has purchased "Motor Age," published in Chicago, thus signifying unhesitating confidence in the future of the great industry in the interests of which these papers are produced. The combination of facilities will strengthen both publications in a most substantial manner, and these two weeklies—one in the East and the other in the West—will more efficiently reflect and aid the progress of automobiling and allied interests.

**Instability of Design the Greatest American Fault.** In most lines of endeavor that can be compared to that of building automobiles, the man who has achieved success is duly appreciative of the means whereby he gained it and jealously guards the foundation upon which it is built. If he has made a reputation by building a certain type of machine, he does not attempt to enhance it by abandoning that machine and trying his hand at designing another for identically the same purpose. Instead, he carefully adds to the successful fabric already reared, continually refining and improving it in detail, though it always remains the same machine and is always at the head of its class. Just why this should not be equally true of the building of automobiles is an anomaly that has been directly responsible for more than one prominent failure in the past, and its influence is bound to be felt to an increasing extent from now on.

The automobile-buying public may be fickle, but human nature is much the same regardless of what the thing to be bought happens to be. True, there has been a great deal

of slap-dash buying of high-priced cars in which treating has been one of the most prominent inducements, but this is now a thing of the past. The man who buys a car to-day wants to know what its predecessors were capable of doing—in other words, the reputation of its builder for stability of design, and with this fact before one, it is possible to mentally review America's most successful cars, noting that each one is distinguished by this qualification.

What inducement there may be for the successful designer of a car that has made a good name for itself to abandon his work for something new and untried is certainly a mystery, particularly in view of the fact that so many ventures of this kind get as their sole reward the obituary, "he guessed wrong that time," with a consequent shrinkage in the value of the name of the builder. Some makers who appear to be unable to stick to one design for any number of years have achieved for themselves a reputation of being able "to guess wrong every time." Such a policy makes the car doubly difficult to market, a fact that is amply borne out by the relative standing of the most successful cars in the American market to-day.



**Motor Conquest of the Air Practically Accomplished.** The second stage in a series of experiments which will only terminate with the complete conquest by man of the problem of aerial navigation has been reached by the magnificent exploit of Henry Farman, winner of the Deutsch-Archdeacon prize. The initial stage was reached in 1906 when Santos-Dumont first succeeded in flying through space on a machine of the heavier-than-air type. The second has been reached by Farman's performance in starting from a given point, rounding a flagstaff five-eighths of a mile away, and returning to his starting point without touching earth. Expounders of the "jump theory" are silenced, and silenced forever. Farman's flight, in actual distance considerably over a mile in length and occupying one minute twenty-eight seconds, was a victory so remarkable as to leave no possibility of doubt as to the final conquest of the air. If there were room for even a shadow of a doubt it would be expelled by his later performance, when he remained for exactly three minutes aloft.

The part played by the automobile in this titanic struggle is no inconsiderable one. Without the internal combustion engine, created and developed by the automobile, flight would have been a material impossibility. Levasseur, whose name should be coupled with that of Farman, made flight possible by his preliminary work on lightweight motor boat engines, which he lightened, developed and perfected at a time when none but the most optimistic could see any future in the flying machine. There is no denying the fact that the Wright Brothers have lost enormously by the public work of European aeronauts. The brothers from Dayton may have accomplished all they claim, but few authorities will be prepared to pay for whatever they have learned when the results of Farman and others closely following him can be had for nothing.



**An Independent Organization That Is Representative.** Though only entering upon its third year of existence, the Society of Automobile Engineers is an independent engineering body that is already representative of the American industry and is daily becoming more so. A large number of designers of the best-known cars produced in this country are now enrolled in its ranks, and in view of the rate at which its membership list is increasing, there is little doubt that the present year will see the addition of many prominent names. That its members are recruited largely from the ranks of one trade organization or another is evidence of the recognition accorded the need for independent effort.

## MONSTERS AND BABY RACERS BOTH HAVE A GRAND PRIX

PARIS, Jan. 20.—Nine foreign cars, representing Belgium, Germany and Italy, have already been officially entered in the French Grand Prix to be run the first fortnight in July on a circuit now being chosen. Those heading the list are three Germain cars to be handled by Degrais, Roch-Brault, and Perpère; three Benz, with Hemery, Hanriot and Earl as drivers, and the three Fiat with the classic team of last year, namely, Lancia, Nazzaro and Wagner. Indications are that before the list closes there will be between fifty and sixty cars entered for the greatest road race of the 1908 season. In view of such a possibility an elimination race had been spoken of, but the Racing Board has officially announced that none will be held.

Among French firms, Bayard-Clément, Dietrich, Renault, and Panhard have practically completed their teams. The three Renault cars, now well advanced, will be handled by Szisz, Caillois, and Dimitri. Bayard-Clément has signed up with Rigal and Gabriel, and is about to complete arrangements with Hautvast, the crack Belgian driver. Dietrich will have Rougier and Duray, as last year, and will probably fill the place left vacant by Gabriel by the engagement of the Italian Minoia. Demogeot and Cissac will join Heath in the formation of the Panhard team, Demogeot having become available through the decision of Darracq not to race.

### Voiturette Grand Prix Will Unite Single and Two-lungers.

Whatever the number of entries, there will be no elimination for the voiturette race to be run the day before the Grand Prix, and to be known officially as the Voiturette

Grand Prix. In view of the extraordinary success which has attended previous races for single and two-cylinder runabouts of from eight to twelve horsepower, the event to precede the Grand Prix is expected to rival its successor in interest. Speeds were attained in last year's events which astounded even experts, and are a guarantee that on such a circuit as that of Dieppe an exciting contest between the baby racers will be witnessed. Regulations call for a bore of not more than 100 millimeters (3.9 inches) for single cylinder cars, 78 mm. for two cylinders, 68 mm. for three cylinders, and 62 mm. for four cylinders. Taking 4.9 inches as the longest practical stroke with a 3.9 inch bore, this would give an engine of about 15 horsepower on European rating.

Judging from previous experience, one and two-cylinder engines will be in the majority, "fours" not being popular in France for very small powers. Maximum weight for all machines is fixed at 1,322 pounds empty, but with oil in the crankcase and gear boxes. Quick change rims and dismountable rims are not allowed. A racing body, providing two seats side by side, both of which must be occupied, is allowed, mud guards and running boards being optional.

First entries for the Voiturette Grand Prix are three Isotta Fraschini, to be driven by Trucco, Minoia, and Giovanzani. The distance to be covered will be from 250 to 300 miles, racing rules in general being similar to those of the Grand Prix, drivers alone being allowed to change tires, make repairs and fill tanks. Entrance fee has been fixed at \$200 for a single car, \$360 for a team of two, and \$500 for a complete team of three cars.

### NEW HAVEN'S CHIEF OF POLICE CALLS HALT.

NEW HAVEN, CONN., Jan. 27.—Chief of Police Cowles, who was recently installed at the head of the local police department, has announced a campaign against reckless drivers and the use of siren and calliope whistles on autos within the city limits of New Haven. Chief Cowles holds that the sirens come under the ordinance dealing with nuisances and has issued an order warning autoists that their use must be discontinued, at least within the city limits. Many of the Yale college students who own and drive autos in this city have been vying with each other to see who could produce the laudest calliope or siren whistle, until the principal streets sound like the yards of a big railroad terminal.

A petition has been presented to the board of aldermen by automobilists, asking that one day each week, to be known as "auto day," be specified in which autos and other self-propelled vehicles will be allowed in East Rock, West Rock and Fort Wooster parks. These parks, which are the finest and best known natural parks in this section of the country, comprising many acres of beautiful roads and scenery, are at present closed to all motor vehicles, under penalty of a \$20 fine. This action was taken some time ago owing to a number of serious runaways and other accidents which were laid at the door of the autoists.

### NO DEWAR TROPHY RACE AT ORMOND.

There will be no race for the Sir Thomas Dewar trophy at the Ormond-Daytona meet in March, the Contest Committee of the Automobile Club of America having decided to substitute a mile race for a special trophy.

The first entry for the Florida speed carnival has been made by W. Gould Brokaw, who nominated Christie's front-drive racer, built for the French Grand Prix last year. Blakely will be the driver.

### NEXT A. A. A. TOUR UNDER CONSIDERATION.

Conditions for the next annual tour of the American Automobile Association, in competition for the Glidden trophy, were discussed last week, when Chairman Frank B. Hower, of the A. A. A. Touring Board, met S. D. Waldon and Windsor T. White, representing the manufacturers on the A. A. A. Central Conference Committee, and H. O. Smith, of the A. M. C. M. A., who was specially appointed by the N. A. A. M.

One of the routes most favored is said to be a start at Buffalo, west to Cleveland, south to Pittsburg, Hagerstown and Washington, and north to Baltimore, Philadelphia, New York and Boston, with the finish at Bretton Woods, in the White Mountains. The object is to obtain a route that would be difficult and at the same time lead through a district that can be of most benefit to the automobile industry. There are several suggested changes in conditions, and a definite announcement is expected next week.

### THE LATEST BILL AT ALBANY, N. Y.

ALBANY, N. Y., Jan. 27.—Senator McCall introduced a bill to-night amending the motor vehicle law so as to change the speed limit for motor vehicles from one mile in six minutes to one mile in five minutes. This would permit the driving of autos at a rate of twelve miles an hour instead of ten miles an hour, as the law now prescribes in cities, villages and all localities which are built up.

### A. M. C. M. A. ANNUAL, DETROIT, FEB. 8.

In accordance with a vote of the members of the American Motor Car Manufacturers' Association, it has been decided to hold the annual meeting of the association in Detroit, Mich., Saturday, February 8.



## AMONG THE ACTIVE DOERS IN CLUB LIFE

### BAY STATE A. A. TO RUN WASHINGTON'S DAY.

BOSTON, Jan. 27.—The Bay State Automobile Association is to open the 1908 competitive season with an endurance run on Washington's birthday, February 22. The recently-appointed runs and tours committee made this announcement to-day, and it also announced that the run would be 150 miles in length over a triangular course of 50 miles to a leg. The route will be from Boston to Providence, Providence to Worcester, and Worcester to Boston. In selecting this route the committee has had in mind the probable condition of the roads the latter part of February, and it believes that the roads that have been chosen will be the best available at that time of year. They are less likely to be covered with snow and ice than are the highways to the north and east of Boston.

No rules have yet been announced, but the committee has this matter under consideration. The run to Keene last July was so successful and the club received so many compliments upon its conduct of the contest that it is probable that the same rules will be taken as the basis of those governing the coming contest. The committee has in hand, however, the rules of the Chicago and the Philadelphia endurance runs and will make such changes as seem desirable. As the date of the run is only about a fortnight before the opening of the Boston show, when all the dealers will have their new models and when public interest in the new product will be greatest, it is believed that there will be many entries in the run. The committee in charge consists of J. C. Kerrison, chairman; Horace G. Kemp, E. A. Gilmore and Alfred N. Robbins.

### SEASON PLANS OF THE WASHINGTONIANS.

WASHINGTON, D. C., Jan. 27.—President Caverley, of the Automobile Club of Washington, has sent a personal letter to each of the members urging their co-operation in increasing the membership. His letter in part is as follows:

"Some ambitious projects are contemplated during the coming season. A race meet at the Benning race track under the auspices of the club is planned for Decoration Day. A club run to Natural Bridge, Va., via Winchester and Staunton, a distance of some 200 miles over some of the finest roads and through one of the most picturesque sections of the country, is also on the cards. This trip has been taken by several members of the club, who are enthusiastic about the valley of Virginia as a touring ground, where cars, both large and small, find easy traveling. Several short runs to Braddock Heights, Md., Buena Vista Springs, Va., and other interesting points within a radius of 100 miles of Washington, are also in prospect."

### CHICAGO A. C. TO WORK FOR NATIONAL LAW.

CHICAGO, Jan. 27.—The Chicago Automobile Club has voted to give its hearty support to the Legislative Board of the American Automobile Association in the congressional campaign for the Federal registration bill. Sidney S. Gorham and his colleagues on the legislative committee of the club have been instructed to give active assistance to the national body. Illinois motorists in favor of the proposed national registration are urged to write their views to Congressman Sterling, of Bloomington, Ill., who is a member of the judiciary committee of Congress, to which the bill has been referred. The directors tabled a communication asking the club to join a revolt against the present state of affairs in the management of the A. A. A.

### NOTABLE AUTOISTS AT A. C. OF P. BANQUET.

PHILADELPHIA, Jan. 27.—There will be a great gathering of the automobile clans on the occasion of the annual banquet of the Automobile Club of Philadelphia, on Friday evening, February 28. Among those who will probably attend, and have something to say, are Charles T. Terry, chairman of the Legislative Board of the A. A. A.; Colgate Hoyt, president of the Automobile Club of America; John Bancroft, president of the Delaware Automobile Association; Osborne I. Yellott, president of the Maryland State Automobile Association; Robert P. Hooper, of the Pennsylvania Motor Federation and the Automobile Club of Germantown; Cortland F. Bishop, president of the Aero Club of America; Robert B. Caverly, president of the Automobile Club of Washington, D. C., not to mention numerous local and State officials, including Governor Stuart and Mayor Reyburn.

With a membership of about 550 the Automobile Club of Philadelphia was never in such a flourishing condition, and the attendance will, in all probability, be very large.

### LONG ISLAND CLUB TO CONSIDER FEDERAL LAW.

BROOKLYN, N. Y., Jan. 27.—Charles Thaddeus Terry, Chairman of the A. A. A. Legislative Board, will address the members of the Long Island Automobile Club on Friday, January 31, on the Federal Registration bill and the Uniform Motor Vehicle bill drawn up by his board.

By a decision of the board of governors the club has been empowered to secure surety company bail bonds for the use of members, the same to be furnished upon request of any member arrested for alleged violation of the motor vehicle law, the expense thereof being regularly charged to the account of the member securing the use of the bonds.

### PENNSYLVANIA HAS ANOTHER AUTO CLUB.

NEW CASTLE, PA., Jan. 27.—At a meeting last week the Auto Club of Lawrence County put itself on a sound basis and adopted by-laws, rules and regulations for its future guidance. Over a dozen new members joined the club at the meeting, and a strong effort will be made to enlist the co-operation of all automobile owners of the district, a committee being appointed to call on automobilists for this purpose. Arrangements were made for the banquet of the road supervisors of Lawrence county, and the decision formed to hold a meeting first Monday in February for the election of officers. David Jameson is now chairman of the club.

### STRONG RECOGNITION FOR CHICAGO A. A. A.

CHICAGO, Jan. 27.—President L. E. Myers, of the Illinois State Automobile Association, announces the appointment of the chairmen of five of the committees of that association as follows: Signboards, Joseph V. Lawrence, Chicago Motor Club; legislative, Sidney S. Gorham, Chicago Automobile Club; good roads, L. C. Boardman, Chicago Motor Club; membership, Burley B. Ayres, Chicago Motor Club; publicity, C. G. Sinsabaugh. Paul Picard has been made a director of the association.

### RICHMOND COUNTY CLUB ELECTS OFFICERS.

ST. GEORGE, N. Y., Jan. 27.—At the annual meeting of the Richmond County Automobile Club, of St. George, N. Y., Charles A. Schultz was re-elected president. Other officers chosen were vice-president, O. W. Sprigg; secretary, J. J. Worrell; trustee for three years, Dr. J. W. Musgrove.

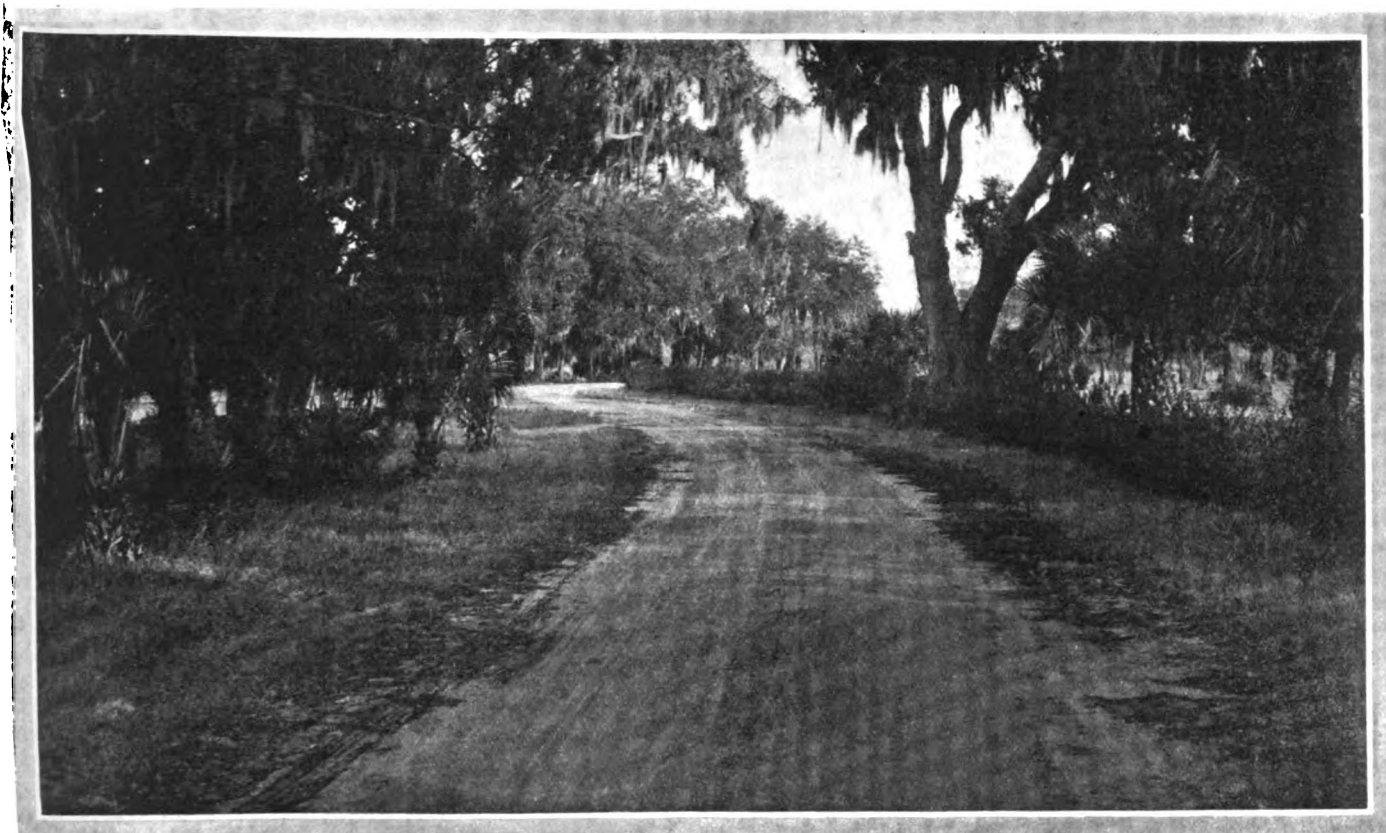

**SAVANNAH COURSE :**

A race for six-cylinder stock chassis will form one of the novel features of the speed tests over the 18-mile course near Savannah, March 18 and 19. The race will not be held unless there are five entries, but in view of the popularity of the six-cylinder runabout, this condition will certainly be met. The trophy will be the Southern Six-cylinder Cup. The six-cylinder contestants will be limited to a cylinder displacement of 575 cubic inches.

Preceding the six-cylinder contest will be a stock runabout race for machines not exceeding 375 cubic inches piston displacement, the trophy to be the Southern Runabout Cup. The big feature of the meet will be the 360-mile speed test for stock chassis not exceeding 575 cubic inches piston displacement, the prize being the Southern Challenge trophy, valued at \$3,000.

Harvey Granger, treasurer of the Savannah Automobile Club Race Committee, on a visit to New

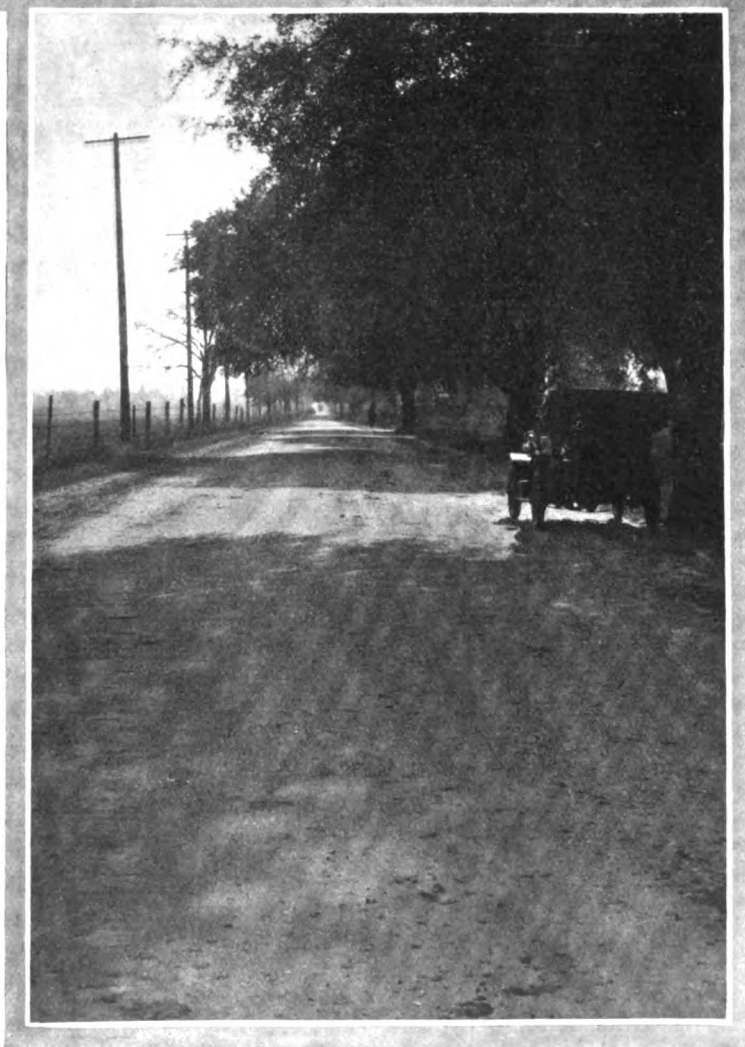

**SCENES ON THE SAVANNAH COURSE, WHERE STOCK CHASSIS RACES WILL BE RUN MARCH 18 AND 19.**

**THREE BIG RACES.**

York to complete arrangements, reports tremendous enthusiasm in the South over the proposed races. The militia companies who will provide an efficient guard over eighteen miles of the finest and most picturesque road to be found in the country, are so enthusiastic over the event that they turned out in full force when a call was made for them to assemble for field telephone practice. The Transportation Committee has succeeded in getting excursion rates on all railroads in Savannah from points 200 miles around, and has promise of a rate of one fare and a third for the round trip from New York. Some of the citizens of Kokomo, Ind., in their enthusiasm to watch the performance of the Apperson Jackrabbit, have chartered a special Pullman car for the trip. The Apperson people state that they will have four cars on the ground early in February; the Premier Company will ship three cars within a week.

## CONCERNING SPEED INDICATORS OF CENTRIFUGAL TYPES

Editor THE AUTOMOBILE:

IN your issue of December 19, 1907, you published an article under the title "Principles of Speed and Distance Recorders," written by Charles B. Hayward, in which appear several statements that are wholly inaccurate and misleading, and one in particular, to which we take exception. On page 912, first column in his description of the centrifugal force type of speedometer, he says:

"It will be evident from this that the faster the spindle turns, corresponding to an increased speed on the part of the car, the greater will be the tendency of the brass ring to take up a position at right angles to its shaft. But, bearing in mind the varying tension or compression of a spring with an increase in its load, the question will naturally arise: How can the instrument be made accurate at all speeds over a range from a few miles an hour up to a mile a minute? In the first place, the dial is calibrated according to the varying control of the spring at different speeds, the divisions accordingly not being uniform over the entire scale."

If Mr. Hayward was thoroughly posted on speedometer construction, or had only examined the dials of the Stewart and American speedometers, he could have seen at a glance that in these instruments at least the dials are equally calibrated their entire length.

Our catalogue also explains this exclusive feature of our speedometers under the heading, "Description of Instruments," from which we quote as follows:

"The Stewart speedometer embraces a device for transmitting the movement of a part, which is centrifugally actuated, and modifying that movement to actuate the indicating pointer proportionate to the change in speed. To cause the angular movement of the index finger to correspond perfectly to the changing speed, variations in the force, caused by the speed of the centrifugal element and variations of the strength of the spring restraining it, must be compensated for. In the Stewart speedometer this is accomplished by interposing a cam between the centrifugal element and the indexing means. The profile of this cam is shaped in the final assembly of each instrument so as to cause the index finger to indicate exactly the speed at which the vehicle is traveling.

In the process of manufacture, each instrument is mounted on a specially devised calibrating machine and all speeds from minimum to maximum are corrected by means of changes in the profile of the previously described cam surface. Once these corrections are made, the instrument is accurate forever—wear sufficient to cause appreciable inaccuracy being negligible."

Again in our catalogue, page 15, under the title, "Scale Is Equally Spaced," we say:

### AKRON TIRE COMPANIES HOLD ELECTIONS.

AKRON, O., Jan. 27.—At the annual meeting of the B. F. Goodrich Company this week, the old board of directors were elected as follows: Col. George T. Perkins, F. H. Mason, B. G. Work, E. C. Shaw, H. R. Raymond, C. C. Goodrich, George W. Crouse. The directors elected officers as follows: President, B. G. Work; first vice-president, F. H. Mason; second vice-president and general sales manager, H. E. Raymond; secretary, C. B. Raymond; assistant treasurer, W. A. Means; general manager of works, E. C. Shaw.

The annual meeting of the Swinehart Clincher Tire & Rubber Company resulted in the election of the following directors: J. A. Swinehart, B. C. Swinehart, W. J. Frank, J. W. Rock, C. O. Baughman and W. H. Rudgers, who chose the following officers: President, J. A. Swinehart; vice-president, B. C. Swinehart; secretary and treasurer, C. O. Baughman. According to the report of the president, the past year has been a prosperous one, and in support of his statement he stated that in the year 1904 the output of the company was 2,527 tires, while at present the company has out and in use over 20,000 tires. Mr. Swinehart stated that the increased business was largely due to the more favorable attitude of garage men. The company will establish branch houses in Philadelphia and St. Louis soon.

"The evenly spaced scale is evidence of a principle properly applied. The difficulties that makers formerly contended with and endeavored to correct by using an unequal scale, we correct in the mechanism of the instrument itself, which feature is fully covered by patents.

"The unequal scale is not only a disfigurement, but tends to deceive the eye. There is also a tendency to doubt the accuracy of an instrument that will measure the first ten miles in inches and the last twenty miles in a space so small as to be read with difficulty. Observe the ease with which the Stewart dial may be read."

Mr. Hayward also states that the extreme of simplicity is not secured in the centrifugal type and in another type, which he describes, claims it to be competent of a degree of accuracy unattainable in other fields, from which the reader must infer that the centrifugal force type is of complicated construction and inaccurate. Inasmuch as he has erred regarding equal calibration of the centrifugal type, it is evident he is not acquainted with the construction of Stewart or American speedometers and may have qualified his statement as regards simplicity and accuracy had he been familiar with these instruments. When an instrument is absolutely accurate, it leaves nothing to be desired in the degrees of accuracy, and as our patented cam (as explained) permits of adjustments that secure indisputable accuracy, it is difficult to distinguish the degree of accuracy he credits to this other type as not attainable in ours.

We take exception to Mr. Hayward's statements because it is due to the many thousands who are using Stewart and American speedometers to know that the failings he ascribes to the centrifugal force type of speed indicator do not apply to ours. After all is said, a theoretical discussion of the relative merits of different types counts for nothing as against what the same instruments will do in actual service. It is the tried and proven that must be recognized as against the unproven. We want to say for the benefit of those car owners who may be at a loss to know which type to purchase that they test for themselves the different types and we will gladly at all times furnish either of our instruments to be put on the car in competition with any other on the market and abide by the result.

STEWART & CLARK MANUFACTURING COMPANY.

CHICAGO, Jan. 27, 1908.

### RETAIL DEALERS WILL FORM AN ASSOCIATION.

A movement is on foot for the enrolling of the 2,000 retail automobile dealers of the United States into a national organization, to be known as the Association of Automobile Dealers of America. It is declared that the dealers, who last year sold 50,000 cars at a valuation of nearly \$100,000,000, could, by co-operation, bring about many much needed reforms in transportation charges, improve the second-hand car business, keep records of salesmen, mechanics and chauffeurs, and do much to remedy unbusinesslike methods. Charles A. Wardle, who has for some years been connected with the A. L. A. M., will be manager of the association.

### GROUT FACTORY NOW IN NEW HANDS.

ORANGE, MASS., Jan. 27.—The entire plant of the Grout Bros. Automobile Company in Orange has been sold to Wm. L. Grout, the millionaire sewing-machine manufacturer, of Greenfield, Mass.—the Grout Bros. having completely withdrawn from the business. The future active management will be in the hands of well known automobile men, and the plant will be run upon a larger scale than ever before. The latest model embraces all of the latest and best features in automobile construction.



AFTER THE BIG SNOW IN WISCONSIN PURCHASERS OF RAMBLERS WERE GIVEN DEMONSTRATIONS NEAR THE KENOSHA FACTORY.

#### MR. BRISCOE'S WESTERN OBSERVATIONS.

THAT the recent financial crisis was only a rich man's panic is the belief of Benjamin Briscoe, chairman of the Committee of Management of the American Motor Car Manufacturers' Association, who has just returned from a two weeks' Western trip. In speaking of his trip Mr. Briscoe said:

"There is no question in my mind that the recent crisis in Wall Street was merely a rich man's panic, brought on by certain conditions which I believe can be blamed to a group of financial pirates who have been plunging heavily and recklessly; many of them using the people's money. I have come to this conclusion after thoroughly studying the situation and after lengthy talks with prominent Western banking and manufacturing interests. The West was never in a more healthy and flourishing condition. The crops are heavier than at any time in the history of the country."

#### COLONEL CLIFTON ON THE OUTLOOK.

BUFFALO, N. Y., Jan. 27.—The recent financial troubles which were felt throughout the country did not materially affect the working forces of the George N. Pierce Company and the E. R. Thomas Company, of this city. Col. Charles Clifton, of the Pierce Company, said:

"The future of the automobile industry does not hinge upon the present financial conditions. The fact seems to be that every line of industry suffers from the stagnation, and the automobile makers are seemingly but waiting for the revival which is not far off. I have learned that other industries have even cut their helping force in half. This is not true in automobile circles, for to-day we are employing nearly our entire force and turning out more cars than last year."

The word from the Thomas factory is that the great demand is for their highest priced car, the big six-cylinder Flyer.



A TOUCH OF REAL WINTER IN CENTRAL PARK, NEW YORK CITY, AND THE PACKARD DOING DUTY AS A SNOW PLOW



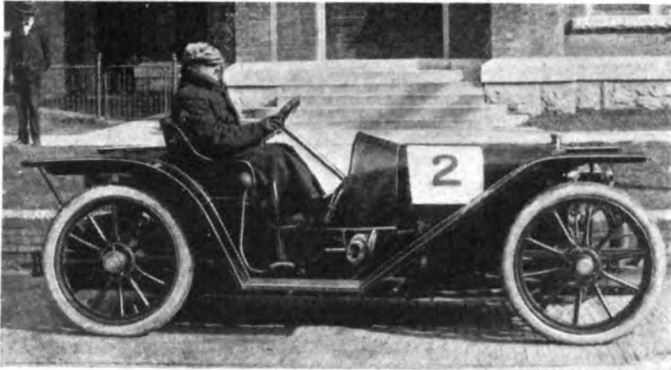

AMERICAN ROADSTER THAT MADE FASTEST TIME AT HOUSTON.

### ENDURANCE RUN OF HOUSTON'S AUTO CLUB.

HOUSTON, TEX., Jan. 27.—Weather conditions that were favorable ushered in the day set for the endurance run of the Houston Automobile Club, on January 12, and fifteen cars participated. A most successful run it promised to be, but several accidents, one in which one of the cars collided with a street car resulted fatally, resulted in the run being officially called off by the officials. All of the cars, with the exception of three, finished with perfect scores, however, and the best time of the day was made by the American Roadster, driven by E. A. Sontag, who covered a distance of five miles on the straightaway shell road between Cypress and Houston, at the rate of seventy miles an hour. The endurance test was not to be a race, but local rivalry between car owners and dealers made the run decidedly interesting from a speed standpoint. The following cars finished with unofficial perfect scores:

American Roadster, 40-horsepower, driven by E. A. Sontag, for Empire State Motor Company.  
 Frayer-Miller, 50-horsepower, owned and driven by W. T. McCallip.  
 Buick, 22-horsepower, owned and driven by Max Stubenrauch.  
 Dixie-Flyer, 28-horsepower, driven by Mr. Ayres, for Southern Motor Company.  
 Ford, 20-horsepower, driven by Van Curtis, for Wade Cox.  
 Frayer-Miller, 50-horsepower, driven by W. C. Monroe, for Barden Electric and Machinery Company.  
 Wayne, 30-horsepower, owned and driven by Edward F. Marone.  
 Overland, 20-horsepower, owned and driven by John Patrick.  
 Ford, 40-horsepower, driven by Wade Cox, for H. T. D. Wilson.  
 Maxwell, 14-horsepower, owned and driven by R. W. Alken.  
 Thomas, 40-horsepower, owned and driven by J. K. Foley.  
 Ford, 15-horsepower, owned and driven by R. R. Ratcliff.

The Houston Automobile Club now has a membership of 60 and is rapidly gaining in local influence. An appropriation of \$500,000 is to be spent on the roads of the county, and the club has had much to do with securing this handsome sum for road improvement. Harris county now has 200 automobiles, the largest number of any county in Texas.



DIXIE FLYER THAT FINISHED WITH A PERFECT SCORE.

### OWEN STARTS ON SECOND "MUDLARK" TRIP.

ALBANY, N. Y., Jan. 27.—Equipped with a formidable array of shovels, picks, ropes and tackle for emergency work, Ralph Owen, in a 40-horsepower Oldsmobile, arrived here to-night on a pathfinding trip from New York to New Orleans. The object of the trip is three-fold. The first being the gathering of data relative to the roads between New York and the metropolis of the gulf; the second to gather data relative to the political situation, and the third it is expected that the car which Mr. Owen is driving, at the completion of its trip, will be used as the official car at the Mardi Gras celebration beginning the end of February.

From Cleveland to Louisville, Birmingham and New Orleans, Mr. Owen will attempt to find the shortest and best roads. The information and route will be published in pamphlet form for the benefit of the motoring public.

At Cleveland F. L. Smith will join the party, and from then on will make a canvass of the towns through which they pass relative to the political situation, endeavoring as far as possible to get the strength of the various presidential candidates. The information thus gained will be given to the newspapers and to the national political committees.



RALPH OWEN IN HIS OLDSMOBILE READY FOR THE START.

### JANUARY AUTOMOBILE TRADE DIRECTORY.

Three hundred and four pages comprise the January issue of the "Automobile Trade Directory," published quarterly by the Class Journal Company, Flatiron Building, New York. The Directory, which covers not only the entire automobile industry of the United States, but includes every industry which in any way contributes to the production, operation or care of horseless vehicles, is classified in the simplest and most efficient manner. An idea of the extent of the ground covered is obtained from the fact that the index to classifications alone calls for more than 1,400 headings. Manufacturers in each branch of the automobile industry are classified under the heading of the goods they produce, there being sufficient divisions in all the branches of the trade to make the reference as simple as possible. Thus under the heading tubing, are separate divisions for makers of brass and copper tubing, flexible metallic tubing, soft rubber tubing, hard rubber tubing, and steel tubing. This system is pursued throughout the entire industry. The compilers claim that the lists are brought up to date with each issue, that every firm is included, and that all the firms are producing the articles under which they are classified. A series of tables and data for engineers form a valuable addition for reference purposes.

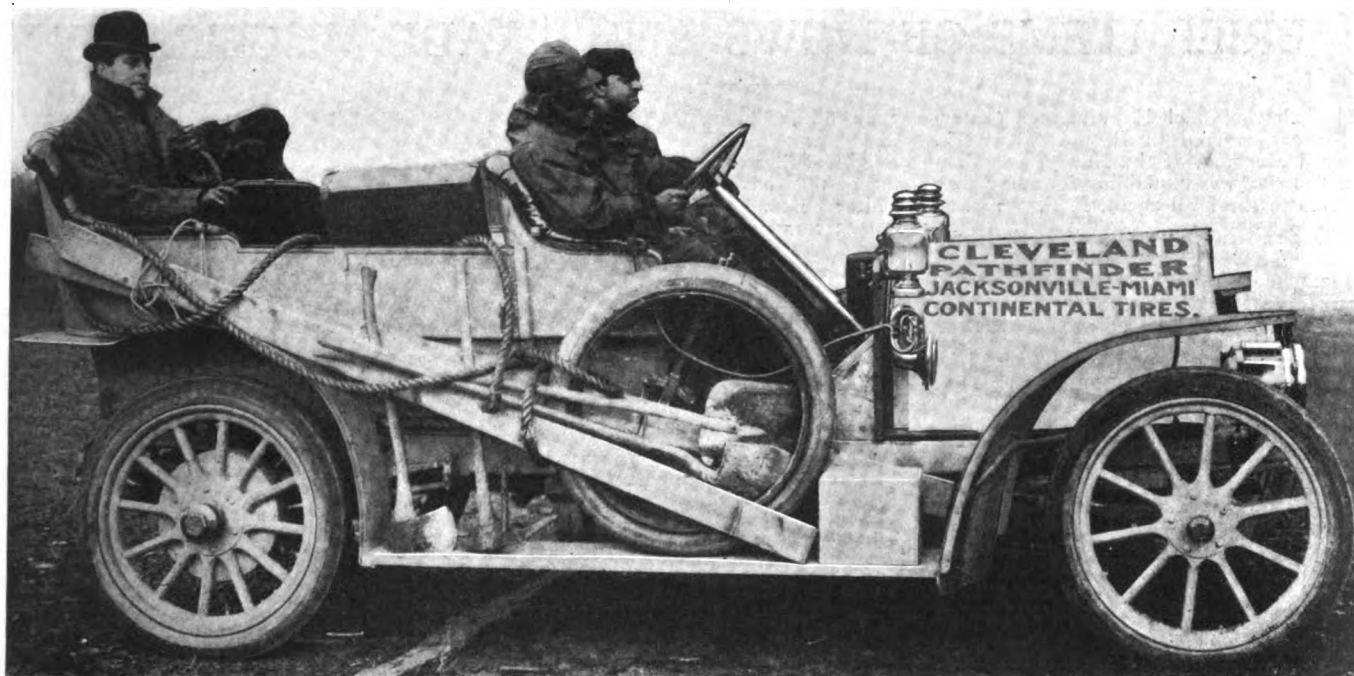

CLEVELAND PATHFINDER, FULLY EQUIPPED FOR THE PIONEER RUN FROM JACKSONVILLE TO MIAMI, FLA.

#### ORMOND PATHFINDER REPORTS PROGRESS.

Official Pathfinder Cleveland, forerunner of the batch of tourists who will make the trip from Jacksonville to Miami, Florida, reports a complete string of signposts in its wake as far as Ormond.

The big Cleveland touring car, with James Laughlin, 3d, at the wheel; George E. Sebring, of Daytona; Walter S. Drennen, and Photographer Spooner, in the tonneau, and a pioneer outfit on the running board, started from Jacksonville on January 23, and reached St. Augustine the same evening. It had been intended to make Ormond that night, but owing to several departures from the right track for the purpose of verifying the cross roads and placing signs, much time was lost. Though the finding of the path the first day out was a comparatively easy matter, the party managed to get lost twice. Roads consisted, for the most part, of a hard and sometimes rough path through the scrub palmetto, and the only scenery was the same scrub and the high pine trees cut and bucketed by the turpentine men. Six fords had to be passed through, but they were all of hard bottom.

Partly because the shades of night were overtaking them fast and partly because a raging forest fire overtook them seventeen miles from Ormond, the Cleveland pathfinder had to be pushed to its utmost at the close of the second day out. The fire was an unrehearsed thriller which loomed up one hundred yards away when the car had just passed over the second automobile bridge erected by Thomas White, of Cleveland. After a second's hesitation it was decided to rush the machine along the edge of the forest conflagration. It was an exciting moment, for the flames rose to a height of ten to fifteen feet, and threatened to reach the automobile. A wild cat rushed yelling before the flames, then a dense wood with thick overhanging foliage was plunged into and the car pulled up finally at Ormond, having covered a distance of 84.9 miles for the day. There was a stretch on the fine shell road outside St. Augustine where a speed of 55 miles an hour could be maintained, but the average going through turpentine camps and stills was of a much more modest nature. Though there will be some rough riding, there will be no difficulty in finding the trail, for the Cleveland pioneer has placarded every spot.

#### S. A. E. BECOMING MORE REPRESENTATIVE.

That the need for independent engineering investigation wholly free from any trade affiliations is generally recognized is evident from the manner in which the membership of the Society of Automobile Engineers is rapidly increasing. Though only entering upon its third year of existence, it already includes in its ranks a large percentage of the designers of the most prominent cars built in this country.

Among them are Russell Huff, engineer of the Packard Company; David Fergusson, designer of the Pierce cars; A. L. Riker, designer of the Locomobile; Harold B. Anderson, chief engineer of the Winton Company; Henry Ford, head of the Ford Motor Company, and designer of all the Ford cars; B. D. Gray, chief engineer of the American Locomotive Automobile Company, builders of the Berliet; J. G. Perrin, designer of the Lozier; W. A. Wall, of the National Motor Vehicle Company; Alanson P. Brush, former designer of the Cadillac, and more recently of the Brush runabout; Hiram P. Maxim, late chief engineer of the Electric Vehicle Company, and designer of the Columbia gasoline and electric cars, and who is now building a line of new electrics; John Wilkinson, designer of the Franklin cars; Harry A. Knox, president of the Atlas Motor Car Company; Thomas J. Fay, who was responsible for the first Simplex cars and later designed the Ellsworth; Walter C. Baker, formerly of the Baker Motor Vehicle Company; Henry Souther, consulting engineer and metallurgist of the Association of Licensed Automobile Manufacturers; C. R. Greuter, designer of the Matheson cars; C. T. Jefferys, of the well known firm that builds the Rambler cars; Howard E. Coffin, of the Thomas Detroit factory; E. T. Birdsall, designer of the new Selder cars; F. B. Stearns, head of the company of the same name building the Stearns cars; Joseph Tracy, the well-known racing driver and consulting engineer; Charles E. Duryea, consulting engineer of the American Motor Car Manufacturers' Association; Herman F. Cuntz, the leading technical spirit of the Licensed Association and a number of others prominent in the automobile world. It is the intention of its founders that it should be representative of the industry as a whole, and to accomplish this end it is open to manufacturers of accessories and their authorized technical assistants, who are admitted to associate membership.

## BRIEF ITEMS OF NEWS AND TRADE MISCELLANY

The first Model H Marmon water-cooled car arrived in Boston last week. Howard Marmon, of the Nordyke & Marmon Company, is explaining its many new features to the local agent, F. E. Wing.

Two licenses were revoked by the Massachusetts Highway Commission last week, and among the large number of new licenses granted was one to an 11-year-old son of a prominent Boston auto dealer.

Its plant having been badly damaged by fire, the Delaware Auto Storage and Repair Company, of Wilmington, Del., has gone into the hands of a receiver, Christopher L. Ward being named as such by the Court of Chancery.

The Brown Auto Top Company, of Philadelphia, has inaugurated a new deal by establishing a general automobile repair shop at the Belmont avenue entrance to Fairmount Park. The new shop will be run in connection with the Belmont Garage.

Registrations in the State of New York, on Thursday, January 23, reached the 50,000 mark, license number 50,000 having been issued to the Lozier Motor Company. This number will be carried by the Lozier demonstrating cars during the 1908 season.

Though it was only incorporated in 1904, the London Auto Supply Company, 1229 Michigan avenue, Chicago, makers of the London auto tops, Lasco folding glass fronts and windshields, has found it necessary to increase its manufacturing facilities and obtain more room on several occasions. Due to the general satisfaction given by their tops and glass fronts, their sales were more than doubled during the past season. An attractively illustrated catalogue showing the entire line has just been issued.

In connection with their electric pleasure and commercial cars, the Studebaker Automobile Company, South Bend, Ind., are now marketing mercury arc rectifiers to transform alternating current, as commonly employed for lighting and power purposes, to direct current, in order that it may be utilized for charging batteries. The introduction of the rectifier is claimed to reduce the already low cost of operation of the electric more than one-half, so that where the expense of charging a two-passenger electric vehicle has formerly averaged \$25 to \$30 a month, it should not now exceed \$8 to \$10 a month.

The factory of the Wayne Automobile Company, in Detroit, is one of the number that has not been completely shut down at any time during the recent financial disturbance and preparations are now being made to resume with a full force in a very short time. Further evidence of the fact that these builders have not been disconcerted in the least is to be found in the fact that they are now going ahead with the construction of a large testing course adjacent to the works in Piquette street, Detroit. When the property was acquired some years ago, a large piece of land was left vacant for this purpose, but it was not until the present year that the company cared to go to the expense of building the track.

The effect of ball-bearings on the efficiency of a car is immediately apparent in its ton-mile capacity per gallon of fuel, and the Hess-Bright Manufacturing Com-

pany, Philadelphia, Pa., calls attention to the showing of cars equipped with Hess-Bright ball-bearings as compared with those not having this advantage. The Chicago Economy test of last fall brought out 23 cars of 18 different makes, the distance being 95 miles. The winning car, which averaged 45.4 ton-miles per gallon, was equipped with "HB" bearings, as were also 12 cars of 7 different makes which averaged 32.7 ton-miles per gallon, as against 28.3 ton-miles for the remainder. The cars that scored second and third were also thus equipped.

Suit has been entered by Hopewell Brothers, of Cambridge, Mass., through their patent attorneys, Crosby & Gregory, against the Boston branch of the Post & Lester Company, of Hartford, Conn., for selling the Perfect tire case manufactured by W. H. Wiley & Son, of Hartford, and which is alleged to be a direct infringement of their patent. The recent action brought against the Auto Supply Company, of Boston, agents for the Allen tire case, has been discontinued, a satisfactory settlement having been reached. The Allen Auto Specialty Company, of New York, will henceforth handle the Hopewell Brothers' fabric line in its entirety in the States of New York, New Jersey and Pennsylvania.

As the result of the "Continental canvass" made by General Manager J. M. Gilbert, of the Continental Caoutchouc Company, he has found that things are not half as bad as they seem to some people. "Automobiling as a sport is in a pretty lively condition as yet," said Mr. Gilbert when seen at the Continental headquarters, at 43 Warren street, New York City. "There is plenty of vitality in the industry and the demand for new cars goes to show that there are a good many people who have ready cash and who are willing to spend it for what they want." Mr. Gilbert's canvass was not of the haphazard or hearsay order, inquiries being made throughout the country and the results carefully tabulated, the manufacturing establishments in Detroit, Cleveland, Buffalo, Chicago, Indianapolis and other cities being well covered. Many of the plants that were shut down entirely are now running full time and many others are making preparations to resume shortly.

### NEW AGENCIES ESTABLISHED.

Jacobs & Bartlett have opened their new salesrooms at 887 Boylston street, Boston, and will represent the Allen-Kingston cars in Boston and vicinity.

A motorcycle store, devoted to motorcycles only, has been opened by the American Motor Company, 218 Clarendon street, Boston, where the M. M. motorcycles will be carried exclusively.

The Glide car will be handled in St. Louis and western Missouri during the present year by the Weber Implement Company, 415 West Main street, St. Louis. The Dupree Commission Company, Waco, Texas, will handle the Glide in central Texas territory.

J. D. Lee, Jr., local manager of the Girard Motor Car Company, of Philadelphia, has just secured the agency for the Fiat for Eastern Pennsylvania. Allen Dalley was the former local representative. The

Girard Company already handles the Cleveland and the American Mors.

C. A. Benjamin, of the Aerocar Motor Company, of Detroit, has been taking a whirl through some of the Eastern States during the past ten days closing contracts for agencies for 1908, and reports the following connections to handle the Aerocar line: The George H. Lowe Company, Boston; G. M. Drake, Huntington, L. I.; George A. Bauer, Rochester, N. Y.; Maxwell Auto Company, Erie, Pa.

Arrangements have been completed by Paul Lacroix for direct Renault representation at 1549 Michigan avenue, Chicago. The Western house, which will be in charge of C. T. Ziegler, will be a branch of the Renault Frères Selling Branch at New York, and, like the metropolitan establishment, will carry all models, be completely supplied with spare parts, and equipped for repair work. An expert mechanic is being sent from the Billancourt factory to take charge of this department. Philadelphia and Eastern Pennsylvania will be supplied with Renault cars by Prescott Adamson, located at Broad and Spring Garden streets, this agency, now handling Columbia gasoline and electric cars, having closed contracts for the representation of the popular French marque.

### RECENT TRADE REMOVALS.

The Boston Auto Light Company, formerly located in the Motor Mart, that city, has moved into a larger salesroom, more centrally located, at 751 Boylston street.

The local G. & J. tire agency, at 711 North Broad street, Philadelphia, will move to much larger quarters next door, at No. 713, about March 1. The new building is 30 by 140 feet in dimensions, and will afford ample accommodations for the rapidly growing business of the agency.

The Cameron Motor Car Company, of Brockton, Mass., has purchased the building and equipment of the Beverley Manufacturing Company, at Beverley, Mass., which was formerly devoted to the Upton transmission gears. This plant will be run in connection with their present works at Brockton. The main offices of the company will be at the Beverley plant.

The Palmer & Singer Manufacturing Company are now installed in their new quarters, at 1620, 1622 and 1624 Broadway, from which address the Simplex, the Isotta-Fraschini and the three lines of Palmer & Singer cars will be marketed. Four floors of the building are devoted to the garage, which has a capacity of 150 cars, making it one of the largest on Broadway. Owing to its convenient situation, it has sprung into immediate popularity with the residents of the Circle district.

### PERSONAL TRADE MENTION.

P. O. Sheehan, well-known throughout the bicycle and automobile trade, resigned last week as sales manager of the Old Colony Light Company, of Boston, makers of the Puritan gas tanks.

J. S. Draper, of the Wayne Automobile Company, is the guest of the Boston representatives of the Wayne, the Morrison-Price Company. Mr. Draper reports that business is steadily improving in the East.

**INFORMATION FOR AUTO USERS**

**Stitch-in-Time Vulcanizers.**—The prolongation of the life of an automobile tire is assured by attention to the use of a vulcanizer whenever defects reveal themselves. Three distinct models of these instruments, now extensively used by automobilists, are manufactured by the Stitch-in-Time Vulcanizer Company, Topeka, Kansas. The latest of the trio is the "Stitch Nine" vulcanizer, specially

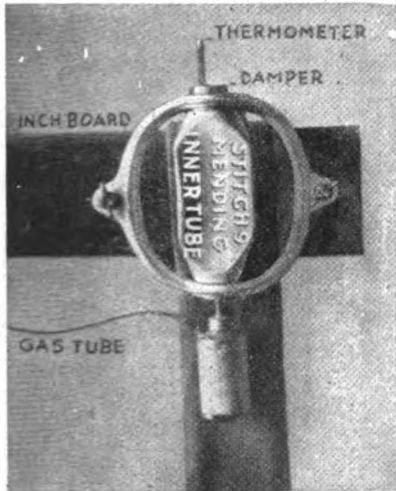

THE NEW "STITCH NINE" VULCANIZER.

designed to fit flat tread tires, and for mending inner tubes. Its special features are that it can be heated by either gas or gasoline without changing burners, will fit any tire from the smallest to the largest, in both circumference and diameter, and has a swivel yoke admitting of the faces of the vulcanizer adjusting themselves to equal pressure at every point of contact. The "Stitch Nine," which is made of aluminum and weighs only three pounds, will vulcanize either on the tread or side close up to the rim. The two other instruments are the "Pig" vulcanizer, which will take a patch from 9 to 10 inches long the full oval of the tire, to 1 1/2 inches of the rim, and the "Stitch-in-Time" vulcanizer for smaller repairs.

**Dover Safety Waste Cans.**—The rules of the Board of Fire Underwriters call for the placing of all oily waste and rags in a metal receptacle with a cover of the same material, as such substances are apt



DOVER WASTE CAN WITH SPRING COVER.

to take fire spontaneously. To meet these requirements, the Dover Stamping & Manufacturing Company, 385 Putnam avenue, Cambridge, Mass., are putting on the market a can of this type which is provided with a recently-invented self-closing cover. The device is extremely simple and durable, beside being positive in action, so that

the cover is always kept tightly closed. The can itself is of heavy, durable construction. By a new method of construction exclusive with these makers, no solder is used in the construction of the can. The material consists of black steel sheets, galvanized after making, so that they will stand the hottest fire without falling apart. They are made in six sizes, ranging from 12 by 15 inches up to 24 by 38 1/2 inches, and have been especially designed for garage and factory use. The illustration gives an idea of the general appearance of the complete can, as well as that of the self-closing cover.

**Half-Nelson Emergency Tires.**—Running on a flat tire means the price of a new shoe as well as a new tube, while any distance on the rim entails the expense of a replacement there, so that it certainly does not pay to be caught far from home or a repair shop without some means of protecting the wheel and rim. Realizing this, the Half-Nelson Tire Company, 1917

Portland street, Minneapolis, Minn., have brought out a patented emergency tire of this name which will pay for itself by the aid rendered in a single case of emergency. The Half-Nelson emergency tire consists of a number of independent sections with a double hook and eye device that cannot possibly pull apart, the last joint which is tightened up when the tire is in place on the wheel being made with a right and left-handed screw. The details of the two forms of joints are shown in the accompanying illustration.

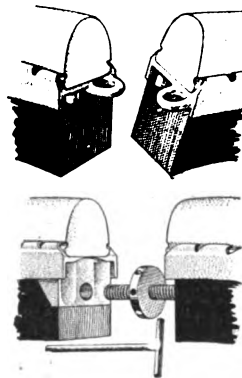

METHODS OF FASTENING HALF-NELSON TIRE.

**Pence Limousine Heater.**—The necessity for heating the interior of a closed car during winter is evident, while the problem entailed would appear to be of the simplest nature, as many times the amount of heat required is being wasted through the muffler every minute the motor is running. But not every attempt at accomplishing this has proved successful by any means, many having the disadvantage of introducing the burnt gases from the cylinder directly into the car, making the heat a cause of annoyance rather than a comfort. To overcome this, the Pence Automobile Company, 717-719 Hennepin avenue, Minneapolis, Minn., has

recently perfected an improved type of heater for this purpose. As shown by the accompanying illustration, it consists of a special jacket for the muffler with an inlet for pure cold air at the bottom forward, and an outlet for the heated air connected with a register placed flush with the floor of the car. Only pure air is warmed and introduced.

**A Speed and Distance Recorder.**—The latest development in the line of speed indicators is the Velograph, produced by Velograph, Limited, of Berlin, and sold in America by the National Sales Corpora-

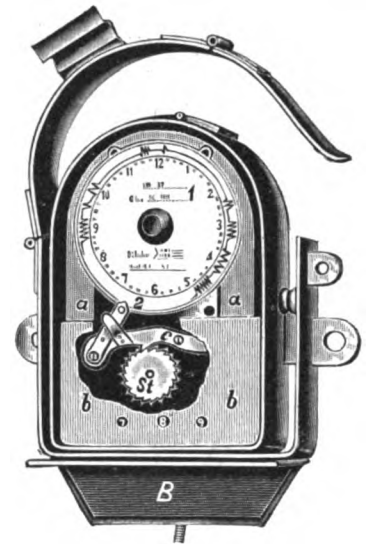

VELOGRAPH, SHOWING THE INTERIOR.

tion, of 296 Broadway, New York. Total distance covered, speed at every portion of the journey, and all stops are permanently recorded on a circular disc in the instrument, thus giving a complete record of the movements of the vehicle, which is especially valuable for commercial automobiles. The Velograph is wound up like a clock at the commencement of the day's work. A circular disc divided into hours and minutes is driven by the clockwork, while a pointer carrying a pencil and operated by a flexible cable from a road wheel makes a continuous record around the outside edge of the disc. Simultaneously with the up-and-down movement of the pointer, the disc revolves around its center, a zig-zag line being traced, the more acute the angle of the zig-zag the quicker the speed, and vice versa. The instrument is used very extensively in Germany by the postal authorities and important business houses.

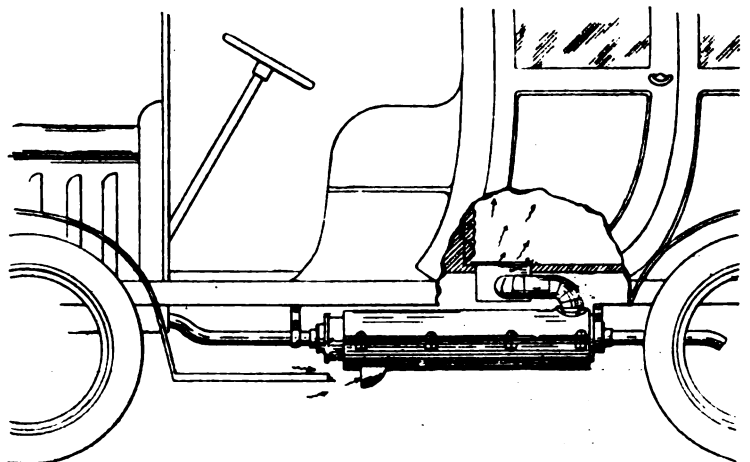

HOW THE PENCE HEATER IS APPLIED AND USED.



**INDEX  
TO ADVERTISERS**

Acetylene Gas Illuminating Co. 47	Crown Soap Co. 68	K. W. Ignition Co. 49	Pierce Engine Co. 54
Acme Motor Car Co. 54	Cullman Wheel Co. 57	Kellom Co., Chas. F. 57	Pioneer Brass Works. 51
Adams Co. 54	Cummer Co., Jos. W. 68	Kent Mfg. Works. 49	Pirelli & Co. 56
Add-Wear Auto Tire Sleeve Co. 55	De Luxe Motor Car Co. 54	Kimball Tire Case Co. 61	Pittsfield Spark Coil Co. 61
Aerocar Motor Co. 54	Diamond Chain & Mfg. Co. 51	King Top Mfg. Co. 52	Precision Appliance Co. 47
Ajax-Grieb Rubber Co. 55	Dixon Crucible Co., Joseph. 59	Kinsey Mfg. Co. 51	Prest-O-Lite Co. 60
Am. Brass & Alum. Works. 52	Dorris Motor Car Co. 54	Konigslow, Otto 51	Progressive Mfg. Co. 60
American Ball Bearing Co. 52	Dover Co., Geo. W. 45	Lansing-Mahon Press 62	Prosser & Sons, Thos. 51
American Die Castings Co. 56	Dow Portable Electric Co. 47	Lavalette & Co. 47	Quinby Co., J. M. 52
American Motor Truck Co. 71	Duff Mfg. Co. 49	Lavigne Mfg. Co. 58	Ralmes & Co. 46
Anderson Forge & Machine Co. 51	Duplex Coil Co. 46	Lear Automobile Co., Oscar. 54	Rainier Co. 56
Apperson Bros. Automobile Co. 72	Echo Horn Co. 72	Leather Tire Goods Co. 87	Rajah Auto Supply Co. 56
Ashtabula Bow Socket Co. 52	Eclipse Machine Co. 48	Lipman Mfg. Co. 46	Randall-Falchney Co. 65
Ashton Valve Co. 47	Eco Mfg. Co. 76	Lobe Pump Co. 49	Reeves Pulley Co. 58
Auburn Automobile Co. 54	Edgar Mfg. Co. 46	Locke & Co. 70	Remy Electric Co. 47
Audel & Co., Theo. 59	Edmunds & Jones Mfg. Co. 46	Lockwood Bros. 74	Renault Freres. Cover
Aurora Motor Works. 76	Eldredge Electric Mfg. Co. 57	Locomobile Co. of America. 72	Richardson Engineering Co. 51
Auto Pump Co. 56	Ellsworth, J. M. 83	Logan Construction Co. 54	Robert Instrument Co. 46
Autocar Co. 72	Elmore Mfg. Co. 81	London Auto Supply Co. 62	Ross Gear & Tool Co. 51
Autocar Equipment Co. 75	Empire Automobile Tire Co. 56	Long Mfg. Co. 67	Royal Equipment Co. 49
Automobile Supply Co. 46	Ericka Mfg. Co. 46	Majah Co. Cover	Rushmore Dynamo Works. 90
Automobile Utilities Co. 47	Excelsior Supply Co. 60	Mandeville Steering Wheel Muff Co. 60	Sallsbury Wheel & Mfg. Co. 51
Auto-Shine Co. 49	Firestone Tire & Rubber Co. 55	Manhattan Electrical Sup. Co. 46	Samson Leather Tire Co. 55
Auxiliary Spring & Ventilating Button Co. 65	Fisk Rubber Co. 71	Manhattan Storage Co. 47	Sanford Mfg. Co., F. C. 51
Avery Portable Lighting Co. 66	Forest City Motor Car Co. 76	Martini Import Co. 45	Saxon Lamp Co. 47
Baker, J. U. 94	Franko-Am. Auto Supply Co. 46	Masury & Son, John W. 67	Shaler Co., C. A. 45
Baldwin Chain & Mfg. Co. 51	Franklin Mfg. Co., H. H. 91	Mathewson Motor Car Co. 64	Shawver Co. 49
Barnett Drop Forging Co. 65	Fry, T. C. & W. L. 46	Maxwell-Briscoe Motor Co. 95	Smith Co., A. O. 75
Bartholomew Co. 71	G & J Tire Co. 55	Mayo Radiator Co. 51	Smith Mfg. Co., R. H. 34
Beaver Mfg. Co. 47	Gabriel Horn Mfg. Co. 68	McClellan, Chas. P. 52	Spare Motor Wheel of Am. 62
Behen-Faught Motor Car Eq. Co. 47	Garford Motor Car Co. 80	McCord & Co. 61	Speed Changing Pulley Co. 84
Belfuss Motor Co. 68	Gearless Transmission Co. 76	Merchant & Evans Co. 67	Spicer Universal Joint Mfg. Co. 51
Beloit Supply Co. 63	Gelsler Bros. 49	Merritt & Co. 46	Splldorf, C. F. 49
Besly & Co., C. H. 47	Gemmer Mfg. Co. 66	Metzger, C. A. 58	Sprague Umbrella Co. 82
Blasier Mfg. Co., M. E. 52	General Accumulator & Bat- tery Co. 47	Michelin Tire Co. 55	Standard Automatic Lub. Co. 47
Blomstrom Mfg. Co. 45	Gibney & Bros., Jas. L. 47	Midgley Mfg. Co. 51	Standard Battery Connection Co. 57
Boker & Co., H. 47	Goodrich Co., B. F. Cover	Miller, Chas. E. 65	Standard Co. 67
Bosch, Robert 79	Grouit Bros. Auto Co. 64	Mitchell Motor Car Co. 63	Standard Connecting Rod Co. 59
Boston Auto Gage Co. 58	Half-Nelson Tire Co. 58	Model Automobile Co. 54	Standard Roller Bearing Co. 51
Bowser & Co., S. F. 73	Hans, Edmund E. 70	Moline Automobile Co. 54	Standard Welding Co. 52
Boyle & Co., John. Cover	Hardy Co., The R. E. 46	Moon Motor Car Co. 54	Steam Carriage Boiler Co. 49
Brown, Wm. W. 46	Harris Oil Co., A. W. 47	Mora Motor Car Co. Cover	Stearns Co., F. B. 55
Brownell Motor Co., F. A. 59	Hartford Suspension Co. 74	Morgan & Wright. 74	Stevens-Duryea Co. 78
Brush Runabout Co. 82	Hatfield Motor Vehicle Co. 54	Mosler & Co., A. R. 47	Stewart & Clark Mfg. Co. 60
Buckeye Jack Mfg. Co. 65	Haws, Geo. A. 58	Moss Photo Engraving Co. 80	Streit Machine Co. 56
Buckeye Mfg. Co. 54	Haynes Automobile Co. 54	Motz Clincher Tire & Rub. Co. 55	Studebaker Automobile Co. 55
Buffalo Carbureter Co. 66	Healy Leather Tire Co. 55	Mound Tool & Scraper Co. 68	Success Auto Buggy Co. 55
Bullard Automatic Wrench Co. 53	Hedgeland Mfg. Co. 77	Muller, Albert 49	Supplementary Spiral Spring Swinehart Clincher Tire Co. 70
Bullard, J. H. 47	Heinze Electric Co. 53	Mutty Co., L. J. 52	Thomas Motor Co., E. R. 88
Buob & Scheu. 52	Heltger Carburetor Co. 56	N. Y. Gear Works. 56	Thompson Sons Co., J. P. 52
Byrne-Kingston Co. 80	Hercules Auto Specialty Co. 67	National Auto Accessories Co. 47	Timken Roller Bearing Axle. 84
Cadillac Motor Car Co. 54	Herz & Co. 49	National Battery Co. 65	Tincher Motor Car Co. 53
Cameron Car Co. 93	Hess-Bright Co. 51	National Carbon Co. 73	Torbensen Motor Car Co. 57
Canton Drop Forge & Mfg. Co. 51	Hicks Speed Indicator Co. 81	National Motor Vehicle Co. 77	Tray Plate Battery Co. 66
Carr, F. S. 52	Hoffecker Co. 46	Neustadt Auto & Sup. Co. 66	Trebert Gas Engine Co. 55
Chadwick Engineering Works. 48	Hoffman, Geo. W. 49	Never-Miss Spark Plug Co. 49	Troy Carriage Sunshade Co. 73
Champion Co., A. 49	Holley Bros. Co. 75	New England Motor Co. 74	Tucker, C. F. 46
Chandee & Chandee. 57	Holsman Automobile Co. 82	Nichols & Co., D. P. 52	U. S. Fastener Co. 65
Clark, E. S. 46	Hopewell Bros. 55	Nordyke & Marmon Co. 90	Uncas Specialty Co. 59
Cleanola Co. 57	Hotel Fredonia. 69	Northway Motor & Mfg. Co. 61	Veeder Mfg. Co. 75
Cleveland-Canton Spring Co. 49	Hotel Piney Woods Inn. 69	Northwestern Storage Battery Co. 70	Vehicle Specialty Corp. 58
Cleveland Motor Car Co. 78	Hotel Rudolf. 69	Nuttall Co., R. D. 51	Walker Co., E. C. 56
Columbia Lubricants Co. 68	Hotel Tampa Bay. 69	Ofeldt & Sons. 46	Warner Instrument Co. 86
Comptoir d'Innovations pour Automobiles 62	Hotel Tower. 69	Olds Motor Works. 54	Warner Pole & Top Co. 52
Conn. Tel. & Elec. Co. 80	Hotel Westminster. 69	Owen & Co., R. M. 55	Watt-Detroit Carbureter Co. 64
Conover Motor Car Co. 70	Howard Motor Works. 54	Pacific Tucking & Mfg. Co. 46	Waukesha Motor Co. 65
Continental Caoutchouc Co. 55	Hoyt Electrical Inst. Works. 79	Packard Electric Co. 47	Wayne Automobile Co. 55
Continental Motor Car Co. 70	Imperial Motor Car Co. 51	Packard Motor Car Co. 89	Weed Chain Tire Grip Co. 59
Continental Motor Mfg. Co. 61	Indestructible Steel Wheel Co. 49	Pantasote Co. 52	Welch Motor Car Co. 71
Corbin Motor Vehicle Corp. 71	Index Speed Indicator Co. 47	Parish & Bingham Co. 51	Western Motor Co. 66
Cornish-Friedburg Motor Car. 54	Jackson Automobile Co. 54	Parker, Stearns & Co. 66	Weston Elec. Instrument Co. 73
Correspondence School of Mo- tor Car Practice. 47	Jamesville Mfg. Co. 49	Peerless Motor Car Co. Cover	Wheeler & Schebler. 86
Cotta, Chas. 56	Jeffery & Co., Thos. B. 92	Penn. Auto Motor Co. 54	White Co., The. 85
Cowles & Co., C. 46	Jeffery-Dewitt Co. 47	Perfection Grease Co. 65	Whitney Mfg. Co. 52
Crown Battery Co. 68	Jenckel Motor Mfg. Co. 66	Perfection Spring Co. 51	Winton Motor Carriage Co. 96
	Jenkins Specialty Mfg. Co. 70	Peugeot Freres 51	Witherbee Igniter Co. 84
	Jones Speedometer 49	Pfanstiehl Elec. Laboratory. 46	Wright Cooler & Hood Mfg. Co. 68
		Picrome Hide Co. 61	Wyman & Gordon Co. 46
			York Motor Car Co. 55

**Manufacturers can purchase** Cork Insert Clutches **of the following firms**

(PATENTED)

<p><b>Leather Faced Cones</b> "Long Arm" System Co. Cleveland, O.</p> <p>Kirkham Motor Mfg. Co. Bath, N. Y.</p> <p>Muncie Auto Parts Co. Muncie, Ind.</p>	<p><b>Three Plate</b> Continental Motor Car Co. Jackson Blvd. and Robey St. Chicago, Ill.</p> <p><b>Cork Insert Clutches</b> ARE USED IN THOUSANDS OF CARS BY 44 REPRESENTATIVE BUILDERS</p>	<p><b>Five Plate</b> Northway Motor &amp; Mfg. Co. Lawton Ave. and G. T. R. R. Detroit, Mich.</p> <p>Continental Motor Car Co. Jackson Blvd. and Robey St. Chicago, Ill.</p>
---	--	--

# THE AUTOMOBILE

## Autoing Through the Island of Sugar and Tobacco

HAVANA, CUBA, Feb. 1. —Silhouetted against a dark, clear sky like stately sentries, a hundred palm trees framed such a picture as inland Cuba has never seen. Close by a trickling stream at the bottom of a stony valley, a huge flaring fire of palm leaves cast theatrical lights on a quintet that was viewed with much wonder by two Cubans on horseback and a barefooted native who stood in awed silence before the group. In the deep gloom under a cluster of palms stood the big black thing in which they had come—an automobile. It was wonderful. Automobiles they knew the great Americanos had to skip over country where there were roads. Here there was no road. This route through the hills was but a path for horses and that rock-strewn ascent—surely the big automobile could not go up such a hill. The Americans laughed and asked about the country and its trails. The dark-visaged doctor and his servant answered in that rapid fire of Spanish which makes a Cuban conversation like the popping of a Hotchkiss. But neither the exuberant Spanish tongue, nor the skillful interpreter was able to express the full measure of Cuba's surprise at such a vehicle in such a country.

It was the adventurers' first night under the star-brilliant skies of Cuba. That afternoon they had gayly skipped out of Havana, leaving behind a wholesale stock of pessimistic warnings. At garage, hotel, store, restaurant—every Cuban and every American had said: "Impossible; it



can't be done. Why, there are no roads at all in the interior. You will not get twenty-five miles away from Havana. You had better stick to the delightful speeding on the San Cristobal road, like the orthodox tourists who yearly come here."

Perhaps the wide and glorious fame of the San Cristobal road had brought these Americans

southward via the False Impression Air Line. But now that they were here, they would go into the back yard of Cuba whether or no, roads or no roads. Thus when the first day's sun sank behind a palm-fringed screen and, without even a twilight overture, the whole big night filled the stage four Americans and a leased Spanish Voice gnawed hungrily at the Cuban-cooked guinea hen which had been bought of the barefooted farmer, while they talked with the strange doctor who rode abroad at night in a wide, wild country.

"Is this the road for Matanzas?" queried an American.

"Este es el camino para Matanzas?" echoed the interpreter. And the answer started with "Si, Señor," but ended with something that sounded like a nickel-in-the-slot piano and

meant that it was about 45 leagues to Matanzas; that we could have gone another way; that the road was nothing but a series of stone-stepped hills and ragged ravines; that the next town, about a league and a half away, was called Jaruco; why had we ventured such a hazardous and altogether impossible journey; who were we, and from where did we come?

To the best of our knowledge the conversa-



GETTING ROAD DIRECTIONS FROM TYPICAL CUBAN FARM FOLK

tional transfer told the attentive audience that we hailed from Detroit; that the longest one, with the khaki suit, was S. D. Waldon, sales manager of the Packard Motor Car Co.; the other being Senors George, Crebbin, and Estep; that the automobile was a Packard, and that we intended to stay a week or more touring in the interior of Cuba. At least he talked enough to have told all this and then a little.

#### Thirty Miles the First Day.

That first day we had made thirty miles between 2 o'clock, when we pulled away from the Pasaje Hotel, and when darkness caught us at the spot we named Camp Jaruco because it had never been properly christened. It had been a hard afternoon's drive, and in a degree the evil forebodings of the Havana skeptics had been realized.

We left Havana down an aisle of palms, floored with velvet macadam and sentineled with an occasional block house which added romance to the picture of low huts dotting the rolling hills. The macadam terminated soon in a stretch of freshly graded but uneven road where a new state highway is being built. This gradually went from bad to worse until it reached the ordinary and typical Cuban trail which has never felt a roadmaker's hand. Six or seven leagues out of Havana we seemed to be in the midst of an elementary country and it was easy to imagine all manner of hardship as companion woes to the steep hills and rough ditch-like trails that formed the only route we could find. We discovered that the rough fields were often better than the trail. So we climbed a couple of hills over plowed ground and then all but jumped down a near precipice to Camp Jaruco. There was little sleep that night. We made a bed of palm leaves and brush on the ground, but it was not a good bed. The night proved chilly. We tried all places and positions, and then, in the main, devoted the silent, rather awe-inspiring hours to gathering palm bark and other fuel for the fire.

We commenced the second day on a frugal breakfast of tea and crackers and a hill-climb through a field to a peak where a farmer had a hut which overlooked so much of Cuba that we shut our eyes to the prospect. It was on this day that we began learning Cuba in earnest. We met strange things at close range. After having toiled laboriously and precariously over some rocky ridge or crept along a ravine where the one wheel would have to bump from rock to rock and the other follow a sloping ledge, we would strike a brand new fantastic setting, laugh at its quaint and innocent actors, blush at its deshabelle, kill a scorpion or two, go splash, dash through a minor ford, or stop for a moment at some hut with the inevitable:

"Oiga, chico! Este es el camino?"

We lunched at Jaruco with the whole town as audience, which retired with a yell to box seats in their respective windows when we started the motor and rushed on. For an eighth of a mile we "beat it," and remembered the Glidden tour. Then we pitched off into the middle of Cuba and for the afternoon were again lost in a land of beautiful flowers and majestic trees; red clay soil which has been out deep with the long-worn ruts of giant ox carts; ruins that seem yet to smolder with the fire that Weyler lighted; stones which carpet the earth so thickly that the only way around them is over them. Once the road dropped into a trough in the red earth. Just wide enough to let us through, it was like riding down some winding flume, not knowing whither, because the grass on the banks reached high above us. Often we found the only passage to be along the wriggling fences, and with hatchet and machete we cut down the underbrush to clear a trail we could follow.

#### Cuba's Roads Are Varied and Doubtful.

There is no continuation of any kind of road in a day's travel through Cuba. The face of the country changes rapidly and the character of the route in still greater proportion. There are no four-wheeled vehicles of any kind. We were

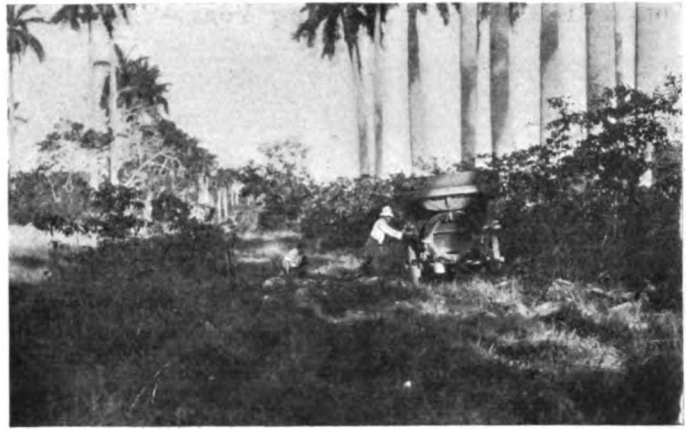

REPAIRING A PUNCTURE ON SANTA CLARA TRAIL



PACKARD CLIMBING HILL IN HAVANA PROVINCE



TYPICAL FORD IN SANTA CLARA PROVINCE.



TAKING A HACK AT THE ROAD AHEAD.

in a land where the only hauling is by ox carts whose wheels are from seven to ten feet high and which are dragged by from three to five yoke of thick-shouldered, powerful oxen and bulls. The clearance of these carts is always more than forty inches. When the ground is soft they simply plow it into straggling furrows from two to four feet deep. The only other travel is by horse. Water, food, vegetables, fruits—everything except the sugar cane and the logs goes about on the backs of ponies or pack mules.

A comparatively level path across the red soil may, in a quarter of a mile, abruptly end in a valley which is nothing but a mass of huge boulders; it may lead to a score of mud holes or to a long stretch where the ruts have been cut so deep and so numerous that they will never be erased and where there is only one course—to jump around on the ridges in a car-straining, nerve-racking, wheel-twisting, tire-abusing effort to avoid dropping into any of them. Then, again, a few miles will bring you to a country where the road is marked by long rows of palms set by early Spaniards but between which there is nothing except an endless river of rank grass, hiding stones, stones, stones.

That second day we began to get into the region of rivers and went through a rehearsal of the great continuous show of succeeding days, the act of wading into a river to find out where might be a safe path for fording it. We were glad to end the day, with 34 miles gained, at a farm-house hut with a few square feet of grocery store in one corner. We ate the typical country meal, garlic-flavored, greasy and made up of eggs, chicken and rice, tomatoes, fried potatoes, and bread. We added tea. Coffee in Cuba is "solo," which means so black that one must be in good training to drink it; or "con leche," which means about half-and-half with warm Cuban milk, which is not the kind of milk a foreigner is used to. We slept on cots in a well-ventilated corner of the house—at least we stayed on the cots, while we listened to queer night noises, fought fleas and discussed this peculiar "land of Manana," where nothing is done to-day and where a lot of things that ought to be done probably never will be done.

#### Where There Was No Bridge.

At daylight we swallowed some coffee and struck off on the nine-mile stretch to Matanzas. We met a section of State road in process of construction, and mounted its rough stone but level surface only to reach, in a few hundred yards, a wide chasm where the bridge had not yet been built and the river flowed between banks a hundred feet deep. This is a bad habit of Cuban rivers. They can be forded by carefully selecting a course over ridges in the solid rock which forms their bed. It is a harder task to reach them. The only way down the precipitous



IN THE SPOT LIGHT AT JARUCO, BEING EXAMINED BY THE CURIOUS.

bank is through some ravine or washout. This invariably is a crooked path of rock with steep drops and actual steps three and four feet high. Sometimes a crooked, lengthwise rut, worn by years of horse travel and by ox carts which have been hauled up the path, made it necessary to run the car down with the wheels on the almost vertical walls of the rut. Often we were forced to take the mattock and cut a slender shelf for several yards along such a wall, in order to give the car even the slightest footing. Once at the bottom, there is the strip-and-wade-into-the-river act to determine the proper place to cross; the ford itself, with a rubber coat over the radiator to keep water out of the bonnet, and then the climb up a ravine that matches the one by which the descent was made.

We stopped a few hours in Matanzas to buy some groceries, search for gasoline and add to our supply of road-making implements. We also changed interpreters, and this time got one Geerken, clerk of the Hotel Paris, whom we called Roe and who turned out to be not only capable and willing but comedian enough to help turn many a deep mud hole or turbulent river into a joke.

Eastward the Star of Hope took its way in a Packard car, over a new good road which stopped after nine miles so



ENTERING A FARMYARD, WHICH MEANT SUPPER AND A PLACE TO SLEEP.





CENTRAL CUBA ABOUNDS WITH GAME.

suddenly in a natural stone quarry that we once more adopted across-lot tactics. A river which had been described as fifteen feet deep turned out to be almost dry and we hardly missed the bridge which had once been there but which the Spanish army had destroyed while industriously engaged in keeping a big bunch of machete slingers from following. Towns were thick along here, and we much enjoyed coming out of a hard fight against ruts and stones into a level area where from the collection of houses there invariably streamed a horde of young and grown-up children whose eyes popped out, whose tongues could hardly answer our "Que hay!" and whose feet finally pattered rapidly on the stone as they chased us up the road to prolong the final view of this new American invasion. We had a lot of trouble convincing the natives that we did not belong to the United States army. What else but that great, all-powerful United States army could have such a vehicle wherewith to travel over such trails as those of Cuba? Our day netted 44 miles, which was pretty good considering our four-hour wait in Matanzas. We ate under the flickering flame of an acetylene lamp in the main room of a farmhouse called Tosca. In rural Cuba the poor use candles or simple kerosene lamps, but the more pretentious have acetylene, manufactured in a small generator kept outside the house.

#### Into Heart of Sugar Cane Region.

Now we were getting into the heart of the sugar cane region and our fourth day earned us 60 miles, some of the going being pretty good. Ruts we encountered by the mile for there was much hauling of sugar cane hereabouts. Also more stones and rivers and those long stretches where there is no road, and we simply picked a way to our taste across the stone-strewn, grass-covered hills and flat lands. Everywhere ruins to remind of the war, and in the towns "Vive la

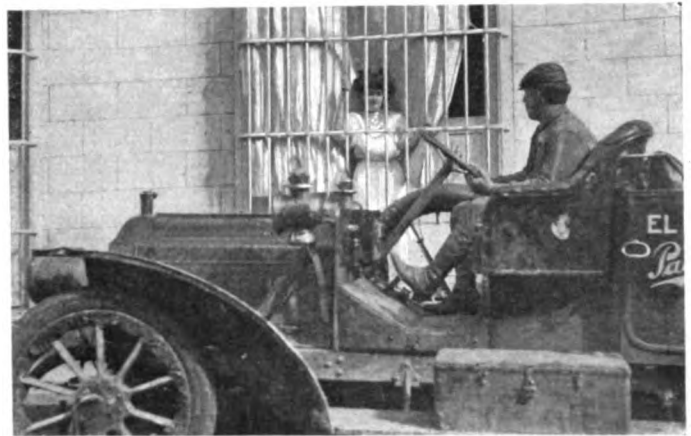

"QUE HAY DE NUEVO, SENORITA!"

libre Cuba" signs calcimined on the sides of the houses. The fighting had evidently been the real thing in this neighborhood. In fact the rural guard who sold us a machete said he had killed seven Spaniards with it.

We stopped at an immense sugar mill to get a glimpse of its inner workings, and a drink of water which was brought to us in a "porron." This is a bottle which you must not touch with your lips but must hold several inches away and try to hit your mouth with the stream of water.

Macagua was an interesting night rest. The whole countryside had come to town, for it was Sunday and there had been a ball game between local teams; also there was a dance in the hotel office that evening and we attended this in full dress—flannel shirts, khaki knee trousers, leggins, mud and four days' growth of beard. It was not much fun, so we went outside and showed a lot of fussing, jabbering town celebrities how to send up a big colored paper balloon.

#### Into Hillier and Wilder Country.

For five more days we went on into the hillier and wilder country. Monday was our record day—63 miles. Most of these were made through an immense flat country which was either swamp, out of which grew grass higher than the car and which hid wet and hard ground and stones alike, or it was a high plateau, where there was not a thing in sight but royal palms, scattered clumps of shrubbery and ponds. Here the surface was fairly hard, although to a northern road-trained eye it would have looked rough and arduous of travel. We got over it fairly well until we lost our way and only found populated country by cutting to the railway track, which we knew to be to the south of us, and then by following along its right of way to the next town. Some time when you are riding on a train, look for a place where the right

(Continued on page 192)

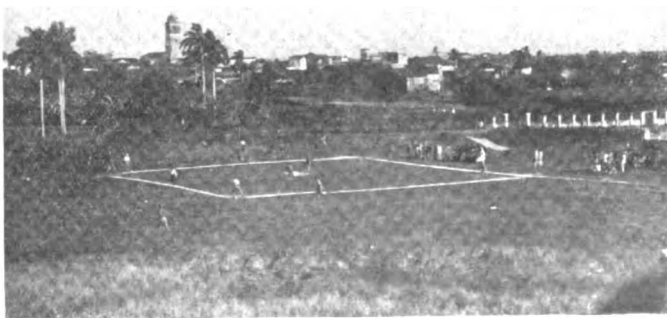

AMERICAN NATIONAL GAME IN CENTRAL CUBA.

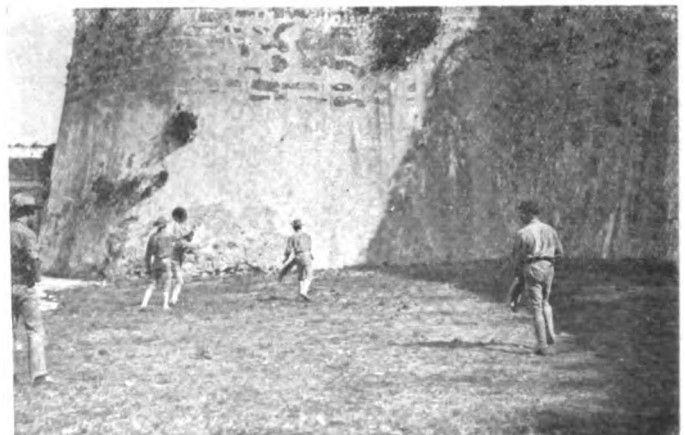

JAI ALAI—THE CUBAN NATIONAL GAME

# TOURING IN TENNESSEE, ALABAMA, AND GEORGIA

By PATHFINDER.

ONCE leaving Nashville, the route which we have followed in our White steamer is practically the same as that taken by the armies during the Civil War as the Union forces slowly but surely advanced into the territory of the Confederacy and swept the Southern troops before them. This is not a coincidence, for I deliberately planned our route after consulting the Civil War histories. There are no road maps covering this section of the country, and I could think of no better way of finding out the lines of least natural resistance, and, therefore, the probable location of the best roads, than to search into the records of the war.

Before leaving Nashville, we visited several points of interest about the city, including the tomb of President Polk and the famous "Hermitage," the old home of Andrew Jackson. The latter is located about twelve miles from the city on what is known as the Lebanon Pike. The afternoon was half over when we finally started on our way and we had an easy three hours' ride through Murfreesboro to Shelbyville (57 miles from Nashville), where we spent the night. Nashville is in Davidson County, and the roads in that county are free, but thereafter there were toll gates at frequent intervals, and we paid all told \$1.95 between Nashville and the Alabama boundary.

At Murfreesboro we saw what is left of the fortifications which were erected at the time of the famous two-day battle, and at Shelbyville were other sights to revive war memories, as it was here that the Confederate army spent the winter after their defeat at Murfreesboro.

At Shelbyville we could have turned southeastward and made Chattanooga in probably one day's ride, but I preferred to go southward into Alabama, following the lines of the military operations. The toll road continued south from Shelbyville through Fayetteville and almost to the State line. And here I would like to offer a word of warning to those tourists who may follow this route. The toll gates are kept down and are not raised until the toll has been paid. This procedure is all very well—provided you see the gate. We were bowling along toward Fayetteville at a good rate of speed when suddenly we saw a toll gate blocking the road only a few yards in front of us. I jammed on the brakes with every ounce of strength I could muster and brought my car to rest with scarcely a foot to spare. The gate was an unpainted affair of almost the same color as the road, and it is no wonder that none of us saw it until we were right upon it. I remonstrated angrily with the

gate keeper. "It is the orders to keep the gate down," he explained. "But surely you hang a lantern at night?" I asked. "No sir," he replied, "never had any order to do so." It was then that I began to realize a general truth which was more and more impressed upon me as we advanced, namely, that in this section of the country, as

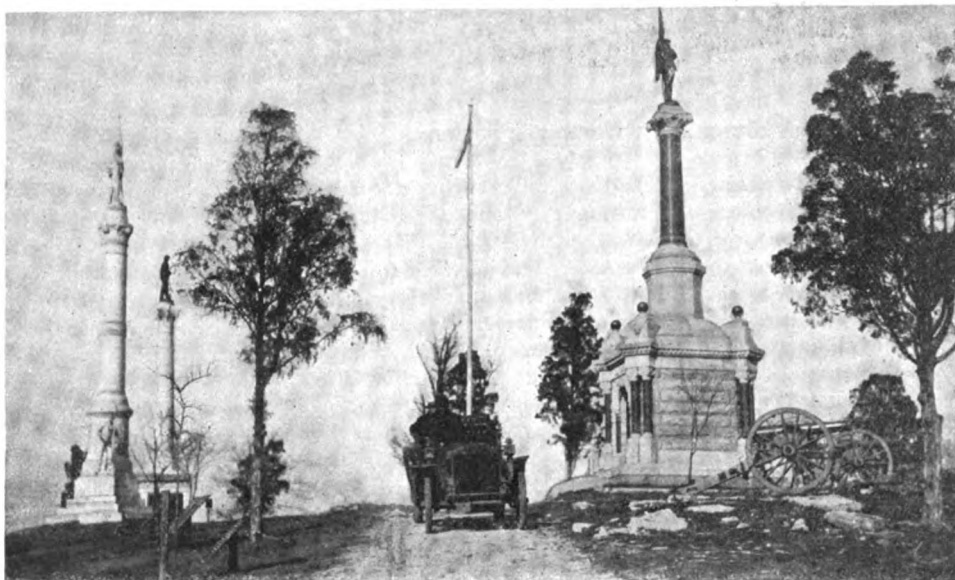

A PAUSE ON THE SUMMIT OF ORCHARD KNOB NEAR CHATTANOOGA.

regards the maintenance and condition of the highways, the traveling of motor cars over them has not received any consideration whatever. The conditions are adapted to horse-drawn vehicles—and that is all.

### A Century from Nashville to Alabama Line.

It is almost exactly 100 miles from Nashville to the Alabama line. This section is distinctly Southern. The "Soldiers' Monument" in each town is invariably a Confederate memorial. On this part of our journey we had our first glimpse of the cotton fields and realized we had arrived in Dixie.

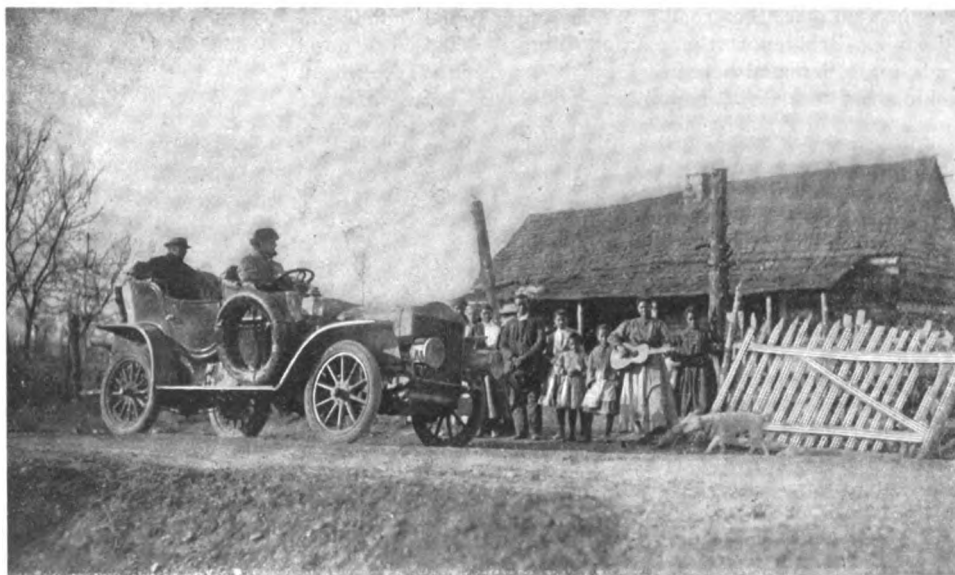

GEORGIA PICKANINNIES GROUPED ABOUT THE WHITE STEAMER.



ALABAMA COTTON GIN WITH WATER POWER.

From the State line we had 18 miles of fair road to Huntsville, Ala. Here we turned east and soon had the pleasant sensation of crossing two considerable ridges on a road without water breaks. After leaving the town of Gurlie, we crossed what could fairly be called a mountain, for the first time since leaving Pennsylvania. The road over the mountain was only partially completed and was so mushy that we used almost as much power going down as we had going up. What was our surprise, therefore, to turn from this road abruptly into a stretch of perfect macadam. We had come into Jackson County, Ala., and soon we learned not to be surprised at anything within its borders. Never have I seen such contrasts between good roads and bad roads as we saw in Jackson County. Possibly 75 per cent. of the going was over fine pikes and the other 25 per cent. was over roads which are apparently absolutely neglected.

We spent that night at Woodville, a little hamlet 150 miles from Nashville, having covered 93 miles for the day. There was more rain that night and the next day we struck many soft places where the only thing to do was to get brush and stone to put in the path of the wheels. Interspersed with roads of this kind were occasional stretches of fine pike, with here and there a road made up mostly of loose stone where we found that we needed every bit of the unusually liberal clearance which distinguishes the White steamer. The distance covered that day, to our night stopping place at Bridgeport, amounted to only 58 miles; from which it is evident that Jackson County, Ala., is not an ideal touring section at this time of year. We were told, however, that in summer the roads are in very good condition.

Leaving Bridgeport the next morning we had very good roads to Jasper, and here we found the person we had been seeking for two days, namely, an individual who was able



FORDING THE SHALLOW SEQUATCHIE RIVER.

to tell us how to get into Chattanooga. Here let me point out that we have had the hardest time in getting road information ever since leaving Nashville. At that city even John T. Landis, who has driven his car from Nashville to Quebec, confessed that he had never been to Chattanooga and he did not know of any one who had. When such a veteran tourist could give us no information, imagine how much we could learn from the farmers along the road. Please keep in mind that Chattanooga is not an easy place to reach by automobile. Nature seemed to have tried to shut off Chattanooga from the outside world and Man has done but little to thwart her purpose—at least from the autoist's point of view. Chattanooga is located in a little valley from which mountains rise on every side. As if this was not sufficient isolation the Tennessee River twists and bends about the city, seeming to press it back against the mountains. Therefore, two problems had been before us ever since leaving Nashville, where we could cross the mountains and where we could cross the river. Our historical guides failed us completely, as the army had, at will, taken to the railroad right of way or had been carried on the river in boats. We were, therefore, highly pleased when we chanced to meet at Jasper a gentleman who owns a White car and who gave us the desired information.

Acting in accordance with his directions, we turned toward the Tennessee River and headed for Rankin's Ferry. Here we were taken across in a flat-bottom boat, propelled by oars, and, on the other side, we had a fine little job of road building to make our way up the muddy incline which, but two days before, had been part of the river bottom. What good did it do for us to suggest to the ferryman that he dump a little stone into this quagmire? As I said before, the peculiar necessities of the automobile have not entered into the calculations of the people in this section.

From the ferry we had seven miles of rather rough going, crossing in the meantime Raccoon Mountain. On our way up the mountain we several times forded a mountain stream and the fording places looked as if they might be deep at certain seasons. On the far side of the mountain we struck a good pike, which led us into Chattanooga, 247 miles from Nashville by our indirect route.

Before reaching the city this pike leads along the side of Lookout Mountain. If one should slip over the side of the road he would land in the Tennessee River, several hundred feet below. If it were not for this feature I might venture to suggest Lookout Mountain as a suitable place for a great hill climb. We arrived in Chattanooga in time for lunch and had a half day in which to look over the city. The next morning we resumed our journey southward. A boulevard leads from the center of the city to Missionary Ridge, where commences a fine stretch of government road.

From Lafayette and on through Summerville we found the road fair to poor. The soil is composed of reddish clay and sand which washes out freely and leaves the road full of ruts and holes. Yet we had good solid ground under our wheels and made good progress to Rome, 75 miles from Atlanta, and here spent the night.

The next day it rained continuously, and we had an opportunity to see what a fine slippery mixture the Georgia clay can make. Although it was hard work keeping the car in the center of the road, we found that there was considerable bottom to the road.

The 400 miles between Nashville and Atlanta have been by far the worst we have yet covered. The heaviness of the road, however, has been due entirely to the abnormally heavy rains, and I have no reason to believe that the tourist who has made his way as far as Nashville will find the journey from there to Atlanta particularly severe at a more propitious time of the year.



SEVENTEEN MILES OUT OF DAYTONA ROAD IS EXCELLENT.

### FLORIDA COAST ROUTE EXPLORED.

Though the Cleveland pathfinder, which has just accomplished the run from Jacksonville to Miami, has made no attempt to remove mountains or to make the difficult path plain, it has done sufficient useful work for the main body of tourists to appreciate its pioneer trip. There are enough natural difficulties on this run of 371.8 miles down the Florida coast without calling upon the participants to add to their difficulties by picking out a trail where automobile had never before penetrated. The coast run is possible, but only on condition that the automobile attempting it is of robust construction and handled with skill and intelligence.

James Laughlin, 3d, who drove the Cleveland 40-horsepower Pathfinder, reached Miami one day ahead of schedule, notwithstanding the breakage of a front spring between St. Augustine and Ormond. Tire trouble was *nil*, the Continentals employed being as good at the end of the trip as at the commencement. It was necessary, however, to take advantage of every bit of daylight for driving and to work on several occasions late into the night to prepare the car for the arduous trip of the morrow.

In the pathfinding trip the hardest day's work was from Grant to Jupiter, a distance of nearly one hundred miles. Grant, a city of one house and an hotel, was reached late at night from New Smyrna. Arrangements were made with some fishermen to ferry the car across the river Sebastian, where a guide was to be picked up. In the seven miles of deep woods leading to the ferry the party became lost at 2 o'clock in the morning and ran around for two hours trying to discover an outlet. A house was finally found and a guide secured. After being ferried over the river by hand power, a second guide was secured at Vero, and after plowing through 20 miles of sand, reached Fort Pierce.



BETWEEN ST AUGUSTINE AND ORMOND—MAKING A FORD.



CROSSING ONE OF THOMAS WHITE'S TRESTLES.

Reuben Carlton, an old-time cow puncher, here plunged the party into the deep woods in search of the Capron trail. For thirty miles the going was through a roadless country spotted with roots which frequently had to be cut away, with long wiry grass reaching up to the radiator, and swamp patches that occasionally caressed the hubs. The bridge had been washed away from one stream and it was necessary to construct a ford by digging away eight-foot banks at either side. When the car finally lunged down the steep side the angle was so steep that the driver only was able to maintain his seat. A twenty-five-mile trail through the pine wood followed, then there was a plunge into a swamp road, which called for the travelers to step out into a mocassin snake den. After more bridge building and the hacking away of stumps, Jupiter was reached at a late hour. The terrestrial city's accommodation was found to be limited to three visitors at a time. As there were five in the party two had to turn in for the night under a tent by the side of the car.

Now and again a spot would be come across where a speed of 20 to 30 miles an hour was attainable with ease. As such spots were generally through beautiful orange groves and pineapple fields, and to the accompaniment of sweet singing birds and the drone of winged insects, the 30-mile limit was quite sufficient.

There are now signposts the entire distance from Jacksonville to Miami, marking the route to be followed by the tourists, who will leave the former city on February 18. Those already entered for the run comprise a couple of Maxwell cars, two Cadillacs, two Clevelands, an Elmore, a Ford, and a Winton. There is no restriction as to horsepower or equipment, all cars being available on an equal basis, and an interesting trip is confidently expected.



REMOVING A STUMP THAT BLOCKED THE WAY.



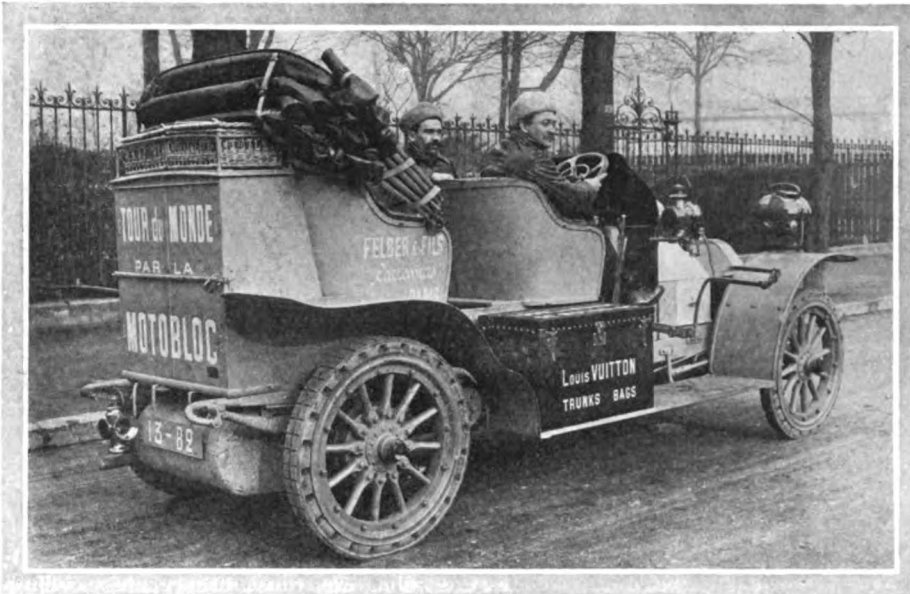

HOW THE MOTOBLOC HAS BEEN FITTED FOR RUN FROM NEW YORK TO PARIS.

### FEATURES OF FRENCHMEN FOR WORLD TOUR.

PARIS, Jan. 27.—Though all are destined for the same struggle, there is a wide diversity in structural features and methods of equipment of the four French cars which will be embarked on the *Lorraine* for New York February 1.

One of the first cars to be ready was the 40-horsepower Motobloc, built in Bordeaux. Structural features are a 40-horsepower, four-cylinder engine with flywheel between the two pairs of cylinders, motor, clutch and transmission forming one block—hence the name. Chain drive is employed. Except for the frame being lined with soft wood, the chassis follows standard lines of construction. Pneumatic tires have been abandoned in favor of a special type of cushion tire with individual air chambers. The body is practically a four-seated runabout, the rear seats being brought sufficiently forward to allow of a large chest being built at the rear for storing provisions and carrying parts. A rack above the chest allows for loose cases being carried. In the demonstration about town champagne cases occupied this position. Running boards are wide and fitted with trunks; searchlights are over the fore end of the mudguards; the body is covered with a folding hood, and driver and mechanic are further protected by a short leather wind shield. Patriotically the bonnet has been painted with the national colors; commercially the body bears the name of its maker, the car of its constructor, the trunks of the supplyman and the wine basket the name of a well-known brand. Godard, who will handle the car, drove the Spyker from Pekin into Russia, where he had to abandon with magneto troubles.

De Dion has selected a standard 40-horsepower model, strengthened in every feature, filled the frame with soft wood, and wrapped it with felt and insulating cloth to protect it from the cold. In the lower part of the specially designed body provision has been made for 260 gallons of gasoline. Above the tanks are commodious lockers for carrying supplies, and above this the seats, the whole being protected by a cape hood with side cur-

tains, making an entirely closed-in car with provision for sleeping. A mast is stepped forward, the intention of the driver being to use a sail in journeys over the ice. Before the driver is a compass, a sextant, and a roll map of the country to be traversed. A small electric motor will provide light at night. Collignon and Cormier, who went through the Pekin-Paris run, have personally supervised the fitting out of the car. Hans Hendrik Hansen, the explorer, will be the driver. No expense has been spared in fitting out, and De Dion is a decided favorite among the foreign starters.

Sizaire & Naudin, being builders of a light low-powered car, have stuck to their standard chassis for the race, the vehicle being a 12-horsepower, four-cylinder car. Paul Pons, who started from Pekin on a Contal tricar, has been chosen as driver of the little car.

Little has been learned about the Werner, which M. Lelouvier, said to be the originator of the tour, will drive from New York. It is in the motorcycle and small car field that the firm has earned its popularity, and it is rather surprising, therefore, to find that a 40-horsepower engine is being used. Officials and organizers, including the *Matin* editor, will travel with the contestants to New York.

### AEROPLANE'S FIRST FLIGHT ENDS BADLY.

PARIS, Feb. 3.—After flying 65 yards at Bagatelle, M. Delagrangé procured a new aeroplane, almost a duplicate of the one used by Farman, and met with disaster on the Issy ground. When traveling at a rapid rate one of the propeller blades snapped off, breaking the crankshaft and cracking the crankcase. The power plant had been especially well studied, the eight-cylinder Antoinette motor being of the latest model and equipped with a tubular radiator carried in a forward portion of the frame. The forward equalizers were a feature not tried before on aeroplanes built by the Voisin Brothers. No reason can be discovered for the breakage of the propeller, the material apparently being perfect. It is expected that further trials will commence in a week.



DELAGRANGE AEROPLANE, WITH EIGHT-CYLINDER ENGINE AND RADIATOR FORWARD.

# SOME OF THE VENTURI TUBE PECULIARITIES

By E. A. HUENE.

THE increasing use of some form of Venturi tube carbureter shows either a revulsion in favor of simplicity at any cost or the recognition of some element in this type which in practice accomplishes the best results achieved by other forms using some system of supplemental air orifice, or oil retardation at the nozzle. Nevertheless, a review of late contributions by various engineers upon the Venturi type fails to disclose harmony, either as to what it accomplishes or as to scientific reasons for its conduct in practice. From a late article by David Landau on "Carbureter Design

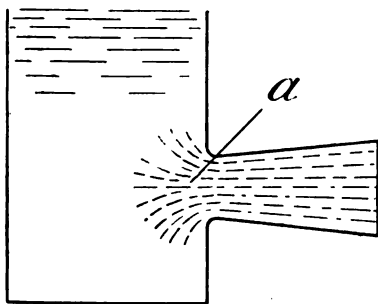

FIG. 1.—Showing point of depression.

with Reference to the Venturi Type," it may clearly be deduced, if not actually expressed, that it does not produce the necessary compensation between air and oil by reason of its inherent arrangement: Not being within the province of this article to question premises when the conclusions arrived at are indisputable, it is sufficient here to state Mr. Landau's conclusions: "The velocity of discharge in the various sections is inversely proportional to the area of the sections. Hence it is evident. . . that the pressure is. . . least in the smallest." With this simple explanation, we arrive at the real fact, which he sets forth thus: "When a pressure gauge is placed at *a* (Fig. 1) the pressure is found to be less than atmosphere; in fact, the fluid is discharged into a partial vacuum." After much valuable formulæ and deduction the practical conclusions arrived at are that, as to mixture, the Venturi possesses these advantages: "Homogeneity of mixture. . . reduction of wire drawing. . . and facility in starting."

Upon the other hand the several makers of this type for the market value it apparently as accomplishing air and oil compensation, without the complication of the supplemental air type. This view is specifically set forth as follows by F. E. Watts in his recent contribution to a contemporary on "Carbureter Requirements in Two and Four-Cycle Engines," where he says: "It is claimed with certain forms of converging air nozzles, like two hollow truncated cones with their small ends brought together, there is a point where the suction remains practically constant whatever the velocity of air flow. If the fuel nozzle is located at this point we shall, of course, have a constant mixture at all speeds."

If the results obtained with the Venturi type were in all ways equally good as those from the well designed supplemental air type at its best, it would not be worth while from any but an academic standpoint to discuss the reasons for such conduct. But it has already appeared, with but a small part of the authorities quoted, that this is still debatable ground. Consequently it seems desirable to further analyze the actions of this type and consider the laws of physics which govern them.

Take for a starting point the gauge demonstration that there exists a space, or volume of low pressure, at some point in the throat of the Venturi tube. The shape and boundary lines, even if well defined and constant, which they probably are not, are not subject to exact calculation, nor to very close observation, though the latter may be

had in a rough way by constructing a tube Venturi with flat, parallel glass sides, as in Fig. 2. Upon blowing smoke through this tube, the form of low pressure space can be observed in two dimensions, as the smoke, in spite of its tendency to follow the flat glass sides to some extent, still leaves a low pressure area thereon. This area may be considered, then, as a section cut through the center of a true Venturi tube longitudinally.

Having demonstrated that it exists, the next inquiry is as to the laws governing it, after which may be discussed the effect on the oil flow. Mr. Landau determines the matter from the following laws: "Equal quantities of air pass given points of varying section in the same time," wherefore "the velocity of the air in the various sections is inversely proportional to the sectional areas." Hence his conclusion that the pressure is greatest at the largest section and least at the smallest section, the throat. There seems some doubt, however, whether these laws fully apply to the phenomena observed, as there are some other laws governing the flow of gas and air along surfaces which, though less important in general, have much, if not complete, control of the action of the Venturi tube.

The original Venturi experiment consisted of emptying a reservoir of water by means of driving a stream of water up a gently inclined plane from the level of the stream to the edge of the reservoir. Later experiments determined that a stream of air through air or through water produced like action. Many simple experiments show this action, such as the flame of a candle bending toward a stream passed close by it, or the action of a curved vane pivoted at its center with a stream directed tangentially along one surface, when it moves toward the stream and may be made to revolve in that direction by advancing the stream; when a stream of air is blown through the bottom of a hemispherical cup in which a light sphere is lying, by the inability to dislodge the sphere which, if inverted, resists gravity. In a similar manner a light sphere may be suspended in a flowing jet of air or liquid. These phenomena are generally designated in physics as the pneumatic paradox. It is apparent that upstream surface pressure is diminished by reason of the radial streams until down stream surface pressure predominates. To more clearly understand this statement take the experiment of the hemispherical cup, Fig. 3.

Let *ab* represent the hemisphere and adjoined upstream tube, *c* the sphere and *de*, *d'e'* the radial streams. It is quite evident that friction, or adhesion, which was considered



FIG. 2.—Illustrating the anomalous action of the Venturi tube.

the reason of the original Venturi phenomena, cannot here apply, as its assumption would work a quicker discharge instead of retention of sphere *c*. Nor has the presence of the hemisphere *ab* any bearing on the phenomena, as the sphere suspended in a free air jet demonstrates. Directly applied to the carbureter there will be found little in the above experiments and laws applicable, the nearest approach, probably, being that the same well known laws that do here apply solve the phenomena of the sphere, Fig. 1 and kindred. The law of centrifugal force needs no exposition, there-

fore it is only necessary to state one other law, or proposition, to wit: A moving fluid tends, on account of adhesion, to follow a surface, where the velocity of the fluid and the curvature of the surface are not too great.

Referring back it will be observed that Fig. 2, which for the moment may be considered the Venturi tube of common carbureter design, is but a modification of the hemisphere of Fig. 3, minus the contained sphere, which sphere is in the latter experiment surprisingly approached in form and location by the low pressure or vacuum space of Fig. 2.

The curvature of the air stream beginning at the throat is, then, caused first by the adhesion to, and consequent following of, the diverging wall surfaces. The centrifugal force tending to resist this turning once having been overcome, adds its effect in enlarging the inner, low - pressure space. Consider the

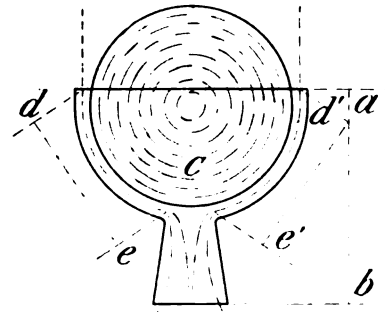

FIG. 3.—Experiment of the hemispherical cup.

oil nozzle inserted into this space of low pressure at the throat and the conditions are complete for study of the effect of carburetion. Upon induction stroke of the motor the air in the tube assumes the position shown in Fig. 2; into the low-pressure space oil from the nozzle readily expands in a finely divided state and is readily taken up by frictional contact and affinity between it and the inner surface of the surrounding shell of passing air.

Some general observations in conclusion, deduced from the matters set forth, are: That the assumption that the Venturi tube carbureter has a compensating action which neutralizes the tendency of overrichness of gas at high speed is not well founded; that it may, nevertheless, well give very good results in practice up to a certain speed for a given throat angle design on account of the homogeneity of its mixture, which is largely promoted by the location, shape and uniform expansion of its low-pressure space in action. Its limitations in furnishing a well commingled charge of gas are readily seen to be at the point where, with given throat angle and given speed, the surface tension of air following carbureter walls is overcome by its tangential centrifugal force tending to pass the air by nozzle in a circular column of constant diameter instead of as a hollow oval of varying length.

Some suggested improvements in this type are: A deflector of such form at the throat as to positively establish and maintain the radial streams around nozzle; "rifling" the throat for the same purpose, thus inducing a vortex, or whirlpool beginning at nozzle and extending downstream. By the use of a proper throat angle in this connection a low pressure space may be induced which will not contract in diameter at any induction speed, but will uniformly expand downstream. It is quite possible that this construction may promote good mixture to such an extent at all motor speeds as to leave little necessity for supplemental air compensation. If such compensation is deemed desirable, a direct vacuum oil balance is possible.

#### GAS POWER SECTION A. S. M. E. MEETING.

The first meeting of the Gas Power Section of the American Society of Mechanical Engineers will be held on Tuesday evening, February 11, in the Engineering Societies Building at 29 West Thirty-ninth street, New York. The subjects discussed will be varied and interesting.

#### PARIS 1908 SALON TO BE RUN ECONOMICALLY.

PARIS, Jan. 27.—Parisians will not be deprived of their annual display of automobiles in the luxurious palace in the Champs-Élysées, the Chambre Syndicale de l'Automobile having decided in principle to hold an eleventh annual exhibition next December. Soon after the tenth annual show turned out its thousand of electric lights the question of the advisability of holding the Salon every two years, instead of annually, was brought up for consideration. It was understood that if this were done some arrangement should be arrived at with the promoters of the rival show in London, by which the British event should also be held at intervals of two years only. Apparently no such entente was possible, and the Grand Palais will see an eleventh annual automobile exhibition before the end of the year.

The lavish expenditure which marked the tenth annual show will not be a feature of the coming event, the manufacturers' committee having decided to recommend its members to adopt a more modest type of ornamentation. The central committee, however, will maintain the same decorative display for the interior and exterior of the hall. After expenses have been met a certain part of the profits will be distributed among the exhibitors. Free entries will be considerably limited, those given being made strictly personal, either by the use of photographs on the cards or other means. Of late years free passes have been so extended by the promoters that crowding of the hall by non-purchasers has resulted.

#### WIRELESS TELEGRAPHY AN AUTO EQUIPMENT.

PARIS, Jan. 27.—Marconi has been taken into the automobile fold. The first application of wireless telegraphy to the most modern of methods of travel was seen at the recent Brussels exhibition, where a Pipe limousine was fitted with Marconi's transmitter and receiver. The tall mast above the roof of the limousine would doubtless be found a considerable inconvenience in touring, where overhead bridges and other obstructions are met, and there is little probability of the arrangement becoming a standard equipment on touring cars. It is stated that the automobile wireless telegraph station has been used extensively in army operations and found to be eminently satisfactory. In comparison, even the ordinary field telegraph service was vastly inferior for transmitting orders.

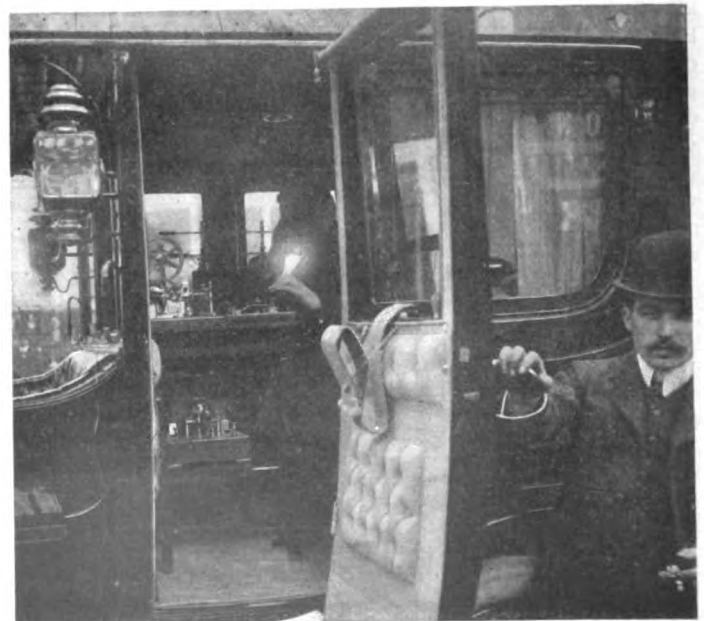

FIRST "WIRELESS" STATION FITTED TO AN AUTOMOBILE.

# A GASOLINE METER FOR AUTOMOBILE USE\*

UTILITARIAN ideas in connection with the automobile do not appear to be fertile, judging by the experience of the Association Générale Automobile, a French body which desired to develop the best apparatus for abolishing smoky exhausts, for preventing light-fingered gentry from borrowing an automobile without going through the formality of asking the owner's permission, a device to enable drivers to hear sounds in the rear of the car, to see what is passing behind the vehicle and to measure the exact amount of gasoline consumed. Schemes are plentiful, but few of them had the merit of being sufficiently practical to warrant a reward. Among the exceptions were a "Flic automobile" to prevent a car being stolen, and a gasoline meter designed by Chauvin & Arnoux.

There is a sufficiency of machines on the market for measuring liquid for the problem to appear, at first sight, a simple one. Closer examination soon shows that there is little in common between an instrument for measuring water, gas or electricity and one to be used on an automobile to indicate the amount of gasoline consumed by the engine.

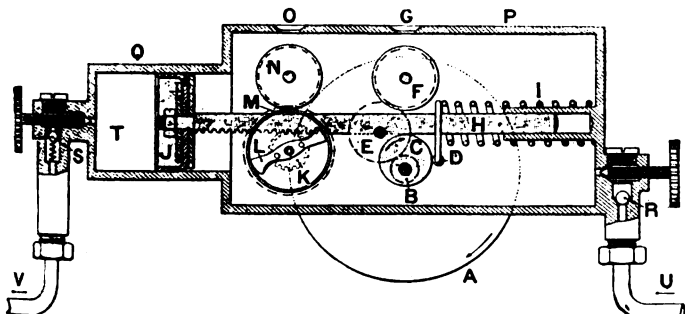

FIG. 1.—Sketch showing principle on which the gasoline meter operates. Gasoline arrives at U, is driven under pressure by the piston J into Cylinder T, and travels to carbureter through valve S and piping V. By rack and pinion M the number of liters is registered at O; number of revolutions of the crankshaft are registered at G.

The driver of a car is lord and master of every bit of mechanism about it, and although, in his case, the object is not to make the indicator show as little, but as much as possible, he could soon accomplish his ends if special pains had not been taken to thwart him. For instance, with an indicator fixed somewhere on the piping, between the gasoline tank and the carbureter, all that would be required would be to disconnect the piping at the carbureter, turn the pipe into a can and pass through as much gasoline as was considered necessary. In such a way the car would consume ten, fifteen, or twenty gallons in a very short space of time, every drop of which would have been registered without the motor making a revolution.

In the Chauvin & Arnoux instrument this has been guarded against by making the flow of gasoline impossible except when the motor is running. Thus, supposing a 30-horse-power machine consuming two gallons of gasoline per hour at 1,600 revolutions a minute, the chauffeur would be obliged to turn his engine over at 400 revolutions for four hours in order to gain two gallons. Any man who would undertake this would certainly be entitled to the fuel he obtained.

### Principle on Which Gasoline Meter Is Based.

The principle of the apparatus is simple. A Pulley A (Fig. 1) is connected to the motor by a belt, the gearing being such that for one hundred revolutions of the motor shaft the pulley makes one complete turn. Thus, whenever the motor

\*Translated from *Omnia*, by W. F. Bradley.

has made one hundred revolutions, the cam C, attached to the shaft of the pulley A, will have made one. With each revolution of the cam the arm D (Fig. 1) is driven to the right; as the arm is keyed to the connecting rod H, this and the piston are operated by the same cam. If the arm D is in contact with the cam the maximum movement will be obtained; if the two are separated, the movement will be in proportion to the distance between them.

It will be thus seen that the function of the cam C is to drive the piston from left to right, while the function of the spring I is to bring about an opposing movement. Supposing the apparatus to be full of gasoline, it will be readily understood that the cam, by driving the piston to the right, will aspire gasoline into T, under the leather-faced lips of the piston, while the spring I will drive the same liquid through the valve S to the engine.

The amount of gasoline contained in T should, in consequence, be sufficient to meet the wants of the motor during the time necessary to make one hundred revolutions, for, as has already been seen, the cam C only causes one aspiration per 100 revolutions. The dimensions of the cylinder Q have been calculated so that with the motor running at full power the whole of the gasoline contained in T will not be consumed during the 100 revolutions. In practice, indeed it will be found that the opposite will occur, the motor being throttled down to such an extent that it will consume but a half, a quarter, or may be but a tenth of the full amount of fuel contained in T. In such a case, the liquid being practically incompressible, the spring I cannot drive the piston more than a half, a quarter, or a tenth of its maximum stroke. The reciprocating movement of the piston is therefore always proportionate to the amount of gasoline consumed by the motor. If fuel con-

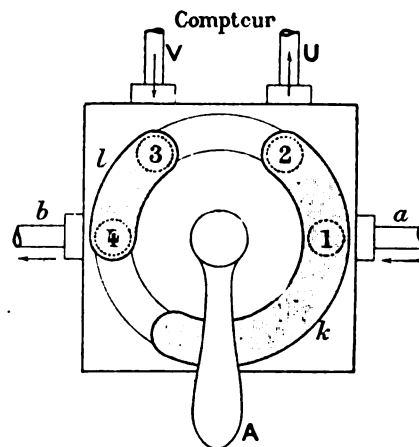

FIG. 2.—Two-way cock by which gasoline arrives from tank, is passed to the gasoline meter, and sent to carbureter. Position in sketch shows the meter open.

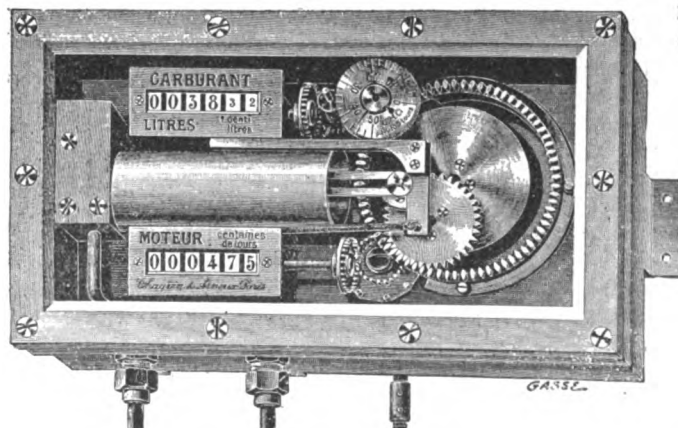

FIG. 3.—Sketch of the complete apparatus as seen through plate glass front. Upper dial shows amount of fuel used; lower one indicates hundreds of revolutions of the motor. At base, outside the casing, are shown flexible shaft, inlet and outlet.



sumption is high the reserve in *T* is rapidly used up, the spring drives the piston *J* to the end of its stroke, and the cam *C* produces a complete aspiration of gasoline. Inversely, the movement of the piston is small if consumption is low.

#### Revolutions and Fuel Consumption Shown Concurrently.

This arrangement gives at one and the same time the number of revolutions made by the motor and the amount of fuel consumed by it. On the shaft of the cam *C* is mounted a pinion *B*, which, operating through *E*, drives an ordinary counter *F*; this registers the number of motor revolutions.

On a certain length of the connecting rod, corresponding to the maximum stroke, is a toothed rack to which is connected a pinion *K* carrying two ratchets operating in one direction only. On the intake stroke of the piston the pinion turns from left to right and the ratchets drive the wheel *M*, within which they are mounted, thus operating the counter *N*. Naturally this wheel is only carried round a distance corresponding exactly to the movement of the rack; if the aspiration is small, the wheel *M* only revolves a few teeth,

is more favorable to moderate fuel consumption than is low speed. One motor on which it was tried was found to consume double the amount of gasoline when running at 500 revolutions per minute without load than when driving the car under normal conditions. If the constructor had been able to obtain use of the apparatus when testing his engine he would certainly have made changes. The loss of gasoline through leakage is readily determined by the use of the apparatus. The results obtained over ordinary roads can be noted and compared with the consumption of the engine at any future time.

#### How the Simple Theory Is Modified in Practice.

For practical purposes it has been necessary to make several departures from the simple sketch shown and referred to. Thus, the spring *I* is replaced by two long springs at each end of a balance arm, drawing the piston towards the left. A comparison of the two designs, Figs. 1 and 4, will show in what respects the simple principle has had to be modified to obtain a practical application. The eccentric *B* has been re-

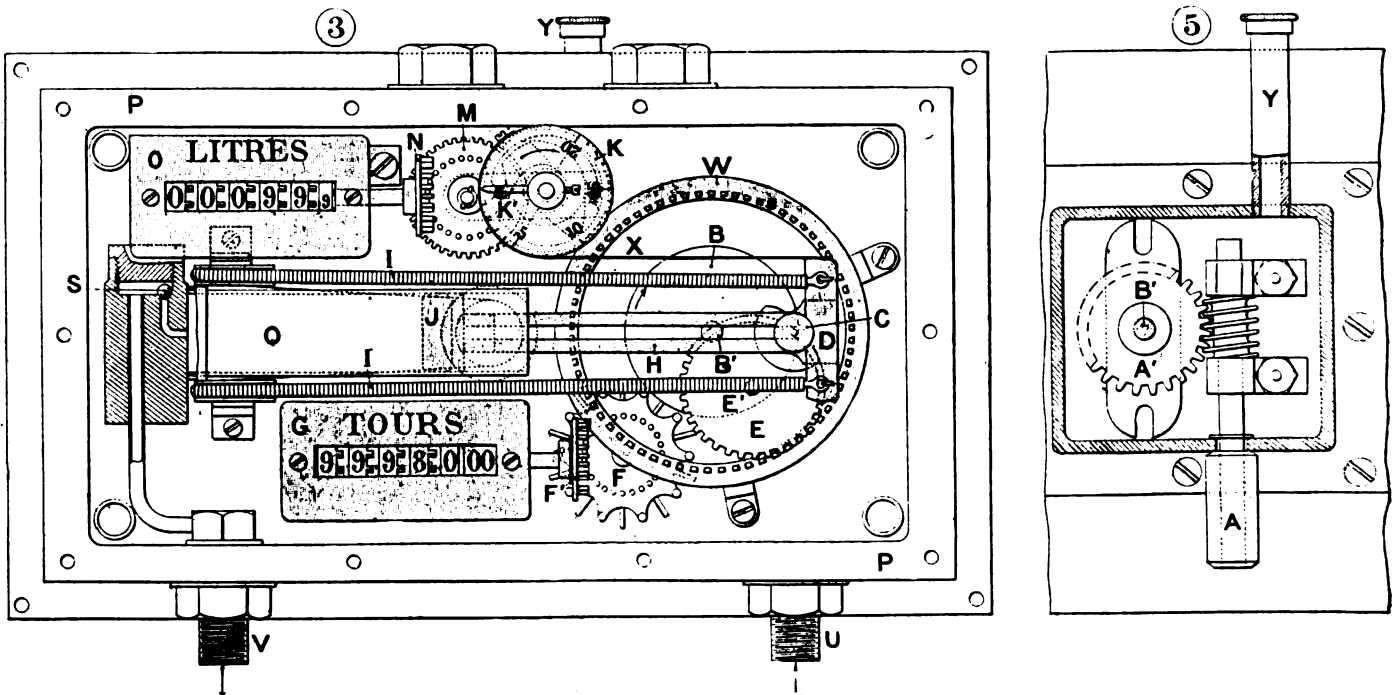

FIG. 4.—Elevation of the mechanism of the gasoline meter. This will be better understood by comparing it with Fig. 1, indicator letters being the same on the two. Fig. 1 shows the elementary simplicity of the apparatus; Fig. 4 represents it as it is actually constructed.

and the counter only registers a small movement. When the rack moves towards the left (outlet) the pinion *K* turns from left to right with its ratchets, but the wheel *M*, and in consequence the counter *N*, are not disturbed. The amount of fuel consumed, which corresponds exactly to the movement of the connecting rod of the piston, as explained, is obtained in larger or smaller fractions, the volumes consumed being totalized by the counter.

It should be noted that there are two separate indicators, one registering the number of liters consumed and the other the number of revolutions of the motor. By means of these it is possible to read the consumption of the engine with the throttle at varying positions, the motor running free, or on various gears, etc. A glance at the sketch will show that the design of the apparatus is such that at every hundred revolutions a pointer moving over a dial *K* registers separately the amount consumed during the last hundred revolutions. The value of this hardly needs amplification. To take but a few examples, it was shown by the apparatus that the consumption of a motor in town work was considerably higher than in open country. Other things being equal, high speed

placed by a disc carrying a short shaft *E'* on which the wheel *E* revolves. The pinion *E* is twice as small as the fixed tooth wheel *W*, and disengages from this latter to allow the movement of the piston obtained by the eccentric.

The disc *W* is driven by the shaft *B'* operated by a worm gear through a flexible shaft connected up to the crankshaft of the motor, the camshaft, or the pump shaft, as may be most convenient. The entire mechanism is contained in a metallic case with a strong glass front, every part thus being visible from the outside. To the connecting arm carrying the two springs is attached a metallic band *X*, which drives the drum *K* in one direction only. A small spring maintains the band stretched to its limit; the arrangement within the drum is the simple one of a ratchet and free wheel. It is by means of this dial *K* that the consumption per liters per hour can be obtained instantly. If, for instance, at the moment of aspiration the indicator marks the figure 20, the driver knows that, providing the same conditions are observed for one hour, the consumption of the motor will be 20 liters.

Under the gasoline meter is installed a two-way cock by means of which the flow can be opened or cut off.

## LETTERS INTERESTING AND INSTRUCTIVE

### ABOUT RETIMING A MAGNETO.

Editor THE AUTOMOBILE:

[1,133.]—Will you kindly give me some information as to how to time a Bosch high-tension magneto that has been removed from a four-cylinder engine, without first having marked the gears or couplings, whichever may be used for driving it?

Saratoga Spa, N. Y.

A FRIEND.

Open the petcock of the forward cylinder, or take out the spark plug, if located in the head, so that the position of the piston may be noted. This may be done by taking a piece of small gauge stiff wire and inserting it in the hole thus made. Turn the engine over until the wire ceases to drop and starts to rise again. This will give the lower dead center and the upper dead center may be found in the same way. Take off the valve covers of the same cylinder and, by noting the action of the valves, turn the engine over slowly until it is brought to a point where the piston of the first cylinder, counting from the radiator rearward, is at the upper dead center and about to start downward on a power stroke. This will be the case where both the valves have remained closed during the last upstroke, corresponding to the compression.

Uncover the contact breaker as well as the distributor of the magneto, and turn the shaft of the latter by hand until the armature is in a position where the contact breaker has just opened the circuit to fire cylinder number one. Mesh the driving and driven gears of the magneto drive as closely as possible at this point. It may be found necessary to move them half a tooth one way or the other to effect this, and this should be done with the magneto gear. The allowance for advancing and retarding the time of circuit opening in the latter will compensate for this. Reassemble and test the engine in this position. If it is found that there is insufficient allowance for timing the spark one way or the other with the coupling in this position, disconnect the magneto and move ahead or back one tooth and try again. For running under normal conditions the spark should occur a short time before the piston reaches the upper dead center prior to a power stroke.

### VALUE OF LONG OR SHORT STROKE RODS.

Editor THE AUTOMOBILE:

[1,134.]—Please advise me if the wear on connecting rods in a short stroke engine is greater than in one with a long stroke. A practical repair man, disinterested in the make of any automobile, claims that where there is a long connecting rod, the angle is not so acute, which prevents sidewise thrusts on the connection at the crankshaft, thus preventing the wear and tear at this point. Theoretically this seems to be correct, but does it apply practically? The Reo makes a long stroke engine, the Maxwell short stroke, and by inquiry I learn that the latter owners have no more connecting rod adjustment to do than the former. Can you explain where above mechanic's views are wrong in columns of "Letters Interesting and Instructive?"

L. C. BURGARD.

Columbia, Tenn.

The mechanic is quite correct in stating that there is less strain imposed on the connecting rod of a long stroke motor than where the latter is very short, owing to the angle at which the latter operates and the fact that you do not find any great difference in a single instance is hardly sufficient to disprove this. It is correct both theoretically and practically, but the difference between what is a "long" and a "short" stroke in the case of an automobile motor is slight—so much so that the corresponding difference in the service rendered is practically a negligible quantity. The longer stroke also imposes less side thrust on the cylinder wall, this being overcome to a great extent in many instances by offsetting the cylinders on the crankshaft center.

### HOW TO TEST VIBRATOR COILS.

Editor THE AUTOMOBILE:

[1,135.]—Referring to letter No. 1,132, in which the writer suggests that 1-4 ampere is ample to get good results from dry batteries, would like to know how to make this test. I have a four-cylinder Winton and always carry with me a pocket ammeter. In adjusting the buzzer on the coil I have always simply examined it to see if it would vibrate, and nothing more. Can I with a pocket ammeter regulate the coil so that I will use only 1-4 ampere, and where do I connect the ammeter to make this test? Must the connection be made with the buzzer on the coil, or where?

Newark, N. J.

F. H. THOMPSON.

The ammeter should be connected directly in the primary circuit, that is, the wire leading from the battery to the coil to be tested so that all the current employed will pass through it. To do this, disconnect the battery wire from the coil and connect it to one of the terminals of the instrument; the second terminal of the latter should then be connected to the coil so that the ammeter practically forms a link in the circuit between the battery and the coil. Start the engine and run it at about normal speed. Then adjust the vibrator until the current consumption is reduced as low as it possibly can be, consistent with good running of the engine. However, the ordinary ammeter, or battery tester, is not well adapted for making such a test, as it is calibrated to read up to 25 to 30 amperes and, as a consequence, the divisions are very small. Special instruments are on the market for this purpose, their scales only reading to 3 amperes by tenths. Owing to the fluctuation of the needle it would be practically impossible to adjust a coil to take not more than .25 ampere with the ordinary battery tester, as the needle will swing over several divisions of the dial, amounting to as many amperes, every time the current passes.

### IS THE IGNITION TIMING DERANGED?

Editor THE AUTOMOBILE:

[1,136.]—Please inform me how you could connect the ground wire and positive wire so as to make a magneto run. Does it call for a two point switch? The magneto is connected to the motor.

I also wish to know why I can advance throttle and spark the full length of the quadrant when clutch is disengaged without a knock, but running on the level or on a hill with the spark half way advanced, I can at no time when the clutch is engaged advance the throttle of not over quarter way without getting a knock. Even doing this I get a knock going down. I know it is not in the bearings, or because of carbon, as all have been cleaned. I thought perhaps the gearing of the car was too high. Please give me all the information you can.

F. R. B.

The data you give concerning your magneto is very ambiguous, but we presume it to be of the low-tension type, as you speak of a "positive wire," by which we presume you mean one taken from the generator to the ignitors. There is generally no outside ground connection on a magneto, whether low or high tension. The winding of the armature is grounded on the core of the latter, so that fastening the magneto in place on the motor grounds it without further attention. By "connected to the motor" we presume you mean a mechanical connection, but are not certain; in fact, find it impossible to get at just what you wish to learn and must ask for further and more detailed particulars.

Regarding your second query, if you are quite certain that the knock is not due to the bearings, which cannot be presumed without a close examination, particularly in view of the fact that the engine will run quietly when idle, it would appear that the ignition timing may be deranged. That is, the actual occurrence of the spark in the cylinder takes place at a point greatly in advance of what is represented by the position of the spark-advancing lever, so that the result is

equivalent to that of preignition. That is, going on the assumption that neither loose bearings nor carbon deposits are the cause. Your suggestion that the gearing may be too high, in turn suggests the question, Has the car always given this trouble, or is it something of recent origin? An inherent fault such as this would be more than likely to show itself earlier in the use of a car. Investigate the ignition timing, also the bearings, and see if one or the other is not faulty.

### HOW TO MAKE A HOME-MADE VALVE-GRINDER.

Editor THE AUTOMOBILE:

[1,137.]—As I am very much interested in your "Letters Interesting and Instructive," I wish to do my share in making it interesting to others. The enclosed cut will speak for itself. It is a home-made valve-grinder. I made it from an old brace such as is used by any carpenter. I straightened out the crank part and then cut it off about 8 inches long, heated it and made a regular screwdriver point on it; then, forcing the hand off the top of the rod, I bored a hole in a piece of pitchfork hand and slipped it on the rod, pinned it fast by a steel pin, after boring an eighth of an inch hole clear through wood and steel rod. I then took a stout, heavy cord and tied a knot in it and then to the pin, gave it several turns around the wood and fastened a weight to the lower end and took hold of the upper. In this way I can seesaw and grind a valve in good shape. In case one does

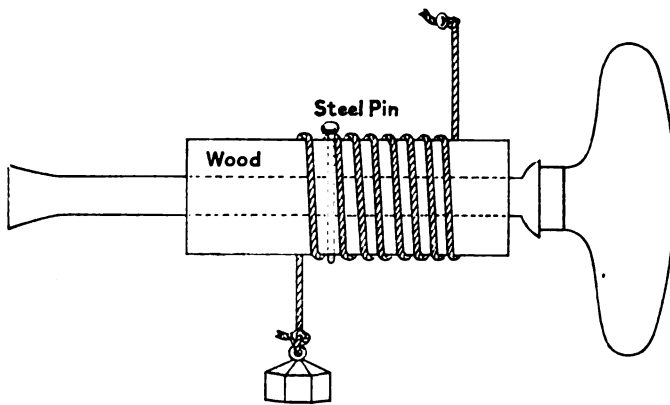

DETAILS OF THE HOME-MADE VALVE-GRINDER.

not have a horizontal engine and the valves are vertical, one can work it with both hands or it can be worked without the cord. I find this one of the handiest tools I have in my set, which I always keep in the auto tool box. In my motor I have an opposed air-cooled engine, laying horizontal under the seat; it is a 4 by 4, and the fan flywheel, instead of driving the air from the engine, sucks the hot air away from the engine. Is this the best plan? Seems to me if the engine would drive the hot air off the cylinders instead it would not heat as quick. V. R. LANE.  
West Liberty, Ia.

The sole object of the fan is to induce a draught of air over the heated portions of the engine and whether it does this in one way or another is immaterial. In fact, on many present-day cars, both methods that you speak of are employed, the fan behind the radiator drawing cold air through the latter and throwing it on the engine, while the flywheel fan draws the warm air away from the engine.

### FIGURING THE RATIO OF PLANETARY GEARS.

Editor THE AUTOMOBILE:

[1,138.]—Will you kindly tell me in your next issue what the ratio is between the low speed and direct drive in a planetary transmission as follows: Driving gear on crankshaft 20 teeth, pinions on spider or driving sleeves, 12 teeth, internal gear 44 teeth. Now, when the internal gear is held stationary, how many revolutions does spider or driving sleeve make to every 100 revolutions, and what is the rule for determining the above?  
Calumet, Mich. GRANVILLE BENSON.

Let  $G$  = driving gear on the shaft = 20 teeth;  $I$  = internal gear = 44 teeth;  $P$  = pinions = 12 teeth. With the internal gear  $I$  held and the central gear  $G$  running as a driver to reduce the speed, the planets or pinions  $P$  turning on studs in

the spider, it will be evident that  $G$  will have to make one more complete turn to drive the planet round its orbit than the direct relation between the driving gear and the internal gears  $G$  and  $I$ . Thus with  $G$  half the size of  $I$ , the ratio would be 3 to 1, and with the figures you supply, it is 3.2 to 1. In the same manner, when the planet is made the driver, it will give the central gear one more turn than the ratio between the internal gear and the sun or central gear. The easiest manner to figure this is to divide the internal gear by the central gear and add one, which will give the low-speed ratio in this case. There are probably a dozen or more different methods of calculating these ratios, many of them of a highly complicated nature, but where the number of teeth in the various gears are evenly divisible, they may be figured without any great difficulty by adding or deducting one turn, according to which gear happens to drive.

### FIGURING THE POWER OF TWO-CYCLE ENGINES.

Editor THE AUTOMOBILE:

[1,139.]—Will you please send me the formula for figuring the horsepower of a two-cycle engine?  
Chicago, Ill. A. J. OESTERBECK.

About as simple a formula as any is the following,  
$$\frac{D^2 \times L \times R \times N}{18,000} = \text{Horsepower, in which } D \text{ is the diameter of}$$

the cylinder, or bore;  $L$ , the length of the stroke in inches;  $R$ , the number of revolutions per minute, and  $N$ , the number of cylinders, while the denominator is an arbitrary quantity based on the use of gasoline as a fuel. There are numerous other ways of figuring the power of a two-cycle engine, though the foregoing will be found as simple as any, and likewise about as accurate as any of the others. The brake test is really the only definite means of knowing what an engine's capacity is. The only difference in calculating the indicated horsepower of a two-cycle engine, as compared with a four, is to allow for the extra power impulse.

### MORE IN AID OF MR. WEBB.

Editor THE AUTOMOBILE:

[1,140.]—In letter No. 1,117, J. S. Webb asks for information in regard to a Ford runabout. Last summer a car was pulled into the garage where I was employed; it wouldn't go. The motor acted as Mr. Webb's did, and they could not make it run. The first thing I did was to test the coil, and found that one of the vibrators was stuck in such a manner as to short-circuit the current and keep the other buzzers from going. It would fire on the stuck vibrator, but not good and strong, as it should. After this was fixed it would stop the whole engine on high speed, and it would stick partially and cause the motor to miss, as if it was faulty carburetion. Finally, by changing the units and putting in new platinum, the difficulty was overcome.

Would you kindly advise me through your columns if there is a technical school for learning automobile engineering as you would learn any other branch of engineering?  
Roselle, Ill. E. A. MARTENS.

The New York School of Automobile Engineers, located at 146 West Fifty-sixth street, New York, offers such a course as you inquire about.

### USING A VOLTMETER TO TEST CELLS.

Editor THE AUTOMOBILE:

[1,141.]—I made a mistake in my query. Is a voltmeter as hard on batteries as an ammeter when testing?  
Warren, Mass. LOWELL ELLIS.

Owing to its high resistance, a voltmeter does not run a cell down in the same manner as an ammeter, but testing dry cells with a voltmeter gives but little indication of their condition, as a cell may show practically full voltage and still be all exhausted. The voltmeter, however, should always be employed in connection with storage batteries; in fact, it is dangerous to use an ammeter on a fully charged accumulator and is apt to result disastrously to both the ammeter and the accumulator.

**CAN ANYONE SUPPLY THIS INFORMATION?**

Editor THE AUTOMOBILE:

[1.142.]—I have a runabout which is a Buckmobile. I bought it second hand. I cannot find out where it is made, nor do I know, but I think the firm that made them is out of business. Will you, if you can, give me the address of the firm if it exists, and if not, who could I address that could give me information about it?  
J. H. TOWNSEND.

Danbury, Conn.

We do not know the address and are under the impression that the firm is out of business. Probably some of our subscribers can furnish more definite information on the subject.

**TO USE GAS IN A GASOLINE MOTOR.**

Editor THE AUTOMOBILE:

[1.143.]—I would like to have you advise me what changes have to be made in the ordinary gasoline engine to use illuminating gas as fuel.  
T. F. W.

Providence, R. I.

It is only necessary to remove the carbureter and connect the engine to the gas supply through the intermediary of a gas-mixing valve, which can be obtained from any supply house. The function of this valve is to mix the gas and air in the proper proportions to obtain a suitable fuel.

**VIEWS OF A TIRE EXPERT ON REPAIRS.**

Editor THE AUTOMOBILE:

[1.144.]—In your issue of January 23 I notice that you have a subscriber who wishes to know the best cure for a blow-out in an automobile tire. As I am considered an expert on tire works I have decided to give you my opinion. There is only one way of curing a section or blow-out, and that is in a steam vulcanizer in a sectional mold. That is dry heat, created by steam, and the heats of such cures depends entirely on the stocks used on repairs. When you put a section in a tire and place it on a rim, and wrap it and put it into a steam kettle, you certainly overcure the old rubber and make it soft, and when it does dry, it will harden and crack. It is also liable to separate the fabrics. It is all right to put a retreaded tire through the kettle, as that is the simplest method. Of course, some tires are molded in a complete mold.

A section or blow-out repaired properly with good stock and cured properly with a strong pressure on air bag in the proper mold cannot be equalled in strength, looks, or service by a wrapped steam cure.

I am doing repair work for the best house in Boston and have very rarely a section come back that has done less than 500 miles and in many cases over 1,000 miles. I cure all my casings in an automobile tire vulcanizer with section molds. Only yesterday I cured fifteen sections, and they were all perfect and hard to beat for looks or strength. I have made tires in two factories and worked in three. Have been repairing bicycle single tubes, automobile tires, and the up-to-date tires of all makes and descriptions, and want to see the tire I cannot repair if it is profitable to the owner of such tire, since 1896—about eleven years—and I think my opinion is worth considering.

My ideas of repairing are my own and cannot be beat like other tire men. I keep them to myself because it makes my business better. I pass judgment on about 3,000 tires in a season.

Boston, Mass.

JAMES P. BROPHY.

**IN REBUTTAL FROM MR. POOLE.**

Editor THE AUTOMOBILE:

[1.145.]—As Mr. Fay's reply (No. 1,124) to my comment (No. 1,106) on his article consists chiefly of quibbling, it is rather difficult to continue the discussion in good temper. Mr. Fay originally made the broad general statement that the mixture drawn in by a gasoline engine at high speed is poorer than that drawn in at low speed; he did not say that this was true if the carbureter had an auxiliary air valve poorly adjusted; he stated it as a general proposition without reference to the type of carbureter used. He evidently realizes now that his statement was erroneous and tries to take refuge behind the fact that his article contained an illustration of a carbureter with an auxiliary air valve, to which no reference was made in connection with the criticised statement. This not only is unfair, but it does not make his original statement true as it stands.

The question of scavenging is a difficult one to discuss. I can only say that experiments made by myself and others have shown that, within the limits of rational engine speed, better scavenging is obtained at high than at low speeds, provided the exhaust valve is not too small for the engine. With a properly proportioned

exhaust valve, increased speed will, by reason of the increased "suction" effect of the outgoing exhaust gases, give better scavenging up to the speed where the increased friction of the exhaust passages just neutralizes the increased suction effect; beyond this point, the scavenging effect decreases rapidly with increased speed for which the engine is adapted. Of course, I am referring to engines working on the four-stroke cycle and taking practically the same quantity and quality of mixture per cycle at all speeds. In making a general statement of any kind it is usually understood that all conditions remain fixed except those affected by the statement.

Mr. Fay's quibble over the word "combust" is unwarranted. He deliberately clouds the discussion by talking about "combustion" and "combustible," to which terms I did not refer at all, and indulges in some irony about the age of dictionaries. The facts in the case are these: Mr. Fay used the verb "to combust" in the sense of "to burn"; the verb "to combust" means to cause popular clamor or to excite the public mind, and no matter how ancient Mr. Fay's preferred dictionary, he will find in it that definition, in substance; the definitions of "combustion" and "combustible" have nothing to do with the definition of "to combust" and were not referred to in my letter.  
CECIL P. POOLE.

New York City.

**INTERESTING EXPERIENCE AND INFORMATION.**

Editor THE AUTOMOBILE:

[1.146.]—In reading over your "Letters Interesting and Instructive" in the current issue, I felt inspired to write the following:

Regarding letter No. 1,113. Your correspondent might find considerable trouble, at times, from the timer binding posts contacting with pieces of the crankcase, transmission, etc. The timer is tucked away carefully in a cute little nest under the dash between the planetary change gear and engine frame. I often had this trouble. Maybe I should have said wires, instead of binding posts grounding.

Concerning the carbureter trouble. Your correspondent speaks of "dash regulation," which suggests the Holley carbureter. I have a Holley on my Model N; it has dash control, and I have a trouble similar to the one described in your paper. Mine was caused by the cork float absorbing gasoline and changing the level in the air passage.

C. S. G. states, in letter No. 1,128, that for 6,000 miles his car only cost him 4 1-2 cents per mile to operate. Repairs alone cost me almost that. I got my car last June, and started keeping records July 1. On December 1 I totaled things up. In that time, five months, I had driven same 3,500 miles, used 215 gallons of gasoline, paid out \$125.70 for repairs and replacements, of which \$22.30 went for dry cells and \$22.35 for springs, new and repaired. I got wise and put in a Holley magneto and stopped all ignition expenses thereby. I used 22 gallons of lubricating oil, getting only about 160 miles out of a gallon, and I declare I don't see how anyone can possibly get 500 miles with one of these cars. Expense per mile sums up like this:

Replacements and repairs.....	.358 per mile
Cleaning and garage rent.....	.068 " "
Gasoline (24 1-2 cents per gallon).....	.150 " "
Lubricating oil .....	.050 " "
Tires .....	.100 " "
	<hr/>
	.726 per mile

Since I have had the car, I have spent a little over \$200 on improvements, which covered lamps, magneto, carbureter, top, etc. Have a very trying road to travel, 10.1 miles each way, over natural Colorado roads, good a short time, and full of chuck holes most of the time. Make this trip nearly every day; are building a mill at the terminus, concrete. Drive a good bit besides this, for pleasure.

The machine has done very well indeed, and while I have had villainous carbureter and ignition troubles, before I tore out the crude equipment that came with the car, have never failed to make my trips on schedule, 40 minutes. When the road is heavy with mud, as it is very rarely, probably has been for two weeks altogether in the time mentioned, it takes seven minutes longer to make the trip. However, the car is now pretty well racked; every rivet is loose from the eternal jarring.  
T. B. RENNELL.

Florence, Col.

**TO THE SUPPORT OF MR. FAY'S VIEWS.**

Editor THE AUTOMOBILE:

[1.147.]—As Mr. Fay says, the needle valve is a makeshift, and should not be tolerated on any well designed car, for reasons as follows:

It complicates the carbureter by making extra parts. It is something for the novice to fool with when he wants "to improve the running of his car." It destroys the true nozzle effect. Its construction is such that it gives a very small opening all around itself—the least bit of dirt, corrosion, water or in fact almost any-



thing is prevented from passing. It is not at all essential to the operation of the carburetor.

Only last week, having a carburetor to adjust on a two-cylinder, 4x4 3-4-inch engine, I made an experiment as follows: The carburetor was adjusted by the needle valve, float and air valve, to give the best results and the performance of the car noted. Three nozzles were then made with fixed openings, Nos. 54, 57 and 60 drills being used. Nos. 54 and 57 were tried and found too large. No. 60 was then tried and found to give fair results. No. 54 was plugged with solder and reamed out slightly smaller than No. 60. This gave as much power and speed as with the needle valve, without any of its faults, besides being able to run the car at a very low speed with little or no vibration, an impossibility before the change was made. The principal reason for making the change was the constant plugging up of the nozzle on account of the very small opening around the needle valve, obliging the driver to get out and open the valve, to wash the obstruction out. This same trouble was on a number of cars the writer has had to do with.

The needle valve seems to be a feature of the cheaper American cars, being very seldom used on the high grade cars, and practically not at all on the foreign cars.

If as Mr. Poole says, the scavenging effect is better and the timing of the spark is as accurate, the engine should deliver its maximum power at its highest speed, which is very seldom the case.

South Easton, Mass.

C. T. BATES.

**MORE IN SUPPORT OF THE "SIX."**

Editor THE AUTOMOBILE:

[1,148].—I beg leave to take up the cudgels in the four-cylinder versus six-cylinder controversy. It seems to me that many of the articles lately appearing in the various trade papers and magazines are written either by people who are ignorant of the actual properties of the six-cylinder engine, or else know nothing of the practical mechanics of the gasoline engine in general.

If the ones who are always howling about the sixes being no better than the fours would only take a little ride in a six, they would soon change their minds. The six has less vibration than

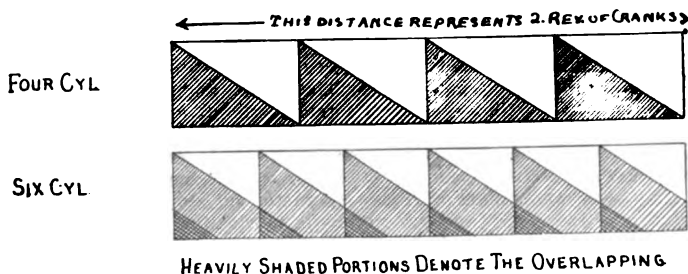

GRAPHIC COMPARISON OF FOUR AND SIX-CYLINDER.

the four, and no amount of theory can disprove this. The six furnishes stronger driving power than the four at all speeds, is more silent, has more perfect carburetion, and is as simple to take care of as a four. Anyone doubting these facts would do well to investigate the six thoroughly. In regard to the comparative simplicity of the two types of motor there seems to be a good bit of disagreement. For instance: "Fifty per cent. more ignition apparatus," shouts one manufacturer, while another facetiously replies that "if a four-cylinder motor requires one magneto, we hasten to assure an innocent and unsuspecting public that a six-cylinder motor does not require one and a half magnetos." Take the magneto as a concrete example; is the six magneto 50 per cent. more complicated than the four? Not by quite some. It has two additional contact points, with no more moving parts, and that is all. Again, it seems perfectly natural that an engine maintaining a continuous suction in the carburetor will get a more perfect mixture than one that keeps up only a fitful and constantly varying suction.

Some of the authorities (?) in the automobile world seem to lose sight of the original object of their argument in their anxiety to outdo each other in this so-called "nature faking." Then, again, there seem to be others who bring in arguments that have no foundation in fact, and palm them off as convincing. Two gentlemen, for instance, claim the remarkable powers of producing constant torque by means of carburetors and flywheels respectively. I cannot help but feel sure that there is a fortune awaiting both of these gentlemen when they succeed in doing what they claim to be able to do. No matter how heavy the flywheel, at every impulse of the piston it is going to receive a certain amount of acceleration, and during the succeeding idle stroke (in a single cylinder, for example) it is going to lose a certain amount of its momentum. That the torque of such an engine should be called continuous

seems queer, to say the least. Also, I would like very much to see the carburetor that will make the power strokes overlap as in a six. In order to show this overlapping graphically I am enclosing a rough drawing which may serve the purpose.

While I am at it, I would like to take sides with Mr. Fay in his discussion on carburetors. As he says, when a carburetor is especially designed for the engine to which it is attached, and if it takes its air supply through a perforated sleeve surrounding the exhaust pipe, the quality of the air entering the carburetor remains so nearly constant that a non-adjustable spray nozzle will give most excellent results. But if the carburetor has a plain cold air supply, absolutely unheated, every change in the temperature and humidity of the air will affect the mixture to an appreciable extent; a fault that can be most quickly and easily remedied by changing the amount of gasoline flowing through the nozzle. It would seem, therefore, that an adjustable nozzle would be best in such cases. I may add that these last facts concerning carburetors are taken from actual personal experience.

GEORGE SAUTTER.

Newark, N. J.

**FROM AN OHIOAN ABOUT BLIND DRIVERS.**

Editor THE AUTOMOBILE:

[1,149].—I have read with considerable interest in your issue of January 23, the account concerning a bill which is soon to be up before the Ohio Legislature, and gotten up by the Hon. Elijah Hill, to make it lawful for a blind man to operate an automobile in the State of Ohio. Living in Ohio myself, I am, of course, very much interested, else I would not have given the article a second thought. There has been, from time to time, various schemes brought forth for the purpose of drawing revenue from the autoist, but this one seems to be about the cap sheaf of them all. It would seem to me that any person whose vision is in any way impaired would drive in a very careful manner or else quit the game entirely, if only for his own safety.

This bill not only hits the owner, but the chauffeur as well, who must dig up five of his hard-earned plunks to help maintain this soft, specially created \$1,500 job, and all he has to show for his money is a paper which tells him he can see just as good as he could before.

I sincerely hope that when the bill comes up it will be killed dead, for I and, I think, a good many other Buckeye autoists are tired of constantly paying out five dollars for this and five dollars for that. However, my views may be wrong or prejudiced; if so, I am willing to stand corrected.

R. J. THOMPSON.

Orlando, Fla.

**THE TROUBLE IS IN THE TIMER.**

Editor THE AUTOMOBILE:

[1,150].—Some three or four issues ago, in Letters Interesting and Instructive, I noticed a communication from a man who owned a Maxwell car. He had experienced trouble with a motor missing, particularly at high speed, and he believed that the trouble was in the carburetor.

The writer is very familiar with the Maxwell, and I am positive that the trouble was not in the carburetor. As a matter of fact, the Maxwell car, though not automatic, is simple, and not liable to get out of order. I believe the trouble in this case was in the commutator. The tension is controlled by a small spring. This frequently loses its elasticity, so that when the motor is speeded up the spring is not able to return the arms into position in time to make the next contact.

If your reader will put on a stiffer spring, or attach two of these springs instead of one, I think he will have entirely eliminated the trouble. Of course, the trouble may also have been with the contact arms, as well as the cam being badly worn. If this is the case, it is a very inexpensive matter to replace with new contacts.

New York City.

H. A. GRANT, M.E.

**IN AID OF A FORD OWNER.**

Editor THE AUTOMOBILE:

[1,151].—In your issue of January 23 I note the trouble had by J. S. Webb with his Ford runabout in regard to throttle action. Have had a like experience with my car and remedied it by draining the gasoline tank, in which I found a little water, which was the cause of the trouble. I think if Mr. Webb will do likewise and put in a new supply of clean gasoline it will eliminate the trouble.

J. C. JEKEL.

Independence, Ia.

**ROADS INFORMATION WANTED FROM GEORGIA.**

Editor THE AUTOMOBILE:

[1,152].—Kindly answer in the columns of your "Letters Interesting and Instructive" the following: Are the roads in Southern Georgia, near Waycross, too sandy to drive an automobile on?

Toledo, O.

H. L. Y.

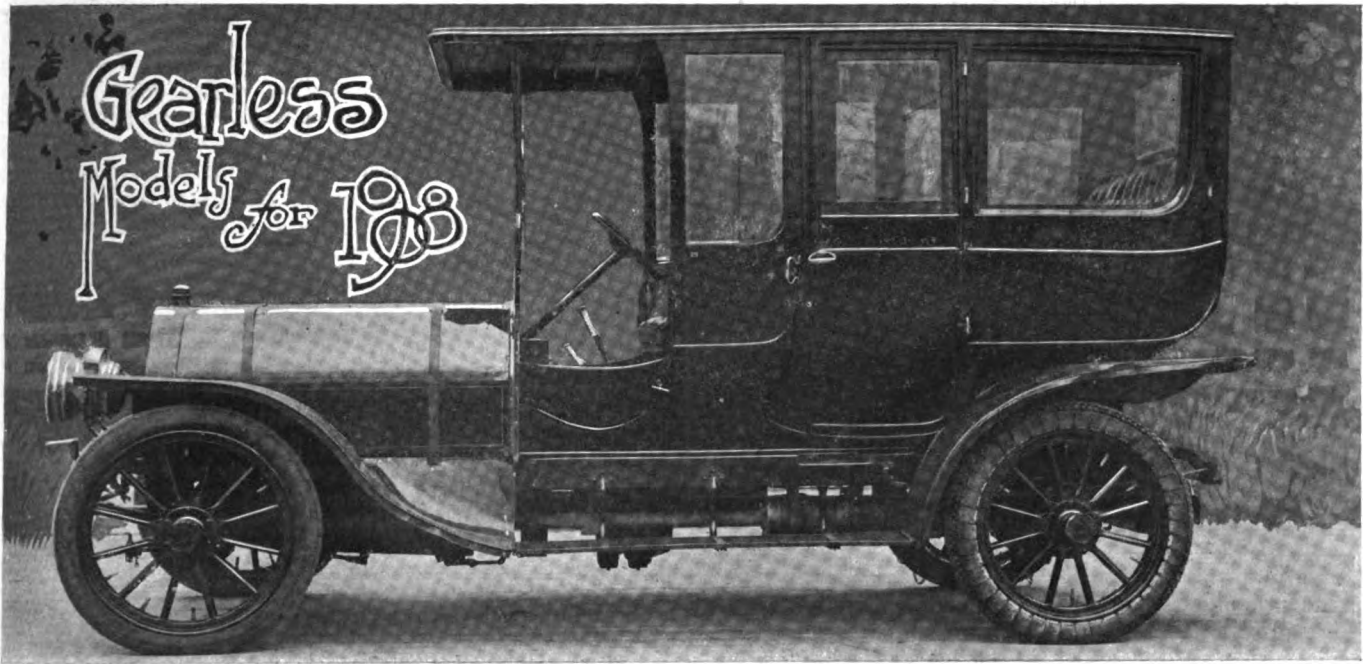

THE SIX-CYLINDER, 75-HORSEPOWER GEARLESS LIMOUSINE FOR 1908.

THOUGH the line of Gearless cars for 1908 will comprise three distinct models, doubtless the makers—the Gearless Transmission Company, Rochester, N. Y., will devote a large part of their time and attention to the production of their Model 60, which is a convertible five or seven-passenger touring car. The cylinders of the motor of this model measure 5 inches bore by 5 3/4-inch stroke and are offset on the crankshaft center. They are cast in pairs and the valves are all placed on the same side and are operated from a common camshaft placed on the left hand side of the motor. The crankshaft is turned from a solid billet of high-carbon steel and is finished by grinding. It is supported on three liberal-sized bearings of Parson's white brass. The valves themselves are made of nickel-steel, and advantage has been taken of the method of valve arrangement to place all the auxiliaries of the motor on the right hand side, thus making them very accessible. The timer and magneto are both located at the rear, just forward of them is the carbureter, the intake pipes being led over the tops of the cylinders between the two pairs, thus making an extremely simple intake manifold, as will be evident from the valve side of the Model 60 motor, which is shown herewith.

Further forward on the same side is the mechanical force feed oiler, having eight individual leads, which are taken to the main bearings, the lubrication also being supplemented by splash in the crankcase. Dual ignition is provided, one system comprising a self-contained unit in the shape of a Bosch high-tension magneto, while the other consists of a standard four-unit

vibrator coil, low-tension timer and set of accumulators as a source of current supply. Independent spark plugs are employed for each system, those connected with the magneto being placed over the inlet valves, while those of the second system are placed over the exhaust valves.

The heavy car of the Gearless line is officially known as Model 75, and more familiarly as the Gearless "Great Six," which is equipped with a six-cylinder, 75-horsepower motor. The latter also forms the power plant of the "Gearless Greyhound," which is the third member of the line and is a high-power roadster model of the same type that made a name for itself by accompanying Weston at a four-mile-an-hour pace for almost 800 miles last November. In consequence the description of the motor of the touring car will apply to both. The cylinders measure 4 1/2-16-inch bore by 5 1/2-inch stroke. The valves are oppositely disposed and have their seats water-jacketed, while the carbureter is placed on the right hand side of the motor, a very simple type of manifold being employed. The Bosch high-tension magneto employed for ignition is also placed on the same side of the motor, two independent systems being employed as on the smaller motor. Simplicity and accessibility have been the aims of the designer throughout, the gears for operating the camshafts, timer, magneto and pump consisting of a steel pinion on the crankshaft, two bronze gears on the camshafts and steel pinions on the latter operating the magneto and pump. These gears are all housed in an aluminum casing and are run in oil, thus being free from grit and mud. The water

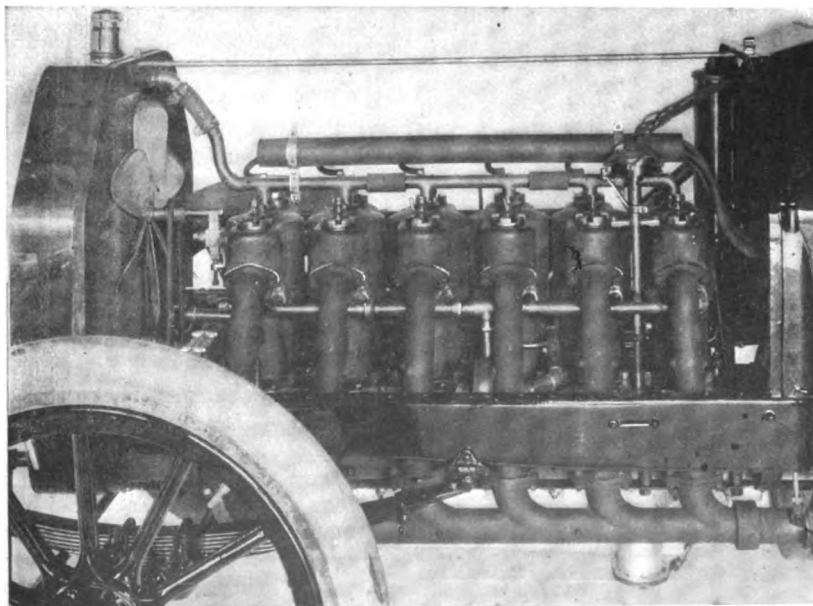

THE SIX-CYLINDER ENGINE, SHOWING ITS COMPACTNESS.

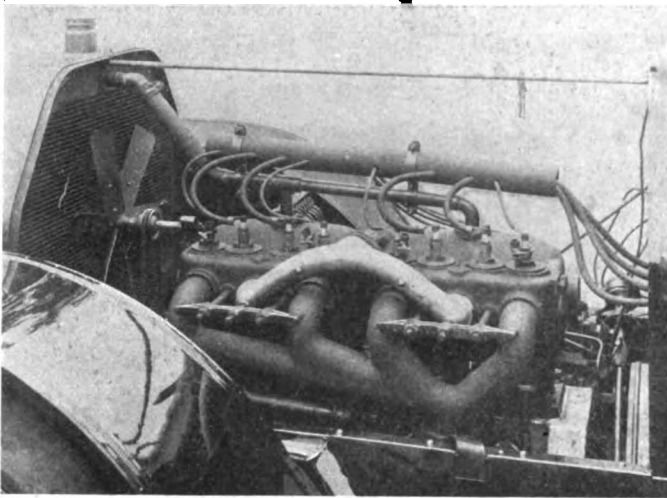

INTAKE SIDE OF THE MODEL 60 MOTOR

pump is of the centrifugal type and is permanently fastened to the engine.

To provide the necessary lubrication, a supply tank of oil is attached to the forward face of the dash, thus placing it in a position where the oil is constantly maintained at an even temperature in spite of weather conditions. From this tank individual tubes of liberal diameter lead directly to the main journals of the engine. Upon reaching the main bearings, which it serves to lubricate, it passes into holes drilled through the crankshaft, so that it also oils the crank-pins. This oil is drawn to the pins by centrifugal force and from there is thrown off in a fine spray, thus taking care of the piston and cylinder lubrication as well as that of the wrist-pins, combining in this manner all the advantages of the force feed and splash systems of lubrication. The surplus oil drips down from the interior of the motor and collects in a receptacle formed in the aluminum oil pan on the bottom of the motor, from which it flows to a pump by gravity and is automatically returned to the supply tank, first passing through a fine-mesh double screen which thoroughly cleans it.

The carburetor is of the multiple jet type, two independent jets being employed. It is employed in connection with a piston throttle and is water-jacketed, thus economizing fuel and facilitating the starting of the motor in cold weather. The advantages of this type of carburetor are that it practically embodies two carburetors in one, allowing the driver

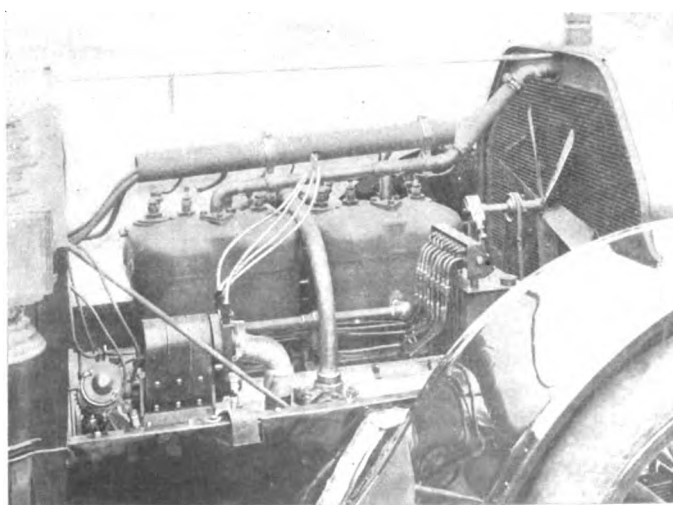

EXHAUST SIDE OF THE MODEL 60 MOTOR.

to handle the car at very low speeds with the throttle nearly closed, using the small carburetor only. By opening the throttle further, the larger carburetor comes into action automatically, thus supplying the engine with the proper quantity of fuel at different speeds. In this motor both spark plug terminate in the intake valve pocket, those of the magneto being placed at the side and at right angles to the cylinder, while the others are placed over the valves.

As is naturally to be supposed, while the motors of the Gearless cars are by no means lacking in distinctive features, interest centers in the change-speed gear from which the cars take their names. This is the patented gearless transmission, giving two speeds forward and reverse without the use of any gears, the high-speed being direct, in which the change-speed elements revolve together as a unit, with no internal friction nor rolling contact, the entire change-speed unit revolving together as a flywheel. It consists of six large special fiber rolls of conical shape revolving on and in an exterior and interior cone. These two cones coact with a sliding, double-faced, solid jaw clutch, which

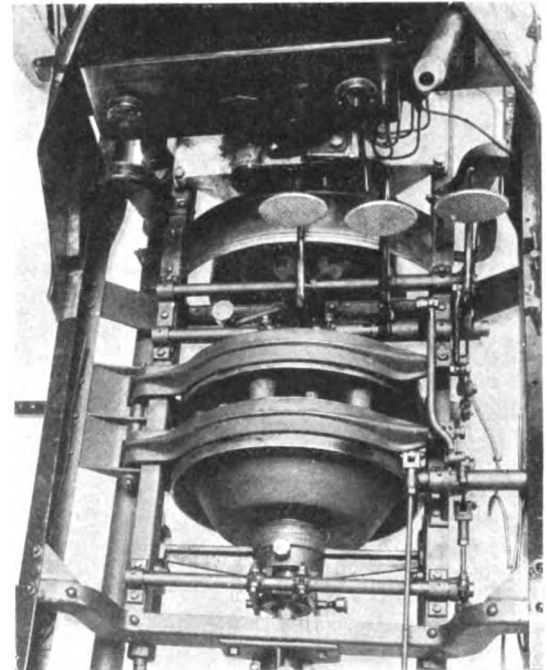

PLAN VIEW OF THE PATENTED GEARLESS TRANSMISSION.

is moved to the extreme forward position to give the low speed forward, and to the extreme rearward position to give the reverse. The internal cone is constantly pressed toward the external cone by means of a spring, so as to always insure "bite" enough to make the six cone rollers revolve without slipping in the low speed and reverse drives.

The Gearless transmission has the advantage of no change-gear friction whatever on the high speed, or direct drive, and rolling friction engagement in the low speed and reverse. The coned rollers are held laterally in a cage of large diameter and press against a gray iron cone made fast to the extension of the motor shaft. On their opposite faces they press against an internally faced cone, also of gray iron, and which is concentric with the propeller shaft of the car. The cone, roller and cup angles are such that the three elements roll together without any sliding, and hence without sliding friction, save in case of the slipping of the six rollers. To avoid the slipping of the rollers on the cone or in the cup a heavy spring pressure is applied to the cone cup to force it towards the driving cone, this pressure being sufficient to make it impossible for the motor to slide the roller surfaces on the cone or in the cup.



THE ELMORE "40"—THE TWO-CYCLE, FOUR-CYLINDER, "VALVELESS" CAR.

SO far as the substantial elements of their construction are concerned, the Elmore cars for 1908 are, well—the Elmore cars, for there are so many distinctive features about these consistent advocates of the two-cycle principle that nothing short of this suffices to describe them in a word. Numerous improvements have been made on the models for this year, chief of which has been the adoption of the Atwater-Kent spark generator as the means of ignition. The makers of the Elmore, the Elmore Manufacturing Company, Clyde, O., had this system under test for a long while prior to its formal adoption as a part of the standard equipment of their cars, and it showed up so strongly under the most rigorous of tests that its adoption was a foregone conclusion right from the start. The installation of this system on the 1908 Elmore cars has enabled the builders of the latter to achieve results in battery economy in the running of their cars that are almost incredible. As a matter of fact, every one of the carefully conducted tests made by the company showed that it was possible to get more than 2,000 miles' running out of a single set of six No. 6 dry cells, which is said to be many times greater than the average mileage obtainable with any other ignition system employing dry cells as the source of current supply.

The builders of the Elmore still retain the distinction of being the only makers turning out a three-cylinder car, this being their 24-horsepower model, known as the Elmore 30, which is listed both as a touring car, and a roadster, the chassis being the same in each case. The heavy car of the line is the Elmore 40, which is the four-cylinder type rated at 40 horsepower. Some of the changes in design made since the preceding year are the placing of the steering arm of the knuckle above the axle instead of below as in the former years, thus protecting it from injury when traveling over rocky roads or bad country. The hubs are now made extremely large, and the balls and hubs of the bearings are now made larger than was the case in last year's models. The belt drive of the oiler has been done away with in favor of a more positive and reliable drive. An im-

proved type of irreversible steering gear has been adopted, this being so constructed that all lost motion due to wearing of any of its parts can readily be compensated for by a simple adjustment. The power plant and all the elements of the transmission, such as the clutch, gear box, propeller shaft and rear-axle unit, have been brought practically into the same horizontal plane, thus minimizing the wear on the universal joints and giving a higher percentage of efficiency at the rear wheels. A honeycomb type of radiator constructed of seamless tubes has been adopted, thus eliminating the frequent trouble from leaks where soldered joints are employed.

Where the motor itself is concerned, lighter pistons are now used than was formerly the case, this being also true of the connecting rods, which are now one-piece drop-forgings. So far as the principle or operation of the motor is concerned, there have been no radical changes. It is the three-port, two-cycle, water-cooled type, the water being circulated by means of a gear-driven pump. The cylinder dimensions are 4 inches bore by 4 1-2 inch stroke, giving the car a speed range of from four to 45 miles an hour on the direct drive. On good level roads, these cars can attain a maximum speed of 55 miles an hour, while their flexibility is surprising. The makers lay special stress on the reliability of the lubrication employed on the Elmore cars, this taking the form of a mechanical force-feed oiler, which forces the oil into the intake pipe, thus insuring an even distribution of the lubricant to all of the cylinders. The carbureter is of the standard float-feed, automatic type, while, as already stated, an Atwater-Kent spark generator and dry cells take care of the essential of ignition.

The gear-set is of the sliding type working on the selective plan of operation by means of a single side lever, and provides three speeds forward and reverse, the final drive being by propeller shaft to the live rear axle. Shafts are fitted to the

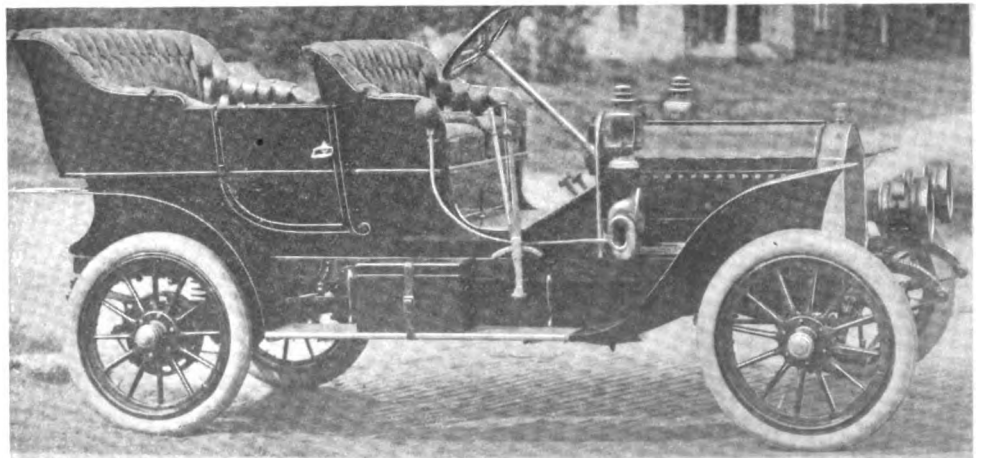

ONE OF THE FEW THREE-CYLINDER CARS MADE HERE—THE ELMORE "30."



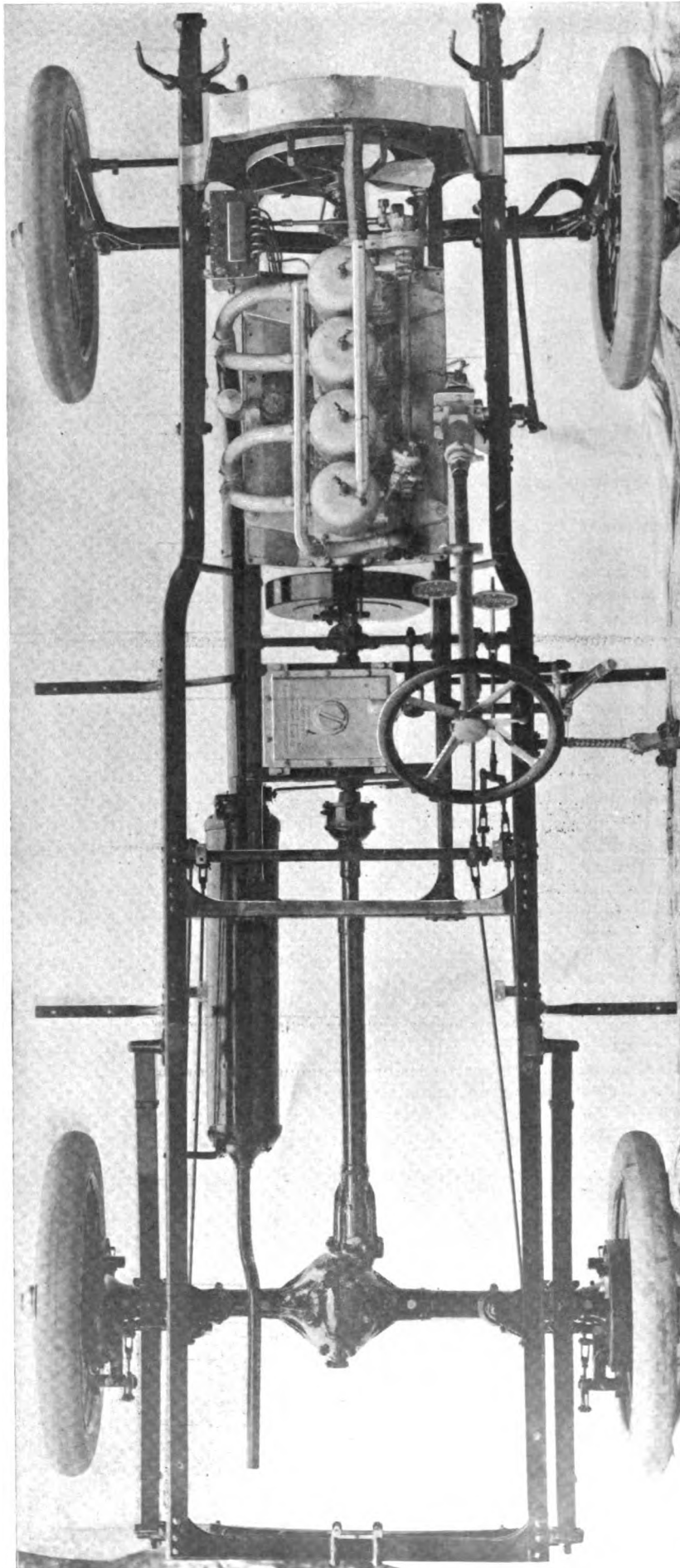

SHOWING THE GREAT SIMPLICITY OF THE ELMORE CHASSIS.

differential by means of squared ends and they are supported on Hyatt roller bearings and are provided with special thrust bearings. The front axle is a single-piece drop-forging with an extra heavy spindle supported on ball bearings, the inside bearings being equipped with 3-4-inch balls and the outside bearings with 5-8-inch balls. Suspension is by means of the standard type of semi-elliptic springs forward with a three-quarter platform type of suspension in the rear, supplemented by Sager auxiliary recoil springs on the rear axle as shock absorbers. The running gear consists of wooden artillery wheels fitted with Midgely universal rims, the tires fitted being of the same size all round in the case of both cars. On the Elmore 40 the tire equipment consists of 34 by 4-inch tires, and on the Elmore 30, and the roadster as well, of 32 by 3 1-2-inch tires. The brakes are centered in hubs on the driving wheels and are of the internal expanding and external contracting types. Their efficiency is very great, either set being capable of bringing the car to a halt within a short distance, only a slight pressure being required to cause the wheels to slide. The tread is standard on both cars, the wheel-base of the Elmore 30 being 104 inches, while that of its larger four-cylinder brother is 110 inches.

The dashboard of this car is made of mahogany, ornamented with a very heavy brass moulding so placed as to be free from vibration. The toe-board angle has been raised so as to make it much more comfortable than in the previous models. The gasoline tank has a capacity of 20 gallons of fuel, while the mechanical oiler holds six pints of lubricant. As the Elmore 40 will average 12 miles to the gallon of gasoline under any ordinary touring conditions, the radius of the car is very easy to keep in mind. The specifications of the Elmore 30 and the Elmore roadster are identical, while the design and construction of both are carried out in the same thorough manner that characterizes the larger car, or Elmore 40. The latter is listed at \$2,500, while the three-cylinder car lists at \$1,750 in either type.

From the accompanying plan view of the Elmore chassis, which shows the Elmore 40 equipped with a four-cylinder, two-cycle motor, it will be quite apparent that the claims for simplicity and accessibility do not center entirely upon the power-plant, as the lines of the chassis of the car as a whole are quite in keeping with its motor on this score. There is a noticeable absence of complication or small parts, both the design and construction being distinguished by close adherence to the best standard practice, the chassis foundation consisting of the usual channel section pressed steel frame, the motor and change-speed gear being carried on a special sub-frame, while the propeller shaft is inclosed in a heavy steel tube which serves both as a protection and takes the place of the usual torsion rod. The use of the sub-frame for supporting the power-plant and drive permits of the latter being a close approach to a horizontal plane from the flywheel to the rear axle.

**MECHANICAL HORN AND PORTABLE RECTIFIER.**

Under the title of Klaxon, a new type of mechanical horn, which has much to recommend it on the score of simplicity and efficiency, has recently been produced by Miller Reese Hutchison, a New York engineer. The Klaxon horn consists of only two fundamental parts, a vanadium steel diaphragm and a hardened steel cam wheel. Attached to the center of the diaphragm is a hardened steel anvil, against which the cams on the periphery of the cam wheel strike, producing a violent

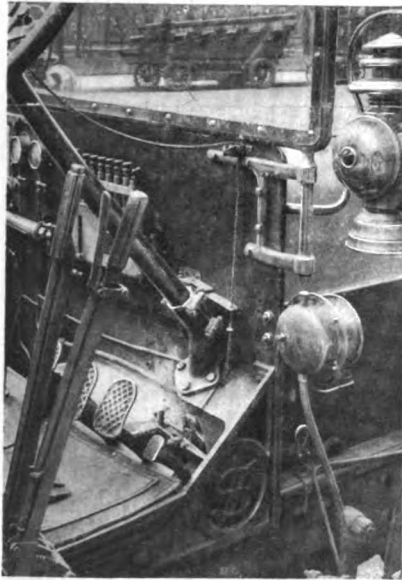

KLAXON HORN IN POSITION ON CAR.

inward and outward movement of the diaphragm, with astonishing results in sound propagation. The diaphragm and cam wheel are mounted in a special case, from which leads a flexible shaft that connects to a friction wheel engaging the periphery of the flywheel of the engine. This friction wheel has a grooved face, the tops of the grooves being sharp and hardened, so that should there be oil on the face of the flywheel, the sharp surfaces cut through

and engage the wheel without mechanical slip. A distinctive feature of the friction drive is the manner in which the wheel is pivoted to a bracket attached to the lower part of the dash and normally held by a spring against a braking surface. A chain passing over a suitable pulley on the dash and leading up to the steering wheel allows the horn to be put into operation instantly. On releasing hold of the chain the friction wheel is brought against the braking arm again with consequent instantaneous stopping of the sound. The cam wheel is so small and the power required by the Klaxon so slight that the sound reaches its maximum instantly and stops instantly without subjecting the flexible shaft to the starting and stopping torque.

For automobile use the horns are made in two styles, one being short for the dissemination of the sound through a large angle and intended for city and suburban use, while the other is 12 inches over all and intended for touring or use on motor boats. But the horn is designed to have a much wider use than on automobiles, and in view of its efficiency—for it is certainly one of the most powerful sound producers ever created—should be adopted on trains, fishing boats, or even, as is claimed, for use on battleships.

The device can be attached to cars in a few minutes. To make it adaptable to any position or any machine, both the driving shaft and the bracket supporting the pulley have been made reversible. Where not possible to operate the horn by friction, electricity can be employed by attaching a small electric motor. The apparatus can also be adapted for hand operation.

**Charging Storage Batteries with the Hutchison Rectifier.**

Automobilists who use storage batteries for their ignition system are frequently handicapped and delayed by inability to recharge when desired. The difficulty is particularly felt in rural districts, where, although there may be current, there are not the facilities necessary to make use of it for charging purposes. It is for this reason that a portable charging device, capable of being carried with facility on the

running board of the car, will be welcomed by those who travel by automobile. A device of this nature has been produced by Miller Reese Hutchison, forming, as will be seen from the illustration, a compact and easily portable apparatus. When not in use it is contained in a strong metal case and carried on the running board.

With an apparatus of this nature the automobilist is enabled to charge his battery from any existing electric light socket by merely removing the incandescent lamp from the socket and inserting the plug attached to the charging device. When the plug is inserted and the wires connected to the battery as designated by the tags, the charging device assumes two rôles: it enables the user, if the current is what is known as direct current, but which is seldom used in rural districts, to charge the battery so that the positive wire of the line is connected to the positive wire of the battery, as it should be. If it is alternating current the device rectifies it into direct current, and in such a way as to charge properly.

When connection is made to the electric light socket the lamps shown mounted on the board and used as resistance will light, showing that the battery is being charged properly and no further attention is needed. If they do not light, or burn with a very dull glow, it shows that the current is alternating and that the charging device is not properly connected. It is then necessary to pull apart the little plug screwed into the socket, then reinsert the bottom half of the plug, having turned it one-half revolution before inserting. This reverses the current through the device and through the battery, and the lamps will burn. A switch on the baseboard allows the battery to be disconnected from the charging circuit, and the small central lamp to be connected up. If the battery is fully charged this lamp will burn brilliantly. As the lamp uses considerable current, the temporary apparent charged condition of the battery is quickly run down if it is not fully charged, and although it may burn brightly at first, it will soon become dim. This test allows the state of the charge of the battery being determined without the use of delicate electrical instruments.

The elements of the rectifier consist of two large aluminum plates and one central composition plate, mounted on a support that has attached thereto a couple of lugs which engage the rods leading from the base on either side of the jar. Improper connection is prevented by these rods being of different sizes, with the holes in the connecting lugs each corresponding to the size of its rod. The jar is filled with an acid solution, the acids, which are cheaply renewable, being supplied with the apparatus, and is then ready for use. The contents of the jar being emptied out after charging, there is nothing to spill over and disfigure the box or apparatus.

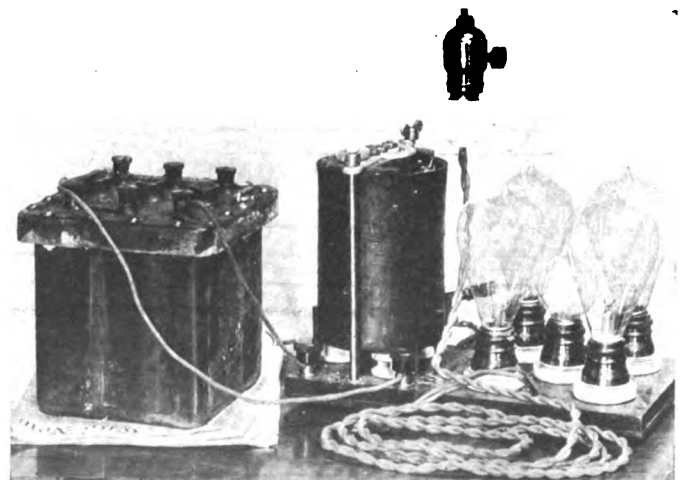

CHARGING A STORAGE BATTERY THROUGH HUTCHISON RECTIFIER

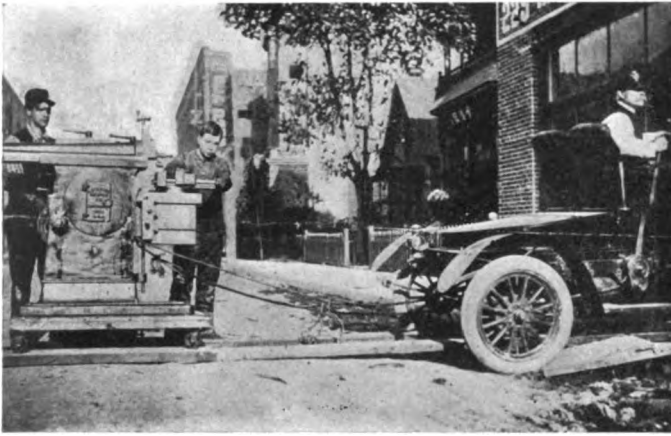

RAMBLER MOVING SHOP EQUIPMENT AT LOS ANGELES.

### ANOTHER USE FOR THE UTILITY AUTOMOBILE.

Moving machinery is the latest use to which an enthusiastic owner of a Rambler has put his car. He is D. C. Wilgus, a manufacturer of Los Angeles, Cal., and the manner in which some of the machines were moved from the old establishment to the new is made clear by the accompanying photograph. The feat which this Rambler Model 22 performed was actually the transfer of a complete machine shop from one point to another, the equipment including planers, lathes and general machine tools.

### STUDEBAKER TRUCKS FOR HANDLING METALS.

Two new electric trucks of 3 1-2 and 5 tons capacity that have recently been delivered to the Bourne-Fuller Company, of Cleveland, O., by the Studebaker Automobile Company, of South Bend, Ind., are of more than the usual interest in that they serve to show the adaptability of the electric vehicle to a wide variety of special uses. They are probably the first ever built with special reference to the convenient handling of steel and iron bars, sheets and strips, the driver's seat being located at the extreme left, thus making provision for the overhanging of extra long bars both front and rear. This construction permits of the easy handling of much longer pieces than could be carried on the average horse-drawn truck. Another interesting feature of these trucks is their tire equipment, which is of wood, thus materially reducing their cost as compared with the maintenance of rubber tires on such a vehicle. They are fitted with broad platforms, partly lined with steel to prevent wear. Both trucks are of exactly the same design, though of differing capacities and are mounted on the regular standard Studebaker electric chassis of the sizes and types in question.

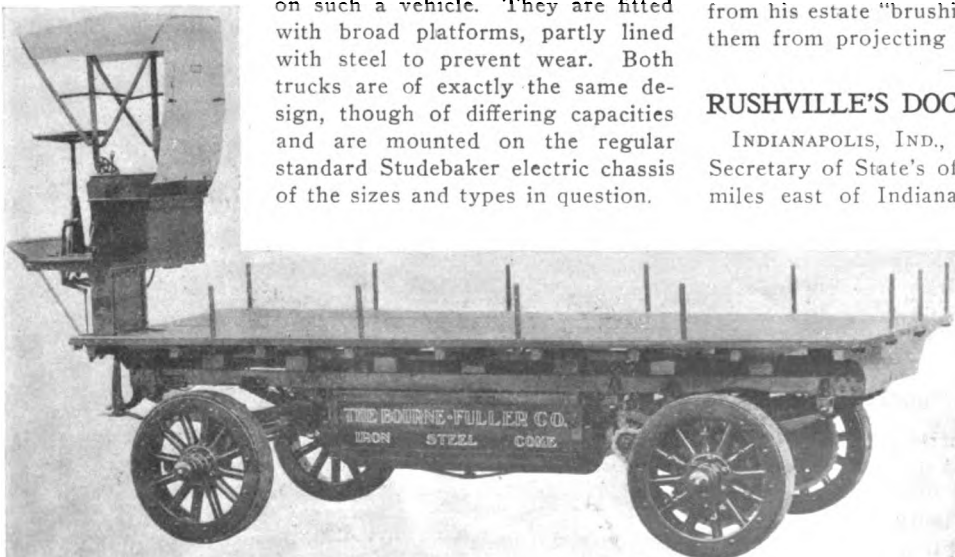

STUDEBAKER ELECTRIC TRUCK, MODEL 2126-C, 10,000 POUNDS CAPACITY.

### BRIDGING FLORIDA STREAMS FOR AUTO USE.

One of the greatest drawbacks in any country where the roads are not well settled and maintained is the lack of bridges to cross the more or less frequent streams and gullies. The route between St. Augustine and Ormond, Fla., is characterized by quite a number of such bad spots, or at least it was, until Thomas H. White, president of the White Sewing Machine Company, Cleveland, O., and of which the White Automobile Company is an offshoot, undertook to remedy this state of affairs. Mr. White has a winter country home at Daytona and frequently makes the trip from here to St. Augustine. It occurred to him that suitable bridges for automobiles could be made for the great number of small creeks without going to a great expense, and he accordingly went to work and devised what his neighbors have dubbed the "Incomparable White Motor Car Trestle," a sample of which is shown in service by the accompanying photograph.

It is practically two troughs supported by suitable stringers and tied an equal distance apart by cross pieces, this distance corresponding to the tread of a car. Since Mr. White has actively undertaken his work of bridge building, the trip between Ormond and Daytona has lost most of its terrors

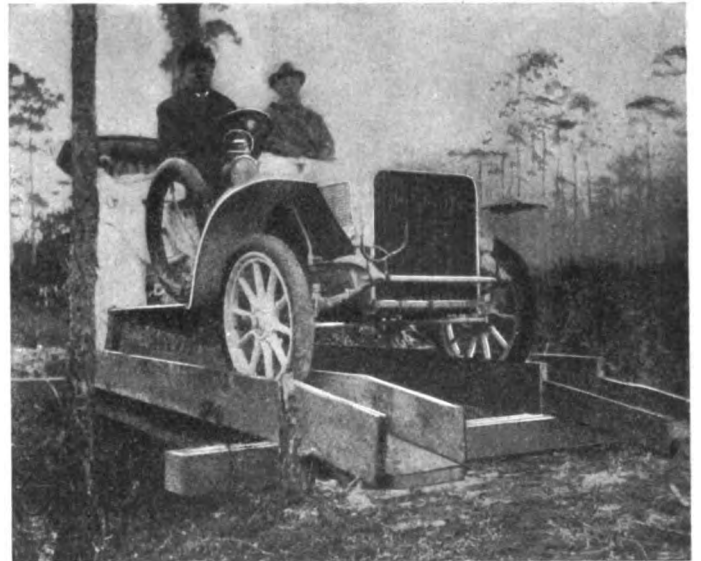

THOMAS H. WHITE IN WHITE STEAMER CROSSING TRESTLE.

and more tourists are making it than ever before. In addition to this work, Mr. White has also had the laborers from his estate "brushing" the roads—in other words, freeing them from projecting branches and brush.

### RUSHVILLE'S DOCTORS ALL USE AUTOMOBILES.

INDIANAPOLIS, IND., Feb. 3.—According to records in the Secretary of State's office, the city of Rushville, about forty miles east of Indianapolis, has more automobiles in proportion to its size than any other city in Indiana. Incidentally, Rushville is probably the only city in Indiana where 100 per cent. of the physicians use automobiles.

Rushville is the county seat of Rush County, which is said to have the finest farming land in the State. Physicians, business men and citizens use automobiles, and two garages have all the work they can do. There are fifty-five automobiles in the city and one motor cycle, three of the automobiles being electric.

## HORSE-DRAWN STATISTICS THAT INDICATE AUTO'S GROWTH

THE United States produced one million and a half horse-drawn vehicles, the majority of them being family and pleasure carriages, during the year 1905, the latest period for which returns are available. Tremendous as has been the growth of the automobile industry, it appears as yet to have had little influence on the growth of the carriage industry, according to complete figures compiled by *Commercial America*. In 1810 the aggregate value of the products of this industry for the whole country was \$1,421,000; by 1880 this had increased to \$65,000,000, and in the fifteen years that have elapsed since that time the value of the products of the carriage and wagon industry has grown until it amounts to \$125,000,000. How this last total has been modified by the automobile it is impossible to say with any degree of certainty, for, owing to the prosperous condition of the country, the two industries have grown concurrently, and have not yet been brought face to face in industrial conflict.

### 937,000 Carriages Made in 1905.

There were manufactured in 1905 no fewer than 937,000 family and pleasure carriages, most of which remained in the United States, export trade only being a minor feature. Naturally there will always remain a limited number of users who, by preference or supposed economy, will remain true to the horse and buggy, but the total given, which represents a value of \$55,000,000, shows that there is still a tremendous field which the automobile builder may invade and reasonably hope to capture by quicker, cheaper and more economical methods of mechanical transportation.

The most popular of all types of horse-drawn carriage is the buggy, used as much for business as for pleasure purposes. Its use as a pleasure vehicle is probably larger than is generally supposed, as is shown by the fact that when the farmer has had a profitable season the farmers' boys are large purchasers of these vehicles for other than business uses. With road conditions as they stand at present, it is in this field that the automobile builder has the widest possibilities for immediate expansion, with a mechanical vehicle reduced to its simplest forms.

### Scope for Auto Conquest in Commercial Field.

There is equal scope for conquest in the commercial field—though the change there is not likely to be effected with the same facility—in the 643,000 wagons for business and farm use turned out in 1905 at a value of \$37,000,000. In addition, 127,000 sleighs and sleds, valued at over \$2,500,000, were produced during the same period. There were also 8,676 carriage bodies, 8,855 wagon bodies, and 389,266 wheels made in the carriage factory. Deducting \$28,000,000, the value of all other products, from the gross value, leaves \$97,000,000

to represent the value of the finished vehicles of all classes. One of the distinctive features of the carriage and wagon industry has been its specialization; whereas in the early days the entire work of manufacturing was done in one establishment, now separate factories make a specialty of the different parts, very few, if any, manufacturers making a complete vehicle.

### Establishments Decreased, Capital Increased.

Though the number of establishments has decreased from 6,204 in 1900 to 4,956 in 1905, the amount of capital invested has shown a decided growth and now reaches \$126,320,604. The total cost of material used is estimated at \$61,215,228. In this amount rubber tires figure for \$2,626,889. The following table will give a comparative summary of the statistics of the carriage and wagon industry for the years 1880, 1900 and 1905:

	1905.	1900.	1880.
Number of establishments....	4,956	6,204	3,941
Capital .....	\$126,320,604	\$109,876,885	\$37,978,493
Salaried officials, clerks, etc....	5,058	4,008	
Salaries .....	\$5,239,043	\$3,576,915	
Wage-earners, average number	60,722	58,425	45,394
Total wages .....	\$30,878,229	\$27,578,046	\$18,988,615
Men 16 years and over.....	59,411	57,209	43,680
Wages .....	\$30,525,515	\$27,264,021	
Women 16 years and over...	870	840	278
Wages .....	\$266,674	\$248,071	
Children under 16 years....	441	376	1,491
Wages .....	\$86,040	\$65,954	
Miscellaneous expenses .....	\$10,182,614	\$5,800,687	
Cost of materials used.....	\$61,215,976	\$53,723,311	\$30,597,086
Value of products, including amount received for repair work .....	\$125,332,976	\$113,234,950	\$64,951,617

Of the total number of establishments reported in the United States in 1905, 38 per cent. were located in cities having a population of at least 20,000 and the value of their output was \$70,000,000, or 56 per cent. of the total for the United States. In the States, Ohio leads with the greatest value of carriage and wagons for 1905, followed in order by Indiana, New York, Michigan, Illinois and Pennsylvania.

### America's Only Foreign Market Competitor.

Exports of carriages, wagons and parts only amounted to \$4,270,000 in 1906, the countries supplied being Argentina, Canada, Mexico, Great Britain, Australia, South Africa and Cuba. America's only competitor in foreign markets is Great Britain, which exported to the value of \$1,540,000 in 1906, or about 70 per cent. of the amount handled by the United States. French exports consist mainly of very fine and expensive carriages, this being the only class of goods in which it competes with the United States.

## FIGURES THAT IMPRESS ALL WHO STUDY THEM.

"That automobile popularity is far from waning, as many pessimists have endeavored to make us believe, is strongly contradicted by the registrations with the Secretary of State at Albany during 1907," says S. H. Mora, maker of the Mora car and a member of the American Motor Car Manufacturers' Association. "During 1907 there were 13,980 owners registered and 9,386 registrations for chauffeurs, against 11,649 owners, and 7,335 chauffeurs in 1906. To me these figures are impressive, as they must be to anyone who will study them. It means that the American manufacturer is offering the public the very best car possible to build for the money; or else, the sales of American cars would not have had such an increase during the past year."

## 7,000 PENNSYLVANIA LICENSES SINCE DEC. 15.

PITTSBURG, Jan. 27.—More than 7,000 automobile licenses have been issued by the automobile division of the State Highway Department of Pennsylvania since December 15. This is a big increase over the corresponding period of 1907.

Automobilists of Western Pennsylvania are agitating a system of uniform signals to be adopted throughout the State. The signals suggested are as follows: One blast: "I am going straight ahead"; two blasts: "I am turning to the right"; three blasts: "I am turning to the left"; four blasts to mean: "Your lamp is out"; five blasts to mean: "Do you require help?"; two and one to mean: "Yes"; two and two to mean: "No." Such a system of signaling would doubtless be of value if automobilists can be induced to adopt it unanimously.





Vol. XVIII

Thursday, February 6, 1908

No. 6

THE CLASS JOURNAL COMPANY

Flatiron Building, Madison Square  
New York City

H. M. SWETLAND, President

EDITORIAL DEPARTMENT

A. G. BATCHELDER, Managing Editor  
R. F. KELSEY, Associate Editor C. B. HAYWARD, Engineering Editor  
W. F. BRADLEY

BUSINESS DEPARTMENT

A. B. SWETLAND, Business Manager  
LOUIS R. SMITH FRANK B. BARNETT  
W. I. RALPH, 1035 Old South Building, Boston, Mass.  
C. H. GURNETT, H. E. WESTERDALE, 836 Monadnock Block, Chicago, Ill.

Cable Address - - - - - Autoland, New York  
Long Distance Telephone - - - - - 300 Gramercy, New York

SUBSCRIPTION RATES:

United States and Mexico - - - - - One Year, \$3.00  
Other Countries in Postal Union, including Canada, - - - - - One Year, 5.00  
To Subscribers—Do not send money by ordinary mail. Remit by Draft,  
Post-Office or Express Money Order, or Register your letter.

FOREIGN SUBSCRIPTION AGENTS:

ENGLAND:—Hilffe & Sons, Limited, 29 Tudor Street, London, E. C.  
FRANCE:—Boyveau & Chevillet, 22 Rue de la Banque, Paris.  
GERMANY:—A. Seydel Mohrenstrasse 9, Berlin.

Copyright, 1907, by The Class Journal Company.  
Entered at New York, N. Y., as second-class matter.

The Automobile is a consolidation of The Automobile (monthly) and the Motor Review (weekly), May, 1902, Dealer and Repairman (monthly), October, 1903, and the Automobile Magazine (monthly), July, 1907.

Copies printed in 1905	- - - - -	730,000
“ “ in 1906	- - - - -	791,000
“ “ in 1907	- - - - -	888,000

**Hailing the Small Run.** So much success attended the privately organized races for small runabouts last year that the Automobile Club of France has decided to precede its annual race for the Grand Prix by a speed contest limited to this class of diminutive automobile. Apparently the movement will not stop here, for there is already a distinct demand in English automobile circles for a race of a similar nature.

The class of machine which it is sought to popularize and develop is a little two-seater with an engine not exceeding 3.9 inches bore for a single cylinder, or, roughly, fifteen horsepower. As America has already proved in two or three notable instances, there is an almost unlimited demand for a popular machine of this nature, selling from five hundred to one thousand dollars; the demand, too, will be confined not to one or two countries, but to every land where roads exist. It is surprising, therefore, that greater official attention has not been paid to such an important section of the automobile industry. In France it was necessary that there should be serious indications of the limit of expansibility in the large car trade before whole-hearted attention was paid to the popular runabout. Once realized, however, there has been no delay in entering into what promises to be a field of activity that will equal the trade in automobiles de luxe.

It would be interesting to see the one American constructor who has resolutely invaded Europe with a four-cylinder runabout lined up against the products of the old world. Despatches received from across the Atlantic ap-

pear to indicate that the representative of the firm in question will not race because the limited bore makes it impossible to put in the stock American car. It is for the manufacturer alone to say whether it is worth while to construct special baby racers; it is certain, however, that the American industry would gain more at home and abroad by participation in races of this nature, or organizing contests on similar lines, than in running in expensive high speed tests.



**Expanding the Market for American Automobiles.** In beginning this with the title given, there is no intention of further dwelling upon that subject, which is being so constantly brought up—the benefit to be derived from seeking export outlets—but rather to call attention to one phase of the influence of the comparatively new buggyabout that appears to have been generally overlooked. Cars of this type have been on the market for several years, but it is only within the past two or three that they have assumed any great importance. It is evident that the car selling for a few hundred dollars cannot be marketed profitably by the same selling methods that characterize the disposal of \$5,000 cars. To give proportionate returns, the sales must be large, so that the average dealer accustomed to handling larger cars is naturally not over-enthusiastic about the buggy type.

Here is the carriage dealer's opportunity, and there appears to be little doubt that this trade as a class recognizes the value of the opening and will take advantage of it, particularly as the far-sighted ones in this business have long been feeling the influence of the automobile and have wished to get in line with the advanced movement rather than array themselves against what they knew was inevitable. In this manner the number of automobile agencies in the country will be increased by thousands of new dealers in a short space of time, nor is it to be anticipated that with a little experience such dealers will confine themselves to the smallest cars, so that in the course of a year or two the sales of American cars at home should expand greatly by reason of the number of people selling them, even if no other cause were present. It marks a long step forward in the education of the public to the automobile.



**New York-Paris Run Will Be a Good Educator.** In ten days the world will have an opportunity of making a comparative inspection of the machines intended for the longest and most exacting automobile tour ever conceived by an imaginative Gallic mind. The six foreigners being already in mid-Atlantic may be considered certain starters, and four of them at least appear to have been constructed and fitted out with a determination to go through to the end. Though so near at hand, practically nothing is known of the four American cars, still announced as being ready to line up in Times Square on February 15. A sufficient explanation for the smallness of the home contingent is to be found in the briefness of the period between the announcement of the event and its practical execution. But inspiration cannot be forced, and it would be unreasonable to demand an exception of the *Matin* publicist.

When everything has been said on the uselessness, the foolhardiness, the absurdity of the New York-Paris automobile tour—and enough could be said to fill the ample columns of both journals interested in its execution—the fact remains that it will have a general educative value unequalled by any other demonstration. Automobile construction is not likely to profit one iota, but the automobile industry throughout the world will benefit by an immense publicity which could not have been obtained in any other manner. For three months the eyes of the entire world will be focused on the small group of cars, and the world cannot but be impressed by what the automobile is capable of doing.

## TWO-CYCLE VS. FOUR-CYCLE IN GRAND PRIX RACE

PARIS, Jan. 27.—The voiturette race to precede the French Grand Prix will probably see the inauguration of the two-cycle motor as a racer. The club having decided to allow two-cycle motors to compete in both events under the same conditions as those of the four-cycle type, four firms at least have made the announcement that they will enter the small car race with single-cylinder two-cycle motors of 3.9 inches bore. Instead of 15-horsepower, which is about the maximum from a 3.9-inch four-cycle engine, it is calculated that 18 or 20 horsepower will be obtainable from the two-cycle competitors. The event will be watched with considerable interest, for should a two-cycle win, or even make a good showing, the popularity of this type of engine will be enormously advanced. Isotta-Fraschini, the first official entrants in the Voiturette Grand Prix, announce that their cars will have four-cylinder four-cycle engines of 2.4-inch bore.

Ford participation in the small Grand Prix race is under consideration, but has not yet been definitely decided upon. Henri Dépasse, who recently undertook the exclusive agency in France for the popular four-cylinder American runabout, declares that he would be glad to take part in the race if the rules allowed his 3.7 bore engine to compete. It is not likely that there will be any change in the rules of this or any of the succeeding voiturette races which would allow the Ford to compete, and the only possibility of making a demonstration against European cars would be by constructing special racers. One hundred millimeters bore for a single cylinder—equivalent to 3.9 inches—is considered the limit for a small runabout in France, and although nobody denies that the little Ford is a runabout, it is not allowed to line up with its smaller European rivals under present rules.

Victor Breyer, who last year so ably managed the French Grand Prix that the Racing Board found itself with a large balance in hand at the end of the race, has been succeeded by Georges Desson, the organizer of the Gordon Bennett race

of 1905 and other sporting events of lesser importance. The change of management is not due to any dissatisfaction with the work of the previous délégué général, but has been prompted by a desire to give other favorites a share in the work. Under the new régime, which aims at making a financial success of the Grand Prix, the general manager will have a more difficult task on the popular circuit likely to be adopted than in distant and wild Auvergne.

Dieppe offers \$10,000 and a remade set of roads to have the race in its district. The amount is only half that of last year, but the Dieppe authorities refuse to hand out another cent. Probably the Racing Board would accept their offer if the land adjoining the course had not gone up enormously in value. It would have been cheaper for the club to have bought it outright a year ago than to pay the price that is now being asked for three or four days' rent. Owing to this, other districts are being examined.

Maurice Farman, brother of Henry Farman, of aeronautical fame, has been selected to drive one of the Panhard racers in the Grand Prix. His companions will be George Heath and Cissac, the well-known motorcyclist.

Discussion has been aroused by S. F. Edge's attack on the Grand Prix rule forbidding the changing of wheels. England's greatest publicity expert declares that though he has three six-cylinder cars ready for the Grand Prix he will not enter them as long as the rule against changing of wheels remains in force. Dismountable rims are allowed under the racing rules, but dismountable wheels are forbidden. As it is this latter type that Edge has always employed on his racers at Brooklands track, he sees in the rules of the French club an attack on the British industry, and strikes back with all the vigor of his vigorous pen. Refusing to enter the road race without his own type of dismountable wire wheel, he challenges René de Knyff, of the Panhard firm, to a special track race, and has deposited \$1,250 stakes with the Brooklands club for such an event.

### RHODE ISLAND LAW HAS MANY FEATURES.

PROVIDENCE, Feb. 3.—The new automobile law about to be presented to the General Assembly is unique in that it has the practically unanimous support of the people of the entire State. It is the work of the special legal committee of the Rhode Island Automobile Club, consisting of Dr. Julian A. Chase, Col. Frank W. Tillinghast and J. Jerome Hahn, and contains a number of new features.

The penalties have been made severe, ranging from a fine of \$10 to \$500, or imprisonment from 10 days to one year, or both, for the violation of any of the provisions of the bill. It is also made an offence for the driver of a car to leave the scene of an accident in which he was concerned without giving his name and address to some person connected with the person or property injured or damaged. When left standing all cars must be so locked as not to be operated by any unauthorized person. All money received from fees is to go to the support or improvement of the roads, the charge being \$2 for registration and the same amount for drivers' licenses.

Section 10 of the new bill is a reciprocal provision aimed at those States which do not permit the driving of a car on their roads by a non-resident without taking out a license, and provides that only non-residents of States that recognize Rhode Island licenses shall be immune from the operation of the new law for a period corresponding to that allowed to outsiders by their home States.

### BAY STATE AUTOISTS OFFER REWARDS.

BOSTON, Feb. 3.—Never have local automobilists been aroused over the wrongdoing of one of their own fraternity as they are at present on account of the action of a driver in running away after striking a little girl in the town of Milton, one of the suburbs of Boston. According to witnesses the accident was unavoidable, but the driver, after carrying her to the door of her home, drove away without revealing his identity. As soon as the circumstances became known the Bay State Automobile Association offered a reward of \$50 for the conviction of the party responsible. The Automobile Owners' Association has added \$100 more and Frank J. Tyler of the Maxwell-Briscoe Boston company offered an additional \$50. Then Charles S. Henshaw of the Haynes company offered \$25 and the Safe Roads Automobile Association announced that its standing reward in such cases is \$50. Thus the aggregate reward now amounts to \$275. This case will undoubtedly do much to aid in the passage of a bill now before the Legislature designed to cover just such accidents. At present even if the responsible autoist or autoists are caught, it is doubtful if they could be successfully prosecuted, and there is no penalty for running away, except possible revocation of the license. The bill referred to makes running away after an accident punishable the same as reckless driving or operating while under the influence of intoxicating liquor, the punishment for which is a fine not exceeding \$100 or imprisonment for not more than six months.

## AUTOING THROUGH THE ISLAND OF SUGAR.

(Continued from page 170.)

of way goes up and down over clay banks and is thickly covered with rank grass concealing all kinds of stones, bumps and hollows. Then imagine a motor trip over it and you will have a fair idea of the best road we struck for many a toilsome league. A league, by the way, is the universal standard of measure in Cuba, and it means nothing in the mind of the man who tries to tell you how far it is to somewhere. The average country Cuban has never been further than a few miles from his own home.

We managed to get away off the route, and miss the towns we expected and find others we did not want. Toward the close of the afternoon we learned that we were cutting across fields and over unused trails and along forgotten highways to Esperanza, so we knew that we would then be on the way to Santa Clara. The rivers were close together. We forded nine that day, including some where the climbs up the far bank were so steep that if named in grade per cent. would not be believed.

### We Slip Into a Bog.

Nightfall caught us in the one-too-many bog—a wide one into which we had slipped off the edge of a ridge. The car sank to its axles. Luckily we were in a region of stone fences. Jacking up one wheel at a time with stone fulcrums and saplings for levers, we built a rock foundation under each. Some Cuban farmers came along and helped us. Under the leadership of a lean, wiry individual they hustled with amazing energy. Through the night rang the quick: "Espere un poco!" and the commanding "A un tiempo!" directing the movements of the men on the ends of the levers. When the car had a foothold, the motor was started, and, with a great upheaval of rock and mud, jumped to the hard ground, the interested natives let out a loud yell of approval and the wiry one shouted:

"El Toro! El Toro!" Thus the car got its nick-name.

Some more smaller mud holes, then a hill hewn roughly out of the native rock, and climbed slowly to the dark, and we drove into Santa Clara, proudly directed to the hotel by one of the Cubans who had come along as guide. He was soon the center of an eager crowd and probably told fearful and wonderful tales of this automobile in which he, among all Cubans of the province, had been the one to ride.

### Rest of Tour in the Rain.

The rest of the tour was in the rain. Roads which had been fairly good when dry turned to slippery rinks of red mud. Ruts which could be ridden on the ridges during dry weather could be taken only by the most careful driving and arduous road picking. Ravines were so slippery that it seemed worse than foolhardy to try to either ascend or descend. Rivers rose. Bogs and swamps were turned into streams of soft mud. At each one we had to stop to find out if the bottom were hard or soft. We had profited by experience. A hard bottom one we took by "shooting it," a process which explains itself. The deep, wide, treacherous swamps we bridged with rough corduroy roads of palm trunks and underbrush. It was hard work. We forded three mountain rivers, for now we were in the Santa Fé mountains and were glad when, at the top of the struggling ascent up the rain-washed pass, we found a shelter and something to eat in a little grocery annex to the home of a farmer. Waldon bunked on a bench, with the seat cushions for mattress and fleas for company. The rest were on cots or in hammocks. The night was cold. We were stiff in the morning when we looked out on another day of rain and a perspective of mountain ridges, gullies, rivers and lowland sloughs. Until noon we worked getting over the three miles to Camajuani. This meant two rivers, hills and innumerable swamps. The engineering department, armed with axe, shovel and mattock, worked ahead and every inch of the way we repeated the

cablegram we had received at Santa Clara from the general manager: "Have a good time."

The rest of the day was a continuance of the same thing and we made one less mile than the day before—thirteen instead of fourteen. At night we were still "shooting," dodging or fighting through mud holes and quit the day's work at a sugar plantation. We had supper in the laborers' eating house and slept on the same table. We dried our clothes over the kitchen fire, and laughed at each other and recited our experiences of the day.

We hit Placetas early the next morning, and found that we had made a needless trip through the Santa Fé mountains. We should have cut straight across from Santa Clara and left Camajuani and Camajuani river peacefully unaware of our existence. So we promptly left Placetas by the wrong road and at noon discovered we had made a goodly number of hard-earned, rain-soaked miles back towards Santa Clara. Twenty-seven miles altogether brought us to a tobacco plantation, and we were taken in.

That was a wonderful supper—the best we had had. Potage of beans, other vegetables and meat; fish, guinea, rice, fried potatoes—we were hungry and we ate voraciously under the eyes of *senor*, *senora*, *senorita*, and the children who were under the clothes age limit. Then we discussed ourselves and marveled at the racking we had given "El Toro," marveled at the way the tire casings had stood the abuse on the rocks, marveled at the feats of rough and ready road engineering and motor car driving which had been performed. Meanwhile *senora* slung hammocks for us, and when we went to them, lo, they were in a thatch-roofed pig pen! So we counted the eight pigs in the glare of a side lamp and chanted the glad refrain of that cablegram:

"Have a good time!"

### Country Soaked to the Marrow.

The last day—if we could make the 28 miles to Sancti Spiritus in one stretch of daylight. Ahead we could always see the mighty Tuerto, flanked by Cabellete de Casa and La Gloria. The whole country was soaked to the marrow. The farmers told us that this rain was a delayed wet season. It seemed to us to be the real article. With the tonneau a mud-soaked mess of road tools, canned food, grips and blankets; with all but the driver on the running boards when we were not all out in the road shoveling, carrying stones or prospecting, we worked by right road and wrong road toward the town Guayos, where we debated whether we should stay for the night or take a chance of finishing it up rain or shine, muddy or dry, hills and rivers be d—d. A Cuban rural guard said that just over the next hill started a good road stretching to Sancti Spiritus. That next hill was like tomorrow, which never comes. Up one steep ascent of yellow clay, running with water, and so slippery that even the few sure-footed Cuban ponies which we met slid, sprawled and fell; down again and up, always looking for that promised road "over the next hill." We found it just outside of Sancti Spiritus, and the whole population of that city is still telling of how they flocked into the narrow streets to see the arrival of the automobile.

There is more to tell—the little things which were big at the time; the funny things and the hardships; the people, their homes, their country and their ways; the experiences in the towns and the disappointments in the country. There was so much to tell that each new hour's experience drove almost from mind that of the previous hour. One thing we had always in mind. We had done what we had been told could not be done; we had traveled where no other four-wheeled vehicle had ever traveled; we had conquered in our Packard "Thirty" the alleged impassable obstructions of the wild interior of Cuba—we had made good and did not care a rap that we had no clean clothes in which to appear before the elite of Sancti Spiritus.

E. R. S.

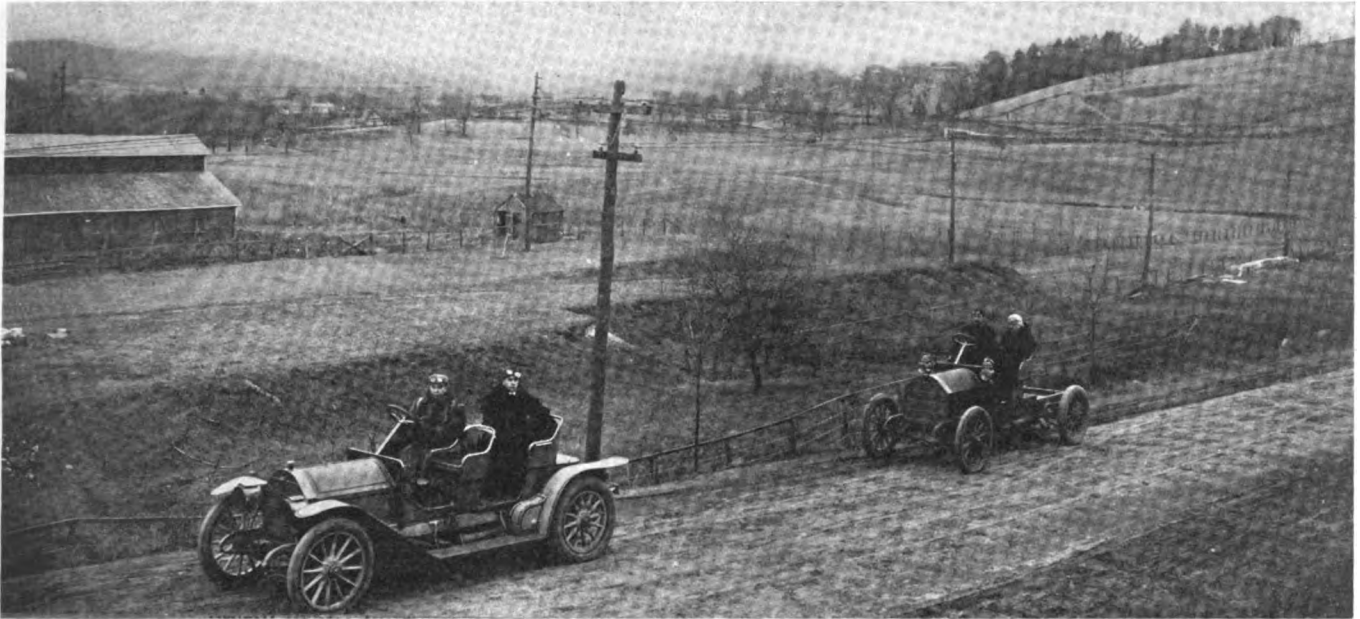

JOE TRACY, WITH A SIMPLEX, INVESTIGATING THE BRIARCLIFF COURSE, WHICH HE SAYS WILL TEST A CAR'S DURABILITY.

**BRIARCLIFF ENTRIES NOW NUMBER NINETEEN.**

Entries for the Briarcliff Trophy race are closed—officially at any rate. Whether others will be allowed to come in after the door has been reluctantly locked and barred is difficult to determine. "We have \$9,500 in the bank," declared Thomas Francis Moore, secretary of the race. As each car must pay \$500 entrance fee on account, a little mental arithmetic brings the number of engagements to 19. To assure success and safety it had been determined to limit the entries to 30, but in view of the shortage a different problem presents itself. Says Manager Moore: "The Manufacturers' Association has decided to accept additional entries at an increasing fee each week until the total is made up. They also gave Robert Lee Morrell power to act as he thought best, and his opinion is that no more entries should be received, in justice to those already engaged."

Chairman Robert Lee Morrell, interviewed on the situation, said: "The entry lists are closed; but if anybody else wants to come in, let him send his application along and it will be considered by the present contestants."

The list of entries as given out is as follows:

H.P.	Car.	Owner.	Driver.
30.	Hol-Tan	C. H. Tangeman	Basle
30.	Stearns	H. W. Whipple	Oldfield
30.	Stearns	F. B. Stearns	Leland
30.	Stearns	Wyckoff, Church & Partridge	Vaughan
50.	Simplex	Palmer & Singer	Tracy
35.	Allen-Kingston	A. Hammerstein	Campbell
50.	Lozler	H. A. Lozler	Michener
50.	Lozler	H. A. Lozler	Mulford
50.	Thomas Flyer	S. A. Houpt	Roberts
50.	Apperson	S. B. Bowman	
50.	Isotta-Fraschini	C. Hamilton	Poole
50.	Isotta-Fraschini	C. Hamilton	Harding
50.	Isotta-Fraschini	J. H. Tyson	Strang
30.	Flat	E. R. Hollander	Cedrino
30.	Flat	E. R. Hollander	Ryall
30.	Renault	Paul Lacroix	Bernin
50.	Panhard	A. Massenat	Robertson
50.	Panhard	A. Massenat	
35.	Maja	J. J. Brown	Murphy

**No Locomobile in Briarcliff Event.**

BRIDGEPORT, CONN., Feb. 3.—In spite of current reports to the contrary, the Locomobile Company announces that it has not planned to enter a car in the Briarcliff trophy race to be held in Westchester in April next. This decision is not based on any unfavorable attitude toward the event, but coming as it does when the entire factory force is engaged in turning out cars, the makers do not wish to have the daily routine of their operations seriously disturbed at such a critical season.

**SAVANNAH MEET PROMISES GREAT SUCCESS.**

Three Appersons, one Premier, and two Isotta-Fraschini cars are now entered for the road races to be held on the Savannah course, March 18 and 19, under the auspices of the Savannah Automobile Club and the A. A. A. Harding and Poole will probably handle the Isotta cars, and George Robertson and H. H. Van Tine will be given charge of the two Apperson "Jackrabbits." From inquiries made regarding the race, entries are likely to be large, and the enthusiastic co-operation of the district is already assured. Among those who have recently visited the course are representatives from Dragon, Stearns, and Mitchell, and Continental and Michelin tire factories.

According to reports from the Savannah Automobile Club, several hundred convicts, who are the roadmakers of the South, have been put to work on the course.

The Savannah Challenge Trophy, to be presented to the winner of the 360 miles stock chassis race, will be a life-sized bust of Tomachichi, chief of the Yumacrew tribe of Indians, and a personal friend of General Oglethorpe, founder of the city of Savannah. A roughly carved granite monument to Chief Tomachichi occupies a position in one of the public squares of Savannah, and it is a reproduction of this in silver which is intended. The war bonnet, which is a string of feathers, is so arranged that extra feathers can be inserted in it. As the trophy must be won three times before becoming the property of any manufacturer, each winner will receive a silver feather with particulars of the victory engraved upon it, and a duplicate feather will be put in the head gear of the chief. The Southern Runabout Cup and the Southern Six-cylinder Cup will become the property of the winners.

**NINE MORE DAYS FOR ORMOND ENTRIES.**

Nine days remain in which entries for the Ormond-Daytona beach races may be made to the Automobile Club of America. W. Gould Brokaw has put in the Christie front-drive racer; the Fiat Cyclone, a recent arrival from the Italian factory, has been entered, and Haynes and Renault have each engaged a racer, the French car to be handled by Bernin. The Maxwell twelve-cylinder racer is considered a possible starter. The race for the Dewar Trophy has been removed, and a one-mile straightaway substituted, the qualifying long-distance clause being retained. David Bruce Brown has entered in the amateur event.



## RHODE ISLAND HAS A FINE SHOW.

PROVIDENCE, R. I., Feb. 3.—Over a hundred automobiles with their highly polished metal trimmings and many colored enameled bodies reflected the rays of a thousand lights in the new State Armory when the first Providence show was thrown open to the public last Saturday night. The weather conditions on the opening night were wretched, but in spite of the elements several thousand persons filled every aisle and thronged through the spaces reserved for the exhibitors, admiring the rich displays and tasteful decoration scheme which gave them a perfect setting.

The mammoth auditorium, or drill hall, of the armory, large enough to provide room for an entire regiment to be drawn up in order, is divided into three main aisles running the length of the hall, while other broad avenues cross the exhibition room at each end. All of the floor, excepting that portion taken up by the aisles, has been covered with green carpet bordered with dark red, while the exhibition spaces are defined by strips of dark red, which adds a touch of color to the floor decorative scheme. Tall slender palms mark the corners of the several spaces, while overhead are hangings of green and red burlap, forming a frame to mark the boundaries of the stalls. Huge American flags are suspended from the lofty girders, while flags of all nations are tastefully draped beneath. Both balconies have buff and blue striped bunting hung from the railing, while in the background are huge paintings and the national colors.

The automobile show affords the people of Rhode Island the first opportunity to view the interior of the State's newest public building, and the great auditorium, 270 feet long and 170 feet wide, has been transformed into a fairyland such as has never before been seen in the State.

Models of the foremost makes of automobiles are on exhibition, the total number being 120 separate cars, with over 40 concerns represented. Herewith is the car list:

American Locomotive Car (Berliet): American Locomotive Automobile Company  
 American: W. A. Fredericks Company  
 Atlas: Crane Automobile & Garage Company  
 Buick: Davis Automobile Company  
 Cadillac: Davis Automobile Company  
 Corbin: Arthur S. Lee  
 Elmore: Pugh Bros.  
 Ford: Providence Motor Car Company  
 Franklin: Dauer Automobile Company  
 Glide: Crown Motor Car Company, Boston  
 Grout: Aetna Bottle & Stopper Company  
 Jackson: C. M. Linton  
 Kiblinger: Crown Motor Car Company, Boston  
 Knox: Foss-Hughes Motor Car Company  
 Locomobile: Davis Automobile Company  
 Marion: W. A. Fredericks Company  
 Marmon: Frank E. Wing, Boston, Mass.  
 Maxwell: Aetna Bottle & Stopper Company  
 Mitchell: William A. Harris Steam Engine Company  
 Northern: Edgewood Automobile Company  
 Oldsmobile: Davis Automobile Company  
 Overland: W. A. Fredericks Company  
 Packard: Flint Motor Car Company  
 Peerless: Davis Automobile Company  
 Pierce-Arrow: Foss-Hughes Motor Car Company  
 Premier: J. O'Donnell  
 Rambler: Whitten Motor Vehicle Company  
 Reo: William Hughes Company  
 Royal-Tourist: Arthur S. Lee  
 Stanley: Central Automobile Exchange  
 Stevens-Duryea: Snow Automobile Company  
 Stoddard-Dayton: Nock Automobile Company  
 Studebaker: Pawtucket Automobile Company  
 Thomas: Davis Automobile Company  
 Welch: C. M. Linton  
 White: Central Automobile Exchange  
 Winton: Davis Automobile Company

### COMMERCIAL TRUCKS.

American Locomotive Automobile Company  
 Foss-Hughes Company

The accessory list is lengthy and as follows:

The Villers Company.....Optical supplies  
 Thompson Art Company, Portland, Me.....  
 Belcher & Loomis Hardware Company.....Marine supplies  
 The Angler Company.....Accessories  
 Aspinwall Hardware Company.....Marine supplies  
 William A. Harris Steam Engine Company.....Engines  
 Waite Auto Supply Company.....Accessories  
 A. W. Harris Oil Company.....Oils  
 Blanding & Blanding.....Cigars  
 John A. Gammons.....Automobile insurance  
 Nonparell Brass Company.....Accessories  
 Visor Knitting Company, Niagara Falls, N. Y. Caps

Combination Ladder Company.....Chemical engines and accessories  
 J. B. Draper Company, Brunswick, Me.....Robes  
 Vacuum Oil Company.....Mobliolls  
 Eutaw Supply Company, Boston, Mass.....Accessories  
 W. R. Harris.....Marine engines  
 Century Optical Company, New York.....Optical supplies  
 B. A. Swenson.....Motorcycles  
 L. F. Pease Company.....Tents  
 Ira N. Peck.....Ball bearing tires  
 Providence Telephone Company.....W. R. Richards  
 Welch Grape Juice Company.....Motor Car Specialty  
 Spare Wheel Company, Ltd. Atlantic Boat Company  
 Mianus Motor Works New England Automobile Journ.  
 Modox Company Providence Tribune

## CENTRIFUGAL PRINCIPLE OF THE VEEDER.

Editor THE AUTOMOBILE:

In your issue of January 30 we notice that you have given publicity to an article concerning speed indicators of centrifugal types.

The Veeder Manufacturing Company manufactures a speed indicator called the Veeder Tachodometer, which depends on the centrifugal principle, but not on the position of a revolving weight. It is well known to anyone who has investigated the matter, that a speed indicator built by having for the moving force weights which take different positions according to the centrifugal force developed by the speed of the instrument, will, by the nature of the instrument itself, give more movement for a low speed than for a high speed. This is corrected in almost all these instruments by a cam.

The Veeder Tachodometer does not use any cam to adjust the graduations on the scale so as to make them even. On the contrary, the graduations are closer at the low speeds than at the high speed. This is a very desirable item, as it renders the instrument much more easy to read at a high speed than at a low speed, and it is when running at a high speed that one needs to read the instrument at a glance. If the graduations are all even, they are no more easily read when one is going 60 miles an hour than when one is going 10 miles an hour. A car running at 60 miles an hour, however, requires nearly all of the attention of the driver, and he should not be compelled to spend much time to determine his exact speed. For this reason the Veeder Tachodometer is very much more desirable as a speed indicator than any instrument having an evenly graduated scale, and exceedingly more desirable than an instrument which has closer graduations for the high speeds.

It is not claimed that the Veeder Tachodometer is absolutely accurate. Such a claim is on the face of it absurd. It is claimed, however, that this instrument is accurate within an error of one per cent. There are no parts of the instrument subject to wear, which would tend to make it inaccurate after a period of use. It has ball bearings throughout, and the only part which moves is the paddle which imparts motion to the liquid in the instrument. For this reason the instrument might be used for ten years and at the end of that time show no greater inaccuracy than when it was first made. This could not be true of any purely mechanical instrument, because the wear on such an instrument does cause an appreciable increase in the error.

Any instrument in which a cam is used wears out of accuracy more rapidly than if the wear were simply on the bearings. A cam will always wear in spots, either because of inequalities of the structure of the material of which it is made, or because of inequalities in the forces which act upon it at different times. These objections have been overcome in the Veeder instrument, and for this reason it is by all odds the most accurate and reliable instrument for speed indicating now on the market.

THE VEEDER MANUFACTURING COMPANY,

Hartford, Conn.

A. Trowbridge.

## PLACE TO CARRY LIGHTS; HOW TO TRUE THEM.

Editor THE AUTOMOBILE:

Replying to your letter (1,143) as regards the "Position of Automobile Headlights," the writer has experimented as to the best place to carry the gas headlights, and, after trying all positions, we have found that where they are now put is, everything considered, the proper place.

The fault your correspondent speaks of, that is, of magnifying small inequalities, is caused by the rays from his lamp striking the ground at too much of an angle, and if he will tilt his lamp upward this defect will disappear.

The idea of placing lamps on the fender is all right, provided the lamp is placed so that the rays do not strike the fender. If they do, one will have a nice large shadow reproduction of the fender, that is anything but a help.

Manufacturers and users are not at all careful about "truing" up lamp brackets. We have noticed a great many cars driven by men who ought to know better, with headlights pointing anywhere than where they should. The proper way to "true up" headlights is to drive to within 25 feet of a blank wall and then adjust lamp brackets so that the lamps will throw the rays straight ahead.

Amesbury, Mass.

GRAY & DAVID.

### H. A. KNOX TALKS TO A. C. A. ON TWO-CYCLE.

At the Automobile Club of America on Tuesday evening last, Harry A. Knox, president of the Atlas Motor Car Company, of Springfield, Mass., delivered a lecture on the subject of the two-cycle motor and its possibilities on the automobile, particularly with reference to the Atlas motor which his company builds, and which has proved very successful. In the gathering were many of the pioneer members of the club who, in the past seven or eight years, have had experience with almost every type of automobile built, so that when President Colgate Hoyt introduced Mr. Knox, he found an attentive and well-informed circle of listeners. The lecture was more in the nature of an informal talk than a set technical paper on the subject of the two-cycle motor, and Mr. Knox illustrated his points with the aid of the component parts of one cylinder of an Atlas motor.

Mr. Knox concisely pointed out the advantages and disadvantages of the two and four-cycle types by impartially comparing them, and showing that while the former had not, up to recently, rewarded the efforts of investigators as they had anticipated, this did not affect the possibilities of the two-cycle motor, and that it only required the proper application of its principles to reap the numerous benefits of simplicity and efficiency which this type held out. Numerous questions were asked of the lecturer, which led to a very interesting discussion.

### OLDSMOBILE "MUDLARK" PLUGGING SOUTHWARD.

COLUMBUS, O., Jan. 31.—Ralph Owen, who is driving his 40-horsepower Oldsmobile *Mudlark* on the 2,000-mile midwinter trip from New York to New Orleans, arrived here to-night covered with mud from tires to top. Owen reports the roads from Buffalo to Cleveland to have been almost impassable owing to snow banks and ice driven into the roadway from the frozen surface of Lake Erie. This is the first automobile to attempt the trip to New Orleans from any of the Northern cities.

Owen left last Sunday, and expects to arrive in New Orleans February 14. If the schedule which he has been able to maintain up to date is approximated from now on he will be able to finish the 2,000 miles by that date. The *Mudlark* is fitted with Diamond tires.

### AN ANTI-AUTO RACING N. Y. ASSEMBLYMAN.

ALBANY, N. Y., Feb. 5.—Assemblyman Yale, of Putnam County, to-day introduced a bill repealing sub-division 6, article III, of the present motor vehicle law, which provides that "local authorities may, notwithstanding the other provisions of this act, set aside for a given time a specified portion of the highway for speed tests and races." Assemblyman Yale says State Engineer Skene favors the bill on the ground that racing automobiles tear up the good roads.

Assemblyman Fowler, of Ulster County, has introduced a bill providing for an annual registration fee, based on the weight of a motor vehicle, such rate to be 50 cents per 100 pounds.

### TAXICAB SERVICE FOR THE CAPITOL CITY.

WASHINGTON, D. C., Feb. 2.—Application has been made to the District Commissioners by the Thomas Taxicab Company for a license to operate a system of taximeter automobile cabs in this city. Robert A. Parke, who represented the E. R. Thomas Motor Company, of Buffalo, N. Y., is spending several days in Washington, in order to formulate plans for the proposed service, and it is expected E. R. Thomas will be here during the week to assist in the work. The system will be put into operation about March 1, if the company meets with no opposition.

### LONG ISLANDERS TO HOLD ECONOMY RUN.

BROOKLYN, Feb. 4.—A one-day midwinter economy test from Brooklyn to Montauk and return will be held by the Long Island Automobile Club on Tuesday, February 25. Gasoline and lubricating oil will be supplied in sealed cans to each contestant at a price basis of 25 cents per gallon for the former and \$1 for the latter. The winner will be the car which carries its full quota of passengers and official observer over the 242 miles at the lowest cost for each person, fuel and oil only to be considered. A comparison with railroad rates will be made. There will be no penalties for repairs or adjustments on cars or tires, but contestants must conform to a time limit to be determined the night before according to road conditions. Entry fee is \$25 for the first, \$15 for the second, and \$10 for the third car, entries closing on February 20, or at 6 P. M. on February 24, on payment of a penalty of \$10. The club reserves the right to abandon the contest if at least 25 entries have not been received at the regular time of closing, or to postpone the run if snow on the road should made them impassable. Final instructions will be given at a meeting of contestants and officials at the L. I. A. C. clubhouse. Cars may be left in the garage all night if desired. The contest committee consists of Arthur R. Pardington, chairman; C. G. Arnold, and F. D. Bاندell. Russell A. Field, the club secretary, announces that the entry blanks will be published immediately, and can be obtained at club headquarters, 360 Cumberland street, Brooklyn, or will be mailed to intending entrants upon request.

### C. L. GOODHUE NOW HEADS KNOX COMPANY.

SPRINGFIELD, MASS., Feb. 3.—The long-anticipated reorganization of the Knox Automobile Company, of this city, which made a voluntary assignment for the benefit of its creditors in July, 1907, was effected at a meeting of the directors on February 1. As a result Charles L. Goodhue was elected president, succeeding E. H. Cutler, while William E. Wright was reelected vice-president. Mr. Goodhue was also elected treasurer of the company, succeeding Albert E. Smith, who resigned from the directorate, together with E. H. Cutler, H. F. Farr and G. W. Bennett. The new directors are Charles H. Beckwith, Alfred N. Mayor, Charles L. Goodhue, Peter Murray and William E. Wright, Springfield; Clarence E. Whitney, Hartford; W. H. Chase, Leominster; M. J. Greenwood, Gardner, and H. W. Cutler, North Wilbraham.

The company's assignment was brought about by a lack of capital and the pressing need for ready money at the time, and the plan for reorganization includes the issuance of \$500,000 in preferred stock to the creditors of the company, which is practically a capitalization of the concern's indebtedness. Conforming to this plan, the management has been handed over to the preferred stockholders, or, in other words, the creditors, which accounts for the numerous changes in the officers and directorate. Alfred N. Mayo has acted as trustee for the company since the assignment, and there has been a considerable increase in its sales during the interim, so that a larger business than ever is confidently anticipated during the coming year, now that the temporary financial tangle has been settled to the satisfaction of all concerned.

### MANAGER APPOINTED FOR AUTO CARNIVAL.

Thomas Francis Moore has been appointed manager of the automobile carnival which the New York Automobile Trade Association intends to hold during the week beginning April 6. The appointment was made at a recent meeting of the association at the Hotel Cumberland. Features of the carnival already decided upon are a parade on Tuesday, April 6, and various gymkhana games and contests.



FRANKLIN NON-STOP CAR ON A MARYLAND ROAD.

### FRANKLIN MAKES A COLD-WEATHER RUN.

WASHINGTON, D. C., Feb. 3.—New honors have just been won by a Model Franklin in completing a 96-hour non-stop run, 500 miles of which was made on the road and the remaining 1,300 miles in the garage. At 11:34 o'clock, Tuesday morning, Jan. 28, the car left the city and covered the route of the recent sealed bonnet contest of the Automobile Club of Washington, which embraces 125 miles of road that is in very poor shape when the weather is bad. At the conclusion of each day's run the car was placed in a glass case in the garage of the Cook & Stoddard Company, Franklin agents, and there were various shifts of observers to see that the engine was kept running. The car was piloted alternately by J. H. Dailey, holder of the San Francisco-New York and Chicago-New York records, made in Franklin cars, and F. S. Bliven, of the Cook & Stoddard Co.

During the course of Friday's run Dailey was unfortunate to encounter a farmer riding a horse. The latter became scared at the car and proceeded to bolt. The car was stopped and Dailey tried to pacify the farmer. The latter insisted on his stopping the engine, but as this would defeat his project, Dailey declined to accede. A constable arrested the entire party and took them to Lima, Md., where a magistrate fined Dailey \$47 and costs, but the latter telephoned the State's Attorney. He advised the magistrate that he had exceeded his rights and that the highest fine he could assess was \$5 and costs. At the expiration of the ninety-sixth hour President Caverly of the Automobile Club of Washington formally brought the run to an end.



NEW 12-CYLINDER MAXWELL CHALLENGER WITH DESIGNER MAXWELL AT WHEEL.

### THE GOODRICH GIRL FOR 1908.

"Sally is an heiress," that is the Goodrich Sally, who is the charming feminine representative that the Akron rubber house greets its friends with every year. The original is done in oil, and the large size reproductions on heavy plate paper ready for framing that are sent out by the B. F. Goodrich Company are quite worthy of the large and annually increasing family of Goodrich girls. To quote from the company's announcement, it may be added that "Sally is heiress to a mint of suggestions (all Goodrich rubber)."

### WHERE PREST-O-LITE TANKS ARE CHARGED.

Plant Number 5, while not the latest addition to the manufacturing facilities of the Prest-O-Lite Company, is a recently completed building put up by this firm at Indianapolis, Ind. The building measures 200 by 700 feet, and is two stories high, besides a basement, thus giving 28,000 square feet of available floor space. The construction throughout is of the latest type of steel and reinforced concrete, thus making



PREST-O-LITE FACTORY NO. 5, AT INDIANAPOLIS.

it absolutely fireproof. It has been in operation since the beginning of the year and is one of the largest of its kind in the country, having a capacity of 2,000 Prest-O-Lite acetylene gas cylinders daily.

### TWELVE-CYLINDER MAXWELL AFTER FREAKS.

The twelve-cylinder 180-horsepower Maxwell racer is out for a special test of speed against all comers. The Sir Thomas Dewar trophy race would have given the opportunity desired, had that event been retained on the Ormond-Daytona program. This speed test having been withdrawn, the Maxwell-Briscoe people have written to Robert Lee Morrell, chairman of the contest committee of the A. C. A., asking him to issue a challenge on their behalf to the Stanley steamer or any other fast car, for a race to be held either during or immediately after the Florida beach tournament. It is declared that, with the consent of the trophy trustees, the twelve-cylinder Maxwell will be held in readiness at any time during the meet to start against all comers.

## BRIEF ITEMS OF NEWS AND TRADE MISCELLANY

Beck & Clausel, 204 Cox avenue, Memphis, Tenn., are about to put a new car on the market after designs of A. C. Menges, late of Grand Rapids, Mich., and though all details have not been definitely settled a four-cylinder car of medium price, high power and light weight will be made.

The Detroit branch of the G & J Tire Company will remove at once from 247 Jefferson avenue to 256 Jefferson avenue and occupy part of the Hartford Rubber Works Company branch store at that number. The individuality of the two concerns will, of course, be maintained, H. C. Severance continuing as manager of the Hartford Rubber Works Company and Charles S. Monson of the G & J Tire Company.

Holsman cars are not built primarily for speed, but that they can hold up their end in this respect when necessary is amply evidenced by the fast trip from Winslow, Neb., to Fremont, made by President Weitkamp of the Bank of Winslow recently. He left Winslow in his Holsman a few minutes after the departure of the regular train and succeeded in overtaking it, covering the distance of fourteen miles between the two towns in thirty-five minutes.

During the past week or so there has been a rumor abroad to the effect that the Hartford Rubber Works Company, Hartford, Conn., contemplated closing their branch houses in Buffalo and Cleveland, and in some instances the rumor had it that this was already an accomplished fact. The company makes haste to brand the report as entirely unfounded, and states that there is no intention of taking any such action, nor has the matter come up for consideration.

The C. A. Shaler Company, of Waupun, Wis., have just made shipment through C. B. Richard & Company, custom house brokers, 31-33 Broadway, New York City, of ten cases of their Shaler electric vulcanizers, which is the first of such shipments which are to be made monthly during 1908, to one of their largest foreign accounts, Armand Frey & Co., Behren Strasse 47, Berlin, Germany. This order for 120 cases is a direct result of the Madison Square Garden Show.

The Hess-Bright Manufacturing Company, of Philadelphia, has found it necessary to make a third change to larger quarters and will shortly occupy a four-story building, with a floor space of 15,000 square feet, exclusive of the basement, which is given up to a modern gas producer power plant. Aside from the DWF ball-bearing division, this is the largest plant devoted exclusively to the manufacture of ball-bearings of only one grade, that of the annular type. The new quarters will be occupied some time within the next six weeks.

When Nelson S. Riley, of New York, went to Honolulu last fall, he bought a new Studebaker "30" car from the Studebaker branch in San Francisco and took it with him to the islands. The machine attracted a good deal of attention in Hawaii, especially as it was the first car ever seen there employing the "make and break" system of ignition. Mr. Riley writes that the quiet running qualities of his car have been particularly commented upon and its noiselessness has earned for it the name of "the gliding car."

A preliminary injunction has been issued by the U. S. Circuit Court, Southern District of New York, against the Motor Car Equipment Company, of New York City, forbidding them to make or sell lamps in imitation of the Rushmore Flare Front searchlights and headlights; also to use the words "Flare Front" or the name Rushmore in describing their product. This injunction is in line with the one lately issued against the Manhattan Lamp Works. Actions will shortly be brought against a number of other concerns for injunctions and an accounting.

The Brush-Detroit Motor Company, 255 Jefferson avenue, Detroit, according to a letter just received by THE AUTOMOBILE, does not believe that the times are particularly hard. States Manager P. R. McKenny: "We are doing phenomenally well in our new quarters, having sold twelve cars in less than four weeks, some of these for immediate delivery and the balance for early spring delivery. We are still getting replies from our last advertisement in your publication, and they all seem to be good prospects." This company sells the Brush \$500 runabout.

Further important additions are about to be made to the building and manufacturing equipment of the Rambler factory which has been for years one of the largest exclusive automobile plants in the world. Within the past two weeks six more acres of ground, adjacent to the factory in Kenosha, have been purchased by Thomas B. Jeffery & Company. The ground area now measures one-half mile from east to west and one-half mile from north to south. This factory has been in operation every single working day since 1900 and each year the capacity of the factory has been considerably increased.

"A car a day has been the record of the shipping room of the F. B. Stearns Company since early in December, and this pace bids fair to continue until the 1908 stock is exhausted," say the makers. "The market seems to be easing up steadily, and the prospects for a good selling season are better right now than they were at this time last year, which is saying a good deal. A visitor to the Stearns factory is more than impressed by the way work is being rushed, and the full night shift is still hard at it. Talk of the recent 'near-panic' has not affected this plant any more than scores of others turning out really high-grade machines."

The continental touring service which has been conducted by E. B. Gallaher, of 228 West Fifty-eighth street, New York City, has been transferred by arrangement to the Maja Company, Ltd., for which Mr. Gallaher is director and American manager. In addition to the branches maintained at Havre, Southampton, Liverpool, London, Stuttgart, Genoa, and Bremen, additional agencies will be opened in connection with the Maja branches at Hamburg, Paris, and St. Petersburg. The service inaugurated by Mr. Gallaher has been decidedly helpful in its work of furnishing information and service in the matters of shipping, repairs, licenses, regulations, road maps and many other details. Its effectiveness will be largely increased under the new arrangement and as the entire organization of the Maja Company, Ltd., will be available.

The selling force of the Meek Company, dealers in leather goods and advertising specialties, Coshocton, O., has been sent on an unusual continental automobile tour. The entire force was supposed to leave the factory on an imaginary tour to the Pacific Coast, following the general direction of the Northern Pacific Railroad, and returning by the route of the Southern Pacific. One hundred towns, which for convenience have been called 100 miles apart, have been placed on the route. Each man is supposed to have some well-known make of automobile, the progress of which is determined by amount of sales. A perfect day carries him 100 miles; a perfect week a further advance. The salesman to return to Coshocton first receives the most valuable prize. There are six lesser prizes.

### NEW AGENCIES ESTABLISHED.

The American branch will open a Boston office and salesroom at 885 Boylston street, Boston, for the handling of Fiat cars. S. H. Baker will be in charge.

The Bartlett-Jacobs Company, No. 887 Boylston street, Boston, in addition to the Allen-Kingston agency, has added the Mercedes and De Dietrich cars for Boston and vicinity.

Joseph M. Gilbert, general manager of the Continental Caoutchouc Company, announces that two more distributing agencies have just been added to agency representation of his concern. They are the Long Island Auto Supply Company, 1249 Bedford avenue, Brooklyn, and the Acme Rubber Company, Toledo, O.

Renault branches on the Pacific Coast will in future be handled directly by the Renault Frères Selling Branch's own establishment at 316-322 Van Ness avenue, San Francisco. Paul Lacroix, general manager for the Renault in America, has just completed arrangements.

The Palmer & Singer Manufacturing Company, of New York City, have just added to their already very representative line of cars, the new Selden 28-horsepower car to sell at \$2,000, which will give them one of the most complete price ranges that almost any agency house in the country can boast. They will control the Selden throughout Greater New York. Rose & Thompson, proprietors of the Yonkers Auto Station, will handle the Selden in that city. Mr. Rose was formerly associated with E. T. Birdsall, the designer of the Selden, in the old Decauville Company.

### PERSONAL TRADE MENTION.

J. S. Draper, for the past three years sales-manager of the Wayne Automobile Company, Detroit, Mich., has just resigned that position to assume the duties of general sales-manager of the Mora Motor Car Company, of Newark, N. Y. Mr. Draper's resignation became effective on February 1.

Roy D. Chapin, treasurer and general manager of the E. R. Thomas Detroit Company, is now making a trip to the Pacific Coast in the interests of the latter. A considerable business in Thomas Detroit cars is done in the Far West and particularly on the coast, and as Mr. Chapin is well and favorably known there he is expected to make a very successful trip.



**INDEX TO ADVERTISERS**

Acetylene Gas Illuminating Co. 61	Cowles & Co., C. 60	Jeffery-Dewitt Co. 61	Prest-O-Lite Co. 70
Acme Motor Car Co. 66	Crown Soap Co. 71	Jenckel Motor Mfg. Co. 71	Progressive Mfg. Co. 72
Adams Co. 66	Cullman Wheel Co. 64	Jenkins Specialty Mfg. Co. 78	Prosser & Sons, Thos. 64
Add-Wear Auto Tire Sleeve Co. 67	De Luxe Motor Car Co. 66	Jones Speedometer 61	Quinby Co., J. M. 65
Aero & Marine Motor Co. 73	Detroit Steering Wheel Co. 86	Johnson Sporting Goods Co., I. 65	Ralmes & Co. 60
Aerocar Motor Co. 108	Diamond Chain & Mfg. Co. 91	K. W. Ignition Co. 62	Rainier Co. 67
Ajax-Grieb Rubber Co. 67	Diamond Rubber Co. 95	Kimball Tire Case Co. 70	Rauch & Lang Carriage Co. 93
Am. Brass & Alum. Works. 64	Dietz Co., R. E. 92	Kokomo Electric Co. 94	Reeves Pulley Co. 68
American Distributing Co. 99	Dixon Crucible Co., Joseph. 74	Konigsloew, Otto 64	Reliance Motor Car Co. 84
American Locomotive Motor Car Co. Cover	Dorris Motor Car Co. 75	Koontz, J. H. 74	Remy Electric Co. 61
Anderson Forge & Machine Co. 64	Dover Co., Geo. W. 59	Lansing-Mahon Press 75	Richardson Engineering Co. 65
Angler Co. 78	Dover Stamping & Mfg. Co. 76	Lavalette & Co. 61	Robert Instrument Co. 61
Apperson Bros. Automobile Co. 85	Dow Portable Electric Co. 61	Learn Automobile Co., Oscar. 66	Robinson & Sons Co., Wm. C. 65
Ashtabula Bow Socket Co. 55	Eastern Carbon Works. 71	Leather Tire Goods Co. 67	Rock Island Tool Co. 71
Atlas Motor Car Co. 90	Echo Horn Co. 84	Lipman Mfg. Co. 60	Ross Gear & Tool Co. 64
Atwood Mfg. Co. Cover	Eclipse Machine Co. 60	Lobe Pump Co. 62	Rothschild Co. Cover
Auburn Automobile Co. 66	Edgar Mfg. Co. 60	Locke & Co. 87	Royal Equipment Co. 61
Audel & Co., Theo. 68	Edmunds & Jones Mfg. Co. 60	Locomobile Co. of America. 85	Rubay, Leon 76
Aurora Motor Works. 77	Eldredge Electric Mfg. Co. 62	Logan Construction Co. 66	Rushmore Dynamo Works. 97
Auto Pump Co. 68	Ellsworth, J. M. 101	London Auto Supply Co. 65	Salisbury Wheel & Mfg. Co. 60
Autocar Co. 85	Elmore Mfg. Co. 93	Long Mfg. Co. 73	Samson Leather Tire Co. 67
Autocar Equipment Co. 75	Empire Automobile Tire Co. 93	Macbeth-Evans Glass Co. 87	Sanford Mfg. Co., F. C. 64
Automobile Supply Co. 60	Empire Wheel Works. 65	Mandeville Steering Wheel Muff Co. 69	Saxon Lamp Co. 61
Automobile Utilities Co. 61	Excelstor Supply Co. 72	Maple City Mfg. Co. 70	Schacht Mfg. Co. 96
Auto-Shine Co. 62	Fairmount Engineering Works 66	Mason, John A. 65	Selden Motor Vehicle Co. 111
Auxiliary Spring & Ventilating Button Co. 65	Firestone Tire & Rubber Co. 67	Manhattan Electrical Sup. Co. 61	Shawver Co. 62
Avery Portable Lighting Co. 71	Flisk Rubber Co. 86	Manhattan Storage Co. 63	Smith Mfg. Co., R. H. 63
Baker Motor Vehicle Co. 66	Forest City Motor Car Co. 82	Masury & Son, John W. 77	Spare Motor Wheel of Am. 97
Baldwin Chain & Mfg. Co. 61	Fort Pitt Motor Car Co. 83	Mathewson Motor Car Co. 88	Speed Changing Pulley Co. 69
Barnrd-Johnson Auto Sup. Co. 65	Franc-Am. Auto Supply Co. 60	Mayo Radiator Co. 64	Splcer Universal Joint Mfg. Co. 64
Barnett Drop Forging Co. 76	Franklin Mfg. Co., H. H. 109	Merchant & Evans Co. 73	Spittdorf, C. F. 61
Beaver Mfg. Co. 61	Fry, T. C. & W. L. 60	Merritt & Co. 60	Springfield Metal Body Co. 65
Behen-Faught Motor Car Eq. Co. 61	G & J Tire Co. 69	Meyer & Son, E. G. 65	Springfield Portable House Co. 73
Beloit Supply Co. 92	Garford Motor Car Co. 66	Michelin Tire Co. 89	Standard Automatic Lub. Co. 61
Bemus, T. Alton. 74	Gearless Transmission Co. 85	Middley Mfg. Co. 64	Standard Co. 92
Blasier Mfg. Co., M. E. 65	Gelszler Bros. 62	Miller, Chas. E. 80	Standard Roller Bearing Co. 64
Bliss-Chester Co. 60	Gemmer Mfg. Co. 71	Mitchell Motor Car Co. 66	Standard Welding Co. 80
Blomstrom Mfg. Co. 74	General Accumulator & Battery Co. 61	Model Automobile Co. 66	Stanley, John T. 86
Boker & Co., H. 62	Gibney & Bros., Jas. L. 61	Molne Automobile Co. 96	Steam Carriage Boiler Co. 62
Borbein Automobile Co. 74	Gilbert Mfg. Co. 72	Monarch Motor Car Co. 66	Stearns Co., F. B. 67
Bosch, Robert 90	Gordon Automobile Supply Co. 76	Moon Motor Car Co. 66	Stevens-Duryea Co. 89
Boston Auto Gage Co. 68	Graves & Congdon Co. 78	Morgan & Wright. 94	Stewart & Clark Mfg. Co. 72
Bowers Co., F. E. 72	Gray & Davis. Cover	Mosier & Co., A. R. 62	Stitch-in-Time Vulcanizer Co. 68
Bowser & Co., S. F. 68	Gray-Hawley Mfg. Co. 75	Moss Photo Engraving Co. 106	Strelt Machine Co. 61
Boyle & Co., John. 98	Grout Bros. Auto Co. 82	Motor Car Co. 79	Studebaker Automobile Co. 75
Brennan Motor Co. 82	Hans, Edmund E. 79	Motor Car Equipment Co. 68	Success Auto Buggy Co. 67
Bridgeport Vehicle Co. 69	Hardy Co., The R. E. 62	Motz Clincher Tire & Rub. Co. 67	Supplementary Spiral Spring. 95
Brown, Wm. W. 60	Harris Oil Co., A. W. 61	Muller, Albert 78	Swinehart Clincher Tire Co. 78
Brownell Motor Co., F. A. 92	Hartford Suspension Co. 62	Mutty Co., L. J. 65	Syracuse Umbrella Co. 80
Brush Runabout Co. 83	Hatfield Motor Vehicle Co. 66	Myers Auto Top Co. 65	Thomas Motor Co., E. R. 105
Buckeye Jack Mfg. Co. 73	Haynes Automobile Co. 66	N. Y. & N. J. Lubricant Co. 94	Thompson Sons Co., J. P. 69
Buckeye Mfg. Co. 66	Healy Leather Tire Co. 67	National Auto Accessories Co. 61	Timken Roller Bearing Axle. 100
Buffalo Carbureter Co. 104	Heinze Electric Co. 80	National Battery Co. 76	Tray Plate Battery Co. 78
Bullard Automatic Wrench Co. 80	Hercules Auto Specialty Co. 77	National Motor Vehicle Co. 88	Trebert Gas Engine Co. 67
Bullard Specialty Co. 93	Herz & Co. 71-73-75-79	Neustadt Auto & Supply Co. 82	Tucker, C. F. 60
Buod & Scheu. 65	Hess-Bright Co. 64	Never-Miss Spark Plug Co. 61	Turner Brass Works. 64
Cadillac Motor Car Co. 66	Hicks Speed Indicator Co. 100	New Process Rawhide Co. 94	Uncas Specialty Co. 74
Cameron Car Co. 66	Hine-Watt Co. 67	Nordyke & Marmon Co. 66	Veeder Mfg. Co. 87
Canton Drop Forge & Mfg. Co. 64	Hoffecker Co. 60	Northway Motor & Mfg. Co. 70	Walker Mfg. Co., E. C. 68
Champion Co., A. 96	Hoffman, Geo. W. 60	Nuttall Co., R. D. 64	Warner Instrument Co. 103
Chelsea Clock Co. Cover	Holley Bros. Co. 95	Ofeldt & Sons. 60	Warner Pole & Top Co. 65
Clark, E. S. 60	Holsman Automobile Co. 83	Olds Motor Works. 67	Watt-Detroit Carbureter Co. 93
Cleanola Co. 70	Hopewell Bros. 67	Pacific Tucking & Mfg. Co. 60	Waukesha Motor Co. 76
Coes Wrench Co. 56	Hotel Gibson 81	Packard Electric Co. 61	Wayne Automobile Co. 67
Comptoir d'Innovations pour Automobiles 79	Hotel Gilsey 80	Packard Motor Car Co. 110	Weed Chain Tire Grip Co. 69
Connecticut Steel & Wire Co. 65	Hotel Pterrepoint 81	Palmer & Singer Mfg. Co. 67	Welch Motor Car Co. 75
Conn. Tel. & Elec. Co. 87	Hotel Piney Woods Inn. 81	Parish & Bingham Co. 64	Western Motor Co. 73
Continental Caoutchouc Co. 67	Hotel Richmond 81	Parker, Stearns & Co. 73	Weston Elec. Instrument Co. 84
Continental Motor Mfg. Co. 67	Hotel Tampa Bay. 81	Penn. Auto Motor Co. 67	Wheeler & Schebler. 103
Corbin Motor Vehicle Corp. 75	Hotel Tuller 81	Pease & Sons, S. E. 65	White Co., The. 102
Corcoran Lamp Co. 69	Howard Motor Works. 66	Perfection Grease Co. 73	Whitney Mfg. Co. 76
Cornish-Friedburg Motor Car. 66	Hoyt Electrical Inst. Works. 91	Peugeot Freres 64	Winton Motor Carriage Co. 112
Correspondence School of Motor Car Practice. 66	Hub Lubricator Co. 76	Pfanzstiel Elec. Laboratory 60	Witherbee Igniter Co. 65
Cotta, Chas. 68	Hyatt Roller Bearing Co. 76	Pierome Hide Co. 64	Wyman & Gordon Co. 59
	Hydraulic Pressed Steel Co. 64	Pierce Engine Co. 67	Wing Co., Chas. 65
	Imperial Motor Car Co. 66	Pioneer Brass Works. 64	Weeber Mfg. Works, C. F. 61
	Indestructible Steel Wheel Co. 62	Pirelli & Co. 67	York Motor Car Co. 84
	Index Speed Indicator Co. 61	Portland Garage 62	
	Jackson Automobile Co. 66	Precisior Appliance Co. 61	
	Jeffery & Co., Thos. B. 107	Premier Motor Mfg. Co. 99	

FOR UNMATCHABLE QUALITY BUY

**COES** 91

STEEL HANDLE MODEL WRENCH 91

**THE WRENCH for Automobilists**

High-grade quality in every detail of design, material, workmanship and up-to-date improvement. Excellence with extremely reasonable cost.

- NON-BREAKABLE CASTINGS
- NON-STRIPABLE THREADS
- NON-TROUBLESOME PARTS

**QUALITY**  
Through and Through.

Look for the name—COES



70 years splendid reputation worthily maintained right up to the present time as the World's Best Wrench Makers. Write for "Wrench Book" free.

**COES WRENCH CO., WORCESTER MASS.**

# THE AUTOMOBILE

## ACROSS THREE CONTINENTS BY AUTOMOBILE

TO the accompaniment of a mad, hooting, shouting, honking and cheering in various languages, seven automobiles and twenty men have left New York for Paris on the Western trail. The majority of those who gathered round Colgate Hoyt in Times Square to witness the start Wednesday morning said the scheme was a mad, impossible one; among the contestants each man declares that the other fellow will never do it. Questioned individually, each team considers it has just the combination of units essential for a journey of 20,000 miles across America, through Alaska, over the Behring Straits, Siberia, Russia, and Europe to Paris.

France, America, Germany and Italy, the former with four, the others with one unit each, are the active participants in the round-the-world trip which every country on the globe is watching with more or less interest. France has four cars; officially she has but three. A few months ago, soon after the Pekin-Paris run which the world declared a mad scheme, but which every contestant but one accomplished, a soldier-sailor stepped into the *Matin* office in Paris and proposed a round-the-world trip via New York and the Behring Straits. The man was M. Lelouvier, the hero of a thousand

adventures, whose life story reads more like a page from a boy's book of adventures than a narration of twentieth century facts; a man who had passed his life playing with death.

Lelouvier's suggestion was adopted, *Le Matin* obtained the collaboration of the *New York Times*, and the run was announced. But the originator of the idea had his own views

on how such an event should be conducted, preferred a route which he had traveled on foot and by sleigh, and refused to depart from it despite the advantages of an organization backed by two powerful journals. Tuesday he set out alone, unsupported by other than his own forces, but none the less resolved to work a way through to Paris. The official contestants then are: Thomas, 60-horsepower (America), Montague Roberts, M. Garchard; De Dion, 30-horsepower (France), Captain H. H. Hansen, M. Autran, G. Bourcier St. Chaffray; Motobloc, 28-30-horsepower

(France), M. Godard, M. Hue, M. Livier; Sizaire-Naudin, 15-horsepower (France), Paul Pons, M. Berthe, M. Deschamps; Züst, 28-30-horsepower (Italy), Antonio Scarfoglio, Emilio Sartori, Henri Haaga; Protos, 40-horsepower (Germany), Lieut. Koeppen, Engineer Hans Knape, Engineer Ernest Mass, on special leave from the German army.



PARTICIPANTS ABOARD "LORRAINE."



ENTHUSIASTIC DEPARTURE OF DE DION CAR FOR HAVRE, PASSING THROUGH THE BOULEVARD DE LA MADELEINE, PARIS.



LELOUVIER AND THE WERNER, WORLD'S TOURING CANDIDATE.

The general manager and organizer of the trip, the man on whom all the responsibility of detail work has fallen, is G. Bourcier St. Chaffray, the *Matin* delegate, who will travel as passenger in the De Dion car as far as Alaska. Captain Hans Hendrick Hansen is a Norwegian with long experience in Siberia and the Arctic regions. The equipment of the car for the ice regions has been left entirely in his hands, and has been worked out in a marvelously clever manner. "It needs grit to go on a trip like this," said one observer at the starting line. "No, it doesn't," rejoined Hansen, "it needs thought; thousands of men have grit, but that won't carry you through the Arctic regions. You must have a well-thought-out and carefully prepared scheme. Questioned further, the Norwegian explorer said: "My plan is to jog along over the United States in an easy manner; I shall not race if every automobile in America urges me on. It is when we get to East Cape that the struggle will begin, and we shall need all our strength. For an entire month there will not be a moment's rest for man or machine, for I intend to run continuously. A searchlight will enable us to travel almost as easily by night as by day, and when we come to the long frozen stretches we shall hoist sail and run under auxiliary power. I have done this for hundreds of miles in Siberia and know what to expect." Captain Hansen is not an expert automobilist, but he has with him M. Autran, a Frenchman, the crack mechanic of the De Dion factory.

Roberts, the American driver, has been too much before the public during the last two years to need introduction. Unfortunately his engagements in the East prevent him going through to the end, and he will probably leave the party at San Francisco. M. Garchard will accompany him.

Godard, the driver of the Motobloc, is a devil-may-care



SIZAIRES NAUDIN AND DE DION-BOUTON, WORLD'S TRAVELERS.

Frenchman who made the journey from Peking to Paris last year on a Spyker, a trip, he declares, quite good enough to prepare a man for a round-the-world jaunt. His two companions are both skilled mechanics. Paul Pons, a thin, wiry man who drove a tricar out from Peking, says lightweight will carry him through. In addition to a mechanic, he has with him a Pathé cinematograph operator. Züst is all-Italian, Scarfoglio, Sartori and Haaga all experienced motorists, trained to hardship, but with no special experience in Arctic regions. Germany has sent a full military team for the Protos car, the three army officers being splendid examples of physique, drilled to hard service and recently trained for automobile work.

It is exceedingly doubtful if the United States will be crossed from East to West. Owing to the late start and the fear of arriving in Alaska during the thaw, it will probably be necessary to ship the cars on the train at Ogden or Cheyenne and run them direct to Seattle, where they will be carried by boat to Valdez, Alaska. Though this will break the run, the contestants believe that it is preferable to lose a few miles in America rather than run the risk of making the journey impossible by too late arrival in Siberia. The real test, indeed, will not commence until Nome



ST. CHAFFRAY, HANSEN, AND AUTRAN, OF DE DION PARTY.

has been reached. From New York the run is to Albany, Buffalo, Cleveland, Toledo and Chicago.

#### How the Cars Are Equipped for the Journey.

Though each contestant believes that his own special type of stock chassis is the most suitable for the round-the-world trip—and in not one single case has a special machine been built—ideas are varied as to the best type of equipment for a journey through Arctic regions never before invaded by an automobile. Of the seven contestants the De Dion certainly stands out as the one most carefully prepared and equipped for the task it has set out to accomplish. An ordinary 30-horsepower, four-cylinder chassis has been selected, and although having few external points of resemblance with the factory's ordinary product, it is as a matter of fact unchanged in any mechanical feature. The machine used, indeed, is one of those which took part in the Coupe de la Presse tour and race last August, one of the essential conditions of which was conformity with stock standards.

The frame has been filled with soft wood, wrapped in felt, and finally covered with rubber. Axles, springs, steering column, and in fact every exposed metal part subject to strains has been treated in this way, Captain Hansen declaring such protection essential to preserve the steel from the effects of extreme cold. The only change on the engine is the raising of the exhaust manifold with a view to keeping

the temperature under the bonnet a little higher than usual. A pan the full length of the chassis protects the underworks, but makes the road clearance rather small for a journey over virgin country. Seven independent gasoline tanks, with a total capacity of 154 gallons, are carried immediately above the frame from the driver's seat rearward. All are stoutly encased, separated by partitions, and connected up separately to the carbureter, so that should one become disabled, only a small amount of precious fuel would be lost. Above the layer of tanks is what at first appears to be a square delivery body; on climbing up on the running board it is seen that a circular well has been left of just sufficient size to allow of the accommodation of spare tires, the center being the seat for the third man.

In the chests built round the well are spare parts, tools, clothing, a Nansen kitchen, sufficient food for one month, and the thousand and one things necessary for an Arctic exploration.

To prevent the water freezing a special preparation has been supplied to all the contestants, the nature of which has not been made public. If all works out in practice as in the laboratory tests, everything will be well; if not each driver will have to rely upon his own ingenuity. The Standard Oil Company is supplying to all contestants a special brand of lubricating oil guaranteed not to freeze under the most rigorous climate. De Dion, however, being an oil refiner, uses his own. Steel studded Michelin tires and Vinet dismountable rims are being used. On frozen snow or ice the rims will be dismounted and steel ones with sharp spikes will be substituted; where railroad tracks run through the country to be traversed, steel flange rims will be fitted, and the car run like a locomotive. Captain Hansen declares that for several hundreds of miles through the Arctic regions he will have a steady wind astern, and to take advantage of this will step a mast in front of the radiator and hoist a lug sail. Over soft snow long wooden runners will be attached to the front wheels, making the car practically an automobile sleigh.

Compass, sextant, charts and roll maps occupy convenient positions in front of the driver. A portable dynamo will be fixed up in such a position to be worked by one of the passengers during the journey, and being connected with storage batteries will lay up a supply of electricity for night traveling. It is believed that a hand operated dynamo, with suitable gearing, is preferable to one driven by the motor, for it will relieve the engine of a little work and serve to keep the operator warm. For the same reason the small but powerful windlass is worked by hand. Protection for the drivers is afforded by a stout leather

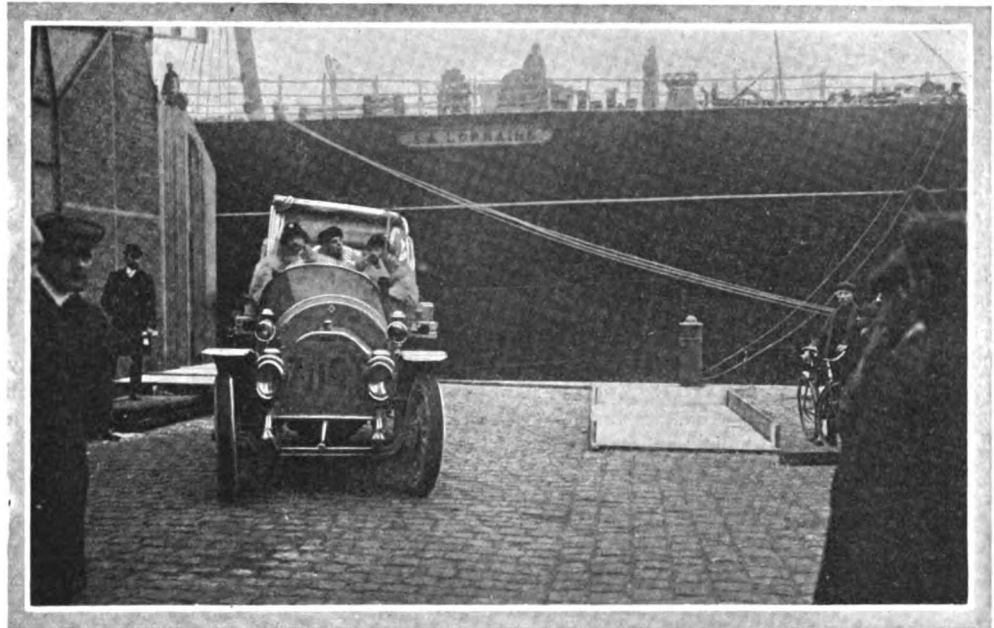

ZUST JUST BEFORE EMBARKING AT HAVRE ON THE "LORRAINE."

apron, a slight canvas wind shield with celluloid front, and a light folding hood covering the entire body. Enveloped in their Arctic sleeping bags, the men will take their rest in the snow—one of the most comfortable beds imaginable, declares the Norwegian explorer.

#### How the Only American Competitor Is Fitted Out.

Montague Roberts, America's only representative in the 20,000-mile trip, will have a standard 60-horsepower Thomas Flyer built at the Buffalo factory and fitted out under his supervision. Externally there are fewer departures from standard equipment than on any of the machines taking part in the tour, the car being the usual Thomas runabout with such necessary equipment as conditions suggest. Ordinary 36-inch wheels and tires will be used on the early part of the journey; later these will be changed for 40-inch wheels with solid tires, so designed that should the rubber wear out the machine can run on the steel rims. Spare tires are carried behind the rumble seat. Running the full length of the car, and each side of the vehicle, is a long wooden



MOTOBLOC CREW ADDING FINAL EQUIPMENT BEFORE DEPARTURE.



support to which the various parts of the equipment are attached and which will serve to work over rough road. Ninety gallons of gasoline are carried in the ordinary tank, and sixty gallons in the reserve tank. A winch is fitted to the front of the car and connected to the engine by coupling gear. Provision has been made for warming the driver by means of the exhaust gases, and protection will be afforded the men by a wind shield and a buggy hood.

Godard, who has aptly been termed the dare-devil of the party, declares that he put all the official instructions on how to prepare for the run into a bag as soon as they were received and has not opened the bag yet. The enthusiastic, irrepressible Frenchman made the run from Pekin to Paris and believes that he there learned enough to know how to fit his Motobloc for the New York-Paris expedition. A standard 24-30-horsepower chassis has been taken, fitted with a four-seated runabout body, and furnished with a large chest in the rear of such dimensions and arranged in such a way that everything required for the trip can be found when wanted. The standard gasoline tank at the rear of the chassis is retained, but it is admitted that it is doomed to be sacrificed, probably before America has been left, and reserve tanks have been fitted with a capacity of over seventy gallons. Tires used are a patent cushion type with multiple interconnecting air chambers. Spacious boxes on the running boards contain tools and such articles as are likely to be needed frequently on the run. The drivers are protected by a folding hood and a leather wind shield.

#### A One-lunger Will Invade the Arctic Regions.

A 20,000-mile run with no other power than that furnished by a tiny single-cylinder engine of four and a half inch bore appears the height of temerity; Paul Pons, the driver of the French Sizaire-Naudin declares that there is nothing extraordinary in it. When asked if his power is not too small, he smiles and replies in the vernacular—for though a globe trotter he has not learned to converse in any other than his own language—"Not a bit of it; if I have little power I have little weight; some of the other fellows have three or four tons to move over the country. In comparison I have nothing. I have a spare seat on the car, and if you know of any American who would like to make the trip, I shall be glad to take him along." Pons, who is a lightweight himself, has had experience with lightweight machines, being the driver who set out from Pekin on a tricycle last year with the intention of reaching Paris. His gasoline supply became exhausted, and his tricar is still rotting on the Gobi desert. A standard 15-horsepower machine has been selected, fitted with larger wheels, the frame filled with soft wood, and supplied with extra gasoline tanks capable of holding 33 gallons. As with all the French contestants using pneumatics, Michelin tires are employed. For cooling his engine Pons will try the non-freezing mixture supplied to all the contestants, but if this does not give absolute satisfaction will adopt pure kerosene, which he declares to be excellent.

Italy has a powerful-looking representative in the Zusta, said to house but 28-30-horsepower under its green, white and blue bonnet. A standard chain-driven model has been selected for the trip, unchanged in any mechanical feature. The frame has been filled with soft wood, the springs are wrapped with cord, but no other protection has been given to the chassis. Built up from the dash is a metal and canvas shield completely protecting the driver; as the sides are built round in the same way, the two men in the front seat operate in an almost entirely inclosed vehicle. Behind the two rear seats a series of metal chests have been built up, the lower ones containing gasoline tanks with a capacity of 100 gallons, the upper ones holding tools, equipment and food. There is room for three passengers on the seat behind the driver, but only one man will occupy it, the remain-

ing space being occupied by tires and stores. Pirelli pneumatic tires, an Italian production, have been selected.

Though an outsider, M. Lelouvier and his Werner car have to be reckoned with on the tour, any man willing to start on an expedition of this nature alone and unaided possessing more than ordinary qualities of assurance and determination. The machine selected is a composite, consisting of a 15-horsepower De Dion engine and a Lacoste & Battmann chassis. There being no fixed gasoline stations where Lelouvier can replenish his supply, he is under the necessity of carrying an extra large quantity along with him, and in addition must find room for all spare tires and parts that he may need before reaching Paris. To meet these difficulties he has prepared as many stations for himself as possible, his wife, at present in Siberia, personally looking after this part of the trip. Lelouvier has so often emerged safe and sound from positions in which he ought, according to all natural laws, to have met disaster, that he is looked upon as having a charmed life, and may be expected to pull through the New York-Paris run, despite the difficulties under which he works.

Sixteen days is the record time in which the Berlin factory built the four-cylinder 40-horsepower Protos car. Weighing 6,000 pounds, 196 inches in length, and 80 inches wide, it is one of the largest and most powerful looking vehicles on the run. The extra width has been given to allow the men to sleep on the floor of the car, and when the canvas hood is up it has much the appearance of an army wagon. The gasoline supply of 176 gallons is contained in six separate tanks. The car is shaft driven, has runners for the front wheels, steel spike rims for the rear, and uses Diamond tires where pneumatics are practicable.

#### Race to Carry American Flag to French Club.

During the farewell banquet offered by the Automobile Club of America to the contestants, an American flag was presented by President Hoyt to each of the teams. Immediately after the presentation Jefferson DeMont Thompson, chairman of the A. A. A. racing board, stated that he would give \$1,000 in gold to the first man presenting one of these flags to Baron Zuylen, president of the Automobile Club of France, on arrival in Paris. On the sportsmanlike offer being communicated to the teams through an interpreter, a cheer arose, and one of the Frenchmen exclaimed: "We shall present that flag." The triumphant flag will be returned to the A. C. A. to be preserved as a trophy.

#### CHICAGO CLUBS TO FIGHT NEW WHEEL TAX.

CHICAGO, Feb. 10.—Automobile associations in this city were fully prepared for the passage of the wheel tax ordinance which was passed by the City Council last week at the same time that the wide tire ordinance was put through, both being scheduled to go into effect on May 1 next, and the campaign against the former was immediately undertaken to prevent its being enforced, the legislative committee of the Chicago Motor Club, of which John McKeown is chairman, acting under instructions from Secretary G. G. Greenburg, taking steps to procure an injunction to prevent the municipal authorities from carrying out the provisions of the ordinance. The latter provides for a tax of \$5 on a one-horse vehicle, and a tax of \$12 on a two-passenger automobile, while the charge for a two-horse vehicle is but \$10 and that of an automobile seating more than two persons is \$20 annually. The charge for auto trucks and commercial cars is \$30. All the automobile organizations are united in their fight against the new ordinance, and in this they are backed up by the teaming interests. It is the consensus of legal opinion that the measure is clearly unconstitutional, this being founded in part upon the case of the City of Chicago vs. Collins in 175 Ills., which ended a similar attempt to tax bicycles, and it will be fought on this ground.

## A. M. C. M. A. IN SESSION RE-ELECTS BRISCOE AND REEVES

**D**ETROIT, Feb. 10.—Optimism was spelled with large letters at the annual meeting of the American Motor Car Manufacturers' Association, held at the Hotel Pontchartrain Saturday. Thirty-four of the fifty-two concerns enrolled were represented. And from each there came the same story, not for publication, necessarily; not for the purpose of overawing the layman, for there was little shop talk outside of the meeting.

But when the makers of motor cars settled down to discussion of the situation and compared notes on the outlook there was one verdict, and that was that in spite of the lull caused by the recent financial flurry the coming season will prove a good one. This conclusion is not speculative, but the result of a careful canvass of the field.

"Business never looked so good for the automobile manufacturer," said Chairman Briscoe. "This is particularly true of makers of medium-priced cars, whose popularity is constantly increasing. There is a practically unlimited field for machines of this type, and it is this trade that is a positive boon to the industry. The man who buys a high-priced car usually belongs to the class first to be affected by a tightening of the stock market. On the other hand, it has been the experience of the trade that purchasers of the more moderate priced machines belong to the conservative element, investing in a car not only for pleasure, but from the standpoint of utility. It is in this respect that the American Motor Car Manufacturers' Association, embracing as it does a majority of the makers of moderate priced cars, occupies an advantageous position. The last quarter of 1907 was quiet, owing to unsettled conditions in the money market, but everything indicates that the demand for automobiles this season will be fully up to the supply, with manufacturers enjoying one of the most prosperous seasons in the history of the industry."

General Manager Alfred Reeves, of the independents, is no less sanguine regarding the outlook, his optimism being based on statistics gathered from authentic sources, and which cover the situation thoroughly.

"Possibly the most noteworthy feature is the increasing demand for moderate-priced cars on the part of physicians, contractors, salesman and others," said Mr. Reeves. "This field is in its infancy, as yet, and the opportunities developing are marvelous. Another line that is attracting attention is the taxicab. Wherever tried, these taxicabs have proved a success, and the favor with which they have been received has stimulated interest in their manufacture."

Reports from officers and the several committees were all of an encouraging nature. The treasurer's report showed last year to have been the most profitable in the history of the association. Equally gratifying was the statement of the show committee, last year's exhibit at the Grand Central Palace exceeding all previous efforts from a financial as well as artistic point of view, and permitting a 25 per cent. dividend to all exhibitors. Fifteen new members were added to the association during the year, making it the strongest numerically of any organization of its kind.

The sum of \$5,000, to be used according to their discretion during the coming year, was voted to the good roads committee, consisting of Charles E. Lewis, chairman; James Couzens, H. B. Krenning and R. E. Olds.

The association also voted, at the invitation of the American Automobile Association, to cooperate with that body in tours and races, the committee having the matter in charge consisting of H. O. Smith, chairman; Walter C. Marmon and A. C. Newby.

Officers of the association for the ensuing year, with the exception of Messrs. William Lewis, Everitt and Stoddard, all holdovers, are as follows:

Chairman of committee of management, Benjamin Briscoe, Maxwell-Briscoe Motor Co.; vice-chairman, R. E. Olds, Reo Motor Car Co.; treasurer, H. O. Smith, Premier Motor Manufacturing Co.; secretary, William Mitchell Lewis, Mitchell Motor Car Co.; auditor, W. H. VanDervoort, Moline Automobile Co.; additional directors, B. F. Everitt, Wayne Automobile Co.; Charles E. Lewis, Jackson Auto Co.; C. G. Stoddard, Dayton Motor Car Co.

## GOVERNOR AND MAYOR OPEN THE DETROIT SHOW

**D**ETROIT, Feb. 10.—Governor Fred M. Warner and staff and Mayor William B. Thompson lent dignity to the opening of the annual Tri-State Automobile and Sportsmen's show in Light Guard Armory to-night, both officials voicing a welcome to the State and city, and being given an enthusiastic reception by a crowd which occupied every available foot of space in the great auditorium.

This year's exhibition is in a sense a three-ring show, automobiles occupying the main floor, accessories being shown in the gallery, and motorcycles in the drill hall. Manager E. E. McMasters has labored long and arduously to make the event

a success, and has made good in every sense. There are some twenty exhibitors of motor cars, more than twice that numbers of models being shown, while several of the score of dealers have several makes on display. Accessories and motorcycles likewise have a larger representation than ever before. Special events have been planned for each evening during the week, Monday being Governor's night; Tuesday, Automobile Club night; Wednesday, Society night; Thursday, Good Roads night; Friday, Board of Commerce night; Saturday, Question Club night. The complete list of exhibitors is as follows:

### Main Floor.

Northern Motor Car Co.	Anderson Carriage Co.
Cadillac Motor Car Co.	Standard Auto Co. (Packard car).
Aerocar Motor Co.	Fee-Bock Auto Co. (Elmore and Waverly).
Welch Motor Car Co.	Motor Car Co.
Crescent Motor Car Co.	Wayne Auto Co.
Fee Electric Car Co.	Reliance Motor Car Co. (commercial cars).
Regal Auto Co.	Jackson Automobile Co., Jackson.
Oakland Motor Car Co., Pontiac.	
Rapid Motor Car Co., Pontiac.	
Brush Runabout Co.	
Bloomstorm Mfg. Co.	

### Gallery.

Ajax Grieb Rubber Co.	Chas. E. Miller, New York.
C. M. Preston.	Gemmer Manufacturing Co., Detroit.
Michigan Storage Battery Co.	Pittsburg Lamp & Brass Co.
Diamond Rubber Co.	Michelin Tire Co.
Desmond Speedometer Co.	

Wildenpin Tire Co.  
Morgan & Wright.  
Continental Caoutchouc.  
Jones Speedometer, New York.  
C. F. Splittdorf, New York.  
Goodyear Tire & Rubber Co.  
G & J Tire Co.  
Hartford Rubber Works Co.  
Heinze Coll Co., Lowell, Mass.  
Norris Auto Co., Saginaw.  
Hilbard Engineering Co., Detroit.  
Flisk Rubber Co.

B. F. Goodrich Co.  
N. Y. & N. J. Lubricant Co., New York.  
Perfection Non-Skid Climber Co.  
Witherbee Igniter Co.  
J. L. Gibney & Bro., Philadelphia, Pa.  
Auto Igniter Co., New York.  
Visor Knitting Co., Niagara Falls.  
Elastic Tire Filler Co., Boston.  
John H. Thompson & Co., Detroit.

### Drill Hall.

Economy Cycle Co.	W. E. Metzger.
Palm Engineering Co., Detroit.	Light Mfg. Co., Pottstown, Pa.
Seltz & Co., 225 Beecher avenue.	Excelsior Supply Co., Chicago.
F. Kicherer, 206 St. Aubin avenue.	Good Roads Exhibit.

## "FROM ATLANTA TO THE SEA."

By PATHFINDER



THE TYPE OF TOWN THE AUTOIST SEES IN GEORGIA.



HAND POWER COTTON PRESS THAT SEES SERVICE.



AN ACCIDENTAL MEETING WITH THE CHAIN GANG.



MANEUVERING THE WHITE STEAMER ON SAVANNAH WHARF.

GEORGIA has made so little progress in improving highways that, by no stretch of the imagination can that State be now considered as an attractive section for the automobilist. This is the verdict I have to render to my fellow tourists after my trip from Atlanta to Savannah, the fourth and last section of the tour of exploration I have been making in my White Steamer. In my article in last week's issue of *THE AUTOMOBILE*, I entered the complaint that the highways in certain sections of the South are adapted only for horse-drawn vehicles, but in some parts of the State of Georgia, the highways are not even adapted for horses and wagons, their condition being unsuited to any type of travel.

I do not wish to convey the impression that there are no good roads in Georgia. On the contrary, some of the counties have a fine stretch of almost perfect roads which have been built and are kept in repair by convict labor. The good-roads counties, however, are those in which the larger cities are located. In the majority of counties apparently no work whatever is done on the roads, for they are nothing more than sand trails. Sand does not make a good road, yet, on the other hand, it does not offer any particular difficulty to the tourist with a high-powered car. The principal reason why touring in Georgia is unattractive is that very few of the numerous streams are provided with bridges. Furthermore, as one approaches the coast, the country becomes more and more swampy, and it is hardly an exaggeration to say that one must do almost as much traveling in water as on the dry sand.

We reached Savannah under our own power, which is equivalent to saying that the water which we went through was in no place more than three feet deep, but it is certainly true that some of the streams which we forded were of this depth and the reason we could ford them was that we had enough steam in our generator to take us across, even when the water extinguished our burner. Also, although the water came up around the engine, the walls of the White engine are so well protected by asbestos that we did not run the risk of cracking a cylinder, as might easily have happened to cars whose cylinders would be directly exposed to the bath of cold water. It is evident, therefore, that this part of our tour was not of such a nature that many would care to follow us, particularly in the rainy months of January and February.

On leaving Atlanta, we had ten miles of fine road, which stopped abruptly at the county line, and from that point on we had a country road, which, although sandy, still had an admixture of clay which made a fairly good surface. We had no difficulty in finding our way, for all that day we paralleled the tracks of the Georgia Central Railroad. After we had traveled about thirty miles from Atlanta, the road consisted simply of a narrow trail between the railroad tracks on the one side and the cotton fields on the other. For much



THE BIGGEST OAK IN GEORGIA.

of the distance there is a road, such as I have just described, on either side of the railroad, and we crossed frequently from one side of the tracks to the other, according to which road seemed the better.

When the sand road terminated abruptly and a fine road began we knew that we were in the county where Macon is located. This part of our journey, from Atlanta to Macon, a distance of 103 miles, was the easiest kind of a day's ride, and I believe would be at any season of the year. There is not much water on this part of the route, and the sand is not particularly heavy.

As soon as we reached Macon, we perceived that the rest of our journey to Savannah would not be so easy. There are two garages at Macon, and at neither of them could we find any one who had ever made the trip to Savannah or who knew of any one who had made it. I called on the chief of construction of the Bell Telephone Company. "Don't follow the route our wires go," he said. "You will never get there if you do." Then I visited the offices of the Western Union Telegraph and the Postal Telegraph Companies, and each construction chief advised me not to follow *his* route. Our party held a council of war. "I cannot get any accurate road information," I said. "It looks as if we would have a hard time whichever way we go. Therefore, I move we follow the route which, as far as can be judged by observing on the map the courses of the different rivers, passes through the highest part of the State. It happens that such a route would be almost the shortest between the two cities." Motion unanimously carried, and without any more definite information than this, we started from Macon to Savannah.

We headed due east, having good roads as far as the county line, and thereafter very poor roads. We had spent the entire morning in search of road information in Macon, and, with the numerous stops to make inquiries along the road, we had not proceeded further than Jeffersonville when darkness came on, and here we spent the night. The hotel proprietor told us that we should proceed to Dublin, a little south of due east, and we would here find a bridge across the Oconee river. We made Dublin easily the next morning and here learned that a highway, known as the "Savannah road" starts at that place. Thereafter our task of finding the road was comparatively easy. All we needed to do was to ask for the "Savannah road" and we could obtain definite directions. Our only difficulty was that we several times took the wrong fork and traveled several miles before we would meet any one from whom we could make inquiries.

The country from Dublin to Savannah is of the same general character. All of it is swampy, and as one nears the

coast it becomes "more swampy." While cotton plantations are visible from time to time, the greater part of this section is given over to the turpentine industry, which means that most of the trees are dead or dying, and the country correspondingly desolate. As one approaches the coast the sand becomes heavier, and, since all the wagons drive in one track, the ruts are so deep that if your wheels once slip into them, there is no getting out until you reach a little stream or a pond of water in



CITY HALL AT SAVANNAH.



THE DESOLATE CHARACTER OF GEORGIA'S MAIN ROAD.



ONLY DEEPEST PARTS OF THE RIVERS ARE BRIDGED.



ALMOST AS MUCH WATER TRAVEL AS LAND TRAVEL.



BUILDING A TRESTLE OVER A PATCH OF QUICKSAND;



the roadway. We made a fairly comfortable run of about seventy-five miles that day and spent the night at Swainsboro at a hotel which, to put it politely, is probably suitable for the needs of its purely local trade.

From Swainsboro it was a case of heavier sand and deeper and more frequent fording places to Blythen. Here we saw before us, in the gathering shadows of the evening, the dreaded Ogeechee swamp, concerning which we had been hearing ever since leaving Dublin the most positive predictions that we could not cross it. We had again covered seventy-five miles for the day and were satisfied to wait until morning before attempting the passage. A day's travel of only seventy-five miles seems rather small unless one keeps in mind that, before going through the various fords, it is best to take time to sound them. My two companions had provided themselves with high rubber boots, and when we came to a stream or to a place where the water from a swamp encroached on the road, one of them would walk ahead and test its depth and find out if there were any soft places to be avoided.

After our night's stay at Blythen, we turned our attention to the Ogeechee swamp, which is formed by the Ogeechee river overflowing its banks. As my companions learned by wading ahead, there is a bridge over the deepest part of the stream, but in order to get to the bridge, and then from the bridge back to terra firma, they declared that we would have to go through not less than three feet of water.

Had we been starting on the tour from Savannah and then encountered the swamp, I would certainly have turned back, but having come so far and being almost within sight of our destination there was nothing to do but plunge into the water. And we came out safely on the other side, for reasons I indicated in one of the opening paragraphs. So momentous was the occasion of our passage of the swamp that we did not think about photographs until we had left it behind us, although we were "snapped" at some of the shallower fording places.

After passing the swamp we had about twelve miles more of sandy road, and then we struck an eleven-mile stretch of boulevard which led us into Savannah. With its broad avenues, handsome public buildings, splendid homes and, last but not least, the commodious Hotel De Soto, Savannah certainly looked good to us after almost three days spent in the turpentine country. We were promptly taken in charge by the enthusiastic local committee, which has the stock-car race in charge, and we were piloted over the sixteen-mile course, which is certainly well adapted for speeding. What impressed us the most, however, as regards the preparations

for the race, was the hearty co-operation which the State, city and county officials are lending to make the race a success. I could not help but express the hope that the problem of improving the roads in the interior counties of the State might, in the very near future, be attacked with the same enthusiasm and official assistance.

And now a few words in summary of our trip, an outline of which has been placed before the readers of THE AUTOMOBILE in four successive issues. Between New York and Savannah we covered a total of 2,044 miles; deducting side runs made to places of interest, etc., the distance between the two cities by the route which we followed is 1,830 miles. Our total elapsed time from New York to Savannah was three weeks and five days. Not all of this time was spent on the road, as we laid off one day in seven, and, moreover, took abundant time to see all places of interest on or near our route. As is evidenced by our uninterrupted progress, we had no trouble with the car. The total replacements comprised one front spring, in which a leaf was broken on the wretched roads leading to the Mammoth Cave. Before we could secure another spring we had traveled almost 400 miles, and I believe that, had we so desired, we could have finished the trip without even this one replacement. Aside from this matter of the spring, the only attention we gave to the car was to lubricate very thoroughly, to take up occasionally on our brakes and to tighten the stuffing boxes at intervals. The matter of tire repairs has been almost a negligible factor with us, partly owing to the fact that the White has tires of unusually large size and is, moreover, easy on tires, and partly because the Diamond tires on our machine showed themselves to be of good construction. One rear tire we did not touch; on the other we changed a casing. In one front tire we had a nail puncture, and on the other we renewed two inner tubes. I should also add that our Jones speedometer registered every turn of the wheel.

To review briefly the road conditions: From New York to Hagerstown is mostly over macadam; between Hagerstown and Cumberland the road is rough and neglected; from Cumberland to Springfield, Ohio, over the National highway, the objectionable features are the water-brakes; from Springfield to Cincinnati the roads are good; in Kentucky there are many miles of fine macadam, many miles of narrow twisting, well-surfaced roads, and some very bad stretches; in crossing Tennessee we found toll-roads most of the way; in Alabama there are many miles of pikes and many miles of mud; Georgia, the tenth and last State through which we passed, has only isolated communities where the good-roads idea has penetrated.

### HEARING ON THE A. A. A. FEDERAL BILL.

WASHINGTON, D. C., Feb. 10.—A hearing on the Cocks bill providing for Federal registration of automobiles will be granted automobilists by the subcommittee of the House Judiciary Committee having the bill in charge, probably February 27. A conference regarding the proposed legislation was held last week by Charles T. Terry, chairman of the Legislative Board of the A. A. A., and the real author of the Cocks measure; Secretary F. H. Elliott, of the same organization; Representative Cocks, who introduced the bill; President Yellott, of the Maryland Automobile Club; and President Caverly and Secretary Mark, of the Automobile Club of Washington. These men went over the situation very carefully, and among other things it was decided to induce as many club presidents as possible to be present at the hearing.

The sub-committee which has the Cocks bill in charge is composed of Representative Tirrell, chairman, and Representatives Caulfield and Brantly. Chairman Tirrell is an automobilist, and is believed to favor the proposed law.

### APPELLATE DIVISION SUSTAINS A. L. A. M.

In the action entitled Rowland vs. Clifton, familiarly known as the Searchmont suit, in which the trustees in bankruptcy of the defunct Searchmont Company attempted to enforce a division of the profits and assets of the Licensed Association on the ground that it was a partnership, the decision of Justice O'Gorman, dismissing the suit, which was rendered last spring, has just been unanimously affirmed by the Appellate Division of the Supreme Court. It was contended by the defense that the license of the Searchmont Company was forfeited when the latter went into bankruptcy, in accordance with the mutual agreement of the members when the association was formed, and Justice O'Gorman found that the provisions of the license in regard to its cancellation had been fully carried out, so that there was no ground for action. It was in 1904 that the Searchmont Automobile Company went into bankruptcy. In the earliest automobile contests, the Searchmont car made a very favorable showing, and a substantial future was predicted for the company.

## ANOTHER MATERIALIZATION OF THE IDEAL AUTO

By A. E. OSBORN.

HAVING been much interested in C. H. Godley's specifications of his "perfect" touring car, I thought that others might also be interested in such descriptions and would like to see something further in this line, so have prepared the accompanying description and drawing showing my idea of how such a vehicle should be made. It should be understood that the vehicle I am about to describe is only my preferred design for an automobile corresponding to Mr. Godley's and intended for the same character of service and not my idea of what is going to be the most popular and important form as this undoubtedly will be a vehicle selling below \$350. It is, in fact, a high class five-passenger car capable of meeting all ordinary requirements, although not, according to present standards, a high-priced one, as owing to its general design and to the simplification of many of its details (only a few of which can be mentioned within the limits of this article), it could be made in a first class manner and, I believe, profitably sold at from \$800 to \$1,200. This vehicle would preferably be fitted with an engine of from 12 to 20 horsepower, as a larger engine is only a useless extravagance ninety-nine per cent. of the time, and even in the remaining one per cent. of little service, as it only permits a higher speed (than is safe sometimes), and this is a matter that will be considered of little importance compared with maintenance, cost, fuel consumption, etc., in the future. Moreover, for reasons hereinafter explained, the power that the engine develops is, in this vehicle, transmitted in a more efficient way and applied in a more effective manner than has hitherto been the case, so that an engine of the power specified would give results more than equaling the results that could be obtained in other vehicles with from ten to twenty per cent. more power. I prefer that the engine have two offset cylinders, although it is realized that many prefer to sacrifice the simplicity, low cost and economy of the two-cylinder engine in order to gain a more even motion and I would provide for this preference by having my vehicle arranged so that a four-cylinder engine could be readily fitted and supplied at an extra price. The engine would be set with its shaft across the vehicle and would be air-cooled, as it is unmechanical and absurd to carry the water plumbing at present in fashion when better results can be gotten by the simpler, lighter and more direct air-cooling, if the air-cooling system is correctly designed. As I have some ideas in regard to two-cycle, air-cooled engines which I believe will make it superior to any other form, I naturally prefer its use on this vehicle and believe an engine of this type will supersede the ordinary four-cycle engine. However, even if a four-cycle engine was specified, it would not be of the present popular forms, but would have two 4 1-2-inch by 4 1-2-inch cylinders set at 45 degrees, a single-throw crankshaft, splash lubrication, detachable cylinder heads with valves in them, automatic intake valves, and special exhaust valve arrangements. The ignition should be by dry batteries, a single non-vibrator coil, with distributor and a special quick-acting contact timer, although provision should be made for fitting a magneto as an extra. The mixture

should be supplied by a carbureter, which should be automatic, without moving parts, be protected by screened inlets for gasoline and air, be arranged so that it can have its interior parts readily examined and be quickly detached from the vehicle, if necessary. It should have, as suggested by Mr. Godley, a special form of throttle valve whereby pure air can be admitted to the engine when desired, and I would prefer that this valve open the air port after it has cut off the mixture. The adjustments should comprise one thumb screw to regulate the mixture and one thumb screw to regulate the height of the fuel in the float chamber unless, as might sometimes be preferable, a pump feed to the carbureter were used when this latter adjustment could be eliminated. The muffler should be very simple, consisting mainly of a long piece of tubing with a special outlet. This completes the description of the important parts of the power plant of my perfect touring car, but it should be understood that in this description I have limited myself

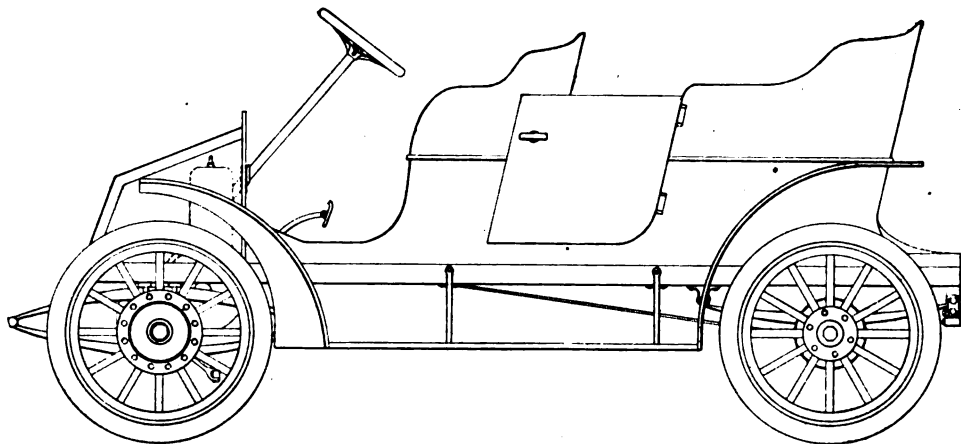

LINES AND PLACING OF THE POWER-PLANT OF THE PROPOSED IDEAL AUTO.

to constructions which will not necessitate any experimental work, and that, for this reason, no mention of the possible use of direct pump feed, hot surface or high-compression ignition and increased charge expansion (as suggested by another contributor to THE AUTOMOBILE, Mr. Lougheed) has been made, as these features have not as yet come into successful use on motor vehicles, though they may be used in the future ideal car.

We now come to a consideration of the most novel part of this vehicle, which is the method of transmitting the power from the engine to the wheels. The first of these transmitting elements is the charge-speed gear. This is a two-speed and reverse planetary with large cone clutch and of a patented form having not more than three gears and requiring only one brake band for its operation, thus doing away with one brake band and one band adjustment and set of band-tightening parts. It should not have any separate reverse gearing or idle revolving drums or gears, as these parts are the principal source of noise and loss of power in the ordinary planetary system. In fact, it is perfectly possible to obtain double the efficiency of the usual planetary gear and incidentally reduce its already low cost about one-half, and it is certain that when this fact is appreciated the planetary gear will supersede the present fashionable sliding gear. This gear should be connected to the differential by either a direct chain or by spur gears, so that the power loss, number of parts and weight would be reduced to an extent hitherto impossible when the power

is transmitted all along the vehicle and around corners. The reason why this very direct driving system is possible lies principally in the fact that, as has no doubt already been surmised from the drawing, my perfect car would be front driven and the entire driving mechanism would be in front of the dash. The connection between the differential and wheels is by a special system, for which a patent has been applied for and in which the universal joints necessary to allow for steering are subject to a very small amount of pressure. It is also designed so as to permit of wheel bearings of the usual size (they can be plain if desired) and to permit of pivoting the wheels in the center line of their tread, thus reducing the strains on the steering gear and its tendency to develop play, and making steering easier.

My ideal in brakes would be to have only one actuating pedal and arrange it to simultaneously operate shoes acting on all four wheels, so that the braking strains would be one-half that now acting on each rear wheel. Thus, not only could the car be stopped in a shorter distance and the expensive wear which arises through slipping the rear tires on the ground very greatly reduced, but skidding due to the application of the brakes to the rear wheels only is prevented. While on the subject of skidding I would say that this is, without question, to a great extent preventable by front driving, as the tendency which is always present in rear driven vehicles for the rear wheels to get in front is entirely absent. Moreover, as has been found in the case of a small "home made" front driven runabout that I have built, this type of vehicle will hold to its course better when crossing car tracks, etc., than if rear driven, and will not, in case of loss of traction from slippery roads, show any side slipping tendency. Another advantage of front driving is in the fact that the rear springs can be very flexible and are not interfered with by the power transmitting elements, and consequently solid rubber or even (for commercial work) steel tires can be used on the rear wheels. In fact, a vehicle of this type would permit the successful use of solid tires on all wheels, provided a slight sacrifice of speed was made. Still another advantage, and a most important one, lies in the fact that the complete power plant and steering gear with front wheels can be arranged so that it can be quickly

detached from the rest of the vehicle as a unit and thus not only would economy be gained in manufacturing, but one power plant could be used for different kinds of vehicles (such as the touring car, shown in the drawing, a light delivery wagon or a taxicab)—the changing of the front part to a new kind of rear equipment taking much less time than is required in hitching a horse. Moreover, the detachability of the power plant would permit of its ready examination and of carrying one reserve plant only for use in emergencies instead of a complete reserve vehicle, where a number of vehicles have to be kept in service.

The control of the vehicle is preferably by a rotary grip on the steering wheel or lever regulating both spark and throttle in a special manner and by a pedal giving the high speed, an interconnected pedal giving the low speed and reverse, and a pedal controlling the brakes and also, unless the high or low speeds are held in action by their pedals, operating to automatically release the engine.

It should be understood that in the accompanying drawing no attempt has been made to illustrate the exact body design or the arrangement of trimmings or attachments that would be used. The hood shown is very short, in order to give plenty of body room and bring the passengers between the wheels, thus making easier riding.

It is fully realized that the vehicle just described contains many novel features and that it is, no doubt, very presumptuous to believe that at least some of them will be in the future car in view of the fact that several prominent automobile engineers and manufacturers have given it as their opinion "that finality of design has been reached," "that the automobile of ten years hence will be substantially as it is to-day," "that only detail changes are possible," etc., etc.

In closing I would say that I would like to have any of your readers criticise the above specifications, as I think such discussion brings about a better understanding of the merits of any new designs that may be suggested and hastens the time when those who can assist in the development of the perfect car realize that perfection has not yet been attained and that there is some prospect of something differing from the present standards eventually coming into extensive use.

### HOW INDIANA'S AUTOS ARE DIVIDED.

INDIANAPOLIS, IND., Feb. 11.—The 5,000 mark in automobile registration was reached in Indiana the middle of last month. While there are in reality 5,143 motor registrations, 143 of these were for motorcycles, of which 43 are owned in the city of Indianapolis.

A comparative list which has just been prepared from the registrations in the Secretary of State's office discloses the fact that the seven makes having the most automobiles in use in Indiana are all manufactured outside of the State. This appears to be due to the fact that the average Indiana owner wants a low-power and medium-priced runabout, of which few are made in Indiana. Among the high-priced touring cars and runabouts Indiana manufacturers rank well. Registration figures show that there are 866 automobiles and 43 motorcycles in use in Indianapolis, Indiana manufacturers having the largest number. The twenty manufacturers leading in the number of automobiles in use in the State, as taken from the registers, are as follows:

Cadillac .....	515	Winton .....	110
Ford .....	494	White .....	100
Olds .....	415	Haynes .....	81
Rambler .....	249	National .....	79
Maxwell .....	214	Mitchell .....	77
Bulck .....	192	Franklin .....	77
Reo .....	168	Pope Toledo .....	74
Premier .....	159	Studebaker .....	72
Pope Waverly .....	134	Autocar .....	71
Auburn .....	117	Stoddard Dayton .....	62

### GLIDE MAKERS SEEKING EXPORT TRADE.

J. B. Bartholomew, president of the Bartholomew Company, Peoria, Ill., makers of the Glide cars, left on January 20 last for an extended tour through Mexico, during the course of which he will visit all the leading cities of the Spanish republic and will place several agencies. Attractively illustrated leaflets and catalogues with full specifications in Spanish have been prepared and a thorough canvass will be made in this branch of the foreign trade. This trip is in line with the well-known policy of the Bartholomew Company where export business is concerned, Mr. Bartholomew having made an extended trip through Brazil and Argentina in the early part of 1906. On the present trip he will remain in Mexico until about the first part of March.

### WHERE AUTOS ARE SCARCE.

Sonora, Cal., has "hopes" of some day becoming an automobile center. A query as to the prospects brought the following original response from the editor of the town's leading daily: "Most of the transportation here is per 14-mule team, driven by jerk line, or by Jerusalem jackass. Our subscribers who use automobiles are so limited in number that a census of the same would not leave more than a trace on the government blank. We are sorry, and hope some day matters will be different, and that, when our gold deposits are opened up more extensively, every one will have his own smoke wagon."—*Ex.*

## PLEASURES OF ROAD TESTING TOLD BY TESTER

By ARTHUR H. DENISON.

THE average autoist, in his delight at the new car, thinks little of what its mechanism underwent during its trying-out proceedings. In the glory of new upholstery, the brass work shining like gold, and the varnish glistening without mark or scratch, it presents an appearance totally different to that when its motor first opened its valves and the music of its exhaust was a song of its power and speed. There was a little paint on the frame, plenty of oil on the rest of the machinery. The tires had seen service on perhaps a dozen cars, and as for brass and mudguards, we cared little unless the exigencies of business demanded work night and day. Then we hunted searchlights with clean reflectors; mudguards were only a nuisance. If it was muddy, we didn't care. The friend who wanted a ride usually got it, and usually more than his fair share of mud and water.

I think one of the prettiest sights is to watch one of the front wheels from the seat, rolling onward, never halting or stopping except at the will of its guiding spirit. The chassis, its springs designed to carry from twelve to fifteen hundred pounds in tonneau, baggage and passengers, takes no notice of the small inequalities of the road, but will plunge in an alarming manner at the larger ones, such as water-breaks and raised crossings, when taken at speed. The weight of the testing body, a hundred and fifty pounds or so, the tester and his kit as ballast, seated over the center of mass on the car, has very little effect in making things ride easy.

The chassis before being turned over to the road tester has been run under its own power for about twelve hours, the power being delivered through the driving wheels to a pulley of the same diameter. From its shaft a belt ran to a larger fan, which utilized the power in forcing cool air through the radiator, sufficient to keep the engines cool. This running generally left the motors pretty free, but the effects of vibration were just commencing to be noticed. The front tires were then put on, brakes adjusted, and the tanks for the water, oil and gasoline supplies looked after. The testing body consisted of the front seats of an old touring body, fastened on to a suitable framework, giving a runabout effect, with plenty of storage room, and was held in place by four bolts and clamps, a firm yet quickly removable fastening.

We then took the car out for about an hour's run, staying close to the factory; and, easing the car as much as possible, then returned and looked things over carefully. The bouncing and jarring of the road soon brought out minor troubles. The clutch spring needed more tension, the carbureter needed adjusting, occasionally a little dirt getting in the spray nozzle, and it was "then dismount it and locate the obstruction." The muffler cut out wouldn't stay open, steering gear and driving chains were loose. There are very many little details that require attention after the car has had a little bouncing over rough roads, giving the frame a chance to work a little.

One of the worst, and possibly meanest forms of trouble, was a nut holding the magneto timing gear in place. This

was drawn up on a taper, and, as often was the case, the nut was not quite tight enough and allowed the gear to slip, throwing the magneto out of time. The lubrication, all pumps wide open, kept the engines smoking, and if the oil was in the least degree too heavy—the motor requiring the lightest oil obtainable—it would be impossible to start the motor when cold without taking the anvils out and removing a carbon deposit resembling black enamel.

After looking things over we usually gave the car a run of from 25 to 40 miles. Road troubles were very few, being chiefly confined to resetting the ignition. My tool kit was the usual roll carried by thousands of motorists, and spare parts and springs for the ignition system, a few special wrenches, and spare tires and tools in the back of the testing body. Each car was kept on the road for about 200 miles, then given a final test up a steep hill by the head tester before being turned in. We made out a report on a printed form that called for information on every part of the car that could give trouble and exactly how it acted under test.



TESTING A MATHESON NEAR THE WILKES-BARRE FACTORY.

The performance of the cars on the road test varied considerably, some giving little trouble, others on our hands for over a week. I recall one car coming off the block test marked perfect, and I took hold of it one evening. When ready to start it I found a cylinder full of water. This I emptied, started the motor, and drove the car that evening to see if there was much else to be done in it. The leakage of water was so small that it would not affect the operation of the car. This trouble

was remedied next morning. By that evening it had developed a bad case of noisy gears, due to the bevel gears used in timing the camshaft at the cylinder head not meshing at their pitch line. This necessitated dismounting the radiator and a half day's work to make things right. After that the clutch gave trouble, not releasing properly, and was taken out a couple of times before the trouble was located. Between these troubles, then bearings, and other details, that car was on my hands for a week and a half. The next one went through with no trouble.

When passed by the head tester, the tires and testing body removed, the chassis was washed and then turned over to the head inspector's staff. With the tester's report as a guide, they went over the car thoroughly, trying every nut and bolt, throwing the springs (which had shifted slightly) forward into place to receive the weight of the tonneau, and giving particular attention to steering connections. The rear wheels were raised on jacks, and the motor run under its own power to observe the action of the clutch, gear control and gears. Then the crankcase and clutch were cleaned and lubricated, the gear and differential cases also cleaned, inspected carefully and filled with grease. The chains received attention, brakes looked after and adjusted, after which the gear case and hood were wired and sealed closed, and the control lever wired to its quadrant, and the car was ready for the body builders.

I have seen around a car a group consisting of the mechanical and testing staffs and the head inspector about



equally divided in their opinions as to whether or not there was a "knock" in the motor. The controversy ending by orders being given to take the crankcase and bearings down and examine them. Nothing was too small to pass if there was the slightest reason to doubt its being right. Cars never reached the stage of road testing lacking some little part essential to their satisfactory performance.

There is a pleasure in testing that the owner never experi-

ences. The motor not hampered by the weight of tonneau and passengers, or air pressure on mudguards, has a great deal more snap and speed. To tune a car to its highest efficiency, to remember that upon the performance of that car may depend many sales, calls for a high degree of skill and intelligence on the part of the tester. A conscientious and ambitious student and tester of to-day should develop into a high-class designer in the next generation.

## FIGURES REVEALING AUTO'S GROWTH IN ALL COUNTRIES

A DECREASE of over one million dollars in American imports of automobiles is the most conspicuous feature of the world's statistics for the last financial year. To be exact, the United States took 102 less automobiles from abroad during the past twelve months than were bought in the year 1906, the reduction in value being \$1,358,880. Total imports from all countries for the past three years is as follows:

Year.	Cars.	Value.	Parts.
1905.....	490	\$1,866,402	\$136,057
1906.....	1,295	4,416,048	494,160
1907.....	1,093	3,157,168	650,408

France still remains at the head in number and value of cars sent to America, the total for 1907 being 835; Great Britain and Italy each have 91; Germany sent 53, and other countries together furnished 23.

Although America cut down her imports of foreign automobiles to a considerable extent, France managed to increase her exports by eight million francs, the total for 1907 being \$28,072,800, the largest amount ever recorded. England stands first in importance in French export trade, with a value of over \$10,000,000 for the past year, and is followed by Belgium, Germany and the United States. Argentina, Brazil and Algeria remain near the million dollar mark, all other countries being responsible for but small purchases. French imports show a decrease of one and a half million francs on the year. Italy heads the list, followed by Germany and Belgium.

### What America Sells to John Bull.

LONDON, Feb. 1.—Great Britain imported 542 American automobiles at a value of \$1,775 each during the year 1906, according to returns issued by the Board of Trade. For the year 1905 the number was 559 cars and the value \$1,185 each. In 1904 the number was 568, at an average value of \$1,090. Although for the three years for which returns are available there has been a slight progressive decrease in the number of American automobiles imported into England, their average value has steadily increased to such an extent that the total for each year is always higher than the total for the previous twelve months. In 1904 the total value was \$619,120; for 1905 it had risen to \$662,415; and for 1906 the total was \$962,050. The proportion of the number of American automobiles to the total imported was 10.56 per cent., 9.95 per cent., and 9.4 per cent. for the respective years, the value being 5.94 per cent., 5.43 per cent., and 9.95 per cent. of the total value of the automobiles imported. The value of the parts imported from America was relatively small, being 3.44 per cent., 1.44 per cent., and .88 per cent. for each of the three years. As motor cycles were included in the years prior to 1904, and all vehicles prior to 1902, it is not possible to give figures for years before 1904.

Another phase of the automobile invasion into British life is the greatly enhanced value of horseflesh. Farmers have taken fright and stopped breeding, and, in addition, the South African war has depleted the stock with the result that there are now 12,312 fewer horses in the United Kingdom than was the case twelve months ago. The most convincing proof of the rapid decline of horse-breeding is shown by the fact that

the great proportion of the British decrease is in young unbroken horses. Figures published by the Board of Agriculture show that there has been a decrease during the past year of 10,451, or 7.6 per cent. As regards Great Britain the number of such young horses is the lowest reached since 1900, while taking England alone the number is the lowest reached since records were begun to be kept in 1896. In many quarters the question of military supply is looked upon as serious.

### Reign of the Horse Ending in Paris.

PARIS, Feb. 1.—Foreign visitors to Paris will soon have no reason to pity the lot of the cab horse, and habitués of cheap restaurants will have to forego their luscious horse-steaks, if official figures count for anything. Every vehicle and every animal capable of drawing a vehicle is under obligation to the State for military service. Naturally a close watch is kept on all horses, and not a single "Dobbin" escapes the annual census. According to these returns, however, Paris now possesses but 83,458 horses compared with 92,026 in 1897, being a diminution of 8,568, or 10 per cent., in ten years.

The city has grown considerably in population during this decade, the decrease in horses being directly attributable to automobile traction. Not only have private individuals cut off the horse, but the cab companies have largely emptied their stables. The only omnibus company of the city shows a decrease of 3,972 horses owing to the introduction of automobile 'buses. At least 500 more should be added to this number, for early in January the company changed several lines from horse to mechanical traction. In time of war all omnibus horses can be requisitioned for work in artillery regiments; thus the loss of those from the Paris company alone means that several regiments would be without their full force. Such a change cannot but compel the army authorities to further develop the automobile service in all sections of the national fighting force. Recent events, indeed, have shown that the army no longer considers it prudent to rely on the horses obtainable by requisition in time of war, and are making strong efforts to develop the army automobile service to such a pitch that mechanical transport can be used entirely in transport work and to a limited extent in the artillery service.

Despite the enormous influx of taxicabs, the largest cab company in Paris has only diminished its horse force by 1,878 in ten years. In taking note of the figures, however, it should be borne in mind that the total number of vehicles has increased considerably during the decade. The greatest changes have taken place in the aristocratic residential quarters. Thus in the Champs Elysées district there were 4,473 horses ten years ago; the last census reveals but 2,878, or a reduction of one-third. The adjoining Monceau district shows a reduction of 1,318 horses used for pleasure during the same period. Latest statistics give the number of horse vehicles in the whole of France as 1,677,362, of which 226,600 are pleasure vehicles. As the number of automobiles is only 31,000, there is still plenty of room for activity on the part of the constructor.

## LETTERS INTERESTING AND INSTRUCTIVE

### LIMITING SPEED CAPABILITY OF CARS.

Editor THE AUTOMOBILE:

[1,153.]—This letter is sent to you to see if an automobile magazine is willing to open its columns to the discussion of an original plan, whereby the reckless disregard of automobile drivers for other road users' rights can be completely and effectively prevented. I propose that the different State and local authorities make it unlawful for any one to build, sell, or use automobiles capable of exceeding the maximum legal limit. I would like to have it explained to me why this would not be perfectly satisfactory to all law-abiding automobile users, while at the same time constituting a bar to the abuse of the roads.

M. A. TONKIN.

Louisville, Ky.

There are a number of most glaring defects in the scheme you propose, as a very little explanation will make clear. Moreover, the idea is not at all new, having been often suggested in this country and abroad, and having been as invariably given up by legislators and by its proponents, not only because of objections from automobile users, but also because of its proved inadequacy to bring about the results intended to be accomplished. In the first place, only the maximum speed limit is taken into account, with the result that any car capable of nearly reaching this is capable of greatly exceeding the lower speeds that are statutory for city streets, approaching corners and bridges, etc., and the enforcement of which is much more important than the enforcement of the speed limit on little-used country roads. Another difficulty that it would be hard to avoid would concern the question of speed down hill. For example, a car with a motor and gear ratios, making it impossible to exceed a certain speed under ordinary conditions, would nevertheless be capable of simply coasting at a highly dangerous speed under the most dangerous of all circumstances—on a long down grade. A final and conclusive flaw in your plan is the mechanical difficulty of arranging a car to conform to it. Any automobile with power enough to climb hills and to make fair speed over muddy or sandy roads must have power enough to go much faster than is ordinarily desired on good stretches of hard road and on slight down grades.

### BETTER TO REBORE BOTH CYLINDERS.

Editor THE AUTOMOBILE:

[1,154.]—I have a two-cylinder opposed motor in my car. One cylinder is cut by reason of the pin through the piston having slipped. Would it be advisable to have that cylinder re-bored? The groove is probably 1-8 inch deep, which would necessitate 1-4 inch enlargement. In case I have same done could I expect good results, and should I have new piston or simply new and larger rings?

C. G. MOORE.

Sharon, Ia.

Where such a deep cut as this must be taken from the cylinder wall, though the cut would probably not have to be as great as you say, it is hardly advisable to have but one cylinder rebored, as a new piston would have to be fitted, and it would be found difficult to properly balance the engine, either mechanically or otherwise, in its altered condition. Unless the price of a new cylinder to replace the one damaged is prohibitive, or a new cylinder cannot be obtained, we should not advise this course, as reboring one cylinder would necessitate a similar operation to the other, as well as the supplying of new pistons for both, and these being of a special size, would doubtless have to be made to order, thus entailing considerable expense. It is further questionable whether the cylinder in question will stand reboring, or, if it has sufficient wall metal to do so, whether it will be of any value after this has been done. In case of reboring, both new pistons and new rings would be necessary.

### RECHARGING A HIGH VOLTAGE BATTERY.

Editor THE AUTOMOBILE:

[1,155.]—Will you kindly answer this question through your "Letters Interesting and Instructive": I have a "Vestal" storage battery which requires 115 volts and 3 amperes for 20 hours to recharge. Would it be possible to charge it with a small dynamo having an output of 10 volts and 3 amperes if left connected for 240 hours, or 12 times as long, or can it only be done by having the voltages stated on the cell—115?

B. HARRY SMUCKER.

Belleville, Pa.

The number 115 is not the voltage of the cell, and as we presume it is employed for ignition purposes, this will not exceed six or eight volts. It is not the voltage that charges the battery, but the amount of current set through it, but if the voltage of the supply be not greater than that of the battery being charged, the latter will rise to a point where it overcomes that of the supply, and, in the case of a generator, is apt to reverse the polarity, or direction of the current, and then discharge itself through the outlet thus made. If the charging rate of your battery is three amperes the voltage of the current will not affect the time required so long as it exceeds that of the battery itself, so that if your battery does not exceed eight volts you can charge it with a current of three amperes generated by a 10-volt dynamo in the same time as with the 115-volt current. Where the difference in voltage is so small the cells should be watched to guard against reversing as the charge approaches completion.

### COVERING BRIGHT BRASS WITH VARNISH.

Editor THE AUTOMOBILE:

[1,156.]—Can the brass on radiators, dash rails, acetylene, and oil lamps be painted with ordinary paint and varnish such as bodies are finished with? Must brass be previously prepared in order to make paint stand successfully? Is heat of lamps sufficient to damage paint on their exterior?

J. A. C. K.

Newburgh, N. Y.

We have never known carriage varnish to be applied to brass and doubt whether it would make a good job, if it be desired to retain its brightness. However, it may be painted with any ordinary varnish or paint, and the latter will adhere permanently if the brass be thoroughly cleaned previous to its application. The best method of doing this is to rub the parts in question with a weak acid solution, vinegar and salt, or dilute sulphuric acid and water being employed, and every particle of foreign matter being removed. This is then followed with a liberal application of warm water, or soap and water, to remove every trace of the acid, the brass finally being polished dry with a clean cloth. It is then ready to be painted. In finishing brass to retain its polish a similar cleaning process is gone through, and it is then covered with a transparent lacquer especially made for the purpose.

### DOUBLING THE PROPELLER SPEED.

Editor THE AUTOMOBILE:

[1,157.]—Will you kindly advise me as to your knowledge regarding motor boats? For instance, we have a 30-foot boat with a three-cylinder two-cycle Barber Bros. engine, which runs about 500 r.p.m. Could this engine be made to turn the propeller, which is 18 inches, twice as fast as it is now turning? By putting two sprocket wheels, geared 2 to 1, running by a chain on the main shaft behind the clutch? If so, do you think this would be advisable and would it work satisfactorily? Also do you think it would put twice the strain or twice the power which it now takes to turn it after the boat is under full headway, not counting the excess power it now has? I understand that it would take twice the power to start it, after it was in motion; would it? The bore of the cylinder is 4 1-4 by 4 1-2.

C. H. B.

Bradford, Pa.

We think such an alteration as you propose to be impracticable for a number of reasons. You do not give the pitch

or other details of the propeller, and without these it is impossible to say whether such a propeller as is now fitted to your boat could be run at a speed of 1,000 r. p. m. without causing cavitation, *i. e.*, creating a vacuum in its plane of revolution instead of impelling the water from it and thus forcing the boat ahead. The chances are that it could not be so run, and that instead of gaining speed you would lose it while the engine raced to a greater or less extent. Granting, however, that this disadvantage were not encountered, it is doubtful if the motor has the capacity to carry considerably more than 100 per cent. overload, as it has doubtless been fitted with a propeller suited to its power, and doubling the speed of the propeller does far more than double the amount of power required to turn it, owing to the greatly increased resistance at higher speeds.

Nor do we think that the plan of running the propeller by sprockets and chain a good one and would not advise it, as we do not think it would prove satisfactory in service. As already mentioned, it would take more than double the power now required to run this propeller at twice the speed, whether starting or with the boat under full headway, granted that it would be able to attain its normal speed in view of the slippage of the propeller that is apt to occur. If it be desired to increase the speed of the boat to the maximum, we should advise fitting a larger propeller, or one having a greater number of blades, or of a different pitch, or both. The best authority to apply to for information on this point would be the maker of the boat, as he would know just what it and its power-plant are capable of and could advise accordingly. Such an experiment as you contemplate, however, would scarcely prove satisfactory.

### A MODERN FABLE OF THE CYLINDERS.

Editor THE AUTOMOBILE:

[1,158.]—I have been very much interested in the 1-2-4-6 cylinder controversy. Have read with pleasure the comparisons made by the different gentlemen of different opinions. The four-legged horse, the two-legged ostrich, and the comparative wheel base (from our Los Angeles friend), but as yet no one seems to have settled the matter satisfactorily. If it is not asking too much of your valuable time, I would like to have you read the following little story and before reading please remember that there are a lot of things between the lines, not mentioned:

Once upon a time, it happened that a man got a job carrying mail from a railroad station on one of our western roads to a country four corners, situated about 20 miles from the railroad, in a very productive locality. So he bought himself a single-cylinder mule and a two-wheel cart. His trip was a tri-weekly affair and he experienced no trouble making his route on time, in fact, near this four corners was a lake, well stocked with bass and pickerel. The job was so easy that he had plenty of time to catch a mess of fish for himself and many times for his friends.

As the country grew in numbers, there was now and then a man who would want a ride to the station, but on account of his two-wheeled cart and one-cylinder mule, it was not very satisfactory to his patrons to be bumped and jerked for twenty miles over roads that were none too good, so he bought another single-cylinder mule and a two-seated buckboard. His patrons liked the improvement in transportation so well that his business increased so fast he was unable to carry all his passengers. He, however, continued to fish in the nearby lake, but not so often as when he drove the one single-cylinder mule.

Being a progressive man, he couldn't help seeing that if he wanted to do business and please the patrons on his route he was due to do something, so he bought two more single-cylinder mules and a four-in-hand coach. He also built a manifold manger and fed the mules singly one at a time, all from one oat bin. He used the make and brake, except when he got in a hurry, then he used the jump to better advantage.

Business increased, but owing to his extra work on the four single-cylinder mules and keeping the four-in-hand coach greased he found little time to fish, but that did not worry him as with his increase in revenue he could hire a boy to catch his fish. The only thing he lost was the fun of spitting on his bait and seeing the fish flop when he pulled them in.

But the country kept growing and consequently he had more people piling into his coach and the loads got so heavy for his four single-cylinder mules that every week or two he would come in with a missing mule. This caused a kick from the patrons, as they did not like being late to dinner and they blowed so hard it set our

mule-chauffeur working his thinking machinery. Something had to be done.

The work was certainly too strenuous for the four single-cylinder mules, yet his four-in-hand coach was capable of carrying more passengers and finally he figured out that it would not be amiss to buy two more single-cylinder mules, which he did and there was great talk throughout the country around. He lowered his running time to such an extent that his patrons asked him why in the dickens he hadn't done it before. There was such an improvement in the movement of the coach that his passengers would fall asleep and the consequence was that he had to strap them in or else stop and pick them up when they dropped out.

One fine day, his old friend Bill made up his mind that he would ride into the city, so he climbed to the driver's seat, so he could have a good view of the scenery and incidentally a little visit with our worthy mule driver. They were just passing the lake near the four corners and Bill saw his old friend's longing glances out over the lake and Bill said, "Say, old man, how is it I never see you fishing any more?" "Fish?" says Bill, "I'd awfully like to pull in a few, but I'd like to see a man buckle the croopers under six mules' tails, water and feed and clean and attend to keeping them all shod, besides keeping this blamed four-in-hand coach oiled and cleaned and look after the welfare of all these passengers and then find time to fish. Do you know, Bill, I often long for the good old days when I drove the one single-cylinder mule."

Cadillac, Mich.

C. E. HAYNES.

### FROM THE STANDPOINT OF THE CHAUFFEUR.

Editor THE AUTOMOBILE:

[1,159.]—I see by your last edition that you have a piece about the chauffeur who was inexperienced and about a "prospect" who was getting a demonstration and met with an accident on Michigan avenue. Now I am going to mail you one of our applications, and you can see for yourself what we are trying to do. We also have an examining board, and they must pass 75 or better or they are rejected for three months, and he must also drive a car for one year or more before he can get an application. I don't think anyone is to blame if an owner wants to hire a man who does not know what an automobile is or does not know what is under the hood; all he knows is to drive it. Now, you take nine-tenths of the cars that are on the market to-day and they are bound to run, and run right, if the man that is on the position knows how to take care of the motor and not waste his time in playing cards and going to the saloon next door.

There are drivers in Chicago that the minute they hear something going wrong, they stop right then and there and fix it. At the same time there are others who would say to their employer (who has also noticed that something is wrong): "Let it go; I will fix it when I get home." Now, if he lets it go, it might run into something more serious, and what he could have done in five minutes on the road will now take him two or three days to do, and at an expense of maybe \$200 to his employer. And another thing we are trying to do, and that is to do away with the man that poses as the owner of the car, or as you all know, the railroader. We have what you call a judiciary board, and they will deal with those drivers as they should be dealt with. We want the support of all the owners and dealers in Chicago if we can get it, and in return we will show them the chauffeur is not so black as painted.

Now, I know where there was a man put on a new car who had never driven a car before, only at one of those motor schools, and in four months he was discharged and the car had to go into the shop and be overhauled at the expense of \$250; and there was another man put on the car like the first one, just to save \$5 a week. In another three months the car will have to have another overhauling, at another expense of \$250. I have looked up these two drivers, and I can truthfully say that both of them got their knowledge out of one of the motor schools here in Chicago. The first man I speak of was recently put on a new car just from the factory, and a more difficult one than the first one, and I suppose that one will be ready for the shop in about three months. I rode downtown the other day in that same car, and I watched the sight feed (oil) on the dash, and I saw that it was not feeding enough oil and I mentioned it to the driver and he said: "To h— with it; I am not going to bother making another adjustment on it."

There are owners in the city who have gotten in conversation with some other owner, and he will tell the other owner that he gets his driver for \$75 a month and his man leaves him, and then No. 1 tries to get a man for \$75, and succeeds in getting one like I told you about. While, on the other hand, his first man always had his car in A-1 shape and was always ready when he was called.

I wish you would call that writer's attention—Fred L. Morgan—that just such a move has been started, and we mean to keep it up. Our examining board is of five drivers who have been in the game for at least five years, and I can truthfully say that there are three of them who drove cars here in 1900.

I think if we can show every one connected with the game that there are good chauffeurs in Chicago they will try and help us get

a bill passed at Springfield to make all drivers stand an examination of some kind before they can get a license, and then you will find that nearly all of the accidents will stop. It was shown for itself that nine times out of ten that where an accident occurred that the driver was a new one, and did not know his business.

Now, I hope you will give this your attention, and a little of our association in your paper once in awhile will do us a world of good. And please mention that we are going to give a smoker to the dealers here in Chicago, and lay our plans before them and see if they won't help us and give us their support. And when we get that, we will go ahead and clean Chicago of the poor chauffeurs.

We have got a sick benefit from which we pay \$6 a week to a single man and \$10 to a married man who is sick from other causes than liquor.

Chicago, Ill.

EMMETT H. WALLER.

### IN EXPLANATION OF THE MYSTERY.

Editor THE AUTOMOBILE:

[1.160.]—In reply to No. 1,141 of "Letters Interesting and Instructive" will say if the cause is not in the lack of proper circulation or in the wiring, it must be a growth of carbon reaching one point of the plug. This in connection with a certain wiring will ruin as many plugs as inserted, or in the wiring exclusively. If you had stated what was used and how (dry cells, coil, or generator) could have given a clearer idea.

Darlington, Md.

SELFE & WHITEFORD.

Editor THE AUTOMOBILE:

[1.161.]—In reply to your reference of two-cycle, No. 1,141, in "Letters Interesting and Instructive," would say that providing that his spark plug screws in tightly and does not leak, there can be only two things possible, that I can see, and that is pre-ignition, or else his exhaust pipe or muffler is very nearly stopped up with a formation of salts caused by carbon and salt water, generally found in an elbow. I have seen the same thing puzzle at least four experts from two different factories; two from the factory where the engine was made, although this was a four-cycle. They took the carbureter off, and blamed that, put on a new one, and this did not help any at all, so they put on a new magneto and still it was the same story; then they told the owner that he would have to get a new engine; apparently at the end of their rope; after working for two weeks. This the owner refused to do, as he had only used the boat two seasons and had taken the best of care of the engine, it showing no perceptible wear anywhere, and he would not spend the price of a new engine to find out the trouble. He asked me to spend a day on it, as a day more or less would not make any difference, so I did. I found the compression good, ignition and timing nearly perfect. Then I started up the engine, which she readily did, but upon taking about 12 or 14 explosions on both cylinders, she started to miss on the rear cylinder, and no matter how I tried she would not fire it unless I stopped and started her over again, when she would repeat the same performance. Then I took off the exhaust pipes and instantly the engine fired both cylinders, which conclusively proved excessive back pressure, and upon disconnecting the exhaust, found one of the elbows completely stopped up with carbon salts, having only an opening as big around as a lead pencil, to exhaust through, which was very hard to clean out, having to use hammer and chisel, and on being put back the engine ran as good as when she was new. I then put back the condemned carbureter and magneto, and it did not make a particle of difference, the engine running just as good.

Hicksville, L. I.

FRANK SCHWARZENBERGER.

Editor THE AUTOMOBILE:

[1.162.]—I have noticed inquiry No. 1,141 in your January 30 issue, and if suggestions based on fifteen years' experience as gas engine ignition expert are acceptable to "Two Cycle," I am pleased to offer them. I am sorry we are not informed whether the two-cylinder two-cycle 11-horsepower motor is supplied by a single carbureter, or by separate ones for each cylinder, but will assume first that the former condition exists. In this case it is probable that the inlet valve in the rear cylinder opens more freely or wider than the one in the forward cylinder, so that a larger amount of mixture enters base and results in higher compression with consequent higher temperature in the cylinder. Attempts to regulate mixture results in this cylinder getting a so-called "lean" mixture, which maintains its heating power through a wider distance than does richer mixtures. This difference being due to the fact that forward cylinder suction cleans out the carbureter without pulling fuel enough for the next suction which, of course, goes to the rear cylinder, leaving a rich deposit in passage for the next forward suction.

If separate carbureters are used, the difficulty will be reduced by feeding a little extra fuel to rear cylinder.

Other prolific causes of such difficulties are: a partially clogged exhaust in either cylinder; a partially clogged inlet-port in other cylinder, or possibly a variation in head castings, whereby the rear plug might extend farther into the combustion space. The spark

points should extend slightly past inner wall under ordinary conditions, but if the plugs have an air space of liberal size, and points heat up, the plugs might be shorter, but not so much as to cause miss-fires. I have assumed that ignition current and timer are working perfectly, so that miss-fires are not occurring in forward cylinder and keeping temperatures and speed down.

These ideas may be sufficient, but if "Two-Cycle" cares to write further particulars, the writer will take pleasure in giving the matter further attention.

F. J. WATT.

New York City.

### A LAYMAN'S VIEW OF THE MATTER.

Editor THE AUTOMOBILE:

[1.163.]—I have read with considerable interest the long drawn out controversy taking place in your columns between the exponents of the fours and sixes, and which is very interesting from a theoretical viewpoint. But it seems to me, being a layman, that there is something now due the public-laymen—on the practical side of the question. It seems like a ridiculous and ludicrous position in which are placed so-called mechanical engineers and automobile experts—men whose mechanical training should have pre-determined, without asking the public to bear the experimental expense, the proper solution of the problem. The writer is fully cognizant of the fact that it is only through the friction of ideas that true progress is made. But why impose the expense of this experimenting on gullible people?

But from the glaring imperfections that have obtained in the automobile business up to the present time, it is very patent that the engineers know very little more, if any, than their customers about what should be embodied in a machine. The old maxim, "Be sure you are right, then go ahead," should apply especially to the automobile industry, and cars should be thoroughly tested out and sold on their merits, and not on promises and claims which fail to be fulfilled by the car.

We have a condition in the trade to-day which presents two radically different opinions. Some manufacturers claim fours as the standard and acme of perfection as regards number of cylinders of the four-cycle type. Others maintain all the virtues of the sixes. There is a way of proving this. The A. C. A., in its New York clubrooms, has just installed what is perhaps the most complete experimental equipment on automobile work in this country. I am now going to suggest a sane, reasonable and equitable proposition, and one to which I believe any honest, sincere, and well-meaning manufacturer could take no exception; but one in which I do not believe any two makers will concur, for obvious reasons, viz.:

Let each exponent of his favorite model—the two foremost exponents of the four and six, respectively, submit a stock car of their own selection to an impartial committee of the A. C. A. testing and experimenting. Give this committee full power to test the cars in whatever manner they choose for the different points of efficiency in which they claim to excel, always, of course, submitting both cars to the same test. Give the results of tests on all points in which the public or engineers are interested. Wear the cars out, if need be! It will be disastrous for the loser; therefore, I despair of the contest, but these are matters on which buyers should be informed, so let the fittest survive without needless expense to the public.

Whether automobile manufacturers admit it or not, the handwriting on the wall proclaims that the high-priced automobile market is limited, and that from this time on many manufacturers must look to the so-called middle class for their patronage. This class of buyers have no leisure money. They are the ones who sign checks for value received, and must "be shown."

Why not cease all this useless and senseless bickering and quibbling and get down to facts, which can easily be obtained by practical work and tests? The publicity managers have had their inning at the expense of the rich and affluent. Now let the practicability have a chance. Money talks! So do figures! Give these a word and some of the publicity managers can be dispensed with.

The writer would like to have "The Automobile" secure statements on this proposition, and publish their replies in its columns. It should be interesting reading, and would be a service for which more of your readers than the writer would thank you.

Detroit, Mich.

AN INTERESTED READER.

### FOR CALCULATING COMPRESSION VOLUMES.

Editor THE AUTOMOBILE:

[1.164.]—As a subscriber to your publication, I would like to make a correction to No. 1,120 of your "Letters Interesting and Instructive." If you will go over your calculation you will find your arithmetic has gone amiss. Also you have used the wrong formula.  $P_1 V_1^n = P_2 V_2^n$  or  $P V^n = K$  a constant, are two forms of formula used for calculating compression space in which  $P =$  pressure,  $V =$  volume, and  $n$  is an exponent of  $V$ , whose value depends on the gas being used.

Using your own symbols. Let  $V =$  volume swept out by piston or piston displacement, and  $C =$  compression space. Then  $V + C =$



total volume gas in cylinder at completion of suction and this is compressed into space C.

Now Mr. Allen wants 75 pounds compression, and I assume that he means gauge pressure, as that is nearer common practice for automobiles. Then the absolute pressure would be 75 + 14.7 = 89.7 pounds or say 90 pounds in round numbers.

Now applying the formula,  $P_1 = 14.7$  and  $V_1 = V + C$ ,  $P_2 = 90$  and  $V_2 = C$ , so that substituting we have  $14.7 (V + C)^n = 90 C^n$ .

$$\text{or } \frac{(V + C)^n}{C^n} = \frac{90}{14.7} = 6.122.$$

Now for a value for the exponent n, 1.3 is about what is used for gasoline vapor mixed with air. Then our formula reads:

$$\frac{(V + C)^{1.3}}{C} = 6.122 \text{ or } \frac{V + C}{C} = (6.122)^{\frac{1}{1.3}}$$

$$\text{Log. of } 6.122 = .7869$$

$$\text{“ “ } (6.122)^{\frac{1}{1.3}} = \frac{.7869}{1.3} = .6053$$

$$\text{Then } (6.122)^{\frac{1}{1.3}} = 4.03$$

$$\text{Then } \frac{V + C}{C} = 4.03 \text{ or } V + C = 4.03 C$$

$$\text{or } V = 3.03 C$$

$$\text{or } \frac{V}{3.03} = C$$

$$\text{or } C = .33 V = 33 \text{ per cent. of piston displacement.}$$

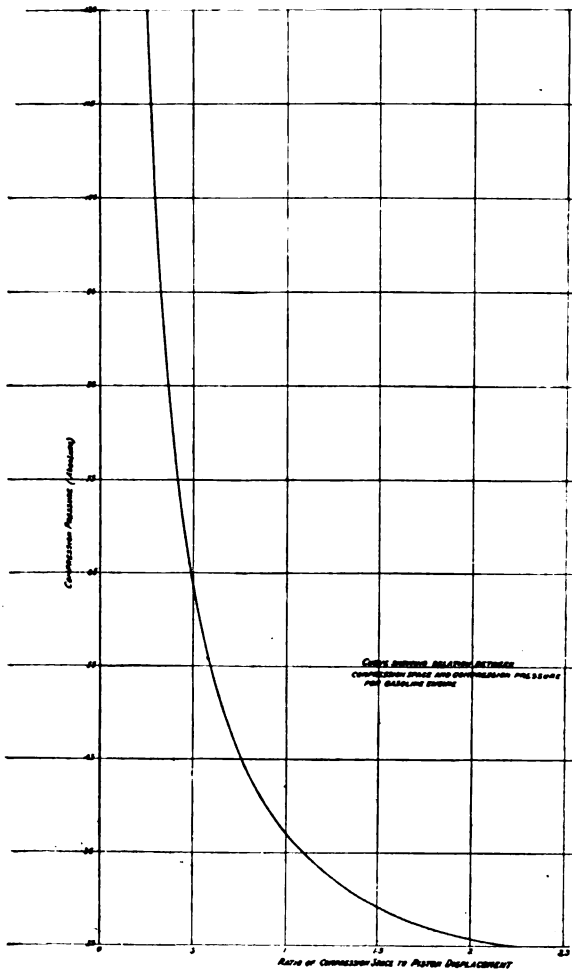

RATIO OF COMPRESSION SPACE TO DISPLACEMENT.

From this, by substituting values for D and L in the formula  $V = \text{piston displacement} = .7854 D^2 \times L$ , in which D = diameter of bore in inches and L = stroke in inches, the compression space for any diameter and stroke can be found.

I am enclosing blue print of curve showing relation between compression space and compression pressure in gasoline engine. This curve was plotted by formula given above for every five pounds between 25 degrees and 125 degrees, thus giving complete data over a wide range, and facilitating the finding of this factor without extensive calculations.

You will see that the ratio of compression space to piston displacement opposite 90 pounds absolute compression pressure is .345 or 24.5 per cent. of piston displacement. The discrepancy occurs in using 1.33 for value of exponent n.

Flint, Mich.

PERCY F. TODD.

### ABOUT BRAKING WITH THE MOTOR.

Editor THE AUTOMOBILE:

[1,165.]—Referring to Elmer Willard's question in the January 30 issue, regarding the use of the engine as a brake, I would mention that the Safir Motor Company, in Zurich, Switzerland, takes advantage of this by means of a special appliance. The carburetor is controlled by a lever on the steering wheel. This same lever on the steering wheel when rotated in the opposite direction has the function of shutting off the gasoline supply from the carburetor, opening the carburetor air passage and changing the timing of the exhaust valves of the motor with reference to the crankshaft position, thereby transforming the motor temporarily into an air compressor. In order to secure the maximum braking power, which is 75 per cent. of the motor power, the exhaust valves are opened by means of a shifting cam at a period when, under the normal operating condition of the motor, the explosion stroke would commence and the operating cycle would follow, thus:

1. Admission of air through inlet valves.
2. Compression of air with valves closed.
3. Opening of exhaust valves at top dead center and exhaust of compressed air. Re-aspiration through exhaust pipe under atmospheric pressure.
4. Compression of air with valves closed and opening of inlet valve on top dead center and release of compressed air, followed by the same series of air admission, compression and exhaust.

By gradually altering the timing of the exhaust the braking power can be varied at will from zero to the maximum.

The advantages of this form of braking are self-evident, the principal being the extreme flexibility of control, cooling and cleaning the motor with fresh air, elimination of heat and wear always present in friction brakes, and reduced tendency toward skidding.

In Switzerland I have driven one of these trucks, with full load, down a 10 per cent. slope on second without any other brake.

Chicago Ill.

FRANGOTT HUBSCHER.

### IT WAS 387.09 MILES FOR A GALLON OF OIL.

Editor THE AUTOMOBILE:

[1,166.]—On returning from a month's visit in Washington, I looked through the numbers of "The Automobile" that had come during my absence, and saw in your issue of January 16 a letter signed "Munchhausen," in which the writer thereof questions the accuracy of my statement to the effect that I averaged 387.09 miles to a gallon of cylinder oil. In reply to his letter I would say: (1) That before sending to you that expense account of my car I went over all the figures twice and found them to be correct. (2) I have been over them again, and have again found them to be correct, having again referred to my two books. (3) I have a Veeder odometer on my car, which enables me to know exactly the distance traveled. (4) In the two books that I keep I always enter the time of putting oil into the crankcase and the exact amount poured in, and also the total amount of oil purchased. The two books thus form a check the one upon the other.

I note that Munchhausen says that he is running a car similar to mine in all respects but one—his being a runabout and mine a touring car—and that when he averages 100 miles to the gallon he thinks he is doing well. That leads me to believe that his car is not of the same make as mine, because to the best of my knowledge and belief the firm that makes my car has never in all its history turned out an air-cooled runabout. This year they are making a 40-horsepower water-cooled roadster besides.

If Munchhausen thinks that my oil figures are still "so obviously an error" and desires further light, I can give him the names and addresses of three people in my town whose experience as to oil consumption and freedom from trouble and repairs has been practically the same as mine. They are using the same make of car.

East Orange, N. J.

J. G. C.

### A KICK FROM THE RETAIL DEALER.

Editor THE AUTOMOBILE:

[1,167.]—I think the manufacturers of automobiles have a "big kick" coming from the legitimate dealers, and particularly those who have signed contracts for a certain number of cars for the season. It is the custom of most manufacturers to arrange with any person, "Tom, Dick and Harry," without regard to what business he follows, to represent them in a given territory, provided he will order from one to three or four cars. The result is he will get two or three of his friends or persons to form a club and they will each get their cars at wholesale price and the dealer is left out, as he must sell his cars at a profit to live; in fact, he must agree not to sell below the list price, under penalty of losing the agency. But what does the doctor or lawyer care so long as he gets his car at wholesale price?

Is it not about time that the manufacturer recognized the regular legitimate dealer, and not establish agencies with persons who are not in the business?

Watertown, N. Y.

AUTOMOBILE DEALER.



BROADWAY ENTRANCE TO BUILDING.

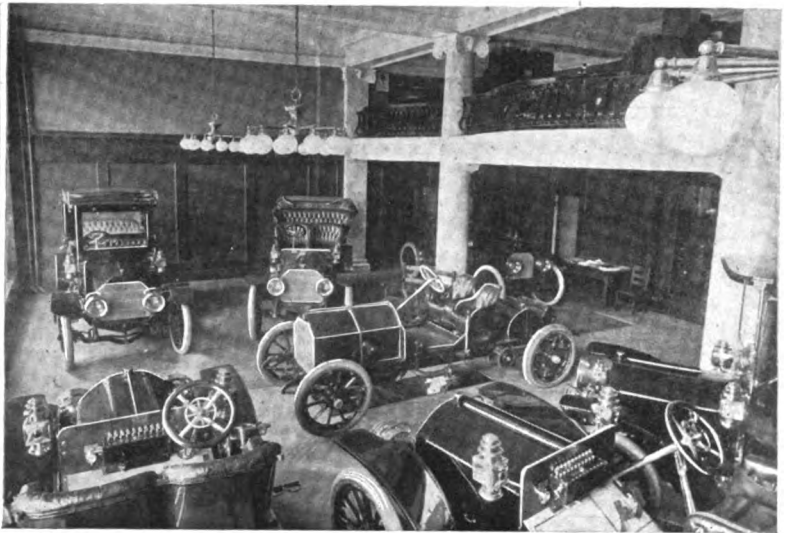

THE ATTRACTIVELY FURNISHED SALESROOM AND ITS MANY CARS.

### A REPRESENTATIVE NEW YORK HOUSE.

Though the development of the automobile has been extremely rapid, within the past few years facilities for housing it have been advanced at such a rate that the modern garage building is now a fitting home for the up-to-date car. That such an amount of money as is now invested in one of these buildings would ever be spent for that purpose would have seemed inconceivable but a few years since, and the number that have been put up is one of the strongest indications possible of the confidence prevailing in the future of the industry. The latest to reach completion, and likewise one of the most strikingly representative buildings of its kind, is the new establishment of the Palmer & Singer Manufacturing Company, located at 1620, 1622 and 1624 Broadway, and extending through to Seventh avenue, New York City. The building is constructed of solid, reinforced concrete, making it absolutely fireproof, and it is said to be one of the best-equipped establishments of its kind anywhere in the country.

Departing from the usual practice, the cellar has been utilized for a second washing room, being equipped with turntables and a washstand. It also contains three pits for the making of ordinary repairs such as would not necessitate sending the car to the repair shop in the upper part of the building, while buried beneath it, six feet underground, is the gasoline storage vault, fitted with six Bowser tanks and walled off by a fireproof partition from the remainder of the

building. In another section of the cellar are the boiler rooms and the motor rooms, both being walled off in the same manner. Another part of the equipment is a series of oil tanks with overhead cranes to facilitate handling barrels of oil of different grades. A high-pressure pump for feeding the roof tank and providing fire protection through its connection to the hose outlets on each floor is also located in the cellar, access to which is gained by means of the two large electric elevators. The latter have a capacity of six tons each and communicate with every floor of the building.

The salesroom is located on the ground floor, facing Broadway. As will be seen from the photograph, it has a capacity of several cars, with plenty of room to spare, and is one of the most attractively finished rooms of its kind in the city. The permanent display consists of 50-horsepower Simplex cars, three cars of the Palmer & Singer line, the "Six-Sixty" six-cylinder runabout, the "Four-Forty" touring car and the town car, also the Selden 28-horsepower touring car. Flanking the salesroom are toilet rooms and a ladies' retiring room, fitted with every modern convenience and beautifully finished. Behind the salesroom and occupying the remainder of the ground floor is the garage, entrance for cars being had by means of an extra wide door at the Seventh avenue end. By means of a special pump equipment the gasoline is raised from the cellar vault and transferred to small, portable, automatic measuring tanks of the Bowser type,



VIEW ON THE THIRD FLOOR SHOWING ITS GREAT CAPACITY.

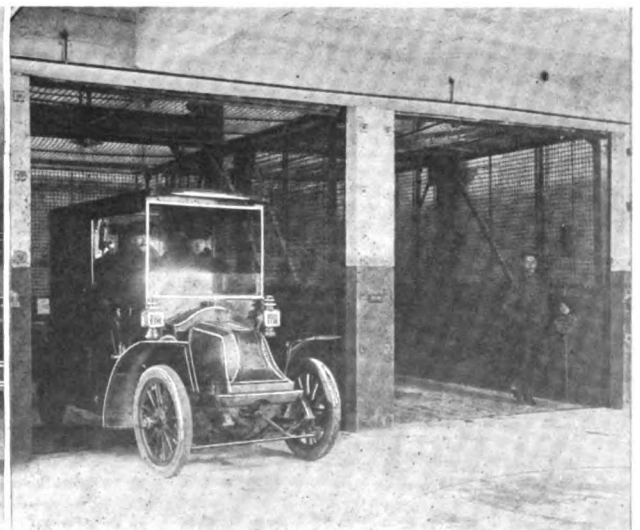

LIFTS THAT CARRY THE LARGEST CARS.



WHERE ALL PLANS ARE PUT ON PAPER.

which can safely be taken anywhere in the building. The superintendent of the garage also has his office on this floor, and there is a complete turntable and washroom equipment.

Running around three sides of this entire floor is a gallery carrying more than 150 lockers for drivers and owners, and having sufficient capacity to store clothing and spares. Access to this gallery is only to be had from the mezzanine floor of the salesroom, on which the business offices and fireproof vault for books and records are located. At the Seventh avenue end of the ground floor is a platform for the checkers, who keep track of the movement of every car.

The private offices of the company extend across the Broadway front of the second floor, and this may also be utilized as a salesroom. Behind this is another garage floor, and at the Seventh avenue end is the chauffeur's clubroom, containing a barber shop, two pool tables, shower baths, music room with piano, card room and a "temperance" bar. The third floor is devoted entirely to storage and has a capacity of more than sixty cars, besides having turntables and washstand like all the others. In fact, most of the washing will be done on this floor, so as to keep the others dry. The fourth floor is devoted entirely to storage, while the fifth floor is taken up by the machine shop, draughting room and combined stock and tool room. The machine shop occupies the major portion and is of such size that twenty cars may be under repair at once. The power-tool equipment is the most complete of its kind and includes every possible facility for the quick handling of cars. There are four full-length pits on this floor, so that that number of cars may be so placed as to be subject to examination from beneath at any part without the necessity of crawling under them.

KEYSTONE MOTOR CAR CO.'S NEW BUILDING.

PHILADELPHIA, Jan. 6.—Perhaps the feature that most impressed visitors at the recent opening of the new garage and salesrooms of the Keystone Motor Car Company, 216-220 North Broad street, this city, was the commodious appearance of every portion of the building. From the show room on the first floor to the machine and repair shop on the fourth floor there is every evidence of a judicious distribution of space. In the first place, the ceilings are high, the floor spaces are clear of any obstacle that might obstruct the view, and there is not a corner that is not flooded with light.



EXTERIOR OF NEW KEYSTONE GARAGE.

Entering the Broad street front show room, the visitor finds the cement floor covered with Persian rugs, artistically laid. To the right, just back of the mammoth windows, are displayed a number of 1908 Packards and Buicks, for which the Keystone Company is the Philadelphia representative. On

the left are the desks of the sales force and the accessories department. A spacious stairway takes the visitor to the balcony overlooking the show room. In the rear of the show room, doubling sliding doors connect to the garage room in the rear. The garage room is entered by a 40-foot passage in the rear from Carlisle street. There is no car entrance from Broad street.

The general offices on the mezzanine floor are finished in mission style, and the private offices of President Edward H. Godshalk and General Manager Clarence Godshalk are also located there. Nearby is an invitingly furnished ladies' room. The rear portion of the second floor is devoted to chauffeurs' quarters, fitted with every modern convenience. The gallery in the rear portion overlooks the garage room below.

The third floor is a single room, occupying the entire length and breadth of the building and is used as a stock room for cars, and the fourth or top floor is an admirably equipped repair shop and stock room. Large elevators connect all the floors and are capable of handling the largest closed cars with ease.



WHO WOULD NOT BE A CHAUFFEUR HERE?



ADMIRABLE ARRANGEMENT OF THE FIRST FLOOR FOR STORAGE.

**NEW CATALOGUES THAT HAVE BEEN RECEIVED.**

**Locomobile Company of America, Bridgeport, Conn.**—An excellent example of a trade catalog is provided in the publication of the Locomobile Company, descriptive of 1908 models. With text produced in black and red, the catalog is further embellished by colored engravings showing the finish of a number of Loco lines. That part of the book dealing with mechanical features of the new models is in sufficient detail to be valuable, and is at the same time so clearly written and well illustrated as to be understood by those with only limited experience. A pictorial representation of touring scenes in different parts of the world, with a Loco always in the foreground, adds considerably to the general interest of the book. A further publication from the same firm is an 1908 Locomobile color card issued with the assistance of the Murphy Varnish Company. This has been sent out as an aid to customers in ordering colors for new cars, and will be found useful as a supplement to the eight different color schemes shown in the firm's catalog.

**Lozier Motor Company, New York.**—The handsomely produced two-color catalogue of Lozier 1908 models, sent out by the Lozier Motor Company, New York, will appeal to a public desirous of getting real information on the make-up and design of this car. Descriptions are to the point and complete, and are further helped by numerous half-tone illustrations of various parts of the cars. The catalogue, which is printed on heavy book paper, has an embossed cover design showing the two crack Lozier drivers, Michener and Mulford. There are also a number of illustrations of scenes in twenty-four-hour and other contests in which Lozier took honors. A further publication from the same house is in the form of a little booklet based on a number of extracts from a recent number of THE AUTOMOBILE. Comments after each extract show how the Lozier has always led in design and construction.

**De Luxe Motor Car Company, Detroit, Mich.**—From cover to cover the catalogue produced under the title, "The Car De Luxe of To-day and Cars of Olden Times," is one of the most original as well as the most artistic of trade publications which have made their appearance this year. Excellently printed in two colors, each page gives a glimpse into the past and shows something of the present day product of the factory of the Detroit firm. It is in reality an artistic review of the progress of mechanical locomotion—a review got up in such excellent style as to commend itself to everybody.

**Cullman Wheel Company, Chicago.**—Forty-eight pages of closely printed matter are required to describe all the lines produced by these manufacturers of automobile and machinery sprockets. Among the features which attract attention are rear wheel sprockets and brake drums, also counter shaft sprockets for buggy automobiles. Another good line is the Cullman spur gear differential, which embodies among other new features an oil retaining shoulder and solid steel hardened pinions.

**Supplementary Spiral Spring Company, St. Louis, Mo.**—"Missouri Proof," consisting of a batch of letters from satisfied users of supplementary spiral springs, carries a strongly convincing message. Every one of the twenty letters reproduced contains enough praise for the device to convince the most skeptical. In issuing the booklet the firm declares that not one of the persons writing in praise of the springs is known to them or connected with the works in any way.

**Morgan & Wright, Detroit, Mich.**—The two chapters in the advance catalogue of the well-known Detroit tire firm are headed respectively "In General" and "In Detail," the former dealing with some of the generalities of tire construction and the latter showing the different lines produced by Morgan & Wright, comprising the Bailey, Midgley, flat and

plain treads. What some people have been able to do with these tires is told in a couple of pages of testimonials.

**Standard Roller Bearing Company, Philadelphia.**—Some of the various types of tapered and straight roller bearings, annular ball bearings, ball and roller thrust bearings are dealt with in the automobile show catalogue of this firm. But the activities of the company are not limited to this, some of the other features mentioned in the illustrated catalogue being gear blanks, drop forgings, front and rear axles and transmission gear.

**Adams Company, Dubuque, Ia.**—"The Sages," a handy little folder about the Adams-Farwell revolving air-cooled motor, does not deal much with technicalities or present any illustrations, but is none the less interesting for all that. It is but a series of pointers on the features of the Adams-Farwell, served up in such a way that one is tempted to ask for more particulars.

**Rock Island Tool Company, Rock Island, Ill.**—Catalogue "D," just issued, deals with this company's very extensive line of vices, all of which are described and illustrated. One of the most attractive things in the catalogue is an automatic self-locking swivel vice, which, with no more parts than the ordinary stationary vice, offers immense advantages over this latter.

**Hartford Rubber Works Company.**—A feature of the colored booklet of this company is a series of illustrations showing how Hartford solid tires are employed on every type of mechanically propelled and horse-drawn vehicle. In addition to a talk on Hartford excellence, there is some useful information on how to mount these tires on their rims or dismount them.

**Raines & Co., New York.**—Four bright little maidens symbolize the brightness produced by Globe metal polish, on the colored hanging calendar for 1908, produced by the makers of that indispensable garage toilette preparation. Raines & Co., 50 Ferry street, New York, makers of Globe polish, will doubtless be willing to supply copies of the calendar on request.

**Motz Clincher Tire & Rubber Company, Akron, Ohio.**—As evidence of the value of their cushion tire, this firm has published a chart obtained after a series of comparative tests by an electric vehicle firm with several makes of tires. The inquiry was entirely disinterested and the favorable showing of the Motz is therefore all the more worthy of attention.

**Nordyke & Marmon Company, Indianapolis.**—A view and description of the factory at Indianapolis, Ind., a review of the structural features of Marmon air and water-cooled models, and specifications of the various types of cars comprise the main features of Marmon catalogue No. 830-A. Several illustrations are given of the complete cars.

**Eldredge Electric Manufacturing Company, Springfield, Mass.**—A catalogue of battery testing instruments recently sent forth comprises pocket voltmeters, ammeters, voltammeters, spark-coil current indicators, miniature switchboard instruments, etc. Each instrument is illustrated, described in detail and price given.

**Gilbert Manufacturing Company, Hartford, Conn.**—The catalogue for the 1908 season shows all the well-known lines of leather and metal goods for automobiles, as well as a number of novel features likely to be valuable on any car. Gilbert high quality is declared to be maintained in all standard and new lines.

**R. M. Owen & Company, Lansing, Mich.**—There is a convincing air in what the catalogue compiler has written on the Reo family for 1908. There are five of them, from a little single-cylinder runabout to a comfortable four-cylinder side entrance touring car. Parts and complete cars are freely illustrated.



## ANOTHER EFFORT FOR A NATIONAL HIGHWAYS COMMISSION

WASHINGTON, D. C., Feb. 10.—Automobilists throughout the country will undoubtedly accord hearty support to the bill introduced in Congress by Representative Currier, of New Hampshire, the object of which is to create a National Highways Commission, and for the construction, improvement, and maintenance of public highways. The plan suggested by the Currier bill is a novel one and if it is enacted into law will work wonders in improving the condition of the National Highways.

The proposed commission is to consist of three members, to be appointed by the President of the United States, who are to receive a salary of \$5,000 a year, and can only be removed from office for cause. It will be the duty of the commission to take into consideration, formulate, and adopt such plan or plans for the improvement, construction, and maintenance of such public highways, the improvement and maintenance of which shall in the judgment of the commission, acting in cooperation and consultation as far as possible with the duly constituted authorities having

charge of the highways of the several States, promote and facilitate inter-state commerce and trade and the postal service.

The commission is given authority to cause proceedings to be instituted in the name of the United States for the acquirement by condemnation of any land, right of way, or material needed to enable it to prosecute works for the construction and improvement of public highways.

The bill also appropriates \$50,000,000 for carrying out its provisions. The sum of not less than \$500,000 out of such appropriation shall be expended in each State, said sum to be expended in each State at the rate of not less than \$100,000 a year. The \$50,000,000 appropriation is to be available at the rate of \$10,000,000 a year during the years 1908 to 1912, inclusive. The bill also provides for the detail of officers from the engineer corps of the army to assist the proposed commission in carrying out its projects. The bill is to take effect thirty days after its enactment, and if passed would be of benefit to the good roads movement.

## MANITOBA FARMERS ASSIST IN ADOPTING A SANE LAW

WINNIPEG, MAN., Feb. 10.—Automobile laws framed by farmers, or by the constitutional representatives of agricultural interests, have so generally been monuments of stupidity, bigotry and narrow-mindedness that the first motor act adopted by the province of Manitoba may be put up as a model for less enlightened districts. The members of the Local House which passed the bill, about 90 per cent. of whom are representatives of, or farmers themselves, are to be congratulated on an act conspicuous for its saneness, broad-mindedness and liberality.

All automobiles must be registered with the municipal commissioner, the initial fee being \$5, and yearly renewals \$2, with a provision for payment of the smaller fee when a car changes hands during the year for which its license has been issued. Numbers must be carried on the front and rear as well as on the front lamps. Chauffeurs or hired drivers must obtain a certificate of registration authorizing them to operate a motor vehicle; before obtaining such they must prove that their eyesight and powers of hearing are in no way defective.

In the open country *no speed limit is imposed*. In central parts of all cities and towns through the Province the limit is 10 miles an hour; in suburban districts the limit is 15

miles and at corners four miles an hour must not be exceeded. At any place when meeting a horse-drawn vehicle the act stipulated that the speed must be cut down to six miles an hour within 300 yards of the vehicle and kept at that speed until the vehicle is passed. When an automobile is overtaking a horse-drawn vehicle the slower conveyance shall give right of way as soon as practicable. A car standing at any place in cities or towns must have its engine stopped in order to prevent accidental starting by mischievous persons.

*Road races may be held by permission of any municipal body* by a resolution passed in the council giving the necessary authority. Clause 39 in the original bill has been eliminated, as it was thought manifestly unfair to make an owner responsible for damages caused by his car when it was being driven without his knowledge or consent.

The fines for violation of the by-law has been fixed at a sum not exceeding \$25 for the first offense and \$50 for the second or subsequent offense, but it is left to the discretion of the magistrate to inflict a minimum fine where the offense is only of a technical nature. Three convictions will have the effect of cancelling the license for a period of one year or less, at the discretion of the municipal commissioner.

## SQUIRE'S CASE WENT TO HIGHER COURT.

PHILADELPHIA, Feb. 10.—On December 27 last Frank P. Young, a local automobilist, voluntarily appeared before Squire Joseph Keen, of Hulmeville, Bucks County, to answer a charge of having failed to "honk-honk" at several street intersections in that borough, as provided by the law of the State. The alleged offense had occurred the previous August, and Young decided to fight the case. Despite a vigorous defense by his counsel, G. Douglas Bartlett, the squire, an inveterate auto-baiter, after his listening perfunctorily to the evidence, imposed the stereotyped penalty—\$10 and costs. In the latter was included the sum of \$1 for serving warrant. As Mr. Young had appeared voluntarily no warrant had been necessary, and lawyer Bartlett hauled the magistrate up for exacting an illegal fee. The old squire was given thirty days to pony up the \$50 damages. The time expired last Monday. Squire Keen, however, carried his case to a higher court, for he died suddenly on Sunday.

## ONE VIEW OF AUTO SMOKE ORDINANCES.

"That's about as foolish a move as can be imagined that Mayor McClellan made in New York when he started to secure legislation that will punish automobilists for driving a car out of which smoke will come for a longer period than ten seconds after the car starts," said Designer W. W. Kelley, of the Wayne Automobile Company, of Detroit.

"In the first place, smoke coming from the exhaust pipes is not an evidence of carelessness or incompetence. This smoke in many cars is due to the fact that the crank cases are so shallow that to have sufficient oil in them it must reach a high level. To prevent this smoking would be simply impossible. And in a large number of big cars it would be impossible to prevent smoking at certain times. There's nothing particularly wonderful about a car that does not smoke, and there's nothing particularly bad or obnoxious about a car that does smoke. It seems like splitting hairs to even hint at such a thing as passing a law to prevent it.

## ANNUAL REGISTRATION FOR NEW YORK STATE

ALBANY, N. Y., Feb. 10.—Two years ago the automobilists of New York State, through their organization, placed themselves on record as being in favor of an annual registration fee, providing the money was used in the maintenance of the roads already improved.

In the most comprehensive report of the joint committee of the Senate and Assembly, "appointed to investigate the subject of codifying the general and all special highway laws and to provide for a system of highway improvement, their construction and maintenance," there is a paragraph referring to automobiles, and it reads as follows:

**Tax on Automobiles.**—During our examination of the general subject of highways and their maintenance evidence was presented from almost every section of the State indicating that the use of automobiles upon the improved highways was a source of wear and tear upon the surface which, with their constantly increasing use, would require special attention to be given to this branch of the subject. In wet weather when, for the safety of the automobilist, he is required to use chains upon the slippery pavement of the city or in the mud of the dirt road in the country whenever he strikes an improved highway he does not stop to remove the chains from the driving wheel so that when the improved highway is wet, and, therefore, readily subject to the attack of the links of the chain, its use is injurious to the improved highway; while during dry weather there is a possibility that the road will ravel because while the slow-moving vehicle might slightly disintegrate the surface the automobile, moving at a high rate of speed, produces a suction which removes the dust and finer particles of the wearing surface and thus leads to a raveling of the top course. Already experiments are being made by local officials in various sections of this State, and also in Massachusetts, Connecticut and New Jersey, with reference to the determination of what sort of special treatment may be given to through highways so that they are able to resist this peculiar sort of wearing away of the top surface which comes from the suction produced by the rapidly moving machine.

It is, therefore, clear to your committee that at this session of the Legislature appropriate legislation should be had which will regulate the use of chains upon improved highways and also, inasmuch as there must be special treatment or special construction upon the through highways, it would seem only fair that a reasonable tax should be levied to provide a fund from which this extra burden may be discharged. That legislation should be reasonable as to the amount of the tax, it should be definitely provided that it

is to be spent for the repair to the end that the automobile may bear its just proportion of the burden for any increased wear upon the highway, and, on the other hand, that the payers of the tax may have a guarantee that the money so paid is to be expended for the remedying of the condition which they create.

In considering this question your committee is of the impression that inasmuch as the legislation with reference to motor vehicles is now to be found in a separate law that the proper place for these suggested changes is by amendments to the Motor Vehicle Law. Logically, these provisions of statute should be found in that law rather than in the Highway Code.

At the meeting of the special legislative committee of the New York State Automobile Association, held several weeks ago, it was decided to incorporate an annual fee in the bill which will be introduced in the near future, and therefore the suggestion of a yearly fee in the report of the Joint Highways Committee is acceptable to the autoists, who are also greatly interested in the definite plan suggested for the building and maintenance of the roads and the expenditure of the fifty millions available for the purpose. The chains proposition may be a subject for discussion.

Chairman Jotham P. Allds is a legislator who has been long in harness, reasonable in automobile law-making, and an enthusiast on the subject of roads. Summarized, the report of his committee is reassuring to automobilists who have been discouraged at the slow progress in New York State:

**Summary.**—The proposed Code provides for a State highway department to be appointed in the month of January, 1909, by the incoming Governor. It provides for either county or district superintendents having charge of small area. It provides a uniform fiscal year with town superintendents to take office practically at the time that the new fiscal year commences. It preserves to the locality the regulation of the incurring of extraordinary expenditures, but it also enforces a more intelligent method of expenditure when the same has been duly authorized and also guarantees to the locality more certainty with reference to the annual repair of improved highways. It divides all highways into three classes—the State, county and town highways. The State highways to be built and maintained by the Department at State expense. The county highways to be selected originally by the several county boards of supervisors, and when approved by the State Department, to be built under the provisions found in this act, which were heretofore found in the Higgle-Armstrong Good Roads Act. All other roads to be repaired and maintained by the local authorities under the direction of the Department and under the general superintendence of the county or district superintendent. Said work to be done on the money system and giving to each town the benefit of aid by the State in accordance with the general provisions of what has been commonly known as the Fuller-Plank Law.

## AMERICAN AUTOMOBILES SOLD IN 1907 WORTH \$105,000,000

AT both the meeting of the Association of Licensed Automobile Manufacturers and the National Association of Automobile Manufacturers, held February 5 in New York City, the outlook for 1908 was freely discussed. M. J. Budlong, general manager of the Licensed Association, when seen after the meeting, was emphatic in his conclusions that if the general policy of conservatism, coupled with rational business methods and a proper commercial practice were adhered to, the business for 1908 would not only equal but be larger than that of 1907.

Records and statistics for 1907, just completed by the Licensed Association, show to what extent the industry has grown the last year or two. During the fiscal year of January 1, 1907, to January 1, 1908, there were 47,302 pleasure gasoline cars manufactured in this country. The aggregated value is \$96,169,572. During this same period there were 5,000 steam and electric pleasure vehicles built and sold in this country, with a total value of \$7,500,000, this giving a

total of 52,302 pleasure automobiles sold in the past twelve months, with a total value of \$105,669,572.

The percentage of increase each year has been consistent, as shown from statistics gathered in 1904, which show the value of the total output \$26,645,064 as against \$105,669,572 for the past year. It is estimated that the total number of employees directly employed in the factories is 58,000 and the capital employed \$94,200,000.

As in many other manufacturing products, there is an indirect investment which is closely allied to vehicle manufacture. Close estimation shows that there are 29,000 employed in this indirect manufacture, with total capital employed of \$36,700,000. At the close of the year 1907 there were 2,151 sales and garage establishments employing 21,500 people, with a capital of \$57,500,000, employed to do business.

Not including accessories, the total estimation is: Value of product sold, \$105,669,572; total capital employed, \$171,448,769; number of employees involved, 108,500.

### COMPANIES PLANNING REORGANIZATION.

HARTFORD, CONN., Feb. 10.—Though nothing definite has been made public as yet, it is understood that the Pope Manufacturing Company and the Electric Vehicle Company of this city will shortly be reorganized on a sound working basis. Where the former is concerned, it is understood that the plans in view contemplate the retirement of Colonel Albert A. Pope, the founder of the business, and the continuance of the Hartford and Westfield, Mass., plants, under the management of A. L. Pope, while the Toledo, Indianapolis and Hagerstown plants will be disposed of. It is said that the profits of the company last year amounted to \$400,000, so that no difficulty is anticipated in reorganizing it.

Though the prospects are good, matters are not so easy with the Electric Vehicle Company. According to a report, it was the intention of William C. Whitney to reorganize the company four years ago, and the plan was about to be carried through when further action was halted by his untimely death. The amount of working capital necessary for the company to resume is said to be \$250,000, and it is anticipated that dividends could readily be paid on a capitalization of from \$2,000,000 to \$3,000,000. One-third of its present stock is held by the Electric Storage Battery Company of Philadelphia, a wealthy concern, while its other principal stockholders are Grant B. Schley, Harry Payne Whitney and Thomas F. Ryan. These stockholders have been carrying a heavy mortgage on the plant and business for several years. It is said that this does not cover the Selden patent, and the prospects of the creditors would appear to be somewhat dependent upon the latter to produce a steady income. During the recent stringency it has been found necessary to permit some of the licensees to defer their payments, and there is also understood to be a demand for a lower percentage of royalty, so that the extent of the income from this source during the remaining four years of the life of the patent is hard to determine.

### ROCHESTER TO HAVE ITS FIRST SHOW.

ROCHESTER, N. Y., Feb. 10.—The New Convention Hall, now rapidly nearly completion, will be the scene, on March 18-21, of Rochester's first automobile show, held under the auspices of the Rochester Automobile Club.

### SAYS AUTOS ARE REPLACING SLEIGHS.

BUFFALO, Feb. 10.—"The automobile industry is advancing in leaps and bounds in this country now," declared F. A. Babcock, president of the Babcock Electric Carriage Company, at a chance gathering of a number of automobile men at the Hotel Iroquois in Buffalo the other day. "Just think," he continued, "it wasn't more than three or four years ago that when Winter came the owner of an automobile meekly put his car up for the season, gave up all idea of pleasure riding, and had recourse to the train or trolley while attending to his daily business.

"But the case is different now. I venture to say that less than ten per cent. of the auto owners here in Buffalo have put their cars up. The enclosed body is what did it. And then the improvements in wheels and tires and the adoption of the non-skid chain have eliminated the danger that snow used to present to the automobilist. You see the women down in the shopping district every day now coming in their limousine or coupé, and paying no heed to the cold or snow.

"I am not one of those visionaries that think that the automobile means the passing of the horse. But there is one thing that I think the automobile will displace: that is the sleigh. Just recall how few sleighs were out on the avenues and in the parks, even when the going on runners was excellent. The sleighs have to stay in the background now that our automobiles are such that they can be used in Winter as well as in Summer."

### REAL ESTATE AGENT'S PROFITABLE AUTOING

NEW HAVEN, CONN., Feb. 10.—A decidedly new stunt in the real estate business has been sprung upon this old university town by C. D. Hall, one of the city's youngest and most progressive real estate men. Mr. Hall's stunt is a Knox automobile, which he employs exclusively in his business. He says that he is able to do about three times the business with the auto he was formerly able to attend to, at a greatly reduced cost. He claims the car quickly saves its initial cost many times over by the vastly increased business. It is stated that several other real estate men are to employ autos in their business and that once the advantages of the new way of showing property becomes known, it will become popular.



HOW FAR-FAMED "JACOB'S LADDER" IN THE SNOW-CLAD BERKSHIRES LOOKED LAST WEEK FROM A 1908 THOMAS FLYER.

## THE AUTOMOBILE CALENDAR.

## AMERICAN.

## Shows and Meetings.

- Feb. 17-22.....—Cleveland, Central Armory, Annual Show, Cleveland Automobile Dealers' Association. George Collister, manager.
- Feb. 21-29.....—Newark, N. J., Electric Park Auditorium, New Jersey Automobile Trade Association and New Jersey Automobile and Motor Club.
- Mar. 7-14.....—Boston, Mechanics' Building and Horticultural Hall, Boston Automobile Dealers' Association. Chester I. Campbell, manager, 5 Park Square.
- Mar. 11.....—Boston, Bay State Auto Association Clubhouse. First Quarterly Meeting, Society of Automobile Engineers.
- Mar. 9-14.....—Buffalo, Convention Hall, Sixth Annual Automobile Show, Automobile Club of Buffalo. Dai H. Lewis, manager.
- Mar. 18-21.....—Rochester, N. Y., New Convention Hall, First Annual Show, Automobile Dealers' Association and Rochester Automobile Club. Bert Van Tuyle, manager.
- Mar. 21-28.....—Toronto, Canada, St. Lawrence Arena, Automobile Show. R. M. Jaffray, manager.
- Apr. 5-12.....—Montreal, Canada, Arena, Third Annual Automobile and Sportsman's Show. R. M. Jaffray, Mgr.
- April 6-8.....—Denver, Mammoth Rink, Annual Automobile Show. G. A. Wahlgreen, manager.

## Race Meets, Hill Climbs, Etc.

- Feb. 22.....—Boston, 150-mile Endurance Run, Bay State Automobile Association.
- Feb. 25.....—Brooklyn, N. Y., Economy Run Montauk and Return, Long Island Automobile Club.
- Mar. 2-7.....—Ormond-Daytona, Fla., Automobile Club of America.
- Mar. 18-19.....—Savannah, Ga., Savannah Automobile Club.
- Apr. 24.....—Briarcliff Trophy Race, Westchester County, N. Y. Robert L. Morrell, chairman.
- May 4-5.....—Harrisburg-Philadelphia and Return, 150-mile Endurance Run, Motor Club of Harrisburg.
- May 15.....—Chicago, Algonquin Hill Climb, Chicago Motor Club.
- May 30.....—Bridgeport, Conn., Sport Hill Climb, Bridgeport Automobile Club.
- June 24-27.....—Chicago, 1,200-mile Reliability Run, Chicago Motor Club.
- Sept. 14.....—Chicago, Annual Economy Run, Chicago Motor Club.

## FOREIGN.

## Shows.

- Mar. 21-28.....—London, Agricultural Hall, Cordingley's Show.
- May 17-June 2.....—Moscow, Russia, International Automobile Exposition, Automobile Club of Moscow.

## Race Meets, Hill Climbs, Etc.

- April 1-13.....—Monaco Motor Boat Races and Motor Boat Exhibition, International Sporting Club of Monaco.
- April 25-May 25.....—Industrial Vehicle Competition, Automobile Club of France.
- May.....—Paris, Competition for Agricultural Automobiles, auspices of "L'Auto." (Date to be announced.)
- May 10.....—Sicily, Targa Florio, Automobile Club of Italy.
- June 1-18.....—Reliability Trials for Pleasure Cars, Automobile Club of Great Britain.
- June 9-17.....—Touring Competition for the Prince Henry of Prussia Prize, Germany, Imperial Automobile Club of Germany.
- July 7.....—Voiturette Grand Prix, Dieppe Circuit (Automobile Club of France). Date not yet officially confirmed.
- July 8.....—Grand Prix of Automobile Club of France, Dieppe Circuit. Date not yet officially confirmed.
- July 13-17.....—Ostend, Belgium, International Race Week, Automobile Club of Ostend.
- July 20-30.....—Ardennes Circuit Races and Coupe de Liedekerke, Automobile Club of Belgium.
- Aug., 1908.....—France, Coupe de la Presse, Automobile Club of France. (Exact date to be announced.)
- Aug. 23-30.....—France, Mont Ventoux Hill Climb, Vauclussen Automobile Club.
- Sept. 1-8.....—French Voiturette Contest, auspices of "L'Auto."
- Oct.....—Berlin, Germany, Gordon-Bennett Balloon Race, Aeronautical Club of Berlin.

## BOOKS FOR AUTOMOBILISTS.

**Distillation of Alcohol.**—With the passing of the act of June 7, 1906, which freed denatured alcohol from the disability it had previously labored under, a new market was opened up for the farmer and manufacturer, and the want was felt for practical information on processes of distillation. F. B. Wright's "Distillation of Alcohol and Denaturing," which did much to meet the want, has just been reprinted, the second edition being a careful revision of the first, with new chapters and considerable amplification on the most modern of methods and appliances in this country and Europe. The design of the author in compiling the second volume has been to follow the original plan of writing a plain, practical handbook on the manufacture of alcohol and denaturing for industrial purposes, the work being intended not as a scientific treatise, but as a help to farmers and others wishing to go into this industry on a moderate scale. That object has been fully attained, the subject being handled comprehensively, clearly, and made additionally valuable by numerous drawings. The book is published by Spon & Chamberlain, 123 Liberty street, New York.

**A Handbook on Automobile Repairs.**—Automobilists who aim at being so completely master of their car that they will be independent of the repairman except for serious breakdowns, will find considerable educational value in "Practical Motor Car Repairing," an illustrated handbook published by Percival Marshall & Co., of London, and sold in New York by Spon & Chamberlain, of Liberty street. The work, which is compiled more with a view of meeting the wants of the amateur than the professional repairman, deals with the commoner weaknesses and defects of an automobile and tells in a simple manner how they may be remedied.

## "WINDY BILL" WILL CHAMPION THE MULES.

Editor THE AUTOMOBILE:

You will find clipping from the Louisville Evening "Times" which I thought might be of interest to your readers. However, do not think there is any danger of any sane body of men passing such a law, and even if they should, I give the Governor of this State the credit of having too much common sense to allow it to become a law. Would suggest that "Windy Bill" go back to his lop-eared mules, where I am sure he can get lessons in common mule sense he seems to be sorely in need of.

J. H. BOVARD.

Newcastle, Ky.

FRANKFORT, KY., Jan. 14.—Automobiles will have to remain in the woodshed if a bill which is to be introduced by W. M. Thompson becomes a law. Mr. Thompson, who is known as "Windy Bill," and who has a voice, when it is in condition, that reflects great credit on its owner, says that so many autos have been running over the State, and especially his county, that they have become a menace to the lives of the people and he would put them in the class with traction engines.

The bill which is being framed by Mr. Thompson is a lively one. It will provide that a man must go ahead of each automobile and keep one hundred yards in advance of it, on foot, all the time so as to warn persons along the route that the engine is coming. The machines will not be allowed to travel at a rate of speed greater than three miles an hour, and no more touring parties will be permitted.

Mr. Thompson thinks that he can get the bill through the two houses and will make a speech in support of it, in which he will touch on the "dreadful horrors of the automobile and the immense damage it does to the nerves of mules and persons driving the mules." Mr. Thompson represents Bullitt and Spencer counties.

## ANENT THE WOES OF THE GARAGEMAN.

"We certainly do have troubles of our own," wearily assented the garage keeper to the sympathetic feeler ventured by the reporter in search of a story. "Between a lot of old ladies who have nothing to do but spend their money, and who can't understand why a week's work on a car should cost more than the price of a Paris outfit, and the people who can't afford to keep a car anyway, the pot is kept boiling for us pretty steadily, and we are seldom out of hot water. I'll tell you how it is—here's another of 'em now. Come around some other time and I'll fix you up."





Vol. XVIII Thursday, February 13, 1908 No. 7

THE CLASS JOURNAL COMPANY

Flatiron Building, Madison Square New York City

H. M. SWETLAND, President

EDITORIAL DEPARTMENT

A. G. BATCHELDER, Managing Editor R. F. KELSEY, Associate Editor C. B. HAYWARD, Engineering Editor W. F. BRADLEY

BUSINESS DEPARTMENT

A. B. SWETLAND, Business Manager LOUIS R. SMITH FRANK B. BARNETT W. I. RALPH, 1035 Old South Building, Boston, Mass. C. H. GURNETT, H. E. WESTERDALE, 836 Monadnock Block, Chicago, Ill

Cable Address Autoland, New York Long Distance Telephone 300 Gramercy, New York

SUBSCRIPTION RATES:

United States and Mexico One Year, \$3.00 Other Countries in Postal Union, including Canada, One Year, 5.00 To Subscribers—Do not send money by ordinary mail. Remit by Draft Post-Office or Express Money Order, or Register your letter.

FOREIGN SUBSCRIPTION AGENTS:

ENGLAND:—Hillife & Sons, Limited, 29 Tudor Street, London, E. C. FRANCE:—Boyveau & Chevillet, 22 Rue de la Banque, Paris. GERMANY:—A. Seydel Mohrenstrasse 9, Berlin.

Copyright, 1907, by The Class Journal Company. Entered at New York, N. Y., as second-class matter. The Automobile is a consolidation of The Automobile (monthly) and the Motor Review (weekly), May, 1902, Dealer and Repairman (monthly), October, 1903, and the Automobile Magazine (monthly), July, 1907.

Table with 2 columns: Year (1905, 1906, 1907) and Copies printed (730,000, 791,000, 888,900)

AUTOMOBILE LAWS OF TWO STATES:

Connecticut and New Jersey represent the opposite points of the compass in automobile legislation: one State accepts the motor-driven vehicle as a pleasurable and commercial necessity; the other commonwealth grudgingly gives it place in the general scheme of transportation. In several respects the conditions brought about by the coming of the automobile are analogous in both States.

Connecticut intervenes between New York and Massachusetts, and in consequence its excellent roads are traveled by the thousands of automobiles which yearly repeat the journey having New York City and Boston as destination points. New Jersey likewise supplies much frequented trunk roads used by automobiles circulating between New York City and Philadelphia.

Connecticut possesses summer resorts in plenty; New Jersey's coast has numerous part-year colonies and the largest hotel population of any State in the country.

Both States have been progressive in the building of roads, and it is natural that they should be vitally concerned as to the mileage exacted from these highways by the vastly increased traffic, for keep in mind that a hundred vehicles will wear out a road much more quickly than one-tenth of that number.

And thus are the laws of the two States different:

Connecticut welcomes the visitor if he be registered in his home State; New Jersey calls for the fee as soon as he quits the ferryboat.

Connecticut has erased all speed technicalities below twenty-five miles an hour, except to ask fairly that at all times the operator shall not drive to the danger of other users of the road; New Jersey reiterates insistence of the "eight miles per hour," etc., despite the fact that every vehicle which moves violates this provision, the real value of which, however, is based on the lucrative operation of "traps" in places where traffic is meager.

Connecticut does not find it essential to require of its home or visiting autoists any power-of-attorney clause to insure the punishment of offenders, and the working of the new law has not caused any proposal looking forward to an adoption of this most objectionable feature of the New Jersey law, which has kept many an automobile owner out of that State.

When one takes note of the fact that Connecticut's husbandry is a most powerful factor in the legislature because in that State its law-making body is constructed on the old plan whereby every township has two representatives no matter what its rank in population, there must come a realization of the liberal and common-sense spirit of its farmers, whose antagonism to automobiles subsided as soon as their horses became accustomed to the new user of the road. Then, this wideawake commonwealth has a highways commissioner by the name of McDonald, who, along with the agriculturists, recognizes without quibbling that the automobile is here to stay and that if the present road does not meet the demands of the more trying traffic there must be a solution of this new problem in roads building.

It may pay the State of New Jersey to retain its rigid requirements, repelling and not inviting the automobilists from other States, but any method of bookkeeping which it can employ to show a profit is not finding acceptance elsewhere, and even in its own boundaries there will be found not a few dissenters. What the State unsuccessfully asks from visitors in registration fees is lost many fold to its merchants.

It is praiseworthy for the Governor to express himself in favor of a tire tax to cover all vehicles and further stipulate that they shall carry lights at night, but from the standpoint of commerce, if for no other reason, the chief executive will serve better his State if he assists in bringing about reciprocity in registration, abolishment of traps by doing away with the farcical "miles per hour" in its lesser speeds, and eradicating the power-of-attorney clause.

New Jersey may consider that it can afford to place itself in the same position as the single jurymen who explained the failure to reach a decision by saying that he had "never before met eleven such obstinate men." While to some the words of Hotchkiss and Terry at the banquet of New Jersey's largest club may have sounded scathing and unpleasant, many will admit that the indictment was based in fact, even though their Governor took the floor a second time to defend a law in the making of which he had had no part.

But it is pretty good figuring that many when planning their runs the coming season will wend their way Connecticutward instead of entering a State which believes in uniform laws only when other States accept its statutes.

## NEW JERSEY CLUB'S BANQUET HONORED BY A GOVERNOR

NEWARK, N. J., Feb. 10.—Automobilists of this State are still discussing the banquet last Thursday night of the New Jersey Automobile and Motor Club, held at Achtel-Stetter's and attended by over two hundred members and honored by the presence of Governor Fort, who is looking into the automobile question with considerable care. The present so-called Frelinghuysen law has been less acceptable to outside autoists through reason of the power-of-attorney and non-reciprocal registration clauses than to home owners, who have made the best of the situation and fared fairly well through the reasonable interpretations of Commissioner of Motor Vehicles Smith. Therefore, the drastic criticism of the State law made by William H. Hotchkiss, president of the American Automobile Association, and the plea for a uniform statute presented by Charles Thaddeus Terry, chairman of the national body's Legislative Board, while listened to with marked attention, did not arouse that unanimous approval which would have been unquestionably the case had the listeners consisted of non-residents.

Though Governor Fort had previously contributed an opening talk which was greeted with pronounced favor, especially his references to a tire tax for all vehicles and a law calling for the carrying of lights at night, he resented the remarks of the speakers following him, and while he had had nothing to do with the framing of the existing law, the chief executive arose to its defense and made it clear that he did not agree with the plain language of President Hotchkiss or the incisive suggestions of Chairman Terry. It was a situation in which a governor considered that his State had been attacked, and, of course, he retorted.

As to whether Governor Fort will retain, after closer observation, his expressed belief in the criticised features of the law is a matter for the future to determine. There is well-grounded belief that even Senator Frelinghuysen does not now consider the law with which he had so much to do with the making entirely up to date, and if the clubs of the Associated Automobile Clubs of New Jersey can bring about the proposed conference with that astute statesman there is hope that an understanding may be reached which at least will mitigate some of the provisions now so bitterly complained of.

President Hotchkiss is a man of strong convictions, as the following extracts from his speech, entitled "Jersey Justice," make evident:

Jersey Justice! The rogue, 'tis said, here has short shrift, the punishment always fits the crime, wrong is done no man, and common sense is law. And you sum it all up in the phrase: "Jersey Justice."

Still, somehow, a New Yorker and a motorist may be excused the question—and in all seriousness—what's wrong with Jersey Justice when applied to motor users, particularly those from other States? Your people are not unlike ours, many of you pass the days in our metropolis; your streets, your municipal services, your buildings, your general laws are much the same; and, to-night, this Lucullan board and this your generous hospitality—why, even New Yorkers could do no better, perhaps, not so well. More, as I stepped from the ferry and walked to the train to-day, I was not halted and asked whether I had registered and been tagged from Trenton, though the officer on guard must have guessed that I would, ere long, help wear out your sidewalks, be guided by the radiance of your street lights, and enjoy the protection of your police. And yet, I was not stopped and numbered! Nor has any peace officer yet demanded that I execute a power of attorney to some unknown official over on the Delaware through whom New Jersey could retain jurisdiction of my body and property in case I might heedlessly violate your laws or accidentally invade the rights of Jersey men. So for me, to-night, it's: Hoch to Jersey Justice! For, gentlemen, let it be recorded that, on this day of grace, the sixth of February, nineteen hundred and eight, a New Yorker and a motorist boarded a ferry boat, with deliberate intent to use your streets and sidewalks and purloin from you, for the time, all those public services which make modern life so easy, and that, after using them as freely as the air he breathed, he is

here in Newark to-night, unlicensed, untagged, unattorneyed—and still at large. You know the reason. Like tens of thousands more, in setting out for New Jersey, he left his automobile at home.

And so I again ask: What's the matter with New Jersey in dealing with the motor car? Prejudice has existed in New York, rustic Dobbins still sometimes shy at the newfangled wagons, drastic ordinances have been passed, and weird laws enacted, and at times enforced. Yet, for nearly four years, our motor vehicle law has proved so acceptable as not to require amendment—framed by motorists it was passed unanimously by a Legislature dominated by the farmer vote—strangers are free to use our roads, without registration or tax; motor vehicle licenses, with us, are unheard of; accidents, save in congested territories, relatively rare; speed traps, except on the borders of the Greater City, all but unknown; and the time seems rapidly approaching when the present automobile law of New York will be as dead a letter as is the bicycle law.

Not so in New Jersey. You enforce literally the miles-per-hour speed clause. Result: A good friend of mine, accustomed to the sane Buffalo rule, which commands rather a due observance of the conditions of the highway and the traffic thereon at the time, made seven contributions to Jersey justices in one day last summer, for real or speed-trapping violations of law, and vows heretofore to keep himself and his purse beyond your borders. You use the excuse of necessary identification to tax all outlanders, and thousands voice their protests by spending their money elsewhere. But, most unreasonable of all, by the power-of-attorney requirement, you refuse the right which, for nearly fifteen centuries, the average man has had to a trial in civil suits, by a jury, not merely of his peers, but of his neighbors. And, when they learn of cases where heavy default judgments have thus been obtained, because of unknown and sometimes imagined injuries, thousands more will resent this cruel and unusual requirement—I had almost said punishment—and hie themselves, their cars, and their cash to more reasonable and more hospitable States.

### Co-operation Among Motorists Necessary.

What's the matter with New Jersey?

First, there has not been that co-operation among motorists themselves, by which alone unreasonable laws may be prevented; you have not made the proper regulation of the motor vehicle your business, each winter, in the Legislature, each month of the year, in assisting the proper enforcement of the ordinary rules of the road. But, this is not the place to chide; and you are, I'm told, now cementing an organization for these purposes.

Second, there are reasons far more potent. In New Jersey, the prejudice of the horse and his owner—that of the horse the stronger of the two—have not, as elsewhere, materially decreased; while the desire for revenue from outlanders seems, of late, to have become a settled State policy. Thus, responsive to prejudice and pelf, your legislators have—may I say it?—become yearly more blind to the first principles controlling on the use of the roads. Some of these principles—trite, axiomatic, old-fashioned—I have already suggested. Let me emphasize them. For in the words of wise men, while "multitudes are ruled by prejudices," "principles, like troops of the line, are undisturbed and stand fast."

### The Camel and the Cart Ages.

When the two-wheeled cart first began to share with beasts of burden the wayward roads of prehistoric times, the camel age in transportation came to an end; the vehicle age clumsily began. The cart outstripped the camel; it needed more room. If we could but read the history of those times, the camel drivers were vociferous and vitriolic in their attitude toward the new invention, and, for a time, the carts were forced to lumber slowly over narrow and uneven paths. The years rolled on, the carts increased in number, the camels grew less, until, in the crowded ways of ancient days, the caravan gave place to a train of sturdy chariots; and the vehicle age, as we know it, had really begun. Now, I wonder how long did those ancients submit to the plaint of the camel man that he was frightened and crowded, and outstripped; how long did the chariot man submit to a rule of the road limiting him to camel speed? Doubtless, just so long as he could not help himself.

### The Motor Vehicle Age.

So of us. We live in the beginning of the motor-vehicle age. The day is dawning when the prehistoric beast of burden and the ancient cart will both all but vanish from the public roads. A mighty revolution in individual transportation is under way.

'Tis the camel-cart controversy over again. Like the camels, the carts are still much in the majority; there is clamor and complaint from their drivers; as of old, the roads are not altogether suited to new conditions; but, in the field of transportation, civilization has moved forward another notch, and there's no turning it back.

More in point, in this new era, these changed conditions, which is more sensible, more just, the enforcement of old customs or the adoption of new rules? Clearly, the latter. For a time, perhaps, the unrestrained use of the full powers of the new vehicle should be checked by positive law. This granted, as to speed at least, what should that law be? Unless I am much in error, a rational application of the simple maxim that, in the use of the public ways, the individual must so conduct himself as not to infringe the rights or endanger the life, limb or property of another.

Very true, admits the motor-phobe, but such a doctrine concedes the justice of present laws; your new vehicle constantly endangers the lives and property of others. I reply, does it do so on an open country road, visible for miles, without either a crossroad, another vehicle, an animal or a human being in sight? Does it even in the business streets of a great city, say, at dawn or at midnight? No; "miles-per-hour" is a statutory speed trap, where prejudice starts the stop-watch at one end, and legalized plunder bars the way at the other. The true principle, and, in road regulation, it is as old as the camel or the cart, is that unlawful speed should be determined, not arbitrarily by miles-per-hour, but, by the condition of the highway, and the traffic thereon at the time, that is, whether in the judgment of men the rate is such as then and there to endanger the lives or property of others.

#### Violations Fewer; Punishments Easier.

But, says the twentieth-century camel man, you would make it impossible to catch and punish. Not so. It would be easier far; that is, if all you want is to bring to book those who actually endanger the life, limb or property of another. The stop-watch would cease its wrangle with the speedometer; and the proof would be that of the ear and the eye of the spectator and of the principals. It would be easier to prosecute, not, as now, to persecute—surely, Mr. Modern Camelman, you wouldn't stand for that!—and not the least element making for conviction would be the general recognition of the justice of the rule, by the new charioteers.

And so I repeat, New Jersey has been blind to first principles, in enacting and enforcing a miles-per-hour rule. Connecticut was first to adopt the real rule. New York seems likely to do the same, this year. Why not New Jersey, too?

#### Whose Are the Public Roads?

Again, in this age of progress and enlightenment, whose are the public roads? The farmer's whose lands they abut, the town's in which they are, the commonwealth's through which they pass, or yours and mine, citizens of this nation of independent but indestructible States? In their beginnings, they were, perhaps, but cow-paths; in some cases, mere rights of way; in many instances, they are still imperfectly maintained by neighborhood labor; yet, in our modern civilization, they are and hereafter always must be the people's roads, free to all who come and go, whatever be their race, condition, or dwelling place.

If so, and the time has come—as it has—when the State must build and maintain them, it follows that they should be paid for by the State, and not by a part of the State, much less by any class of citizens of the State. Each of these principles is already violated all over the country; and, in the chaos of inequity in which our American tax laws have become involved, the injustice of the thing should, perhaps, for a time, be silently endured. Yet New Jersey, in enacting a registration toll from non-residents, and excusing it on the plea of road maintenance, stands almost alone.

#### Roads Should Fit the Traffic, Not the Traffic Fit the Roads.

But, says the road expert, your new vehicles destroy our fine roads. Perhaps; but, in an advancing civilization, roads should be made to fit the traffic, not the traffic to fit the roads. The Romans were the greatest of road builders. Little need had they for a wider surface or deeper foundation than would resist the progress of the legions and their camp equipment; yet, vast siege engines must also be transported, and so those roads were laid so deep that fifteen centuries of neglect have left them practically untouched. The great road builders of the new world, the Incas of Peru, to whom horses were unknown, found narrow ways, steps cut from mountain sides, and airy swinging bridges sufficient for their post runners; and a mighty, durable and substantial road system was that of barbaric Peru. But, the Spaniards came, with their horses and carts and, too shiftless to change the Inca roads to fit the traffic of a higher civilization, the highways, which once had done the work of a simpler people, went to ruin and decay. In all times and among all peoples, the strength of a public road, its success as a means of intercommunication, has depended—nay, must always depend—on its resistance to the wear, not of the foot passer, but of the harshest vehicle commonly used by its public. No; if these new macadam roads of ours are behind the times, in this, the motor vehicle age, they—not the times—must be changed; and, in changing them, right and justice suggest that the whole people, not a few, bear equally the burden.

#### Non-resident Road Taxation Indefensible.

But, again rejoin your road officials: You New Yorkers use our

roads; why shouldn't you help pay their up-keep? I might reply: You, New Jersey people, use our roads, and we haven't, save as reprisals, ever thought of asking you to contribute to their care. The real answer is again found in a resort to first principles. The fathers tried out the experiment of the loose Confederation, and quickly gave it up. By the Constitution, imposts and taxes between the States were prohibited, the regulation of commerce, intercourse and travel between them assumed by the central government, and the doctrine of commercial hospitality established as a principle of our land. There are no Chinese walls in our nation of States; no treaty ports need ever be established. This principle, one of wisdom, in that it makes for free trade between all of the States, and of comity, in that it establishes a neighborly hospitality nation-wide, is violated by New Jersey; and New Jersey suffers because of it. Thousands of motorists now shun your State, and your hotels, and your tradesmen are a million poorer each year.

#### \$10,000 of Tax or \$1,000,000 of Trade.

What's the matter with New Jersey?

Her legislators and her people are blind, not merely to interstate comity, but, for a few dollars of tax, annually sacrifice an hundred-fold more in trade, which now goes to States without walls. How far the principle of free travel should yield in cases where the outlander abuses his privilege by becoming an all-year or even a summer resident is an open question. But, to the mere tourist, the roads of New Jersey, like the sidewalks and pavements of Newark, should be as free as the New Jersey air.

#### Power-of-Attorney Clause Unwarranted, Un-American.

One more point, and I am done. Boston's protest against the tax on tea was the first drumbeat in a great struggle for liberty. I wonder how those sturdy Boston patriots would have borne a regulation of the English board of trade that, as a condition to trading in England, the colonial merchant must designate such board as his attorney to accept service in case of default or disagreement, and thus submit his rights to a hostile British jury, instead of one made up of his peers at home. Such a rule would have violated a principle more ancient than the doctrines for which Cromwell fought and Sam Adams thundered. Says Gibbon, speaking of the Salic law, which dates from the time of Clovis: "In all causes where the parties were of different nations, the plaintiff or accuser was obliged to follow the tribunal of the defendant." Such, in civil matters, at least, is the law of our land to-day. And yet, New Jersey, alone of all the States, says: Not so! On what theory? Are we motorists, in civil cases, criminals, too, whom, since under general law you cannot extradite, you would unrighteously force into the tribunal of the plaintiff? Or, are we merely undesirable citizens, against whom the power-of-attorney clause is intended as a bar? No, gentlemen; there are a few drops of New England blood still left in thousands of motoring men, who, if they but knew of this requirement, would not cross your borders in an automobile so long as that unwarranted and un-American provision is on your books.

#### Present Law Against Principle, Courtesy and Self-Interest.

What's the matter with Jersey justice? Blind, as justice should be! But, in dealing with the automobile, blind to the principles which should control the use of the public ways; blind, stone blind to that comitas gentium, or, in modern phrase, interstate courtesy, which our American citizenship expects and usually enjoys; blind—may I say it?—Chinese blind, to the interests, the pocket-books of her own people, in that, even in the year nineteen hundred and eight, the wall is still up and traffic and travel halted at her gates.

Men of New Jersey, forget what I have said that may seem harsh. Think only of the cause I represent.

Men of New Jersey, outside the wall we of other States extend the hand of good fellowship and bid you welcome everywhere.

See, the time has come. Won't you help throw down that wall?

The concluding speaker was Commissioner Smith, who told of the results secured by the present law, which he contended had been very satisfactory. An increase in the number of inspectors, he thought, would be of great worth.

President Angus Sinclair presided, and before introducing the first speaker, briefly reviewed the history of the club, told of its rapid growth, referred to its membership of nearly eight hundred, and paid a well-deserved compliment to H. A. Bonnell, the hard-working and conscientious secretary, who in the past year has done so much to further the prestige of the organization. Besides the orators of the occasion there were at the guests' table L. R. Speare, ex-president of the Bay State Automobile Association of Boston, and S. L. Haynes, ex-president of the Automobile Club of Springfield, Mass. Chairman Joseph H. Wood of the banquet committee had his troubles in providing for the large number of diners, not a few of whom were of the eleventh-hour variety.

## DIRECTORATE OF THE A. A. A. FOR THE YEAR IS ANNOUNCED

TWENTY-SIX States are represented on the board of directors of the American Automobile Association, and there are also spokesmen from the District of Columbia and the Hawaiian Islands. Before the end of the year it is expected that every State in the country will be represented on the governing board of the national automobile organization. Where a State association exists, that body selects the directors to the national board, and in States not yet organized, clubs belong direct to the A. A. A. and are given direct representation. Following is the list of directors:

<b>MASSACHUSETTS.</b> Elliott C. Lee, Lewis R. Speare, S. L. Haynes, W. H. Chase, John P. Coghlin.	<b>IOWA.</b> W. D. Petersen.	<b>VIRGINIA.</b> H. L. Myers.
<b>RHODE ISLAND.</b> Elliott Flint.	<b>KENTUCKY.</b> George H. Willson.	<b>MISSOURI.</b> Roy F. Britton, Harry M. Rubey.
<b>VERMONT.</b> W. H. Riddle.	<b>NEW JERSEY.</b> Joseph H. Wood, G. E. Farrington, George A. Post, J. H. Edwards, K. G. Roebbling, W. T. White.	<b>LOUISIANA.</b> Albert Mackie.
<b>CONNECTICUT.</b> W. F. Fuller.	<b>PENNSYLVANIA.</b> Isaac Starr, R. P. Hooper, Paul C. Wolff, Edward Kneeland, F. A. Godcharles, Peter A. Melzell, J. H. Weeks.	<b>TEXAS.</b> E. H. R. Greene, H. T. D. Willson, H. S. Crawford.
<b>NEW YORK.</b> Oliver A. Quayle, William H. Hotchkiss, Jefferson deM. Thompson, W. K. Vanderbilt, Jr., C. J. Edwards, F. B. Hower, Charles T. Terry, A. G. Batchelder, G. H. Stillwell, F. H. Elliott, H. S. Woodworth, C. H. Benedict, S. M. Butler, C. D. Hakes, Otis W. Sherman, A. R. Pardington.	<b>DELAWARE.</b> John Bancroft.	<b>WEST VIRGINIA.</b> W. E. Minghini.
	<b>MARYLAND.</b> Osborne I. Yellott, H. M. Rowe.	<b>GEORGIA.</b> F. C. Battey, H. J. Lamar, Jr.
	<b>DIST. OF COLUMBIA.</b> Horace C. Chandlee.	<b>FLORIDA.</b> Asa Paine.
		<b>OHIO.</b> F. T. Sholes, Windsor T. White, Val Duttonhofer, Jr.
		<b>MICHIGAN.</b> Edwin S. George, D. Emmett Welsh.

<b>INDIANA.</b> H. O. Smith, J. A. Speckenhier.	Charles P. Root, Sidney S. Gorham.	Oliver Crosby.
<b>ILLINOIS.</b> L. E. Myers, Ira M. Cobe, N. H. Van Sicklen,	<b>WISCONSIN.</b> James T. Drought.	<b>COLORADO.</b> F. L. Bartlett.
	<b>MINNESOTA.</b> Frank M. Joyce, Neal Brown,	<b>CALIFORNIA.</b> Milbank Johnson.
		<b>HAWAII.</b> G. P. Dennison.

The next meeting of the board of directors will be held at the association's headquarters Tuesday, March 3. Thereafter meetings of the board of directors and its executive committee will, so far as possible, be set for other cities, thus giving directors living at a distance from New York an opportunity to attend some of the meetings.

### Racing Board Appointments Announced.

The A. A. A. Racing Board, the appointment of which is just announced, is constructed on somewhat different lines than in previous years, the automobile manufacturing associations being given representation. It is considered that the time has come when racing matters should be directed, not entirely by amateur sportsmen appointed from the various clubs of the country, but also by manufacturers, and that with both elements represented on the racing board, much can be more effectively accomplished than heretofore. Following is the list:

Jefferson deMont Thompson, chairman, 26 W. 27th street, New York.	Frank G. Webb, vice-chairman, 105 Garfield place, Brooklyn, N. Y.	Frederick H. Elliott, secretary, 437 Fifth avenue, New York.	William K. Vanderbilt, Jr.,	A. B. Lambert,	Asa Paine,
Dave Hennen Morris,	Thomas Henderson,	Benjamin Briscoe, Jr.,	Thomas Henderson,	A. G. Batchelder,	A. G. Batchelder,
H. L. Bowden,	S. A. Miles,	Alfred Reeves,	H. L. Bowden,	H. A. M. Miles,	Lewis R. Speare,
George L. Weiss,	Percy Owen,	J. J. Mann,	George L. Weiss,	Harry W. Knights,	H. A. Bonnell,
Ira M. Cobe,	R. Lincoln Lippitt,	A. L. Riker,	Ira M. Cobe,	Rossiter Worthington,	Charles J. Swain,
R. Lincoln Lippitt,	A. R. Pardington,	E. R. Thomas,	R. Lincoln Lippitt,	H. H. Knowles,	Harry W. Knights,
A. R. Pardington,	H. H. Knowles,	Henry Ford,	A. R. Pardington,		C. G. Greenburg,
Rossiter Worthington,			Rossiter Worthington,		S. L. Haynes,
H. H. Knowles,			H. H. Knowles,		S. M. Butler.

## GOVERNOR TO ATTEND A. C. OF GERMANTOWN BANQUET

PHILADELPHIA, Feb. 12.—Governor Stuart is to be the star figure at the annual banquet of the Automobile Club of Germantown, to take place Saturday evening next at the organization's model clubhouse in Carpenter street, Germantown. Besides the governor, the notables will include Mayor Rayburn, Congressman Reuben O. Moon, Hon. Samuel P. Rotan, of Philadelphia; Charles W. Bosworth, of Springfield, Mass., and O. S. Henninger, of Allentown, Pa.

In view of the fact that the American Automobile Association secures the chairman of its Good Roads Board from

the Automobile Club of Germantown, in the person of Robert P. Hooper, the guests will include several prominent in the national organization: Isaac Starr, president of the Pennsylvania Motor Federation; A. N. Chandler, president of the Automobile Club of Philadelphia; Charles Thaddeus Terry, chairman of the A. A. A. Legislative Board; Frederick H. Elliott, secretary of the A. A. A.; and A. G. Batchelder, chairman of the Publications Board. It is anticipated that the affair will be the most successful in the history of the club, and the main banquet hall will be filled to overflowing.

## TAXING THE AUTOIST TO KEEP JERSEY ROADS IN REPAIR

ONE of the most influential newspapers in the entire country is the New York Times. Once, before its owner became an autoist and personally acquainted with the experiences of other autoists, there were occasional editorials in that daily which failed to find much approval from those interested in the motor-driven vehicle. But the Times saw the handwriting on the wall, as is evident from the following editorial, entitled "Taxation Has Its Perils":

Gov. Fort of New Jersey, it is reported, thinks that automobilists should be made to pay enough in the shape of licensing fees to keep in good order the main roads of the State, and, with that pious end in view, he is having prepared for submission to the Legislature laws which will much increase the special burdens of the motor car folk, particularly those from other States.

It seems to us that Gov. Fort would do well to go rather slowly in this direction and to think things over several times before he goes far. Of course, the automobilists ought to contribute for the up-keep of roads. Nobody doubts, nowadays, that the machines

inflat no little wear on highway surfaces as at present constructed, distributing the same in the shape of dust over the circumjacent landscape, but while it is right for the automobilists to pay their way, it is not obviously just to impose on them anything like the entire cost of maintaining the roads they use, and to do so might easily be the reverse of good economics.

The automobilists, Gov. Fort and other Jersey men should remember, have a habit of spending money as they move along over the earth's surface—of spending it at frequent intervals and in quantities highly satisfactory, at least to the recipients. And the recipients are many. Not only innkeepers and the owners of repair shops and garages profit by the opportunity to satisfy the ever-recurring needs of these travelers, but almost everybody else, in one way or another, directly or indirectly, comes in for a share from these expenditures.

A certain amount of taxation this form of traffic will bear without effective resentment, and that amount, or something close to it, can safely be imposed, but to exceed it is to decrease, not increase, the revenue, for the effect will be to make the automobilists seek other scenes, where, if they are not better loved, they are at any rate better appreciated.



## WINTER ACTIVITIES OF THE AUTO CLUBS

### RULES FOR BAY STATE FEBRUARY 22 RUN.

BOSTON, Feb. 10.—Rules to govern the 150 miles endurance run that is to be conducted by the Bay State Automobile Association on Washington's Birthday, February 22, have been issued by the committee in charge. In making up the rules the committee has had before it the rules which gave much satisfaction in the Boston to Keene, N. H., endurance run last summer, and also the rules of contests elsewhere, such as the Chicago and Quaker City runs, and it has evolved a set of regulations which it claims are the most concise and complete of any yet used in such an event. There will be a contest committee having charge of the cars while on the road, and also a technical committee which will make the examination of the machines at the end of the run. The two committees, however, will work independently, and it is not intended to permit complications to arise by making the findings of the technical committee subject to review by the contest committee.

The run will start at the Bay State Association's clubhouse on Dartmouth street, Boston, at 7 o'clock on the morning of the holiday, and controls and time schedules will be established throughout the route. The first leg of the run will be to Providence, where there may be a short stop for luncheon. The second leg will be from Providence to Worcester, where there will be another short stop, and the final leg will be from Worcester to Boston. The roads selected are the best available, being mostly State highways of macadam construction, which are usually in good condition no matter what the weather may be. The time schedule will be within the State law and local ordinances and special rules have been made to prevent racing between controls.

There are to be two classes: Class A for touring cars and four-seated tourabouts, and Class B for two or three-seated runabouts. A silver trophy will be awarded the winning car. In case of tie the committee may require that the contest be continued, or certificates will be awarded to the winning cars. All cars must be of stock patterns and carry regular equipment. Observers are to be carried, and in addition there will be checkers at the various controls. The penalties will be two points a minute for adjustments, repairs and replacements, one point a minute for being late at controls, two points a minute for being early at controls and five points for not keeping the engine going except at certain specified points. Entries will close with Alfred N. Robbins, secretary of the committee, 53 Stanhope street, Boston, at 6 P.M., Wednesday, February 19. The committee in charge consists of J. C. Kerrison, Ernest A. Gilmore, Horace G. Kemp and Alfred N. Robbins.

### AUTOISTS DINE ROAD SUPERVISORS.

NEWCASTLE, PA., Feb. 10.—The newly formed Automobile Club of Lawrence County entertained the county supervisors at luncheon at Fountain Inn, February 5, the occasion being the meeting of the supervisors to formulate plans for the betterment of the country roads. The meeting was addressed by State Highway Commissioner Joseph W. Hunter and others prominent in road improvement circles. So far there has been about twelve miles of macadam road constructed under the new Pennsylvania law, but owing to the top layer being half clay the roads already need repairs costing \$400 to \$700 per mile. All the supervisors are in favor of a fourteen to eighteen-foot roadway of vitrified brick, as the first cost is but little more than macadam, and the repairs would be practically nothing, while such a road would also be practically free from the nuisance of dust and mud.

### QUAKER CITY CLUB ELECTS NEW OFFICERS.

PHILADELPHIA, Feb. 10.—The principal business transacted at the annual meeting of the Quaker City Motor Club at the Hotel Majestic, last Thursday night, was the election of officers to serve during the ensuing year. The only contests were for secretary and the board of governors. The election resulted as follows: President, P. Donald Folwell; first vice-president, A. T. James; second vice-president, L. D. Berger; treasurer, A. T. Stewart; secretary, Harry C. Harback; the foregoing and Charles J. Swain, G. Douglass Bartlett, Frank Hardart, E. H. Lewis, Richard Sellers, Dr. J. R. Overpeck, G. Hilton Gantert, M. E. Brigham, and W. J. Donnelly constituting the new board of governors.

Previous to the election the prizes won in the club's New Year's endurance run were presented—Class A to George H. Smith (White); Class B to J. D. Dorrance (Packard); Class C to W. M. David (Maxwell); and Class D to Daniel Webster (Frayer-Miller). The winning drivers in Classes A, B and C were awarded solid gold watch fobs designed after the club's emblem. Certificates of merit were also awarded the three clean-score Class A cars in the original run on January 1-2 of the present year.

A banquet followed, during which many prominent officials of the club responded to impromptu toasts. Ex-President Swain sounded the keynote of the club's policy when he urged a continuance of the past activity in the promotion of road competitions of various kinds. In his opinion such events have a marked beneficial effect in sustaining interest in the club and its work. One of his suggestions—the amendment of the by-laws to include a Technical Committee in the official list to be named annually by the president—was well received, and may be acted upon later.

The first official act of President Folwell after his induction was the naming of Richard Sellers, a member of the board of governors and a prominent local engineer, as chairman of the contest committee. This selection insures another active year for the club. The preliminary outline for the coming campaign, which will include Spring and Fall race meets, a hill climb, the New Year's endurance run, and other events, was discussed by Mr. Sellers, although he has not as yet decided upon the personnel of his committee.

### "LAND'S END TO LAND'S END" ECONOMY RUN.

BROOKLYN, N. Y., Feb. 10.—Entry blanks for the first annual midwinter Land's End to Land's End economy test, to occur Tuesday, February 25, under the auspices of the Long Island Automobile Club, have been issued. The course is from the clubhouse at 360 Cumberland street, Brooklyn, to Montauk Point and return, a distance of 242 miles in one day. Under the conditions named by the contest committee, the route to Babylon is elective. From Babylon to Montauk Point cars will follow the Merrick or South Country Road to Patchogue. From Patchogue the route leads to Southampton and from there to the lighthouse at Montauk Point.

On the outward trip there will be four checking stations, the first at the Sherman House, Babylon; the second at Roe's Hotel, Patchogue; the third at the Irving House, Southampton, and the fourth at the lighthouse at Montauk Point. The route for the return trip is elective and there will be no checking done except at the finish at the clubhouse.

The start will be made at the clubhouse at 6 A. M. No cars will be checked in at night before 9 o'clock P. M. and none after 12 o'clock midnight. First prize in the hard contest, valued at \$200, will go to the car which carries its full quota of passengers the entire distance at the least per capita cost.

## N. A. A. M. FIXES EXACT DATES FOR CHICAGO SHOW

FEBRUARY 6 to 13, inclusive, has been fixed upon as the exact time of the next Chicago show, to be held in the Coliseum and First Regiment Armory, this decision being arrived at at a meeting of the executive committee of the National Association of Automobile Manufacturers held in the New York offices, February 5. The question of a commercial vehicle department remained undecided, but it was resolved to make some changes in the rules covering allotments in order that the distribution of space may, if possible, be more equitable. No definite action on this will be taken for some time, however.

It was decided to organize a traffic department, of which J. S. Marvin, until now associated with a similar branch of the Association of Licensed Automobile Manufacturers, will in all probability be in charge. F. H. Hart, representing the Corbin Motor Vehicle Corporation, was elected to membership, and Messrs. H. O. Smith, of the Premier Manufacturing Company, and Angus Smith, of the Olds Motor Works, were elected members of the executive committee, replacing G. W. Bennett, who formerly represented the Knox Company, and M. L. Goss, deceased.

In connection with the informal discussion on the outlook, Manager S. A. Miles declared: "My personal opinion is that the recent difficulties will prove to have been a godsend to the industry. There can be no doubt that we were on the eve of a tremendous over-production, which has been headed off—first, by the determination of wise makers to curtail

production, and second, by the inability of the unwise ones and the experimenters to procure the necessary capital to enable them to flood the market. It is not unlikely, I should say, that even the most radical men must become convinced of the folly of producing cars without some reasonable certainty that they will sell; in other words, that practically all makers will, in the future, be reasonably sure of their market before they incur the expense of manufacture."

### Brock Resigns Position with Licensed Body.

At the meeting of the executive committee of the Association of Licensed Manufacturers held the same day in their offices, on East Forty-second street, the resignation of Marcus L. Brock as associate manager was received and accepted with regret. In consequence of this resignation the transfer of the traffic department to the N. A. A. M., and other changes, there will be some rearrangement in the staff of the licensed body, as a result of which it is understood that H. T. Clinton will look after the agency interests and to some extent the traffic affairs, as well as have charge of the advertising department. M. J. Budlong, the general manager, will take over most of the duties which fell to Mr. Brock.

Among those who attended either one or both of the meetings were Charles Clifton (Pierce), Thomas Henderson (Winton), S. T. Davis (Locomobile), W. E. Metzger (Cadillac), Herbert Lloyd (Columbia), F. L. Smith (Oldsmobile) and L. H. Kittredge (Peerless).

## 'FRISCO TO HAVE A SHOW, WOMAN'S CLUB ASSISTING

SAN FRANCISCO, Feb. 8.—The automobile enthusiasts of this city are not going to allow 1908 to pass without holding an automobile show. Unlike last year, it will not be given by the Dealers' Association, but has been started by those of the dealers who voted in minority when it was decided not to hold a show this year. The dealers are the ones who handle cheaper cars, that are sold out in the suburbs and the smaller towns. The representatives of these cars have from the very first wanted the show, and a number of them came together and decided to hold the event March 2-8. The patronage was offered the California Woman's Automobile Club. This organization has been most progressive of late, and accepted the offer with enthusiasm, as all the profits will go into their treasury. There is likely to be a little friction between those who want the show and those who do not. Already the officers of the club have canvassed the "Row" and have most flattering signed agreements. It is proposed to open the show with a big night parade, ending at the Coliseum, where the formal opening will take place.

Edwin L. Thomas, vice-president of the E. R. Thomas Motor Car Company, has arrived and is making his headquarters with the Pioneer Auto Company. Mr. Thomas will look over the automobile field, and especially that part which interests his company, concerning the taxicabs, which are likely to be put into service in this city shortly.

Paul Lacroix is in San Francisco, where he has established a western branch of the Renault Freres Selling Branch. R. J. Marx is to be manager.

Fernando Nelson, the enthusiastic autoist of this city, has again come to the front with what bids fair to break the record of unique suggestions for the entertainment of the officers and men of the fleet of warships soon to arrive in our harbor. He has proposed that every owner of an automobile shall loan his car for one day, and a line of march so arranged that it will reach all points of interest, and give the best views of the Bay and Presidio, be planned for the entertainment of these guests. The automobiles will be artistically decorated in the national colors.

## INDIANAPOLIS SHOW DATES SET FOR MARCH 16 TO 21

INDIANAPOLIS, IND., Feb. 11.—Makers and local dealers have taken preliminary steps for the holding of the Indianapolis annual show, March 16-21. No building in the city being large enough to contain all the cars, the various dealers will have shows in their garages, assisted by men from the factories. Suggestions put forth for the event are that as an opening attraction a parade should be held on the afternoon of March 16 and that all automobile owners in the State be invited to participate. A local newspaper has offered a prize to the city or club having the largest number of automobiles

in line. There will also be a hill-climbing contest, probably at Glenn's Valley, and an obstacle race in the city. A banquet on the evening of March 21 will close the show.

A. E. Vinton, of the G & J Tire Company, has been appointed chairman of the temporary organization which will have the program in charge; P. D. Stubbs, representative of the American Motor Car Sales Company, has been appointed secretary, and R. H. Losey, of the Buick-Losey Company, is treasurer. Committees have been formed to look after the various parts of the program.

## DIEPPE CIRCUIT AGAIN CHOSEN FOR GRAND PRIX

PARIS, Feb. 4.—Dieppe, which in 1907 was the scene of the highest rate of prolonged travel ever witnessed on road, will next July witness the third annual Grand Prix of the Automobile Club of France. The 48-mile triangle, with Dieppe at its northwest corner, has been a strong favorite since last year. Dieppe is near Paris; it is close to England; it is in the midst of a holiday resort district; it can attract and accommodate thousands of spectators; it can raise a substantial subvention—in brief, it makes the financial success of the race an absolute certainty; and, as the Racing Board of the A. C. F. is no longer indifferent to monetary matters, the Normandy circuit has triumphed. The question of roads hardly entered into consideration. There are a score of districts in France that could offer just as good a set of highways for racing purposes, but probably not one that could present such all-round advantages.

Ten thousand dollars in cash will be handed over by the Dieppe authorities for the privilege of having the race in their district. Further, the same authorities undertake to put the 48 miles of road in perfect condition at an expenditure of probably \$6,000. In no other country in the world have the rural populations been educated to a point where they would receive an automobile race with such enthusiasm or make such material offers to obtain it. One little village on the course, too small to entertain visitors, and destined, in consequence, to receive nothing but noise and inconvenience from the race, threatened for a time to act in a dog-in-the-manger spirit. Before the government will grant permission for any road race it is necessary that the consent of every village or hamlet on the course should have been obtained, so that it is always possible for a handful of men, if they desire to be stubborn, to hold up an event ardently desired by a whole département.

The grandstands, which last year were on a straight stretch of road parallel with the sea, will be erected on a portion of the road between Dieppe and Envermeu, and not more than eight hundred yards from the difficult Dieppe fork turn. Thirty-two acres of land have been secured at this point, at a rental of \$2,600, and it is on the inside of the circuit that immense grandstands, offices, restaurant, and the usual paraphernalia of a big road race will be erected. To enable visitors to leave the stands at any time during the race a spacious tunnel will be constructed under the road.

In all probability July 7 will be selected as the date of the Voiturette Grand Prix and July 8 for the powerful machines running under the 155-millimeter international racing rule. The Racing Board has taken the wise decision to cut down the entrance fee for the voiturette race by nearly one-half. Originally fixed at \$200 for a single car, it is now \$100 for a single entry, \$180 for a team of two and \$240 for a full team of three. The original entrance fee of \$400 was almost the market value of some of the small cars and threatened to drive away the small firms interested in the 15-horsepower runabouts. Under the new rules it is certain that there will be a record entry of small racers, and probably a race as keenly contested as the speedier one among the powerful flyers. Entry fees for the Grand Prix have undergone no modification. Twelve cars are now officially entered for the Grand Prix, the firms represented, each with full teams, being Germain, Benz, Fiat and Panhard & Levassor. Now that the course has been chosen, the twelve or fourteen firms known to be building racers will no longer keep back their entries. Last date for receiving engagements at ordinary fees is February 15. For the voiturette race Isotta-Fraschini is the only entrant at present, with three small four-cylinder cars. It is expected, however, that the entries will not be less than forty.

### PREPARATIONS IN FULL SWING FOR SAVANNAH.

With seven actual entries and assurance from thirteen other firms that they will participate in the 360-mile stock chassis race, the Savannah meet, March 18 and 19, is assured of success. The engagements include two Apperson "Jack-rabbits," two Thomas-Detroit, two Isotta, and one Premier. Those having promised entries are Stearns, Stevens-Duryea, National, Mora, Studebaker, Dragon, York Pullman, Pennsylvania, Stoddard-Dayton, Fiat, Chadwick, Maja and Acme.

### CHRISTIE WILL MEET THE FIAT AT ORMOND.

Walter Christie has taken up the challenge to race the Fiat *Cyclone*, a lightweight flyer recently imported, in a 100-mile match at Ormond in March. Christie, in sending his check for \$500 to Chairman Robert Lee Morrell, stipulates that the race be thrown open to all comers and be made a sweep-stake event, to which the challenger has consented. Christie has named the 130-horsepower direct drive car built for and entered in the Grand Prix last year.

## HISTORY OF A RACER WHICH NEVER RACED

A RACING automobile which never raced has brought Alfred G. Vanderbilt, its owner, and François Richard, its builder, into a legal squabble over the payment of \$5,000 demanded by the latter.

In October, 1905, when preparations were active for the Florida tournament of the following January, Mr. Vanderbilt was introduced, through his chauffeur, Paul Sartori, to François Richard, said to be skilled in building racing cars. Order was given to go ahead on the construction of a 250-horsepower eight-cylinder racer to be the fastest car the world had ever seen. Three months was a short time in which to produce such a machine, but by working day and night, and engaging a special train at the last moment, the monster was on the Ormond-Daytona beach in time.

Unfortunately for the plans of the speed annihilators, the eight huge cylinders failed to give forth more than spasmodic explosions. A small army of mechanics wrestled with

it in the Hotel Ormond garage, while Alfred G. Vanderbilt looked on with ebbing enthusiasm. Finally the 250-horsepower 100-mile-an-hour flyer was shipped back to New York, carried to the garage, and left there. Mr. Vanderbilt was reported to have expended \$20,000 in his vain attempt to create a speed record. Later a bill for \$5,000 was received from M. Richard for three months' work on the car. Mr. Vanderbilt refused to pay on the ground that the car was a failure. The designer urged that the work was all that could have been expected, and that the car would have run had there been time to put it into condition.

In the Supreme Court, before Judge Girard, Thomas J. Fay, automobile expert for Mr. Vanderbilt, testified that if the car ran at all it would go twice as fast as the designer intended it to do, and instead of 250 horsepower, it would require 1,000 horsepower. The court found for M. Richard, enjoining the defendant to pay over the sum of \$1,250.



SUCCESSFUL H. H. FRANKLIN CO. SHOW IN SYRACUSE, N. Y.

### MEASURE EXCELLENT; PASSAGE DOUBTFUL.

ALBANY, N. Y., Feb. 10.—In the bill of Assemblyman Wainwright, recently introduced, motor-vehicle owners get what they have claimed should be the law regarding the carrying of lights at night by horse-drawn vehicles on the country roads. Mr. Wainwright's bill provides that a new subdivision shall be added to the county law which shall empower supervisors of any county "to make laws requiring vehicles on the highway in the county to carry a light at night, and prescribing the character of such light. But such law shall not apply to vehicles required by any other law or ordinance to carry a light at night."

### THAT BUFFALO-NIAGARA FALLS BOULEVARD.

BUFFALO, Feb. 10.—Announcement is made by the management of the automobile show that one day's receipts will be set aside in the hope of creating a substantial fund to be used in the promotion of the scheme to construct a boulevard from Buffalo to Niagara Falls. The plan has received the approval of local automobilists, according to Secretary D. H. Lewis, who says that members of the Automobile Club and representatives of the automobile trade are enthusiastic about it. Mr. Lewis announces that Thursday, March 12, will be known as Boulevard Day, and the admission price will be one dollar. All the money taken in at the door on that day will go towards the boulevard fund. Souvenir buttons will be issued and it is proposed to advertise the day extensively.

### AEROPLANES FOR ARMY.

Three aeroplanes instead of one are to be built for the Signal Corps of the army, as a result of a decision taken by the Board of Ordnance and Fortifications, and approved by Secretary Taft. The three flying machines have been selected out of 41 bids made to the service, the successful ones being Wright Brothers, of Dayton, O., \$25,000, delivery in 200 days; A. M. Herring, New York City, \$20,000, delivery in 180 days; J. F. Scott, Chicago, \$1,000, delivery in 185 days. The funds at the disposition of the board only reach \$25,000, but it is believed that the balance will be voted by Congress during its present session in order to cover the cost of the other machines.

### PROSPECTS BRIGHT FOR NEWARK SHOW.

NEWARK, N. J., Feb. 10.—Instead of finding difficulty in promoting an automobile show in this city, officials of the New Jersey Automobile and Motor Club and the New Jersey Automobile Trade Association now find that they could have easily filled a larger hall than that at Electric Park, which the show will occupy from February 21 to 29. Decorators have been at work on the interior and the other preparations for the opening of the show have progressed so favorably that there is little doubt of everything being in place on the minute when the doors are thrown open. Horace A. Bonnell, secretary of the club, has already received the consignment of flags ordered for publicity purposes. They bear the inscription "Auto Show, Electric Park, February 21-29." These pennants will be distributed to dealers and club members and will temporarily supplant the familiar blue and gold club pennants. It is anticipated that next year will see an automobile show in the First Regiment Armory, or in the new Essex Troop's home, now in course of construction.

### C. R. MABLEY RESIGNS AS SALON MANAGER.

At the meeting of the Importers' Automobile Salon, which was held at its offices in the Bryant Park Building, New York City, last Thursday, the resignation of C. R. Mabley as general manager, which was handed in the month previous, was accepted, and Mr. Mabley was given a unanimous vote of thanks for his good work on behalf of the organization during his term in office. W. R. Lee, who acted as Mr. Mabley's chief assistant, was appointed manager. It has been decided to combine the headquarters of the Importers' Salon with those of the New York Automobile Trade Association in the offices of the former in the Bryant Park Building, a very satisfactory arrangement having been effected between the two associations for the occupation of the same offices.

### PROGRESS OF THE "MUDLARK" SOUTHWARD.

NASHVILLE, TENN., Feb. 10.—For the past 500 miles, Ralph Owen, who is driving the 40-horsepower Oldsmobile from New York to New Orleans, has found the going particularly strenuous owing to the January thaws and washouts, this city being reached 30 hours behind the prearranged schedule. On this account Chattanooga will be omitted from the route, the *Mudlark* having left here last Friday bound for Birmingham, Ala. Owen expects to be in New Orleans February 14, if the time lost can be made up. After the Mardi Gras, the party expects to take the car to Cuba for an island trip.

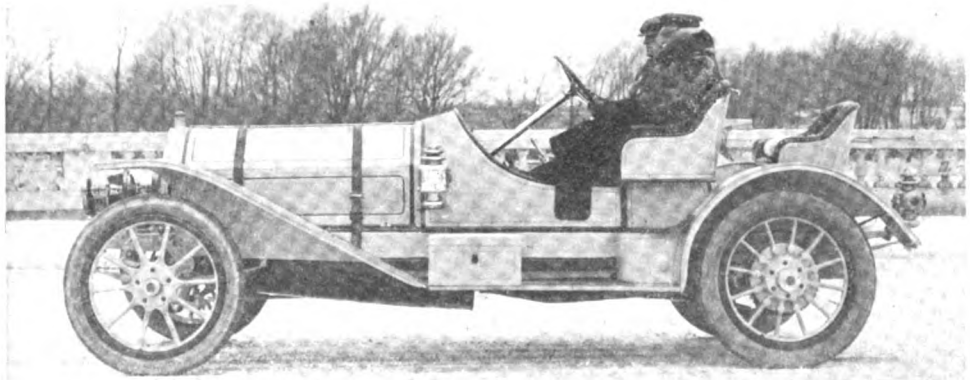

E. R. THOMAS TAKES A RIDE IN THE NEW SIX-CYLINDER RUNABOUT BEARING HIS NAME



## BRIEF ITEMS OF NEWS AND TRADE MISCELLANY

The two shaft-driven Lozier cars which Michener and Mulford will drive in the Briarcliff Trophy race, will each be four-cylinder models of 45-horsepower. In our last week's issue their rating was incorrectly given as 50-horsepower, thus giving the impression that the six-cylinder models had been entered.

According to figures received by the American Motor Car Manufacturers' Association, the American exports of automobiles during 1907 total 2,894, with a value of \$5,120,963, as compared with a total of 1,155 cars of a value of \$1,792,308 during 1906. This represents a gain of 1,730 complete cars with an aggregate value of \$3,328,655.

Carpet cleaning by automobile power is a familiar sight in San Francisco, and the patrons of the new system declare it a thorough success. The Le Clair Company, which is responsible for the innovation, owns a 1904 two-cylinder Winton, which carries a vacuum pump back of the driver's seat. When the car reaches the customer's house, a hose is extended from the pump to the house, and the power of the motor is used to drive the pump.

The Hicks Speed Indicator Company, of 1263 Atlantic avenue, Brooklyn, has just been reorganized, Carl Knopf, the president of the new company, being the only one of the old firm to retain his connection with it, although C. B. Sterling continues as sales manager. New capital as well as new blood has been infused into the concern, which has been reorganized on a larger scale than formerly. The officers are Carl Knopf, president; H. K. Carr, secretary and treasurer.

"Dealers in the West feel that conditions are improving rapidly and are much encouraged," says F. R. Bump, sales manager of the H. H. Franklin Manufacturing Company, of Syracuse, N. Y. "The banks have begun to supply all the money that is needed, and as a result quite a number of orders have been placed with us for immediate or early spring delivery. There is apparent a sentiment that the season will be a good one and that it will start with a rush before long."

Being desirous of placing their composite road wheels on the American market, the Atlas Motor and Engineering Company, of Levenshulme, Manchester, England, is open to enter into communication with any firm prepared to take up the manufacture and sale of its products. The wheels, which are patented in the United States and elsewhere, are a composite of steel and wood, and are built in various types for automobiles, commercial vehicles, omnibuses and horse-drawn vehicles.

Mule trails in the Southern California Sierras, over which an automobile had never passed before, were recently negotiated by a 1907 16-horsepower Model G Franklin in a break-neck trip from Los Angeles to the mines in the east of San Diego County. During the last twelve miles, an ascent of 5,000 feet, over twisting trails, was made by the dim light of oil burners, the acetylene lamps having given out. Mills Titus of Los Angeles, accompanied by three other men, drove the machine.

That the American "invasion" of Europe is not confined to automobiles alone, but

also includes accessories, and that even the crowned heads of the Continent are succumbing to this invasion is proved by a sale recently made by S. F. Bowser & Company, of Fort Wayne, Ind. This company had previously made several sales of their "long-distance" gasoline storage outfits in Dresden, and it is evident that their merits have been recognized, for recently an order was received from the King of Saxony for a five-barrel equipment.

E. V. Hartford, president of the Hartford Suspension Company, who is an accomplished musician, suffered an irreparable loss in the disappearance of two valuable old violins from the trap of his limousine, when returning from Lakewood, N. J., on Monday last. Mr. Hartford makes a practice of taking his violins along with him on pleasure trips, and the last thing known of the case containing them was the fact that it was placed on the trap of the car when leaving Lakewood. The jolting must have knocked it off. In describing his loss Mr. Hartford says that it is impossible to place a value on the violins, and he has placarded the roads, offering a liberal reward.

This is the time of year when the average owner of a car begins to look it over with a view to making such repairs as are necessary for the coming season. One of the most annoying troubles usually found on a car left unattended for several months is the cracking of the top or side curtains. Heretofore repairs have been made by patching, but a Saugerties (N. Y.) firm, the Montgomery-Washburn Company, has just placed on the market a waterproof compound, with the aid of which all cracks and leaks may be repaired without showing the repair itself on the surface of the material. Its composition is the same as that largely used by these makers for the waterproofing of tarpaulins, aprons and wagon covers.

"The new policy lately inaugurated by our company of opening branch houses in many of the larger cities instead of marketing our cars through local agents, seems to be meeting with great favor among car owners," says Colonel George M. Studebaker. In addition to our branches which have been established for a number of years, in the last few months we have opened new branch houses in Philadelphia, Boston, Cleveland and Seattle, and will soon open other branches at principal points not already covered, and we expect to handle our cars through these branches as long as our company is in existence. The purchaser of a Studebaker car in any of these cities is assured of good treatment as long as his car remains in commission, and that we will protect and further his interests in every way possible."

### NEW AGENCIES ESTABLISHED.

The Post & Lester Company, Hartford, Conn., will open a branch retail store at Hartford, opposite the Allyn Hotel, about March 1.

Philadelphia's South Broad street colony was still further reinforced last week, when the Kissel-Kar was installed in a home of its own at No. 729. It will have the Dorris car as an agency mate.

Among the recent agencies established by the Northern Motor Car Company, Detroit

and Port Huron, Mich., to handle the "Silent Northern" for 1908, are the Hutchinson Motor Car Company, Hutchinson, Kan., and James F. Hutchinson, Jr., Union, Ore.

Charles E. Miller has just moved his Cleveland branch house from 406 Erie street to 1829 Euclid avenue, which now gives him a location in the heart of Cleveland's automobile district. A recently added branch house is located at 1392 Bedford avenue, Brooklyn, while others are established in Buffalo, Philadelphia, Boston and Detroit.

The Philadelphia agency of the Thomas car has changed hands, Joe Keir succeeding the Harry S. Houpt Company. Mr. Keir, who handled the Renault in the Quaker City for about a year, and a month or more ago assumed the management of the Bergdoll Motor Car Company, will take hold of the Thomas at once. The present quarters of the agency at 139-141 South Broad street, will be retained.

### PERSONAL TRADE MENTION.

Rossell Drisko, well known throughout New England automobile circles, has accepted the position as general manager of Grout Bros. Automobile Company, Orange, Mass.

In Frank A. Sanford, the newly appointed Wayne agent for Greater New York, who has opened headquarters at 1853 Broadway, Barney F. Everitt, president of the Wayne Motor Car Company, Detroit, Mich., thinks he has the "right man" for the place. Mr. Sanford has been actively connected with the industry for several years past and is a staunch believer in the Wayne car. "The Wayne proposition from the start has impressed me most favorably from a pronounced desire on the part of the factory to produce a good article and then stand back of it in every sense of the word," he said, in speaking of the car. "I believe that the Wayne '30' at \$2,500, with magneto equipment, is as good a car as can be found on the American market to-day."

### GEO. N. PIERCE'S RETIREMENT.

As a result of the reorganization of the George N. Pierce Company, Buffalo, N. Y., makers of the Pierce Great Arrow cars. George N. Pierce, the founder of the business, has retired from active participation in the company's affairs. He is succeeded by George K. Birge as president, the other officers being Henry May, vice-president; Charles Clifton, treasurer, and L. H. Gardner, secretary. The directors are George K. Birge, Henry May, Charles Clifton, W. H. Gardner and William B. Hoyt. With the exception of Mr. Pierce's retirement and Mr. Hoyt's accession to the board of directors, this is the same organization that has been in control of the company during the past ten years, during which period Mr. Hoyt has acted as counsel. Mr. Pierce has disposed of all his holdings in the company to his associates in order to relieve himself of the cares of active business, a step largely brought about by the ill-health of Mrs. Pierce, with whom he will go south for the winter. There will be no change in the active working forces of the company and no change in the well-defined policy long adhered to by Mr. Pierce as its head.

**INFORMATION FOR AUTO USERS**

**Mascot Auto Clock.**—A timepiece is one of the things that will probably never disappear from the dash of a car no matter how free the latter may become from other impediments, such as coils and oilers. It is as much of a necessity as the speedometer, and, realizing this, the Angier Company, 735 Boylston street, Boston, Mass., have brought out a neat, reliable offset dash clock at a price within the reach of



MASCOT AUTO CLOCK AND MOUNTING.

the man who can only boast the ownership of the lowest-priced runabout. It has been appropriately named the "Mascot," and consists of an Ingersoll, 24-hour stem-wind and stem-setting movement in a heavy, polished brass mounting, as shown by the accompanying illustration. It sells for \$4 complete and will make an attractive ornament for the dash of any car.

**Almy Spark Timers.**—As will be evident from the accompanying illustration of this device, it is of the platinum-contact type, the springs operated by the specially shaped cam being held at one end. It is designed to give positive and accurate timing on a four-cylinder engine, and by the use

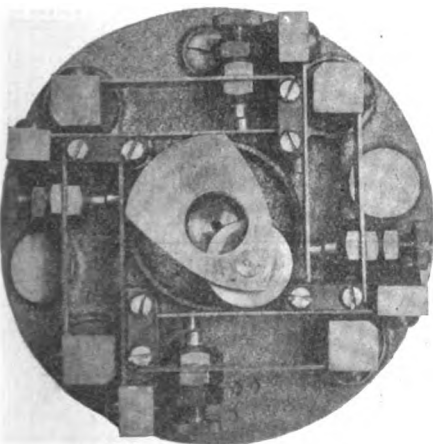

MECHANISM OF ALMY TIMER.

of a double spring and cam the advantage of a wiping motion is gained at every revolution or lift of the cam wheel. This makes perfect electrical contact, keeps the contact points clean and prevents them from pitting. The Almy timer consists of a bronze base, in which is located either a plain or ball-bearing, a camshaft containing the roller to lift the springs and a set screw to fasten the device to the timer

shaft. The four double sets of springs are also mounted on this base and are enclosed by a protecting cover. The bronze base is so arranged that the springs are fastened to its face by posts, the upper posts being

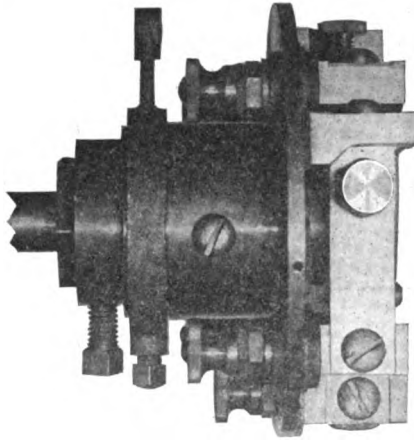

SIDE VIEW ALMY TIMER.

insulated and extending through the back to form terminal connections for the wires. The ground connection is also fastened to the back. The advance lever is arranged to set at any point of the circle and is located at the extreme back of the timer. The lower springs are also fastened by posts and form the ground side of the contact, only the upper springs being adjusted, this being effected by merely slacking the lock nut and turning the adjusting screw up or down. By this means each cylinder of the engine can be made to fire at exactly the same point on the stroke. The Almy Timer, which is covered by a patent, is being manufactured and marketed by the Almy Water Tube Boiler Company, Providence, R. I.

**The Combat Igniter.**—"To get an efficient spark from a storage battery it must possess volume (amperage) and pressure (voltage) sufficient to make a quick, hot spark," say the makers of the Combat Igniter, the Commercial Battery Company, 204-206 Michigan street, Chicago, Ill. But there are quite a few other things essential in an accumulator

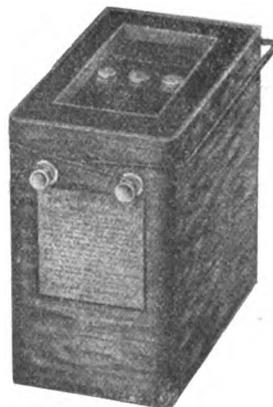

COMBAT IGNITER (STORAGE BATTERY).

for automobile ignition that will render satisfactory service, and, while the chemist must do his work properly, it will avail little on a car unless adequately housed. Particular attention has been

paid to the design of the Combat Igniters on this score, so that the makers guarantee the active material not to fall out of the grids, while their patented one-piece hard rubber cover prevents any of the liquid from getting out except through the vent plug for the gas, and then only when turned upside down. The central portion of this cover is so constructed as to form a well, thus holding any liquid that may get on top of the cell when replenishing the electrolyte or in recharging. Another feature of merit is a detachable japanned handle which drops to either side and may readily be put on or removed, no exposed metal being employed where it will come in contact with acid fumes. The Combat Igniter is made in two styles, one with hard rubber cases ranging from 4 volt, 10 ampere hour size up to 6 volt, 40 ampere hour size, and in polished oak cases from 6 volts, 40 ampere hours to 8 volts and 120 ampere hours. The same makers also market the Combat-Magneto-Generator-Cut-Off, which consists of one of their Combat Igniters with a small generator and an automatic cut-off, thus comprising a complete and self-contained ignition system.

**The Telltale Tail Lamp.**—Regardless of how they may differ on other points, the automobile laws in this country are uniform in the requirement of a tail lamp

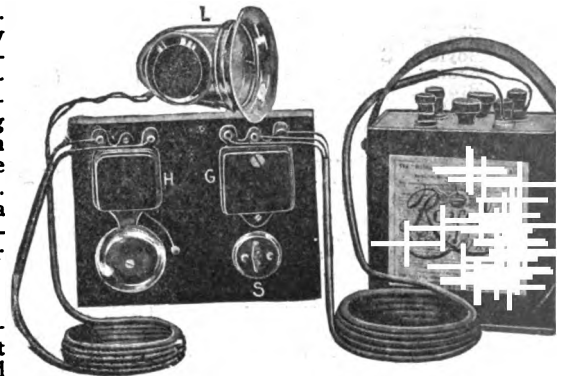

TELLTALE TAIL LAMP AND BATTERY.

that shall light up the license number and show a red light to the rear. The law is not rigidly enforced in all localities, but where this happens to be the case, the autoist who falls a victim to it is innocent of any wrong-doing in nine cases out of ten. The lamp has either been blown out or joggled out, and in any case the driver's first intimation that anything has gone wrong usually comes too late to help him. To make such a state of affairs impossible, the Royal Battery Company, 108 Duane street, New York, has brought out the Royal "Telltale Taillamp," the name of which speaks for itself. The lamp is electric and the outfit consists of a four-volt, 40-ampere hour storage battery, a governor and the Telltale bell or buzzer. Once wired up on a car, the Telltale gives warning whenever anything happens to extinguish the lamp, regardless of its cause, whether it be from a broken wire, burnt out filament, run down battery or other accident. The electric bulb furnished with the outfit is provided with one of the new metallic filaments, thus reducing the current consumption to a minimum, so that the makers guarantee 125 hours light on a single charge of the battery.

**INDEX TO ADVERTISERS**

Acetylene Gas Illuminating Co. 55	Cummer Co., Jos. W. 74	Kent Mfg. Works, A. 94	Premier Motor Mfg. Co. 101
Acme Motor Car Co. 60	Crown Soap Co. 72	Kimball Tire Case Co. 67	Prest-O-Lite Co. 67
Adams Co. 60	Cullman Wheel Co. 57	King Top Mfg. Co. 57	Progressive Mfg. Co. 69
Aero-Wear Auto Tire Sleeve Co. 61	De Luxe Motor Car Co. 60	Kinsey Mfg. Co. 65	Quinby Co., J. M. 58
Aerocar Motor Co. 60	Diamond Chain & Mfg. Co. 61	Konigslow, Otto 57	Raines & Co. 54
Ajax-Grieb Rubber Co. 63	Diamond Rubber Co. 58	Lansing-Mahon Press 79	Rainier Co. 61
American Ball Bearing Co. 70	Dietz Co., R. E. 58	Lavalette & Co. 55	Rajah Auto Supply Co. 62
Am. Brass & Alum. Works. 57	Dixon Crucible Co., Joseph 79	Lavigne Mfg. Co. 65	Randall-Faichney Co. 70
Amer. Motor Car Sales Co. Cover	Dorris Motor Car Co. 59	Lear Automobile Co., Oscar 60	Rapid Motor Vehicle Co. 91
American Motor Truck Co. 79	Dover Co., Geo. W. 53	Leather Tire Goods Co. 51	Reeves Pulley Co. 66
Anderson Forge & Machine Co. 57	Dow Portable Electric Co. 55	Limousine Carriage Mfg. Co. 58	Remy Electric Co. 55
Apperson Bros. Automobile Co. 90	Duff Mfg. Co. 65	Lipman Mfg. Co. 54	Renault Freres Cover
Ashtabula Bow Socket Co. 58	Echo Horn Co. 75	Lobe Pump Co. 57	Richardson Engineering Co. 57
Ashton Valve Co. 58	Eclipse Machine Co. 54	Locke & Co. 58	Robert Instrument Co. 54
Atlas Motor Car Co. 60	Eco Mfg. Co. 32	Locomobile Co. of America 90	Ross Gear & Tool Co. 57
Auburn Automobile Co. 60	Edgar Mfg. Co. 54	Logan Construction Co. 60	Royal Equipment Co. 61-64
Audel & Co., Theo. 53	Edmunds & Jones Mfg. Co. 54	London Auto Supply Co. 58	Rushmore Dynamo Works. 92
Aurora Motor Works. 83	Eldredge Electric Mfg. Co. 55	Long Mfg. Co. 72	Sallsbury Wheel & Mfg. Co. 54
Auto Pump Co. 62	Elite Mfg. Co. 65	McClellan, Chas. P. 58	Samson Leather Tire Co. 61
Auto Directories Co. 104	Ellsworth, J. M. 102	McCord & Co. 56	Sanford Mfg. Co., F. C. 57
Autocar Co. 91	Empire Automobile Tire Co. 62	Mandeville Steering Wheel Muff Co. 62	Saxon Lamp Co. 55
Autocar Equipment Co. 84	Excelsior Supply Co. 69	Manhattan Electrical Sup. Co. 55	Selden Motor Vehicle Co. 80
Automobile Supply Co. 54	Firestone Tire & Rubber Co. 61	Manhattan Storage Co. 54	Shaler Co., C. A. 65
Automobile Utilities Co. 54	Fisk Rubber Co. 31	Masury & Son, John W. 78	Shawver Co. 55
Auto-Shine Co. 55	Forest City Motor Car Co. 84	Mathewson Motor Car Co. 87	Smith Co., A. O. 82
Auxiliary Spring & Ventilating Button Co. 58	Franklin Mfg. Co., H. H. 109	Maxwell-Briscoe Motor Co. 110	Smith Mfg. Co., R. H. 53
Avery Portable Lighting Co. 93	Fry, T. C. & W. L. 54	Mayo Radiator Co. 57	Spacke Machine Co., F. W. 63
Baldwin Chain & Mfg. Co. 57	G & J Tire Co. 35	Merchant & Evans Co. 53	Spare Motor Wheel of Am. 86
Barnett Drop Forging Co. 63	Gabriel Horn Mfg. Co. 63	Merritt & Co. 62	Speed Changing Pulley Co. 68
Bartholomew Co. 79	Garford Motor Car Co. 105	Metzger, C. A. 65	Spicer Universal Joint Mfg. Co. 57
Bay State Stamping Co. 54	Gearless Transmission Co. 90	Michelin Tire Co. 61	Splittdorf, C. F. 55
Beaver Mfg. Co. 55	Gesler Bros. 64	Middley Mfg. Co. 57	Sprague Umbrella Co. 97
Behen-Faught Motor Car Equipment Co. 55	Gemmer Mfg. Co. 72	Miller, Chas. E. 75	Standard Automatic Lub. Co. 55
Bellfuss Motor Co. 74	General Accumulator & Battery Co. 55	Mitchell Motor Car Co. 100	Standard Battery Connection Co. 65
Beloit Supply Co. 85	Gibney & Bros., Jas. L. 55	Moline Automobile Co. 60	Standard Co. 73
Blastor Mfg. Co., M. E. 58	Grout Bros. Auto Co. 84	Montgomery Washburn Co. 53	Standard Connecting Rod Co. 64
Blomstrom Mfg. Co. 63	Ham Mfg. Co., C. T. 68	Moon Motor Car Co. 60	Standard Roller Bearing Co. 57
Boker & Co., H. 57	Hans, Edmund E. 71	Mora Motor Car Co. Cover	Standard Welding Co. 70
Bosch, Robert 89	Hardy Co., The R. W. 62	Morgan & Wright 76	Steam Carriage Boiler Co. 64
Boston Auto Gage Co. 65	Harris Oil Co., A. E. 57	Mosler & Co., A. R. 64	Stearns Co., F. B. 61
Bowser & Co., S. F. 91	Hartford Suspension Co. 33	Moss Photo Engraving Co. 91	Stevens-Duryea Co. 88
Boyle & Co., John 71	Hatcher Auto Parts Co. 75	Motz Clincher Tire & Rub. Co. 61	Stewart & Clark Mfg. Co. 69-99
Brown, Wm. W. 54	Hatfield Motor Vehicle Co. 60	Mound Tool & Scraper Co. 74	Streator Motor Car Co. 73
Brownell Motor Co., F. A. 62	Haynes Automobile Co. 60	Muller, Albert 62	Streit Machine Co. 55
Brush Runabout Co. 81	Healy Leather Tire Co. 59	Muttly Co., L. J. 58	Studebaker Automobile Co. 97
Buckeye Jack Mfg. Co. 79	Hedgeland Mfg. Co. 87	National Auto Accessories Co. 55	Success Auto Buggy Co. 61
Buckeye Mfg. Co. 60	Heinze Electric Co. 70	National Battery Co. 70	Supplementary Spiral Spring. 66
Buffalo Carbureter Co. 74	Heltzer Carburetor Co. 65	National Brake & Clutch Co. 50	Swinehart Clincher Tire Co. 72
Bullard Automatic Wrench Co. 81	Herz & Co. 59	National Motor Vehicle Co. 89	Thomas Motor Co., E. R. 106
Bullard Specialty Co. 62	Hess-Bright Co. 57	Neustadt Auto & Supply Co. 75	Thompson Sons Co., J. P. 64
Buob & Scheu. 58	Hicks Speed Indicator Co. 95	New England Motor Co. 76	Timken Roller Bearing Axle. 32
Byrne-Kingston Co. 83	Hine-Watt Co. 61	New York Gear Works. 65	Tincher Motor Car Co. 90
Cadillac Motor Car Co. 60	Hoffecker Co. 54	Nichols & Co., E. P. 58	Torbensen Motor Car Co. 63
Cameron Car Co. 107	Hoffman, Geo. W. 54	Nordyke & Marmon Co. 60	Tray Plate Battery Co. 74
Canton Drop Forge & Mfg. Co. 57	Holley Bros. Co. 32	Northway Motor & Mfg. Co. 57	Trebert Gas Engine Co. 61
Carr, F. S. 58	Holsman Automobile Co. 66	Nuttall Co., R. D. 56	Troy Carriage Sunshade Co. 85
Chadwick Engineering Works. 77	Hopewell Bros. 61	Oakes & Dow Co. 69	Tucker, C. F. 54
Champion Co., A. 62	Hotel Fredonia 98	Oakland Motor Car Co. 112	Uncas Specialty Co. 67
Chandlee & Chandlee. 53	Hotel Gibson 71	Ofeldt & Sons. 54	U. S. Fastener Co. 70
Chicago & Alton Ry. 67	Hotel Plney Woods Inn. 98	Olds Motor Works. 60	Veeder Mfg. Co. 83
Clark, E. S. 54	Hotel Rudolph 98	Owen & Co., R. M. 61	Vehicle Specialty Corporation. 64
Cleanola Co. 65	Hotel Tampa Bay 98	Pacific Tucking & Mfg. Co. 54	Walker Mfg. Co., E. C. 67
Cleveland Motor Car Co. 88	Hotel Tower 98	Packard Electric Co. 57	Warner Instrument Co. 96
Cleveland-Canton Spring Co. 72	Hotel Westminster 98	Packard Motor Car Co. 111	Warner Pole & Top Co. 58
Columbia Lubricants Co. 74	Howard Motor Works. 60	Palmer & Singer Mfg. Co. 61	Watt-Detroit Carbureter Co. 78
Comptoir d'Innovations pour Automobiles. 94	Imperial Motor Car Co. 60	Pantasote Co. 58	Waukesha Motor Co. 63
Conn. Tel. & Elec. Co. 76	Indestructible Steel Wheel Co. 64	Parish & Bingham Co. 57	Wayne Automobile Co. 61
Continental Caoutchouc Co. 61	Index Speed Indicator Co. 55	Parker, Stearns & Co. 72	Weed Chain Tire Grip Co. 64
Continental Motor Mfg. Co. 61	Jackson Automobile Co. 60	Peerless Motor Car Co. Cover	Welch Motor Car Co. 79
Cook's Sons, Adam. 82	Jamesville Mfg. Co. 62	Penn. Auto Motor Co. 60	Western Motor Co. 72
Cornin Motor Vehicle Corp. 79	Jeannin Auto & Mfg. Co. 79	Perfection Grease Co. 63	Weston Elec. Instrument Co. 75
Cornish-Friedburg Motor Car. 60	Jeffery & Co. Thos. B. 108	Perfection Spring Co. 62	Wheeler & Schebler. 96
Correspondence School of Motor Car Practice. 61	Jeffery-Dewitt Co. 76	Peugeot Freres 57	White Co., The. 102
Cotta, Chas. 62	Jenckel Motor Mfg. Co. 70	Pfanstiehl Elec. Laboratory. 54	White & Bagley Co. Cover
Cowles & Co., C. 54	Jenkins Specialty Mfg. Co. 70	Pierome Hide Co. 51	Whitney Mfg. Co. 70
Crown Battery Co. 74	Jones Speedometer. 55	Pierce Engine Co. 60	Winton Motor Carriage Co. Cover
	Johnson Sporting Goods Co., I. 58	Pirelli & Co. 67	Witherbee Igniter Co. 58
	K. W. Ignition Co. 55	Pittsfield Spark Coil Co. 68	Wright Cooler & Hood Co. 74
	Kellom & Co., Chas. F. 66	Portland Automobile & Motor Boat Show. 93	Wyman & Gordon Co. 53
		Precision Appliance Co. 55	York Motor Car Co. 84

# CORK INSERTS

(Patented)

## The Premier Motor Mfg. Co.'s Perfect Brake

Largest brake area of any American made brake.  
 Positive braking at all times.  
 Easy engagement,  
 Long life.

Are some of the advantages this Cork Insert Brake gives.

**National Brake & Clutch Co.,** Owner and Patentee  
 16 State St., Boston

STANDARD BRAKE COMPANY, Representative, 101 West 66th st., NEW YORK

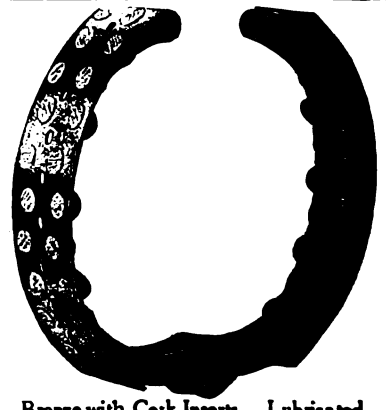

Bronze with Cork Inserts. Lubricated.

# THE AUTOMOBILE

## AUTOMOBILE AS A RAILROAD CONNECTION

PARIS, Feb. 11.—There are a score of big cities in Europe with railroad termini so arranged that travelers from different parts of the country are dumped down at widely-separated points and left to find their way from one trunk line to another as best they may. Travelers from the north of England to the British Channel reach London and are turned out at one of the string of stations in Euston Road; north-bound wanderers speed from the Mediterranean with more or less luxury and velocity to find themselves stranded in the south of Paris with no very tangible means of reaching a northern depot. Without any injustice to the horse, the links between northern and southern railroad depots in London and Paris—and on a smaller scale in other European cities—may be described as crude. After eight or ten hours in a Pullman, with all the luxuries that modern travel has yet devised or Europe adopted, it is at least humiliating to be jogged across the streets of a capital by a weary quadruped,

often sorely taxed to keep the combined load of passengers and baggage in motion under advantageous circumstances.

Both French and English railroad companies have realized that they owe to their passengers some better means of transportation between city termini than two lean horses, a corpulent driver and a venerable cab. Apart from any possible economy in the journey, those hotels which first replaced the horse service between their own doors and the railroad depot by a series of automobile 'buses, have had no reason to regret the change, in view of the additional publicity the new means of locomotion has brought them. There are now scores of instances in English cities in which both hotel and railroad companies use automobiles exclusively for completing a journey to outlying points or connecting up arrival and departure stations.

Two notable instances of the ousting of the horse have occurred in Paris within a few days, the Orleans line having



STEAM OMNIBUS WHICH HAS REPLACED HORSE SERVICE BETWEEN THE LYONS AND ST. LAZARE STATIONS IN PARIS.



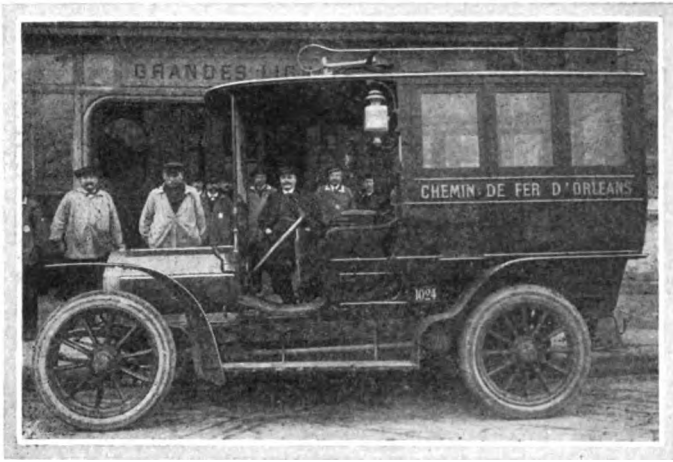

GASOLINE 'BUSES AWAIT ALL TRAINS AT ORLEANS DEPOT, PARIS.

put into service, at its magnificent station overlooking the Seine, a series of cabs and 'buses with special provision for carrying luggage, and the Lyons Company installing a service of steam 'buses between their own southern terminus and the Gare St. Lazare on the north side of the river.

Economic considerations demand that the taxicab should be a light, low-powered vehicle without the capacity for overloading, which is one of the redeeming features of the horse cab. Consequently for railroad work a special type of vehicle has to be designed, with provision for at least four passengers, and some place in which heavy trunks can be carried in safety. The Orleans company has met the situation by 20-horsepower four-cylinder cabs with closed bodies, the top of which is fitted with a metal gallery and built sufficiently strong to carry a heavy load. For larger parties small family 'buses, capable of carrying eight to ten passengers and the usual baggage attending such a group, are kept in constant attendance at the station.

Between the St. Lazare station and the Lyons depot, separated by four or five miles of crowded city thoroughfares, Darracq-Serpellet steam omnibuses now form a direct connecting link, uniting the two most important departure points of the city in a much more satisfactory manner than was ever done by the horse-drawn 'buses or the leisurely horse cab. In this case no special provision is made for passengers' baggage, the 'bus service being designed as a connection for the use of passengers between the two railroad depots. It is a connecting link, however, which will be much appreciated by those who have jogged over the paving stones in the old manner.

In all probability the adoption of the Darracq-Serpellet steamer for railroad work will prove to be the advent of steam automobile traction for the entire city of Paris. The lease of the present city omnibus company is on the point of expiration. It is not yet known who will obtain the next monopoly, but it is absolutely certain that when the change is made the main provision will be that every horse-drawn 'bus shall be taken off the streets of the city with the least possible delay. Among those most anxious to make the transformation is the Darracq-Serpellet combination with an army of steamers.

#### OLDSMOBILE MUDLARK REACHES NEW ORLEANS.

NEW ORLEANS, LA., Feb. 17.—Ralph Owen and the Oldsmobile "Mudlark No. 3" arrived this morning, having made the journey from New York via Buffalo, Pittsburg, Louisville and Nashville in twenty-two days. Owen had no mishaps worth mentioning, although he never encountered worse conditions than existed between Nashville, Tenn., and New Orleans.

#### STUDEBAKER CARRYING ARMY DISPATCHES.

With John Holm and William L. Walls as drivers, a 30-horsepower Studebaker carrying a message from General Frederick D. Grant, in command at Governor's Island, to all commandants at army posts between here and Ft. Leavenworth, Kan., left New York Tuesday morning, February 18. The route of the New York-Paris racers will be followed and the car will be driven night and day, each driver taking the wheel for twelve hours. Manager C. F. Redden, of the Studebaker Company, expects the 1,500-mile trip to be covered in ten days despite the adverse conditions.

#### EARLY JULY DECLARED TO BE A. A. A. TOUR DATE.

While no official announcement has been made on the date and starting point of the annual A. A. A. tour, according to an interview with Chairman Frank B. Hower in the *New York Times*, the week commencing Monday, July 6, has been decided upon, the most probable day being Wednesday, July 8. According to the same authority the start will be made at Buffalo, the run being an Eastern one with stops at Pittsburg, Philadelphia, New York, New Haven, Providence and Boston. Mr. Hower states that a definite announcement on date and place of the tour will be made in the near future.

#### A. A. A. FEDERAL REGISTRATION ACTIVITIES.

March 12, 1908, at 10:30 A. M., are the day and hour announced for the Federal Registration bill hearing at Washington before the subcommittee of the Judiciary Committee of the House of Representatives. Preliminary to this hearing, a conference of the delegates from the various clubs and associations will be held at the New Willard, Washington, D. C., Wednesday, March 11, at 8:30 P. M., and will be presided over by President William H. Hotchkiss and Chairman Charles Thaddeus Terry, of the Legislative Board of the association. It is urged that every automobile organization affiliated with the American Automobile Association be represented at the conference and hearing. The Automobile Club of Washington will entertain the visiting delegates informally at their clubhouse Thursday evening, March 12.

#### UP-STATE JUSTICE EMBEZZLES FINES.

ALBANY, N. Y., Feb. 17.—"Uncle" Jesse Van Ness, justice of the peace of East Greenbush, N. Y., has achieved an enviable reputation for his motorphobic tendencies. To put things briefly into the vernacular, "he soaked an autoist every chance he got, and the boys have been laying for him." Their turn has come as a result of an investigation undertaken by Bender & Hinman, attorneys in Albany, who were retained by the taxpayers of East Greenbush to find out what had become of the various sums of money collected by this "J. P." in the shape of fines. Though he imposed limit fines on almost every occasion, it has been found that all but \$200 of the money thus collected in the past two years has disappeared. According to the provisions of the law on the subject, such moneys are to be turned over to the supervisors within thirty days, or the latter must sue for it, but in the present instance neither step has been taken, while Van Ness has also violated practically every provision of the law calling for the filing of an accounting with the town board. The account was not itemized or verified, and the provision prohibiting an interested member sitting at a board meeting to pass on his own account was also violated.

As a defense it is contended that the board of supervisors passed a resolution authorizing the justice to spend the money thus collected in fines, but the taxpayers state that this resolution is void and accuse Justice Van Ness of having misappropriated and squandered about \$1,000. in support of which they cite specific instances to that effect.

## AMERICAN CHAMPION FOR GRAND PRIX

AMERICA will have as her representative in the French Grand Prix, the swiftest and most keenly contested automobile race of the year, one Thomas Flyer racing car, with Montague Roberts at the wheel. The decision to line up against France, Germany, Belgium, Italy and England in the race to be run on the Dieppe circuit the first week in July was only made at the last moment, the engagement of one car being cabled but a few hours before the official closing of entries. News has not yet been received from France as to the exact composition of the teams which will dispute the first race under the new international rule, but sufficient is known of the intention of European factories to predict the appearance of teams from every factory of importance in five European countries, providing probably fifty cars.

The Thomas people state that they will use a stock chassis in the European race, with such adaptations as are necessary for the fast course on which it is intended to be run. The Ostend rule, under which the Grand Prix is being run, allows a bore or not more than 155 millimeters (6.102 inches) for four-cylinder engines, there being no limit to the stroke; total weight must not be less than 1,100 kilos. As the 60-horsepower Thomas Flyer is 5 1-2 inches bore and stroke, it will doubtless be the lowest-powered car in the race, all the European constructors having decided to build up to the maximum bore with a stroke varying from 6 1-2 to 7 1-2 inches. Last year, with engines averaging 7 by 6.2 inches bore and stroke, an average speed of 70 miles an hour was attained by the two leading cars, the highest rate of travel ever reached in a long-distance road race. Despite the reduced bore, many constructors believe they can equal this record. Whether this is done or not, it is certain that the winner will be an exceedingly fast car.

### Exact Date Now Fixed for Grand Prix.

PARIS, Feb. 10.—Monday and Tuesday, July 6 and 7, are the days chosen for the two Grand Prix races to be run on the Dieppe circuit by the Automobile Club of France. In all probability Monday will be reserved to the racing runabouts limited to 3.9 inches bore for a single-cylinder car, and Tuesday for the four-cylinder 155-millimeter racers. Though this would be the most natural way of holding the two races, an official decision has not yet been arrived at by the Racing Board. Despite minute precautions, there is an ever-present fear of accident, and should any mishap of a serious nature occur on the first day there is a possibility of the government forbidding the running of the second day's race. It is for this reason that some of the members of the Racing Board would put the big race first. Though there is every probability of as many as 60 competitors engaging in the Voiturette Grand Prix, there is in reality little fear of accident, the course being wide, tarred, stoutly barricaded and guarded by several

infantry and artillery regiments, gendarmes and local men.

Weighing-in for all cars will doubtless take place Saturday and Sunday preceding the races. On the Sunday, also, it is intended to hold motor boat races off Dieppe, unless there should be promise of British entries, in which case the nautical races would be held on Saturday afternoon, in consideration of the English objection to Sunday sports.

Details in connection with the course are being pushed forth with rapidity. The race having been held here last year, there is, of course, comparatively little to do. A few more trees may have to be chopped down, a little patching and rolling done, and the entire course retarred. But all this devolves upon the Dieppe authorities, who have undertaken, in consideration of the race being held in their district, to furnish a perfect set of roads. Grandstand arrangements are entirely different to those of last year. Instead of being



RACING BOARD INSPECTING COURSE ON A POWERFUL PANHARD.

on the outside of the course, with their backs to the sea, the stands will be on the inside, on the leg of the triangle running from Dieppe to Envermeu. They will be sufficiently near the hairpin turn for spectators to look across the angle and watch the cars approach the "hairpin." At each end of the main stand a high tower will be erected, the privileged occupants of which will have a unique view of the cars running parallel with the seashore, the "hairpin" turn and the straight-away in front of the grandstands. To the rear of the grandstand seats is planned a wire promenade, from which it should be possible to obtain an excellent view of both lengths of road. Gasoline and tire stations will be directly in front of the grandstands, on the out-

side of the circuit. As the regulations call for all work to be performed by the driver and his mechanic, and there will be only one other station on the course, occupants of the grandstands will always have before them plenty of interesting work.

Connection with the outside of the circuit will be made at the grandstands by a wide tunnel, and at various other points on the course wooden bridges will be constructed for the use of foot passengers before and during the running of the races.

Governmental permission to hold the Grand Prix on the Dieppe circuit has been accorded by Premier Clemenceau. A deputation consisting of the Dieppe authorities and officials of the Automobile Club of France presented their formal request this week and were immediately assured not only of the Government's approval, but of the intention of the Premier to be present if possible. No additional entries have been received for the Grand Prix. For the voiturette race to be run on July 6, ten cars are now engaged, including teams of three from Isotta-Fraschini, Lion-Peugeot, Rolland-Pilain, and one Fouillaron. One voiturette builder, winner of the last race of this nature, at a speed of over 40 miles an hour, has stimulated interest by declaring that he will



MAYOR OF DIEPPE AND RACING BOARD OF FRENCH CLUB.

average 60 miles an hour with a 3.9 bore single-cylinder car. The engine will have a stroke of 5.9 inches and will run at 2,500 revolutions per minute. Such extraordinary results were obtained at the voiturette race in the fall that the constructor's declaration is generally accepted as more than an idle boast. A special trophy valued at \$600 has been offered by the *Petit Parisien* to the winner of the voiturette race. The town of Dieppe has also come forth with the announcement that it will subscribe a handsome trophy to be presented to the winner of the Grand Prix, whatever his nationality. An erroneous impression had got abroad that this trophy would only be awarded if the winner of the Grand Prix were French. Special prizes will probably be offered for the fastest flying kilometer.



CLUB DELEGATION VISITING PREMIER CLEMENCEAU.

WHAT IMPRESSED MICHELIN IN AMERICA.

PARIS, Feb. 10.—Edouard Michelin, the younger of the two brothers who created the great tire firm, has given a Paris reporter the benefit of some of the ideas which struck him as particularly good during his recent visit to the States in connection with the formation of the American Michelin Company and their new factories at Milltown, N. J.

"While not going to America to study character and conditions, but to work, I was particularly struck with the importance of time in all industrial undertakings. Occasionally we admit time is valuable; but in America time is the great principle of all industrial movements. To build our factory we got in touch with several firms. All of them gave us three prices, for three months, six months, and one year, with enormous differences. It was not a matter of the importance of the labor, they explained, but one of material. Should they use the steel, iron, stone, etc., kept in stock, at prices demanded by those who had the material ready, or should they pass special contracts, causing a delay, but allowing special rates.

"The way in which supply dealers of all kinds interest themselves in their customers struck me particularly. Here

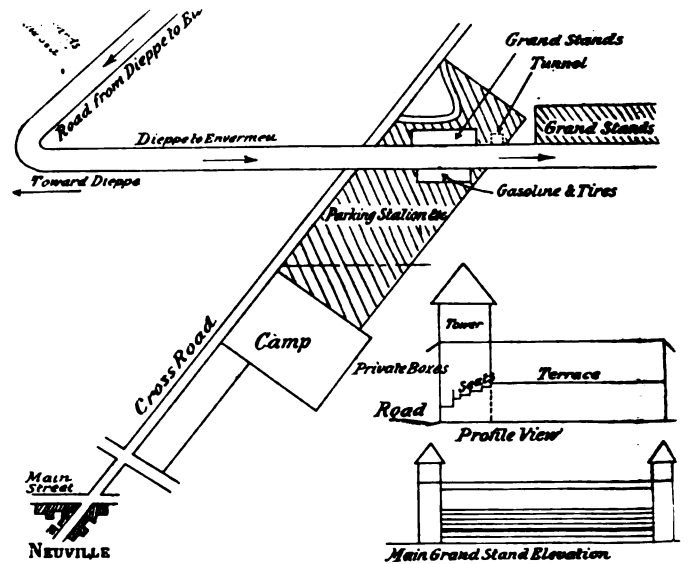

HOW GRANDSTANDS WILL BE ARRANGED ON DIEPPE COURSE.

in France we ask for something, a price is stated, we agree, we pay, the goods are delivered, and that is the end of it. There is nothing of that in the States. Every dealer or supplier gives you the full benefit of his experience.

"When we need a fire insurance an inspector comes, asks a few general questions, just for formality, and the company gives its rates, generally very high. In America the examination is the most important part of the affair, and the inspectors are the grand masters of the company. They examine the affair and say, 'We want so much per cent.; but if you will let us organize your factory against fire risks, and make use of our experience, which has covered hundreds of examples, we can give you much better terms'; and often those terms show a reduction of 50 per cent.

"Another good point is the confidence you can have, with but rare exceptions, in the firms estimating to undertake work for you. The base of this honesty is the power of credit. A man operates, in general, with ten times what he really possesses, and he is always seeking to increase his figure. Thus there is necessity for credit, and equal necessity to work squarely, or see the credit lost forever. It is an open, public credit, and the most level-headed man is the one who always keeps on the honest side. It was this system which was one of the causes of the last crisis. The American just coolly cut out a few rotten affairs, that is all."

## EARLY DIFFICULTIES ON RUN TO PARIS

ALMOST before the round-the-world tourists had got out of sight of the City of New York on Wednesday, February 12, a thaw set in, transforming a naturally unsatisfactory highway into a veritable quagmire. Instead of reaching Albany the first night, as arranged on the schedule, no car got beyond Hudson, 116 miles out, two even stopping at Peekskill after a run of but 44 miles. Despite the reiterated statement that American roads are not like those of Europe, the foreign drivers were totally unable to realize under what conditions they would have to travel within a few hours of the start. The result was that instead of being unprepared for the run, as some who evidently had had no opportunity

the train at Ogden, Cheyenne, or some more easterly point if necessary, the Frenchman is probably more sagacious than is generally acceded in abstaining from a race which could not do him one iota of good, and might incapacitate him for the later trip through Siberia, Russia and Europe. Paul Pons and his little single-cylinder Sizaire-Naudin were worthy of a better fate. At Montrose, 40 miles out, rear axle troubles necessitated the dismounting of that organ, an operation occupying three days, and when the work had been done a further tie-up occurred at Red Hook, 96 miles from the starting point. Unable to utter a word of English, with no American agency to which they could apply for parts,

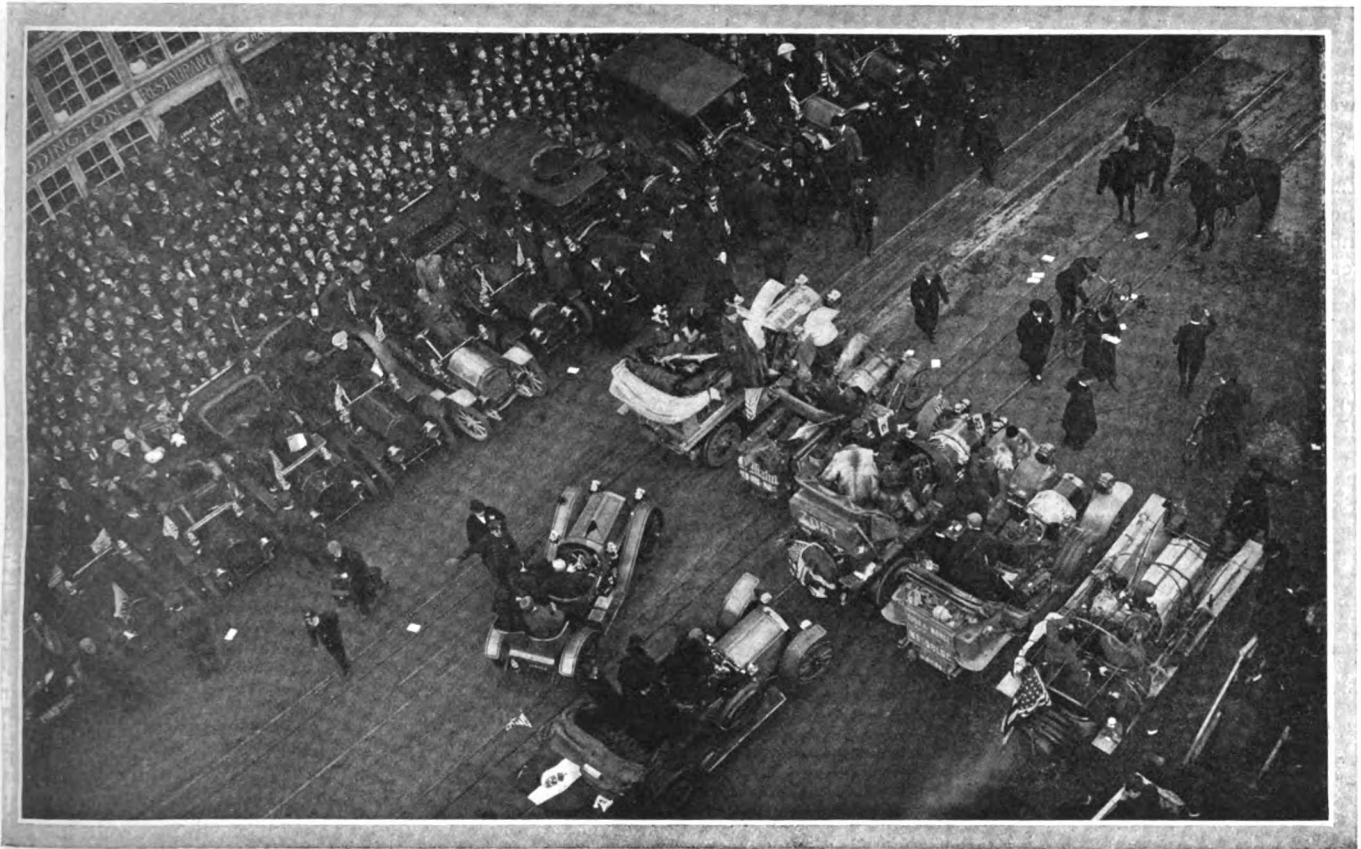

HOW THE CONTESTANTS LOOKED FROM AN UPPER STORY OF THE "TIMES" BUILDING JUST BEFORE THE START, WEDNESDAY, FEB. 12.

of examining the machines in detail have declared, the competitors were overprepared. Quantities of stores that could have been of no possible value until Arctic regions were reached were unwisely carried on the cars the first three days.

Very early in the run Roberts showed that he had the fastest car in the Thomas Flyer, the Italian Zust and French De Dion, however, keeping close behind. The Protos with its German crew made good going, but was too ponderous for speed. Godard, who had privately declared before setting out from Times Square that his Motobloc would be in the rear all the way across the United States, thoroughly lived up to his promise, and though having but trifling mechanical trouble, was 100 miles behind the leaders as early as the fourth day. As all the competitors will have to ship on



A TRIO OF NOTABLES.  
Hoyt fires starting gun, Morris and Thompson assisting.

the Sizaire crew labored under heavy disadvantages, yet Pons says he will continue.

After blazing a trail for two days, Roberts concluded that it would be wiser policy to share the honor of leading with his competitors, and accordingly fixed up an agreement with the crews of the De Dion and Zust whereby each car alternately made a track through the snow and mud in which the others could follow. Some idea of the difficulties of traveling through New York State can be gathered from the fact that though taking advantage of every hour of daylight the mileage rarely got above one hundred, the figures for the leaders on the first six days being 116, 90, 69, 87, 109 and 95.

Undoubtedly the most difficult portion of the journey was the run to Geneva on the fourth day. Heavy rain had followed the fall of snow, giving a surface which alter-





THOUSANDS SAW THE START OF THE LONG RUN.

nated between twelve inches of mud and snow drifts from two to three feet in depth. At Dismal Hollow, an appropriately named spot in the Montezuma marshes, the three leaders, Thomas, De Dion, and Zust, found themselves hopelessly stalled at the foot of a steep hill with several feet of snow ahead and swamps on all sides. Only after three hours' labor and the assistance of teams of horses were the cars able to get out of their difficult position and proceed to Geneva.

#### Thomas Led the Way to Buffalo.

BUFFALO, N. Y., Feb. 17.—Buffalo has received, entertained and passed on the New York-to-Paris cars. Montague Roberts, driving the Thomas Flyer, was the first to reach this city. He got here about 2:15 o'clock Sunday afternoon,



ABOVE YONKERS, ALONGSIDE HUDSON, TRAVELING EXCELLENT.

something like two and a half hours ahead of his French competitor, the Dion-Bouton. The Zust, flying the Italian flag, got in Buffalo at 5:15 o'clock Monday morning, registered at the Western Union office, and, finding nobody here to welcome them, the drivers passed on towards Cleveland. The Italians believed the other two cars had got right on, but when ten miles along the lake shore learned otherwise. The Thomas was met at Williamsville by representatives of the E. R. Thomas Motor Company and the Diamond Rubber Company, with whose tires it is equipped. The Pierce Company lent all local assistance to the foreigners.

#### Leaders Nearing Chicago; One Car Quits.

After seven days' running, Roberts had reached Toledo, distance 785 miles, with the De Dion 29 miles behind at Fremont and the Zust making a moonlight run from Cleve-

land to overtake the faster cars. The German Protos put into Erie for the night. Godard, still refusing to be hustled, stabled his Motobloc at Buffalo, thoroughly satisfied with his performance. After every possible attempt to repair its broken differential, the little Sizaire-Naudin has been withdrawn from the run, after covering but 96 miles. It was impossible to obtain a new rear axle in this country.

#### Interrupted Progress of the Werner.

PHILADELPHIA, Feb. 17.—A man may be French and a dare-devil, and may even have been the first to suggest the New York-Paris race, but that does not signify that he is capable of running an automobile safely. Such, with much gesturing and shrugging of shoulders, is a free translation of what M. Drieghe, representative of a Paris newspaper, says about M. Lelouvier, who ran the Werner independent entry over



ROBERTS AND THOMAS CAR LED THE WAY TO BUFFALO.

from New York on Wednesday, and, according to his companions—M. Hohmann bears out M. Drieghe's statements—demonstrated that he wasn't familiar with the game.

Barring counters and swings, the two days spent here waiting for the Quaker City Automobile Company's men to whip the Werner back into shape were a regular Donnybrook Fair performance. Verbal battles in pure Gallic were numerous, and when the start was made Saturday morning Lelouvier had been deposed from the wheel, and Drieghe was in his place. The former sulked and refused to go along, but bade his compatriots an apparently effusive farewell and hied him back to New York, some said to wire Paris to stop the rebels, others to get another car and beat the Werner.

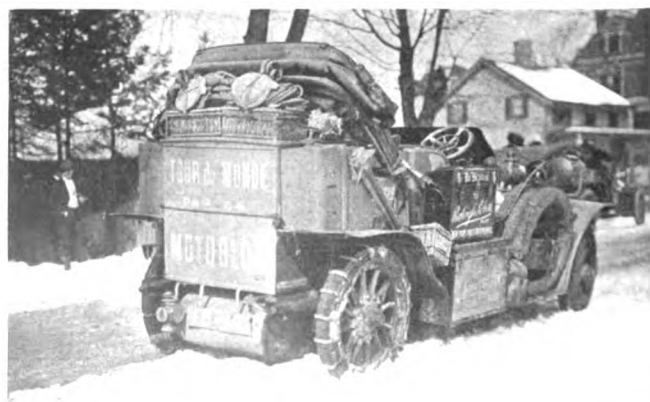

PONDEROUS, THOROUGHLY-EQUIPPED, SLOW-GOING MOTOBLOC.

## CLEVELAND'S SHOW ATTRACTIVELY SUCCESSFUL

CLEVELAND, Feb. 17.—It didn't look much like depressing times at the opening to-night of Cleveland's seventh annual automobile show. Never before in the history of Cleveland shows was there so large and brilliant a crowd and never before such a varied and brilliant display as were to be seen in Central Armory.

"There are only two cities in the country that have anything at all on Cleveland in the line of auto shows, and those are New York and Chicago," said a man this evening who has attended similar events for years. This year the show committee spared no expense to make this the most attractive local show on record. They imported from New York M. A. Singer, who has had charge of decorating Madison Square Garden for several previous shows, and they gave him almost unlimited leeway to make this the best ever. The color scheme is white and gold. Canopies in white are draped all around the building. The pillars through the center are white. Along the railings of the galleries and clustering around the pillars in the center and outlining the signboards are lights shaded by tulip shaped art glass. The ceiling is draped from the center in gold and white. Surmounting the railings of the gallery are posts with Nernst lamps around, and under the gallery are rows of gold and white lights, while the chief lighting effect comes from a dozen huge globes of incandescents hung from the ceiling. The entire effect is lighter and brighter than ever before. The arrangement of the floor spaces differs from that of previous shows. There are no center aisles. Instead there are the posts through the center with 12-foot aisles at the sides.

The Cleveland show committee undoubtedly made a wise move in delaying the show until February instead of holding it in the circuit of big national shows. The financial feeling is much better than it was two months ago, and the dealers all report that the prospects for business are growing brighter every day. The curtailment of outputs of many of the big makers had made some of them worse off for prompt de-



HOW THE CLEVELAND SHOW LOOKS FROM CENTRAL ARMORY GALLERY.

liveries than ever before. Even people who had plenty of money were afraid to do business two months ago, where now they are satisfied with the outlook and are ready to close deals.

One of the noticeable points about the show this year is the predominance of the six-cylinder. Last year but three "sixes" were shown at the Cleveland show, and none of this type was built by Cleveland factories. This year the Winton factory is committed entirely to "sixes"; the Peerless, the Stearns and the Royal all have their big models, while among the out of town "sixes" on exhibit are DeLuxe, Thomas, Ford, Olds, Pierce Great Arrow, Stevens-Duryea, Chadwick, Premier, National and Stoddard-Dayton.

Of course comparatively little is on exhibition here that has not been shown at previous big shows. Paul Gaeth, who has catered heretofore largely to his home trade, but this year has gone after business in many sections of the country, exhibited his 1908 models at New York and Chicago, but also reserved two or three new ideas for the Cleveland show. One of these is a device for starting the motor on the spark with a make-and-break type of ignition. A new model, known as the Tourabout, has a low hung forward slanting top and a "V" shaped removable glass windshield, the whole design of the car being with a view to reducing the wind resistance to a minimum. Another new Gaeth model is a sort of a semi-limousine. For winter use the rear portion of the car is closed up tight, while for summer use the large rear and front window can be removed and the side windows, which are in two sections, also come out, giving free circulation of air on all sides.

This year there are no racing cars, or at least cars that are described as such. In fact, there are few novelties. One of the most interesting is what is said to be the first steam auto built in this country, by Achille Phillin in 1890 for advertising purposes, and exhibited at Tattersall's, Chicago, in 1892. The list of the exhibitors is as follows:

### AUTOMOBILES.

Winton Motor Carriage Co., Cleveland.	Metropolitan Motor Car Co. Olds Motor Works, Lansing, Mich.
Peerless Motor Car Co., Cleveland.	Woods Motor Vehicle Co., Chicago.
The White Co., Cleveland.	Leonard Motor Co.: Jackson.
Garford Motor Car Co., Elyria.	Byrider Electric Mfg. Co., Cleveland.
Elmore Motor Car Co., Clyde, O.	Oakland Motor Car Co. Brush Runabout Co.
Gaeth Auto Co., Cleveland.	Wentworth Motor Car Co.: Ford.
Rauch & Lang Carriage Co., Cleveland.	C. M. Chatche & Co.: Wayne.
Price Carriage Co.: Baker Electric.	Reese Motor Car Co.: Corbin.
H. S. Moore: Stoddard-Dayton.	Royal-Tourist, Columbia (electric).
Chisholm & Phillips Auto Co.: Stevens-Duryea.	George S. Patterson: Premier, Reo.
R. H. Magoon Motor Car Co.: Chadwick, Jewell, De Luxe.	T. C. Whitcomb Auto Co.: Rambler.
Hall Bros.: Cartercar.	Studebaker Auto Co., South Bend, Ind.
Ohio Motor Car Co.: Stearns, Cadillac, Columbia (gasoline), Columbia (electric), Detroit Electric.	Auto Shop Co.: Franklin, Thomas.
Standard Automobile Co.: Packard, Buick.	Cayuga Motor Car Co.: National.

### ACCESSORIES.

Fisk Rubber Co., Chicopee, Mass.	K. & W. Ignition Co., Cleveland.
Diamond Rubber Co., Akron, O.	Westinghouse Elec. & Mfg. Co., Pittsburg.
B. F. Goodrich Rubber Co., Akron, O.	Ferro Machine & Foundry Co., Cleveland.
Goodyear Tire & Rubber Co., Akron, O.	Howe Scale Co., Illinois City, Ill.
Ohio Rubber Co.	Columbia Refining Co., New York.
Jones Speedometer Co., N. Y.	Echo Horn Co., Cleveland.
Warner Instrument Co., Beloit, Wis.	Hartford Suspension Co., N. Y.
Veeder Manufacturing Co., Hartford, Conn.	J. P. Davies Co., Dayton, O.
National Carbon Co., Cleveland.	Cleveland Tanning Co., Cleveland.
Perfection Spring Co., Cleveland.	Standard Welding Co., Cleveland.
Charles E. Miller, New York.	Simpson & Grey, New York.
S. F. Bowser & Co., Ft. Wayne.	Collister & Sayle, Cleveland.
American Ball-Bearing Co., Cleveland.	George A. Rutherford Co. Auto & Supply Co.
N. Y. & N. J. Lubricant Co., New York.	Austro-American Separator Co. L. J. Mueller.
Gabriel Horn Mfg. Co., Cleveland.	Continental Agency Co. William Taylor Son & Co. Crawford & Soper.
Sprague Umbrella Co., Norwalk, O.	

## SOUTH WANTS A. A. A. TOURISTS TO TRY ITS ROADS

NEW ORLEANS, LA., Feb. 15.—The cry of the South for the A. A. A. tour for 1908 is becoming louder and louder. The South thinks that she ought to have it this year, and the contention seems to be justified. But as the West is also making a strenuous effort for this tour, the opposition is much greater. The East has had the tour for two seasons now, and the protests from the other sections of the country are timely. Local automobilists are of the opinion that more real good can be accomplished by holding the tour in some other section of the country than the East. They argue that the East and Central Northern States are far ahead in regard to the automobile and its running mate—good roads. The spirit of good roads improvement is just in its infancy in the South, and such a tour as that of the A. A. A. will undoubtedly do much toward fostering this movement and giving it a healthy start.

The tour just completed by Ralph Owen in his Oldsmobile "Mudlark No. 3," from New York to New Orleans, has been watched with more than ordinary interest by automobilists all over the South, and, in fact, in the whole country. The route selected by Owen partially was a virgin one, as far as the auto is concerned, but he made excellent progress, despite the weather conditions and the season.

Already a number of prominent automobile enthusiasts in this city and other Southern cities are advocating the use of the route taken by Owen as a good one for the next Glidden tour. At any rate, the result of his tour will doubtless have much to do with the selection of the route when the time comes. Southern autoists contend that in the A. A. A. the South gets little recognition.

Several other routes have been suggested by prominent local members of the Louisiana Automobile League. One plan is to effect a compromise with the West, and make a Western-Southern tour, beginning, say, at Denver and ending at New Orleans. Another is to make the start from New York, fol-

low the Coast States to Atlanta, and then swerve westward. All may rest assured that the South will make strenuous efforts to land the Glidden tour either for this year or next. They are willing to let the West have it this year, if the South can be assured it for 1909. And it looks as if they might get it, for 'tis a "solid South" for the A. A. A. tour.

### North Carolina Has a Route for A. A. A. Tour.

CHARLOTTE, N. C., Feb. 18.—The Greater Charlotte Club, an industrial organization, has submitted to the American Automobile Association a route for the next Glidden tour, to include many Southern cities. The club is very anxious to have the automobile tourist come through the South, contending that as good roads can be had in this section as in any part of the country, and believing that to have the tourist touch various Southern cities will have a great effect in securing better roads for the South.

The American Automobile Association, through its Touring Board, has assured the Greater Charlotte Club that its proposed route will be carefully considered by the committee having the matter in hand, and that the South's merits will be given due consideration.

The route as outlined for the tour is over a country with ample hotel accommodations at intervals of 100 to 150 miles, which is necessary for the several hundred contestants and officials. The proposed route begins at Buffalo, the starting point, and will reach as far South as Atlanta, at which point the route will turn back northward.

The cities included in the route are Cleveland, Akron, Columbus, Dayton, Cincinnati, Ohio; Lexington, Frankfort and Louisville, Ky.; Nashville, Murphysboro, Chattanooga, Tenn.; Rome, Atlanta, Athens, Ga.; Greenville, Spartanburg, S. C.; Charlotte, Winston, N. C.; Danville, Lynchburg, Staunton and Fredericksburg, Va.; Washington, Baltimore, Philadelphia and New York City, back to the starting point.

## NEW JERSEY AND ITS TROUBLESOME AUTOMOBILE LAW

NEWARK, N. J., Feb. 17.—Exactly what will be the outcome of the various conferences between the automobilists and the State officials concerning a revision of the present so-called Frelinghuysen law remains to be decided.

Last week Senator Frelinghuysen introduced at Trenton a set of amendments to his own law, the registration fees being raised from the present rates to the following scale:

Class.	H.P.	Fee.
First .....	11-15	\$3
Second .....	16-20	5
Third .....	21-25	10
Fourth .....	26-35	15
Fifth .....	36-50	20
Sixth .....	51-70	25
Seventh .....	71-90	35
Eighth .....	91-120	100

The drivers' license fees are raised from \$1 for drivers of vehicles below 30 horsepower and \$2 for drivers of 30 horsepower and above to the following scale: \$1 for first-class, \$2 for second-class, \$3 for third-class, \$4 for fourth-class, \$5 for fifth-class, \$10 for sixth-class, \$15 for seventh-class, \$25 for eighth-class.

To-day W. C. Crosby, chairman of the legislative committee of the New Jersey Automobile and Motor Club, and R. A. Greene, representing the dealers of the State, visited Trenton and had a conference with Governor Fort, Senator Frelinghuysen and Commissioner J. B. R. Smith. Senator

Frelinghuysen stated he would be favorable to a new schedule calling for \$5 for anything from 1 to 19 horsepower, \$10 for 20 to 39 horsepower, \$15 for 40 to 59, and \$25 for 60 or greater horsepower machines. It was also decided to issue no manufacturers' licenses except to New Jersey dealers.

Reciprocity in registration for automobilists from other States was announced by the State official to be impossible at this time. Apparently the present administration considers that the automobilist should contribute most liberally to the upkeep of the highways, but the impression continues to prevail that visitors from other States will be fewer than ever in New Jersey this year.

Commenting editorially, the Newark News says:

The general criticism of the proposed amendments lies in the fact that they aim solely at increased revenue, rather than greater safety for the traveling public, and in doing so exact tolls from the automobilists in general that are hardly equitable. \* \* \* In this connection it is only fair to ask why the automobile is the only vehicle which must pay for the wear entailed upon the roads. Granting that it is more destructive to macadam than others, it is probable that more wear is entailed by horse-drawn vehicles, because they are so much more numerous. Certainly roads were worn before automobiles were dreamed of, and certainly roads are worn to-day by "sharp shod" horses and the steel tires of wagons and carriages. It would seem, therefore, that if road users are to keep roads in repair, which is entirely logical, all vehicles should pay an equitable tax. It may be popular to shoulder the entire burden on the motorist, but it hardly squares with one's sense of justice.

# PROBLEMS IN THE REPAIRING OF AUTOMOBILES

By THOS. J. FAY, E.E., PRES. SOCIETY OF AUTOMOBILE ENGINEERS

It would seem a simple matter to replace a broken part in an automobile, using the broken part as a pattern to go by. The duplication of the part may be a plain task, requiring no great skill; but it does not of necessity follow that the repair so made will be satisfactory.

Consider, for instance, a *cardan* shaft for, say, a 30-horsepower car, with a diameter of 40 mm. and of regular contour. It would be very easy to duplicate the size in a new one, using the old shaft as a guide in the process. This is not to say the new shaft would be the equal of the one displaced, the materials might not be of the same quality.

A repair then does not consist in merely duplicating the part from the *size* point of view. The *materials must be duplicated as well*, or, better yet, since the displaced shaft showed lack of staying qualities, to use a better grade of materials in the new shaft would be more to the point. On the other hand, to use a greater section of the same, or an inferior grade of materials, would not be a justifiable procedure for several reasons, among which the question of the increase in weight is one never to be lost sight of. If a car is made of inferior materials, the question of the quality of the materials to use in the repair of the same is still an important matter, since to prevent future rupture of the same parts would be the important matter.

A car may be *truly good* in the main, while the same car may be most unsatisfactory on account of the repeated failure of some one or two of the important parts, thereby causing service interruptions and costly repair bills.

It is the repair man who can remedy such matters, because it is to the repair man the car will go in quest of balm for its wounds. It is the repair man who should alleviate the distress of the suffering autoist. If the automobilist is accorded no more than *further license* to put up with additional interruptions of service at additional cost, *'tis not a repair at all*.

## Things That Have to Be Determined.

Does it come within the province of the repair man to determine as to the adequacy of the strength of the parts? Not of necessity. Indeed, there is no need to determine as to the *facts!* If the parts rupture, they are not of the requisite strength.

The history of the failure will determine much towards clearing up the difference as between a rupture due to a clear accident and that involving the inferiority of the material. It might be said, instead of inferior material the section is below the requirements; this is not the best way to look at the matter, since, if the materials are not of the best, using a better grade of material has the effect of rendering the section adequate without increasing the weight.

But, supposing the material is of the best to be had. Even so, it will be possible to attain additional strength by a *heat treatment*. In this way it will still be possible to keep the weight of the car within the original limits. If the weight question is not kept in mind there is no telling where the car will end from the weight point of view.

If, on the other hand, the materials are of the best possible to use and they are heat treated, to afford the maximum strength, yet with all the parts fail to sustain the load, it would be a reasonable inference that the section should be increased.

It does not follow some incongruity of design may be at the seat of the evil. There may be a shoulder, an abrupt turn, or perhaps a lateral, fixing the point at which the stresses will be concentrated. A little thought, some slight alteration, and the difficulty will disappear.

Is it worth while to the repair man to thus expend *gray matter?* Is it not his plain duty? Certainly! For why is a car sent to a repair shop, if not to be put in good repair?

Surely a fault in the car, such as will lend uncertainty to its performance, renders it otherwise than in good repair.

It is not proper to fall back on the presumption of original defect. If the owner of a car wants the same put in good repair, the order includes all faults, original or incidental to service. Of course, this is not to say that one should redesign every car that comes in for repair. This is not the point at all.

The point is that if a member ruptures, and it is to be replaced, some effort should be made to render the repair of a permanent character. "*Once well done, twice done.*" If a little investigation will end in the disclosure of the fault in design at the bottom of the failure, to take the time is not only desirable, but essential.

If it is plain that the replacements should be of materials at least as good as the materials failing in *normal* service, it is equally plain that the repairman should pursue some course consistent with the needs of the occasion.

True, it would not be possible to have a thorough investigation of the ruptured parts made each time a car is entered for repair; but it would be possible to follow at least one of two courses. That is to say, it would be desirable to know what the respective makers use by way of materials in the various parts of their cars; or, to provide certain standard grades of materials, for the respective parts in the absence of definite knowledge in relation to the practice of the respective makers.

These are not matters beyond the pale of plain practice, nor would one have to stay up o' nights to the tune of midnight oil in quest of the requisite amount of information. Surely it is well worth while.

## Value of Good Material in Repair Work.

The question of the price of good material for use in repair work is a matter of almost no moment at all, because the proportion of the whole cost of a repair, directly chargeable to material, is generally less than ten per cent. Whether or not the ten per cent. is halved or doubled is certainly secondary to the matter of a permanent repair.

If a repair shop desires to be particular about this matter of the material, a very simple and quick way to ascertain the required quality of the material to be duplicated might be as follows: Take discs of standard grades of materials of known characteristics, say, one inch in diameter, and possibly one-quarter-inch thick (thickness of no great importance), polish one side of the discs and, with a magnifying glass (power of the glass twenty diameters), compare the parts to be replaced with the standards until they match up. It will, of course, be necessary to polish a spot on the parts to be replaced to render the comparison more certain.

Care should be exercised to carefully mark the respective standards, thereby to know of what materials they are composed; he who depends upon memory skates on thin ice. The magnifying glass of the power, as above given, may be had at any first rate optician's at a cost of about twenty dollars.

It is not even necessary to know the *chemical composition* of the materials of the standard discs, or much besides, provided the materials are of staple brands of the different grades, readily procurable, with some certainty.

The method is but an approximation, not to be regarded as a fine test of the products; it is purely relative, but it does serve a very useful purpose. Certainly there are other more exacting methods of establishing the facts, but they take more time, require more skill, ending in more uncertainty in the hands of the busy practitioner.

It takes a little practice to render one proficient in the use of a twenty to one glass, the lens being scarcely more than 1-8-



inch in diameter. It is something to have good light, and a clear north exposure may be superior to artificial light; but to invariably resort to the same source of illumination may be a point in favor of uniform results.

Generally when a shop awakens to the fact that the methods in vogue are not in keeping with up-to-date practices, the first shot out of the box is to go to extremes. The end is as the frog in the well. The best way is to creep—then walk—get used to somewhat more exacting methods, and persist.

Conscientious repair work is no more necessary than honest banking methods, *but it is no less a necessity*; the shop that does pursue an honest and skillful course will be prosperous long after the other kind *lies slumbering in oblivion*. This is not to say the price of the repair should be low, the price question is a separate matter to be governed by the cost of the work and the profit desired.

If, however, the price is to be the same if the quality of the work is good or otherwise, then dishonesty runs rampant in the latter case. At all events, to claim to be doing things in a skillful way, with facts to the contrary, is but to dig a grave, and *thereby hangs a tale*.

The question of how the respective materials will look under the glass is not a matter to worry about, since it will be plain to the investigator, when the part to be replaced, looks like some one of the standard discs. To be able to match up, it is desirable to provide discs of the various grades of materials usual to automobile practice, they being as follows:

- (I) Mild Bessemer steel.
- (II) Basic Open Hearth steel.
- (III) Acid Open Hearth steel.
- (IV) Acid Open Hearth steel (Basic bottom).
- (V) Nickel steel.
- (VI) Chrome Nickel steel.
- (VII) Chrome Vanadium steel.
- (IX) Swedish Iron.
- (X) Crucible steel = (III), (V), (VI), (VII), (VIII).

The chemical composition of the various steels will depend upon the service to be rendered and the process. Under the glass at twenty diameters it will not be possible to tell as to the process by which a product may be fabricated, but it will be possible to note the difference as between (I) and (V), or (II) and (VI) without great skill.

It will also be easy enough to pick out (IX) from say thirty carbon steel.\* *These are not matters of maximum importance*, if only one can be sure of procuring the various grades of steel of uniform *known* qualities and be advised of the abilities of the respective grades of steel.

With a view to showing the extent to which the various grades of steel do differ in fact, even though the differences are not perceptible to the naked eye, some micro-photographs of the various steel products will be offered.

It is also true that the effect of *heat treatment* shows very clearly in the micro-photographs, as will be seen by an inspection of those offered for the purpose.

Fig. 1 shows the micro-photograph of a specimen of basic open hearth steel under the conditions, viz.:

Magnifications.....	350
Etched.....	deep
Heat treatment.....	{ Quenched at 950° C. Annealed at 550° C.
Metalloids.....	low
Carbon.....	0.35%

This is a very poor micro-photograph of a grade of steel that is far from desirable for use in crankshafts, which is what the steel was used for. It is not that the chemical composition

\*Thirty carbon steel! This is to express the carbon content, in points. One point is equal to one one-hundredth of one per cent., thus, 0.001%; hence one hundred points equal one per cent.; thus, 1.00%.

would be regarded as undesirable; for such is not the case. The fault lies in the *open* and non-silky nature of the appearance of the fracture. It is a question if basic open hearth steel will be nearly so good as the strictly acid fabrics, in any case; especially for crankshafts. The physical properties of basic (35 carbon) steel may be set down about as follows:

Tensile strength in pounds per square inch.....	78,500
Elastic limit in pounds per square inch.....	60,000
Elongation per cent in 8".....	25
Reduction of area, per cent.....	55

The above approximations will hold, only if the steel is well fabricated and is carefully heat treated in accord with the specifications. The same grade of steel in the normal state would probably show physical properties as follows:

35 CARBON BASIC O.H. STEEL (NORMAL)

Tensile strength in pounds per square inch.....	78,500
Elastic limit in pounds per square inch.....	28,500
Elongation per cent in 8".....	24
Reduction of area in per cent.....	54

The repair man is likely to use the steel in the normal state, with the result that *the repair will scarcely be permanent*. But it is also easy to see how the builder of the car may do the same thing, thus fully accounting for the need of repairs. Let us take this same 35 carbon steel and examine it from still another point of view; it is a product much used in automobile work; we cannot well know too much about it.

35 CARBON BASIC O. H. STEEL: TREATED

Tensile strength in pounds per square inch.....	130,000
Elastic limit in pounds per square inch.....	26,000
Elongation per cent. in 8".....	2.00
Reduction of area in per cent.....	4.50
Treatment:	Water quenched at 900° C.

Obviously the steel can be rendered as brittle as glass; it has a wide range of properties; the carbon contained renders the steel very susceptible of heat treatment; therefore, skill is essential to success in the use of any such fabrics. The fact that the steel is *basic* renders its treatment a matter of far greater



FIG. 2.

concern, since it is to the basic steel we owe much by way of inferior steel, due to the use of inferior ores. It might be said, the inferior qualities of this class of materials are being emphasized; not necessarily in repair work, which is the subject; if basic steel is the product that fails in a given part, some better grade of steel should be substituted.

To know what to do it is necessary to take into account the qualities of the product failing, that better products may be substituted if any

there are to be had. *A suspension bridge* of lead wire would not hold at all. Increasing the amount of lead would not solve the problem. *Use better material* for the purpose.

It is not to damn lead for its failure, it is to censure the user there for his lack of judgment! A great many people do not seem to see things in this way, but the users of automobiles do not see wherein it is for them to foot the bill if there is a basic mistake in its selection.

Nickel Steel and Its Peculiar Characteristics.

Fig. 2 shows a micro-photograph of a specimen of nickel steel, the data of which is as follows:

Magnifications.....	350
Etched.....	Deep.
Condition.....	Normal
Metalloids.....	Low
Carbon.....	.012
Process.....	Basic
Structure.....	Open

Surely, it would be a great mistake to pay ten cents per pound for such a product as this micro-photograph depicts. It has the name, but that is all. This is the class of steel that gives to the *genus*, nickel steel, the reputation it seems to labor under. True, this steel would be improved in appearance by *heat treatment*; equally true, a better grade of nickel steel would show far more improvement as a result of heat treatment. It is no license to use an inferior product, merely because heat treatment *might* mitigate against the evils of its composition, or the manner of its fabrication.

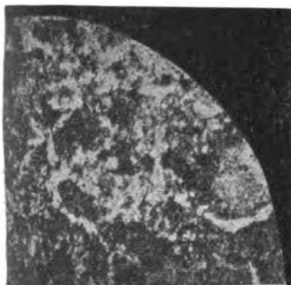

FIG. 3.

The fact that the metalloids are low is no criterion, since the ores of which steel is made are of the very inferior grades. If a part in a car fails, and it is of nickel steel, it may be of the grade of the same as here depicted; in which event it would scarcely be necessary to depart from the use of nickel steel in the replacement, if the replacement is of nickel steel of a truly good quality. Fig. 3 shows still another specimen of nickel steel, the data of which is as follows:

Magnifications.....	350
Etched.....	Medium
Condition.....	Annealed at 800° C.
Metalloids.....	Low
Carbon.....	28 points
Vanadium.....	0.18%
Chromium.....	1.00%
Process.....	Basic
Structure.....	Open

Crankshafts of such steel might be advertised as of nickel steel, but if they fail to thrive in service the repair man will be justified in looking about in quest of a better grade of nickel steel, rather than to conclude that nickel steel will not serve the purpose.

**As to the Failure of Nickel Steel.**

If the parts are of nickel steel, and the quality of the same is such as to warrant one in pronouncing it *standard*, then failure in service, under normal conditions, would indicate that a different *genera* of steel should be used in the repair. Unless, perchance, the original product was injured in treatment, or not treated at all. If it is plain that the nickel steel would only



FIG. 4.

end in further trouble, later on the only thing to do is to change to a grade of steel of improved characteristics. The next choice might be vanadium chrome steel; if by some means the same could be had of an assured quality. This is not a matter of certainty, because this class of steel is very new, little understood, in dispute, as to its relative virtues, and frequently the fabric of the basic open-hearth process. At all events, it will be well to see in a comparative way what such steel looks like, with a view to which the micro-photographs are here given. The first will be Fig. 4, the data of which is as follows:

Magnifications.....	350
Etched.....	Deep
Condition.....	Over heated
Metalloids.....	Low
Carbon.....	28 points
Vanadium.....	0.18%
Chromium.....	1.00%
Process.....	Basic
Structure.....	Crystalline

It would hardly be possible to find a piece of steel that would be worse for use in any part of an automobile than the steel in the condition as here depicted. It could be pointed out that the specimen was overheated, *on purpose*, to be able to observe its micro-structure; it can also be said it might not be easy to avoid this structure in practice. Fig. 5 is another vanadium chrome steel specimen, the data of which is as follows:

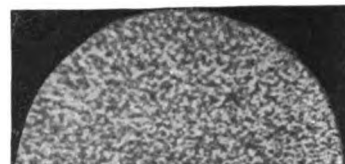

FIG. 5.

Magnifications.....	50
Etched.....	Light
Condition.....	Annealed at 800° C.
Metalloids.....	Low
Carbon.....	28 points
Vanadium.....	0.18%
Chromium.....	1.00%
Process.....	Basic
Structure.....	Uniform

To be able to observe the difference as between viewing the structure at low magnification and with the higher magnifications, Fig. 6 is given of the same grade of steel but with the higher power. Data of Fig. 6 (higher magnifications than Fig. 5):

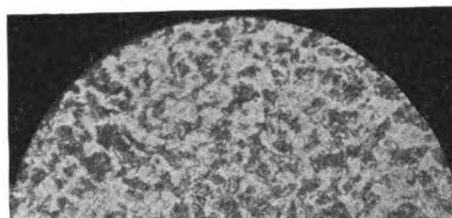

FIG. 6.

Magnifications.....	250
Etched.....	Light to medium
Condition.....	Annealed at 800° C.
Metalloids.....	Low
Carbon.....	28 points
Vanadium.....	0.18%
Chromium.....	1.00%
Process.....	Basic
Structure.....	Uniform

Since the structure is more plain at 250 diameters than at 50 diameters, it might be argued that to increase the magnifications to a very large extent would be beneficial; this is not necessarily true, since the detail is lost. Later on the author will show to what extent this may be so.

The degree of etching is a matter of some considerable moment that must not be overlooked, for if the etching is deep the appearance of the structure will not be the same as if the etching is light. Fig. 7 is given of the same steel, with a deep etching, and slightly greater magnifications, as follows:



FIG. 7.

Magnifications.....	350
Etching.....	Deep
Condition.....	Annealed at 800° C.
Metalloids.....	Low
Carbon.....	28 points
Vanadium.....	0.18%
Chromium.....	1.00%
Process.....	Basic
Structure.....	Uniform

(To be continued.)

## HOW THE AUTOMOBILE CHEAPENS DELIVERY SERVICE

**C**OMPARATIVE cost is undoubtedly the deciding point in any change from horse-drawn to motor delivery services. Business houses generally in all large and growing cities acknowledge the inadequacy of horse-drawn vehicles, and have to admit that at times of greatest stress the horse is least able to perform what is required of it. Two main difficulties have stood in the way of any changes, the first being the want of experience in the new field and the lack of accurate figures regarding cost of operation and upkeep of motor vehicles, and the second the lack of trained drivers at a marketable price. Users of horse vehicles know, or imagine they know, how much it costs to deliver goods by horse vehicles, but are utterly uninformed as to the cost by means of mechanical vehicles. Those who have made the experiment and have the cost of mechanical transportation at their finger tips in the majority of cases show no disposition to communicate them for the benefit of prospective users.

"We have an average of five letters a day," said the head of one large firm using motor vehicles exclusively, "all asking for figures on the cost of operation of our cars. It is impossible for us to reply to them all, and we have made it a rule to ignore every request. Besides, we have done the experimenting, taken whatever risk there was to be taken in the early days, and consider we have a claim to all the benefits."

If pushed back to hard facts and plain figures, it is generally found that the liveryman's knowledge of cost per mile is far from being as exact as would be expected after years of experience. While keeping close watch on all matters of expenditure and conducting his business as scientifically as the majority of those devoting their activities to the search for dollars, few business firms delivering goods by horse-drawn vehicles can state exactly how much they are paying per ton mile to deliver their products to customers.

Some figures in this connection which, though not showing the actual cost per mile, reveal the comparative cost of horse and automobile delivery service, have been obtained in actual use by the Logan Construction Company, of Chillicothe, O. For four successive days in November one of their air-cooled delivery wagons was substituted for the horse-driven force of a large business house and close watch kept of its expenditure.

On the first day the 20-horsepower air-cooled delivery wagon, with a rating of 1,500 pounds paying load and a pos-

sible speed of 15 miles an hour, replaced three wagons and delivered 210 parcels in a time of three hours. Fuel consumption was three gallons of gasoline and 1 1-2 pints of oil. Three wagons were displaced on the second day, and 155 parcels were delivered in 3 hours 45 minutes, with a consumption of 3 1-2 gallons of gasoline and 2 pints of oil. On the third day four wagons were displaced, and 439 parcels delivered in a total time of 4 hours and 45 minutes. Four and a half gallons of gasoline and 2 pints of oil were consumed on this day. On the fourth day four wagons were again displaced, 270 parcels delivered in 9 hours 15 minutes on a consumption of 9 gallons of gasoline and 2 pints of oil. This gives a total for the four days of 981 parcels, delivered in 20 hours 45 minutes, with a total consumption of 20 gallons of gasoline and 7 1-2 pints of oil. A greater initial outlay is called for with a mechanical service than for a horse-drawn force, but even deducting interest for the larger amount of capital invested, the saving is enormously greater for the automobile. Working the experiment out on a month's basis would give the following comparative result:

Cost of one 20-horsepower wagon.....	\$1,800	
Gasoline and oil.....	\$17.82	
Driver's wages.....	60.00	
Battery and repairs.....	6.00	
Tire wear.....	5.00	
	<u>\$88.82</u>	
Cost of three wagons.....		\$450.00
Cost of three horses.....		450.00
Harness.....		75.00
		<u>\$975.00</u>
Board, stabling and shoeing three horses.....	\$75.00	
Wages of three drivers.....	150.00	
Repairs, etc.....	15.00	
	<u>\$240.00</u>	
Cost of horse service.....	\$240.00	
Cost of automobile service.....	88.82	
Difference in favor of automobile.....	\$151.18	

This comparison of one automobile delivery wagon and its equivalent of three wagons, horses and crews, shows an initial investment of slightly more than double in the case of the former, but this is more than offset by the fact that the running expense under normal conditions would hardly exceed one-third. It must also be taken into consideration that when worked steadily day after day, the provision of three horses would not be sufficient to keep three wagons in constant service. At least four and sometimes five would be necessary, thus increasing their first cost.

## THE ADVANTAGES OF USING THE ENGINE AS A BRAKE

By C. F. REDDEN, STUDEBAKER AUTOMOBILE COMPANY.

**B**RAKING by means of the engine is at times particularly desirable, and it is surprising that more automobilists do not use this method. The regular set of brakes with which a car is equipped are, of course, sufficient to hold it on any decline. Yet, the continued use of the regular brake generates a large amount of heat, which not only wears the brake, but tends to burn it out.

The braking effect of the engine should not be used when it is required to stop suddenly. On a long, gradual descent a certain amount of braking effort is offered by the engine when the electric current is switched off. On a steeper descent the gears should be shifted to either low or intermediate, and the clutch will gradually let in.

In braking the car by means of the engine the greatest care must be used, and the car itself and the motor should be as nearly at the same speed as possible. The papers have

been filled with numbers of accidents, in which the cars have been reported to have gotten away. I have traveled, I believe, in my Studebaker over some of the worst and hilliest country roads in Westchester county, and I often take the precaution to shift into low speed before descending any particularly steep or dangerous hill.

Authorities seem to differ somewhat on what causes this braking effect, but the logical supposition is that it is caused by the compression of the gases in the cylinders. However this may be, the careful use of the engine as a brake is certainly to be encouraged. It has the good practical advantages of saving your own brakes for emergencies and sudden stops, and gives the motor time to stop and cool off, and all this is of considerable importance to the man who is trying to get the most out of his car. This not only means less expense, but less time in the hands of the repairman.

## CONCERNING GYROSCOPIC ACTION OF FLYWHEEL—A REPLY

By E. F. McNUTT.

ON page 75 of the January 16 issue of *THE AUTOMOBILE* appears an article by Rodger B. Whitman, entitled, "The Gyroscopic Action of a Flywheel," which sets forth the effects which such action has on the behavior of an automobile. While Mr. Whitman supports his claims by very substantial and convincing proofs, the conclusions which he draws from these proofs are not always entirely correct, nor does he take into consideration all of the factors which enter into the case.

Before taking up the discussion it would be well to state those two well-known laws which, as Mr. Whitman says, govern the gyroscopic action of a rotating body:

1.—If a rotating body be moved along an arc of a great circle, the axis of the rotating body will tend to revolve and assume a position parallel to the axis of the great circle and perpendicular to its plane of rotation.

2.—The axis will tend to assume a position such that the direction of rotation of the body will be the same as that of the great circle in which it is moved.

These laws have been proved by experiments and are beyond question. Taking up, then, the gyroscopic action of an automobile flywheel and its resulting influence on the action of the car, we will assume the average high-powered automobile, with its engine forward, its crankshaft horizontal and lengthwise of the car, and its flywheel turning over towards the left.

Taking first this car on a short, horizontal turn toward the left (which is the direction in which nearly all of the circular track races are run), let us see just what would be the result of the gyroscopic action of the flywheel. We have then in the flywheel a rotating body moved in an arc of a horizontal great circle, counter clockwise; by Law 1, as stated above, the axis of the flywheel will tend to assume a position perpendicular to this horizontal plane of rotation; and by Law 2 the position which it will tend to assume will be such that the flywheel will also rotate counter clockwise, tending to lift the rear wheels and thus destroying their traction. As Mr. Whitman says, such action in the case of a racing machine with a heavy flywheel, taking a sharp turn at high speed, might well result in a force which the weight of the machine could not hold in check; and besides this there are two other forces which tend towards the same effect. Mr. Whitman says: "Attempts to explain accidents to racing cars while rounding turns are often based on the assumption that the gyroscopic tendency of the flywheel will be to roll the car over, but that this is not the case may be deduced from the fact that a car rolling over sideways will be rotating in a vertical plane about a horizontal axis, and that as the axis of the flywheel is horizontal, it will remain in this position rather than tend to change it." That

this is not true in this case may be very easily shown. The rolling of the car due to the effects of centrifugal force would be over towards the outside of the curve, and the plane of this rotation would be vertical and transverse of the car. The flywheel would then tend to assume a position such that its axis would be perpendicular to this plane of rotation, and its direction of rotation the same as that of the rolling of the car, thus exactly reversing the position of its axis; and as the axis might rotate in either direction in a vertical plane parallel to the length of the car in order to assume this position, it would choose that of the least resistance, which would be that direction (over towards the front of the car) in which it tends to move, due to the horizontal turning of the car as explained above, thus adding to the force tending to lift the rear wheels from the ground; also this rolling, for obvious reasons, would concentrate the weight of the car on the two outer wheels, and through the forward motion of the car, partially arrested by the turning moment, most particularly on the outer front wheel.

So far I have agreed with Mr. Whitman that the real cause of accident to racing cars is due to loss of traction, and its resulting dangers, caused by the gyroscopic action of the flywheel; but now let us take the same car turning towards the right. The plane of rotation of the great circle would be horizontal and its direction of rotation would be clockwise, so that the flywheel would tend to assume a position with its axis vertical and its direction of rotation also clockwise, thus having a tendency to lift the front end of the car. But the effects of centrifugal force will also be felt here, and in this case they will oppose the tendency to lift the front wheels. The rolling of the car would be over towards the outside of the curve and in a plane transverse to the car so that the axis of the flywheel would be perpendicular to this plane, and the direction of rotation of the flywheel would be the same as that of the great circle, so that the flywheel would resist this force due to the turning of the car and would tend to maintain its position, thus tending to hold the car level, as would also be the result of the tendency to concentrate the weight of the car on the outer front wheel, the combined effect of these two forces being more than enough to counteract the tendency of the flywheel to raise the front end of the car.

Such, then, is the true explanation of the gyroscopic tendencies of an automobile flywheel and its resulting effects on the movements of the car. It is obvious that if races on circular tracks were run in a clockwise direction instead of following the horse, whose anatomy is equally efficient in either direction, around the track clockwise, many "unavoidable" accidents would be avoided and a much higher rate of speed maintained.

## SOME OF THE DEFECTS OF AUTOMOBILE SALESMANSHIP

By ERNEST COLER.

THE rapid development of the automobile industry no doubt is responsible for the present-day inefficiency of automobile salesmanship in that the dissemination of automobile knowledge, by the trade press and otherwise, has overtaken the educational process by which competent automobile salesmen are, or should be, made.

This is not a kind statement, to be sure, but it is based upon facts that should be clearly recognized so that they may be taken as a starting point from which wholesome reform is to proceed. A short time ago I had occasion to

discuss automobile selling methods with a friend, a mechanical engineer of keen observation and an experience including other fields besides that of the automobile, and the comments made by him brought automobile selling in so strong and unfavorable a contrast to the methods employed in standard engineering fields that the writer decided to make a close investigation, the results of which are given in the present article.

Were an acute observer to go down to New York's engineering district—Cortlandt or Liberty street—and then come



up to Gasoline Row on Broadway, he would discover the first distinction in the personnel of the selling force. The automobile salesman seems to be recruited from God knows where; his comprehension of the merits, and especially of the demerits of the product entrusted to his tender care, is hazy; his arguments for or against types of clutches, three or four-point suspension, shaft or chain drive, alloy steels, two or four-cycle, high or low-tension ignition systems, etc., have no depth, are meaningless, being hearsay arguments, devoid of actual knowledge. His superficial command of the demerits of his line renders him unable to meet properly the strictures made by the prospective customer, and he must, therefore, forego the opportunity to turn the weak points into apparent strong advantages.

Recruited from doubtful sources, how rarely does our automobile salesman attempt to strengthen his knowledge and fortify his position by close study of the standard literature and the leading periodicals of the trade? He glances over the pages, dallies over race meets, only when the day is stormy, when he is filled with ennui, tired of matching coins, flirting with the typewriter or running up the telephone bill. The repair shop, where he can learn things better than anywhere, he visits only in case of dire necessity; the mechanic in overalls is uncouth, therefore he has little dealing with him. The car itself on the streets only suggests joy rides, and the business is "the game."

Let us take a look at our cousin, the machinery salesman. It will do us good. He is an engineering-school graduate, perchance a graduate from the firm's draughting room, or a particularly keen mechanic, caught young and educated by the firm for its selling force. The salesman meets you with a slide rule; he has stacks of blueprints which *he can read*. You come there in search of a certain machine to do certain work. At first it seems that what you want is something special; but after studying your requirements the salesman educates you in his product; he will show you that his machine will do your work as you want it, but perhaps in a slightly different manner than you had anticipated. In the engineering field the purchaser is generally represented by his chief engineer, or by the master mechanic, and the salesman is actually instructing experts such as these. This selling system is the same for steam engines, pumps, gas engines, electric machinery, tools, etc. Imagine the high-salaried superintendent of a large machine works going to Liberty street to purchase certain machine tools, and have the salesman point out to him something quicker, more accurate, or cheaper, actually reviewing the operations gone through in the superintendent's factory to produce a given result, and then he will show him how in his own product a slight variation is more advantageous in results.

What would it be called in the automobile field if the sales manager were suddenly called upon to assume the position of chief engineer, as recently happened in a large hydraulic works; if the manager of a distant sales branch were called to the factory, to be the chief draughtsman, as in a big refrigerating-machinery plant; or if the chief inspector were sent to a Southern city to open and conduct a branch office.

as happened in a large gas-engine company but recently?

A statement was made a short time ago by a New England concern that this firm considered as its business the building of high-grade machinery, the body and furnishings to be considered auxiliary and to be adapted as much as possible to suit the ideas of the customer. Such a statement places the firm in the proper light, and were the selling force organized along similar lines this firm would be in the same class as builders of other engineering products.

The one example is the direct antithesis of the other. The engineering salesman knuckles down to be superior in specialized technical knowledge to his customer; if the latter is the purchaser of the backbone of the automobile trade, the great medium-priced car, he digs into its literature, subscribes to a couple of magazines, reads and digests them. In case of the high-priced machine, the chauffeur is consulted, and the (our) salesman keeps mum.

Will this state of affairs continue? Two causes will combine to change it—first, the increasing keenness of competition coupled with the growing automobile knowledge of the public; and, second—stronger than the first—the influx of the commercial vehicle. The first cause will operate by virtue of the fact that automobiles are approaching one another very closely in appearance, in reliability and in price. Purchasers no longer are falling all over themselves to get a car of some kind, satisfied if it has four wheels and some brass work; they demand that not only one trip but dozens of them be made without the necessity for adjustments, whereas, in the old days a trip without some mishap was unheard of. The commercial vehicle will demand a change because the purchaser will be represented by the superintendent of transportation, the chief engineer, or by a consulting engineer. Records will be kept of the car's performance, item by item; styles, fads and fancies, in ignition, transmission, etc., will play no part. Duplicate orders will be given only for cars that have stood the test, probably without even a visit to the salesroom. The argument likely to be advanced, that a certain system is popular in pleasure service will have little value for the commercial vehicle. Here our salesman will have to meet the quizzing of experts; any attempt to sidestep their questions will justly be frowned upon; not only will the purchaser be unfavorably impressed, but the engineering department will develop a tall-sized grouch if an attempt be made to pester it with the real work of the sales department—and pestered it will be if the commercial vehicle business ever becomes brisk. Then technical men will be detached from the engineering force to join the sales department. They will follow the performance of the vehicle *after* it is sold; they will come into close contact with the snags and difficulties of the service; they will analyze the successes and failures of certain features of their own as well as of other products. When, therefore, a new model is developed in the draughting room they will be called upon to go over the details, exactly as is done in other engineering works, with the result that the new model will have advantages that are absent in the machine not produced under such conditions.

## FARM HORSE GIVING WAY TO ITS RIVAL, THE AUTO

WASHINGTON, D. C., Feb. 17.—According to investigations made by G. K. Holmes, chief of the Division of Foreign Markets of the Department of Agriculture, the automobile has been responsible for the displacement of but 60,000 horses in this country up to the present time, and farm horses have never been in such great demand as at the present moment. In fact, the demand for horses for farm and other business uses has become stronger and stronger during

the past two or three years, the farm horses alone in use on January 1, 1908, numbering no less than 19,992,000 in round numbers. The department figures that 60,000 horses in stock on farms could have replaced the same number that have given way to the automobile, while it is calculated that the 500,000 horses which electricity displaced in urban street-car service, could have been replaced by 850,000 horses in stock assuming its growth to present proportions with horses.

## LETTERS INTERESTING AND INSTRUCTIVE

### ALCOHOL OR KEROSENE IN EMERGENCIES.

Editor THE AUTOMOBILE:

[1,168.]—Kindly let me know, through "Letters Interesting and Instructive," how a gasoline car could be run on alcohol or coal oil. Last Sunday I was stuck for want of gasoline, but could have had coal oil or alcohol, but did not know how to use it.

Philadelphia, Pa.

H. R. McKAY.

Either kerosene or alcohol may be used in a gasoline motor in an emergency with but little difficulty. This is the case particularly when the lack of gasoline is discovered before the motor has been allowed to get cold. The emergency fuel may be poured into the tank and the motor, either kept running continuously or started with but little trouble. It is advisable to cover part of the radiator or cut down the efficiency of the cooling system in some equally simple manner in order to raise the temperature of the jacket water and maintain it just short of the boiling point. Otherwise there will be a noticeable lack of power with either alcohol or kerosene. For starting from cold, it will doubtless be found necessary to warm the carbureter by swathing it in rags dipped in boiling water, as neither of the fuels in question will vaporize at ordinary temperatures. It will also be found necessary to increase the amount of lubricant employed to run the same distance, owing to the fact of the introduction of a greater or less quantity of liquid fuel into the cylinder, and the consequent cutting of the film of lubricant on the cylinder walls. Considerably more fuel will be necessary with either of these fuels than with gasoline, and even under the best conditions obtainable with a car on the road it will scarcely be found possible to get as much power as with gasoline; but by heating the carbureter and raising the running temperature considerably, it should always be possible to get home.

### DIRECTIONS FOR ADJUSTING A CARBURETER.

Editor THE AUTOMOBILE:

[1,169.]—Will you kindly inform me through the columns of "The Automobile" if my system of adjusting a carbureter that has been completely taken apart would be best, and if not, please advise me: To adjust carbureter, close throttle and retard spark. then adjust gasoline needle till engine regains its highest speed; after this, open throttle with spark still retarded and adjust air valve till the best result from the open throttle is obtained.

Worcester, N. Y.

OMER SLOAT.

We believe it is the consensus of opinion of both carbureter makers and repairmen that the correct method of making a carbureter adjustment of this kind is to regulate the gasoline supply until the motor can be started on it. Then with the motor running, the gasoline is decreased until the motor reaches the lowest speed at which it will run regularly and without missing, the occurrence of the spark being retarded to suit the speed of the motor. The throttle should then be opened and the spark advanced with it, and if the motor fails to run as it should at the higher speeds, an attempt should be made to remedy matters by altering the auxiliary air adjustment so as to allow more or less additional air as the case seems to demand. This method of adjusting is followed on the theory that with a sufficient supply of fuel at low speeds the increased suction of the motor will take care of this essential as the speed increases, and a good mixture will be formed if the air adjustment is correctly made. Probably many autoists have adopted satisfactory methods of their own by doing this, as a result of experience, and their way of accomplishing this most important of adjustments would doubtless be of considerable interest to the rest of their fellows not so fortunately situated, so that we should like to hear from those who have methods of their own, which will be published in this department.

### EXAMINING SECOND-HAND CAR CRITICALLY.

Editor THE AUTOMOBILE:

[1,170.]—Will you give in an early issue of "The Automobile" instructions as to how to examine a second-hand automobile (besides a demonstration), which will enable one of moderate mechanical ability to detect weak points likely to soon need repair and determine truly the general condition of the car, and especially of the mechanism and tires; in other words, guiding advice to prospective purchasers of second-hand cars.

Does an air-cooled motor consume more lubricating oil than same size of water-cooled motor, having the same number of cylinders? If so, is there much difference, and to what cause is it due?

A. C.

Pleasant Lake, Ind.

In the purchase of a car that has seen service there are a great many things to be taken into consideration, so that they can only be dwelt upon briefly here. Have the engine run at all speeds while standing and note carefully whether it gives audible sounds of derangement, such as knocking, missing and other miscellaneous sounds of loose or badly worn moving parts, or visible signs of distress such as the escape of smoke from exhaust manifold, water, oil, or gasoline leaks. Many of these may proceed from causes small in themselves, but requiring considerable work to overhaul and make good when taken in the aggregate. A bad knock may only mean lack of adjustment of the bearings, but it is more apt to indicate the necessity of their renewal. A water leak may come from the radiator and prove expensive to repair, and escaping smoke may really come from a cracked valve-port instead of the manifold. The former would be a serious defect, while the latter would only require new asbestos gaskets to remedy. Gasoline and oil leaks may likewise be either trivial or serious according to their cause. The outside appearance of the car should be noted, as this will give some indication of the manner in which its owner has treated it. If it should show the marks of numerous collisions on fenders, hubs and other protruding parts, it is safe to say that it has been recklessly driven and probably not any better taken care of.

After satisfying yourself that there is nothing seriously wrong about the motor or any of its accessories, examine the transmission, step by step. First, the clutch. If this be of the leather-faced conical type, the need for a new facing is not a serious defect, but as many early clutches of this type were poorly designed, it should be looked into thoroughly. Note whether the leather is burned, whether excessive spring pressure is required to seat the clutch, and whether the clutch shaft appears to be in any way sprung, or out of alignment. Open the gear-box and flush the pinions a bit with gasoline so as to be able to observe the condition of their teeth. Mangled and battered gears are a sign of poor material, poor driving, or both, and as they are expensive to replace, a car on which this defect is prominent would not be an extra good investment. Both the clutch and gear-set in the average car are quite accessible, and no owner who honestly believes his car to be in good condition can possibly object to a thorough examination of these vital parts. See that the shafts are absolutely true, and to do this run the motor with the gear-box open. If the shafts wobble, they are not in line, and their bearings should be examined. Stop the motor and try shifting the gears to each position; the cause of any difficulty in doing this should be ascertained before going further.

It will be found a good idea to take a pad and pencil, and as each defect is found, make a note of it, totalling them at the conclusion of the examination and estimating the cost of making them good. The owner will, of course, belittle them in every instance, and assure the prospective purchaser that

they can be made good for a mere nothing—"a few dollars will do the whole thing;" but if the purchaser be not able to estimate the repairs himself, he should take not alone the advice of a repairman, but get a close estimate of what the latter will do the work for. It is well to call in a disinterested repairman. Coming back to the examination, see that the gear-set housing does not leak oil, and that the aluminum is not cracked around the bearing seats. Proceeding further, see that the universals on a shaft-driven car are not badly worn. Look to the chains on a car of that type, also the sprockets. Jack up the rear axle, open the differential case—there is usually a hand-hole plate easily removable, so do not be deterred from examining such parts through the disinclination of the seller to show them "on account of the trouble." Have some one turn the rear wheels for you while you watch the differential pinions and the main bevel and driving bevel pinions for wear or broken teeth. With both rear wheels jacked up, run the motor and try shifting the gears to every speed, including the reverse. Note the running of the differential, and then stand off to the rear and note how the rear wheels run. If they wobble at all, and weakness of the rear-axle driving unit has been a characteristic of many low-priced cars during the past few years, it is an indication that the driving shafts of the rear-axle are sprung, the differential is out of line or something of that nature—in any event, an expensive item to make good.

Examine the axles closely for dents or other indications of the effects of a collision, and look closely into the manner in which the springs have stood up. If they have been overburdened and have taken an excessive permanent set, they are apt to break at any time. Comparing their appearance with those of a new car is probably the easiest method for a layman to detect anything wrong with their appearance. Look into the steering closely—some looseness is inevitable, but there should not be an amount of play that would render it dangerous as being apt to give way at any moment. Also examine all steering gear connections minutely, particularly the drag-link. Take hold of the wheels and try to shake them laterally to detect looseness on their bearings. No matter how close this examination has been, insist upon having a long demonstration. Many cars can be made to run around the block or for a mile or two, without revealing anything wrong, but they are apt to prove their real condition on a good day's run. It will be found a good investment to offer to pay for the fuel and other expenses of making such a demonstration, whether the sale be consummated or not. Any owner will realize the justice of such a proposal.

An air-cooled motor consumes more lubricating oil than a water-cooled type, due to the higher average temperature of operation. The difference depends entirely upon the make of the two motors. The accusation has been made against some air-cooled motors that they are "oil-cooled," but ordinarily the difference in this respect is not great enough to be put down as a disadvantage.

### LIQUID GASOLINE IN THE MANIFOLD.

Editor THE AUTOMOBILE:

[1,171.]—Will you kindly explain, in the columns of your paper, why liquid gasoline can be seen swimming down the pipe that leads from the carbureter to the intake pipe on my four-cylinder, 30-horsepower car, fitted with a Schebler carbureter? Is there any way of adjusting the float on said carbureter? If so, where?  
Colon, Neb.

A SUBSCRIBER.

It is evident that either the float is too high or the opening of the nozzle is too great for the requirements of the motor, or it may be that both troubles are present. Theoretically, liquid gasoline should never get beyond the carbureter and into the intake manifold, though under certain conditions more or less either finds its way there or becomes transformed into that form by condensation, but any such amount of liquid that would justify the term "swimming," would seem

to point to very defective adjustment. If you will write the makers of the Schebler carbureter they will forward you a comprehensive book of instructions on its use and adjustment, which will serve your purpose much better than the necessarily limited amount of space that could be devoted to it here. Such a book takes up each part of the carbureter, describing it and its functions in detail, and exactly the manner of making all the adjustments.

### TO THE AID OF TWO INQUIRERS.

Editor THE AUTOMOBILE:

[1,172.]—In your publication of December 30, I notice a communication, No. 1,136, signed "A Subscriber, Oakland, Cal.," who complains of trouble which he had relative to his machine, which was a four-cylinder engine with automatic intake valves, knocking when under load.

I have had some difficulty with the same style of machine, using a Schebler carbureter, and, I imagine from his description, the same engine.

After exhausting every method to locate the cause of trouble, I have succeeded in obviating the entire difficulty by changing the carbureter. I believe the Schebler carbureter is a remarkably good one, but possibly not adapted to some styles of engines as well as a larger carbureter, and if you will take the trouble to forward to the writer of the inquiry this communication I shall be pleased to advise him the methods which I followed in locating the trouble and correcting it.

I would also say in reply to inquiry No. 1,142, of February 6, by J. H. Townsend, of Danbury, Conn., I have advised him that the Buckmobile was manufactured in Utica, N. Y., and the concern manufacturing it has been out of business for some time, but I am also advised that parts may be purchased from some person in Syracuse, N. Y., the exact location of which I shall be pleased to ascertain should other inquiries follow.  
J. T. DURHAM.  
Oneida, N. Y.

Editor THE AUTOMOBILE:

[1,173.]—I notice in your issue of February 6 an inquiry, No. 1,142, signed J. Townsend, Danbury, Conn., who wants to know who built the Buckmobile. You answered his inquiry by saying that you didn't know their address. The Buckmobile was built in Utica, N. Y., by the Black Diamond Automobile Company, and the factory was located on Upper Genesee street. The company is now out of business, but the people interested are Mr. Brower, William Birdsall, now with the Mora Motor Car Company, and A. J. Seaton. Mr. Seaton and Mr. Brower are still in Utica.

IMPERIAL MOTOR CAR COMPANY,

Williamsport, Pa. Fred P. Brand, Vice-Pres. and Gen. Mgr.

The following have also come to the rescue of Mr. Townsend on the Buckmobile question, but as their letters contain the same information in greater or less detail, it is unnecessary to publish them here in full. They are:

Philip A. Clum, Clum & Atkinson, Rochester, N. Y.  
C. B. Hine, Curtis & Hine, Colorado Springs, Col.  
D. C. Austin, Newark, N. J.

### CONCERNING THE TIMING OF A MAGNETO.

Editor THE AUTOMOBILE:

[1,174.]—Kindly advise me if possible, as to the dates of the various publications of your paper which have technical articles bearing upon the action and construction of magnetos. I find that most publications on ignition, while going thoroughly into the question of volts and amperes and Ohm's Law, jump at once to induced and self-induced currents, without proper explanation.

Kindly advise me also on the following points:

1. Why cannot a low-tension magneto giving an output of 6 volts at 1,500 r.p.m. with the aid of an induction coil and trembler, be used on a jump spark? In your issue of December 19, 1907, under the heading, "Why an L. T. Magneto Must Be Timed" (No. 1,025), you say that the magneto generates an alternating current, and must be properly timed by gearing. How does such a magneto differ from an L. T. Hendricks magneto, giving 6 volts at 1,500 r.p.m., with the aid of a primary spark coil, that I am using on a make and break circuit for a three-horsepower, two-cycle engine, the drive being by friction wheel from engine flywheel, and which is certainly not timed?  
JAMES W. MYER.  
New York City.

In view of what you state in the first part of your inquiry, few of the articles published on the subject of magnetos in

THE AUTOMOBILE would be of any great assistance to you, and we should recommend you to invest in an elementary work on electricity, as you will realize it is out of the question to begin with the rudiments every time it is necessary to explain something of this kind.

Because, at this speed, there would be such an appreciable length of time between the current impulses that it would be quite possible for them to occur between the intervals of spark timing, instead of when wanted, with a consequent failure of ignition. It must be borne in mind that the type of magneto commonly employed for automobile ignition has a simple "H"-shaped armature and a two-pole field, so that it only generates two impulses per revolution, from which it will be evident that it would be necessary to run it at a very much higher rate of speed than 1,500 r. p. m. in order to insure having sufficient current at the proper moment to ignite a high-speed engine. In fact, the number of cycles, or alternations of the current, would have to be almost as high as that used for incandescent lighting, *i. e.*, 65 to 125 per second, so as to obviate the possibility of a dead point of the armature revolution corresponding with the firing point of one of the cylinders. The need for doing this is eliminated by timing the magneto to the engine, thus utilizing its two comparatively widely separated impulses to the best effect.

Such a magneto differs from what you term a magneto altogether, in that the machine you have is really not a magneto at all. It is simply a small direct-current generator with a permanent magnetic field instead of the usual electromagnetic field employed on dynamos. It does not generate an alternating current, but a direct current, and there is no reason why it cannot be used with an induction coil and spark plugs for jump spark work, except that it will be necessary to closely regulate the generator speed on an auto.

#### QUESTIONS CONCERNING POWER AND TIRES.

Editor THE AUTOMOBILE:

[1,175.]—Will you kindly answer the two following questions through "Letters Interesting and Instructive":

1. I have a Winton Model K and would like to know if I could get more power by mixing kerosene with gasoline, and if so, what is the proportion?

2. Can you tell me how much of a load a 34 by 4 tire should carry?  
N. F. R.

1. It might be possible to obtain greater power by using a mixture of kerosene and gasoline, rather than the latter alone, but we doubt if this would be the case where such a mixture is employed in a motor designed primarily to be run on gasoline alone and fitted particularly for that fuel. Kerosene has slightly more heating value than gasoline, but a higher initial compression and a longer stroke are required to fully take advantage of it. You might reduce your fuel bill somewhat by using a mixture of half kerosene and half gasoline, or one-quarter of the first and three-quarters of the latter, but in any case we doubt very much if there would be any appreciable difference in the amount of power developed.

2. The permissible load of 34 by 4-inch tire is 700 pounds per wheel, as agreed upon by the tire manufacturers two years ago. It is needless to add that this is far more often exceeded in practice than otherwise.

#### WHAT CAUSES THIS MOTOR TO MISS?

Editor THE AUTOMOBILE:

[1,176.]—Will you kindly answer the following questions: Why does my motor miss explosions after starting in the morning until it has run about ten minutes? It is a 50-horsepower four-cylinder engine. Would an induction coil increase the power of the motor with low-tension, make and break ignition?  
L. A. H.  
Jacksonville, Fla.

Some motors will frequently do this until they have run long enough to warm up. It is probably caused by the fact that either the carbureter is not adjusted to furnish a readily explosive mixture until it becomes warm, or it is incapable of

working well when cold. An induction coil could not be employed in connection with a low-tension system. You may have reference to a common "spark" coil, which is a single winding on a heavy iron core. This will increase the size and intensity of the spark made by a low-tension igniter and might improve matters where the current now obtainable is weak.

#### BUSINESS METHOD OF FIGURING COSTS.

Editor THE AUTOMOBILE:

[1,177.]—Your "Letters Interesting and Instructive" often chronicle low costs per mile for the operation of the automobile, and it has often occurred to the writer that the reading public may be misled by the figures presented. There is no doubt but what the actual fuel expense and repair costs of upkeep are in some instances *very*, mild, and to those who are fortunate enough to be numbered with the lucky squad the figures tell a very gratifying story.

There may be many others who will agree with the writer in the following schedule of expense, and it would be pleasing to see opinions quoted and compared, at least to the writer, and possibly to other readers of your valuable journal.

Would not a very equitable plan, in figuring the cost of keeping an auto include properly the following expenses:

First.—Interest upon the original investment for the full period of ownership, first cost to include price of all accessories.

Second.—Actual depreciation of the machine, never correctly determined until the machine is sold.

Third.—Stable hire, or garage rent, by the month or other period, for even those of us who own our own stables should pay ourselves rent.

Fourth.—Fire insurance. Is it safe to be without it?

Fifth.—Accident insurance. Apply the same question as above.

Sixth.—Necessary replacements, for no car will run indefinitely without care and renewed parts occasionally.

Seventh.—Shop charges for repairs not solvable to the ordinary mechanic.

And lastly—The, often estimated, quantity of fuel and lubricant used. Does not the last item become really a minor consideration in the keeping of a machine, and would a better standard to go by be the cost per year to run a machine, rather than the cost per mile, for divide all the costs by a low mileage and the result will astonish a driver, while a large mileage would be affected by practically the last item only, other numbers being in the line of fixed charges.

No account has been taken of costs of entertainment, as that should be returned in kind some day, and the writer assumes that an owner who cares to figure the expense drives his own car.

Lawrence, Mass.

A CONSTANT READER.

#### PAINTING ALUMINUM FOOTBOARDS.

Editor THE AUTOMOBILE:

[1,178.]—I have worked out a kink in the care of a car which I think may prove of interest to fellow automobile users, so I am sending it for publication in "Letters Interesting and Instructive," if you consider it merits a place there. The use of cast aluminum with a roughened surface has become so common for footboards, toeboards, running boards, etc., as to make its maintenance in bright condition somewhat of a problem for the owner who already has enough of trouble in the way of brass to be polished, paint to be washed, etc. When new, the aluminum looks fine, with a satiny finish that appeals to all, but once it has been splashed over a little with oil and then exposed to dust and muddy feet, it is practically impossible to clean it up again to look like new, its roughened and somewhat absorbent surface clinging to the dirt past the ability of any ordinary ingenuity to remove it. Confronted with this condition, I tried the experiment of painting the surfaces with a solid coat of good coach varnish, of a color that harmonized with that of the rest of the car. Then, with a sheet of sandpaper wrapped about a block of wood, I took off all the paint from the smooth edges and high points, leaving these exposed and easily reached portions in bright aluminum, while the less-exposed portions remained coated with the easily washed paint. In the matter of appearance, I consider that the pattern worked out by the alternation of the bright aluminum points and edges with the darker painted areas will appeal quite as generally as the unrelieved aluminum surface.  
LEO JOELSON, M.D.

Houston, Tex.

#### ABOUT HIGH-TENSION IGNITION VOLTAGE.

Editor THE AUTOMOBILE:

[1,179.]—In question No. 1,029, Mr. Ellis wishes to know at what voltage the spark is given in the cylinder. The question seems to be of considerable interest to many. I have heard as many different



answers as questions, and the answers run from 10,000 to 100,000 volts, the last from your magazine. As we cannot get something from nothing, let us look to our supply of electricity for this excessive voltage. If we had 10 amperes of electricity at 1 volt, we could transform it with a suitable induction coil to one ampere at 10 volts or 1-2 ampere at 20 volts. What we gain in voltage or pressure of current we lose in amperage or quality. Now we know that we can take 6 cells that show 4 amperes each, and by connecting them in series we get approximately 9 volts, but this gives a total amperage for the 6 cells of 4 amperes. Now, if we should transform these 4 amperes to 100,000 volts, this would give us but 1-25,000 of an ampere to make a continued spark for a minute or so, as these six cells will do in actual operation.

As an ampere represents a volume of a current produced by a pressure of one volt, flowing through a conductor having a resistance of one ohm, the above current could only pass through a wire having the resistance of 1-25,000 of an ohm. There is only one way to find the truth of this matter, and that is to get a coil maker to tell us what are the proportions in his windings in the primary and secondary coils, and then we could figure it out ourselves.

I want to say a word in regard to Mr. Fay's assertion that a carbureter should not have a needle point in the spray nozzle. For the last three years I have never adjusted my carbureter, for the simple reason that I couldn't if I wanted to, as there is no needle point in the nozzle, and if all parts of my automobile were as perfect as this one part, all would go well indeed. I think a carbureter with a needle point would be on par with a man buying boots too large and then pulling on three or four pairs of stockings to make them fit.

FRED C. HATHAWAY.

Portland, Mich.

### TIMING AND SCAVENGING AT HIGH SPEEDS.

Editor THE AUTOMOBILE:

[1,180.]—Referring to the final paragraph of C. T. Bates' letter, in your issue of February 6, I venture to say that if Mr. Bates will read again what I said about spark timing at high speeds, and read it slowly, he will fail to find any intimation that complete ignition of the mixture can be obtained at the instant which would give maximum effect, when running at very high speeds. What I said was that timing the spark is no more difficult at high than at low speeds, and I was careful to explain that beyond a certain speed it is not practicable to advance the timing far enough to secure combustion at the most efficient moment. The most efficient timing is not practicable simply because it entails beginning combustion so far ahead of the dead center position as to produce dangerous back pressures, and not because of any difficulty in setting the timer at the proper point, as Mr. Fay's statement clearly intimated.

In my letter, on page 181 of your issue of February 6, a line is omitted and the effect of a statement thereby impaired. After the fifth line from the top of the second column should be inserted the line:

"but this critical point usually occurs near or beyond the maximum speed."

CECIL P. POOLE.

New York City.

### HELP ON THE LUBRICATION QUESTION.

Editor THE AUTOMOBILE:

[1,181.]—I have obtained a great deal of useful and helpful information in your "Letters Interesting and Instructive," and as one good turn deserves another, I will give my experience with a Ford Model N runabout. Formerly I had lots of trouble with my spark plugs sooting up. I frequently cleaned one or more plugs two or three times a day. I don't do that any more—do not have to—have not looked at a plug for the past three months. Let me explain: I now pour kerosene, lubricating oil, either or both, in any quantities from a pint to a couple of quarts of cylinder oil, right into the crankcase, but when I have done that I also pour a cupful—4 to 6 ounces—of "radium decarbonizer" right into the crankcase, start up the engine, and away I go, with never a miss from foul plugs. My muffler I find to be clean and the engine with splendid compression and increased power. This is in no way an "ad" for anybody. I pay for what I get, and I only write these lines for the benefit of others, who, like myself, are afraid to pour oil freely into the case. Now I do as Ford says, pour in plenty oil, and then some more, and then lots of oil; no matter how she smokes, the plugs will stay clean.

J. L. WILLIAMSON, M.D.

Milwaukee, Wis.

### INFORMATION WANTED ABOUT "MAGNALIUM."

Editor THE AUTOMOBILE:

[1,182.]—On several occasions recently I have come across references in different trade papers to an alloy termed "magnalium." It is, as I understand, an alloy of aluminum and magnesium, and is, because of the specific gravity of the second component, even lighter than aluminum, while it is claimed to possess altogether

superior physical properties. I do not know that it is extensively applied to any purpose, except for making beams for fine analytical balances, and it is apparently so new that I am able to secure only the most meager information concerning it. For this reason I am writing to learn what I can about its physical properties, etc. I will greatly appreciate it if you can tell me by whom and when this alloy was first used, where it can be secured and the cost, its specific gravity, its tensile strength, character of fracture, melting point, capacity for forming by founding, hammering, and machining, and its appearance and resistance to corrosion. I particularly wish to know about the latter point, because pure magnesium is well known to oxidize quickly to magnesia if exposed to moist air.

Madera, Cal.

GEORGE WAINWRIGHT.

### HELPING OUT TWO OTHER INQUIRERS.

Editor THE AUTOMOBILE:

[1,183.]—In answer to Nos. 1,136 and 1,137 of your "Letters Interesting and Instructive," let me give you my answers.

Inquiry No. 1,136: I had the same trouble on my four-cycle engine, and after a great deal of trouble, looking and worrying, I found that the connecting rod was loose at the wrist; i.e., in the piston end of the rod. The questioner will very probably find the same cause for the "knock."

Inquiry No. 1,137: I will say he can use his engine as a brake O. K. with the throttle closed and ignition off. If the descent is too steep, change to a lower gear. If the inquirer will get on a long hill and then cut out the ignition, he can experiment for himself with the throttle; but he will find it as the editor suggests; i.e., keep the throttle closed and save fuel as well as get more braking power out of the engine.

Allegan, Mich.

SCHUYLER G. FOSTER.

### NECESSARY TO WARM THE CARBURETER.

Editor THE AUTOMOBILE:

[1,184.]—Regarding letter, No. 1,135 in "Letters Interesting and Instructive," you say there is no need of heating the air or carbureter. There is, and the warmer the air and the warmer the carbureter is kept, the more economical and efficient the engine will be. Why are all the leading carbureter companies water-jacketing their carbureters?

Regarding letter No. 1,136. Have had some trouble with a Louis two-cycle engine, but found it was lack of lubricant. Engine would run fine as long as I kept the oil so high in the crankcase as to cause the engine to smoke. It was a water-cooled engine.

Chicago, Ill.

C. S. VIALI.

### MORE ABOUT BRAKING WITH THE MOTOR.

Editor THE AUTOMOBILE:

[1,185.]—After reading letter No. 1,137 in your issue of January 30, relative to using motor for braking purposes, it may interest some of your readers to know that a very satisfactory device of this kind can be had in the open market. I have used this device with very gratifying results. It consists of an auxiliary air and ignition cut-out valve located directly under the steering wheel, which when opened admits cold air to the induction pipe ahead of carbureter, and at the same time cuts out the ignition. I have found the saving in one season of fuel, brake bands and batteries amounted to many times the first cost, not to mention the great amount of added comfort and convenience in the handling of the car obtained by the use of the device.

Wollaston, Mass.

FRANK T. CABLE.

### ONE WAY OF MAKING DRY CELLS OVER.

Editor THE AUTOMOBILE:

[1,186.]—Where dry batteries retail from 40 to 60 cents, it pays to rejuvenate your old ones. To do so, cut the old zincs off, being careful not to disturb the manganese filling, then wind tightly with two or three layers of blotting paper, then wrap with linen thread to hold in place, then slip a new zinc over, leaving the long joint unsoldered; then wrap this tight with a piece of wire, solder the joints, and take off the wire; then soak it from the top with a strong solution of sal ammoniac or ammonia chloride and seal, and it has got a new lease of life. This can be done at a trifling expense, and the fillings will stand the operation two or three times.

Redding, Cal.

A BATTERY FIEND.

### SOME CORRECTIONS FOR LETTER NO. 1150.

Editor THE AUTOMOBILE:

[1,187.]—Referring to letter No. 1,150 in the issue of January 30, I beg to say that I wrote possible "relations," not "solutions," and "Type 1," not "Type 2."

East Acton, Mass.

CHARLES J. WILLIAMS.

**TO SUPPLANT STEAM ON PRAIRIES.**

Nothing but the steam traction engine and improved agricultural machinery made the vast farms of the western plains a possibility, but it would seem that the day of the steam tractor is now drawing to a close, and that its place will shortly be taken by the far lighter and more economical gasoline-driven machine. A concern known as the Farmobile Company has devised a special machine to take care of practically all the power needs on these large farms. Its manufacture has been taken up by the Oscar Lear Automobile Company, Springfield, Ohio, and it is probable that the latter firm will build these farm machines in numbers. For plowing and similar work the Farmobile works on a novel principle that insures the efficient utilization of every bit of its power, regardless of the nature of the ground. The machine gets its traction from a 7-16-inch steel cable, stretching the entire length of the field and anchored at one end by means of a pulley block, which rides on a 1-2-inch cable at right angles to the main cable, 200 feet long, and which is anchored to 6-inch posts, set 200 feet apart.

On the machine itself are large drums or capstans, round which the main cable takes six turns, or wraps, and passes out to the rear. These capstans are arranged to be propelled directly by the engine, and when turned in this manner the machine advances along the cable, drawing a load which would require twenty strong horses to haul, and at a speed of 2 1-2 miles an hour. The main cable, riding on the transverse cable at the end of the field, allows of a strip 200 feet wide being worked the entire length of the field without shifting the cable. When such a strip has been completed the end cable is unlooped from the first post and put over a third, and then the machine is in a position to work a second 200-foot trip. Under favorable conditions the machine will plow 12 furrows at a time and will average 35 acres per day of 10 hours. The cable system also provides an ideal method of pulling stumps, lifting very heavy weights, and the like, and with its aid a farm can be worked practically without the use of horses.

It is also designed to be used for traction purposes, and can make a speed of four miles an hour on the road when hauling its maximum load in the shape of a train of wagons.

It is also adapted to be used for cultivating, or the engine can be run free and its power utilized, by means of the large belt pulley provided, to run stationary farm machinery, pumps, or for similar purposes. The power plant consists of a Frayer-Miller air-cooled engine mounted transversely across the frame of the machine, both the ignition and throttle being controlled by a centrifugal governor, so that the driver is left free to watch the steering and tend to the plows, his seat being so placed that he has full control over

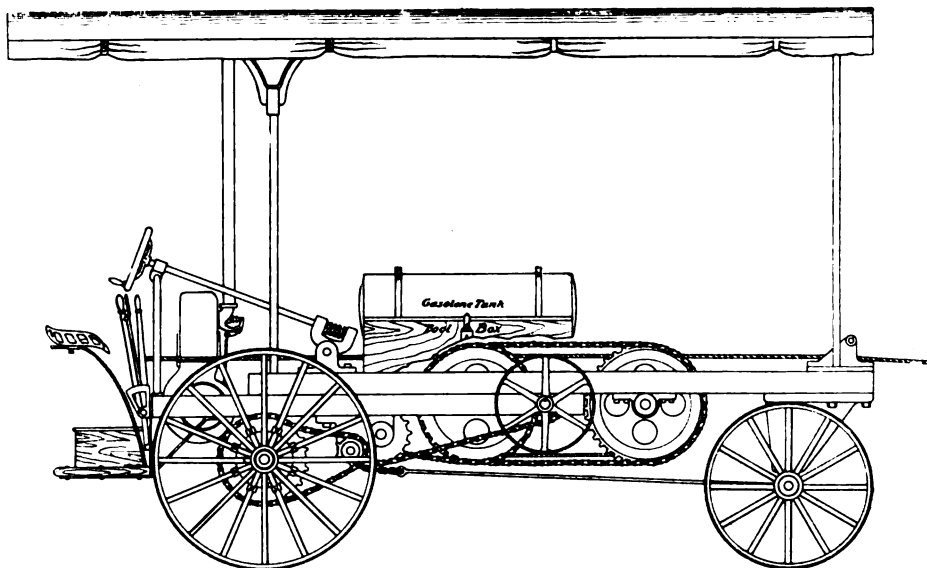

SIDE ELEVATION OF THE FARMOBILE, SHOWING ARRANGEMENT OF DRIVING GEAR.

the machine as well as whatever it is hauling. The control of the machine itself is by means of a steering wheel and two levers. Three sizes of the machine are to be built, equipped with 20, 35 and 50 horsepower Frayer-Miller air-cooled motors, respectively. They will weigh in the neighborhood of 3,500 pounds and will sell for approximately \$1,500, \$2,000 and \$2,500. The use of such machines in the western part of the country, with alcohol as a fuel, would provide a great impetus to the further introduction of machinery for farm use, as in such regions the cost of coal, wood and gasoline is practically prohibitive. Since the machine shown by the accompanying photograph, together with its work, was built, the driver's seat has been changed as shown by the line sketch illustrating a Model A Farmobile.

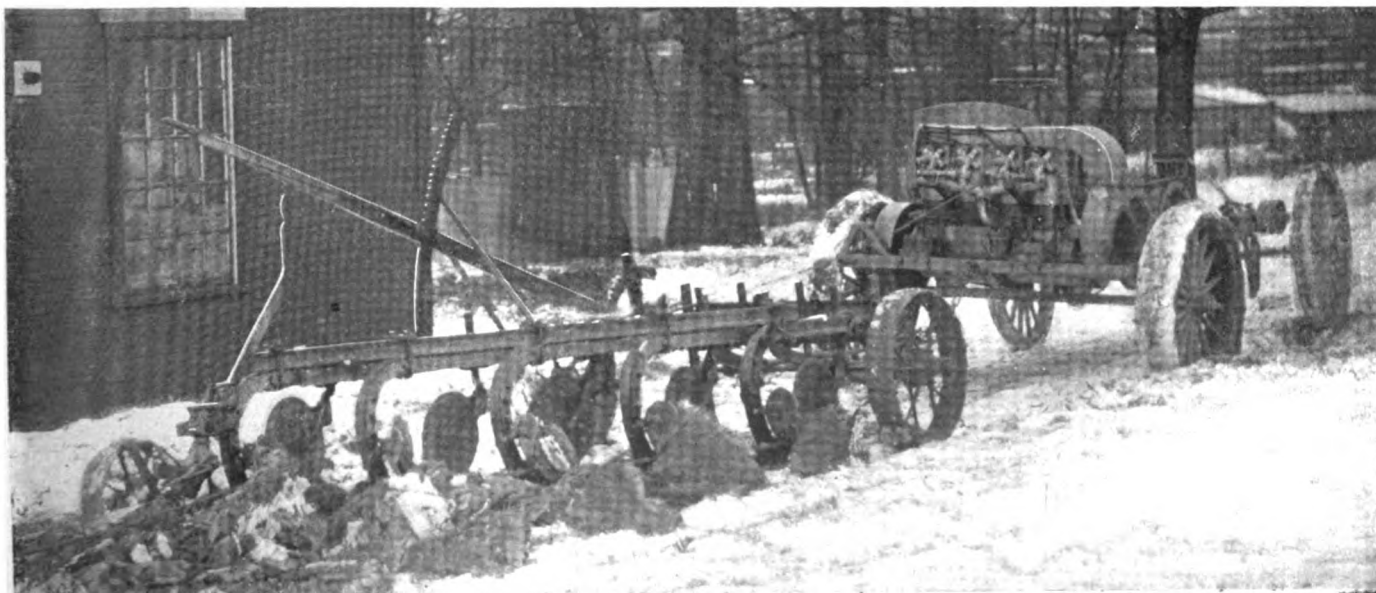

THE FRAYER-MILLER FARMOBILE PULLING FIVE PLOWS IN FROZEN GROUND NOT BROKEN PREVIOUSLY IN 25 YEARS

**NOVEL AUTOMATIC GEAR-SHIFTER.**

Numerous attempts have been made to solve the problem of lessening the driver's work of gear-shifting, as well as the disadvantages to a great extent, by providing the car with an automatic device to accomplish this end. An ingenious arrangement of this kind has been invented by Thomas Burton Ford, on which a patent has recently been granted. The illustration shows a side elevation of the device as applied to

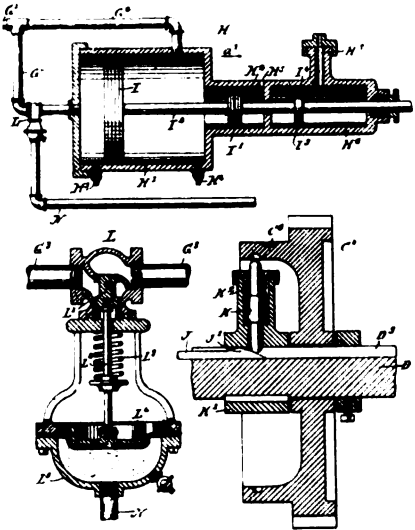

DETAILS OF CYLINDER AND DIAPHRAGM.

a car, the force employed being compressed air, the action of which is automatically controlled by the speed of the car and of the engine. Two air pumps are provided, one run by the engine and the other by the rear wheel, both being connected with a cylinder and piston, an extension of the piston rod of which carries the shifting element of the gear-set. According as the speed of the motor or that of the rear wheels is greater, the gears

are automatically shifted up or down, as the result of the compressed air being admitted to one side of the piston or the other, thus enabling the motor to run at a uniform speed. The action is controlled by a diaphragm, a dash-pot arrangement, H<sup>o</sup> I<sup>s</sup>, being provided to prevent sudden operation.

The operation of the device, as described by the inventor, is, in part, as follows:

Assume that the vehicle is going up a hill driving through the low speed gears C<sup>2</sup>, C<sup>3</sup>. When the level is reached, there being less friction to overcome, the wheels turn faster and throw the intermediate gears C<sup>1</sup>, C<sup>4</sup> into operation. On a further forward movement on the level the speed of the traction wheel is raised by the intermediate gears and the air pump O pumps more air against the diaphragm L<sup>s</sup>, so that the valve L<sup>s</sup> is moved nearly to a closed position to shut off the pressure in the outer end of the large bore H<sup>o</sup> of the cylinder H, so that the preponderance of pressure against the pistons I and I' by way of the branch pipe G<sup>2</sup> causes a movement of the pistons I and I' toward the left, to move the incline J' of the shifter J in engagement with the clutch pin K of the clutch member C<sup>4</sup> of the gear wheel C<sup>4</sup>, to connect the latter with the

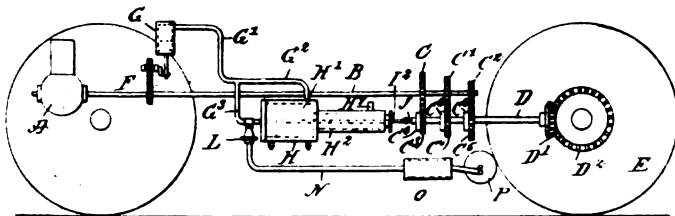

SHOWING METHOD OF INSTALLATION ON A CAR.

shaft D, and consequently the shaft D is rotated at a high rate of speed from the motor shaft B without increasing the speed of the motor A.

When the resistance increases to a certain extent the traction wheels turn slower, the air pressure against the diaphragm L<sup>s</sup> decreases, and the valve L<sup>s</sup> opens to admit sufficient pressure to the outer end of the bore H<sup>o</sup> of the cylinder H to throw the intermediate gears C<sup>1</sup>, C<sup>4</sup> into operation. On a further increase in the friction, as in going up a hill, the traction wheels E, in rotating slower, force the air pump O to pump less air in a given time against the diaphragm L<sup>s</sup>, so that the valve L<sup>s</sup> opens wider, and consequently more air passes from the air pump G through the branch pipe G<sup>2</sup> into the outer end of the large bore H<sup>o</sup>, to cause

the piston I and with it the piston I' to be shifted in the direction of the arrow a', whereby the incline J' of the shifter J moves out of engagement with the clutch pin K of the gear wheel C<sup>4</sup> and moves into engagement with the clutch pin K of the gear wheel C<sup>2</sup> to connect the latter with the shaft D, so that the latter shaft is now rotated from the motor shaft B by way of the gear wheels C<sup>2</sup>, C<sup>3</sup> and the said clutch mechanism. When this takes place, the traction wheels E are driven with more force without change in the normal speed of the motor A.

From the foregoing it will be seen that by the arrangement described the variation of pressure in the outer end of the bore H<sup>o</sup> of the cylinder H, is controlled solely from the traction wheels E, and consequently the motor A, is free to run at a predetermined speed, and the motor A can thus operate to its fullest advantage at all times.

**NOVEL MACHINE FOR TESTING BALL BEARINGS.**

In order to be able to accurately determine the frictional resistance of a bearing as well as its ultimate load-carrying capacity, the Hess-Bright Manufacturing Company, Philadelphia, makers of ball bearings, have devised a most interesting machine. While it is equally adapted to test any form of bearing, whether plain, roller or ball, it has been designed primarily for the latter as a means of maintaining the high standard of the Hess-Bright bearings. This machine will measure the frictional resistance of a ball bearing that is radially loaded up to 15,000 pounds and does this with a factor of error of not more than two per cent. It will also measure the friction incident to a thrust load up to 10,500 pounds and here its accuracy is within .05 per cent. Both these stresses may be applied simultaneously in any desired ratio within the limits given and at speeds ranging from 50 to 2,200 r. p. m.

Hess-Bright ball bearing No. 308 is a size much used in automobile hubs, change speed gears and the like, so that the results of tests it has undergone are of interest. It has a bore of 1.57 inches, a diameter of 3.54 inches and has 8 balls 9-16-inch diameter, kept apart by the elastic separators characteristic of the HB-DWF construction. The radial load was started at 800 pounds and increased to 13,200 pounds by increments of 40 pounds, the test occupying 10 hours running time, the speed corresponding to 24 miles per hour for a 32-inch wheel. The radial load was started at the same point and raised to 11,000 pounds in four and a half hours, at which load it was run for seven and a half hours at 325 r. p. m., or the equivalent of 31 miles an hour in a 32-inch wheel hub. Tests showed the total radial freedom to be .00045 and the total axial freedom .007 inch, both being within the limits of a new bearing and thus showing no appreciable wear. In practice the number 308 bearing is not loaded above 1,000 pounds, so the tests showed it to have more than a tenfold factor of safety.

**AERIAL YACHTS NOW A COMMERCIAL FEATURE.**

PARIS, Feb. 11.—An indication that the airship has already reached an advanced position in the world of commerce and sport is found in some of the catalogues of balloon makers descriptive of 1908 models of aerial yachts for pleasure and touring. Just to take one of these as an example, two 1908 models are described, a large one for military use, fitted with a couple of 70-horsepower engines, and a smaller pleasure yacht, fitted with a 30-horsepower motor and guaranteed to give twenty miles an hour. The standard models are described in detail much as a manufacturer would describe an automobile or a motorboat, but instead of the pleasures of touring on land or water the joy of being able to cruise in the air is set forth in glowing language. The significant thing about it is that firms having won laurels by the construction of successful Government ships should already have adopted fixed types ready to be delivered from stock. The Bayard-Clément firm is said to be receiving orders for dirigibles, and several other large constructors, including Renault, are building aeronautical engines.

## AN EXAMPLE IN PROGRESS THAT TELLS ITS OWN STORY

**A**NYONE who was anxious to invest in a hansom cab—not of the automobile variety, but of the sort to which a four-legged hay motor is usually attached—should have taken up his stand at Broadway and Forty-second street, New York City, just before 2 A. M. Sunday morning, for they were going cheap. "Not a dollar to-night and no chance," said Dan Buckley, as he watched the crowds leaving the Knickerbocker Hotel, hour after hour, without so much as looking at the line of hansoms, now relegated to the background by the new "taxis." Dan is the dean of the nighthawks, those deep-sea cabmen who spurn anything less than a two-dollar bill, no matter how short the ride, and he has cruised throughout the Tenderloin in fair weather and foul for the past twenty-two years. "The days of the nighthawk are over and we might as well give in," he continued. "I'm going to sell my old cab and get out." Thereupon was the hansom buyer's opportunity.

Dan has had six cabs in his long career and they cost as high as \$1,400 apiece, but the impromptu auction held then and there at the curb failed to bring more than \$10 for his last cruiser. "It's all up with us guys. We're all in and down and out. Here goes my old wagon for what you'll pay for it," and with this impromptu speech the bidding was on, the opener being a quarter. The jumps were not much bigger and, there being no offers over \$10, the towering two-wheeler was knocked down to Eddie Poole at that figure. The motive power and its tie ropes were thereupon seized by Charles Crowl as the equivalent of a ten-dollar payment on his stable bill of \$25. Then Bill Lynch, another old-timer, fell in line, followed immediately after-

ward by George Schaefer. Being of more recent vintage, their craft brought \$25 and \$20 respectively, sans power-plant.

In the heyday of his calling, it was nothing unusual for the nighthawk to average \$20 a night, but of late it has been difficult to make that much in a week, and stable charges are higher than ever. The coming of the taxicab has been his undoing, and New York's unsavory institution that has so often been good to the night reporter for a column or more will soon be relegated to the limbo that holds the horse car and the ancient Fifth avenue stage.

No evolution ever proceeded more rapidly and no change was ever made with more silent resignation. The horse driver might have temporarily saved the situation by adopting the taximeter instrument to his vehicle, but his pride would not allow him to climb down from the autocratic position he had held for years, and after a few brief months of struggle with hard times, considerably shortened by reason of a general depression, he has had to get off the box and seek new fields of activity.

In hardly a single instance has the horse driver been able to profit by the good times brought to his trade by the arrival of the taxicab. Under the new system more people travel in cabs than was the case under the old conditions, for, being assured in advance of quick service and honest treatment, there is lesser need to always patronize surface cars and subway. But the young men who knew, or thought they knew, something of automobiles rushed in first and, without any waiting, earned sums that would have satisfied the most rapacious old-time cabby, and made it without robbing the public.

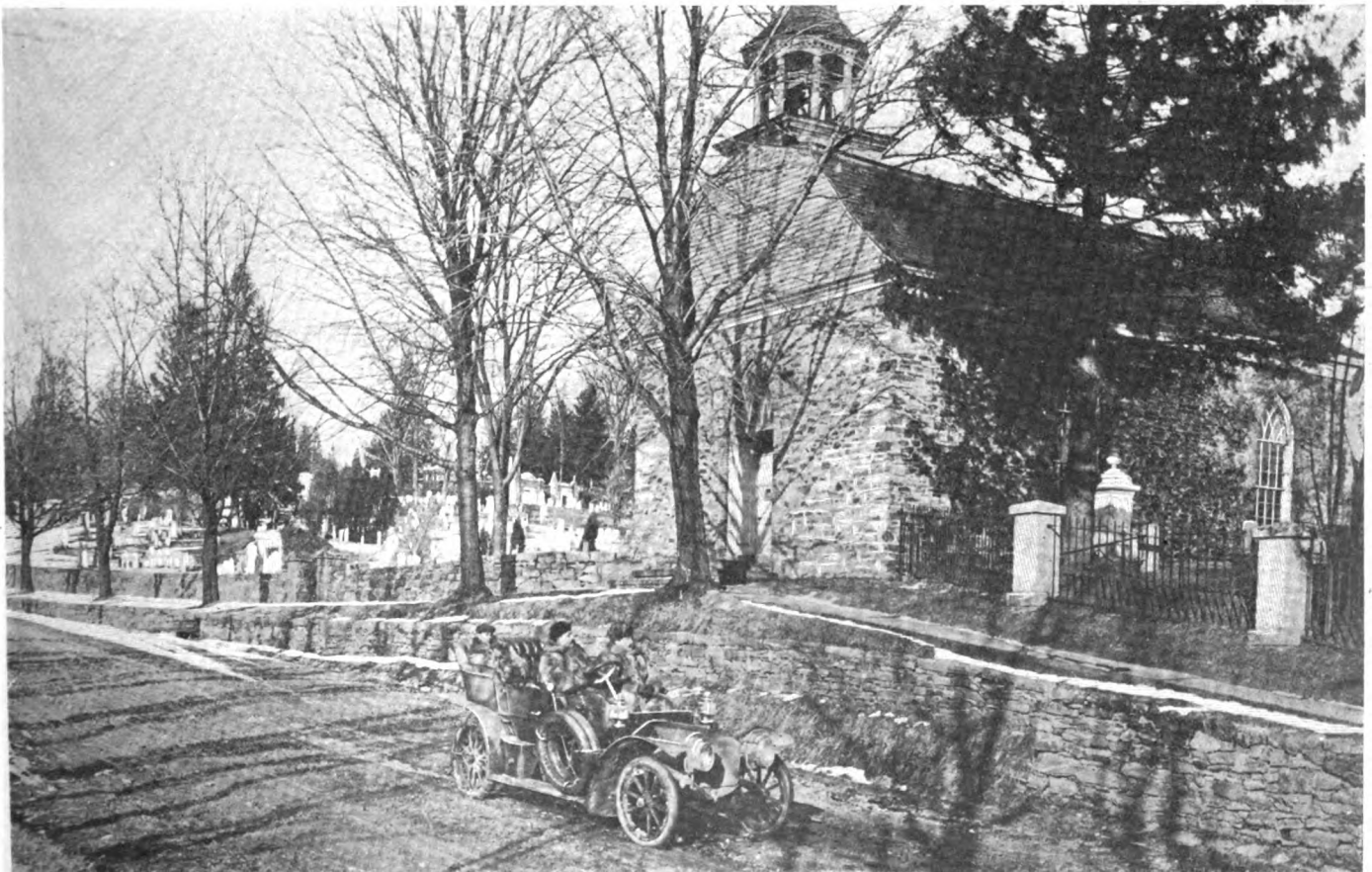

PICTURESQUE SLEEPY HOLLOW CEMETERY WHERE WASHINGTON IRVING IS BURIED. THE CHURCH WAS BUILT IN 1699.

The old graveyard and church figures prominently in Irving's "Legend of Sleepy Hollow." The photograph was taken on the recent run of the Maja car from New York to Poughkeepsie and return in a snowstorm, to see how the vanadium steel springs of the car would withstand the hard roads and rough going. The trip was satisfactory, and Manager E. B. Gallaher also discovered that during the run upwards of 21 miles had been covered for each gallon of fuel used.





GOOD ROADS APOSTLE THATCHER SPEAKING FROM PREMIER.

### A GOOD ROADS ADVOCATE AND HIS MASCOT.

Charles W. Thatcher, in a prairie schooner drawn by two small Spanish mules, has crossed the American continent and is now on his way from the Great Lakes to the Gulf, making speeches as he journeys, endeavoring to arouse national enthusiasm so that Federal assistance will be given for the construction of national highways. While in Louisville, Ky., Mr. Thatcher was the guest of the Louisville Automobile Club, and the photograph shows him addressing a street audience from the rear of a Premier Roadster. He utilizes one of the Spanish mules, "Burro," whom he calls his "Good Roads Mascot," as a pulpit from which to expound his good roads gospel.

### SALES MANAGER KIRKPATRICK ON THE WEST.

CLEVELAND, O., Feb. 17.—W. H. Kirkpatrick, sales manager for the Peerless Motor Car Company, has returned from a trip West. Mr. Kirkpatrick says that the people in the West are making money fast, and they are willing to spend it in the best. He says the six-cylinder car is meeting with a very favorable reception throughout the western country. W. D. Marlow, agent for the Peerless at Colorado Springs, was a visitor at the Peerless factory last week, and turned in orders for five six-cylinder cars for early delivery, in addition to an order for stock cars. H. B. Clarkson, of Kansas City, was another visitor at the Peerless factory. He looked after the Peerless interests at the recent Kansas City show.



ORIENTAL DIPLOMATS ENJOYING A RIDE IN THE WINTON.

Both Gen. Morteza Kahn, Persian Minister to the United States, and Chekib Bey, the Turkish Minister, are enthusiastic autoists. The former is at the wheel of the "Six-Teen-Six" Winton, and the latter occupies the seat beside him. The photograph was taken in the suburbs of Washington.

### ROADS IMPROVING AT TOLEDO FACTORY.

TOLEDO, O., Feb. 17.—"Good roads" is a subject of such absorbing interest in all parts of our country that any information leading to the betterment of our highways is appreciated. Here is a method for road improvement which has been tried out at the Pope-Toledo factory with good results and it is an extremely simple one. On the outside of the factory buildings is a circular speedway, while between the buildings are driveways. These roads are subjected to very severe use from testing cars constantly passing over them, going out and returning to the factory, generally at great speed; heavy traffic of large trucks, heavily loaded touring cars, etc. Naturally these drives and speedways were dust nuisances, to say nothing of the constant repair work to keep the roadbeds in condition. Much experimenting has been done, and the Pope-Toledo people say they have finally hit upon a road treatment which gives excellent results and is very economical. The factory has its own steel treating furnaces, some oil heated. The sediment from the oil used in the heaters, which is crude oil, and with an ordinary sprinkling-can, such as found around any flower garden, is sprinkled over the surface of the roads. Three treatments a season, it is said, makes a roadbed waterproof.



DESIGNER BYRON CARTER IN THE CARTERCAR.

The Cartercar is one of the leading exponents of the friction transmission type of automobiles, and the 1908 model in the photo shows an attractive design.

### AUTOS USED IN MICHIGAN TO "BREAK" TRACKS.

"I have seen automobiles used for many different purposes," said A. L. Kull, vice-president of the Dragon Motor Company, "but, to me, the funniest use I ever saw I ran across in Michigan. There had been a heavy fall of light, dry snow the night before, and it did not pack very well. Our agent took out one of his cars and drove over about five miles of road with two large kettles dragging behind. These kettles were filled with bricks and stones, and as they were drawn along they left two hard-packed tracks, just right for the teams. It seems that these kettle tracks are rather an old device with the farmers and in Winter they use this method of breaking roads through the snow.

"The use of automobiles for breaking snow roads seems to become more general each year. The driver is able to make a straighter track than the old-fashioned team of oxen, which formerly had the field to themselves. In the lumber woods the large contractors use automobiles to visit their different camps, which generally are far back in the woods. I noticed the care which these lumbermen take in building their snow roads, and they are almost perfect for autoing, being hard packed. At night they are sprinkled, and by morning they are smooth, almost level, ice roads.

**THE AUTOMOBILE CALENDAR.**

**AMERICAN.**

**Shows and Meetings.**

- Feb. 21-29.....—Newark, N. J., Electric Park Auditorium, New Jersey Automobile Trade Association and New Jersey Automobile and Motor Club.
- Feb. 24-29.....—Portland, Me., Annual Automobile Show. F. M. Prescott, manager.
- Mar. 7-14.....—Boston, Mechanics' Building and Horticultural Hall, Boston Automobile Dealers' Association. Chester I. Campbell, manager, 5 Park Square.
- Mar. 11.....—Boston, Bay State Auto Association Clubhouse, First Quarterly Meeting, Society of Automobile Engineers.
- Mar. 9-14.....—Buffalo, Convention Hall, Sixth Annual Automobile Show, Automobile Club of Buffalo. Dal H. Lewis, manager.
- Mar. 16-21.....—Indianapolis, Ind., Annual Show, Automobile Dealers' Association.
- Mar. 18-21.....—Rochester, N. Y., New Convention Hall, First Annual Show, Automobile Dealers' Association and Rochester Automobile Club. Bert Van Tuyle, manager.
- Mar. 21-28.....—Toronto, Canada, St. Lawrence Arena, Automobile Show. R. M. Jaffray, manager.
- Apr. 5-12.....—Montreal, Canada, Arena, Third Annual Automobile and Sportsman's Show. R. M. Jaffray, Mgr.
- April 6-8.....—Denver, Mammoth Rink, Annual Automobile Show. G. A. Wahlgreen, manager.

**Race Meets, Hill Climbs, Etc.**

- Feb. 22.....—Boston, 150-mile Endurance Run, Bay State Automobile Association.
- Feb. 25.....—Brooklyn, N. Y., Economy Run Montauk and Return, Long Island Automobile Club.
- Mar. 2-7.....—Ormond-Daytona, Fla., Automobile Club of America.
- Mar. 18-19.....—Savannah, Ga., Savannah Automobile Club.
- Apr. 24.....—Briarcliff Trophy Race, Westchester County, N. Y. Robert L. Morrell, chairman.
- May 4-5.....—Harrisburg-Philadelphia and Return, 150-mile Endurance Run, Motor Club of Harrisburg.
- May 15.....—Chicago, Algonquin Hill Climb, Chicago Motor Club.
- May 30.....—Bridgeport, Conn., Sport Hill Climb, Bridgeport Automobile Club.
- June 24-27.....—Chicago, 1,200-mile Reliability Run, Chicago Motor Club.
- Sept. 14.....—Chicago, Annual Economy Run, Chicago Motor Club.

**FOREIGN.**

**Shows.**

- Mar. 21-28.....—London, Agricultural Hall, Cordingley's Show.
- May 17-June 2.....—Moscow, Russia, International Automobile Exposition, Automobile Club of Moscow.

**Race Meets, Hill Climbs, Etc.**

- April 1-13.....—Monaco Motor Boat Races and Motor Boat Exhibition, International Sporting Club of Monaco.
- April 25-May 25.....—Industrial Vehicle Competition, Automobile Club of France.
- May.....—Paris, Competition for Agricultural Automobiles, auspices of "L'Auto." (Date to be announced.)
- May 10.....—Sicily, Targa Florio, Automobile Club of Italy.
- June 1-18.....—Reliability Trials for Pleasure Cars, Automobile Club of Great Britain.
- June 9-17.....—Touring Competition for the Prince Henry of Prussia Prize, Germany, Imperial Automobile Club of Germany.
- July 6.....—Voiturette Grand Prix, Dieppe Circuit (Automobile Club of France).
- July 7.....—Grand Prix of Automobile Club of France, Dieppe Circuit.
- July 13-17.....—Ostend, Belgium, International Race Week, Automobile Club of Ostend.
- July 20-30.....—Ardennes Circuit Races and Coupe de Liedekerke, Automobile Club of Belgium.
- Aug.....—France, Coupe de la Presse, Automobile Club of France. (Exact date to be announced.)
- Aug. 29-30.....—France, Mont Ventoux Hill Climb, Vauclussen Automobile Club.
- Sept. 1-8.....—French Voiturette Contest, auspices of "L'Auto."
- Oct.....—Berlin, Germany, Gordon-Bennett Balloon Race, Aeronautical Club of Berlin.

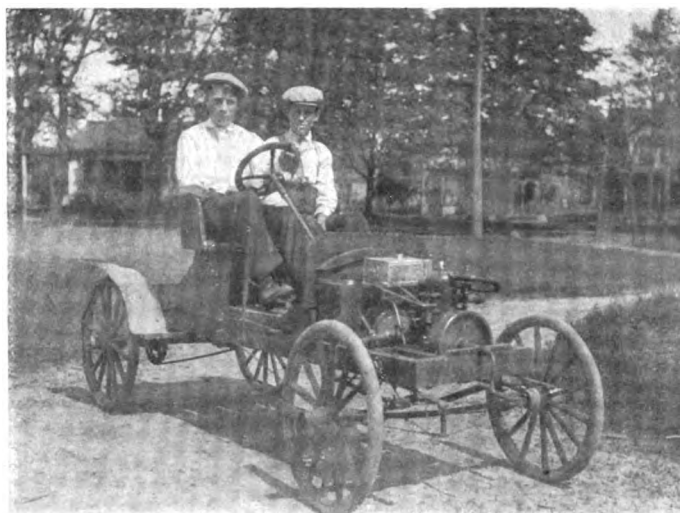

**WILFORD AND WILFRED GODDARD IN THE AUTO THEY BUILT.**

**HOW TWO OHIO BOYS MADE AN AUTO.**

CONNEAUT, O., Feb. 17.—The problem of raising sufficient cash to purchase an automobile, even a one-lunger, second-hand, sold out cheap, looked too long a task for a couple of fifteen-year-old boys. By the time they had scraped up sufficient notes to be able to stroll into the store and look over the machine with the critical eye of a real purchaser, they would probably be too old to be content with such a production. Besides, they could not wait years, anyway.

So Wilford and Winfred Goddard, twin brothers, resolved they would build their own automobile—design it, make the parts, fit them together, paint the machine and drive it without any outside aid. Making an engine was certainly beyond them. But as many a car builder buys his engine, why should not they? By gathering up all spare cash, uniting the sums, cutting off luxuries for a few weeks and generally exercising supervision over their finances, the amount was raised and the order placed for a single-cylinder engine. There was plenty of material around the house, and little by little the automobile grew into form until finally critics ceased to prophesy that it would never go. Four large carriage wheels cut down to a reasonable size and fitted with 28-inch rims and standard bicycle tires with an extra cover, supplied what was wanted in this department. Two lengths of wood and suitable cross sections of the same material supplied the frame.



**WM. L. MULLER, OF DAVENPORT, IA., IN HIS PEERLESS.**

Mr. Muller is one of Iowa's most enthusiastic automobilists and has driven his own car many thousands of miles during the past season.



Vol. XVIII Thursday, February 20, 1908 No. 8

THE CLASS JOURNAL COMPANY

Flatiron Building, Madison Square New York City

H. M. SWETLAND, President

EDITORIAL DEPARTMENT

A. G. BATCHELDER, Managing Editor
R. F. KELSEY Associate Editor C. B. HAYWARD, Engineering Editor
W. F. BRADLEY

BUSINESS DEPARTMENT

A. B. SWETLAND, Business Manager
LOUIS R. SMITH FRANK B. BARNETT
W. I. RALPH, 1035 Old South Building, Boston, Mass.
C. H. GURNETT, H. E. WESTERDALE, 836 Monadnock Block, Chicago, Ill.

Cable Address Autoland, New York
Long Distance Telephone 300 Gramercy, New York

SUBSCRIPTION RATES:

United States and Mexico One Year, \$3.00
Other Countries in Postal Union, including Canada, One Year, 5.00
To Subscribers—Do not send money by ordinary mail. Remit by Draft
Post-Office or Express Money Order, or Register your letter.

FOREIGN SUBSCRIPTION AGENTS:

ENGLAND:—Hiffe & Sons, Limited, 20 Tudor Street, London, E. C.
FRANCE:—Boysseau & Chevillet, 22 Rue de la Banque, Paris.
GERMANY:—A. Seydel Mohrenstrasse 9, Berlin.

Entered at New York, N. Y., as second-class matter.
The Automobile is a consolidation of The Automobile (monthly) and the Motor
Review (weekly), May, 1902, Dealer and Repairman (monthly), October, 1903,
and the Automobile Magazine (monthly), July, 1907.

Table with 2 columns: Copies printed in, and values for 1905 (730,000), 1906 (791,000), and 1907 (888,000).

GRIST OF AUTOMOBILE LEGISLATIVE MILL.

It was to be expected that the appearance on the highways of a new means of transportation would bring with it the necessity of radical revision and readjustment of the existing laws relating thereto.

Throughout the country at the present time, not only in State Legislatures, but also in Congress, there is being heard argument for and against automobile legislation, some of it based on common sense, some of it proposed in a spirit of oppression; some of it meeting with approval and some of it denounced in unmeasured terms.

In one State, Connecticut, we find a common-sense law which seems to answer the needs of the situation; in another State, New Jersey, we find a most obnoxious law and a renewed effort to make it still more drastic.

prosecution, though in bringing them to their just desserts many have been and are being subjected to persecution.

Only through organized efforts—local, State and national—can the flood of legislation be kept in well-defined channels, and in supporting the present administration of the American Automobile Association every automobilist is in reality doing nothing more than insuring conditions satisfactory to himself.

If the Federal Registration bill, introduced in Congress by the American Automobile Association, progresses through the national mill and emerges a law, there should follow the united thanks of automobilists to those men who are now working indefatigably for a consummation desired from one end of the country to the other.



RESUMPTION OF INDUSTRIAL ACTIVITY.

Reports from all parts of the country are to be found every morning in the daily papers telling that mills and foundries are starting up, and these announcements are bringing home to the observant the fact that within a short time the return of confidence and the resumption of industrial activity will be complete.

Primarily this will mean a reduced output during the coming season, considering the number of cars built alone, but it will not be simply from the reason that the manufacturers as a whole have come to the decision to produce a lesser number of cars than their original plans for 1908 called for.

## CONGRESSMAN MOON ON FEDERAL REGISTRATION BILL

PHILADELPHIA, Feb. 15.—At the sixth annual banquet of the Automobile Club of Germantown, held to-night in the well-equipped home of the organization, those present heard most reassuring speeches from a governor, a mayor and a congressman. In the hundred and a half of listeners there were included men prominent in the city's business and political worlds and of unquestioned influence and substantiality.

Mayor Reyburn was the first speaker introduced by President Thomas B. Prosser, and the city's chief magistrate plainly indicated in his remarks that he is a friend of the automobilist.

Governor Edwin S. Stuart particularly dwelt upon the subject of good roads, and in the course of his closely followed speech said:

The matter of good roads is a matter of great importance to me, and I am doing all in my power to improve the condition of the State highways. The Legislature in its last session appropriated all the money that it could spare from the Treasury, but to get roads as good as those of Europe takes time and patience. If you motorists will only give us time we will have in this State the finest highways in the country, but in obtaining this it must be impressed upon township road supervisors that they must keep them in repair after the State builds them. We need the help of automobilists in securing this aid.

But it was the speech of Congressman Reuben O. Moon, a member of the Judiciary Committee of the House of Representatives, that met with the greatest acclaim. The Federal Registration bill, prepared and introduced by the Legislative Board of the American Automobile Association, is now before this committee and a public hearing has been scheduled for March 12. Congressman Moon, in the course of his forcibly delivered speech, said:

I do not believe that there is to-day in Washington a member of Congress of either house who does not know that an automobile bill is pending. I do not believe there is a member who has not received letters from his automobilizing constituents upon this mat-

ter, and they all come to me as a result, because I am a member of the committee which must pass upon it before it can be presented before Congress.

I can assure you and all automobilists that you are going to receive fair, earnest and sincere consideration in Washington. There is no spirit in the National Capitol among the legislative bodies which is inimical to what you desire. Everyone realizes that there are at present serious obstacles to the progress of the sport and business of automobilizing which need Federal attention. The whole matter depends upon the constitutional power of Congress, and though speaking unofficially, I believe that we have the invested power to grant what you desire, and you are entitled to our earnest consideration.

Freedom of intercourse between the various parts of the country is important, and anything that will break down sectional pride, prejudice and jealousy, is something which goes to make up and strengthen the nation. You are utilizing a novel and effective method of doing this, and broadening interstate relations. It is a fact that commerce is not the only bond of unity between the States, but there must be an intermingling between the people, and this is a great link in the strength of the national chain. There is nothing in the country to-day that is doing more to strengthen the weak links than the automobile. It will give us great pleasure to help you in securing this national legislation, and when I can serve you in any way you have only to call upon Mr. Moon in Washington.

It was to be expected that these words from a congressman would be received with great satisfaction and applause.

Charles W. Bosworth, of Springfield, Mass., next supplied an excellent "fireworks" speech of the evening, and following him came O. S. Henniger, of Allentown, who made the humorous address of the night.

At the head table also sat District Attorney S. P. Rotan, E. T. Stotesbury, Vice-President C. M. Thompson, and Robert P. Hooper, chairman of the A. A. A. Good Roads Board. The guests included Frederick H. Elliott, secretary of the A. A. A.; Charles J. Swain, ex-president of the Quaker City Motor Club, and A. G. Batchelder, managing editor of THE AUTOMOBILE. The function was the most successful in the history of the organization.

### FEDERAL AID IN ROADS BUILDING.

WASHINGTON, D. C., Feb. 17.—Out of the mass of good roads bills that have been introduced in Congress since the opening of the present session, it is likely that a bill will be evolved that can be enacted into law. There is no gainsaying the fact that the good roads movement has many friends in Congress, and they believe the time is ripe for the Federal Government to step in and do something for the good of the country's highways.

Not to be outdone by Representative Currier, who wants Congress to establish a National Highways Commission, Representative Sulzer, who represents a New York City district in Congress, has framed a bill to promote the construction of good roads and the efficiency of the postal service. In brief, the bill provides that upon the application of the proper authorities representing any State, the Secretary of the Treasury shall loan to such State for the construction or improvement of post roads within such State the actual cost of such construction or improvement. The Post Office Department is to have general supervision over the construction or improvement of said post roads.

The provision is made that one twenty-fifth part of all money received from the United States Government under this arrangement must be returned to the United States Treasury each year by the State receiving the same until the whole amount received by such State shall have been returned. No interest is to be charged upon money loaned in this manner, provided it is promptly repaid, as stipulated, but a 5 per centum interest charge will be added to all deferred payments.

### FRANCE AND THE ROADS PROBLEM.

PARIS, Feb. 10.—Frankly recognizing that even the best of existing highways are not what they should be for present methods of transportation, and are likely to become still less suited with the growth of the automobile, Minister of Public Works Barthou has called an international conference, to be held probably in Paris preceding the annual automobile Salon. The general study will be on the adaptation of highways to new methods of travel, the principal divisions of the congress being:

1. Road construction and repair: road foundations, methods of work, results obtained.
2. General methods of road preservation: stone roads, paved roads, and various.
3. Anti-dust methods: the use of tar and other products, sweeping and watering, technical and economic results.
4. Future roads: laying out in length and cross section, surface, various difficulties, curves, special tracks, etc.
5. Traffic: effect of new methods of locomotion on present roads, damage due to speed and weight, influence of tires, steel rims, exhaust, etc.; effect of roads on vehicles, deterioration of mechanical organs, skidding, etc.
6. Road signals: kilometric signposts, direction, distance and altitude indicators, danger signals.
7. The road and industrial transportation by trolley cars, buses and automobiles.

Invitations to the conference will be sent out to all automobile associations and to every organized body in any way connected with the improvement of highways, while the government of every foreign country will be asked by the French Ministry to send an official delegate. The question of perfect highway throughout Europe has become such an important one that much good is anticipated from the gathering.



## M. J. BUDLONG LEAVES A. L. A. M. TO JOIN PACKARD.

**A**FTER a few months at the head of the Association of Licensed Automobile Manufacturers, Milton J. Budlong will shortly join the staff of the Packard Motor Car Company in the capacity of assistant general manager.

Interviewed at the offices of the A. L. A. M., Mr. Budlong declared that there was now no reason to hide the fact that his connection with the Licensed Association had never been considered as other than a temporary one. "When I took up the direction of the association affairs last November I was already in negotiation with the Packard company, and my departure from the association affairs is, therefore, no sudden move.

"For the last four months the work of reorganization of the A. L. A. M. has been carried on so thoroughly that the association is now in a stronger and more satisfactory condition than at any previous period. While there has been a reduction of expenses, there has been no curtailment of the activities of the association; better results are being obtained by more harmonious working, litigation in connection with the Selden patent is progressing satisfactorily, and the whole situation is one of greater strength.

"The agency position is one point on which erroneous impressions have got abroad. Instead of abandonment, this branch of the association work will be carried on with more thoroughness than ever, the exclusive agency policy being enforced as it has not been done in the past. The technical work, too, will be vigorously pursued, the closing of the

laboratory at Hartford being but temporary. Litigation in connection with the Selden patent is in such an advanced condition that the final tests of the Selden models will positively be held Monday and Tuesday of next week."

No definite action appears to have yet been taken towards the appointment of a successor to Mr. Budlong, nor is the date of his departure altogether decided upon. "There yet remains a number of matters to be put into shape," said Mr. Budlong, "and I shall not leave the association offices until everything is on a sound footing."

From the Packard company this announcement comes: "An addition to the administrative staff of the Packard Motor Car Company brings to it, as assistant general manager, Milton J. Budlong, manager of the Association of Licensed Automobile Manufacturers. He leaves the association to join the Packard forces shortly to assist Henry B. Joy and S. D. Waldon in executive affairs. Mr. Budlong is a valuable accession to the Packard company. His well known ability as a factory executive is supplemented by a long and profitable experience. Prior to becoming manager of the A. L. A. M. last November, Mr. Budlong was for several years president of the Electric Vehicle Company. At one time he was president of the National Association of Automobile Manufacturers, while before his connection with the Electric Vehicle Company he had obtained a thorough business training by many years in both the retail and manufacturing ends of the bicycle trade."

### NEWARK'S BIG SHOW OPENS FRIDAY.

NEWARK, N. J., Feb. 18.—The work of transforming the big auditorium at Electric Park into a palace of gold and white is now well under way and the exhibits will begin to arrive to-morrow, preparatory to the opening of Newark's first automobile show on Friday, February 21. The show will remain open until the following Saturday week, February 29. The following concerns have taken space: Greene Motor Car Company, Locomobile and Oldsmobile; Motor Car Company of New Jersey, Packard, Autocar, Cadillac and Northern; Herman J. Koehler, Buick and Waltham; Jacob W. Mason, Maxwell and Stoddard-Dayton; Star Motor Car Company, Pullman and Napier; W. S. Maltby, Corbin; Highgrade Motor Car Company, Ford; Clavert-Zusi Company, Winton; Charles Cooper, Atlas; Osborne & Morton, Brick Church Automobile Company, Auburn; Carl H. Page Company, Peerless; Ellis Motor Car Company, Knox and Pierce Great Arrow; Rickey Machine Company, Marmon; Sheldon W. Chase, Holsman; Mitchell Auto Company of New Jersey, Plainfield Motor Company and Central Motor Company of Bloomfield, Mitchell cars; Brush-McLaren Motor Company, Brush runabout; J. J. Meyer.

### YALESIANS CAN'T HAVE HILL CLIMB.

NEW HAVEN, CONN., Feb. 17.—At a weekly meeting of the New Haven Auto Dealers' Association, it was announced that the local show will be held in Music Hall, March 18 to 24. Special nights have been designated.

At a meeting of the City Park Board held Saturday a petition was received from the Yale Auto Club asking that permission be granted them to hold a hill climbing contest in East or West Rock parks during the coming spring. Both of these parks are the finest mountain parks in this part of the country, but automobiles are prohibited by city ordinances. In view of this fact, the board decided that it had no authority to grant this request.

### DETROIT SUPPORTED TWO SHOWS.

DETROIT, MICH., Feb. 17.—All doubt as to the ability of Detroit to support two automobile shows appears to have been set at rest by last week's achievement, when the Tri-State Automobile and Sportsmen's Association held its seventh annual show. It was freely predicted that the dealers' show held earlier in the winter at Riverview Park would kill the second one, but these fears proved unfounded. Not only was the attendance up to former marks, but sales were of a gratifying nature. Some ninety cars were sold at the armory, the total amount involved in the transactions being close to \$125,000. Besides this a considerable amount of wholesale business was transacted.

Whether there will be two shows another year is yet to be determined. The Tri-State Association has engaged the armory for 1909, and the attitude of the Dealers' Association is being awaited with interest. Manager E. E. McMaster, to whose good work can be attributed the success achieved by the Tri-State Association, was presented with a handsome diamond ring just before the close of the show, the gift being from exhibitors as a token of their appreciation for what he had done.

### BISON CITY SHOW WILL BE A FINE ONE.

BUFFALO, N. Y., Feb. 17.—Arrangements for the automobile show to be held in Convention Hall during the week of March 9 are well under way. Secretary D. H. Lewis declares the approaching display will be the finest that the Buffalo Automobile Club and Dealers' Association have ever attempted. The feature, aside from the many exhibits, will be the ceiling and mural decorations. These will be done in blue and gold, and the effect will be, when the myriad electric lights are turned on, of a canopied heaven containing thousands of stars. There will be four large groups of electric lights, each composed of 500 bulbs, and also fourteen festoons of electric illuminations hanging from the ceiling.



ONE OF THE BEST STRETCHES ON LA ROCHE AVENUE.

### SAVANNAH'S BIG ROAD MEET.

SAVANNAH, GA., Feb. 17.—With the stock chassis speed endurance contests a little less than a month away, Savannahians are wrought up over the idea of the big road races, and from the inquiries which are pouring in the success of the meet will far exceed the most sanguine expectations of the Savannah Automobile Club when it undertook to promote the races. Everything is being rapidly whipped into shape for the contests, and the local club is on the last lap of the preparations for the three events. At a recent meeting of the executive board having the races in charge at this end, on which are the mayor and the most prominent citizens, a syndicate of ten of the monied men of the city was formed to underwrite the affair, thus removing any financial obstacle which might have been encountered. Immediately following this action, Mayor Tiedeman wired twenty-nine manufacturers, whose entries have not yet been received, a guarantee that the races would be held on the dates announced.

With the obstacles which appear to be thrown in the way of the proposed Long Island course for the Vanderbilt Cup race, the Savannah Automobile Club is already getting ready to make a bid for this blue ribbon event of American automobile racing. It is believed here that the local course is far and away the best one available for the contest for the Vanderbilt Cup, and that Savannah will, by its conduct of the stock car races, establish her claim to the bigger event. Added to the magnificent course which is offered, it is believed that the facilities for policing it are the best which can be obtained in America.

In Savannah, a city of 75,000 inhabitants, there is a citizen soldiery, composing the National Guard, of over 1,500 men. These are the flower of the city's population. At recent meetings of the commands which make up this force, resolutions were adopted without a dissenting vote offering to police the course for the stock car races. Following this

up, the Hon. Hoke Smith, Governor of the State, gave his promise to the people here that he would order out the militia to police the course. This is but a detail which shows the interest being manifested in the races. The County Commissioners have tendered the services of the convicts to assist in preparing the roads for the races.

A slight change has been made in the course, which eliminates four turns and substitutes two others. This change leaves the course practically the same length as before, and in addition gives a straightaway run to the grandstands of a little over three miles of the widest and best roads in the course. In order to make this change a stretch of road a quarter of a mile has to be paved, but this work is already under way. Practically few roads intersect the course. As it stands a corner of the course is bisected by one of the big railway systems entering the city, but this is to be avoided by a wide sweeping curve which will leave the railroad tracks outside. Where the suburban street railway lines bisect the course they are to be paved over, and high foot bridges erected over the tracks, so that passengers may be transferred from one side of the road to the other without interfering with the progress of the races.

#### Day of Big Race to Be Civic Holiday.

Mayor Tiedeman has announced that he will declare a public holiday for March 19, when the 360-mile race will be held for the Savannah Trophy. The Clearing House Association will probably declare Saturday banking hours for both days of the races. The railroads have promised cheap rates from all points within a wide radius, and tourist rates will prevail from the more distant points. An issue of 25,000 sets of postcards showing twelve views of different parts of the course is being sent out. A quarter of a million booklets have been printed by the Chamber of Commerce advertising the races, and these are being stuffed into the mail sent out by the business houses of the city.

The interest in Savannah is being matched by a goodly measure of interest from the outside. A number of men representing the manufacturers have visited Savannah and hardly a day passes but some new ones show up. These are obtaining a look over the course for the purpose of reporting to the manufacturers. Frank Leland, who will share with Barney Oldfield the honor of piloting the Stearns entries, has been on the ground and drove a Stearns car over the course. He remained in the city several days, departing with the remark on the course that it was "simply wonderful." R. B. North, representing the Locomobile people, is now in the city. W. S. Morton Mead, of the Lozier Company, has just left. He says: "The people in the North don't know such a course exists in America."

Walter West, of the Empire Tire Company, was among the several representatives of tire companies to go over the course within the last few days. He says: "There is no course in the United States so adapted to speed as the Savannah course." R. H. Johnston, of the White Company, says: "It will be a record-breaking event." J. M. Rich, of Minneapolis, a tourist who is wintering at Savannah with his Stoddard-Dayton roadster, says of the roads: "There are no such roads in the United States as those around Savannah, and I have traveled all over the country."

In fact, the Savannah people are beginning to fear that the roads are too good for the Vanderbilt Cup race. One member of the Technical Board of the A. A. A., when taken over the course previous to the granting of the sanction for the March meeting, inquired, "Where are your hills?" He thought there ought to be hills to give their climbing as a feature of the tests the race would impose on the machines. The country is as flat as a billiard table, but if the hills are insisted on the Savannahians would be tempted to build some artificial ones just to be accommodating. As a speed-eater



H. S. RICH TRYING SAVANNAH COURSE IN HIS STODDARD-DAYTON.

the course can't be beat. Local drivers have negotiated some of the straight stretches at 79 miles an hour. Mr. North, in his Locomobile, jumped his speedmeter to its limit, seventy miles, within a short time after his getaway on the first stretch that goes straight as a crow flies to its first turn five miles away.

The contract for the first grandstand, to seat 5,000, has been let, and the city has granted space for the parking of automobiles and carriages. The decision as to the trophies, which will cost \$3,000, and for which designs have been submitted by Tiffany, Gorham and other nationally known silversmiths, will be made within a few days.

In many Northern cities special cars are being arranged for to bring parties to Savannah. Sidney B. Bowman, the New York agent for the Apperson, writes that his party will have a special car from New York city on March 16. President Chalmers and Vice-President Coffin, of the Thomas Detroit Motor Company, are among other tradesmen coming.

Event No. 3, it has been officially announced, is not to be limited to six-cylinder cars, but will be open to all cars of 575 or more cubic inches cylinder displacement, providing they otherwise conform to stock limitations.

#### Wants Endurance Run, Philadelphia to Savannah.

PHILADELPHIA, Feb. 17.—Ever since the New Year's run of the Quaker City Motor Club, A. J. King, manager of the local Studebaker agency, has been carrying a good-sized chip on his shoulder. His car was one of the three clean-scorers that was allowed to start in the run-over. It will be recalled that the White was declared the ultimate winner after one of the hardest and closest contests on record. Now Manager King sees a chance to get even. The rush for the Savannah races next month will attract quite a number of local enthusiasts, and he proposes a race from Philadelphia to Savannah, with the White, Peerless and Studebaker as contestants.

#### MAXWELL CHALLENGE ACCEPTED BY STANLEY.

The Maxwell twelve-cylinder racer and F. E. Stanley's short-distance steam sprinter will struggle for speed supremacy on some date yet to be settled between May 13 and 17. When the Dewar trophy was removed from the program of the Ormond meet, the Maxwell-Briscoe Company issued a challenge to the Stanley for a special match on the Florida beach. It is not possible to take the steamer to Ormond, but Mr. Stanley is willing to meet his multiple-cylinder adversary at a later date and has agreed to the period selected. During the races at Ormond F. E. Stanley and B. J. Briscoe, Jr., will confer on details. Atlantic City, Cape May, or some other straightaway will be chosen and other cars may enter.

#### FLORIDA'S MEET TO TAKE PLACE.

All doubt about the holding of the Ormond-Daytona Beach races in Florida during the week of March 2-7 was set at rest Monday, when, after a meeting of the Contest Committee of the Automobile Club of America, Chairman Robert Lee Morrell made the definite statement that the races would be held as advertised. He said:

"We have received no less than twenty-eight entries for the six events, which include twelve of the highest powered cars in the world, and if records do not fall next month I will be surprised. So many rumors have been in circulation in regard to these races that many dealers and manufacturers have refrained from entering their cars, and in order to give them an opportunity to come in we have extended the time for receiving entries up to February 29. Mr. Butler and myself will leave New York on Saturday for Florida to arrange the final details for the races. We have also secured a special compartment club car for the accommodation of the members and contestants, which will leave New York Saturday, February 29, over the Seaboard line."

#### MISSOURI WANTS VANDERBILT CUP RACE.

JEFFERSON CITY, Mo., Feb. 17.—The St. Louis Automobile Club wants the Vanderbilt Cup race for 1908 held in Missouri. The club has been after Governor Folk regarding the use of troops in guarding a course. To-day Governor Folk stated that he would permit the use of the National Guard to police a circuit for the Vanderbilt Cup race if it is held in Missouri. Two courses are being considered, both being within twenty-five miles of the city. It is said that either one of the proposed courses will meet all the requirements of the most exacting racing board.



CONVICTS ARE AT WORK ON THE FAST SAVANNAH COURSE.

## IN THE PARLIAMENTS OF THE AUTO CLUBS

### BUFFALO WANTS THE NATIONAL CONVENTION.

BUFFALO, N. Y., Feb. 17.—The Automobile Club of Buffalo held its first of a series of winter entertainments in the Main street clubrooms last Saturday night. President Hower reported that the organization was rapidly closing on the Automobile Club of America in the race for the largest membership of any automobile club in the country. The Buffalo club now has a membership of 1,099 to its rival's 1,500. He reported progress in the matter of the Niagara boulevard.

President William H. Hotchkiss of the American Automobile Association called upon the members to secure for Buffalo this summer the National Automobile Convention. He said the Association would hold its first great convention this year, and said the gathering would bring together all

### HARRISBURG'S CLUB ELECTS NEW OFFICERS.

HARRISBURG, PA., Feb. 17.—At the annual meeting of the Motor Club of Harrisburg, held at its headquarters in the Patriot Building, the following officers were unanimously elected: Vance C. McCormick, president; O. C. Robertson, first vice-president; C. C. Cumbler, second vice-president; J. Clyde Myton, third vice-president; J. Sydney Sible, secretary, and J. C. Nissley, treasurer. J. C. Aldrich was elected to the board of governors for a two-year term, and Howard L. Jenkins, James McCormick, Jr., and Roy Senseman for three-year terms. The election was followed by a smoker, at which the plans for the big endurance run next May were discussed at length. At the business meeting which preceded the election, the good roads committee read a report of its work

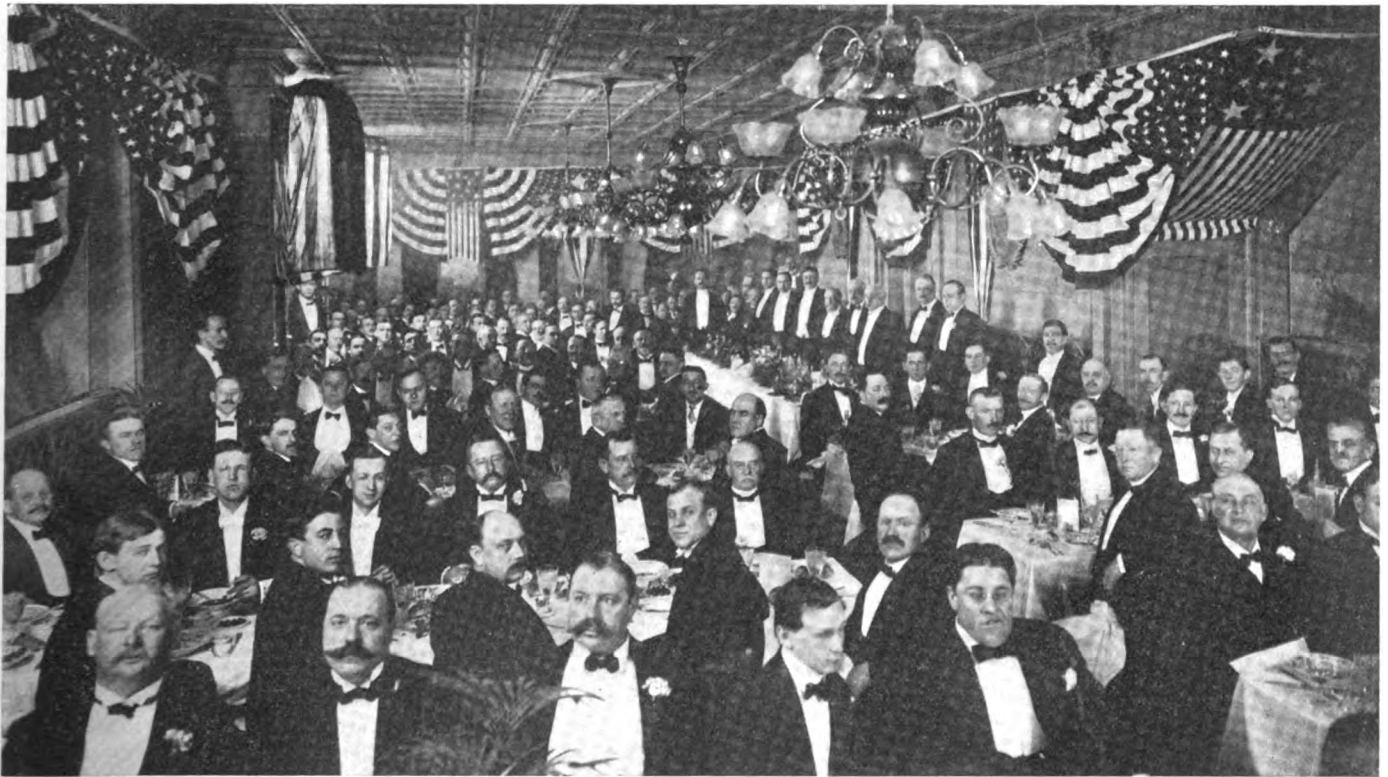

BANQUET NEW JERSEY AUTOMOBILE CLUB, HELD, NEWARK, N. J., FEBRUARY 6, AT WHICH THE JERSEY LAW WAS DISCUSSED.

good roads experts, highway commissioners, automobile legislators and motor enthusiasts. It would be a general congress for all interested in automobiling, at which the solution of many difficult questions would undoubtedly take place. There would also be speed and technical tests. President Hotchkiss said Buffalo would again be the starting point of the tour.

President Hower announced that the directors had subscribed \$500 to land the convention, and E. R. Thomas, of the E. R. Thomas Motor Company, had personally contributed \$250. He said he had an assurance that G. N. Pierce, of the George N. Pierce Company, would contribute an equal amount. Buffalo's claims on the convention are strong and consistent, as the city is a central shipping point which would make it easy to land cars there without undue expense, while it also has another strong factor in its favor in its close proximity to Niagara Falls, which is an attraction of never-failing interest that will probably help tip the balance of favor in the direction of the city by the lake. Various forms of vaudeville entertainment were arranged by Howard D. Herr, the chairman of the entertainment committee.

during the past year and talks on good roads were given by J. C. Nissley, J. S. Sible and O. C. Robertson. R. C. Halde-man, chairman of the contest committee, reported on the work accomplished by his committee during the year, as well as the plans for this year's work, while Charles A. Sef-ton, head of the membership committee, reported good progress. Secretary Sible broached the matter of affiliation with the Pennsylvania Motor Federation, and it was resolved to apply for membership. W. O. Hickok, 3d, brought to the attention of the club members the Federal Registration bill now pending, and it was resolved that a committee of three be appointed to call on Congressman Olmstead to ask his support.

### HARTFORD'S ENDURANCE RUN SET FOR MAY 16.

HARTFORD, CONN., Feb. 17.—Saturday, May 16, is the day that has been selected for the 200-mile endurance run of the Automobile Club of Hartford, and the following route has been decided upon: Hartford to Middletown, to Meriden, to Southington, to Waterbury, to Thomaston, to Bristol, to New



Britain, to Hartford. The distance is approximately 100 miles, and the course must be covered twice. The event will be under the direction of the committee on racing, which consists of Hiram P. Maxim, chairman; C. H. Gillette, C. D. Rice, F. W. Dart and W. T. Plimpton. At the last meeting of the club 27 new members were admitted.

#### CANADA'S MOTOR LEAGUE ACTIVE.

TORONTO, ONT., Feb. 14.—An enthusiastic annual meeting of the Ontario Motor League was held the other evening at the King Edward Hotel. Noel Marshall, the retiring president, occupied the chair. The election of officers for the ensuing year resulted as follows: President, T. A. Russell; vice-president, Wm. Dobie; directors, George H. Gooderham, A. E. Chatterton, F. E. Mutton, W. Stone, J. C. Eaton, F. F. Miller, W. W. Doran, George Graham, Lloyd Harris, Paul J. Myler, O. Hezlewood and Noel Marshall.

It will be remembered that the Ontario Motor League a year ago succeeded the Toronto Automobile Club, and is now a provincial organization. The membership has extended largely to members outside of Toronto, and it is the purpose of the league to encourage the organization of local clubs in outside towns, which will be in affiliation with it, and thus strengthen the influence of the Ontario Motor League in promoting the common interests of motorists in Ontario.

#### HERE'S AN IDEA TO INCREASE MEMBERSHIP.

WASHINGTON, D. C., Feb. 17.—A novel plan has been devised by the Automobile Club of Washington to increase its membership. The entire membership has been divided into two parts, one part of which will be captained by F. S. Bliven and the other by A. G. Newmeyer, and the two opposing sides will endeavor to bring in the largest number of new members. The losing side will stand the expense of a smoker at the club's country home. Mr. Bliven will have as his lieutenant Rudolph Jose, while Harry Ward will act as his secretary. Mr. Newmeyer has designated H. Chadwick Hunter and Royce Hough to act in the same capacity for him. Each side is out to win and the rivalry is intense.

#### CLEVELAND'S CLUB IS A LIVE A. A. A. BODY.

CLEVELAND, O., Feb. 17.—In the bulletin of the Cleveland Automobile Club, just issued, are the following paragraphs:

"Have you ever stopped to think that you are delaying the advent of ideal motoring conditions whenever you thoughtlessly neglect your customary courtesy to the driver of the horse-drawn vehicle?"

"The quickest way to 'educate' the farmer is to sell him an automobile—within ten days after he'll be clamoring for a Uniform Motor Vehicle Bill and the passage of the Good Roads Bill."

"A careful and courteous driver presents irrefutable argument for more liberal laws."

"Isn't it worth \$10 a year to you to feel that you are a member of the Cleveland Automobile Club, the American Automobile Association and the Ohio State Automobile Association, and are doing your part to help motoring conditions throughout the city, State and nation?"

#### MANITOBIANS ORGANIZE FOR PROTECTION.

WINNIPEG, Man., Feb. 15.—The efforts of Manitoba farmers to rush a bill through the legislature governing automobiles has led to the formation of the Manitoba Motor League. At a special meeting held at the Winnipeg Grain Exchange the following officers were elected for the season of 1908: Honorary President, Judge Phippen, Winnipeg Automobile Club; president, W. A. Elliott, Brandon Automobile Club; first vice-president, D. Boyce Sprague, Winnipeg Automobile Club; second vice-president, Joseph Maw, Winnipeg Automobile Club; third vice-president, Harry Stevens, Portage La Prairie Automobile Club; secretary, W. R. Bacolf, Winnipeg Automobile Club; treasurer, L. R. Barrett, Winnipeg Automobile Club.

## DOINGS OF THE SKY NAVIGATORS.

### ELEVEN BIDS FOR ARMY DIRIGIBLE.

Eleven persons or firms are willing to build a dirigible balloon for the United States Army at prices varying from \$6,000 to \$33,500. The bids, which are being considered at the office of Brigadier Gen. James Allen, Chief Signal Officer, closely follow the prescribed specifications and are believed to be of a sufficiently satisfactory nature to allow of an award being made. Should more than one balloon be considered suitable, an effort will be made to obtain sufficient funds to allow of the purchase of two dirigibles. The following is the complete list of bidders, with the price quoted by each:

Harry B. Schiller, 514 Brown street, Philadelphia; time, 180 days .....	\$33,500
S. C. Rockman, 2844 Lehigh street, Philadelphia; 180 days....	25,000
Peter Cooper Hewitt, Madison Square Tower, New York City; 200 days .....	20,000
Lewis Lupetli, Paris, France; 90 days.....	20,000
Capt. Raymond Anglemire, Chicago; 90 days.....	17,500
Carle E. Myers, Frankfort, N. Y.; 120 days.....	11,994
Bumbaugh and Helmann, St. Louis; 250 days.....	10,000
Charles Ellis, Toledo, Ohio; no time given.....	10,000
William Reifersheld, Streator, Ill.; 150 days.....	8,000
Thomas S. Baldwin, 78 Madison Square, New York City; 150 days .....	6,750
G. F. Myer, Hammondsport, N. Y.; 100 days.....	6,000

### AERO CLUBS TO FORM NATIONAL FEDERATION.

Arrangements have been completed by the Aero Club of America for the formation of a national federation of the aeronautical clubs of the United States, of which there are now about one dozen. Boston, St. Louis, Philadelphia and Canton, O., four of the most influential clubs in the country, have given their support to a scheme which will doubtless in a short time combine all similar associations in the United States. The plan of federation will closely follow that adopted with considerable success in France, the federated clubs having equal representation in all matters of national interest, and the Aero Club of America representing this country in all foreign relationships.

### ZEPPELIN TO BUILD A 100-PASSENGER AIRSHIP.

BERLIN, Feb. 11.—Count Zeppelin, as soon as he has completed the balloon now under construction, intends designing a dirigible airship commodious enough to convey 100 persons, a matter not at all as improbable as the majority of people would think, for past experiments all point that such a balloon could be constructed on the same principles as the present ones are, with the increased diameter and length and greatly increasing the carrying capacity. Major Hoernes, the noted Viennese expert, is of the same opinion as the Count, and both men substantiate their statements by figures.

### 23 ENTRIES FOR BENNETT BALLOON RACE.

BERLIN, Feb. 11.—Twenty-three entries have already been received for the aeronautical race for the James Gordon Bennett trophy to be started from the suburbs of Berlin next October. Last year the race at St. Louis only attracted nine entries, and the first event at Paris secured sixteen starters. The countries engaged in the contest are the United States, Germany, Belgium, England, France, Italy and Spain, each with three balloons, and Switzerland with two. Russian and Austrian aeronauts have also promised to compete.

### AERO CLUB ANNUAL DINNER MARCH 14.

The second annual dinner of the Aero Club of America has been fixed for March 14, at the St. Regis Hotel. The plan of seating, which was tried so successfully last year, will be repeated, members being seated in the order in which application for invitations is received.

**JONES MAKES FIRST AMERICAN TAXIMETER.**

Anticipating an early demand in this country for a reliable taximeter, Joseph W. Jones, of New York, the pioneer inventor of the speedometer, made a close study of the European models three years ago when they were already in universal use on the horse cabs of Paris and Berlin. These early types of cab fare registers had numerous defects and, with the latter in mind, Mr. Jones set about designing an instrument of his own, which is now about to be placed on the market, and is known as the Jones Taximeter. The instrument measures about seven inches in diameter by four inches through, and has a silver dial-face carrying figures indicating the tariffs and extras, as well as the total fare to be paid. The dial on the reverse gives the total of all moneys collected, total mileage and trip mileage, which can be reset by the driver. It also shows a separate count of the number of trips with single and double tariff. A vacant sign is also displayed on the rear and, when turned to a horizontal position, sets the instrument at Tariff 1 and registers the initial charge of 30 cents. For each additional quarter mile a charge of 10 cents is registered and added to the total, the driver turning a knob on the back for any extras, which are automatically totaled. For four or more passengers the driver turns the vacant sign to the left, causing the instrument to register an additional 10-cent charge for every sixth of a mile. A clock mechanism registers equivalent charges for waiting time.



FRONT AND REAR VIEWS OF THE JONES TAXIMETER.

**AUTO CREDIT ASSOCIATION DOES GOOD WORK.**

At its annual meeting held last month, the Automobile Trade Credit Association elected George L. Holmes, of the Jones Speedometer Company, and Fred S. Wilson, assistant secretary of the Trenton Rubber Manufacturing Company, members of the board of directors. The other members of the board are W. B. Lasher, Weed Chain Tire Grip Company; Carl Kaufman, Motor Car Equipment Company; H. B. Mirick, National Electric Supply Company; E. S. Fretz, Light Manufacturing & Foundry Company. The association, which has an office at 80 Wall street, New York City, is a purely co-operative organization, which is officered and managed by its members for their mutual benefit in the extension of credit and the collection of outstanding accounts. It is the only credit organization of its kind in the industry and is confined to manufacturers and wholesalers in the automobile and motor boat field. The officers are W. B. Lasher, Weed Tire Chain Grip Company, president; M. J. Martin, G. A. Haws Company, treasurer, and Franz Neilson, secretary. Its success is evident from the fact that claims aggregating \$75,000 were turned over to it for collection during 1907, of which in excess of 75 per cent. was collected at no expense to the members other than the annual dues, which are small.

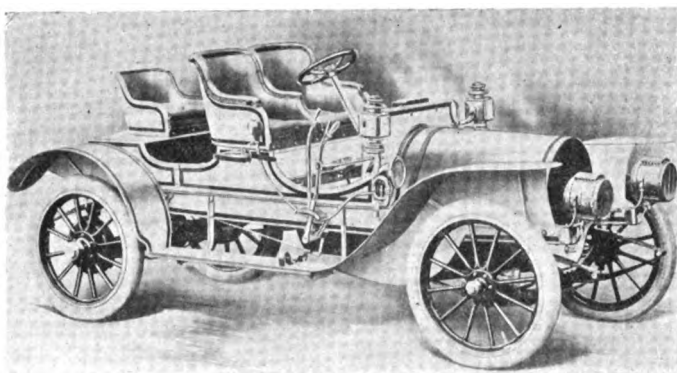

WELL DEFINED LINES OF THE NEW FRANKLIN ROADSTER.

**TWO ATTRACTIVE FRANKLIN MODELS.**

Now that chassis design and construction are approaching more and more to a uniform standard in many respects, not alone where the various models of the individual manufacturer are concerned, but considering American cars as a whole, regardless of the special exclusive features to be found on many of them, an increased amount of attention is being paid to the matter of body design. The latter reached the status of an art with the carriage builder many years ago, but it is only recently that the automobile manufacturer began to give it the amount of attention this highly important part of the car deserved. That is, within the past few years. Before then, the comfort of the passenger was considered a matter of secondary importance, for the builder of the car was entirely engrossed in turning out a machine that combined reliability of performance with enduring qualities.

Things have changed considerably where body-making is concerned in the past few years, and some of the automobile manufacturers can now boast of as complete a body-making plant as is to be found in any of the old-established carriage factories, while the product of this department of the works ranks as high as anything of its kind to be had, either here or abroad. Two instances of this are to be found in the Franklin cars depicted on this page. The first, heading the column, is an attractive runabout model recently produced by the H. H. Franklin Manufacturing Company, Syracuse, N. Y. It is built on the chassis of the regular Franklin Model D as a foundation, and with its neat rumble seat and racy lines is a striking addition to the popular roadster type of car. It has a four-cylinder, 28-horsepower engine, selective change-speed gear, 105-inch wheelbase, and weighs 2,000 pounds. The second car is built on the same chassis and is a special town type owned by O. J. Gude, New York.

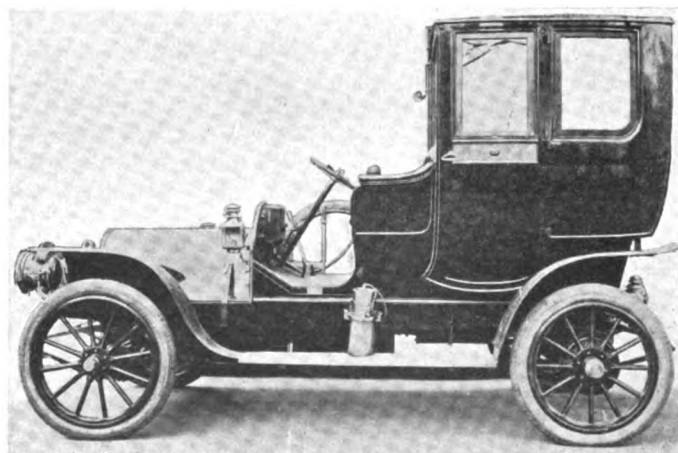

SPECIAL TOWN CAR BUILT ON MODEL D FRANKLIN CHASSIS.

### ELECTRIC VEHICLE CO. AT A STANDSTILL.

HARTFORD, CONN., Feb. 17.—On account of the failure of the main creditors of the Electric Vehicle Company to agree upon terms of reorganization, the receivers have been instructed to cut off all expenses. As a consequence most of the few remaining employees in the office have been laid off and the officers and engineers have been released.

Since the time of closing on December 10, 1907, a considerable number of the office employees have been kept to attend to closing up the business, to make a complete inventory, and to keep the accounts of the receivership. There has been also a small force in the repair department and a few men were employed in making repair parts. The latter have been entirely cut off and the repair department cut down with the possibility of the doors being shut entirely.

It seems particularly unfortunate that the company should be compelled to close its doors at this time, because, from a sales and manufacturing standpoint, the prospect was never so bright as at the close of the New York shows. It is a noteworthy fact that the sales at the recent shows exceeded those of any past year, and the sales manager, Mr. Kyte, stated that practically the entire output for the year had been disposed of, and when the crash came it was, of course, necessary to cancel all of these orders. It was also a disappointment to the American trade because of the fact that the electric transmission on the 48-horsepower touring car, perfected after years of hard work by J. B. Entz, is the only car of its kind on this side of the Atlantic, and it is confidently believed that the system is superior to any produced abroad. Ten cars of this type were built during the past year and all are in successful operation, the most of them being sold in New York, Toledo, and elsewhere.

The receiver, Mr. Nuckols, stated that nothing definite can be said of the future of the company. It may be that the creditors and stock and bondholders will not be able to agree upon terms of reorganization, in which case the plant will go to the highest bidder. But, on the other hand, it is hoped that a reorganization may be consummated and the business continued along established lines. With a reasonable capitalization there is little doubt that success would be assured.

### HARTFORD RECEIVERS MAKE REPORTS.

HARTFORD, CONN., Feb. 17.—The report of Albert L. Pope, as receiver for the Pope Manufacturing Company, to the Superior Court, shows total cash receipts of \$141,000 for the month of January, which with \$11,000 cash on hand, makes a total of \$152,000. This consists of the proceeds of accounts collected, receiver's sales, deposits on cars ordered, receipts from receivers in Massachusetts, Maryland, and the Pope Motor Car Company, Toledo, O. During the same time the disbursements totaled \$129,000, and the accrued liabilities of the receiver for materials, supplies, payrolls and miscellaneous items, came to \$44,000. The balances due to the receiver from receivers in other States total \$14,000, while the accounts receivable from sales made reach \$94,000, composed of \$97,000 as per the December report, plus sales of \$129,000 during January, less the cash receipts during that month. There is also due the Hartford receiver for transfer of materials to other districts, some \$6,000.

In their report for the month of January, Halsey M. Barrett and Henry W. Nuckols, as receivers for the Electric Vehicle Company, show receipts as follows: Collections, \$6,300; sales, \$7,500; collections on receiver's account, \$3,800; Selden royalties, \$9,700, these sums with a few other small items making a total of \$38,000 for the month. Against this the disbursements for payrolls and the like total \$16,000, showing a cash balance on hand of close to \$22,000.

### PLAN TO REORGANIZE ROYAL COMPANY.

CLEVELAND, Feb. 17.—The Superior Savings & Trust Company, receiver of the Royal Motor Car Company, has made public the result of the findings of a special committee of three recently invited to suggest a plan for the reorganization of the company. This committee consists of Charles E. Adams, vice-president of the Cleveland Hardware Company; S. F. Haserot, president of the Haserot Canneries Company, and formerly chairman of the board of directors of the Royal Motor Car Company, and F. A. Scott, secretary and treasurer of the Superior Savings & Trust Company. The court appointed J. D. Cox, formerly president of the Cleveland Twist Drill Company; C. C. Bolton, formerly of the M. A. Hanna Company, and Ambrose Swasey, vice-president and treasurer of the Warner & Swasey Company, as appraisers to fix the value of the plant, and acting upon the report of the latter, the special committee of three recommend that a meeting of the creditors be called immediately to consider a plan for the reorganization of the company, it being proposed to capitalize the indebtedness.

The appraisers report the total assets of the company, consisting of realty, plant, equipment, machinery, parts and complete cars, at \$398,000 as a going concern. The accounts receivable and other items, including membership in the A. L. A. M., bring this up to \$444,000, while the liabilities total \$511,000, showing an excess of the latter over assets of \$67,000. The special committee, among its other findings, states that in case of dissolution, the creditors will lose some \$80,000 representing the company's equity in its realty, now subject to foreclosure at any time owing to default in payments to the mortgagee, and a very large percentage of the value of the parts and unfinished cars, appraised at \$98,000, as the latter would sell for little or nothing in their present state. It also finds that there are about 400 creditors, 235 of which hold claims of \$100 or less, and it is recommended that the latter, amounting to about \$6,000, be paid off by the receiver. The plan calls for the issue of preferred stock to the remaining creditors and their control of the company until 50 per cent. of such preferred stock shall have been retired, then a limited representation of the old stockholders.

### NEW CATALOGS THAT HAVE BEEN RECEIVED.

**New York Sporting Goods Company.**—Dealers in automobile accessories and motorcycle supplies will be interested in the new catalogue published by this house from their headquarters at 17 Warren street, New York. It is an attractive publication, showing all kinds of supplies for automobile purposes. The price list shows the net cost, the confidential quotations only being given to those who are legitimately engaged in the trade.

**Imperial Brass Manufacturing Company, Chicago.**—Practically all brass work employed in connection with an automobile being handled by this firm, the 1908 catalogue covers a very extensive field. Some of the more prominent articles in the well-produced and carefully illustrated catalogue are pumps, cocks and valves, lamps and lamp brackets, radiator and hood trimmings, and body fittings.

**Wright Cooler and Hood Mfg. Company, Chicago.**—Automobile radiators, mudguards, gasoline tanks, engine pans and garage floor pans form the chief items in the catalogue sent forth from this house. Illustrations are given of a number of standard lines in radiator construction and folding and stationary hoods.

**McCord & Company, Chicago.**—Force-feed lubricators are expected from a catalogue bearing the name of this firm, and are to be found the 16-page catalogue giving, in addition to a varied series of lubricators, some particulars of McCord radiators, gaskets and coiled wire belting.

## BRIEF ITEMS OF NEWS AND TRADE MISCELLANY

Realizing that Canada is becoming one of the best export fields open to the American manufacturer, the Studebaker Automobile Company, New York, of which C. F. Redden is general manager, will make an exhibit at Toronto, Ont., at the automobile show to open there on March 20.

D. P. Nichols & Co., 116-122 West Brookline street, Boston, Mass., are building for J. M. Duggan, a convertible limousine ambulance. This is a new departure in the ambulance line, being so designed that it has at all times the appearance of a stylish private car. When in use as an ambulance it is provided with a cot, pneumatic mattress and all necessary equipment, with room inside for two passengers besides the patient and cot; and when not arranged as an ambulance is a luxurious eight-passenger limousine. This car is intended for hospital and private service, where patrons wish to avoid the conspicuousness of an ordinary ambulance. Nichols & Co. are endeavoring to complete this car for exhibition at the Boston show, March 7-14.

Under the title of the "P. & H." Tire Company, a firm has just been organized to market the "P. and H." reinforced inner tube. The officers are: R. G. Howell, president; Paul H. Pelletreau, secretary and treasurer, and J. D. Prince, general manager. The new concern will open an office at 1,657 Broadway, New York. The "P. & H" tube is designed to reinforce the outer casing of the tire and differs from the regular inner tube in that it is reinforced with two layers of fabric laid in such a manner as to give the required elasticity. This reinforcement is said to give an increase of more than ten times the strength of the inner tubes now commonly used, thereby preventing blowouts, pinching and other prevailing troubles.

"While the West has always been a good field for automobiles, I believe that the Western sales for 1908 will eclipse those of previous years," says W. H. Van Dervoort, maker of the Moline car and auditor of the American Motor Car Manufacturers' Association. "Manufacturers, regardless of their locality, have conceded that the East held all automobile sales records, but I am confident the West will soon win this distinction. I do not say this without foundation. The West is in an unusually prosperous condition, especially the farmers. The farmers are more interested in automobiles than heretofore, and this class of buyers will purchase a large quantity of cars this year. The Western States are paying more attention to road improvement and consequently the highways will be in better shape for touring in 1908, which undoubtedly will increase the automobile sales."

"The demand by automobile manufacturers for special high-grade springs has compelled the Cleveland-Canton Spring Company, Canton, O., to increase its facilities in this department," says Secretary H. C. Haight of that concern. A new building has just been erected to be used exclusively for the manufacture of automobile springs and has been equipped throughout in a manner designed to meet the requirements of the most exacting designers for high-grade automobile springs. The company has carefully studied the use of vanadium steel, and springs made from this steel and other high-grade alloy steels will

be heated in special furnaces fitted with pyrometers and particularly designed for this work. A new testing machine has been added in this department, and improvements have been made in the fitting of springs, brought about by the purchase of a patented rolling machine exclusively used by the Cleveland-Canton Spring Company. The latter's plant has been running full time all through the recent commercial depression.

✓ At the annual meeting of the stockholders of the H. H. Franklin Manufacturing Company, Syracuse, N. Y., the following directors were re-elected: H. H. Franklin, A. T. Brown, W. C. Lipe, E. H. Dann, G. H. Stilwell, John Wilkinson and F. A. Barton. After the stockholders' meeting, the directors re-elected the following officers: President, H. H. Franklin; vice-president, G. H. Stilwell; secretary, F. A. Barton, and treasurer, H. B. Webb. In the evening the stockholders of the company were entertained at the Century Club by Mr. Franklin. In speaking of the year's business he said that the company sold its first car in June, 1902, the total for that year amounting to \$122,000, while in 1907 the sales came close to the \$4,000,000 mark, and in spite of the financial stringency orders kept up well during November and December, though the first fortnight of January was dull, but picked up again immediately after, the third week of that month showing an increase of 29 per cent. over the total of the two weeks preceding.

Nearly one-third, or 199 out of the 727 cars of the 1908 model already delivered by the Packard Motor Car Company, have been equipped with limousine bodies. This is a remarkable demonstration of the growing use of the automobile as an all-the-year vehicle. It is an encouraging sign in the automobile trade that such a large portion of the Packard sales should have been of cars with inclosed bodies. The condition shows that people who are buying these cars expect to remain autoists and are buying for comfort, utility and style. Many of them have both touring and limousine bodies, as the Packard limousine is interchangeable with the touring car body on the same chassis. A peculiarity of this demand is the attention paid to the tastes and wishes of women. The modern limousine must not only furnish protection against inclement weather, but it must be a thing of beauty. Its appointment, to the smallest detail, must be above reproach. Even the ultra-fashionable horse-drawn carriage is no criterion; the buyer expects greater refinement in a new limousine motor car than in any horse carriage.

### NEW AGENCIES ESTABLISHED.

Noblit & Fassett have succeeded Titman, Leeds & Company as Philadelphia agents for the Matheson and Pope-Hartford. The new concern has also taken over Titman, Leeds & Company's quarters, at the corner of Broad and Cherry streets.

During the present week the Bergdoll Motor Car Company will occupy its new three-story garage and salesrooms at the corner of Broad and Wood streets, Philadelphia. "Open House" will follow as soon as things can be whipped into shape. The Bergdoll concern handles the Welch, Imperial, Berliet and Benz cars.

Rose & Thompson, Incorporated, have purchased the interests of William H. Ulrich in the Yonkers (N. Y.) Auto Station, and have secured the sole agency in Westchester County for the Stearns, the C. G. V., and the Selden cars. The garage will be conducted in a thoroughly up-to-date manner, and a complete line of automobile supplies will be carried in stock.

The Wayne Automobile Company, Detroit, Mich., announces the establishment of 1908 agencies with the following houses: Frank A. Sanford, New York City; H. Francis Kane, Seattle, Wash.; Evans Motor Car Company, Minneapolis, Minn.; W. H. Demster Machinery Company, Kansas City, Mo.; Urch & Folsom, Ashland, Neb.; West Side Motor Company, Hamilton, O.; A. T. Wilson, Denver, Col.

The Factory Sales Corporation, 235 Randolph street, Chicago, has become the sales manager in the United States for the automobile devices manufactured by the Quincy, Manchester, Sargent Company, of that city. These devices are the Auto Clewrench and the Q. & C. Stanwood automobile step. George T. Briggs, who has been associated with the Quincy, Manchester, Sargent Company for the past four years, has identified himself with the Factory Sales Corporation.

The Witherbee Igniter Company, of New York, has just established a branch store at 720 Main street, Buffalo, for the sale of Witherbee batteries and Wico specialties, under the management of James Barkley. General Manager A. J. Fisk, who is now on an extended trip through the West, announces that it is the company's intention to establish a complete chain of branches, and that a more than ever vigorous advertising campaign will be mapped out by John B. Rowland, who will have charge of that particular part of the business.

### PERSONAL TRADE MENTION.

Cornelius Barrows, who represented the Fiat in Philadelphia for several years, has been appointed manager of the Fiat department of the Girard Motor Company, of that city, which concern recently secured the local agency for the foreign car.

B. C. Day, manager of the Winton branch at Chicago, is a modest personage, notwithstanding the fact that he was formerly an advertising solicitor. The extent of his natural reticence will be understood when it is related that until the other day his employers did not know that he is the son of Rear Admiral Benjamin F. Day, U. S. N., retired, of Glasgow, Va.

Announcement comes from Orange, Mass., that the Grout Bros. Automobile Company is preparing to enter on the manufacture of cars on a large scale, under the direction of Rossell Drisko, who has recently been appointed general manager. Mr. Drisko is a Boston man of wide experience in the automobile field, both as a salesman and a manufacturer. He was formerly manager of the Bay State Automobile Company, which built the Bay State Forty, and previous to that handled the Stevens-Duryea and the Queen, with the late F. F. Randall. He goes to the Grout plant with full powers, and his plans include the introduction of a number of new mechanical features.



INFORMATION FOR AUTO USERS

**Reliable Priming Valve.**—It frequently occurs that it becomes difficult to create sufficient suction when turning a motor over by hand, to cause it to start the aspirating nozzle of the carbureter, and to overcome this cause of trouble, J. H. Koontz & Company, Culver, Ind., are introducing an ingenious device which is adapted to be applied to the air intake of the carbureter, so as to shut this off



KOONTZ RELIABLE PRIMING VALVE.

temporarily when cranking. This is claimed to be superior to the method of priming by "tickling" the carbureter, as there is no tendency to flood or cause an overrich mixture, as it is possible to release the new priming valve the moment the motor starts. The details of this device as well as the manner of its application will be plain from the accompanying cut.

**Brown Valve Grinder.**—The object of this ingenious tool, the details of which are shown by the accompanying illustration, is to render the operation of grinding in valves easy and efficient, by saving time and making the work more satisfactory than is possible by make-shift methods. It is the product of the Brown Company, Syracuse, N. Y., who also make other specialties for the auto-



BROWN VALVE-GRINDING SET.

ist and repair man, and has been designed to be as simple and compact as possible, it only being necessary to remove the handle and the driver to pack it away in the tool box. In use the Brown grinder is held with the left hand, while a horizontal force is applied with the right, this imparting to the screw-driver, by means of a pinion and rack, a semi-rotary motion. Combined with the

grinder is the valve lifter, consisting of a heavy brass, helical spring, equipped at either end with a bearing and clamp fixture. To accommodate varying stem diameters the clamp is provided with two set screws, which when adjusted are left that way, the thumb screw being used for holding purposes. The only pressure required on the tool is that required to overcome the force of the lifter spring, the lifter being clamped to the valve stem before beginning the operation of grinding. The lifting action disintegrates all particles of compound previously rubbed on the valve faces and seat and introduces a factor of safety which makes the operation easy and certain for the veriest tyro. The Brown valve grinding set includes these tools and a box of special Brown grinding compound. The same firm also manufactures a handy compressometer for determining the compression of a motor. It consists of a well-made 100-pound gauge with a maximum hand that remains at the highest point of compression reached when turning the motor over. It is used by screwing into the cylinder in place of the spark plug.

**Battery Power Gage.**—The Hoyt Electrical Instrument Works, Penacook, N. H., who are the manufacturers of the combined type of voltmeter and ammeter for dashboard mounting on a car,



HOYT BATTERY POWER GAGE.

recently described in these columns, are now bringing out an instrument that they term a "Battery Power Gage" and which will be found of considerable value by every autoist who uses batteries of any kind for ignition, as it gives him a knowledge of the condition of the car's supply of current every moment it is in use. It is, in fact, a high resistance voltmeter, designed to be permanently connected in shunt on the low-tension side of the ignition system, that is, on one side to the wire leading from the battery to the coil box, and on the other to the ground, so as to bridge it across the battery and coil circuit. As soon as the switch is closed the gage indicates its condition as revealed by its voltage, and gives that indication continuously as long as the switch remains closed or there is any current in the battery. A broken connection would immediately be shown by the pointer dropping to zero, while a poor connection making contact but part of the time would be revealed by the fluctuation of the hand. The amount of life remaining in a set of batteries can also easily be determined, as a new dry-cell gives 1.2 volts, and the set of six will make the reading 8.2 or 9 volts. It is also applicable to storage cells, as the volt-

age is an even more certain indication of their condition. When this drops to 5 volts, it is time to discard the cells. Owing to its high resistance, the gage itself has no effect on the life of the cells. Its appearance may be judged of from the accompanying line cut.

**Ruprecht Corrector.**—This is an alternating current rectifier of foreign make, of which the Auto and Supply Company, 406 Cuyahoga building, Cleveland, O., are the manufacturers' United States agents. The corrector is absolutely simple, as it has no winding or coils, makes no sparking or glare and is started or stopped merely by opening a switch. In case of current failure, the battery cannot discharge through the corrector, and the latter will immediately resume operations automatically upon the renewed flow of the current. The upkeep and attention required are practically negligible. The corrector consists of two poles, one of aluminum and the other of a composition metal, immersed in a chemical solution contained in a glass jar 5 inches in diameter. The poles are suspended from a slate top, which also carries all the connections. It is particularly designed for charging ignition accumulators, and as it has a capacity of 5 amperes, will recharge three sets of cells simultaneously.



RUPRECHT CORRECTOR.

**Soda and Potash Kettles.**—For quickly, thoroughly and economically cleaning oil, grease and chips from all sorts of newly made small parts, such as screws, nuts, bolts, gears and the like, it is customary to dip them into a hot, alkaline solution for a short time, and to make this process convenient and efficient the Gray & Prior Machine Company, 86 Suffield street, Hartford, Conn., make gas-heated kettles of the type shown by the accompanying illustration. The solution most commonly used consists of about half a pound of common washing soda per gallon of water, the

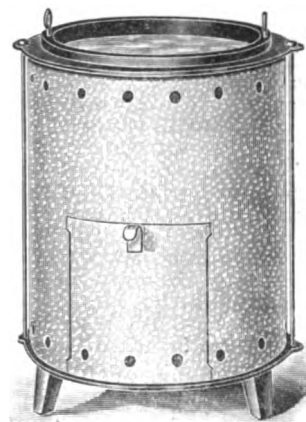

GRAY & PRIOR SODA KETTLES.

parts being cleaned by placing in a small perforated metal basket and then lowering into the hot solution. The first cost of these kettles is considerably lower than that of the steam-heated type, and they do not require any expensive auxiliaries or installation. The gas burner for supplying the heat consists of two concentric rings, supplied by independent gas cocks so that either may be used at will, the larger taking 15 cubic feet of

gas per hour and the smaller five, the latter being sufficient to keep the kettle hot. These kettles are listed in one size only, holding 10 gallons of solution. They will be found particularly adapted for the use of repair shops, garages and the like, where gasoline is usually employed for this class of cleaning, and will not only effect a great saving over such a method, but are far safer.

**Auto-Marine Spark Plug.**—This is a new plug, one of its distinctive features being an ingenious quick-opening and locking device, the operation of which will be understood at a glance upon reference to the accompanying illustration. It is being manufactured and marketed by Legnard Brothers, Waukegan, Ill., and a patent has been applied for to cover this as well as its other points of superiority. By merely giving the insulated handle forming part of the plug one-quarter turn it is possible to lift everything but the shell out of the cylinder, examine and clean the points, test and return to place with the motor running, without the need of tools and without any danger of shock. The ground taper fit and the locking device, con-

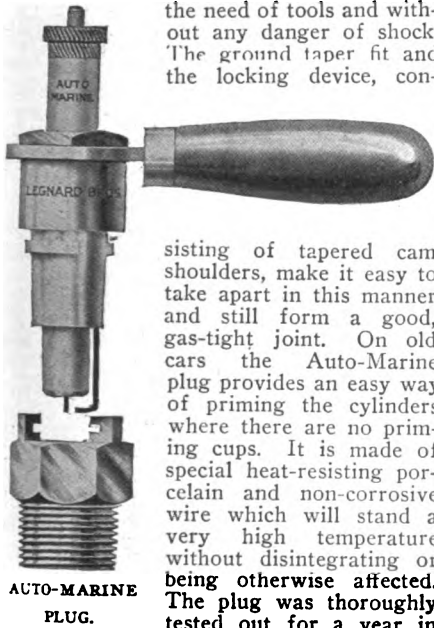

sisting of tapered cam shoulders, make it easy to take apart in this manner and still form a good, gas-tight joint. On old cars the Auto-Marine plug provides an easy way of priming the cylinders where there are no priming cups. It is made of special heat-resisting porcelain and non-corrosive wire which will stand a very high temperature without disintegrating or being otherwise affected. The plug was thoroughly tested out for a year in both air and water-cooled

motors before being placed on the market, so that the makers are confident that it will live up to every claim made for it, as no form of test that either the makers themselves could think of nor their friends or critics suggest was omitted in trying it out during that period. It is manufactured in all standard threads and sells for \$1.50.

**The Le Python Horn.**—This represents quite a radical departure from current designs in automobile horns, as will be apparent at a glance at the illustration. In place of the usual spreading bell mouth, which not only serves as a receptacle for dirt and flying particles, and which also offers such an area facing forward that the wind resistance at 40 miles an hour and over is in excess of that of the horn bulb, there is a small globe-shaped end situated within the spiral of the horn and perforated to permit the escape of the sound. No matter how fast the car travels, there is no back pressure on the bulb. Another feature of this horn is its peculiar, long-drawn-out tone, caused by the air passing through the gradual curves in the coils of the spiral. It can be readily

attached to the dash or side of the frame and does not interfere with the mud-guard or the raising of the hood, as it measures only three inches through.

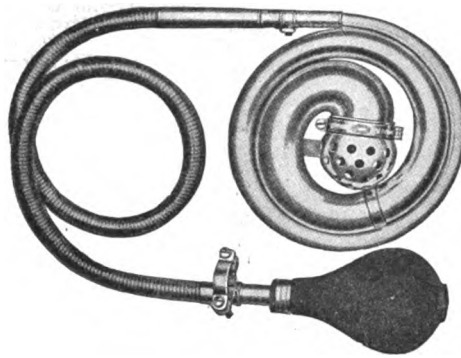

LE PYTHON HORN AND BULB.

The bracket is so constructed that the horn complete may be instantly detached from the car for washing or similar purposes, although the design is such that it is next to impossible for water to get into it. The Le Python is of French manufacture and is being extensively adopted by foreign makers as part of the standard equipment of their cars. It is handled in this country by the Post & Lester Company, Hartford, Conn., who are exclusive agents for a large number of both foreign and American auto accessory specialties of different kinds.

**Lipman Tank Gauge.**—“It is a necessity, not a luxury,” say the makers of this new device, the Beloit Supply Company, of Beloit, Wis., and this is something with which

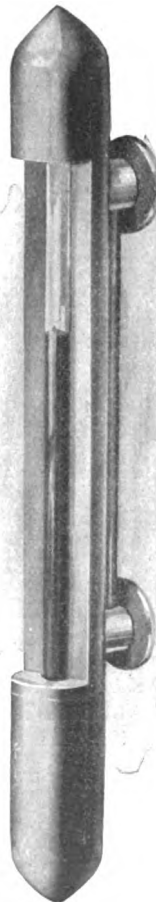

LIPMAN TANK GAUGE.

the average autoist will readily agree, as a convenient means of ascertaining just how much fuel there is in the tank at any given time, is something that is really needed on every car. The Lipman gauge is simplicity itself, as it works on the principle of displacing the air and thus has no moving parts of any nature. It may be placed above or below the tank level, or at either side, and only requires to be perpendicular. Connection to the tank is made by a flexible copper tube, which enters the tank at the top and extends to within half an inch of the bottom. As the gasoline rises in the tank it naturally does likewise in the tube, forcing the air in the latter into the bulb of the gauge, the pressure thus created forcing the liquid of the gauge upward in proportion to the depth of the fuel. As the latter recedes the indicating col-

umn of the gauge does likewise and always in the same proportion. Connection is made from behind, so that nothing shows on the dash but the gauge, as illustrated in the accompanying cut.

**Protection Bumper.**—Ever since the present type of car came into vogue the necessity for something that would prevent the radiator and headlights from feeling the effects of contact with suddenly backed wagons, other machines in the garage and similar accidents, has been apparent to every autoist. To meet this demand, J. H. Sager & Company, Rochester, N. Y., manufacturers of the well-known Sager equalizing springs, are now placing on the market a simple and ingenious device known as the “Protection Bumper,” the arrangement of which will be apparent from the accompanying illustration, showing it ready to put on a car. The attachment is practically universal, as it is made adjustable and thus can be ap-

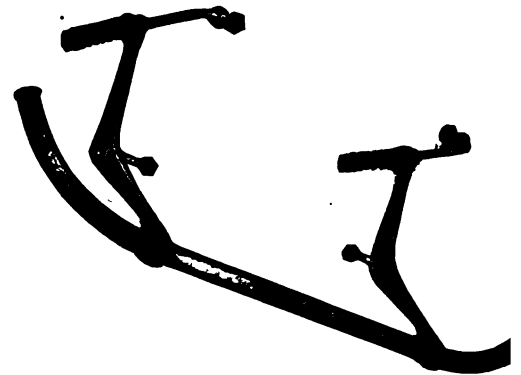

SAGER'S PROTECTION BUMPER.

plied to any car without trouble. It will be evident that it not only serves as a protection to the lamps and radiator, but also prevents a pedestrian getting under the wheels of the car. The Protection Bumper is made in two styles, black and brass, the former being designed to be painted to match the finish of the car. The latter is not a brass-plated tube, but is made of steel-lined brass tubing. The arms holding the tubing are raised to give extra protection and are made of special metal, highly polished. The rear ends of the arms rest upon two coiled springs encircling the lower end of an L-shaped stud bolt, securely fastened to the frame. These springs absorb the shock of a collision without damage to the bumper or the car.

**Acetylene Signs.**—An extremely attractive form of night and day sign adapted to be lighted by acetylene gas has just been perfected and placed on the market by the Avery Portable Lighting Company, 18-22 Martin street, Milwaukee, Wis. It is equipped inside with two small acetylene burners which are supplied with gas through a small pipe attached to the bottom of the sign. The latter can be attached to the back of the car or to the radiator, by means of screws, it having been designed particularly with this in view, being a substitute for the tail-light when placed on the rear. The pipe line leading from the Autogas tank to the headlights can be easily tapped and an additional connection made with a pipe line leading to the sign; the front of the latter is made of stained glass, the lettering being white on a red background, the letters being about two inches high, so that they are plainly visible by day. The night effect is striking.

INDEX TO ADVERTISERS

Acetylene Gas Illuminating Co. 65
Acme Motor Car Co. 70
Adams Co. 70
Add-Wear Auto Tire Sleeve Co. 71
Aerocar Motor Co. 70
Ajax-Grieb Rubber Co. 71
Almy Water Tube Boiler Co. 79
Am. Brass & Alum. Works. 67
Am. Locomotive Car Co. 78
Amer. Motor Car Sales Co. 78
Anderson Forge & Machine Co. 67
Angier Co. 90
Apperson Bros. Automobile Co. 89
Ashtabula Bow Socket Co. 68
Atlas Motor Car Co. 102
Auburn Automobile Co. 70
Audel & Co., Theo. 73
Aurora Motor Works. 96
Austin Automobile Co. 78
Auto Pump Co. 75
Auto & Supply Co. 65
Autocar Co. 93
Automobile Supply Co. 64
Automobile Utilities Co. 64
Auto-Shine Co. 65
Auxiliary Spring & Ventilating Button Co. 68
Avery Portable Lighting Co. 90
Baldwin Chain & Mfg. Co. 67
Barnnd-Johnston Auto Supply Co. 68
Barnett Drop Forging Co. 83
Beaver Mfg. Co. 65
Behen-Faught Motor Car Equipment Co. 65
Beloit Supply Co. 92
Biddle & Smart Co. 68
Blaser Mfg. Co., M. E. 68
Bliss-Chester Co. 64
Blomstrom Mfg. Co. 83
Boker & Co., H. 67
Borbein Auto Co. 73
Bosch, Robert 101
Boston Auto Gage Co. 73
Bowers & Co., F. E. 77
Bowler & Co., S. F. 64
Boyle & Co., John. 102
Brennan Motor Co. 88
Bridgeport Vehicle Co. 73
Brown, Wm. W. 64
Brownell Motor Co., F. A. 66
Brush Runabout Co. 94
Buckeye Jack Mfg. Co. 90
Buckeye Mfg. Co. 70
Buffalo Carbureter Co. 85
Bullard Specialty Co. 75
Buob & Scheu. 68
Cadillac Motor Car Co. 70
Cameron Car Co. 85
Canton Drop Forge & Mfg. Co. 67
Capitol Auto Co. 68
Champion Co., A. 81
Clark, E. S. 64
Cleanola Co. 74
Coes Wrench Co. 60
Comploir d'Innovations pour Automobiles 83
Connecticut Steel & Wire Co. 68
Conn. Tel. & Elec. Co. 93
Continental Caoutchouc Co. 71
Continental Motor Mfg. Co. 71
Corbin Motor Vehicle Corp. 91
Corcoran Lamp Co. 71
Cornish-Friedburg Motor Car. 70
Correspondence School of Motor Car Practice. 71
Cotta, Chas. 75
Cowles & Co., C. 64
Crown Soap Co. 86
Cullman Wheel Co. 67
De Luxe Motor Car Co. 70
Detroit Steering Wheel Co. 89
Diamond Chain & Mfg. Co. 67
Diamond Rubber Co. 78
Dietz Co., R. E. 76
Dixon Crucible Co., Joseph. 74
Dorris Motor Co. 91
Dover Co., Geo. W. 63
Dover Stamping & Mfg. Co. 88
Dow Portable Electric Co. 65
Echo Horn Co. 88
Eclipse Machine Co. 64
Edgar Mfg. Co. 64
Edmunds & Jones Mfg. Co. 64
Eldredge Electric Mfg. Co. 74
Ellsworth, J. M. 110
Elmore Mfg. Co. 99
Empire Automobile Tire Co. 75
Empire Wheel Works. 68
Excelsior Supply Co. 77
Fairmount Engineering Works. 70
Firestone Tire & Rubber Co. 71
Fisk Rubber Co. 87
Forest City Motor Car Co. 87
Franklin Mfg. Co., H. H. 107
Fry, T. C. & W. L. 64
G & J Tire Co. 87
Garford Motor Car Co. 70
Gearless Transmission Co. 89
Geisler Bros. 66
Gemmer Mfg. Co. 86
General Accumulator & Battery Co. 65
Gibney & Bros., Jas. L. 65
Gilbert Mfg. Co. 77
Goodrich Co., B. F. 68
Gray-Hawley Mfg. Co. 88
Grout Bros. Auto Co. 99
Ham Mfg. Co., C. T. 86
Hans, Edmund E. 87
Hardy Co., The R. E. 78
Harris, Chas. J. 87
Harris Oil Co., A. W. 73
Hartford Suspension Co. 88
Hatcher Auto Parts Co. 66
Hatfield Motor Vehicle Co. 70
Haws, Geo. A. 78
Haynes Automobile Co. 70
Healy Leather Tire Co. 71
Heinze Electric Co. 84
Hercules Auto Specialty Co. 84
Herz & Co. 66
Hess-Bright Co. 67
Hicks Speed Indicator Co. 82
Hoffecker Co. 64
Hoffman, Geo. W. 64
Holley Bros. Co. 92
Holsman Automobile Co. 76
Hopewell Bros. 71
Hotel Gilsey 82
Hotel Pierrepont 82
Hotel Piney Woods Inn. 82
Hotel Richmond 82
Hotel Tampa Bay 82
Hotel Tuller 82
Howard Motor Works. 80
Hoyt Electrical Ins. Co. 103
Imperial Motor Car Co. 70
Indestructible Steel Wheel Co. 68
Jackson Automobile Co. 70
Jeffery & Co., Thos. B. 105
Jeffery-Dewitt Co. 68
Jencick Motor Mfg. Co. 86
Jenkins Specialty Mfg. Co. 84
Johnson Sporting Goods Co., I. 73
Jones Speedometer 65
K. W. Ignition Co. 65
Kimball Tire Case Co. 74
Kissel Motor Car Co. 97
Kokomo Electric Co. 92
Konigslow, Otto 67
Koontz & Co., J. H. 90
Lansing-Mahon Press 91
Lavalette & Co. 65
Lear Automobile Co., Oscar. 70
Leather Tire Goods Co. 71
Limousine Carriage Mfg. Co. 68
Lipman Mfg. Co. 64
Lobe Pump Co. 67
Locke & Co. 81
Lockwood Bros. 91
Logan Construction Co. 70
London Auto Supply Co. 68
Long Mfg. Co. 86
Macbeth-Evans Glass Co. 91
McCord & Co. 77
Manhattan Electrical Sup. Co. 64
Manhattan Storage Co. 65
Maple City Mfg. Co. 68
Mason, John A. 68
Masury & Son, John W. 98
Mathewson Motor Car Co. 100
Mayo Radiator Co. 68
Meyers & Son, C. G. 98
Merchant & Evans Co. 85
Merritt & Co. 64
Metzger, C. A. 73
Michelin Tire Co. 71
Midgeley Mfg. Co. 67
Miller, Chas. E. 91
Mitchell Motor Car Co. 70
Model Automobile Co. 104
Moline Automobile Co. 97
Montgomery-Washburn Co. 81
Moon Motor Car Co. 70
Morgan & Wright. 92
Mosler & Co., A. R. 66
Moss Photo Engraving Co. 100
Motor Car Co. 86
Motor Car Equipment Co. 75
Motz Clincher Tire & Rub. Co. 71
Muller, Albert 66
Muttly Co., L. J. 68
Myers Auto Top Co. 68
National Auto Accessories Co. 65
National Battery Co. 81
National Motor Vehicle Co. 103
Neustadt Auto & Supply Co. 88
Never-Miss Spark Plug Co. 85
New Process Rawhide Co. 90
N. Y. & N. J. Lubricant Co. 90
Nordyke & Marmon Co. 70
Northway Motor & Mfg. Co. 76
Nuttall Co., R. D. 67
Oakland Motor Car Co. 111
Ofeldt & Sons. 64
Olds Motor Car Co. 70
Pacific Tucking & Mfg. Co. 64
Packard Electric Co. 73
Packard Motor Car Co. 108
Palmer & Singer Mfg. Co. 109
Parish & Bingham Co. 67
Parker, Stearns & Co. 86
Pease & Sons, S. C. 68
Penn. Auto Motor Co. 70
Perfection Grease Co. 85
Peugeot Freres 67
Pfanstiel Elec. Laboratory. 64
Picrome Hide Co. 67
Pierce Co., Geo. N. 67
Pioneer Engine Co. 70
Pioneer Brass Works. 67
Pirelli & Co. 71
Portland Garage 71
Precision Appliance Co. 65
Prest-O-Lite Co. 74
Progressive Mfg. Co. 77
Quinby Co., J. M. 68
Raimes & Co. 68
Rainier Co. 71
Rauch & Long Mfg. Co. 96
Reeves Pulley Co. 66
Remy Electric Co. 65
Richardson Engineering Co. 66
Robert Instrument Co. 64
Robinson & Sons Co. 68
Rock Island Tool Co. 90
Ross Gear & Tool Co. 67
Royal Equipment Co. 81-85
Rubay, Leon 81
Rushmore Dynamo Works. 98
Salisbury Wheel & Mfg. Co. 64
Samson Leather Tire Co. 71
Sanford Mfg. Co., F. C. 66
Saxon Lamp Co. 65
Selden Motor Vehicle Co. 95
Shawver Co. 65
Smith Mfg. Co., R. H. 83
Smith & Sons, S. 79
Spacke Machine Co., F. W. 81
Spare Motor Wheel of Am. 63
Speed Changing Pulley Co. 94
Spicer Universal Joint Mfg. Co. 67
Spittdorf, C. F. 65
Sprague Umbrella Co. 84
Springfield Metal Body Co. 68
Standard Automatic Lub. Co. 65
Standard Co. 94
Standard Roller Bearing Co. 67
Standard Welding Co. 81
Stanley, John T. 96
Steam Carriage Boiler Co. 70
Stearns Co., F. B. 101
Stevens-Duryea Co. 69-75
Stewart & Clark Mfg. Co. 69-75
Stitch-In-Time Vulcanizer Co. 79
Streator Motor Car Co. 67
Stret Machine Co. 65
Studebaker Automobile Co. 90
Success Auto Buggy Co. 71
Supplementary Spiral Spring. 92
Swinehart Clincher Tire Co. 83
Thomas Motor Co., E. R. 80
Thompson Sons Co., J. P. 71
Tray Plate Battery Co. 85
Trebart Gas Engine Co. 71
Tucker, C. F. 64
Turner Brass Works. 67
Two-Spot Mfg. Co. 94
Uncas Specialty Co. 74
Veeder Mfg. Co. 93
Walker Mfg. Co., E. C. 79
Warner Instrument Co. 98
Warner Pole & Top Co. 68
Watt-Detroit Carbureter Co. 79
Waukesha Motor Co. 81
Wayne Automobile Co. 71
Weed Chain Tire Grip Co. 75
Welch Motor Car Co. 90
Western Motor Car Co. 85
Western Elec. Instrument Co. 89
Wheeler & Schebler 104
White Co., The. 106
Whitney Mfg. Co. 83
Winton Motor Carriage Co. 112
Wing Co., Chas. 68
Witherbee Igniter Co. 73
Wyman & Gordon Co. 63
York Motor Car Co. 75

FOR UNMATCHABLE QUALITY BUY COES STEEL HANDLE MODEL WRENCH

THE WRENCH for Automobilists

High-grade quality in every detail of design, material, workmanship and up-to-date improvement. Excellence with extremely reasonable cost.

- NON-BREAKABLE CASTINGS
NON-STRIPABLE THREADS
NON-TROUBLESOME PARTS

QUALITY

Through and Through.

Look for the name—COES



70 years splendid reputation worthy maintained right up to the present time as the World's Best Wrench Makers. Write for "Wrench Book" free.

COES WRENCH CO., WORCESTER, MASS.

# THE AUTOMOBILE

## LONG ISLANDERS HAVE CONVINCING ECONOMY RUN

OUT of twenty-three automobiles participating Tuesday, February 25, nineteen finished the Mid-winter Economy Run of the Long Island Automobile Club, from Brooklyn to Amagansett Bay and return, distance 234 miles, in the time limit of eighteen hours. Of the four failing to come up to the reliability standard, one, the Lozier, driven by David Mahaney, was wrecked as the result of skidding on a blind turn. Three only were eliminated by mechanical trouble. Considering the condition of the roads, the reliability of the contestants was excellent, many of the cars finishing five to seven hours before the time limit after a run unmarked by much incident.

Which of the nineteen is the best car remains to be determined. Reliability is only a qualifying condition. The winner, on the club's basis of selection, is the car having carried its load at the lowest cost per head for fuel and oil. To determine this the contents of the tanks must be measured with care. It is not a difficult operation, but is one that should be carried out conscientiously, and the club officials preferred Wednesday to delay the announcement rather than risk any mistake in their calculations.

Competition for the three trophies will be keen.

Certain of the drivers declare they have covered the 234 miles on eight gallons of gasoline and less than a quart of oil. The cost by railroad from Brooklyn to Amagansett Bay and return is \$5.28 on an ordinary ticket and \$4.20 with a mileage ticket. Taking the consumption of the most economical cars at ten gallons of gasoline and two quarts of oil—the probabilities are that it will be lower—the total fuel cost for transporting five passengers a distance of 234 miles works out at \$3, or 60 cents per head.

At 6 o'clock Starter Wagner sent away the first of 23 competitors, a single-cylinder Cadillac piloted by Joseph D.

Rourk. A few minutes later Claud Hosley drove a 20-horsepower Maxwell over the line, and at odd intervals the remainder of the competitors followed, the last to leave being a six-cylinder Winton. They were a representative lot of American cars, comprising such makes as Pope-Hartford, Hol-Tan, Lozier, Franklin, Haynes, Acme, Cadillac, Pullman, Mora, Studebaker, Rambler, American Mors, Maxwell, Frayer-Miller, Winton, Stevens-Duryea, Thomas Detroit, and Buick.

Land's End to Land's End, the extremities being Brooklyn and Montauk Point, had been the original route. On measuring up the distance, however, it was found that 234 miles would be covered if the cars stopped short at Amagansett Bay, and in the interests of all it was decided to cut off the run to the end of the narrow strip of land with Montauk Point as its appendix.

The previous evening every car entered for the run had been given a measured supply of gasoline and lubricating oil, verified by an observer from a rival car, supplied with a set of cards on which were to be recorded its passage at the outward checking stations, starting and finishing time, and fuel and oil used. Therefore, when the start was

given, all that the driver had to concern himself about was reaching Amagansett Bay and returning to the clubhouse that evening by 9 o'clock with the least amount of consumption of gasoline and lubricating oil. The winner would be the car having taken its passengers over the 234 miles with the least cost per passenger, fuel and lubricating oil at 25 cents and \$1 per gallon alone being taken into account in making awards.

Looked at critically, there is some reason for objection to the basis on which the awards were made, for every type of car had to operate under the one general rule, and though each carried its full quota of passengers according to cata-

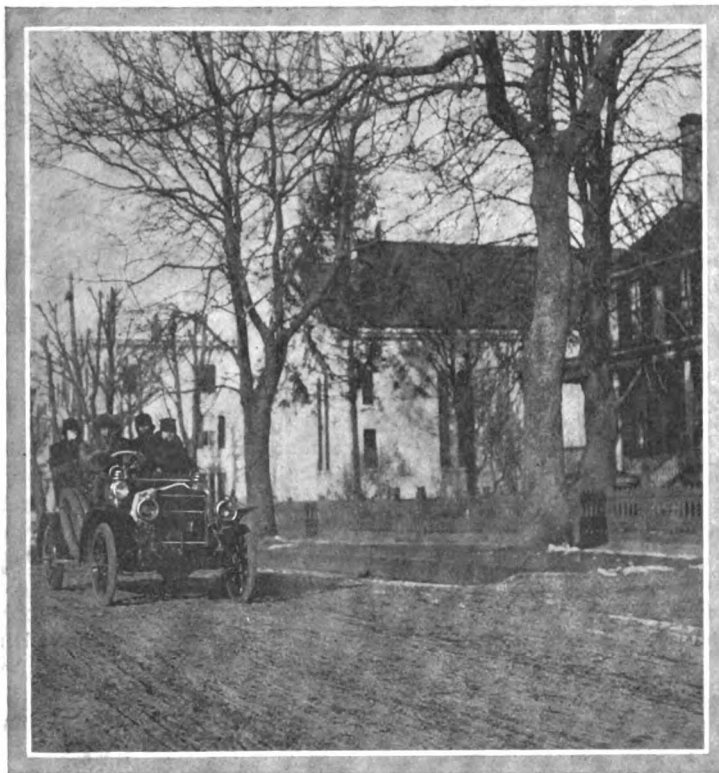

MAXWELL PASSING BABYLON, FIRST CHECK ON LONG ISLAND RUN.





PHOTOGRAPHING EARLY START WAS MOST DIFFICULT.

logue specifications, there was a great amount of variety. Thus the little single-cylinder Cadillac, the lowest-powered car in the test, had four persons on board; a big six-cylinder Acme, with more than four times the horsepower of the one-lunger, being fitted with a runabout body, also carried but four people. A small Buick, with open touring body, carried five people; an elegant American Mors with limousine body and windshield also had to divide its fuel and gasoline cost by five. With an icy breeze blowing across the unprotected island, there was no doubt as to which car offered the better method of travel; it was equally certain which, under ordinary conditions of operation, would have the heavier costs account.

Though recognizing that there were inequalities in the system on which awards were based, the committee believed that the wintry weather would tend to even up chances. With a heavy layer of snow on the ground and some rough going at the eastern end of the island, there were likely to be some cases of elimination from mechanical difficulties, and the heavily loaded, powerful cars were likely to see their gasoline supply diminish at an unusually rapid rate. As an object lesson on reliability and a demonstration of the cost of automobiling under ordinary winter conditions the run was of the highest value. The thoroughly earnest and businesslike manner in which every detail was attended to by the club officials served to enhance that value.

With but one or two exceptions every car taking part in the run was identical with those sold daily to the public or used by owners for ordinary touring. Though economy was the criterium, few thought it necessary to make any changes on their carbureters or to add the auxiliary air inlet which usually plays such an important part in limited fuel tests. A box on the running board for lubricating cams, and one more



CHECKING AT BABYLON—FRANKLIN IN FOREGROUND.

spare tire than is usually carried was the extent of the change on the majority of the cars. Hugo C. Gibson, the English expert for the Selden interests, was the object of numerous questions concerning a modified radiator surmounted by an ordinary house radiator escape cock, and a gasoline gauge projecting through the bonnet of the car.

On the outward run to Amagansett Bay each car had to report to the four checking stations; but when the easterly point had been reached the run home could be undertaken over any road the driver preferred. Instead of the usual type of checking card to be signed in a space provided, each card had a combination set of figures on which any hour and minutes could be punched. The same system was adopted on the gasoline and fuel cards. Time spent on the road and between checking stations in no way entered into the consideration for awards, the only time provision being a return to the clubhouse at 9 P. M., no cars being checked in before that hour, and no account taken of arrivals after midnight.

#### What Occurred on the 234-Mile Journey.

Road conditions were such as to make the test of real value in proving the economy or otherwise of an automobile. While slightly worse than the average likely to be met with in a year's touring through the Eastern States, conditions were not so bad as to rob the run of value as an economy demonstration. On the outward trip the surface was generally hard and rutty, with but a small amount of snow.

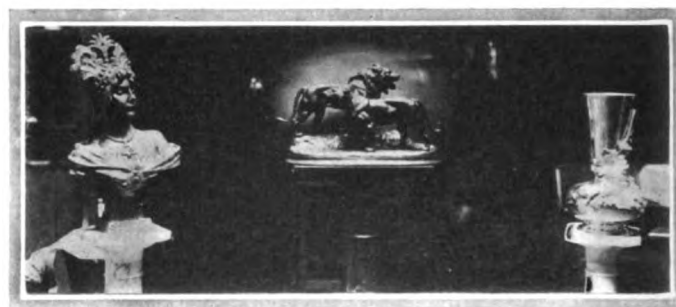

TROPHIES FOR THE SUCCESSFUL PARTICIPANTS.

When the homeward run was commenced the thaw had softened the surface so much that there was a considerable amount of lost traction and drivers had not always an easy task in keeping their cars on the road.

The greasy surface was partly responsible for the only serious accident of the day. After checking in at Southampton, No. 20 Lozier, driven by David Mahaney, unexpectedly found an express wagon blocking the road on a blind curve. To avoid a collision the automobile driver swerved suddenly, ran on the sidewalk, crashed into a telegraph pole, smashed both left wheels and bent the front axle. The passengers suffered nothing worse than a shaking. Mahaney telephoned to New York for wheels, but was unable to finish within the time limit.

Before noon No. 5 Haynes, driven by W. E. Shuttleworth, retired from the contest with a broken rear axle. Hugo Gibson's Buick dropped out of the competition as the result of the collapse of the patent wheels which the owner was experimenting. An effort to obtain a perfect set from New York was not successful. The Hol-Tan runabout, driven by Neilson, developed differential troubles on the outward run, was reported to be in further difficulties on the way home, and had not appeared at the garage at the closing hour, Tuesday midnight. For a time it appeared as if the little single-cylinder Cadillac would be eliminated, a broken wheel having caused it to lose a considerable amount of time. At 10:30, however, it reported at the clubhouse, and was consequently entitled to enter with the others for the economy classification.

Ideas differed on the method of driving in an economy competition. Half a dozen rushed over the course at such a speed that they were back in Brooklyn at 4 o'clock. Three cars, a six-cylinder Acme, a Thomas-Detroit, and a Stevens-Duryea, had entered the garage before 5 o'clock. C. S. Arnold's Pope-Hartford, a Lozier, Pullman, two Acme cars and a Mora had finished the run shortly after 6 o'clock. The early finish benefited them nothing, no official recognition of arrival being made before 9 o'clock.

Among those who believed that slower travel would reap its reward in the final classification were the drivers of the Frayer-Miller and the Franklin, the only air-cooled candidates. It was almost 9 o'clock when the couple entered the garage together and set circulating stories of the journey having been covered on less than eight gallons of gasoline. The two small Maxwells followed the same slow and sure policy. The American Mors, a big, comfortable-looking limousine, which had carried its load of five in luxury and without a hitch, was one of the few high-powered cars to arrive after 9 o'clock. H. A. Martin accepted a heavy handicap when he undertook to drive a limousine in competition with light touring cars, but he certainly gave his passengers the most enjoyable trip of the day.

The first prize is a handsome imported bronze of an Indian girl on a marble pedestal, valued at \$200. Second prize consists of a well executed bronze of a lion and a lioness, valued at \$100, and the third prize, a sterling vase with heavy floral decorations, its value being \$50. About 60 per cent. of the entry fees were expended by the committee in prizes, the remaining 40 per cent. being for necessary expenses attached to the organization of the run.

The energetic contest committee, consisting of A. R. Pardington, chairman; C. G. Arnold, F. D. Bandell and Secretary Russell A. Field, was ably assisted by the following staff of officers: Referee, Jefferson DeMont Thompson; judges, F. G. Webb, Alfred Reeves, Dr. C. B. Parker; judges of gasoline, E. L. Ferguson, L. T. Weiss, A. C. Alderman; judges of lubricant, H. L. Towle, R. H. Johnston, A. F. Camacho; judges of observers, W. R. Lee, W. C. Colson; judges of passengers, A. W. Blanchard, R. G. Howell; timers, C. J. Dieges, V. Clust; starter, Fred Wagner; checkers, L. M. Bradley, M. C. Reeves, K. S. Arnold, J. E. Goey.

Particulars of the Twenty-three Competitors.

No.	Car.	H.P.	Entrant.	Driver.	Seats.	Wt.
1.	Pope-Hartford	30	A. G. Southworth	Phil Haynes	5	2500
2.	Hoi-Tan	25	Hol-Tan Co.	V. A. Nelsen	4	2400
3.	Lozier	45	H. D. Lozier	H. Michener	7	3400
4.	Franklin	16	Franklin Auto Co.	H. A. Vall	4	1600
5.	Haynes	30	W. E. Shuttleworth	Shuttleworth	4	2250
6.	Acme	45	J. W. Mears	J. W. Mears	7	3600
7.	Acme	45	J. W. Mears	Flinn	3	3200
8.	Acme	35	J. W. Mears	Walton	4	3300
9.	Cadillac	10	J. D. Rourk	J. D. Rourk	4	1650
10.	Pullman	20	F. Cimlottl	R. Morton	5	1900
11.	Mora	24	Mora Co.	W. Birdsall	3	2000
12.	Studebaker	30	Studebaker Co.	J. Holm	5	2550
14.	Pope-Hartford	30	J. W. Sutton	C. G. Arnold	5	2750
15.	Rambler	22	Homan & Schulz	D. C. Teetor	5	2600
16.	Am. Mors	40	St. Louis Co.	H. A. Martin	5	3100
17.	Maxwell	24	I. C. Kirkham	I. C. Kirkham	5	2100
18.	Maxwell	20	I. C. Kirkham	C. Hosley	5	1600
19.	Frayer-Miller	24	H. H. Knepper	H. H. Knepper	5	2200
20.	Lozier	45	D. Mahaney	D. Mahaney	7	3400
21.	Winton	50	C. A. Carlson	C. A. Carlson	7	3700
22.	Thomas Detroit	40	Brun Auto Co.	W. H. Bowers	5	2600
23.	Stevens-Duryea	35	F. Swan	K. Swan	5	2600
24.	Buick	22	Hugo C. Gibson	Hugo C. Gibson	5	1600

RENAULT TAXICAB SERVICE IN NEW YORK.

Paul Lacroix, general manager Renault Freres Selling Branch, New York City, announces that about March 10 he will take possession of the new six-story building, Nos. 214-216 West Sixty-fifth street, especially built for the sole use of the Renault garage, spare parts, and repair shops, and Renault taxicab department. The garage will be for the use of Renault owners exclusively. Mr. Lacroix states that it will be as complete in every detail as any of the Renault Paris garages and will be conducted on similar lines with the French workmen. New York is soon to have a Renault taxicab service.



ACME SCORES FOR FIRST LEG OF JOURNEY.



MORA REACHES THE LINE ON TIME.



STUDEBAKER: PILOT HAPPY, PASSENGERS FROZEN.



RAMBLER OCCUPANTS WEATHER-FORTIFIED.

## MANY PERFECT SCORES IN BAY STATE RUN

**B**OSTON, Feb. 22.—Twenty cars competed in the endurance run to-day of the Bay State Automobile Association, and of that number fourteen—ten touring cars and four runabouts—not only finished the road test with perfect scores, but successfully passed the examination of the technical

Stevens-Duryea No. 15, entered by the J. W. Bowman Company and driven by J. W. Robinson, was penalized eight points for four minutes spent near Providence in adjusting a fan belt. The Thomas Detroit, No. 3, entered and driven by J. S. Harrington, was penalized five points for stalling the motor at the start of the last stretch of the run. The Springfield, No. 4, entered by the Harry Fosdick Co. and driven by L. D. Robbins, had trouble with the steering gear, but was repaired and was able to return to Boston under its own power. The Knox, No. 8, entered by the Knox Automobile Company and driven by A. E. Dennison, was obliged to discontinue because of trouble with the rear axle, while the Winton, No. 9, entered by the Winton branch and driven by L. B. Harris, was delayed by a gasoline feed pipe which caused bother.

The weather and road conditions, considering the time of year, were excellent. Overhead the sun shone brightly all day long and there was just enough bite in the air to make a fur coat feel comfortable and not enough chill to prevent the observers and other passengers thoroughly enjoying the trip of about 135 miles

from Boston to Providence, Providence to Worcester and Worcester to Boston. The snow and ice left by the storm earlier in the week had made the highways rather rough, but they were much better than many of the drivers anticipated, and the rough ice was better than the soft snow and mud that prevailed earlier in the week. The contest committee, expecting bad road conditions, had made a slow schedule, but once the run was started it was found that the cars were having so easy time in keeping their schedules that the runs between controls beyond Providence were shortened considerably.



IT WAS EARLY IN THE MORN WHEN THE CARS STARTED FROM BOSTON.

committee without having any black marks scored against them. The perfect score cars were as follows:

- No. 1—Marmon, entered by F. E. Wing, driven by F. E. Wing.
- No. 2—Thomas-Detroit, entered by the Whitten-Gilmore Co., driven by Charles E. Whitten.
- No. 5—Studebaker, entered by Studebaker Automobile Co., Boston branch, driven by Walter Jones.
- No. 6—Atlas\*, entered by Harry Fosdick Co., driven by W. E. Ruggles.
- No. 7—Knox, entered by Reed-Underhill Co., driven by William Bourque.
- No. 10.—White, entered by the White Co., driven by H. K. Sheridan.
- No. 11—White, entered by The White Co., driven by Walter White.
- No. 12—Thomas Flyer, entered by J. S. Harrington, driven by A. H. Dorsey.
- No. 13—Reo\*, entered by Linscott Motor Co., driven by F. H. Pratt.
- No. 14—Austin\*, entered by I. N. Litchfield, driven by J. C. Kennedy.
- No. 16—Lozier, entered by H. C. & C. D. Castle, driven by Harry Michner.
- No. 17—Oldsmobile, entered by Algonquin Motor Car Co., driven by J. H. Hobson.
- No. 18—Rambler\*, entered by V. A. Charles, manager for Thos. B. Jeffery & Co., driven by E. W. Williams.
- No. 20—Franklin, entered by Franklin Automobile Co., driven by Theodore Young.

Of the six cars which failed to make perfect scores, three finished with penalties and three dropped out. Of those which finished, the Rambler touring car No. 18, entered by V. A. Charles and driven by him, was penalized four points for two minutes delay in adjusting a needle valve. The

\*Runabout.



AND IT WAS DUSK OF EVENING WHEN THEY WERE CHECKED IN

The lot of cars which left the clubhouse of the Bay State Automobile Association at one minute intervals after 7:01 A. M. was a most representative assortment, and the fact that fourteen successfully completed the run in good condition speaks much for the advance that has been made by the industry. A year or two ago the fact that a car was able to cover the triangle at all, to say nothing of keeping on a schedule and being subjected to a trying examination by a committee of technical experts, would have been recommendation enough. The entries represented almost every shade of opinion among automobile designers and manufacturers. Among them were air-cooled and water-cooled cars, two, four and six-cylinders, tourers and runabouts, two and four-cycle motors, vertical and V motors, small, medium and high-priced vehicles. And nearly every variety was represented among the perfect score machines, a fact which is commendatory to the American industry as a whole.

The drivers, too, represented varying shades of experience. There were Walter White and Hal Sheridan, veterans of many a tour and endurance run, one of them the winner of the Hower trophy in last year's A. A. A. tour.; F. E. Wing, who drove a Marmon air-cooled car with a perfect

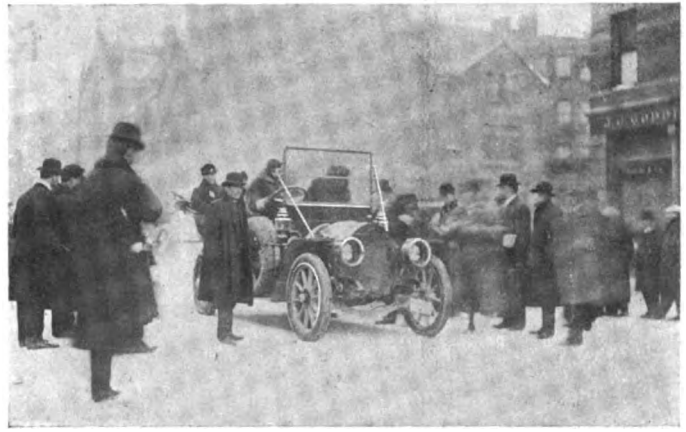

ONE PERFORMER WAS A "BIG SIX" THOMAS.

of the contest is in large part due to its efforts, as well as to the high quality of the cars entered and the skill of the drivers.

There were five controls in the course of the run. The first was at Walpole on the way to Providence, and the second in the city of Providence. A stop of forty minutes was allowed in Providence, and the Rhode Island Automobile Club extended every possible hospitality to the contestants and those who accompanied them. Between Providence and Worcester the first control was at Uxbridge, and the second at Worcester, and there the Worcester Automobile Club kept open house for the visitors during the short stop for luncheon. An unusual incident happened in Worcester and Arthur Knights, the confetti carrier, came near getting into trouble with the United States postal authorities. While he was passing through the city Postmaster Hunt noticed that the bags from which the confetti was being thrown were United States mail bags. He stopped Mr. Knights and warned him that he was committing an offense against the Federal laws in using mail bags for that purpose. Mr. Knights explained that the bags were given him by the party that provided the confetti. Postmaster Hunt advised him to leave the bags in Worcester, which he did, transferring the confetti to some potato sacks.

The only control between Worcester and Boston was at Wayside Inn, and from there the roads to Boston were excellent, and Mr. Wing with the leading car checked in exactly on time at 4 o'clock in the afternoon. As rapidly as the cars arrived they were taken into the White garage on Newbury street and placed at the disposal of the technical committee. Pending the report of the committee the competitors and the passengers, with the exception of Mrs. J. S. Harrington and Mrs. E. M. Dodge, the only women to make the run, awaited the final returns at the Bay State clubhouse.

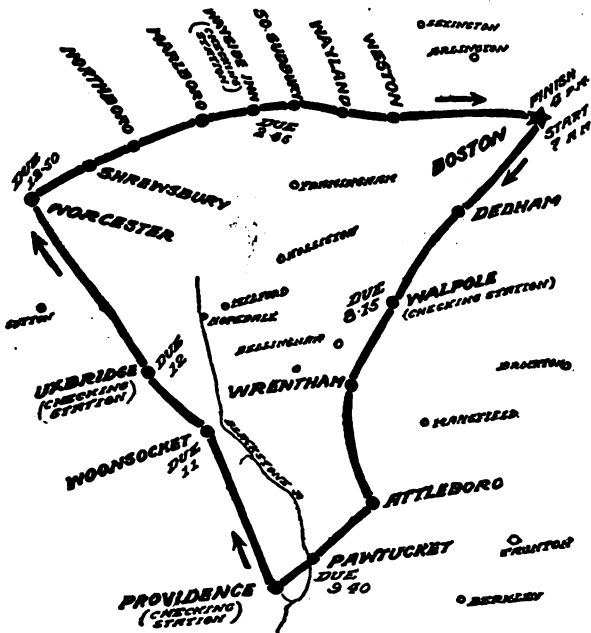

ROUTE OF THE BOSTON 135-MILE ENDURANCE RUN.

score in the Glidden tour in 1906; Fred Pratt, whose performance with the little Reo won him praise from his competitors equipped with much larger and more powerful machines; A. H. Dorsey, whose Thomas Flyer was the same that recently made the snow ploughing trip from Buffalo to Boston; and others of much less experience, who nevertheless handled their cars with equal skill. Every driver made each of the controls on time, the penalties being inflicted by observers.

The last car was sent away at 7:21 A. M. Ahead of the contestants Arthur Knights with his Oldsmobile scattered a trail of confetti and J. W. Maguire, with a six-cylinder Pierce Great Arrow, carried out the checkers. Behind the contestants Henry S. Johnson with a six-cylinder Premier, Manager Kilbourne with a six-cylinder Franklin, and A. E. Morrison's Wayne took care of the officials and newspaper men and picked up the checkers as soon as all the cars had passed their stations. The committee, consisting of John C. Kerrison, chairman; Ernest A. Gilmore, of the Whitten-Gilmore Company; Alfred N. Robbins, of the Harry Fosdick Company, and Col. Horace G. Kemp, did excellent work in preparing for the run and carrying it through, and the success



WALTER WHITE CHECKING IN AT PROVIDENCE.





**BAY STATERS: ROBBINS, KEMP, KERRISON, AND GILMORE.**

It was 9:30 o'clock in the evening when the technical committee made its report. It stated that after carefully examining all the cars it had been unable to find any cause for changing the results as shown by the road test. This was a most satisfactory finish for the contest, and, as a majority of the drivers and entrants of the perfect score cars opposed an attempt to run off the tie, it was decided not to hold another contest to break the tie and to award certificates to all the cars which had made perfect scores.

**DETROIT AGAIN HEARS MACHINERY'S MUSIC.**

DETROIT, Feb. 24.—There is music in the air, and it is not the distressing strains of a dirge either, so far as local automobile manufacturers are concerned. On every hand there are evidences of activity in anticipation of what the coming season will bring forth. A portion of this optimism is based on results at the show just closed, but makers are banking largely on conditions as revealed by a careful canvass of the trade in general.

Two months ago scarcely a wheel was turning in the local automobile factories. This was not wholly unexpected, for the early winter months are always quiet.

**YORK COMPANY ENTERTAINS PRESS MEN.**

YORK, PA., Feb. 26.—The York Motor Car Company, manufacturers of the Pullman automobile, entertained the sporting writers and automobile editors of the Philadelphia, Harrisburg and York newspapers at a banquet last night. Every newspaper in these cities was represented, and L. E. French, the Philadelphia agent for the company, acted as toastmaster. The owners of the plant were in attendance and responded to toasts, as did several of the "pencil pushers."



**CHECKING IN THE BUNCH OF CARS AT PROVIDENCE.**

**NEW YORK-PARIS MEN FIGHTING WITH SNOW.**

That endurance run to Paris, which everybody persists in calling a race, has descended to such a low rate of travel that whatever element of speed there may have been in it at the commencement has now been removed. When Montague Roberts, who has throughout maintained the lead on the Thomas car, reached Toledo at the end of the seventh day, it was supposed that he would be in Chicago 48 hours later. He made a splendid exhibition on the run to Kendalville in the face of a snowstorm, but since then has had a terrible struggle with Indiana snowdrifts. After four successive days in which the mileage was 17, 42, 24 and 11, Roberts hitched his car onto the Lake Shore tracks and ran into Chicago under his own power, arriving at the automobile clubhouse at 4:25 P. M. on Tuesday, February 25, having covered the first 1,043 miles in 13 days, 6 hours and 10 minutes. On Thursday he will leave for Ogden.

The De Dion, as the result of a broken driving shaft, fell behind the American car on the eighth day of the run and had not been able to make up the difference on the thirteenth day. For a time the Italian Zust was second in the trail, but by the time North Carlisle, Indiana, was reached the Frenchman had rejoined the Italian and was but five miles behind



**THOMAS SURMOUNTING THE INDIANA SNOWDRIFTS.**

the American. So heavy are the snowdrifts that a track cleared for the leading car is of no assistance to the others following a few hours later, every team being obliged to work constantly with shovels, horses and plows to clear a track through the deep snow. The slower German Protos and French Motobloc have closed up somewhat on the leaders, but unless weather conditions change quickly will again lose their advantage in the deep snowdrifts of Indiana. The mileage of the five cars from the seventh to the thirteenth day, inclusive, is as follows:

Car.	Nation.	6th day	7th day	8th day	9th day	10th day	11th day	12th day	13th day
Thomas	(American)	566	785	891	904	921	963	987	998
De Dion	(French)	566	756	888	895	895	895	921	963
Zust	(Italian)	543	667	854	881	895	912	949	963
Protos	(German)	471	566	613	617	725	817	865	888
Motobloc	(French)	352	471	548	613	693	785	854	881

**STUDEBAKER COURIER CAR REACHES CHICAGO.**

CHICAGO, Feb. 25.—The Studebaker car carrying the war message from New York City to Fort Leavenworth reached Chicago at 4:20 P. M. to-day shortly in advance of the first New York-Paris racer. Since leaving New York the car has been handled by three shifts of drivers, working eight hours on a stretch, and the intention is to make the journey in as short a time as possible under the adverse conditions now prevailing. The car is standing the journey exceptionally well. Its equipment includes anti-skid Continental tires.

## SIX NATIONS TO PARTICIPATE IN GRAND PRIX

PARIS, Feb. 15.—Thirty-seven powerful racers, carrying the colors of France, America, Germany, Italy, Belgium and England, are already officially engaged to compete in the French Grand Prix at Dieppe, July 7. Twenty-four hours remain in which further entries may be received at ordinary fees, and there is a possibility of half a dozen late comers handing over half a dozen thousand dollar fees before Secretary Sautin raises the rates. The feature of the entry list is the comparatively low French representation. Several

tice the changing of wheels is forbidden; this so angered Edge, who has used detachable wheels exclusively in his 1907 track racing, that he accuses his neighbors of unsportsmanlike practices and refuses to race on their terms.

Ten rounds of the 77-kilometer circuit will have to be covered by the Grand Prix racers and 6 rounds by the Voiturettes. This will give a total distance of 478.4 miles for the powerful cars and 287 for the small racers. As practically all the drivers have had some experience on the course, there has not

been the same wild rush to the Dieppe course that usually marks the selection of a circuit. Road tests of the actual cars to be used in the Grand Prix have already begun, the Renault team leaving for Dieppe this week and Gabriel and Rigal of the Bayard-Clément factory being already on the course. The ex-Dietrich driver has one of the 155-millimeter cars; his companion is piloting one of the fastest machines of last season, the object being to test the two side by side on the road. From the reports of the drivers the surface of the course is in excellent condition after the winter storms and will not call for much labor to put it into first-class racing trim. It is intended, however, to remake all weak spots and thoroughly retar.

As an instance of the thoroughness with which preparations are being made for the race, the Bayard firm has built two series of cars, one set with a stroke of 6.6 inches, the other with 7.2 inches stroke. Bore in each case is the maximum of 155 millimeters, all other structural features being identical. Unless the British Napier team is entered it is certain that all machines will be of the four-cylinder four-cycle type, and all with the exception of the American will have the maximum bore of 155 millimeters. As last year, the Panhard engines will probably be tried out on Monaco motor boats before being put on the racing chassis.

It would appear that no firm will take advantage of the

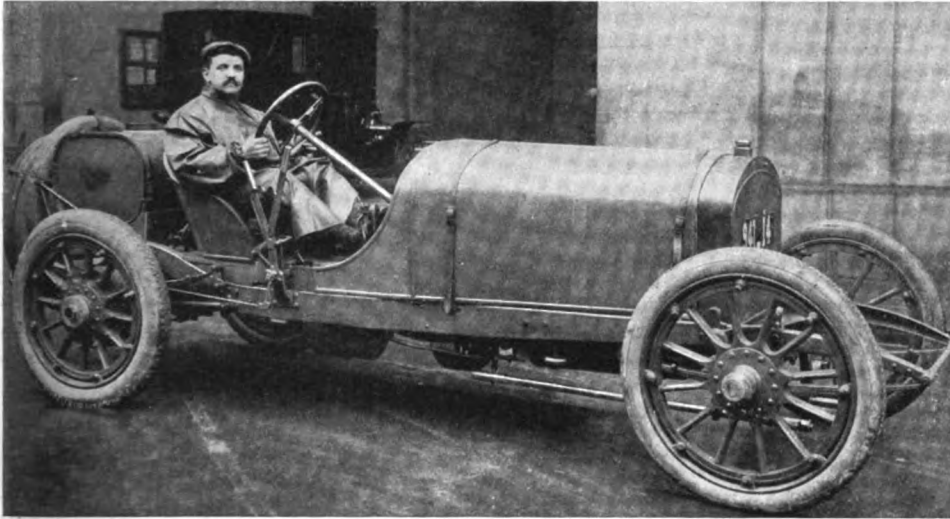

GABRIEL READY FOR ROAD TESTS ON BAYARD-CLEMENT RACER.

firms more or less consistent in speed contests in the past have restrained from racing this year. Darracq, hitherto irrepresible where records were at stake, will be a mere spectator on the Dieppe course. His abstention is declared to be due to the fact that the big factory on the banks of the Seine is now largely under British control, the directors from across the Channel not being as keen on building flyers as the man who sent Wagner over the Atlantic for the Vanderbilt Cup. It is an open secret that the withdrawal of Darracq cars from official participation in last year's races was due to British influence on the board of directors. Hotchkiss will not line up; Henri Brasier, though taking a keen interest in the race, is not certain to hand over the necessary fee allowing him to run three cars; Gobron, Mors, and C. G. V. are other large firms which will not be represented.

As the list stands at present, France has 15 cars against 22 for all other countries, individual figures being Germany 9, England 6, Italy 3, Belgium 3 and America 1. There are still hopes that S. F. Edge will come into line and increase the British representation by three Napiers. For weeks a wordy battle has been waged between the militant Englishman and the leaders of the French club on the use or non use of detachable wire wheels in the Grand Prix. Following previous prac-

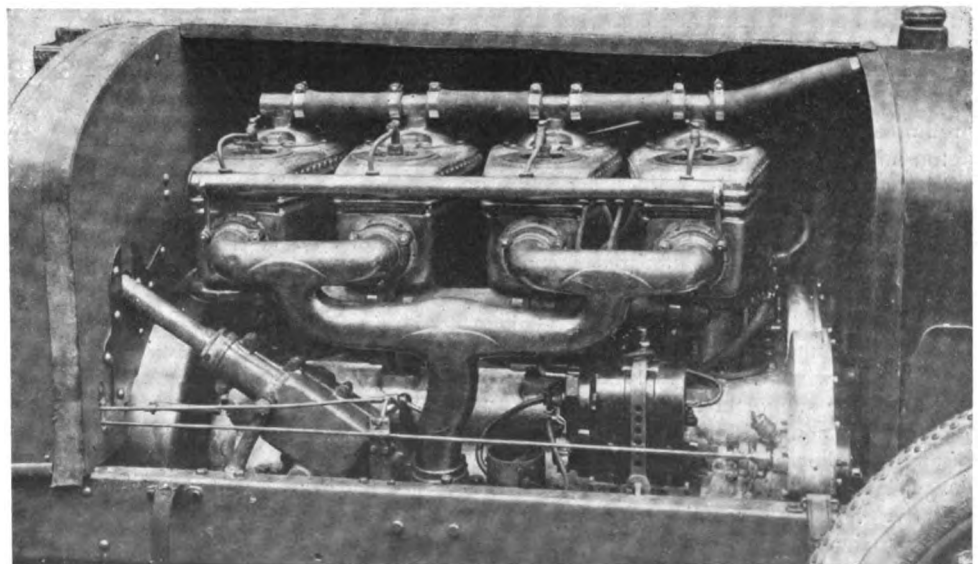

BAYARD-CLEMENT ENGINE PRODUCED UNDER NEW INTERNATIONAL RULE.

special opportunity to race two-cycle cars against those of the four-cycle type under the maximum bore rule. Those firms having studied the two-cycle engine seriously have failed to be moved by the offer of the Racing Board.

The full list of entries a few hours before the official closing is as follows:

Germain (Belgium), Desgrais.	Dietrich (France), Duray.
Germain (Belgium), Roch- Brault.	Dietrich (France), _____
Germain (Belgium), Perpère.	Dietrich (France), _____
Benz (Germany), Hemery.	Austin (England), _____
Benz (Germany), Hanriot.	Austin (England), _____
Benz (Germany), Earl.	Austin (England), _____
Fiat (Italy), Lancla.	Renault (France), Szisz.
Fiat (Italy), Nazzaro.	Renault (France), Caillols.
Fiat (Italy), Wagner.	Renault (France), Dimitriewitch.
Panhard (France), George Heath.	B a y a r d - C l e m e n t ( F r a n c e ) , Rigal.
Panhard (France), Maurice Farman.	B a y a r d - C l e m e n t ( F r a n c e ) , Gabriel.
Panhard (France), Classac.	B a y a r d - C l e m e n t ( F r a n c e ) , Hautvast.
Motobloc (France), Courtade.	Opel (Germany), Fritz Opel.
Motobloc (France), Pierron.	Opel (Germany), Joris.
Motobloc (France), Garcet.	Opel (Germany), Michel.
Mercedes (Germany), Willy Poege.	Weigel (England), _____
Mercedes (Germany), Salzer.	Weigel (England), _____
Mercedes (Germany), Lauten- schlager.	Weigel (England), _____
	Thomas (America), Montague Roberts.

#### Race of Little Fellows Day Before Grand Prix.

Being almost entirely confined to French cars, the Voiturette race to be run the day preceding the Grand Prix will not arouse much international enthusiasm, though home constructors are busily discussing the possibility of high speeds with the 3.9-bore single-cylinder racers. Twenty-four cars are now entered, all French with the exception of the Isotta-Fraschini team of diminutive four-cylinder racers. The Italian firm is also the only one to build four-cylinder cars under the Voiturette limited bore rule. A few of the French firms may put in two-cylinder cars, and one house at least will enter a two-cycle engine, but the large majority will present four-cycle, single-cylinder engines of 3.9 inches bore.

#### TAXICAB, ALCOHOL AND ENGINE TESTS.

PARIS, Feb. 17.—Taxicabs, motors running on alcohol, and high-powered engines are each to be provided by a public competition through the efforts of the Automobile Club of France. The taxicab event, to form a part of the industrial vehicle competition of the A. C. F. in May, will provide for engines of 3.9 bore for a single cylinder and a four-cylinder of 3.1 inches bore. Maximum weight, with passengers on board and tanks filled, is fixed at 2,200 pounds for the smaller cars, the proportion to increase with cylinder area. Maximum and minimum speeds are to be 9 and 18 miles an hour. After a preliminary endurance test the survivors will be classified on a ton-mile fuel consumption basis, denatured alcohol to be used exclusively.

In connection with the Anti-Alcoholic League, the A. C. F. technical committee will hold a power and consumption test for all types of motors using denatured alcohol. The competing engines must undergo a six-hours' test under full load, three hours under half load, and three hours running free. Lowest consumption and highest power developed will determine the winner. The teetotal league gives a \$400 prize and a private supporter another of \$1,000.

The third competition is for internal combustion engines of any type, horsepower to be not less than 24 nor more than 80. Weight of the engines must not exceed 8.8 pounds per effective horsepower, all accessories connected with the motor to be included. The average power developed under a three hours' test with full load will determine the winners. Engines must be run light 15 minutes before load test.

#### MOUNTAIN SPEED TRACK FOR FRENCH CLUB.

PARIS, Feb. 17.—A permanent course to be used for all races and touring contests in France has again been brought up for discussion by the departure of a delegate of the Automobile Club of France to study a track in mountainous Auvergne. As at present proposed, the scheme provides for the cutting of two parallel roads around the steep slopes of the Puy-du-Dome, over a part of which the Gordon Bennett race was run in 1905. The two ring roads, united at one point, give a total distance of 24 miles along the flank of the mountain. All the land in the neighborhood of the course is of a volcanic origin unsuited for cultivation. There are no cross roads whatever, and although a local railroad crosses the proposed course it will in no way interfere with the speed track, for the rails will be carried either over or under the road.

It is proposed to construct a double track of a total width of 78 feet, divided in the middle by a low barrier and fitted with central electric lamps at distances of 100 yards. Each track will be curved, have a gutter for carrying away the water at the inside and the outside and be protected by a high banking and a fence four feet in height. Grandstands erected within the course will be reached by the track railroad. It is estimated that the total cost of constructing the course will be \$400,000. This sum will include the electric lighting station, power for which will be obtained from a mountain stream. The land being of very low value, it is not supposed that there will be any difficulty in obtaining a right of way. Clermont-Ferrand, but eight miles distant, is the home of Michelin and other important tire manufacturers.

#### ECONOMIC SUGGESTIONS FOR PARIS SALON.

PARIS, Feb. 17.—If the Federation of Cycle and Automobile Manufacturers, of which M. Darracq is president, could have its way, there would be no Paris Salon this year, that body considering an exhibition every two years quite sufficient for the industry. As the Federation is only one of three bodies responsible for the holding of the show, and is in a minority on the period question, it will content itself with suggesting economic reforms. The Salon, it declares, should not continue more than ten or twelve days; the competition for decoration of stands should be abolished; fifty per cent. of the net profits should be distributed among the exhibitors in proportion to the amount paid for space; there should be no increase in the price for space. Finally, the date they consider most suitable for the show is the first fortnight in December. There is a consensus of opinion that a good show can be held without lavish expenditure of money.

#### ZEPPELIN AIRSHIP TO BE BOUGHT BY GERMANY.

BERLIN, Feb. 10.—At the recent meeting of the Budget Commission of the Imperial Diet, it was resolved to grant the demanded sum of 400,000 marks for aerial motor tests and to acquire the airships built by Count Zeppelin for the sum of 2,150,000 marks. Aerial motorism has found a great supporter in the German nation, as all parties were at one on the point of the desirability of furthering its progress to the utmost.

The Swiss Aero Club has resolved to enter two balloons for this year's Gordon Bennett of the air.

#### VICHY OFFERS \$4,000 FOR AERO PRIZES.

PARIS, Feb. 17.—Four thousand dollars are promised as cash prizes for an aeroplane competition that the Aero Club of France will organize at Vichy next September. The tests will be held, in all probability, on the Vichy racecourse. To cover the expense of transporting the flying machines to Vichy an allowance of \$200 will be made to every person taking part in the contest. Entries close July 15.

# PROBLEMS IN THE REPAIRING OF AUTOMOBILES\*

By THOS. J. PAY, E.E., PRES. SOCIETY OF AUTOMOBILE ENGINEERS.

THUS far, the vanadium chrome steel exposed to view presented a very nearly even chemical composition; that the composition is usually readily distinguishable without difficulty in the micro-photograph, will be seen by an inspection of the micro-photograph, Fig. 8, the data of which is as follows:

Magnification 350  
 Etching..... Deep  
 Condition.... Normal  
 Metalloids... Low  
 Carbon..... 16 points  
 Vanadium.... 0.16%  
 Chromium... 0.30%  
 Process..... Basic  
 Structure.... Characteristic

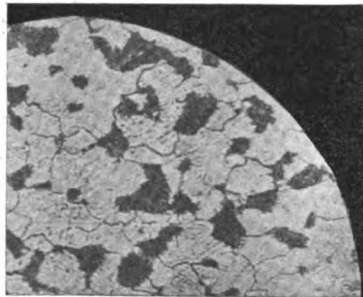

FIG. 8.

As will be observed, this specimen is one of very low chromium, and with a decreased vanadium content, with the further characteristic of low carbon. This is obviously a "cementing" (case-hardening) fabric. The effect of cementing on the product such as this will be found in Fig. 9 (core of the cemented section), the data of which is as follows:

Magnifications..... 350  
 Etching..... Deep  
 Condition..... Cemented  
 Metalloids..... Low  
 Carbon..... 16 points  
 Vanadium..... 0.12%  
 Chromium..... 0.30%  
 Process..... Basic  
 Structure..... Coarse

It might be well to show, by comparison, in so far as it will be possible to do so, the influence of these small increments of vanadium and chromium on the micro-structure, using for the comparison a micro-photograph of acid open-hearth steel. Fig. 10, which is an excellent exam-



FIG. 9.

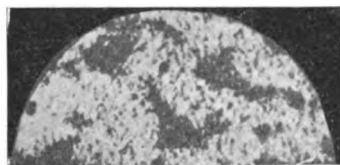

FIG. 10.

ple of the material in question, is offered with that end in view, the data of which is as follows:

Magnifications..... 350  
 Etching..... Deep  
 Condition..... Annealed at 800° C.  
 Metalloids..... Low  
 Carbon..... 25 points  
 Process..... Acid Open Hearth  
 Structure..... Characteristic

It would be possible to give many illustrations of the effect of vanadium in conjunction with chromium on steel, and to comment at some length upon the service to be expected. The scope of this article does not demand further effort in this direction, and it will be well to give to chrome nickel steel its measure of attention. That the chrome nickel steel looks better in the micro-photographs is to be expected, since the same steel tests better in practice. The extent of the improvement depending upon the care and the process in the fabrication of the steel. This is provided the ores used are of the desirable grades.

\*Continued from page 243, THE AUTOMOBILE, issue of February 20.

The first of these grades of steel to be taken up here will be one from a *special heat*, at the instance of the author, in which Wolfram was substituted for nickel. This steel is of excellent qualities, and the micro-photographs will show a considerably settled uniformity for this and the specimens (this is Fig. 11). Figs. 12, 13 and 14, each of them taken at high magnifications. The data of the chrome Wolfram steel, Fig. 11, is as follows: (Work done by Robert W. Hunt & Company.)

Magnification..... 1200 diam.  
 Objective..... 1/4"  
 Eye-piece..... 1"  
 Exposure..... 1/2 min.  
 Plate..... Cramer contrast  
 Light..... Electric Arc  
 Development..... Ferrous oxalate  
 Etching..... 40 sec.  
 Etching solution..... 10% HNO<sub>3</sub> in absolute alcohol  
 Iris diaphragm on microscope stopped down two-thirds.

CHEMICAL COMPOSITION

Chromium..... 1.44%	Silicon..... 0.0197%
Nickel..... None	Sulphur..... 0.033%
Wolfram..... 0.952%	Phosphorus..... 0.011%
Carbon..... 0.318%	Manganese..... 0.29%

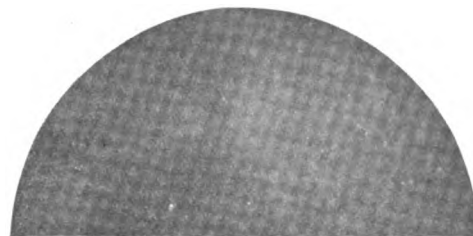

FIG. 11.

The micro-photographs, Figs. 12, 13 and 14, were made in substantially the same way, in the same laboratory; hence it will not be necessary to repeat all the details in the discussion thereof. Fig. 12 is of Krupp chrome nickel steel, the regular brand E. F. 60-0, the data of which is as follows:

Magnifications..... 1,200 diam.  
 Etching..... 50 sec. (light)  
 Condition..... Normal  
 Metalloids..... Low  
 Carbon..... 25 points  
 Chromium..... 1.69%  
 Nickel..... 4.40%  
 Process..... Acid  
 Structure..... Not defined

Fig. 13 is of "Bischoff" chrome nickel steel (soft), the data of which is as follows:

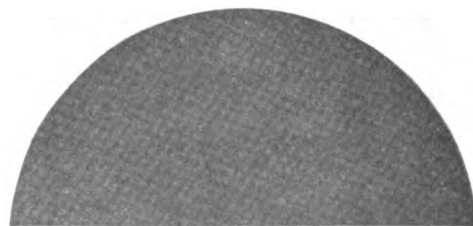

FIG. 12.

Magnifications..... 1,200 diam.  
 Etching..... 45 sec.  
 Condition..... Normal  
 Metalloids..... Low  
 Carbon..... 26 points  
 Chromium..... 1.10%  
 Nickel..... 3.69%  
 Process..... Crucible  
 Structure..... Not defined



Fig. 14 is of a fine American brand of chrome nickel steel, "Midvale," the data of which is as follows:

Magnifications.....	1,200 diam.
Etching.....	30 sec.
Condition.....	Normal
Metalloids.....	Low
Carbon.....	30 points
Chromium.....	1.23%
Nickel.....	3.60%
Process.....	Midvale
Structure.....	Not defined



FIG. 13.

Here we have, then, three standard grades of chrome nickel steel, all treated in the same way in the same laboratory, with the same skill, magnified to the same extent, and they look so much alike as to render the difference not apparent to the unskilled eye, to say the least. This is due primarily to the fact that the several products are very much alike, and again to the high magnification. With a view to showing that the detail can be brought out, Fig. 15, of Bischoff chrome nickel steel, is offered, the data being as follows for this case:

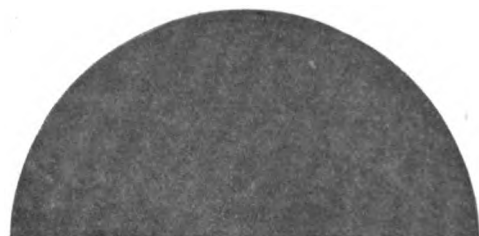

FIG. 14.

Magnifications.....	350 diam.
Etching.....	Medium
Condition.....	Cemented
Metalloids.....	Low
Carbon, Chromium and Nickel.....	Same as Fig. 13
Process.....	Crucible
Structure.....	Clearly defined

This micro-photograph clearly shows the depth of the hard "case," the soft "core," and the *intervening strata*. This is ample evidence of the fact that it is not desirable to go to high magnifi-

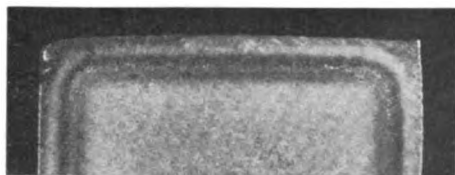

FIG. 15.

cations at all. This specimen is also indicative of definite data of the depth to which the hard case can be made to penetrate, if the cementing process is skillfully conducted.

Let us go into this matter at some further length, however, that we may know just what is the nature of the "shell" and the "sap" (core). To do this is to examine the micro-photographs of the same (each of them) in detail. For the "shell," Fig. 16 is here given, the data of which is as follows:

Magnifications.....	350 diam.
Etching.....	Medium
Condition.....	Shell (hard)
Metalloids.....	Low
Carbon, Chromium and Nickel.....	Same as Fig. 13
Process.....	Crucible
Structure.....	Well defined

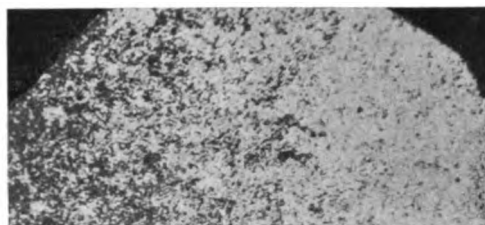

FIG. 16.

For the "core," as depicted, Fig. 17, the data is as follows:

Magnifications.....	350
Etching.....	Medium
Condition.....	Core (soft)
Metalloids.....	Low
Carbon, Chromium and Nickel.....	Same as Fig. 13
Process.....	Crucible
Structure.....	Well defined

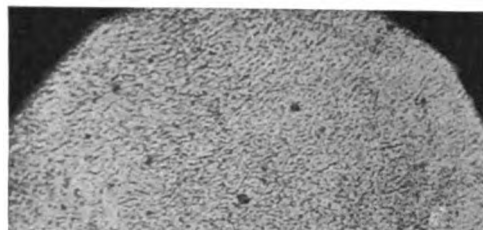

FIG. 17.

high magnifications; the Fig. 18 shows a fracture of a specimen of nickel steel at 20 diameters. It is obvious that if the micro-photographs can be distinguished from each other, the difference will be apparent to the observer through a microscope, or even if a magnifying glass is used of a power of 20 diameters.

That a repair man should be able to tell the genera of steel in a part is fairly certain; but should he fail to come that close,

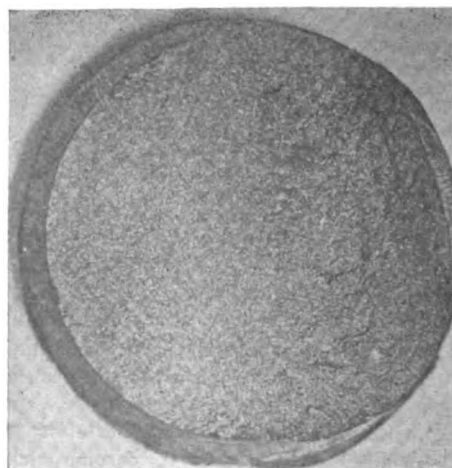

FIG. 18.

he can at least note if the structure is open or close, and the fracture can be inspected to observe if the same is *crystalline* or of a *silky* nature.

A little skill helps out wonderfully, and skill is but the prod-

uct of oft-repeated attempts. There are none with a monopoly of brains, though steel mongers are wont to have us think so.

At all events, it must be true that the quality of the material in the part to be replaced should be inferior, if anything, to the quality of the material of the replacement. This can only happen if the process of arriving at the conclusion is thorough.

#### Some Further Considerations in Conclusion.

In working up material for use in parts there are diverse ways of fashioning the parts, but it can be said the end will always be the same. In other words, the strength of the material may be adequate, but in the process the methods may be adverse.

Take, for illustration, the matter of crankshafts; if they are slabbed out, the result may be about the same as if a plank of wood were worked in the same way. The grain will lay so as to render the strength dependent upon the relation of the grain to the cuts, and the minimum strength is likely to be the result.

Broken crankshafts frequently show the effect of the manner in which they are made, in that they part in a plane parallel to the axis, through a crank arm, generally the one nearest the flywheel. If the crankshafts are from die (drop) forgings, this danger is not so imminent, because the grain lies in such a way as to afford the maximum strength.

If a crankshaft fails in service it is easy to lay it on to something besides the material or the manner of its fabrication, but as a rule the one or the other will be at fault. To simply duplicate the first error is but slight justice to the owner.

Take the question of changes in the contour of parts, the

changes should be anything but abrupt. Most ungainly looking fillets of considerable radii would be much more to the point.

A great many members fail through the section in the plane of threads; this is due to the fact that the roots of the threads are V-shaped and as a rule too deep. The Sellers thread is considerably better, besides the thread should not go clean up to a shoulder. Undercut for a distance of at least a full thread and end with a fillet.

A hole through a shaft close to a shoulder will help to concentrate the strains and the end may be the shaft will twist off at that point. There are crankshafts in cars that have this fault and they have repeatedly failed on that account.

The pinion of a planetary gear must be made with a small number of teeth and the shaft cannot be of great diameter; the pinion should not go up to a shoulder with no fillet; the shaft will twist off at the shoulder, even if there is a chance of it not doing so, assuming a radius. The material should be extra good for a case of this sort.

Keys will not hold unless they are fitted very tight. Put a boy on some other job, but put a machinist of considerable experience on the key fitting. A loose flywheel is not a pleasant thing to be ship-mates with in a swamp, miles from home.

When rear wheels come off, it is not safe to figure that the thing will happen in front of a hospital. They will come off if the fitting is not carefully done. As some cars are made, true, they may come off if the fitting is well done in certain cases. It is important to be very careful in such cases, and it will reflect no credit on the repair man who fails to do good work.

## MOTORS THAT HAVE MANY DISTINGUISHING FEATURES

It does not require more than a single glance to note that the motor shown by the accompanying illustration differs from automobile motors of its kind at present on the market. A closer inspection shows the view to have been taken from the inlet side of the engine, as will be evident from the attachment of the carbureter on that side, but the familiar maze of piping in the shape of manifolds that render access to the valve mechanism and other parts of the motor difficult, is entirely lacking. It will also be noticed that the ignition timer is placed directly alongside the carbureter, thus centering the parts most in need of inspection and adjustment at one point on the motor, and one that is entirely free from obstructions. Another striking feature of this motor is its lack of circulating water piping, as the only evidence of the latter is to be seen in the return pipe to the radiator, which runs along the top of the cylinders.

This great simplification has been accomplished by casting the individual cylinders with integral ports leading from the base up to the inlet valve openings. These ports in the cylinder castings correspond with similar openings cast in the upper half of the crankcase, or engine base. Both the gas manifold and the water-circulating pipes are cast on the inside of this base, thus making an extremely neat and simple motor, this location of the intake manifold also hav-

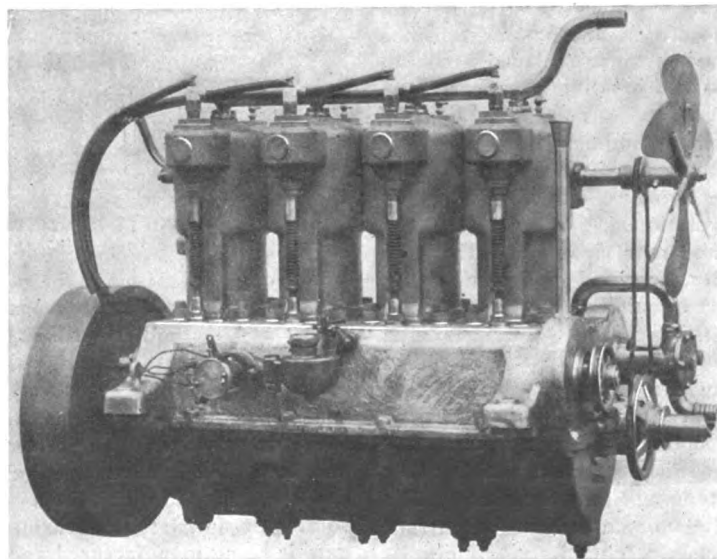

SIMPLICITY OF THE PIGGINS MOTOR, INTAKE SIDE.

ing the great advantage of warming the mixture. All connections are made at once, merely by fastening the cylinder in place on the base. Five liberal-sized main bearings are provided for the crankshaft, and they are automatically oiled by means of oil tubes and wicks, in addition to the usual standard splash system. The water pump, of the gear type, is located forward on the exhaust side and connects directly through a short pipe to the cast piping inside the crankcase. A petcock placed on the latter permits of entirely draining the entire circulating system at any time. This crankcase is so cast that the camshafts, complete with their gears, may be withdrawn without disturbing any other part. The connecting rods are steel drop-forgings with bronze upper bearings and babbitted big ends. The flywheel end of shaft is provided with a thrust ball bearing. This motor is but one of the many types made by Piggins Brothers, Racine, Wis., who have had a long and interesting experience in motor building, having constructed a steamer as far back as 1883, an electric in 1897, and their first gasoline car in 1902, the latter being a two-cylinder four-cycle 4 by 4-1/2 inch engine, capable of making 18 miles an hour with four up. Their present line includes two, four and six-cylinder vertical motors from 4 by 4 1-2 inches up to 6 by 6 inches, and a special line of vertical two-cycle marine motors.

### NEW TYPE OF INDUCTOR MAGNETO.

Leon J. Le Pontois, who has made an extended study of the problem of automobile ignition for several years past, has just completed a new magneto of the inductor alternator type, in which the rotor consists of a crescent-shaped iron core carrying no windings. It is an extremely simple and efficient generator and differs in numerous respects from the magnetos now in use.

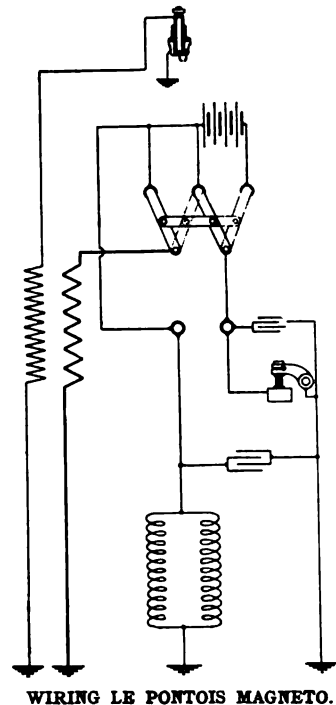

WIRING LE PONTOIS MAGNETO.

The field magnets and the windings in which the alternating currents are generated by the rotation of the iron core are stationary, no brushes or current collectors being employed. The magnetic field is composed of a number of steel plates pressed into close contact by the frame and securely held by bolts.

Each of the plates, or laminations, is magnetized by a special process which tends to cause the steel molecules to assume permanently parallel positions in the axis of magnetic polarization in the V-shaped portions of the field magnets. In order to obtain this result, the V-shaped ends of the plates are first brought to the desired temperature and then suddenly cooled and thereby hardened, while their

molecules are under the influence of a powerful magnetic field. The central portions of the plates, upon which the coils are wound, as well as the polar projections, are maintained thoroughly annealed during the process of hardening, the plates thus retaining their magnetism much better than when magnetized cold.

The V-shaped portions constitute the permanently magnetized portion of the magnetic structure. By thus providing the integral magnetic structure, which is hardened and permanently magnetized in certain portions, while it has soft portions of high magnetic permeability, it becomes possible to construct an inductor magneto having a good electric efficiency and a comparatively large output for its size. The extensions of one central portion are, therefore, say, of north polarity, while the extensions of the opposite central portion are of the opposite, or south polarity. The polar extensions around which the generating windings are placed are connected, as will be plain from the sectional view.

The rotation of the iron inductor causes the magnetic flux threading through the stationary windings wound on the bridges to pass from a maximum density in one direction to a maximum density in the opposite direction during a comparatively small angle of rotation.

The illustration shows face and rear views respectively of the circuit closer and interrupter, operated by a cam on the rotor shaft and serving to short circuit the combined circuit of the two stationary windings, excepting at or near the time when the current is employed to produce a spark. The means for closing and opening the circuit at the contacts comprise an arm pivoted to a part supported by the outside element of the machine. The shaft of the arm is oscillated by the engagement of a roller with the cam, which roller is carried by an arm, also extending from the shaft. The electric circuit is opened at the moment when the current induced in the stationary windings reaches its maximum.

The breaker is of an extremely simple construction and

can be removed from the magneto frame at any time for inspection should the platinum contacts require cleaning or adjusting. Two pointers respectively located on the breaking arm and its frame permit accurate adjustment of the breaker point, and when the frame is placed back in its casing, in the magneto frame, the timing is perfect. The frame and magnets are mounted in bearings so as to be adjustable therein. By reason of the exterior form of the plates and of the magnetic field composed of them, it is possible to swing the whole structure (field magnet and the breaker) about their pivotal supports without causing the magnets to extend laterally beyond the center diameter, thereby permitting an effective spark range of about 80 degrees without increasing the space occupied by the magneto. It will be noted that the spark has the same intensity in any of the positions in which it is necessary to shift the magnetic structure in order to vary the time of ignition.

It will also be noted that the dimensions of the polar faces of the rotating element in operative magnetic relation with the polar faces of the stationary element are such that the total magnetic reluctance of the combined magnetic circuits changes very little in the different positions of the inductor when rotating within the stationary structure. This is due to the width of the polar faces of the rotor being greater than the distance between adjoining polar extensions of the stationary element. Abnormal magnetic leakage which would otherwise lead to ultimate demagnetization of the permanently magnetized portions is consequently avoided. This arrangement also greatly increases the rapidity with which the intensity and direction of the flux in the generating windings changes, and correspondingly increases the intensity of the current generated. Thus, it will be understood that although the change in the density of the magnetic flux through the alternative paths successively controlled by the rotor tends to correspond with the respective reluctance of said paths, yet by reason of the fact that the windings are short circuited upon themselves while the reluctance of the magnetic path is increasing, the current induced in the coils tends to oppose such change, and the rate at which the density of the flux decreases is not proportional to the increase in reluctance of the magnetic path.

It will be noted that owing to their position in the field structure and their mode of connection, the windings exert a preponderating magnetizing action on the field structure,

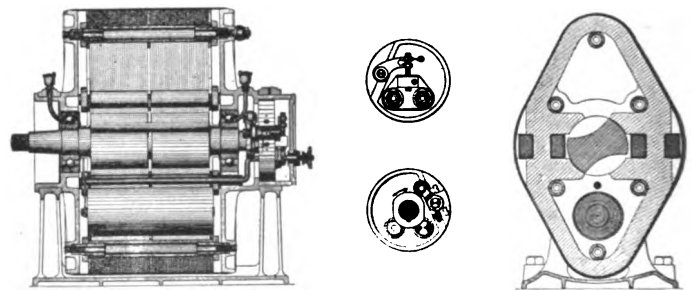

LONGITUDINAL AND CROSS-SECTIONAL ELEVATIONS AND BREAKER.

which tends to maintain the permanently magnetized portion of the field thoroughly magnetized. The wiring diagram shows the method of utilizing the breaker of the magneto in connection with batteries should it be desired to provide for double ignition. However, in actual service, it has been found that the electric output of the magneto is so great that the motor can be started by the crank without great exertion. The condenser is located within the magneto itself, but the induction coil is a separate unit. The armature rotates on annular ball bearings. The new Le Pontois magneto is being manufactured and marketed by Hurd & Haggin, 316 Hudson street, New York.

# SELF-ALIGNING TAPER ROLLER BEARINGS\*

BY H. W. ALDEN, MEMBER OF SOCIETY OF AUTOMOBILE ENGINEERS.

THE object of this paper is to present some facts concerning the design and action of certain forms of roller bearings and to illustrate their practical application to various automobile conditions.

I will touch on just four phases of the question that arise in automobile practice, viz.:

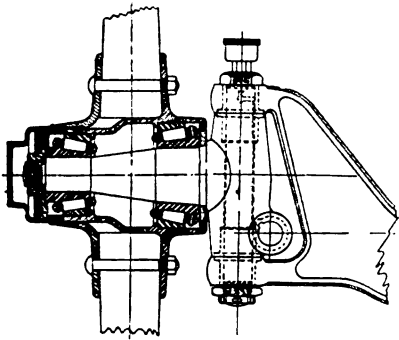

FRONT HUB, E. R. THOMAS MOTOR CO.

- (a) Side load capacity.
- (b) End thrust capacity.
- (c) Means for insuring correct alignment of rolls.
- (d) Provision for taking up wear.

There would seem to be no chance for argument that in the abstract a roll should be capable of carrying a greater load than a

ball of the same external physical dimensions, granting that material and workmanship are identical and eliminating the question of alignment of the roll. Comparisons made in this article will assume a ball bearing using a curved surface for the cone with a radius of .7 the ball diameter. No distinction will be made between the annular or radial, and the so-called bicycle type of ball bearing. In the roller bearing the diameter will be assumed, same as that of the ball with length equal to diameter.

If we consider that, when a ball or roller is loaded, there is an infinitesimal flattening out at the point of contact, then the load-carrying capacity, other things being equal, will be approximately proportional to the area presented to carry the load. We find that assuming the roll or ball and the cone to suffer a deformation of approximately one thousandth of the radius of the ball or roll, we get resulting areas in the ratio of approximately 7 1-2 to 1 for the roll and ball respectively. Now it is this remarkable showing that has tempted so many to experiment with the roller bearing. A search through the patent files of this country alone shows an almost unlimited number of attempts, very few, however, of which have ever come to light, and almost all of which have disappeared from view. Perhaps the majority of experimenters have tried the taper roll, which statement brings us to second point, end thrust.

The cases where a bearing is submitted to side load alone are possibly in the majority, but there are many cases where the bearing has both side and end load to withstand. This is particularly true in the case of the automobile, where perhaps the majority of the bearings have to stand thrusts, some of which, as in the case of wheels and bevel gears, are exceedingly severe. I think

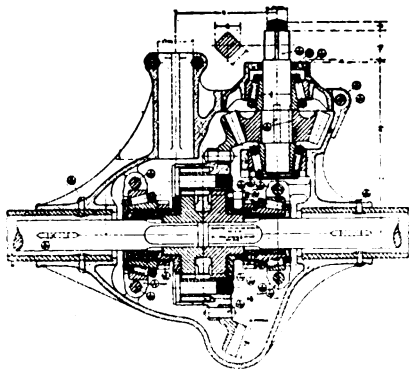

FORTY-H. P. REAR AXLE ASSEMBLY.

we sometimes fail to recognize the severity of this front wheel end thrust. When turning a corner of 25 ft. radius at 15 m. p. h., which is by no means rarely done, the end thrust on that front wheel bearing which gets the maximum thrust is just about the same as its legitimate side load. This bearing then ought, by virtue of its design, to be able to take about the same load one way as the other. Now this is a strong point of the taper roller bearing. It can be shown that such a bearing, having an included angle of approximately 23 degrees for the cup, can carry the same end thrust load as side load for a given surface pressure normal to the roll surface. I find that there is a pretty general impression that, in the case of a taper roller bearing, having an abutting shoulder, all of the end thrust load is taken on this small shoulder. This is not the case, as can be shown by a simple illustration. Suppose a complete bearing to be subject to end thrust, but not to be in motion. Now, while the load is still applied, remove the rib or shoulder on the cone, by screwing it back out of the way, for instance, and it will be found that nothing happens. No matter what the load, the rolls refuse to change position. Now rotate the bearing slightly and it will be found that, so long as the rolls remain in correct alignment, there is no

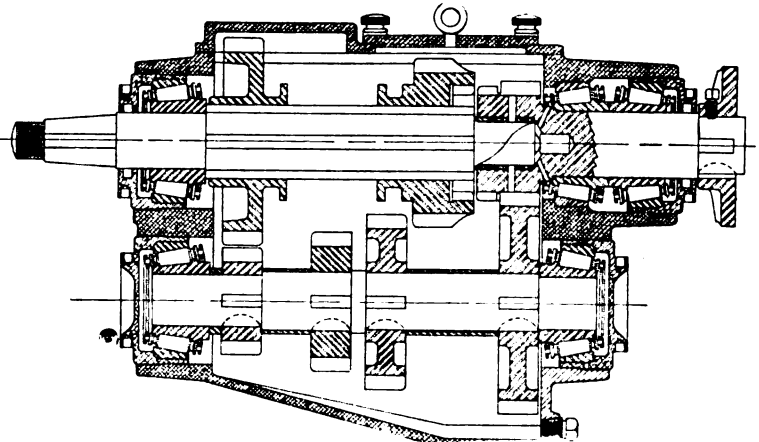

CHANGE GEAR SET MADE BY WARNER GEAR COMPANY.

axial change in their location. When they get out of alignment, however, they begin to creep back up the cone.

This brings us up to the third point in question, that of alignment. And this, be it said, is the feature of greatest importance in all roller-bearings. It is the rock on which many a roller-bearing has gone down. In the case of parallel roller-bearings, there is a peculiar but persistent tendency of the rollers to work endwise; not great, but still present. Now most parallel roller-bearings have some member either on the cone or cup, or both, to limit this action, and sooner or later the roll brings up against this abutment. So also in every taper roller-bearing, the rolls bring up with a certain slight pressure against this same limiting element. It is at this crucial point that roller-bearing designs and construction diverge. From this point all can be divided into two classes, those receiving this limiting effect at one end of the roll and those receiving it at both ends. Perhaps I should not have referred to the latter class in the plural, as there is only one where this effect is obtained, i. e., receiving this limiting action at both ends of the roll. If the roll bears ever so lightly against an abutting shoulder at one end only, the tendency is to exert a slight retarding effect at this point which disturbs the alignment. With the correct alignment

\*Paper read before the Society of Automobile Engineers at New York.



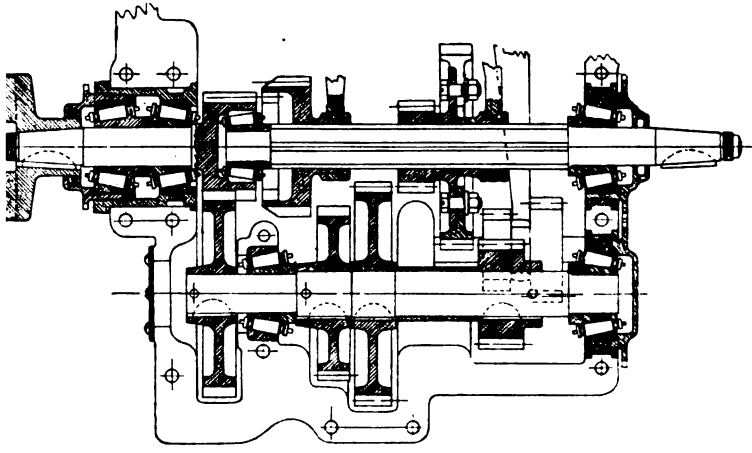

TYPE OF GEAR SET THAT IS USED ON THE AUTOCAR.

gone, there is then not pure rolling action, but a rubbing action, and furthermore the area of contact at once is greatly reduced. In other words, sliding friction has been substituted for rolling friction, and the contact area to carry the load has been reduced. The life of the bearing is therefore greatly reduced. When, however, this slight retarding effect is applied equally to each end of the roll, it is changed from a disturbing action to an actual guiding action.

When the Timken Company first began work on taper rolls, they, like all others before them and some since, had but one rib on the cone, and their earlier experiments were all failures, as could have been predicted had the proverbial foresight been as good as "hindsight." Upon the introduction, however, of the two ribs, the alignment difficulty disappeared, and some seven years' experience covering many forms of application prove the fundamental value of these two ribs. Another feature of the taper roller-bearing which appealed at the outset was the ability to take up wear with this form of bearing. We like to think that wear does not occur with pure rolling contact, but the bulk of the experience of users of bearings shows that in most cases wear does occur. If it cannot be taken up, it continues at an increasingly rapid rate, whereas, if it can be taken up, the bearing is ready to start out fresh again. Doubtless for some service, size and material can be chosen to eliminate wear from practical consideration. These cases are limited, however, and even in such cases a larger amount of material must be used than would be required if some wear could be tolerated. On the whole, then, from a practical standpoint, the taper roller-bearing using two ribs has good reason for its existence, because of its area of contact giving large side load capacity; its large inherent and thrust capacity; its insurance of correct roll alignment, and its adjustability for wear.

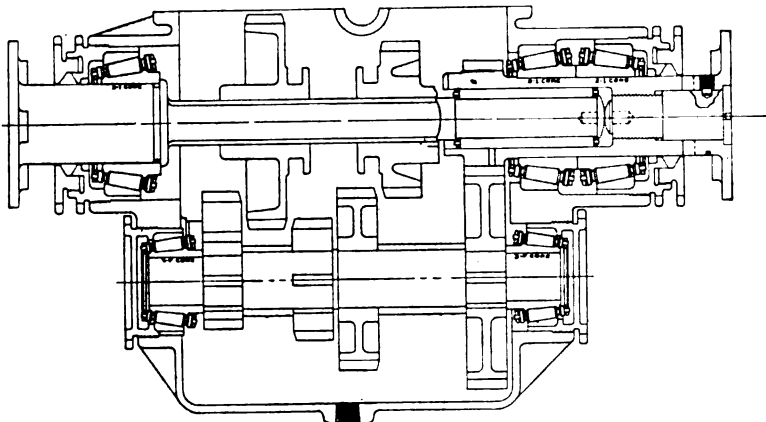

CHANGE-SPEED GEAR OF THE STODDARD-DAYTON.

### USING OXYGEN TO INCREASE MOTOR POWER.\*

It seems difficult to realize that the practice of "doping" may be extended from the race course to the automobile track, or *du sport hippique au sport mécanique*, as our Gallic confrères put it, but this is nevertheless the case, "drugged" motors having been used at Brooklands. But the drug in this case is simply oxygen, and the following is an elementary explanation of the phenomenon. It is a matter of common knowledge that the energy created by the four-cycle motor comes from the expansion of gas, raised by rapid combustion to a high temperature and pressure. These two values, temperature and pressure, are connected by a direct relation, the pressure on the piston, which is transformed into mechanical work, being greater as the temperature is higher. This relation permits of calculating the value of "doping" a motor.

Why this temperature should be so high is also easily explained. It is conceded that the explosion is an adiabatic combustion under constant volume. The heat produced by the combustion being employed to raise the temperature of the resulting gases, if we know the specific heat of these gases under constant volume, it will be easy to value the temperature theoretically attained. In the case of oxygen the weight of the gas to be warmed is less than that of air, since the latter is constituted, in weight, of 79 per cent. of an inert

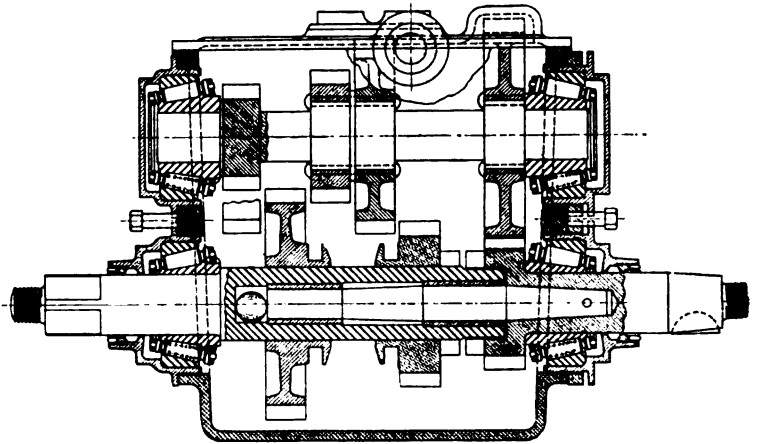

GEAR SET OF THE THOMAS DETROIT "FORTY."

gas, nitrogen, which does not participate in the reaction, but which must, nevertheless, be raised to the high temperature.

For an equal quantity of heat disengaged, the weight of the gas to be warmed, in the case of air, is greater as the temperature to be attained is lower, and it is calculated that the theoretical temperature attained by a gasoline flame in pure oxygen is 7,000 C., while it does not surpass 2,500 degrees C. in air. From this the enormous influence on the thermodynamic output of the motor which may be gained by the use of oxygen is evident. It must be borne in mind that there can be no question of supplying pure oxygen to a motor constructed according to present standards, as the explosive pressure reached would be such as to utterly destroy the cylinder. It is also necessary to radically change the conditions of carburetion, the amount of air necessary for complete combustion of a given weight of gas being diminished as the proportion of oxygen is augmented. It will be seen that this artificial enrichment of the mixture may be of considerable utility in certain cases, such as aviation.

The results already attained by M. Jaubert with an Aster motor, using "oxylithe," an alkaline peroxide producing oxygen in the presence of water, which is an invention of his, show that the injection of three liters of oxygen per horse-pirated, gives an increase in power of 70 per cent. power-minute, or 4 to 5 per cent. of the total volume as-

\*Translated from "La Vie Automobile," Paris, by Charles B. Hayward.

## LETTERS INTERESTING AND INSTRUCTIVE

### A METHOD OF OILING THE MAIN BEARINGS.

Editor THE AUTOMOBILE:

[1,188.]—Will you kindly tell me if you think this system of oiling the main bearings of a motor would be efficient? Enclosed is a rough sketch. The crank dips into the oil in the crankcase and some is forced into the hole at A. The passageway B becomes filled by the repetition of this and gradually the oil is forced out at C and lubricates the bearing. Do you think the centrifugal force would throw the oil out and so prevent it from reaching C? The other parts of the motor are to be oiled by the splash system.

Will you also give me the dimensions of standard auto frames? That is, the width at the front between the side members and the same for the back.

New York.

It is customary with quite a few American makers to drill the crankshaft in order to facilitate lubrication, and centrifugal force is taken advantage of to carry surplus oil fed directly to the main bearings, through holes to the crankpins. In the arrangement you outline there is nothing to prevent centrifugal force throwing the oil out of the hole faster than it can be forced in; in fact, it is doubtful if centrifugal action would permit any oil to reach the bearings through these holes. You are trying to force oil from a point on the

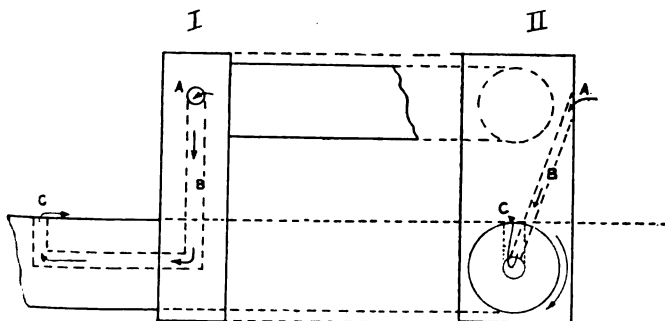

DETAILS OF THE PROPOSED LUBRICATING SYSTEM.

circumference of a circle to its center against the action of centrifugal force, which is constant, so that it will be plain that such an arrangement would not be practical.

Frame dimensions differ so much with different makers that it would be difficult to say whether there is such a thing as a standard for this essential. On touring cars the frame is narrowed forward to about 36 inches, in some cases slightly less and in others not so much. The width back of the motor is anywhere from 40 inches upward, but will probably not be found to exceed 48 to 50 inches in any case, as few cars exceed the standard tread, which is 56 inches. In a few instances the frame is not narrowed forward at all, in which case it will seldom be found to exceed 38 inches in width. This would probably only be found on what are known as light touring cars; also low-powered runabouts.

### KEROSENE AS A NON-FREEZING SOLUTION.

Editor THE AUTOMOBILE:

[1,189.]—Would you kindly state in your "Letters Interesting and Instructive" if kerosene is a good non-freezing solution to be used in cooling an engine? Would kerosene in any way affect the steel or working of the engine? If it does not, what per cent. should be used for Chicago weather?

Chicago, Ill.

If you will refer to letter No. 1078, from F. R. Zeigler, and the answer thereto, which appeared in the issue of THE AUTOMOBILE of January 9, 1908; also letter, No. 1129, from Cecil Carr, published in the issue of January 23, 1908, we think you will find the subject pretty well covered. Kerosene would have no bad effect on the metal of the engine and it would have to be used "straight" for Chicago, or any other brand of weather.

### RECORD-BREAKERS IN VARIOUS SPEED TESTS.

Editor THE AUTOMOBILE:

[1,190.]—Please let me know through "Letters Interesting and Instructive" the following facts:

(a) The date and time of the Stanley steamer one-mile record.  
(b) The date and time of the winners of the Fort George hill climb.  
(c) The date and time of the 1,000-mile record.

New Rochelle, N. Y.

CORNELIUS SHIELDS.

The Stanley steamer one-mile record was made on the Ormond-Daytona beach, January 25, 1906, Fred Marriott driving. Time, 0:28 1-5. Frank Leyland, driving a Stearns six-cylinder car, made the best time in the Fort George hill climb, August 3, 1907; time, 28 1-5. Time made by other winners was as follows: Class 100 to 125 square inches, C. P. E. Schilpp, on 60-horsepower Stearns, 32 2-5; class 80 to 100 square inch, P. J. Robinson, on 35-horsepower Stevens-Duryea, 36 1-5; class 60 to 80 square inch, J. P. Grady, 30-horsepower Pope-Hartford, 39 3-5; special for Stearns cars, W. A. Tilt, 44 4-5; electric, H. E. Wagner, on Babcock, 1:53 4-5. The world's 1,000-mile record was created by S. F. Edge in his 24-hour run on Brooklands track, England, June 28-29, 1907. No time was taken for the thousandth mile, but at the end of the fifteenth hour the distance covered was 1,006 miles 1,640 yards. The American 1,000-mile record belongs to Clemens and Merz, time, 21:58 4-5, on a 30-horsepower National, at Indianapolis, November 17, 1905.

### TAKES A NEW MAN TO CRANK IT EVERY TIME.

Editor THE AUTOMOBILE:

[1,191.]—I have a car which is giving me endless trouble. It wears a negro out each time it is cranked, and when once it decides to start the engine apparently runs all right until the low speed is thrown in, when she begins to stop, and when the high speed is thrown in, stops completely. The engine has just been overhauled, has good compression, and turns easily when the spark plugs are removed. The carbureter is located ahead of the cylinder and at about the same level, and uses cold air. Have tried two Kingston and one Schebler carbureters, one-inch size. Would it help materially to hang this carbureter under the engine, or by its side (which would cut off about 1 1-2 feet of pipe and one bend), and take hot air from off the exhaust pipe? Do you think a 1-inch carbureter large enough for this 20-horsepower engine? On account of the carbureter being on a level with the engine cylinder, does this allow too much gasoline to get in and make too rich a mixture? I notice in most engines the carbureter is below the cylinder inlet. Can you make me any suggestions?

Birmingham, Ala.

S. B. SLATER.

Judging from your statement of the case, it would seem that the trouble might be due entirely to deranged timing either of the valves or ignition; that is, the ignition timer has become so placed that while it will run the engine, the spark occurs in such a period in the stroke that there is barely enough power developed to turn the engine over light. The moment that any considerable load is applied, it naturally comes to a stop. This also accounts for the great difficulty you mention in starting, as it is next to impossible for any one cylinder to generate enough power to turn the engine over so that it will take up its cycle. Look to the ignition timer and set it with relation to the piston of the first cylinder, so that the spark occurs—the advance lever on the wheel being about one-third way down the sector—when this piston is at the upper dead center and about to descend on a power stroke. To find this out, the spark plug should be removed and a stiff piece of wire dropped into the first cylinder, either through a spark plug or a petcock opening, so that the position of the piston may be checked. The valve covers should also be taken off, so as to ascertain when the piston is about to go down on a power stroke. This will be when both valves have remained closed on the upstroke immediately preceding. Having ascertained this, see if the

provision for fastening the timer on its shaft coincides with this setting. If any special arrangement has been made for preventing the timer from rotating on its shaft, this should be the case, or at least it should come very near one way or the other, and if so, the timer should be fastened in its original position. Also look to the timer contacts and spring, and to the vibrators of the coils, as unusual delay in the action of either of these parts often accounts for a great loss of power.

The one-inch carbureter is plenty large enough for the engine in question, and as numerous motors run very successfully with a carbureter in the position you mention, the arrangement is hardly to be condemned on that account alone, although, in our opinion, dropping it a foot or so in order to take advantage of the greater length of the manifold will make the mixture more homogeneous and freer from liquid gasoline and might prove a more satisfactory arrangement. Using hot air might also be an improvement.

The valve-timing should also be carefully checked in the same manner; that is, with the aid of the wire mentioned to determine the piston's position and with the valve covers off to note their movements. Beginning with the power stroke for which the ignition has been set, see that the exhaust valve opens at a point about 15 to 20 per cent. of the length of the stroke from the lower end and remains open until the following upstroke has been fully completed, when the inlet valve should rise, remaining open until the piston has passed the lower dead-center and has risen to a point about 10 to 15 per cent. of the length of the stroke from the bottom. If there be no flywheel marking to aid in checking this, the wire will be found valuable, as it may be marked in fractions of the length of the stroke, or the marks may be made on the periphery of the flywheel as you proceed, beginning with the upper dead-center just before a firing stroke and measuring in degrees on the flywheel circle, the exhaust valve being given a lead of 30 to 40 degrees and the inlet 20 to 30 degrees late in closing. Unless something has happened to disturb the position of the cams on their shaft, the setting of the first cylinder will suffice for all, and we feel certain that with the valves and ignition properly timed you will have no further trouble from lack of power.

### ECONOMY OF FUEL OR IGNITION CURRENT.

Editor THE AUTOMOBILE:

[1,192.]—A number of "Letters Interesting and Instructive" have dealt with the subject of current consumption of coils from the standpoint of battery economy, but not much is said about fuel economy.

Is it not true that some of your correspondents over-rate the importance of reducing current consumption to the minimum, or, in other words, will a coil do its maximum work when adjusted to consume the minimum amount of current? Is it not more economical to adjust for the hottest possible spark and thus reduce fuel bills, at the expense of battery bills? How much current per unit should a Splitdorf coil consume to do its maximum work?

The makers of mechanical storage battery chargers intended to be mounted on automobile engines very properly tell us of the advantages to be gained by their use. I would like to know what their disadvantages are, or at least the most serious and common ones. Does the vibration, dirt and water to which their position exposes them render them more or less unreliable or troublesome? Are they likely to injure battery by overcharging?

Pontiac, Ill.

SUBSCRIBER.

Extensive experiments have shown that beyond a certain point little or nothing is gained in actual practice by making the electric spark "fatter" or hotter. In every-day practice this is found to be about the minimum that the engine will run regularly on. The average autoist has no facilities for determining current consumption beyond a rather liberal range of error, and as the latter is on the side of excess rather than the reverse, the practice of adjusting coils to take the minimum consumption of current is economy in every sense of the word, and using more current would not be a gain in the fuel supply. The experiments referred

to showed conclusively that beyond the point where sufficient current was employed to properly ignite the charge there was no further gain in power nor saving in fuel consumption by using more current. Too many carbureters are poorly adjusted, and this accounts for a great deal of waste that is only too often put down to poor efficiency on the part of the engine. The latter will run better on a minimum fuel charge and do better work. We cannot say how much current any particular coil will require without putting it to test, but any well made coil will operate under very favorable conditions on as low as .25 ampere. As the conditions vary, this will increase, but on a properly kept system it should not exceed .50 to .75 ampere. Some coils are very poorly designed and cannot be made to operate satisfactorily on less than 1 to 2 amperes.

The difficulty with any direct-current generator on an automobile engine is that of maintaining its speed within a reasonable latitude of the r. p. m. rate at which it gives its normal output. A well built dynamo of this type will operate at as low as 1,500 r. p. m., but to get this speed at a low engine speed it has to be run from the flywheel or geared up several times in some other manner. When the engine reaches this speed the dynamo would be making anywhere from 6,000 to 10,000 r. p. m. and immediately be burned out if it were not for the governor. Sensitive and reliable governors have been adopted, but the system is not looked upon with great favor by many designers. Vibration, dirt and water has no effect on the generator, as it is usually "ironclad," i. e., completely inclosed, nor is the battery liable to be overcharged, as an automatic cutout is generally employed to prevent damage either from this cause or from stopping, which would otherwise allow the battery to discharge itself.

### DIFFERENT OPINIONS ON LUBRICATION.

Editor THE AUTOMOBILE:

[1,193.]—My chauffeur holds that there being three divisions in a six-cylinder engine crankcase, and oil supposed to be in these three divisions, that, should one of these be empty, the bearing at that part of the crankcase will run hot. I differ with him, and state that this would practically make no difference at all; that if there was plenty of oil in even one division, this would be beaten up into a mist by the rapidly revolving crankshaft, and this mist would permeate every part of a crankcase.

The chauffeur quoted a case to me of a six-cylinder car here that he knows of, the back bearings of which melted out in the manner described. I assert that if the back bearing was melted out, it was because there was not sufficient oil in any part of the crankcase, which any part of the crankshaft could reach, consequently there was no mist of oil to reach that, or any other part of the bearings, and that if he had driven very much further the other bearings would have melted out also.

The chauffeur also states that the raising of the springs in the back part of the chassis by putting a block under them would so disturb the level of the engine that the oil would be constantly in the front compartments, and not behind. I stated that this was manifestly ridiculous, because every little inequality in the road, which the front wheels surmount, would more than compensate for the difference of an inch or two rise in the chassis behind, and I pointed out to him that in going up or down a steep hill, or over a rough road, any raise of a couple of inches in the back springs counts for little or nothing in the level of the engine. He then asked, Why is the crankcase separated into compartments? And I said that, after all, it is desirable to have the oil evenly distributed, and that it costs practically nothing to make those divisions. Will you please state which is correct?

CHAUFFEUR.

Toronto, Ont.

Your chauffeur is correct in the stand he takes regarding the oil level in the crankcase. A high-speed engine not only runs very fast but gets very hot, and requires something considerably more substantial than a mist or spray of lubricating oil to properly oil its main bearings. Moreover, a six-cylinder engine is very long and it will be quite evident that if there were only oil in the forward compartment this would be of very little benefit to the rearmost bearings, unless the quantity in the forward ones was excessive and one over-

flowed into the other. This rear bearing does the major part of the work and is usually made much larger; consequently, it not only has to have more oil proportionately, but the importance of a constant supply is also greater, as otherwise it will cut or melt out sooner.

The instance that your driver cites is not an uncommon one and would be quite possible with the normal supply of oil in the front compartment, and probably with this quantity in both the front and middle compartments, as the partitions may be quite high. Therefore it does not follow that the crankcase as a whole was dry. Even with a very little oil, the result of the splash is more than a mere mist.

Your driver is also correct in his contention that raising the rear part of the chassis will disturb the engine level and might interfere with the oiling, unless provision was made to counteract it. You forget that every little rise of the road is both up and down, so that one counteracts the other, whereas, an inch or two rise of the rear of the chassis is always in one direction. To put it in common parlance, "it is working all the time." The crankcase divisions are for the purpose of preventing the oil from shifting from one end or the other, due to inequalities of the road or climbing or descending hills.

### SOME PLANETARY WHYS AND WHEREFORES.

Editor THE AUTOMOBILE:

[1,194.]—The instructor of an automobile school at which I was a student gave us the following problem to work out by calculation: If in a planetary gear the crankshaft makes three revolutions each time the rear wheels make one at high speed direct drive, how many revolutions will the crankshaft make at low speed each time the rear wheels go round once? The internal gear has 66 teeth, pinions on sprocket 21, driving gear 24 teeth. We gave it up. The instructor told us how to do it, but could not explain at all satisfactorily the why and wherefore, and I can see no reason for his method, which is as follows: Divide the number of teeth of internal gear (66) by the number of teeth on pinion (21), which equals 3 1-7. Then divide number of teeth on driving gear (24) by number of teeth on pinion (21), which gives the quotient 1 1-7. Then multiply the two quotients, 3 1-7 by 1 1-7 = 3 29-49. Multiply this product by 3 to find the number of revolutions the crankshaft makes each time the rear wheels make one. Answer, 10 38-49. Is this correct?

In studying the planetary gear itself, I could see that the driving gear made an extra revolution, but could not and cannot see exactly why and how it does it. You say, in your answer to letter No. 1,138, in your issue of February 6, "It will be evident that the central gear will have to make one more complete turn to drive the planet round its orbit than the direct relation between the driving gear and internal gear." Will you please explain?

How can I find out about the roads and hotels between Boston and Deerfield, Mass.? As one of the party is not very strong, the daily runs could not be long, and the hotels would have to be comfortable.

H. L. JONES.

Roxbury, Mass.

It will be apparent that when two toothed wheels are in contact and one drives the other, the speed of the driven wheel will depend both upon the speed of the driver and upon the relative sizes of the two wheels. For instance, if the driver runs 100 r. p. m. and both are the same size, the driven will also make 100 r. p. m.; if the driven pinion be half the size, it will make 200 r. p. m.; if twice the size of the driver, 50 r. p. m. Hence, dividing the number of teeth in the driven wheel by the number of teeth in the driver will give their relative speeds. In the case of the planetary gear the planet, or pinion, acts as an intermediate driver, so that the first operation mentioned gave the relation between these two and showed that the pinion made 3 1-7 revolutions for every one of the internal gear. The second division showed, as a result, that the pinion made 1 1-7 revolutions for every turn of the driving gear, and the product of the two would give the number of turns the crankshaft made for each revolution of the internal gear. The gear ratio of the car being 3 to 1 on the direct drive, multiplying this product by 3 would give the number of turns of the crankshaft on the low gear. Regarding the second query, it will be evident that if the

driver and the pinion were both the same size, the pinion would make one turn for every revolution of the driver, as already explained; that is, assuming the pinion to be free. But it is not, as it meshes with the teeth of the internal gear as well as with those of the driver, hence its travel is restricted by the former and for every turn of the driver the pinion makes less than a complete turn, amounting to one complete revolution of the driver in the time taken by the planet to traverse its orbit, or the internal gear.

The best route to Deerfield from Boston is via Worcester, 44 miles; Springfield, about 65 miles, and Deerfield, 30 miles, taking each of these stretches as a day's run. Full information in detail on all New England routes is given in the Official Automobile Blue Book of the American Automobile Association. This gives the nature of the roads, exact distances, all turns, hotels, garages and the like.

### HOW ABOUT IT, MR. DESIGNER?

Editor THE AUTOMOBILE:

[1,195.]—Is it necessary for a designer to have all the different formulæ by memory, without reference to books or written formulæ while he is at his work? I would like to get all the information I could about this. How many hours a day do designers work—that work for automobile companies? What is the best book or set of books, in your estimation, for designers' work, and the price of same? Do they have on the market tables or scales for finding the decimal equivalents of eighths, sixteenths, thirty-seconds, etc., parts of an inch?

J. L. BENEDICT.

Lehmaster's, Pa.

Just how much an automobile designer remembers, that is, constantly carries in mind, of his mathematics, is a matter that depends very largely upon the personal equation. Some men are able to carry a great deal more in their heads than others, though it is safe to say that in making calculations involving the use of anything but the commoner formulæ, it is customary to use an engineer's pocketbook, which contains a mass of technical information in form for quick reference. The designer also employs other reference works and data, whether his memory be good or bad. It would be a waste of gray matter to attempt to carry "under your hair" a great deal of stuff that is preserved far more accurately and in better form on the printed page. A designer's work depends upon how busy he is at the time; he may put in 20 hours out of 24 when rushed, but ordinarily keeps the usual office hours of 9 to 5. So far as we know, there is no book, or set of books, especially written for the use of the automobile designer. A good general knowledge can be obtained from Homan's "Self-Propelled Vehicles" and Hiscox's "Gas, Oil and Gasoline Engines," which will be mailed at \$2 and \$3.50 respectively. You will find this in any engineer's pocketbook, such as Kent.

### REMEDIES THAT GARAGEMEN ADVOCATE.

Editor THE AUTOMOBILE:

[1,196.]—Let me ask a question, to be answered in "Letters Interesting and Instructive." Usually the front wheels of an automobile are slightly nearer together at the bottom than at the top. Suppose that after some use this difference disappears. Is that condition of any serious consequence? And if your garage man advocates having the front axle bent so as to restore that difference, is it advisable to do so, and where can it be properly done?

Cambridge, O.

FRED. L. ROSEMOND.

The mere fact that the wheels were in this condition would not be serious of itself, but the fact that they had gradually assumed that position might be indicative of serious trouble. The object of placing the wheels slightly out of the vertical, inclining outward, is to give them a better grip on the road in order to facilitate the steering, which will become more difficult and less certain as they approach the perpendicular. It would look as if the bearings had worn, or the spindles or steering knuckles on which they turn had become bent. The wheels should be removed and these parts examined and any defect of this nature remedied. Bending the axle to



compensate for such a condition would merely be making a second defect to remedy the first, unless the cause is primarily due to a bent axle, which may also be the case.

#### WHAT CAUSES THESE EXPLOSIONS?

Editor THE AUTOMOBILE:

[1,197.]—Through "Letters Interesting and Instructive," please explain why natural gas and air will cause an explosion when pumped together under pressure in the same pipe line. There have been two explosions at the same place here within two weeks. An air compressor is used to pump air during the day and help out the gas pump at night. The explosion occurs at the time the gate is opened which turns the gas in about 100 feet 8 inch line which contains air. The gas pressure on the discharge line is about 150 pounds.

Shinglehouse, Pa.

HERBERT MCGREGOR.

Natural gas and air will form an explosive mixture when present in the proper proportions, just the same as gasoline vapor and air, or any other hydrocarbon. It seems evident that permitting the gas under pressure to enter the pipe containing air sometimes creates such a mixture, but that ordinarily this does not occur, which would explain the infrequency of the explosion. It also seems evident that the pressure of 150 pounds to the square inch is sufficient to ignite such a mixture, which would explain its explosion whenever it happens to be present. Some way of permitting the air to escape as the gas was admitted so that the two would not combine under pressure would provide a remedy.

#### A PROBLEM IN STORAGE BATTERY ETHICS.

Editor THE AUTOMOBILE:

[1,198.]—We would like to ask you about the storage battery we have on our engine. We bought it with the auto and used it about 500 miles. It got weak and we then used dry batteries the rest of the season. We left the storage battery just as it was all winter, and in the spring we had it recharged with chemicals and electricity. But the chemicals all leaked out. Then we took off the bottom and found that all the glass jars were broken, three in all there was. We then took it apart and found that one jar was half full of wax, another one-third full, and the other one-half full. We took all the wax off; tied the plates together with the strip of wood between and left them that way this winter. Now, what we would like to know is if we get new jars next spring and put it together again and recharge it with chemicals and electricity, will it be as good as ever, or would you consider it worthless after going through what it has. Was it not strange that it worked at all with so much wax in each jar? It worked well for 500 miles.

Bemidje, Minn.

THORN BROS.

If none of the active material has fallen out of the plates, and the elements are properly assembled and charged, they may give service again at a reduced efficiency. It would not cost much to try the experiment. Probably the cells operated for 500 miles before the jars broke.

#### MAGNETO VERSUS THE ACCUMULATOR.

Editor THE AUTOMOBILE:

[1,199.]—What is the advantage, if any, of a magneto over a good storage battery? I have a four-cycle, four-cylinder engine, and if a magneto would be better than a storage battery, I will get one.

Ehrichsville, O.

ALEX. ROBINSON.

The necessity for recharging the accumulator at certain stated intervals, whether it be in service or not, is accounted one of its greatest disadvantages, and the fact that unless watched it may need recharging through exhaustion from service at an inconvenient time is another. However, the storage battery is a very reliable and simple method of providing ignition current on a car, and where given a modicum of regular care will carry out its rôle at a fraction of the expense of a magneto, though, of course, the expense for recharging is a more or less constant item and depreciation is relatively high. The magneto is probably less subject to trouble than any other form of current supply, though despite its simplicity it is not as generally understood as it should be. Its first cost is relatively high, but its upkeep is merely nominal, and it has a very high factor of reliability and efficiency.

#### TESTING THE IGNITION COILS.

Editor THE AUTOMOBILE:

[1,200.]—I wish to know whether the ordinary volt and ampere-meter, such as is used to test the voltage and amperage of dry cells, can be used to test how much current is being consumed by the coil, or whether it is necessary to get a special coil current indicator. If, as I am informed, the former can be used, what points of contact do you bring into the circuit? The plug hole and the vibrator, I imagine, or is it possibly the vibrator and the metal of the car? Further, what is the maximum the coil should consume for a two-cylinder, 12-horsepower car?

Asheville, N. C.

CHARLES L. MINOR, M.D.

You will find an answer to your question in the last issue of THE AUTOMOBILE, i. e. February 6, letter No. 1,135 on page 179. The current necessary depends on the coils and vibrators, not on the size or power of the engine. A properly designed, well-built coil that is correctly adjusted will work satisfactorily on .50 ampere, or less, as it has been shown that it is possible to operate on as low as .10 ampere, but this calls for very favorable conditions.

#### FURTHER TESTIMONY AGAINST THE NOZZLE.

Editor THE AUTOMOBILE:

[1,201.]—In letter No. 1,147, Mr. Bates says he agrees with Mr. Fay regarding the needle valve on the carbureter. He tells of making a nozzle with an opening smaller than a No. 60 drill. A hole of this size is going to get stopped up quicker than any needle valve opening I have ever seen. And, who carries with them such a thing as a needle to clean out such openings? On the other hand, it takes a man who is equipped with a shop to put on these nozzles, as very seldom will two engines take the same size nozzle. For this reason the needle valve has been adopted. The nozzle must be a certain height and the float adjusted for that height nozzle. Gasoline should be strained and also a strainer be placed between carbureter and gasoline tank.

I think it is safe to say that the gasoline mixture is lighter when the engine is running fast than when at slow speed, provided the carbureter is set for slow speed and the needle remains in one position. To back this statement, let me ask why it is that Schebler is going to the expense of making a carbureter on which there is a mechanism to open the needle valve as the carbureter throttle is opened? They also have a compensating air valve on this carbureter.

I have not inspected any foreign cars, and I do not remember any high grade cars without a needle carbureter, especially the newer models.

Chicago, Ill.

C. S. VIALL.

#### PERMANENTLY POLISHED AUTO MATERIALS.

Editor THE AUTOMOBILE:

[1,202.]—The letter of M. G. Augspurger, in your issue of January 16, No. 1,108, brings up again a question about which much has been written and very little accomplished. The needs of automobile construction have brought about changes and improvements in materials which ten years ago would have been considered impossible, and it would seem that some of our American metallurgists would be able to suggest some practical substitute for brass, which would not oxidize or tarnish and yet be strong and ductile enough to be used in the manufacture of accessories, levers, etc.

I have heard of a system of heat treatment with zinc and aluminum which is used in England for rendering steel non-oxidizing, and understand that it is not a plating system, but that the surface of the metal is mechanically changed to produce the quality.

If any of your readers have information with reference to this or any other system of giving polished metal these qualities I am sure that a general discussion of the subject would be beneficial to the trade.

Chicago, Ill.

OWEN THOMAS MOTOR CAR COMPANY,  
W. Owen Thomas, vice-president.

#### INFORMATION ABOUT GEORGIA ROADS.

Editor THE AUTOMOBILE:

[1,203.]—Answering "H. L. Y.," of Toledo, O., in letter No. 1,152, wish to say that I live near Waycross, Ga., and have owned a Cadillac runabout for the last two years, and while the majority of South Georgia roads are a little sandy, there are very few that this little car will not take on the "high." There are several cars owned by country people near me, and they have no trouble going anywhere they want to in this and adjoining counties. And these cars are nearly all low-powered runabouts.

Will be glad to have a letter from "H. L. Y.," provided he wishes any further information.

Fairfax, Ga.

H. D. BUNN.

# HINTS AND SUGGESTIONS FOR THE AUTOIST

WE do not think the penetrating powers of kerosene are fully appreciated, says *Autocar*. When a nut or bolt sticks and cannot be moved with a key as long as one dare use for the particular nut or bolt, kerosene is the remedy. It should be squirted all round the stubborn thread. From time to time we have been told by automobilists to whom we have suggested this remedy that it has failed. Except in quite unusual cases this failure has been due to lack of patience. It must not be expected the moment the kerosene has been applied to the thread that the trouble will be over. The nut or bolt should be left for several hours for the kerosene to soak in; then it is almost certain to penetrate. When the nut is in such a position that kerosene runs away without soaking into the thread, it is necessary to fix up some little dodge for stopping this. A simple way is to wrap a rag round the nut and thoroughly saturate it with kerosene, or, in extreme cases, to file a little channel on or about the nut or bolt head, so that some of the kerosene is retained and left to soak into the thread. An excellent example of the penetrating and freeing power of kerosene was afforded the other day on a car having cups over the valves taking the form of large gunmetal plugs, and screwing into the valve chambers by a box spanner with a two-foot lever. It would have been possible to get a longer lever, but it was not considered safe to apply any greater force. We contented ourselves by giving the plug a copious dose of kerosene and leaving it till the next day. After twelve hours soaking the plug came out quite easily.

### A Hint on Fitting Piston Rings.

When new piston rings are being prepared it is a common practice, when they are almost ready, to test their size in the base of the cylinder, writes a correspondent to *Omnia*. It should be noted, however, that the cylinder has had less wear at this point than at any other position, and if it is desired to obtain a perfect fit care should be taken to first of all reduce the unworn part of the cylinder to the exact diameter of the upper portion worn by friction of the piston rings. The reduction may be made by the use of a cylindrical block of wood covered with fine emery cloth. When by this means a uniform diameter has been obtained along the entire length

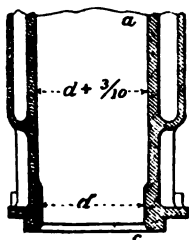

UNEVEN WEAR OF CYLINDER.

of the cylinder, a ring fitted at the base will be gas-tight in every other position.

### What to Do When the Motor Seizes.

A seized motor, generally looked upon as a serious accident, need not necessarily be a very terrible affair. If it should happen that through neglect or any other cause the motor is allowed to run without lubrication, heats up and stops, so that piston and cylinders form as it were one block, the best method is to open compression cocks, or if there are none take out spark plugs, or dismount the inlet valves, then pour in a liberal quantity of kerosene. The automobilist may exclaim that kerosene is difficult to find on a car; but it should not be so. It is so useful in a hundred different ways that a couple of pints should always be carried. After the kerosene has been poured in, rest a while to allow it to penetrate, then try to turn the motor over. If after a liberal soaking with kerosene it is still impossible to turn the engine, the car should be put into low gear, the clutch left in and the vehicle vigorously pushed by as many willing hands as are available. Generally such treatment will have the desired effect, the kerosene will

work its way round the cylinder walls and allow the motor to be turned over as readily as usual.

If all this should prove unavailing it can safely be concluded that there is something seriously the matter with the motor, and humiliating though it may be, the best plan is to slip into neutral, get a horse, and proceed in this undignified manner to the nearest auto repair shop.

After the kerosene has done its work of releasing the locked pistons, it should be remembered to empty the crankcase by the cock provided for that purpose in the base. Then add the necessary quantity of lubricating oil and proceed.

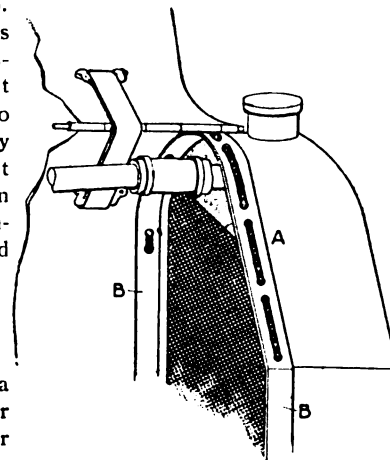

BINDER TO PREVENT RATTLING.

### To Prevent the Bonnet Rattling.

A bonnet which has a tendency to rattle under the vibration of the motor can be readily silenced by piercing a series of holes in the band of metal on which the bonnet rests and threading through a strip of leather, as shown in illustration. The hood thus resting on leather and not against metal cannot possibly produce a noise. The improvement is so simple any automobilist can effect it.

### External Causes Sometimes the Reason.

It may seem an anomalous statement to make, but from the incident given below it will be evident that causes within the motor itself are not always responsible for a failure to start or continue running. On the occasion in question, the motor invariably responded to cranking every time it was turned over on the compression stroke, sometimes taking up its cycle to the extent of making two, three, or even half a dozen complete revolutions, which should have been sufficient to show that it was in working order, but the true cause was never surmised. It is well known that the greatest drawback of the internal combustion motor of any type is its disability to start under load, and the reluctance of this particular motor to do its duty arose solely from the fact that it was unable to get up sufficient headway to overcome the resistance applied to it. The latter was finally located in a dragging band of the planetary change-speed gear and merely easing this off a bit righted matters at once.

This might seem to confine such cases to cars equipped with this type of change-speed gear, but a little reflection will suffice to show that this need not necessarily be the case. It is only the momentum of the flywheel that bridges the gap between the power strokes in the engine, but until it assumes a certain speed not enough power is stored in it to move the working parts sufficiently to bring about the next impulse. Naturally only a very light load is required to discourage the motor to this extent in its initial stages of starting, and it matters little how the load is applied. Under the head of external causes might also be included some deflections as arise from the introduction of foreign bodies, usually in the gasoline, which cause a stoppage of the fuel supply, though this was not the intention in making this subdivision, as trouble of this nature really belongs to a description of carbureter ailments.



"CHOP IT IN TWO OR CUT YOUR WAY AROUND."



THREE-CYLINDER FERRYBOAT AT DEPOSIT, ALA.

## HOW THE OLDSMOBILE "MUDLARK" FOUND THE WAY

By ONE OF THE TOURISTS.

ONE month ago the idea of autoing from Greater New York to the Gulf of Mexico was regarded as almost or quite impossible at any season of the year. As a winter cross-country run there appeared to the experts little likelihood of a successful finish to the project. In exactly three weeks after the start was made, however, Ralph R. Owen, of Cleveland, drove his famous 40-horsepower Oldsmobile *Mudlark* from Broadway, New York, to Canal street, New Orleans. The dream for a decade of enthusiastic autoists had come true. The feat had been accomplished in the face of weather and road conditions which seemed to willfully combine forces for the purpose of preventing a happy consummation of Mr. Owen's ambition.

When the *Mudlark* left Columbus Circle, New York City, early in the afternoon of Sunday, January 26, the streets of the metropolis were hidden beneath two feet of snow, and the route carried the tourists over the thick white carpet to Cleveland, nearly seven hundred miles away. Four days were consumed in negotiating this distance, and blizzards did their part in obstructing the progress of the hardy travelers. Six passengers in all braved the weather from New York to Albany, the first day's run, but at that point two returned to the allurements of Broadway.

A blizzard of snow, rain, sleet and a sixty-mile gale played an obligato to the purr of the motor throughout the second day, but at evening the tourists thawed out beside the radiators at Syracuse.

Tradition and railroad guide-books agree that beautiful scenery prevails along the Mohawk Valley, but the travelers saw none of it owing to the thick drop curtain of snowy whiteness which obstructed the view at a distance of ten feet in all directions.

On the third day, Tuesday, the car travel led to Buffalo in an encore of the previous day's storm, over roads which at that time were regarded as very bad, but which, in the light of later experiences, are recalled as boulevards.

### Progress Through Ohio with the Thermometer at Zero.

Hurdling the hills to Ashtabula, O., was the next day's undertaking. Extreme cold and heavy fall of snow made the day's work a difficult one, but 150 miles were made between 11 o'clock in the morning and 8 at night. On Thursday a short and easy run was made to Cleveland, the home of two of the party, and most of the day was devoted to entertainment, rest and good wishes of friends. Snow lessened in depth rapidly as the car headed southward, and the first mud of the tour was encountered. Several miles of soft going

were covered at a slow pace. The tourists hoped and believed in their innocence that nothing worse would be discovered in the south country, but were destined to take a post-graduate course in soil study later on.

The route wound its way through Bucyrus, Marion and Delaware, and aside from bitter cold weather the touring conditions were most favorable. Before reaching Columbus, however, a heavy cold rain began to fall, and as night had come on the party was glad beside the steam heat at the Chittenden Hotel. Saturday morning brought another passenger, who was invited to go as far as he pleased. His evident intention was to travel about ten miles in the *Mudlark*, for he had absolutely no extra clothing, but it was eight days later and the car was ready to leave Huntsville, Ala., before he said "Good-bye" and turned back to the north. Rain prevailed during the day's run from Columbus to Cincinnati. The mercury hovered around the zero mark for the first time in years at Porkopolis while the tourists huddled close to the heating apparatus. Cold weather, in fact, was the chief discomfort of the northern portion of the tour, but later on the "troopers" gladly would have swapped the miserable roads of the South for the lowest temperature of the North.

### Our Entry Into the Sunny South at Covington, Ky.

Early Sunday morning, with the thermometer registering but one degree above zero, the party hustled across the bridge of the Ohio river into the alleged "Sunny South." It was too cold to jest, however, and the roads were found to be good for several miles. Lexington, Kentucky, served lunch. Two hours were lost but not wasted in visiting the Haggin stock farm, where the *Mudlark* was photographed in a group with Salvitor, the famous old race horse, now twenty-one years of age. Two epochs of speed, the race horse and the automobile. Tire trouble, which had been spasmodic all the way from New York, now developed alarming symptoms, but the genuine epidemic did not break out until a day or two later. Then it raged in a high fever until New Orleans was reached, where with one gigantic explosion the trouble was over, for little remained but bare wheels. Fingering the cold tools and rebellious rubber while the mercury is below par is not conducive of buoyant disposition, but everybody forgave the rubber goods makers when the lights of Louisville loomed to leeward at supper time.

The *Mudlark* had now traveled 1,230 miles in a week of comparatively easy going, and with but 800 miles to cover the travelers gulled themselves into the belief that another week would register them at New Orleans. Poor, deluded

strangers in a stranger land! Tooling out of Louisville on Monday the car passed between a long funeral and a wagon loaded with caskets. Everybody denied the slightest trace of superstition, nevertheless four days were consumed in reaching Nashville, just a decent day's run southward. Part of the delay was due to the hospitality of the citizens of Bardstown, Ky., who persisted in showing us "The Old Kentucky Home," the birthplace of Abraham Lincoln, historic churches, and all the glories of the famous old township, including a liberal number of distilleries. During the second day from Louisville the highways were heavy and mountainous and progress slow. C. W. Thatcher's mule-team party of "good roads" promoters was overtaken, and a good roads club of 200 members was organized at Buffalo, Ky.

Bowling Green was reached at night, after many pictures of Mammoth Cave and other interesting places had been taken. A miracle marked the arrival at Bowling Green—a heavy snowstorm was astonishing the natives of southern Kentucky and all business was suspended in honor of the double event. Snow changed to rain in the night, the rivers burst their banks, and the car was stalled between streams for thirty hours at Portland, Tenn. A rescue party from Nashville attempted to meet us with a much-needed supply of tires, but likewise was stalled, and there was nothing to do but wait for the ebbing of the tide. At Nashville on the following day the tourists received further evidence of Southern hospitality, and were royally entertained at the Wautaugo Club. In this connection, it should be stated that a warm welcome was accorded the party at many Northern cities, notably Cincinnati, Columbus, Cleveland and Louisville. The kindest courtesy would have been a warm, clean bed, but the friends along the route enjoyed doing much more than was desired or expected. At Nashville, too, dire hints of bad roads were proffered, but caused little alarm. Was not the engine pulsing perfectly? Were not new tires plentiful, and the price at hand? Still, four days were relegated to the past tense before the beautiful streets of Birmingham were traversed.

#### A Striking Example of Southern Hospitality.

Huntsville, Ala., was the sleeping place on the first night, but it did not appear on the horizon until the moon rose at midnight. Meanwhile the tourists had forded streams which extinguished the lights and stopped the engine. Scouts waded the rivers with lanterns to find the road on the other side, while animals objected noisily to the intrusion of the woods. The pathway was a tomb with walls of thick pine timber in its natural state. Just beyond this point the travelers received the most memorable example of Southern hospitality of the entire voyage. Nine o'clock in the evening, with nothing to eat since early breakfast! A cup of coffee would offset the chill from the malaria-breeding marshes. A hut

was in sight. Answering the knock came a woman who apparently had been unable to meet the atmospheric condition and beat them backward. Seven small children, gaunt and hungry-appearing, huddled around the inevitable Southern fireplace. Yes, certainly, she would make a pot of coffee. While the hostess prepared the hot drink an inventory of the two rooms was taken by the travelers, merely because everything was in plain view. Six dollars would have been an extravagant price for all the household effects in sight, including two broken banjos. Without a banjo no Alabama home is completely furnished. There may be no bed, but there must be a banjo. The coffee was accompanied by corncake. No sugar, milk or butter in evidence. Everything she had to offer was before the hungry ones. It was all the woman had to proffer, yet, in the face of abject poverty, the first sign of recompense was an insult to her. "No charge, sah," she said, and no price could be arranged. But the kids got \$5.

#### Everywhere There Was Mud and Rain in Alabama.

The second Sunday found the *Mudlark* in the mountains and valleys of Alabama with a dreary, cold rain prevailing. Mud, like cement, prevented fast travel, and the one redeeming feature was the absence of horses on the alleged highways. In the South horses are not on neiging terms with the automobile, and fastest time can be made at night or early in the morning. During the day the passage is punctuated with continuous stops to lead horses past the car. Night found the travelers at a mountaineer's home, with supper of hog, hominy and hoe-cake. An attic room with rain beating merrily on the roof was not a bad place for sleep. On the following day enormous trees were discovered directly across the only road down the mountain and a private path was carved through the thicket, without asking permission of the owner, who might have been a thousand miles away. Twenty-five miles from Birmingham a swollen creek swallowed the car and passengers. Block and tackle pulled the car out of the bath. The motor refused to balk, and twenty-one miles of the best road in the country were quickly dispatched. We were in Birmingham, the most wonderful city in America for its population. At this city all brands of advice could be obtained free, but as a choice of evils the party determined to try the road direct to Meridian, Miss. Then came the deluge. Mud, deep water, and more mud. The valley is a chamber of horrors. Twenty-five miles of good roads as a teaser, then a plunge into red mud so sticky that it cannot be thrown from a shovel. At one point the car was pulled down hill on a 25 per cent. grade, using block and tackle. Somebody had told us that Meridian could be reached in a single day. The *Mudlark* raced (?) into Tuscaloosa, Ala., that night, less than a third of the distance to Meridian.

On the following morning a start was made very early, but



FAIR TYPE OF MISSISSIPPI ROADS NEAR HATTIESBURG.

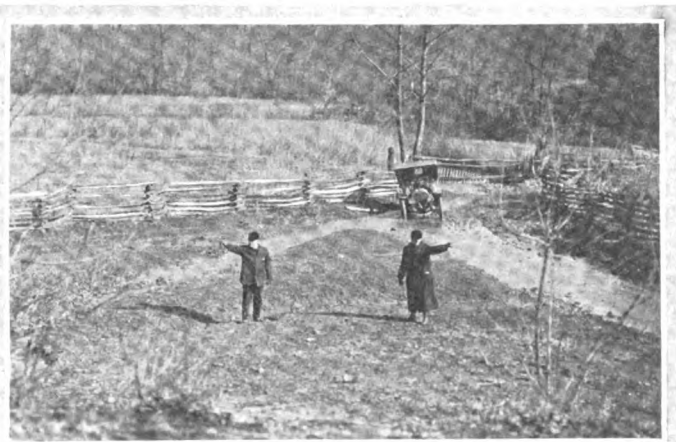

NEAR TUSCALOOSA, ALA.—WHICH ROUTE FOR LEAST MUD?



after eighteen hours of continuous travel the car stopped at Eutaw, thirty-five miles away. This may be a reverse English record for American touring. During this day the block and tackle were used twenty-two times and negro guides showed the way along forest paths through plantations. From Eutaw to Meridian, Miss., the only change in road conditions is in the color of the mud. The color scheme changes from red to black, but the clinging qualities of one is equal to the other. At Meridian rains fell in a group, trains were stalled in all directions, telegraph wires were down, and prospects were poor for immediate progress. Within a few hours, however, the sandy soil of that section absorbed the water, and, after reconnoitering for several miles in many directions, it was decided to head for New Orleans by the most direct route and take chances. The Crescent City is but a decent day's journey, according to motorists' measurements, but under the conditions we occupied two full days and nights.

#### New Orleans Accorded the Tourists Generous Welcome.

The welcome accorded the tourists at New Orleans was worth all the weariness of travel, however, and everybody in the city seemed to have been watching the progress of the car

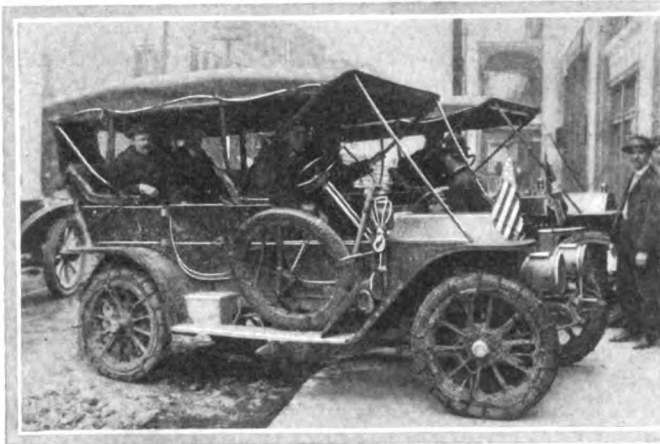

"MUDLARK" NO. 3 ARRIVES AT NEW ORLEANS.

from New York. The car and its intrepid driver, Ralph R. Owen, were cheered by crowds which blocked the streets, and only the police seemed unfriendly. "Move on" was the constant order, but the tourists had been doing that for exactly three weeks and it was easy to satisfy all concerned. A tour of the entire city was made, the *Mudlark* leading a parade of Oldsmobiles through parks, boulevards and alleys, which in New Orleans pass for streets. Monday, February 17, the tourists were royally entertained at clubs and hotels and in the evening immediately returned to the North. That the car reached New Orleans from New York with the motor putting softly and steadily as when it left the metropolis, speaks well for the development of the American automobile. The trip which was presumed to be impossible has been accomplished, and in the belief of the travelers, particularly Mr. Owen, who has made many American tours, would be a splendid route for the Glidden tour. Not impossible, but likely to eliminate nearly all perfect scores.

#### THREE RACES ON TARGA FLORIO COURSE.

PARIS, Feb. 17.—Three distinct races will be held in connection with the Targa Florio, May 7 to 10. Powerful touring machines will be provided for in 5.1 bore class; medium powered cars must not exceed 4.1 inches bore, where four cylinders are employed; voiturettes will be limited to 3.9 inches bore for a single cylinder. In addition to the Targa and the King of Italy's cup, \$3,000 in gold will be given to the winner. The first prize in the voiturette race is \$800.

## THE AUTOMOBILE CALENDAR.

### AMERICAN.

#### Shows and Meetings.

- Mar. 7-14.....—Boston, Mechanics' Building and Horticultural Hall, Boston Automobile Dealers' Association. Chester I. Campbell, manager, 5 Park Square.
- Mar. 11.....—Boston, Bay State Auto Association Clubhouse, First Quarterly Meeting, Society of Automobile Engineers.
- Mar. 9-14.....—Buffalo, Convention Hall, Sixth Annual Automobile Show, Automobile Club of Buffalo. Dal H. Lewis, manager.
- Mar. 16-21.....—Indianapolis, Ind., Annual Show, Automobile Dealers' Association.
- Mar. 18-21.....—Rochester, N. Y., New Convention Hall, First Annual Show, Automobile Dealers' Association and Rochester Automobile Club. Bert Van Tuyle, manager.
- Mar. 18-24.....—New Haven, Conn., Music Hall, Annual Show, New Haven Automobile Dealers' Association.
- Mar. 21-28.....—Toronto, Canada, St. Lawrence Arena, Automobile Show. R. M. Jaffray, manager.
- Apr. 5-12.....—Montreal, Canada, Arena, Third Annual Automobile and Sportsman's Show. R. M. Jaffray, Mgr.
- April 6-8.....—Denver, Mammoth Rink, Annual Automobile Show. G. A. Wahlgreen, manager.

#### Race Meets, Hill Climbs, Etc.

- Mar. 2-7.....—Ormond-Daytona, Fla., Automobile Club of America.
- Mar. 18-19.....—Savannah, Ga., Savannah Automobile Club.
- Apr. 24.....—Briarcliff Trophy Race, Westchester County, N. Y. Robert L. Morrell, chairman.
- May 4-5.....—Harrisburg-Philadelphia and Return, 150-mile Endurance Run, Motor Club of Harrisburg.
- May 15.....—Chicago, Algonquin Hill Climb, Chicago Motor Club.
- May 16.....—Hartford, Conn., 200-mile Endurance Run, Automobile Club of Hartford.
- May 30.....—Bridgeport, Conn., Sport Hill Climb, Bridgeport Automobile Club.
- June 24-27.....—Chicago, 1,200-mile Reliability Run, Chicago Motor Club.
- Sept. 14.....—Chicago, Annual Economy Run, Chicago Motor Club.

### FOREIGN.

#### Shows.

- Mar. 21-28.....—London, Agricultural Hall, Cordingley's Show.
- Mar. 26-April 4.—London, Olympia Industrial Vehicle and Motor Boat Show.
- May 17-June 2.—Moscow, Russia, International Automobile Exposition, Automobile Club of Moscow.

#### Race Meets, Hill Climbs, Etc.

- April 1-13.....—Monaco Motor Boat Races and Motor Boat Exhibition, International Sporting Club of Monaco.
- April 25-May 25—Industrial Vehicle Competition, Automobile Club of France.
- May.....—Paris, Competition for Agricultural Automobiles, auspices of "L'Auto." (Date to be announced.)
- May 1-31.....—Automobile Taxicab Competition, France, Automobile Club of France.
- May 10.....—Sicily, Targa Florio, Automobile Club of Italy.
- June 1-18.....—Reliability Trials for Pleasure Cars, Automobile Club of Great Britain.
- June 9-17.....—Touring Competition for the Prince Henry of Prussia Prize, Germany, Imperial Automobile Club of Germany.
- July 6.....—Voiturette Grand Prix, Dieppe Circuit (Automobile Club of France.)
- July 7.....—Grand Prix of Automobile Club of France, Dieppe Circuit.
- July 13-17.....—Ostend, Belgium, International Race Week, Automobile Club of Ostend.
- July 20-30.....—Ardennes Circuit Races and Coupe de Liederde, Automobile Club of Belgium.
- Aug.....—France, Coupe de la Presse, Automobile Club of France. (Exact date to be announced.)
- Aug. 29-30.....—France, Mont Ventoux Hill Climb, Vauclussen Automobile Club.
- Sept. 1-8.....—French Voiturette Contest, auspices of "L'Auto."
- Oct.....—Berlin, Germany, Gordon-Bennett Balloon Race, Aeronautical Club of Berlin.

A SCHOOLBOY'S ESSAY ON THE AUTOMOBILE

Topeka, Kan., has a ten-year-old hopeful whose sternly refuses to help him with his lessons or debates. name is Wendell Switzer, and he attends the Harrison School in that City. That the youngster is not sadly in need of coaching is evident from the argument he put up the other day in the school debate upon the momentous question, "Resolved, That automobiles are more useful to man than horses." His support of the affirmative side of the question is so original and unique that the same is worth publication in full. It is as follows:

First, I will mention that automobiles will run longer than horses. An automobile does not give you nearly as much trouble as horses. Very early in the morning you have to get up, dress, and go out in the cold and feed your horses, which is not at all nice, and then you have to wait a long time till they are through eating, which delays you; while an automobile you just have to fill with gasoline the minute you want to start. The feed for the automobile, which is gasoline, does not cost as much as feed for the horses, for the only feed there is for automobiles is gasoline, and the horse has to have corn, wheat, oats, hay, bran and other things, which raise higher and lower, but gasoline never changes its price much at all. And wheat is so valuable, and so is timothy hay, and you hardly ever get good wheat and corn. You have to take such good care of your corn or the crows will get it. And another thing is, that a horse can have only one horsepower, while an automobile can have forty or fifty.

If you do not give your horses good food, you cannot sell them for a good price, for they get weak and sick. Automobiles never get sick, which saves trouble. When a horse gets sick it is more liable to die than any other thing. You can get automobiles of all sizes, while horses are nearly all one size. You have to curry your horses, brush and wash them, which takes trouble. One of the hardest things of all about horses is training. That is very hard. Automobiles don't have to be trained, which saves trouble. To train a horse you must nearly risk your life, for you do not know what or when the colt is going to do. It is a very hard job. When a colt is first bridled up it does not know what to do. It jumps and rears, kicks, runs, and if you hitch one up to a new buggy, there will be nothing left of it, for the colt will do everything it can to get the harness off. The young colt is not used to having harness on, and it feels very miserable to him and he wants to get it off. The horses scare at street cars and rear up and sometimes break the buggy. Automobiles never get scared like horses. You have to hollow at the horse to make it go, while you just have to turn a crank to make an automobile go. An automobile tells us how far it has gone, or going, and how much gasoline it is using. A horse does not do that. It does not tell us how much flesh he is wearing off or how much breath it is using and don't tell us how far he is going, so we don't know when to stop and keep on going and wearing off flesh till the poor horse is nothing but skin and bones, which we call a skater, and make fun of the owner. Some people do not feed their horses, and drive them so much that they drive them to death. You can't run an automobile to death no matter how much you run them, which is better.

PRESENT SAVANNAH TROPHIES

Savannah in 1733. In unusual contrast is the scene on the other side of the central engraving. Here are shown automobiles of latest design at racing speed, with the date "1908." The convoluted stem of the cup has alanthus leaves in relief. The base is Corinthian. The ebony pedestal is octagonal in shape. Cotton bales surround it, affording room for the inscription of the names of the successive winners of the cup. The trophy is to cost \$1,800. Each of the cups owned by Mr. Van Keuren is to cost \$1,000.

ance of the winning drivers, will be presented to the club.

Whereas, the automobile is the practical forerunner of advancing civilization;

Now we, the Quaker City Motor Club, do hereby propose to enlist and enroll from among our members in good standing a sufficient number of capable and able-bodied men who shall agree to act as a volunteer motor corps.

This volunteer motor corps is to offer its services and machines, through the Quaker City Motor Club, free to the city of Philadelphia, the State of Pennsylvania and the United States government as an auxiliary force, in all cases of urgent need or dire necessity for the suppression of lawlessness and insurrection, or in the grave duty of repulsing foreign invasion in time of war. And,

Whereas, the Quaker City Motor Club is only actuated by true patriotism and love of country, we most humbly pray your best consideration and prompt acceptance of this sincere proposal.

Ratified and adopted February 20, 1908.

The offer of the motor corps' services, it will be noticed, was extended to include not only the city, but the State and the United States as well, as identical letters making the offer have been sent to the President, the Governor and the Mayor.

Among the other business of importance transacted at the meeting was the decision to change the club's quarters from the Majestic to the Walton. Three large second-floor rooms have been secured on the Locust street front of the hotel, and on special occasions additional adjoining rooms will be placed at the disposal of the club. The first meeting in the new quarters will be held Thursday, March 5, when a "house opening" will be in order.

KANSAS CITY CLUB BOOMING GOOD ROADS.

KANSAS CITY, Mo., Feb. 24.—So pronounced was the success of the Good Roads banquet, held January 15, that the members of the club are enthusiastic over continuing the work, and will hold a smoker at the Savoy Hotel, March 12.



OMNIBUSES FOR THE QUARTERMASTER'S DEPARTMENT, U. S. A., TO BE USED AT THE WEST POINT MILITARY ACADEMY.

The three cars represents one day's shipment from the factory of the makers, the Auto-Car Equipment Company, of Buffalo, N. Y. The cars are fitted up in an especially attractive manner, the upholstery being of hand-buffed leather, the windows, plate glass in mahogany frames, electric lights and lamps, electric signals, etc. Motor equipment is two Westinghouse vehicle motors, with 42-cell National Storage batteries, and the tires D diamond wire mesh base applied with side flanges of 36-inch diameter. In the daily operation they have to overcome a grade of 12 per cent. in a thousand feet.

after eighteen hours of continuous travel the car stopped at Eutaw, thirty-five miles away. This may be a reverse English record for American touring. During this day the block and tackle were used twenty-two times and negro guides showed the way along forest paths through plantations. From Eutaw to Meridian, Miss., the only change in road conditions is in the color of the mud. The color scheme changes from red to black, but the clinging qualities of one is equal to the other. At Meridian rains fell in a group, trains were stalled in all directions, telegraph wires were down, and prospects were poor for immediate progress. Within a few hours however, the sandy soil of that section absorbed the water after reconnoitering for several miles in many directions.

A. G. BRADLEY, Managing Editor  
 R. F. KELSEY, Associate Editor  
 C. B. HAYWARD, Engineering Editor  
 W. F. BRADLEY

**BUSINESS DEPARTMENT**

A. B. SWETLAND, Business Manager  
 LOUIS R. SMITH  
 W. I. RALPH, 1035 Old South Building, Boston, Mass.  
 FRANK B. BARNETT  
 C. H. GURNETT, H. E. WESTERDALE, 836 Monadnock Block, Chicago, Ill.

Cable Address - - - - - Autoland, New York  
 Long Distance Telephone - - - - - 300 Gramercy, New York

**SUBSCRIPTION RATES:**

United States and Mexico - - - - - One Year, \$3.00  
 Other Countries in Postal Union, including Canada, - - - - - One Year, 5.00  
 To Subscribers—Do not send money by ordinary mail. Remit by Draft,  
 Post-Office or Express Money Order, or Register your letter.

**FOREIGN SUBSCRIPTION AGENTS:**

ENGLAND:—Hiffe & Sons, Limited, 29 Tudor Street, London, E. C.  
 FRANCE:—Boyveau & Chevillet, 22 Rue de la Banque, Paris.  
 GERMANY:—A. Seydel, Mohrenstrasse 9, Berlin.

Entered at New York, N. Y., as second-class matter.  
 The Automobile is a consolidation of The Automobile (monthly) and the Motor Review (weekly), May, 1902, Dealer and Repairman (monthly), October, 1903, and the Automobile Magazine (monthly), July, 1907.

Copies printed in 1905	- - - - -	730,000
" " in 1906	- - - - -	791,000
" " in 1907	- - - - -	888,900

**A NATIONAL BODY OF STATE ASSOCIATIONS.**

Only through the combined efforts of local automobilists can acceptable local conditions be secured; only through the united endeavors of the automobilists of a State can reasonable State laws be assured; and only through the welding together into a national body of these State associations can the general good of automobiling be furthered and the day brought nearer when anything savoring of unjustness and oppression shall be improbable and impossible.

With a Federal Registration bill pending at Washington, and unusual and varied activities rampant in various States, the need of organization is apparent to all automobilists. No one club can be made powerful enough to encompass the needs of the diversified situation, and this opinion was that of the clubs which assembled at Chicago, March 4, 1902, and formed the American Automobile Association. The years that have passed since then have only confirmed this judgment in a country where centralized direction arouses determined disputation. Any attempt to establish a club autocracy would meet with a unanimous opposition and would do no good to that club which sought to assume the dictatorship of automobiling in this country.

A club is entitled to the right of way in its district as long as it conserves the rights of those whom it assumes to protect, and only when it is derelict in its duty has the parent body any reason to invade club precincts. But the automobilists of a city have a right to expect that the local club shall do all that it can to preserve the un-

led and uninterrupted use of the motor-driven vehicle. No injustice should be borne without protest. This country is one of magnificent distances, but when the era of road-building has fairly gotten into its stride—it is starting in a most convincing matter—the automobile will shorten mileage as easily as is the case in other Europe with its countries wherein highways deserve the name. Coincident with the making of the roads will be the enlarged capacity of supplying touring information, and certainly this cannot be better accomplished than by the accumulating and disseminating work of a national body of State associations comprising local clubs and individual members in districts where clubs do not exist. Even now a member of the A. A. A. can, without extra expense, obtain special information upon application to the association's Touring Board, and the mass of material which has been and is being prepared by clubs and members scattered throughout the country insures the perfection of a bureau which will increase in value and make it superior to any other source of similar information available to all autoists and at moderate cost.

The good of automobiling requires a national organization which shall be such in reality and not alone in name. Judging from the astounding progress of the Hotchkiss-Hower-Thompson-Terry-Hooper-Van Sicklen-Elliott administration, the work of the A. A. A. is only in its beginning, for even the friends and well-wishers of the organization are forced to admit that it has been somewhat erratic in getting into its high speed. Mistakes it has made, and mistakes it will make in the future, but its accomplishments will be exactly what are made possible by the support of the growing army of automobilists. It is a habit of American citizenship as a whole to let the other fellow do the work, unless the discomforts of the situation visit themselves directly upon us, and it must be said that many automobilists withhold financial as well as moral support to those working for their interests. But with over 20,000 already enrolled, and the list growing every week, the A. A. A. should have 50,000 members before the year concludes.



**THE PRACTICE OF "DOPING" A MOTOR.**

It is a matter of common knowledge that one of the practices of horse racing has been extended to automobile racing, and this is the employment of various substances to make a motor produce far more than its rated power by means which may be compared to what is known as "doping" a horse. Crude methods of doing this involved nothing more than the mixture of some powerful agent, such as picric acid, directly with the gasoline, but more recently science has been called into play and accurately measured doses of oxygen administered.

As a matter of scientific interest, such experiments are of considerable value, as they tend to demonstrate that the internal-combustion motor is far from having reached the end of its great possibilities. On the other hand, they seem to have had an unfortunate influence on many an amateur autoist, who is anxious to try the effects of picric acid, oxygen and acetylene gas for himself. No one who uses horses for his own pleasure would think of following race track practices to get a little more speed out of them, so that it seems strange that so many autoists should wish to learn how to do this to their motors.

## GEORGIA'S GOVERNOR TO PRESENT SAVANNAH TROPHIES

SAVANNAH, GA., Feb. 24.—The general executive committee of the March 18 and 19 races have arranged the program of the meet. A feature will be the presentation of the trophies by Governor Hoke Smith, who showed his interest in the races by the offer to call out the military to police the course, which offer was as promptly accepted.

The program decided includes for Tuesday, March 17, at 4 P. M., a parade of the officials in touring cars and the contesting automobiles. Wednesday, March 18, there will be the two 180-mile races. The runabout event will begin at 11 A. M. At 3 o'clock, what has been known as the "six-cylinder cup race," but to which are now to be admitted cars having a piston displacement of more than 575 cubic inches, will be started. Thursday, March 19, will be the big race for the Savannah trophy, start being at 12 o'clock.

At 8 o'clock in the evening Governor Smith will present the trophies at the De Soto Hotel. The challenge trophy will be a silver cup set upon an ebony base, the whole being 27 inches tall. The design is the workmanship of S. E. Theus. The other two prizes are the work of R. Van Keuren. These cups, while smaller than the challenge trophy, have attracted high praise. The challenge trophy is a Grecian shaped two-handled cup. An oval frame containing the picture of Oglethorpe is the central engraving. Beneath the picture is a shield with "Governor Oglethorpe" and a date upon it. Supporting the frame are palm branches and live oak covered with Spanish moss, all in bold relief. On one side of the frame is an Indian scene representing life about

Savannah in 1733. In unusual contrast is the scene on the other side of the central engraving. Here are shown automobiles of latest design at racing speed, with the date "1908." The convoluted stem of the cup has alanthus leaves in relief. The base is Corinthian. The ebony pedestal is octagonal in shape. Cotton bales surround it, affording room for the inscription of the names of the successive winners of the cup. The trophy is to cost \$1,800. Each of the cups designed by Mr. Van Keuren is to cost \$1,000.

Each of the winning drivers will be presented with a bronze medal. These will have a facsimile of the coat of arms of Savannah and a suitable inscription.

N. H. Van Sicklen, chairman of the Technical Board of the A. A. A., is expected to arrive in Savannah within the next few days to assist the local committee.

Mayor Tiedeman and the City Council have gone further than promised and declared both days holidays.

J. H. Andrews, Mineola, N. Y., of the firm which oiled the Vanderbilt Cup course on Long Island, has just left the city after inspecting the roads composing the course. He made a proposition to the committee having charge of the preparation of the roads which will probably be accepted. After looking over the course, Mr. Andrews said of it: "The course is much better than the Vanderbilt Cup course on Long Island. More than every mile of this course is better than any mile of the Vanderbilt course. They are raving about the scenery of this course up North, but the road is better than the scenery."

## SAVANNAH AND ST. LOUIS WANT VANDERBILT CUP RACE

AT the meeting of the A. A. A. Racing Board, held Monday last at the association's headquarters, 437 Fifth avenue, New York City, it developed that both Savannah, Ga., and St. Louis, Mo., are substantial seekers for the honor of supplying a course for the 1908 Vanderbilt Cup race in case it is found advisable to hold the event elsewhere than as usual on Long Island. Chairman Jefferson deMont Thompson, who presided at the session, was empowered to investigate the proposition from Georgia and Missouri.

Present at the session besides Chairman Thompson were William K. Vanderbilt, Jr., donor of the famous cup; A. R. Pardington, general manager of the Long Island Motor Parkway; S. A. Miles, general manager of the National Association of Automobile Manufacturers; Alfred Reeves, general manager of the American Motor Car Manufacturers' Association; A. L. Riker, Bridgeport; E. R. Thomas, Buffalo; H. R. Worthington, A. G. Batchelder and Secretary F. H. Elliott.

Various subjects discussed were referred to sub-committees

for disposition. The report of the rules committee, consisting of Chairman Thompson and Messrs. Miles, Riker and Reeves, occupied several hours, and it was decided to send the final draft to the board members for immediate consideration and concluding suggestions.

While nothing definite has been announced regarding the amateur definition, the rule has been thus modified:

A man who has never driven or raced a motor car for pay, either in cash or any other valuable consideration; or competed for a cash prize; who does not make his livelihood or any part of it, as a result of racing or driving, either as a demonstrator, tester, or chauffeur; who has not otherwise received financial reward for engaging in competition; who has never been declared a professional by any sport-governing body, or who, having been so declared, has been reinstated either by such body or by the A. A. A. Racing Board.

Of course, it is still possible to hold special events limited only to those specifically desired in them, but for the purpose of open competition the new rule should be found much more satisfactory than the former one.

## A. A. A. TO FIGHT NEW YORK TIRE CHAIN ORDINANCE

AFTER having thoroughly investigated the status of the ordinance recently adopted by the New York Park Board, prohibiting the use of tire chains on cars entering any of the city parks, the American Automobile Association has decided to make a test case with a view to having the ordinance declared unconstitutional, and to that effect has just issued an announcement offering to defend any of its members who may be arrested for a violation of the said ordinance. The announcement will be interesting to autoists of other cities, where similar ordinances may be attempted.

To Members of the American Automobile Association:

Any member of the American Automobile Association arrested for alleged violation of the recently re-enacted ordinance by the Park Board of the City of New York, prohibiting automobiles wearing tire chains, upon due notification to the office of the Association, 437 Fifth avenue, or to Charles Thaddeus Terry, Counsel for the American Automobile Association, 100 Broadway, New York, by person so arrested, the Association will be willing to defend the person or persons so arrested, without expense to him or them, in such a number of cases as may be adequate to test the validity and frugality of such ordinance.

F. H. ELLIOTT, Secretary.



### AGENCY SUIT DECIDED AGAINST A. L. A. M.

In the action brought by the Association of Licensed Automobile Manufacturers to punish Walter C. Allen for contempt for having disobeyed an injunction obtained against him some time ago, Judge Holt, sitting in the U. S. Circuit Court for the Southern District of New York, has just decided in favor of the defendant. Mr. Allen was associated with the Dietrich Import Company, and is now one of the builders of the Allen-Kingston car. When he gave up his Dietrich "Licensed" connection and undertook the sale of the Allen-Kingston car, it was a violation of his agency agreement, according to the Licensed Association, which promptly obtained an injunction against him. Mr. Allen did not defend the application for an injunction, nor did he pay any attention to it when obtained, for which reason the association made a motion to have him punished for contempt of court. Judge Holt reviewed the situation at length, and his decision, though on an entirely collateral issue, is considered of importance in Selden matters. He said in part:

If, therefore, the Allen-Kingston automobile is obviously, upon mere inspection, an infringement of the Selden patent, the motion to punish him for contempt in offering to sell it should be granted. The question whether it is obviously an infringement seems to me to depend upon the question whether the Selden patent is a pioneer patent or not.

If the Selden patent conveyed to the patentee a monopoly, in this country, of the right to make and sell any gasoline automobile of the usual types, then I think that the points of distinction alleged in the affidavit of Mr. Smith are immaterial, but if the Selden patent is not a pioneer patent covering the entire fundamental principle of the gasoline automobile, but simply is a patent for a particular kind of a gasoline automobile, I think it at least doubtful, in view of the grounds of distinction pointed out by Mr. Smith, whether the Allen-Kingston automobile infringes.

It is claimed that the opinion of Judge Coxe shows that he held the Selden patent to be a pioneer patent, and its language, at first reading, seems to tend to sustain that claim; but I think that the opinion of Judge Coxe should be read in the light of the real question before him, and I cannot see how the question of the absolute validity or invalidity of a patent can be determined upon a demurrer which is based simply upon the claim that the patent is void on its face. If the patent shows on its face that it is void, that fact may be determined upon a demurrer; but it seems to me that a decision upon such a demurrer upholding a patent cannot be conclusive on any defense which depends on extraneous proof, as, for instance, anticipation by earlier patents, or by inventions described in earlier publications, or by prior use, or any of the many defenses which may be set up to the validity of a patent which are not apparent on its face. I therefore cannot see how the decision of Judge Coxe upon the demurrer establishes conclusively that this patent is either a pioneer patent, or is valid, and admittedly there has been no decision rendered after a hearing upon the merits on proofs taken. Moreover, there are facts in this case which support the suggestion that the complainants have hesitated to bring such a question to actual decision.

The patent was applied for in 1879. It was granted sixteen years later, in 1895. Nearly thirteen years have since passed, during which the complainants have asserted that they had a pioneer patent, and have caused many persons to take out licenses from them, and have collected, according to the motion papers, about \$1,500,000 for license fees, without bringing to actual trial a case testing the question of the validity of this patent on the merits. Several such cases have been brought. One was a case against the Winton Carriage Company, in which the complainants took their prima facie proofs, and the defendant had nearly completed its proofs, when the case was compromised, and settled out of court. As early as 1903 suits were brought by the complainants against the Ford Motor Company and the O. J. Gude Company, for the infringement of the Selden patent, and as early as 1906 suits were brought by the complainants against the Panhard Company. In all these suits defenses were interposed on the merits, but the testimony never has been completed, and the cases never brought to a hearing.

The claim put forth upon this motion is that the Selden patent is a pioneer patent, and that all makers of gasoline automobiles of the usual types infringe the patent. So serious a claim as this ought not to be upheld by the courts unless the complainants either have established the validity of the patents in a contested litigation, or have been ready to do so without delay whenever an opportunity has been offered.

If this motion is granted, it will be urged, as the decision of Judge Coxe on the demurrer has been urged, as an adjudication that the Selden patent is a pioneer patent, and that all makers of

gasoline automobiles must have a license. I think, on the papers submitted, that there is sufficient doubt whether the Selden patent is a pioneer patent, and that, if it is not a pioneer patent, there is sufficient doubt whether the Allen-Kingston automobile infringes, to make it improper to grant this motion.

My conclusion, therefore, is that the motion to punish the defendants for contempt should be denied.

February 15, 1908.

The counsel for the Association of Licensed Automobile Manufacturers were Betts, Sheffield, Bentley and Betts (Samuel R. Betts, William A. Redding), and James J. Cosgrove, of counsel, while the lawyers for the defendants were the firm of Nathan Bijur and George H. Engelhard, with R. A. Parker, of counsel.

### ALBANY'S AUTO LEGISLATIVE GRIST.

ALBANY, N. Y., Feb. 24.—During the past week motor vehicle legislation was one of the foremost topics considered by the legislators. There was a hearing before the general laws committee on all the bills before that committee, at which Attorney Charles T. Terry appeared for the A. A. A. Legislative Board, and Attorney M. Bender of Albany for the State association. They argued against the Donihee bill to require a special form of auto lamp which should be so shaded as to prevent the escape of any upward rays and against the Northrup bill to tax auto owners \$5 each as a sort of road tax in addition to the registration fee. Neither bill was reported.

But the Weimert bill, to give garage keepers a lien on motor vehicles cared for when the owners fail to pay bills for keep, repairs, or supplies, was not objected to and, after being perfected by a slight amendment to include gasoline in the supplies, was reported for reprinting and to take its place on second reading.

The Wainwright bill, authorizing boards of supervisors to enact laws requiring all vehicles using the highways at nights to display lights, if not already so required by other laws, will be given a hearing Tuesday by the Assembly internal affairs committee.

Other bills introduced are the Eagleton bill, to prohibit the use of any motor vehicle of more than 20 horsepower for other than speed tests and races; Eagleton's bill to give persons injured by a motor vehicle a lien on the vehicle for the amount of the judgment secured by reason of such injury; the A. E. Smith bill, to tax motor vehicles according to their seating capacities, and Senator Grady's bill, for the protection of persons on highways, which seeks to provide that "All lawfully disposed persons have an equal right to be upon, use and traverse the public highways, roads, streets, avenues and places in this State, and no person has a right to drive or ride thereon at a rate of speed dangerous to others.

There will be a hearing on Wednesday of this week before the Assembly general laws committee on the Yale bill to repeal that section of the motor vehicle law which now permits supervisors and other local authorities to set aside a portion of the highway for auto races. Attorney Terry was ready to argue on the bill last week, but Mr. Yale had arranged to put it over a week, and said then he would bring up a delegation to favor the bill. It is understood that a delegation of Long Islanders, headed by Congressman Cocks, will appear to favor it, with certain persons from Westchester and Putnam counties.

### MARCH MEETING OF THE A. S. M. E.

The March meeting of the American Society of Mechanical Engineers will be held on Tuesday evening, March 10, in the Engineering Societies building. The meeting will be addressed by Dr. Charles P. Steinmetz, who is a member of the A. S. M. E. and a past president of the American Institute of Electrical Engineers. His subject will be "The Steam Path of the Steam Turbine."

## NEW JERSEY IS HAVING A SUCCESSFUL SHOW

NEWARK, N. J., Feb. 26.—Though so crowded for space that almost every dealer was reduced to exhibiting but one model of any make, Newark's first automobile show in the Electric Park auditorium had all the features that make for popularity and success. When Mayor Haussling, of Newark, and Mayor Shoenthal, of Orange, pronounced the

tomobilists and leaders of the clubs and associations in the New Jersey and the Metropolitan district. Though many of the clubmen arrived in their own automobiles from distant points, there was no difficulty in housing the cars, the grounds surrounding the auditorium forming an excellent open-air garage. Society is to have its exclusive innings Thursday night.

As a stimulator of interest in automobiling and an aid to spring buying, the Newark eight-day show came up to all expectations. Between the few who thought the venture too modest and the still smaller number deprecating any exhibition, there was a solid group of dealers who realized that a late winter show would help along spring sales and stimulate activity generally, and they were in no way disappointed.

Prominent among the inside attractions is a cinematograph exhibition every evening at 9 o'clock, the moving pictures representing Vanderbilt Cup races and other automobile events being shown on a screen let down in the center of the hall and visible from both sides. A musical program is given afternoon and evening of each day.

As a convenience to residents in the Oranges and at the same time as an automobile demonstration,

twelve White steamers carry passengers to the Electric Park at intervals of half an hour, from 2 to 11 P. M. Their starting points are the Brick Church and East Orange stations of the Lackawanna, and from Main and Day streets, Orange.

Thirty-one different makes of automobiles are exhibited by twenty-two dealers, the number of cars on exhibition being about fifty. In addition a full line of accessories are shown by all the more prominent local dealers. The car exhibitors



ELECTRIC PARK AUDITORIUM, WHERE NEWARK HELD ITS FIRST AUTO SHOW.

official opening speeches on Friday evening, February 21, the auditorium was a tastefully decorated hall of white and gold, with every car in its place and so crowded with spectators as to prove conclusively that the New Jersey Automobile and Motor Club and the New Jersey Automobile Trade Association would have been justified in securing a larger hall had one been available. Mayor Cardwell, of East Orange, who had arranged to be present at the opening ceremony, missed the White steamer sent to bring him to the auditorium, with the result that he was compelled to board the trolley car and enter the hall later in the evening. At that time the crowd was so great that the management had serious thoughts of closing the doors. In addition to the three mayors, a strong force of city officials and prominent automobilists attended on the opening night, the total attendance for that evening being 5,000, according to official figures. Though slightly less on the succeeding evenings, there was never anything approaching a dearth of visitors, and according to the reports of exhibiting dealers business is always of a satisfactory nature.

Tuesday evening being "Club night," delegations from Englewood, Paterson, New Brunswick, Plainfield, Trenton, Camden, Cape May, Jersey City and other points filled the hall with well-known au-



HOW THE CARS WERE STAGED IN A SETTING OF WHITE, GOLD AND NATIONAL FLAGS.

include practically all the important dealers of Newark and district, and are in quite a number of cases supported by some part of the staff from the factories they represent. The cars range from modest single-cylinder doctors' runabouts and equally modest buggyabouts to handsome six-cylinder automobiles with limousine body. The complete list of car exhibitors, with the cars they are showing, is as follows:

EXHIBITOR.	CAR.
A. G. Spalding & Bros.	Stevens-Duryea
Allen-Kingston Motor Car Co.	Allen-Kingston
Brush-McLaren Motor Co.	Brush and F. N. Motorcycle
Calvert-Zuel Co.	Winton
Carl Page Co.	Peerless
Chas. S. Cooper	Atlas
Ellis Motor Car Co.	Pierce Great Arrow and Knox
Essex Auto Co.	Jackson
Garford Motor Car Co.	Garford
Greene Motor Car Co.	Locomobile, Oldsmobile
H. J. Koehler	Buick and Waltham
Hygrade Motor Car Co.	Ford
J. W. Mason	Maxwell and Stoddard-Dayton
Mitchell Auto Co. of N. J.	Mitchell
Motor Car Co. of N. J.	Packard, Autocar, Cadillac, Northern
Osborne & Morton	Auburn
P. H. Johnston	Grout
Rickey Machine Co.	Marmon
Sheldon W. Case	Holsman
Star Motor Car Co.	Pullman and Napier
The White Company	White
W. S. Maltby	Corbin

The "New Jersey Automobile Exhibition" is the name of the definite company under whose auspices the show is being held, its make-up containing President Angus Sinclair, Secretary H. A. Bonnell, and ex-Presidents Joseph H. Wood and James R. English, of the Automobile Club, and R. A. Greene, J. W. Mason, and W. H. Ellis, from the Trade Association, with George Paddock, president of the Trade Association, also being president of the company. W. F. Kimber is legal adviser.

### FRANKLIN MAKES A WINTER RECORD.

CINCINNATI, Feb. 24.—An eleven-day run over Ohio and Kentucky roads under rigorous non-stop conditions would be a creditable performance under any circumstances, but to demonstrate that the Franklin air-cooled car was equal to any conditions, no matter how bad, the Sid Black Automobile Company, Franklin agents in this city, started a Franklin 28-horsepower Model D car on a non-stop, mileage and economy test on February 11. On that day and the two following the car made successive trips to Columbus and return, the state of the roads being almost inconceivable as it was then at the close of a week's rain. Trips were also made to Lexington and Hamilton, Ky., during the most severe winter weather. Sid Black, C. A. Robinson, John Burns and V. Higgins took turns at the wheel, each handling the car for a six-hour shift, while two observers were carried at all times. At the conclusion of the test the engine had been running constantly for 11 days, or 264 hours, during which time the car had covered 2,152 miles.

### N. Y. AUTO RACING OPPOSITION EXPIRES.

ALBANY, N. Y., Feb. 26.—The Yale bill to repeal the section of the Motor Vehicle law permitting road races is dead. The hearing to-day was adjourned indefinitely by the general laws committee. Charles T. Terry, A. R. Pardington, F. H. Elliott, M. T. Bender, O. A. Quayle and C. D. Hakes, of the American Automobile Association, were present to oppose the measure. Assemblyman Yale will abandon his bill.

The Bashford bill before the committee, amending the automobile law generally, is also dead.

The delegation here to-day also appeared before the codes committee in opposition to the McGrath bill to compel motorists to stop and wait to be arrested or be guilty of a misdemeanor.

### A. A. A. DOES SAME WORK AT LOWER PRICE.

In view of the fact that clubs belonging to the A. A. A. only pay \$1 per year per member, of which 75 cents goes to the State association and only 25 cents to the national body, and the annual fee for non-club members is only \$2, it would seem that automobilists generally will continue to obtain their touring information, books, maps, etc., from the A. A. A. rather than make any grand rush to become "subscribers" of the bureau of tours of the A. C. A. at \$10 per year. This is the comment of Arthur N. Jervis in the *New York Mail*:

"Considerable curiosity is cropping up as to the motive behind the new plan of the Automobile Club of America, which has just been announced. Although it is said that the club has no thought at present of forming a separate association, the decision to organize a floating membership into a sort of loosely affiliated or supplementary body on the lines of the Touring Club of France has suggested to some that the A. C. A. plans an organization to obtain, classify and dispense touring information after the methods in vogue in Europe. Such a body would necessarily be a rival in the field to the American Automobile Association, which now does this for its members, and at a much lower cost for membership than the \$10 a year which the A. C. A. proposes to charge the subscribers to its 'bureau of tours.'

"The A. A. A. has a touring board that dispenses information about tours here or abroad free to its members. This work has been growing rapidly, and is now one of the most important branches of A. A. A. activity. It would take a long time for any other body to get a touring bureau organized in the fine working order that the A. A. A. has its department. The A. A. A. has the recognition of the foreign organizations, as well as the A. C. A., but a rivalry between the two would not contribute to the prestige of American automobilists going abroad."

### SCRANTON WILL ENFORCE LAW ON SIGNS.

SCRANTON, PA., Feb. 24.—Through its attorney, Hugh B. Andrews, the Automobile Association of Scranton has served notice on the road supervisors and constables of Lackawanna county that the law dealing with sign boards and loose stones must be rigorously enforced. Under the act of June 18, 1886, the supervisors are compelled to erect sign posts at the intersection of all public roads within their respective townships, the penalty for neglect or refusal to do so after ten days' personal notice being \$20 in each case. Under the act of July 2, 1901, Township supervisors and road commissioners are responsible for the removal of loose stones from the highways at least once a month during May, June, August and October. Penalty for neglect or refusal to carry out the provision of the act is \$10, to be recovered by action of debt in the name of the Commonwealth.

### FIRE WILL NOT DELAY STODDARD-DAYTON.

DAYTON, O., Feb. 26.—Last Friday morning, February 21, a destructive fire broke out in the trimming room of the Dayton Motor Car Company's big plant. The fourth floor of the new six-story concrete building was gutted, the fourth and fifth floors of the office building entirely destroyed, and the first three floors of the same building soaked with water.

When the fire had been subdued so that the fire department could control it, H. J. Edwards, chief engineer of the concern, with R. T. Houk, superintendent of the plant, were busy planning for the work of the morning. The moment the water was shut off, an army of workmen started the work of clearing away the debris, and while the fire engines were still on the scene letters were going out to the agents telling them to be of good cheer. J. W. Stoddard, president of the company, who does not know the meaning of the word defeat, was on the scene early and personally directed the reorganization and went home only after having given his instructions to the different departments.

On Monday morning, forty-eight hours after the fire, every man of the force was back at his work. Men who do things surround J. W. and C. G. Stoddard.

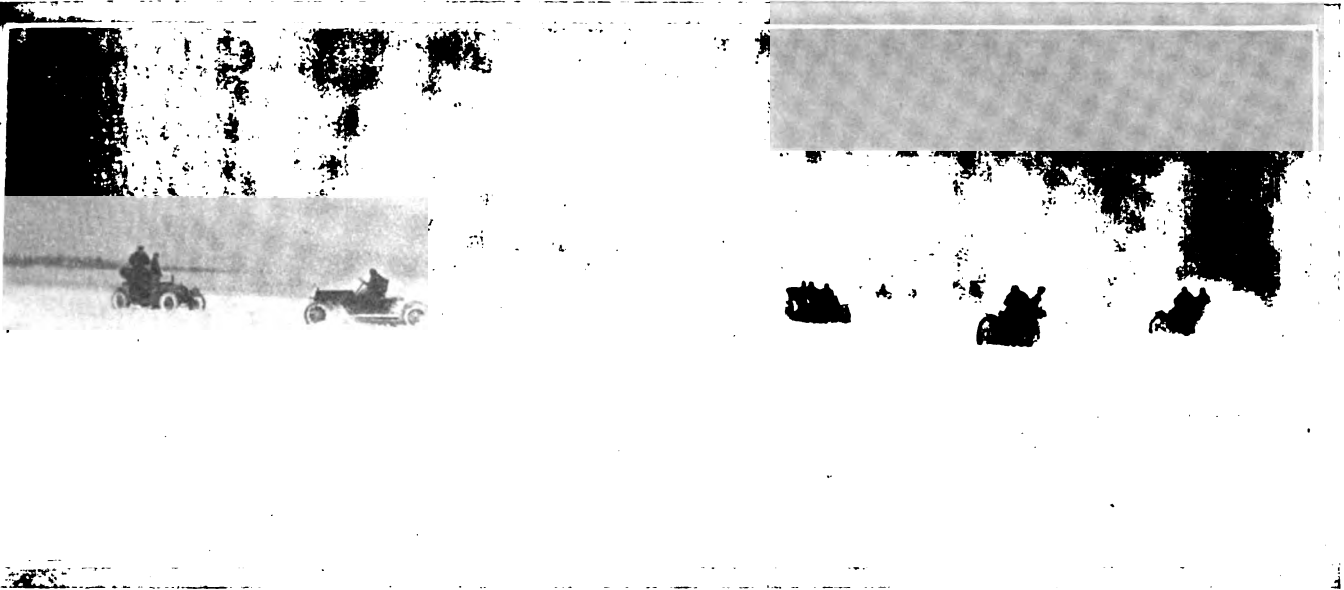

PACKARD TESTERS UTILIZING THE ICE-COVERED SURFACE OF LAKE ST. CLAIR—TURNING POINT IN IMPROMPTU RACE.

### CAR TESTING ON SNOW-BLANKETED ST. CLAIR.

DETROIT, Feb. 24.—While the ice boats lay buried and frozen in the deep snow which covered Lake St. Clair from shore to shore and Detroit was snowbound, with its suburban traffic halted, limited passenger trains being dug out of drifts and freight trains abandoned, a dozen automobiles last week raced and chased through the unbroken drifts on the broad sheet of ice. As black specks on the horizon swept toward the shore, throwing a great cloud of snow high behind them, they became recognizable as a squadron of "Wild Bill" Birmingham's army of Packard testers, while the gray run-about, racing with Sales Manager Waldron's touring car, was piloted by Manager Joy. The Packard Motor Car Company had been for weeks using the old-fashioned winter to advantage in the testing of cars through snowdrifts and up and down icy, snow-shrouded hillsides. The administration, engineering and testing departments had been busy for days driving cars through the snow-clogged thoroughfares leading out of Detroit. The last heavy storm spread a thick blanket over the lake and made it an ideal place for fast running over a broken track, for plugging through drifts and for general and unhindered wintertime testing. Hence the immediate inauguration of Lake St. Clair as a new testing rendezvous by the Packard folks. The lake is so solidly frozen that it is possible to drive all over it, although on account of snow-covered cracks it is not safe to drive from shore to shore without a local guide who is familiar with the location of the dangerous places. The photograph shows an impromptu race between the testers at the point where one of the turns is made.

### PACKARD MAY ACQUIRE HARTFORD PLANT.

HARTFORD, CONN., Feb. 24.—It is reported in automobile circles in this city that there is a likelihood of the plant of the defunct Electric Vehicle Company being acquired by the Packard Motor Car Company of Detroit. It is a matter of common knowledge that the sales of Packard cars in the East are very large, and it is rumored that the object of the company in taking over the plant in question would be to establish an Eastern department. It is also well known that the Packard Company suffered less during the recent financial stringency than the majority of its competitors and that it is in an excellent position to finance the acquisition of the Hartford plant, should this be deemed advisable. On this account the report is receiving considerable credence here.

### RAPID COMPANY DECLARES DIVIDEND.

PONTIAC, MICH., Feb. 24.—That the automobile industry did not suffer to as great an extent as many of its detractors would have the world believe, is evident by the fact that the Rapid Motor Vehicle Company, of this city, has just declared a 10 per cent. dividend on its stock, having had a most prosperous year during 1907. The officers of the company are A. G. North, president; Max Grabowsky, vice-president; H. G. Hamilton, treasurer and manager, and Morris Grabowsky, secretary. All are confident that the coming twelvemonth will see a volume of business fully equal to, if not greater than, that of the past year. Orders are plentiful at the factory and a full quota of help is employed.

### TIRE PRIZES FOR BRIARCLIFF DRIVERS.

Further stimulus to effort on the part of the drivers who will take part in the Briarcliff Trophy race, is to be found in the recently announced offer of the Diamond Rubber Company, of cash prizes for winners on cars equipped with Diamond tires. For the first, \$500 is offered; second, \$350, and third, \$150. The specially trained tire crews of the Diamond company will be stationed along the course and will give their entire attention to the competing machines that are equipped with Diamond tires.



CADILLAC MODEL G AS MOTIVE POWER FOR SNOW PLOWS.



## BRIEF ITEMS OF NEWS AND TRADE MISCELLANY

The Hume Carriage Company, which was established in Amesbury, Mass., in 1857, and which makes a specialty of building high-grade limousine, landaulette, touring and runabout bodies, demi-limousine and cape tops, has removed its entire factory to 66 Stanhope street, Boston.

The official record of automobiles registered in New York State for the months of October, November and December, 1907, shows that the Renault leads all the rest of the foreign makes. During these three months more Renault cars were registered than the five next highest foreign cars combined. For the week ending February 8 more Renault cars were registered in New York State than all other foreign cars put together.

The Ormond-Daytona (Fla.) race meet, to be held the first week in March, is receiving generous support from the Continental Caoutchouc Company, makers of Continental tires. One of the prizes offered is \$200 in cash to the owner of the automobile winning the 300-mile race, provided, of course, the car is equipped with Continentals. Another offer relates to the 100-mile event, for which a special prize of \$100 is offered to the owner of the winning car, under the same conditions.

Everybody interested in the actual cost of running a high-grade car will have facts and figures to guide them when the Winton Company publishes the result of its \$2,500 contest for Six-Teen-Six drivers. The rules of the contest require monthly reports from all contestants and the figures are being compiled for public distribution as soon as the awards are announced. Any employed driver of a Six-Teen-Six is eligible to enter the contest. There are ten individual prizes ranging from \$100 up to \$1,000 in gold coin.

An increase in the sale of commercial vehicles is noticed throughout the country. The use of these motor cars is being extended and the manufacturers are looking for good business in this line. The H. H. Franklin Manufacturing Company delivered last week a 16-horsepower one-and-a-half ton truck to Philadelphia and one to Easton, Pa., and has orders for immediate delivery from Memphis, Tenn., New York, Denver and other points. The Model J Franklin trucks, which are constructed along the Franklin lines of light weight and air-cooling, each do the work of three horses at the Franklin factory.

Jason Silve, who drives the mammoth Warner autometer about the country, showing up the absurdity of the speed laws, started from Chicago for the Warner factory in Beloit, Wis., during the recent February blizzard. When he got as far as Elgin, Ill., he was compelled to stop and turn around. Time after time he was forced to get out and prop the huge instrument to prevent it from toppling over. This was rendered necessary from the fact that the instrument is 9 feet 6 inches in height and weighs 800 pounds, with the weight mostly at the top. The big autometer will be completely overhauled when it arrives at the factory, and will be ready for its second summer of touring.

Gabriel horns are finding favor with the crowned heads of Europe. Brown Brothers, the European agents, have recently sold one to Alfonso XIII., King of Spain,

for use on the royal auto, and a Gabriel has also found its way into the imperial garage at Berlin, where it graces one of the cars of the Emperor William. It was the birthday gift of his brother, Prince Henry of Prussia. The Emperor has ordered two more of his cars to be equipped with Gabriels. King Edward of England has had a Gabriel on his car for a couple of years, and the Czar of Russia has recently purchased one, as has also Dowager Queen Margherita of Italy. The inventor of the horn, C. H. Foster, has recently invented a shock absorber and given it the name of Gabriel.

A. L. Kull, sales manager and vice-president of the Dragon Motor Company, has returned from a Western trip to New York City and will remain there for a week or two before removing to Philadelphia for the spring. Mr. Kull states that he found trade improving in the West and a general feeling of hopefulness among manufacturers and dealers. One of the noticeable features was the demand in all the Western cities for taxicabs. There is a decided trend toward adopting the taxicab for street use in all American cities of any note, says Mr. Kull, and it appeared to him that it would be several years before this demand could be satisfied, no matter how industriously the various manufacturers now in the cab business worked at the task.

The Archer, Combs & Winter Company is the title of a newly organized corporation which has recently begun business in Portland, Ore., its headquarters being located at 306 Oak street. The officers are P. A. Combs, president and treasurer; A. J. Winters, vice-president, and Samuel B. Archer, secretary. The capital stock is \$20,000, fully paid in, and the corporation will make a specialty of handling automobile accessories, fishing tackle and sporting goods, doing a jobbing business entirely. The members of the new firm have a wide experience in these lines in Oregon, Washington and Idaho, having been identified with selling goods of this class at wholesale for a number of years. They control a number of specialties for the above territory as manufacturers' agents.

"We don't need a snow plow," said E. R. Thomas when asked as to the practicability of fitting a rotary plow to the front of America's defender in the big race. "Only in extreme cases is it necessary to use outside means to get the car through. Recently we ran a Flyer through from Buffalo to Boston, through the Berkshires, through snowstorms, snow drifts, ice and mud, and only twice resorted to shovels. Each time a very little work, merely clearing away the snow which had packed in front of the car, was sufficient. There is no doubt that a successful rotary snow plow could be designed by our engineers and the power of the motor is much more than sufficient to drive such an apparatus in addition to propelling the car. Such an arrangement might be of great service in extreme cases, but its service at such a time would not offset the disadvantage of carrying it when not needed. It is only in extreme cases that such an arrangement would be used, and we firmly believe that the Thomas Flyer is fully capable of overcoming all but most extraordinary conditions found on American roads."

### NEW AGENCIES ESTABLISHED.

Cimiotti Brothers, 1843 Broadway, have taken up the sale of the York Pullman automobiles for the territory of Greater New York, Long Island and Westchester county.

J. H. Rogers, late of the Diamond Rubber Company, Chicago, and W. H. Roesch, formerly of Dawson Brothers, that city, have formed a partnership and taken the agency for the Wisconsin tire protector, manufactured by the Tire Protector Company, of Stevens Point, Wis. Their new offices are located at 1229 Michigan avenue, Chicago.

The Babcock Electric Carriage Company has met with such success with its New York branch, established last November, that it has decided to establish a branch in Chicago, which is located at 1328-1330 Michigan avenue, in the heart of the automobile trade district. C. M. Atterbury has been appointed manager.

### PERSONAL TRADE MENTION.

B. F. Blaney has just been appointed sales manager of the Selden Motor Car Company, Rochester, N. Y., and has entered upon his duties of placing the Selden agencies. This duty previously devolved upon the designer of the car, E. T. Birdsall.

E. Le Roy Pelletier, the well-known publicity and advertising manager, is now doing Italy, but will sail from Naples the latter part of this week homeward bound. He returns to take charge of Maxwell publicity, with headquarters in New York City.

W. H. Cameron has been appointed manager of the repair department of the Gibson Automobile Company, Indianapolis, Ind., who handle the Ford, Premier and Reo lines, and will conduct that part of the business under the name of the Automobile and Tire Repair Company.

Owing to the resignation of Mr. vanderhoff, as manager of the Philadelphia branch of the Ford Motor Company, Louis Block, who has been in charge of the Buffalo branch, will transfer his headquarters to the Quaker City, while Roger Stearns, who has been acting as assistant to Gaston Plaintiff, of the New York branch, will take charge at Buffalo.

### NEW TRADE PUBLICATIONS.

A house organ is now produced by the Autocar Company, Ardmore, Pa., under the title *Autocar Life*. Its object is to keep Autocar owners informed of doings in their own particular world, and, to judge by the style of the special show number just to hand, this is thoroughly attained.

Bridge whist and automobiling are combined in the publication by the Peerless Motor Car Company, Cleveland, O., of a bridge whist score book, on the heading of each page of which is a scene on the highway when touring in a Peerless. At the end individual scores are forwarded and rules for playing whist are given in full. The idea is an excellent one, and the publication should be a success. Automobilists can obtain copies on request at the headquarters of the company.

**INFORMATION FOR AUTO USERS**

**New Tooth-Chamfering Attachment.**—Chamfering of the spur gear teeth of the pinions of an automobile gear-set may appear to be a matter of minor importance, but it is one of those little things that have contributed to make the automobile a success. Automobile manufacture nowadays is made up almost entirely of details, and success in this field is coming to be more

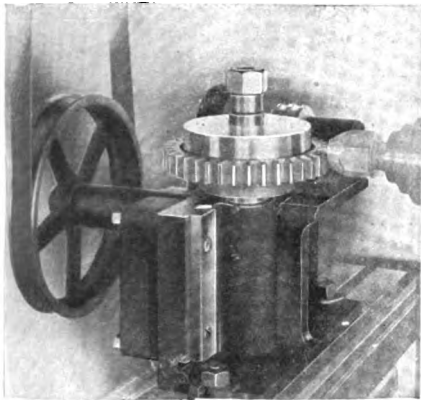

LONG-ARM TOOTH-CHAMFERING ATTACHMENT.

and more a question of economy in carrying out these multitudinous details of construction in a first-class manner. This is where the value of special machine tools and attachments such as that shown here, which has just been perfected by the Long Arm System Company, Cleveland, O., contribute to successful automobile building. The Automatic Tooth-Chamfering attachment does the work more uniformly and in better shape than it is possible to do it by hand, or by any of the make-shift devices adopted in many shops. It also does the work more rapidly, and that means economy.

**Wico Roller Timer.**—One of the latest specialties added to its line of ignition apparatus by the Witherbee Igniter Company, 541 West Forty-third street, New York City, is known as the Wico Ring and Roller Timer, Wico being the trade

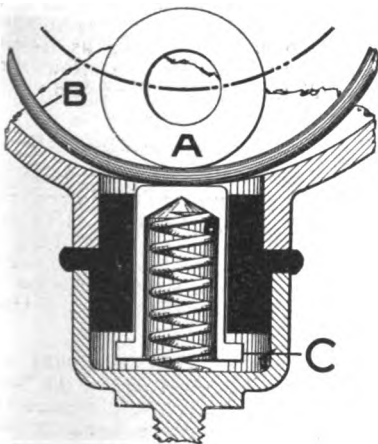

DETAILS OF WICO ROLLER TIMER.

name under which this concern puts out all its ignition specialties, with the exception of the well-known Witherbee Igniter, or storage battery. It is constructed on a novel principle, consisting of a loose ring, which is rolled upon the different contact

points as it revolves. The difference between the diameter of this loose ring and its containing case in which it rolls is such as to assure a constantly changing point of contact for the action of the current, the slight abrasion consequent upon this action and its impact being thus distributed over a comparatively large area. When rolled upon a contact point this ring acts as a direct conductor for the current into the case proper, bridging a gap of about 1-4 inch and reducing the resistance to practically nothing. It also distributes the effect of the resulting arc over its entire periphery. This loose ring consequently takes practically all the mechanical wear from the roller inside, and the action of the current outside, over an area much greater than the combined areas of similar surfaces on the usual type of timer. It may be replaced at nominal cost in a few minutes. The tool-steel contacts are hollow and contain a bronze spring, holding them uniformly in position. They are contained in a fiber tube extending nearly through the case, so that the ring cannot come in contact with the insulation.

**McCanna Multiple Pump Oiler.**—Lubricators of this type have many advantages, as the accidental derangement of any one of the pumps does not interfere with the working of others and conse-

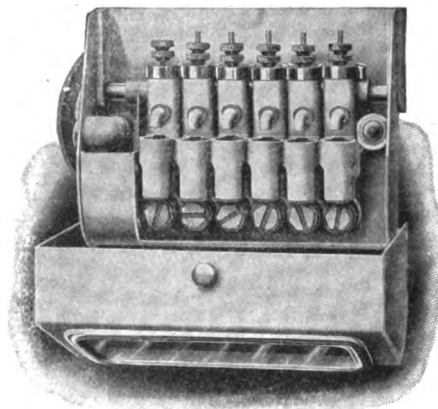

M'CANNA MULTIPLE PUMP OILER, CASE REMOVED

quently the supply to the remaining bearings goes on unimpeded. Each pump may be adjusted to deliver a different quantity of oil according to the bearing it is feeding, and any one of the pumps may be operated by hand at any time without changing the adjustment. A single pipe leads from the reservoir to the pumps, with a direct pipe from each pump to the point to be lubricated, the pumps themselves being constructed on approved hydraulic principles, thus insuring long and reliable service. The oil tank may be placed at any easily accessible point under the hood, body or seats, thus removing this encumbrance from the dash and keeping the floor boards clean. Kerosene

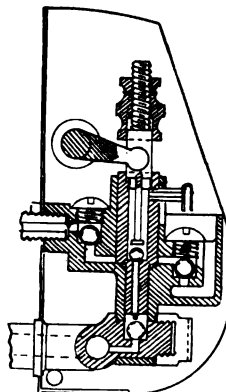

M'CANNA PUMP.

may be fed to any point desired and in any quantity, merely by putting in the sight feed chamber of the respective pump, thus making it possible to flush out any of the leads without taking down anything. A small electric light is provided to show the oil feeds at night. These multiple pump oiling systems are made in any number of leads from one to twelve for automobile use by the McCanna Manufacturing Co., 56 N. Jefferson street, Chicago.

**Breech-Block Clip Handle.**—One of the new features of the Breech Block spark plug, manufactured by the Standard Company, Torrington, Conn., is the terminal clip handle shown by the accom-

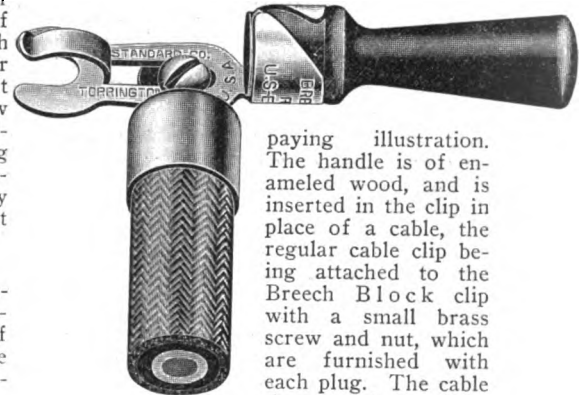

BREECH-BLOCK CLIP HANDLE.

panying illustration. The handle is of enameled wood, and is inserted in the clip in place of a cable, the regular cable clip being attached to the Breech Block clip with a small brass screw and nut, which are furnished with each plug. The cable thus attached to the clip at right angles renders the clip easily removable from the plug, as the cable, instead of being pulled against itself, acts as a hinge. The handle is an insulator, and is very convenient for ignition testing purposes.

**Raybestos Brake Lining.**—To meet the demand for a brake lining combining great wearing qualities and high heat-resisting power to stand constant application on long hills, the Royal Equipment Company, Bridgeport, Conn., has recently placed on the market a new brand of brake lining known as the "Raybestos." It is composed of asbestos woven with wire, and subjected to a special treatment, from which it obtains its adhesive qualities. It is claimed by the makers to have an unlimited wearing life, while no amount of heat can affect it. This company was one of the first to place a brake lining on the market, their "Stability" brand being well-known for several years past. It consists of a closely woven duck given a special treatment, securing adhesive and wearing qualities. It has a life of more than 10,000 miles' running, and is suitable for both light and heavy cars when not used constantly on stiff and long grades.

**Auto-Top Gloss.**—This is an elastic preparation for preserving and restoring the natural luster and finish of automobile and carriage tops, seats, guards, straps and the like, whether made of leather, Pantasote, rubber or similar material. It is manufactured by the James W. Cummer Company, 2901 East Thirty-fourth street, Cleveland, O., and is easily and quickly applied. The makers guarantee it not to crack or peel off, and one gallon is sufficient to restore and keep in first-class condition for an entire season all the accessories of this nature to be found on a car. As the average autoist allows his car to stand for long periods with the top folded, this treatment is very necessary for the preservation of the leather.

**INDEX  
TO ADVERTISERS**

Acetylene Gas Illuminating Co. 61	Cullman Wheel Co. 66	Kent Mfg. Works, A. 67	Quinby Co., J. M. 63
Acme Motor Car Co. 64	Cummer Co., Jas. W. 73	Kimball Tire Case Co. 68	Raimes & Co. 63
Adams Co. 64	De Luxe Motor Car Co. 64	King Top Mfg. Co. 68	Rainier Co. 65
Add-Wear Auto Tire Sleeve Co. 65	Diamond Chain & Mfg. Co. 66	Kinsey Mfg. Co. 68	Rajah Auto Supply Co. 68
Aerocar Motor Co. 64	Diamond Rubber Co. 101	Kissell Motor Car Co. 64	Randall-Falchney Co. 85
Ajax-Grieb Rubber Co. 92	Dietz Co., R. E. 69	Konigslow, Otto 66	Reeves Pulley Co. 69
Almy Water Tube Boiler Co. 60	Dixon Crucible Co., Joseph. 68	Lansing-Mahon Press 86	Remy Electric Co. 61
American Ball Bearing Co. 85	Dorris Motor Co. 88	Lavalette & Co. 61	Renault Frères Cover
Am. Brass & Alum. Works. 66	Dover Co., Geo. W. 59	Lavigne Mfg. Co. 63	Republic Rubber Co. Cover
Amer. Motor Car Sales Co. 104	Dow Portable Electric Co. 61	Lear Automobile Co., Oscar. 64	Richardson Engineering Co. 70
American Motor Truck Co. 88	Duff Mfg. Co. 63	Leather Tire Goods Co. 65	Robert Instrument Co. 60
Anderson Forge & Machine Co. 66	Echo Horn Co. 86	Limousine Carriage Mfg. Co. 63	Ross Gear & Tool Co. 66
Apperson Bros. Automobile Co. 93	Eclipse Machine Co. 60	Lipman Mfg. Co. 60	Royal Equipment Co. 65-67
Ashabula Bow Socket Co. 63	Eco Mfg. Co. 90	Lobe Pump Co. 66	Rushmore Dynamo Works. 100
Ashoton Valve Co. 72	Edgar Mfg. Co. 60	Locke & Co. 85	Sallsbury Wheel & Mfg. Co. 60
Atlas Motor Car Co. 64	Edmunds & Jones Mfg. Co. 60	Lockwood Bros. 67	Samson Leather Tire Co. 65
Auburn Automobile Co. 64	Eldredge Electric Mfg. Co. 67	Locomobile Co. 64	Sanford Mfg. Co., F. C. 66
Audel & Co., Theo. 72	Elite Mfg. Co. 65	Logan Construction Co. 64	Saxon Lamp Co. 81
Aurora Motor Works. 97	Ellsworth, J. M. 103	London Auto Supply Co. 63	Seaboard Florida Limited. 78
Austin Automobile Co. 71	Elmore Mfg. Co. 101	Long Mfg. Co. 84	Selden Motor Vehicle Co. 94
Auto Pump Co. 68	Empire Automobile Tire Co. 68	McCord & Co. 71	Shaler Co., C. A. 70
Auto & Supply Co. 65	Excelsior Supply Co. 71	Maja Co. Cover	Shawver Co. 61
Autocar Co. 100	Firestone Tire & Rubber Co. 65	Manhattan Electrical Sup. Co. 60	Smith Co., A. O. 69
Autocar Equipment Co. 93	Flsk Rubber Co. 87	Manhattan Storage Co. 61	Smith Mfg. Co., R. H. 83
Automobile Supply Co. 60	Forest City Motor Car Co. 97	Masury & Son, John W. 89	Spack Machine Co., F. W. 73
Automobile Utilities Co. 60	Franklin Mfg. Co. 80	Mathewson Motor Car Co. 99	Spake Motor Wheel of Am. 90
Auto-Shine Co. 61	Fry, T. C. & W. L. 60	Maxwell-Briacoe Motor Co. 111	Speed Changing Pulley Co. 82
Baldwin Chain & Mfg. Co. 66	G & J Tire Co. 82	Mayo Radiator Co. 63	Spicer Universal Joint Mfg. Co. 66
Barnett Drop Forging Co. 73	Gabriel Horn Mfg. Co. 82	Merchant & Evans Co. 87	Spittdorf, C. F. 61
Bartholomew Co. 88	Garford Motor Car Co. 96	Merritt & Co. 60	Sprague Umbrella Co. 94
Beaver Mfg. Co. 61	Gearless Transmission Co. 62	Metzger, C. A. 83	Standard Automatic Lub. Co. 61
Behen-Faught Motor Car Equip-ment Co. 61	Geiszler Bros. 65	Michelin Tire Co. 73	Standard Battery Connection Co. 72
Bellfuss Motor Co. 84	Gemmer Mfg. Co. 84	Midgley Mfg. Co. 66	Standard Co. 93
Beloit Supply Co. 89	General Accumulator & Bat-tery Co. 61	Miller & Starr. 85	Standard Connecting Rod Co. 69
Blasler Mfg. Co., M. E. 63	Gibney & Bros., Jas. L. 59	Miller, Chas. E. 86	Standard Roller Bearing Co. 69
Blomstrom Mfg. Co. 72	Goldberg Motor Car Device Mfg. Co. 79	Mitchell Motor Car Co. 96	Standard Welding Co. 83
Boker & Co., H. 66	Gray & Davis. Cover	Model Automobile Co. 84	Steam Carriage Boiler Co. 62
Bosch, Robert 99	Grout Bros. Auto Co. 108	Moline Automobile Co. 64	Stearns Co., F. B. 63
Boston Auto Gage Co. 67	Ham Mfg. Co., C. T. 82	Montgomery-Washburn Co. 85	Stevens-Duryea Co. 98
Bowser & Co., S. F. 86	Hans, Edmund E. 92	Mora Motor Car Co. Cover	Stewart & Clark Mfg. Co. 67
Boyle & Co., John. 110	Hardy Co., The R. E. 67	Morgan & Wright. 91	Streit Machine Co. 61
Brown Co. 90	Harris Oil Co., A. W. 61	Mosler & Co., A. R. 63	Studebaker Automobile Co. 83
Brown, Wm. W. 60	Hartford Suspension Co. 66	Moss Photo Engraving Co. 92	Success Auto Buggy Co. 65
Brownell Motor Co., F. A. 66	Hatcher Auto Parts Co. 83	Motz Clincher Tire & Rub. Co. 65	Supplementary Spiral Spring. 69
Brush Runabout Co. 94	Hatfield Motor Vehicle Co. 64	Mound Tool & Scraper Co. 82	Swinehart Clincher Tire Co. 82
Buckeye Jack Mfg. Co. 83	Haynes Automobile Co. 95	Mutty Co., L. J. 63	Syracuse Aluminum & Bronze Co. 66
Buckeye Mfg. Co. 64	Healy Leather Tire Co. 65	National Auto Accessories Co. 61	Thomas Motor Co., E. R. 74
Buffalo Carbuireter Co. 83	Hedgeland Mfg. Co. 97	National Brake & Clutch Co. 56	Thompson Sons Co., J. P. 71
Bullard Automatic Wrench Co. 84	Heinze Electric Co. 85	National Motor Vehicle Co. 108	Timken Roller Bearing Axle Co. 104
Buob & Scheu. 63	Heitger Carbuireter Co. 60	Neustadt Auto & Supply Co. 86	Tincher Motor Car Co. 95
Byrne-Kingston Co. 91	Hercules Auto Specialty Co. 92	Never-Miss Spark Plug Co. 81	Torbenen Motor Car Co. 73
Cadillac Motor Car Co. 64	Herz & Co. Cover	New England Motor Co. 87	Tray Plate Battery Co. 82
Cameron Car Co. 73	Hess-Bright Co. 66	New York Gear Works. 72	Treibert Gas Engine Co. 65
Canton Drop Forge & Mfg. Co. 66	Hicks Speed Indicator Co. 84	Nichols & Co., D. P. 63	Troy Carriage Sunshade Co. 91
Capitol Auto Co. 63	Hoffecker Co. 60	Nordyke & Marmon Co. 106	Tucker, C. F. 60
Carr, F. S. 63	Hoffman, Geo. W. 60	Northway Motor & Mfg. Co. 71	Uncas Specialty Co. 66
Chadwick Engineering Works. 75	Holley Bros. Co. 90	Northwestern Storage Battery Co. 91	U. S. Fastener Co. 85
Champion Co., A. 69	Holsman Automobile Co. 71	Nuttall Co., R. D. 66	Veeder Mfg. Co. 83
Chandlee & Chandlee. 68	Hopewell Bros. 65	Ofeldt & Sons. 60	Vehicle Specialty Corporation. 70
Chicago & Alton Railway. 67	Hotel Fredonia. 81	Olds Motor Car Co. 106	Walker Mfg. Co., E. C. 70
Clark, E. S. 60	Hotel Piney Woods Inn. 81	Owen & Co., R. M. 64	Waltham Mfg. Co. 76-77
Cleanola Co. 68	Hotel Rudolph. 81	Pacific Tucking & Mfg. Co. 60	Warner Instrument Co. 78
Cleveland Motor Car Co. 96	Hotel Tower. 81	Packard Electric Co. 61	Warner Pole & Top Co. 63
Cleveland-Canton Spring Co. 84	Hotel Westminster. 81	Packard Motor Car Co. 105	Watt-Detroit Carbuireter Co. 81
Columbia Lubricants Co. 82	Howard Motor Works. 64	Palmer & Singer Mfg. Co. 64	Waukesha Motor Co. 73
Comptoir d'Innovations pour Automobiles. 98	Hoyt Electrical Ins. Co. 72	Pantasote Co. 68	Wayne Automobile Co. 65
Conn. Tel. & Elec. Co. 93	Imperial Motor Car Co. 64	Parish & Bingham Co. 66	Weed Chain Tire Grip Co. 67
Continental Caoutchouc Co. 65	Indestructible Steel Wheel Co. 63	Parker, Stearns & Co. 83	Welch Motor Car Co. 88
Continental Motor Mfg. Co. 65	Jackson Automobile Co. 64	Penn. Auto Motor Co. 64	Western Motor Co. 83
Corbin Motor Vehicle Corp. 88	Jamesville Mfg. Co. 61	Perfection Grease Co. 87	Weston Elec. Instrument Co. 95
Cornish-Friedburg Motor Car. Correspondence School of Motor Car Practice. 59	Jeannin Auto & Mfg. Co. 88	Perfection Spring Co. 86	Wheeler & Schebler. 110
Cotta, Chas. 68	Jeffery & Co., Thos. B. 102	Peugeot Frères 66	White Co., The. 109
Cowles & Co., C. 60	Jeffery-Dewitt Co. 61	Pfanstiehl Elec. Laboratory. 60	Whitney Mfg. Co. 85
Crown Battery Co. 82	Jencick Motor Mfg. Co. 83	Picrome Hide Co. 66	Winton Motor Carriage Co. 112
Crown Soap Co. 84	Jenkins Specialty Mfg. Co. 84	Pierce Engine Co. 64	Witberbee Igniter Co. 67-96
	Johnson Sporting Goods Co., I. 67	Pioneer Brass Works. 66	Wright Cooler & Hood Co. 86
	Jones Speedometer 61	Pirelli & Co. 65	Wyman & Gordon Co. 59
	K. W. Ignition Co. 61	Pittsfield Spark Coil Co. 70	York Motor Car Co. 100
	Kellom Co., Chas. F. 69	Precision Appliance Co. 61	
		Premier Motor Mfg. Co. 107	
		Prest-O-Lite Co. 72	
		Progressive Mfg. Co. 72	

**CORK INSERTS**

(Patented)

**in any type of Clutch or Brake give results not otherwise obtainable**

**In 1908 Cork Inserts will be used in 15,000 cars**

- |                      |                             |
|----------------------|-----------------------------|
| George N. Pierce Co. | Leather-Faced Cone Clutches |
| Garford Co.          | Selden Motor Vehicle Co.    |
| Pope Mfg. Co.        | Studebaker Automobile Co.   |
| St. Louis Car Co.    | Tiley-Pratt Co.             |
| Dayton Motor Car Co. | "Long-Arm" System Co.       |
| Acme Motor Car Co.   | Conover Motor Car Co.       |
| Mora Motor Car Co.   | Kirkham Motor Mfg. Co.      |
| Olds Motor Works.    | Reliance Motor Car Co.      |
|                      | York Motor Car Co.          |

**Metal-to-Metal Cone Clutches**

- Knox Automobile Co.
- De Luxe Motor Car Co.
- Napier Motor Car Co.
- Roberts Motor Car Co.
- Mack Bros. Motor Car Co.
- Chadwick Eng. Works.
- Cameron Motor Car Co.

**Three-Plate Disc Clutches**

- Autocar Co.
- E. R. Thomas Motor Co.
- Nordyke & Marmon Co.
- American Machine Mfg. Co.
- Model Automobile Co.
- Abendroth & Root Mfg. Co.

**Expanding Ring Clutches**

- Coppock Motor Car Co.

**Five-Plate Disc Clutches**

- Dolson Automobile Co.
- Continental Motor Mfg. Co.
- Klink Motor Car Mfg. Co.
- New York Car & Truck Co.
- Imperial Motor Car Co.

**Multiple Disc Clutches**

- Rainier Co.
- Stevens-Duryea Co.
- Nordyke & Marmon Co.
- Northway Motor & Mfg. Co.

**Brakes**

- F. B. Stearns Co.
- Matheson Motor Car Co.
- Chadwick Eng. Works.
- Knox Automobile Co.
- Royal Motor Car Co.
- Premier Motor Mfg. Co.

**NATIONAL BRAKE AND CLUTCH COMPANY, Owner and Patentee, 16 State Street, BOSTON**

STANDARD BRAKE COMPANY, Representative, 101 West 66th St., NEW YORK

# THE AUTOMOBILE

## The Boston Show

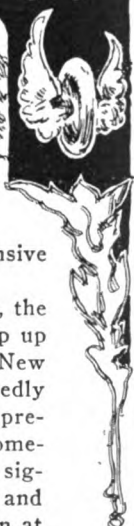

**B**OSTON, March 5.—Boston's annual automobile show, the event to which New England flocks to get its ideas as to the latest developments in motoring, will open Saturday night in Mechanics Building. It will be the sixth show of the Boston Automobile

Dealers' Association, and there is every reason to believe that it will maintain the high reputation that has been won among the trade by its predecessors. Always a large show, the exhibition of 1908 is to be on a grander scale than ever before, for it will include the whole of New England's greatest exhibition building. For some years past it has been the custom to set off the basement of the building for the motor boat manufacturers. This year, however, the motor boat men held a separate show, which makes available much additional space for the automobile exhibits. And all this extra space is needed, for the demand has been greater than in any previous year.

With more space at their disposal than formerly, Manager Chester I. Campbell and the directors of the Dealers' Association have been able to carry out several novel ideas. One of these is the establishment of a fully equipped repair shop in a section of the basement. In this department will be installed the latest machinery for automobile repairing, and it is intended to have the machinery in operation. This section, it is expected, will be of special interest to owners who

take care of their own machines, and to chauffeurs. Another feature of the basement will be the large amount of space allotted to commercial vehicles. A number of firms which build commercial vehicles have taken space, and it is anticipated that the display will be more comprehensive than at any previous show in Boston.

In the matter of decorations the Boston show, the pioneer in the uniform decorative idea, will keep up to past performances. Manager Campbell's New England apple orchard of a year ago was admittedly among the most novel show decorations ever presented, and he has put together for this year something equally attractive, though with less local significance. The central idea is Japanese in effect, and for days past a large corp of decorators has been at work transforming the huge, bare halls into the semblance of a tea garden of the far East.

In Grand Hall the back of the stage will be covered by a wide drop, upon which has been painted a typical Japanese scene, with snow-capped mountains in the background and with the Japanese flag, dragons and other symbolic figures for the top and sides. Great quantities of wistaria blooms will be used for the stage front. To cover the great beams of Grand hall a canopy of white bunting will be used, while in the very center will be suspended a chrysanthemum of

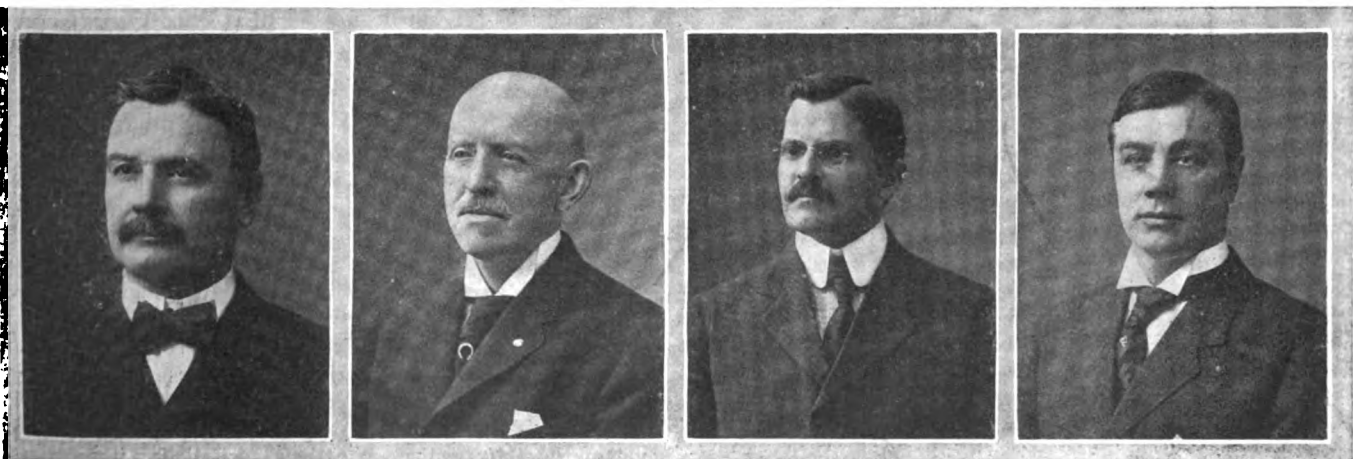

John H. MacAlman, President. George H. Lowe, Vice-Pres. Chester I. Campbell, Secretary. F. A. Hinchcliffe, Treasurer.  
OFFICERS OF THE BOSTON AUTOMOBILE DEALERS' ASSOCIATION, CONDUCTING THE BOSTON SHOW.



gigantic size, from which will run streamers to the sides and corners. In the center of the hall, where last year the band stand rested in the branches of an apple tree, has been built a magnificent fountain and basin with water spouting from eight jets. In the basin are to be placed gold fishes, and several massive palm trees will add to the picturesque effect of this central feature.

Instead of railings and fences, privet hedges are to be used to mark the dividing lines between the exhibition spaces, and at the ends of the hedges, along the main aisles will be placed bay trees. The sacred gates of Japan, which herald to the visitor the approach to a temple, have been erected over the principal aisles, and from them will droop wistaria blooms in profusion. The sides of the balcony are to be treated harmoniously with privet, bay trees and wistaria. For illuminating purposes thousands of electric lamps and Japanese lanterns will be employed.

In Machinery hall a similar system of decoration will be followed, the aisles being bridged with the sacred gates and great quantities of wistaria blooms being interwoven through a latticework. In the balconies, where are to be located the accessories departments, the general decorative scheme will be continued, and in the basement, also, there will be appropriate decorations.

To carry out further the Japanese effect of the show, Manager Campbell has employed many Japanese men and boys to act as pages and attendants, and these will be dressed in their native costume. The outside of the building will be adorned to some extent so as to give the visitor an idea of what he may expect after passing the turnstiles at the doors.

No lines between "licensed" and "unlicensed" cars are drawn at the Boston show, and for that reason it has been in the past the most complete in the country. This year

practically every manufacturer of any consequence has taken space, and many of the New York importers, both those who have Boston agents or branches and those who have not, are to exhibit. That the attendance will be large goes without saying. The Boston automobile show is the one event of the year, and the only one that fills the whole of Mechanics building with humanity. In addition to the great display of cars and their accessories, Manager Campbell has planned to entertain the great host of people with orchestral music in all the larger halls, and he has likewise made arrangements for the conduct of an excellent restaurant.

The interest that is being demonstrated in the show, both by the public and by the manufacturers and dealers, is the best justification the directors of the Dealers' Association could have of their attitude taken a year ago in opposition to the early show fever that swept the country. When it was announced just after the 1907 show that the next Boston show would be in March of 1908, there was much adverse criticism. Some of the members of the association believed that with the New York shows in the fall of 1907 the Boston dealers would have little or nothing to sell by March and that the value of the show would be lost. They brought much influence to bear to have the show date advanced to January, but Manager Campbell and the directors resisted this influence. As matters have turned out, March is the best possible time for the great New England motor exhibition. The dealers have plenty of cars to sell and they are all looking forward to the coming week to bring about a great boom in the retail business. Where a year ago the officers of the association were being roundly condemned, for not keeping up with the procession, now there is nothing but praise for their farsightedness in not being carried away by the early show idea.

## MASSACHUSETTS HOLDS AN AUTOMOBILE IS NOT A CARRIAGE

BOSTON, March 2.—An important decision, affecting broadly the rights of automobilists on the highways of Massachusetts has just been handed down by the full bench of the Supreme Court, the highest judicial tribunal in the State. It is in effect that an automobile is not a carriage within the meaning of the statute and that towns are not required to keep their highways in condition for automobile travel, providing they maintain them in a condition reasonably safe and convenient for travel generally. The court further holds that an automobilist who has not secured a State license to operate cannot recover from a town for an accident on a highway, even if defective for general travel.

The decision was made in the case of William C. Doherty against the town of Ayer. Mr. Doherty was driving his automobile on a town way known as Sandy Pond road on September 21, 1905. At that time the Lowell & Fitchburg Street Railway Company was preparing to lay tracks in the street and the automobile sank from eight to ten inches in the sand. In an effort to extricate it, the chain was broken and the machine sustained other damages. Mr. Doherty brought suit against the town, and in the Superior Court was awarded a verdict of \$100. The town took exception to the instructions of the judge presiding at the trial that an automobile was a carriage within the meaning of the revised laws, and that it was the duty of the defendant under the statute to keep its roads reasonably safe and convenient for automobiles, so that they might be protected.

The question raised was a novel one and the court in its decision holds that the town is not liable to one who is using an automobile and who is injured in a highway that would not be defective to travelers generally

and cause them injury. The town is not bound to keep its roads safe for automobiles. The court calls attention to the fact that in England even railway coaches are called carriages, but nevertheless such vehicles are not included in any statute which provides that a town shall keep its roads in a reasonably safe condition for carriages. An automobile, as is any vehicle propelled by a motor or engine, is more a machine than a carriage. In the present instance the court notes that the automobile referred to is frequently spoken of as a machine. In many places in this State, especially in unfrequented roads, a driver or an automobile owner would encounter difficulties as great or greater than those presented to Doherty.

A point in question as to whether Doherty was licensed and registered is taken up by the court, and although it is ruled, as far as the evidence goes, he was duly licensed and registered, the court holds that if he had not been he would not be a traveler on the highways in a legal sense. In such a case an automobile owner would have no remedy for damages sustained in a defective road.

The statute governing the liability of towns for accidents on their highways was passed by the Massachusetts Legislature in 1786. It provides that towns shall keep their ways safe for "travelers with their horses, teams and carriages."

Commenting upon the verdict, Francis Hurtubis, Jr., formerly counsel of the Massachusetts Auto Association, says:

"While I do not care to give the impression that I believe the Supreme Court has erred in handing down the decision, if it has held that an automobile is not a carriage in the meaning of the statute, I am greatly surprised, for it seems as if we had taken a step backward."

# BOSTON TO PRESENT A REPRESENTATIVE SHOW

In early days, when the cities outside of those entitled to hold shows of national importance first acquired the automobile show habit, Boston was among the very first to get in line. The affair was then purely a dealers' gathering, as are still many of the shows held in cities that started at the same time as the Hub. In the meantime, Boston has far outstripped its competitors—so far, indeed, that in speaking of the shows of the season, one never omits mention of the downeasters whose successful efforts in this direction have given them a strong hold on the distinction of being one of the "Big Three" shows of the year. Hence the importance of the Bay State's capital city as a show center.

When the early show idea took the trade organizations of the industry by storm last Fall, and the two strongest factors of the manufacturing community "fell for it," to put things in the vernacular, it was expected that Boston would follow suit as a matter of course, and when it was announced that the usual March dates would be adhered to there was more or less surprise expressed, though "It's only a dealers' show"

served to explain away a large part of this. But Boston is vastly more than a dealers' show, and the wisdom of sticking to what experience had proved to be the best course, does not require much explanation at the present writing.

It took many of the western manufacturers some time to get up their courage sufficiently to bring their exhibits on to New York for the annual line-up, and not a few cars that were staged in the Coliseum year after year never saw Broadway until 1906. Now they have reached the Back Bay and they will be there in force at the opening next Saturday night, is evident upon reviewing the accompanying list of exhibitors of complete cars. Add to this the fact that Boston is the home of not a few of the accessories and specialties that are known the country over, while many others first see the light in neighboring cities and the generous showing of exhibitors in this field speaks for itself, though accessory exhibits are not confined to home products by any means, as will be noted from the presence of well-known western makers in the long list of exhibitors of small wares.

## THE CAR EXHIBITS AND THE FIRMS WHO SHOW THEM

ACME—Boston Motor Co., 43 Columbus Ave., Boston.  
 ALLEN-KINGSTON—Allen-Kingston Motor Co., 887 Boylston St., Boston.  
 AMERICAN—W. A. Frederick Co., Motor Mart, Boston.  
 AMERICAN MERCEDES—H. C. Stratton, 741 Boylston St., Boston.  
 ATLAS—Harry Foadick Co., Motor Mart, Boston.  
 APPERSON—Fred S. Smith, 36 Columbus Ave., Boston.  
 AUTOCAR—Fred S. Smith, 36 Columbus Ave., Boston.  
 BABCOCK ELECTRIC—Curtis-Hawkins Co., 218 Elliot St., Boston.  
 BAKER ELECTRIC—Harry Foadick Co., Motor Mart, Boston.  
 BAILEY ELECTRIC—S. R. Bailey & Co., Amesbury, Mass.  
 BERLIET—Park Square Auto Co., 43 Columbus Ave., Boston.  
 BROUHOT—K. A. Skinner, 179 Clarendon St., Boston.  
 BRUSH—South End Car Co., 24 East Concord St., Boston.  
 CADILLAC—A. T. Fuller, Motor Mart, Boston.  
 CHADWICK—Curtis-Hawkins Co., 218 Elliot St., Boston.  
 CLARK—Edward C. Clark, 272 Freeport St., Boston.  
 CLEVELAND—Butler Motor Car Co., 12 Harcourt St., Boston.  
 COLUMBIA—Columbia Motor Vehicle Co., 74 Stanhope St., Boston.  
 COLUMBUS ELEC.—Algonquin Motor Car Co., 97 Massachusetts Ave., Boston.  
 CORBIN—Corbin Mfg. Co., 87 Church St., Boston.  
 CROWN BUGGY—Crown Motor Car Co., Motor Mart, Boston.  
 DE DION—K. A. Skinner, 179 Clarendon St., Boston.  
 DE LUXE—H. C. Stratton, 741 Boylston St., Boston.  
 DRAGON—Dragon Motor Co., 119 Massachusetts Ave., Boston.  
 ELMORE—F. R. Parker & Co., 288 Columbus Ave., Boston.  
 FIAT—Fiat Co., Boylston St., Boston.  
 FORD—Ford Motor Co., 147 Columbus Ave., Boston.  
 FRANKLIN—Franklin Automobile Co., 671 Boylston St., Boston.  
 FRAYER-MILLER—D. P. Nichols & Co., 118 W. Brookline St., Boston.  
 GLIDE—Crown Motor Car Co., Motor Mart, Boston.  
 GROU—Curtis-Hawkins Co., 218 Elliot St., Boston.  
 HOTCHKISS—Morgan B. Kent, 998 Boylston St., Boston.  
 IMPERIAL—Geo. H. Lowe, 27 State St., Boston.  
 KISSEL KAR—H. C. Stratton, 741 Boylston St., Boston.  
 KNOX—Reed-Underwood Co., 222 Columbus Ave., Boston.  
 LAMBERT—Chas. A. Eaton, 67 Pembroke St., Boston.  
 LANE—Lane Sales Co., 514 West 145th St., New York.  
 LEWIS—R. C. Lewis, Muncie, Ind.  
 LOCOMOBILE—Locomobile Co. of America, 400 Newbury St., Boston.  
 LOZIER—H. C. & C. D. Castle, 893 Boylston St., Boston.  
 MARION—W. A. Frederick Co., Motor Mart, Boston.  
 MARMON—F. E. Wing, Motor Mart, Boston.  
 MATHESON—Matheson Co., of Boston, Quincy Sq., Cambridge, Mass.  
 MAXWELL—Maxwell-Briscoe-Boston Co., 121 Massachusetts Ave., Boston.  
 MERCEDES—Allen-Kingston Motor Co., 887 Boylston St., Boston.  
 MITCHELL—W. M. Jenkins Co., 286 Columbus Ave., Boston.  
 MORA—Morrison-Price Co., 93 Massachusetts Ave., Boston.  
 NATIONAL—Linscott Motor Co., 163 Columbus Ave., Boston.  
 NORTHERN—Northern Motor Car Co., Detroit, Mich.

OAKLAND—Oakland Motor Car Co., Pontiac, Mich.  
 OVERLAND—W. A. Frederick Co., Motor Mart, Boston.  
 OLDSMOBILE—Algonquin Motor Car Co., 97 Massachusetts Ave., Boston.  
 PACKARD—A. T. Fuller, Motor Mart, Boston.  
 PEERLESS—Peerless Motor Car Co., 178 Columbus Ave., Boston.  
 PENNSYLVANIA—F. E. Randell Co., 66 Stanhope St., Boston.  
 PIERCE ARROW—J. W. Maguire Co., 745 Boylston St., Boston.  
 PIERCE RACINE—Butler Motor Car Co., 12 Harcourt St., Boston.  
 POPE-HARTFORD—Dodge Motor Vehicle Co., 25 Irvington St., Boston.  
 POPE-TOLEDO—Dodge Motor Vehicle Co., 25 Irvington St., Boston.  
 POPE-TRIBUNE—Dodge Motor Vehicle Co., 25 Irvington St., Boston.  
 POPE-WAVERLY—Dodge Motor Vehicle Co., 25 Irvington St., Boston.  
 P. & S.—Palmer & Singer Co., 1620 Broadway, New York.  
 PREMIER—Premier Boston Depot, 1008 Boylston St., Boston.  
 PULLMAN—F. E. Randall Co., 66 Stanhope St., Boston.  
 RAINIER—Morrison-Price Co., 93 Massachusetts Ave., Boston.  
 RAMBLER—Thos. B. Jeffery Co., 145 Columbus Ave., Boston.  
 RAPID—Butler Motor Car Co., 12 Harcourt St., Boston.  
 RENAULT—Renault Frères Selling Branch, New York.  
 REO—Linscott Motor Co., 163 Columbus Ave., Boston.  
 ROYAL TOURIST—Geo. J. Dunham, 188 Columbus Ave., Boston.  
 SCHACK—Ferd. F. French, Sudbury St., Boston.  
 SHAWMUT—Shawmut Motor Co., Stoneham, Mass.  
 SIMPLEX—Palmer & Singer Co., 1620 Broadway, New York.  
 SPRINGFIELD—Mills-Kennedy Co., 733 Boylston St., Boston.  
 SPRINGFIELD—Harry Foadick Co., Motor Mart, Boston.  
 STANLEY—Stanley Motor Carriage Co., Newton, Mass.  
 STEARNS—Morgan B. Kent, 998 Boylston St., Boston.  
 STEVENS-DURYEA—J. W. Bowman Co., 811 Boylston St., Boston.  
 STILSON—F. E. Randall Co., 66 Stanhope St., Boston.  
 STODDARD-DAYTON—Park Square Auto Co., 43 Columbus Ave., Boston.  
 THOMAS—Whitite-Gilmore Co., 907 Boylston St., Boston.  
 VIKING—A. R. Bangs, 25 Elliot St., Cambridge.  
 WALTER—Fred G. Smith, 36 Columbus Ave., Boston.  
 WAYNE—Morrison-Price Co., 93 Massachusetts Ave., Boston.  
 WALTHAM-ORIENT—Waltham Mfg. Co., Waltham, Mass.  
 WELCH—Mills-Kennedy Co., 733 Boylston St., Boston.  
 WHITE—The White Company, 320 Newbury St., Boston.  
 WINTON—Winton Motor Carriage Co., 1 Stanhope St., Boston.

### MOTORCYCLES.

CROUCH—Crouch Motor Co., Stoneham, Mass.  
 F. N.—Ovington Motor Co., 2234 Broadway, New York.  
 INDIAN—Hendee Manufacturing Co., Springfield, Mass.  
 LIGHT—Light Mfg. & Foundry Co., Pottstown, Pa.  
 MARSH—American Motor Co., Brockton, Mass.  
 MERKEL—Merkel Motor Co., Milwaukee, Wis.  
 RELIANCE—Reliance Motor Cycle Co., Oswego, N. Y.  
 R. S.—Reading Standard Co., Reading, Pa.  
 THOR—Aurora Automatic Machine Co., Aurora, Ill.

## THE PARTS AND ACCESSORY PEOPLE WHO HAVE EXHIBITS

### PNEUMATIC AND SOLID TIRES.

Automobile Utilities Company, 88 Broad St., Boston, Mass.  
 Ajax-Grieb Company, 1776 Broadway, New York.  
 Ball Bearing Tire Company, 159 Avon St., Providence, R. I.  
 Columbia Vehicle Tire & Top Co., 97 Haverhill St., Boston, Mass.  
 Commonwealth Rubber Company, Lowell St., Reading, Mass.  
 Diamond Rubber Company, Akron, O.  
 Dow Tire Company, 104 W. Forty-second St., New York.  
 Empire Tire Company, Trenton, N. J.  
 Firestone Tire & Rubber Company, Akron, O.  
 Flsk Rubber Company, Chicopee Falls, Mass.  
 G & J Tire Company, Indianapolis, Ind.  
 B. F. Goodrich Company, Akron, O.  
 Goodyear Tire & Rubber Company, Akron, O.  
 Hartford Rubber Works Company, Hartford, Conn.  
 Leather Tire Goods Company, Newton Upper Falls, Mass.  
 Michelin Tire Company, Milltown, N. J.  
 Morgan & Wright, Detroit, Mich.  
 Pennsylvania Rubber Company, Jeannette, Pa.  
 St. John Rubber Company, 88 Broad St., Boston, Mass.  
 Voorhees Rubber Company, 40 Bostwick Ave., Jersey City, N. J.  
 Zeglan Bullet-Proof Cloth Company, 520 W. Division St., Chicago, Ill.

### BATTERIES, MAGNETOS, IGNITION.

Anderson Spark Plug Company, 100 Boylston St., Boston, Mass.  
 Auto Igniter Company, 1947 Broadway, New York.  
 Bemus Company, T. Alton, Inc., 385 Atlantic Ave., Boston, Mass.  
 Champion Company, Albert, 36 Whittier St., Boston, Mass.  
 Connecticut Telephone & Elec. Company, Meriden, Conn.  
 Duplex Coil Company, 5 Park Square, Boston, Mass.  
 Eastern Carbon Works, Jersey City, N. J.  
 Electric Storage Battery Company, Philadelphia, Pa.  
 Heinz Electric Company, Lowell, Mass.  
 Monitor Distributor Company, 49 Federal St., Boston, Mass.  
 National Carbon Company, Cleveland, O.  
 Never-Miss Spark Plug Company, Lansing, Mich.  
 Pittsfield Spark Coil Company, Dalton, Mass.  
 Stackpole Battery Company, St. Mary's, Pa.  
 Westchester Appliance Company, Yonkers, N. Y.  
 Witherbee Igniter Company, 1876 Broadway, New York.

### LAMPS AND HEADLIGHTS

Atwood Manufacturing Company, Amesbury, Mass.  
 Connell, W. J., 36 Columbus Ave., Boston, Mass.  
 Gray & Davis, Amesbury, Mass.

### ACETYLENE GAS APPLIANCES, TANKS.

Acetyvone Company, 38 Park Row, New York.  
 Eco Manufacturing Company, 53 State St., Boston, Mass.  
 Preat-O-Lite Company, 607 Boylston St., Boston, Mass.

### LUBRICANTS, LUBRICATING APPLIANCES, TANKS.

Bowser & Company, S. F., Ft. Wayne, Ind.  
 Columbia Lubricants Company, 116 Broad St., New York.  
 Eagle Oil & Supply Company, 104 Broad St., Boston, Mass.  
 Dover Stamping & Manufacturing Company, Cambridge, Mass.  
 Dixon Crucible Company, Joseph, Jersey City, N. J.  
 Harris Oil Company, A. W., Providence, R. I.  
 Haws, George A., 73 Pine St., New York.  
 Gilbert & Barker Mfg. Company, 51 Union St., Boston, Mass.  
 Kellon, Charles F., 128 Arch St., Philadelphia, Pa.  
 N. Y. & N. J. Lubricants Company, 14 Church St., New York.  
 Randall-Falchney Company, 251 Causeway St., Boston, Mass.  
 Robinson's Sons & Co., W. C., 44 Commercial Wharf, Boston, Mass.  
 Underhay Oil Company, 73 Battermarch St., Boston, Mass.  
 Vacuum Oil Company, Rochester, N. Y.

### SHOCK ABSORBERS.

Ciglia Shock Preventer Company, 176 W. 72d St., New York.  
 Gabriel Horn Mfg. Company, 976 Hamilton Ave., Cleveland, O.  
 Hartford Suspension Company, 67 Vestry St., New York.  
 Kilgore Manufacturing Company, Oldtown, Me.

### SPEED INDICATING INSTRUMENTS.

Hoffecker Company, 222 Elliot St., Boston, Mass.  
 Jones Speedometer Company, 76th St. and Broadway, New York.  
 Jones, William Herbert, 147 Columbus Ave., Boston, Mass.  
 Motor Car Specialty Company, 112 No. Broad St., Philadelphia, Pa.  
 Parker Manufacturing Company, Roxbury, Mass.  
 Smith Manufacturing Company, R. H., Springfield, Mass.  
 Warner Instrument Company, Beloit, Wis.  
 Veeder Manufacturing Company, Hartford, Conn.

### ACCESSORY AND SUPPLY DEALERS.

Angler Company, 735 Boylston St., Boston, Mass.  
 Chandler & Farquhar Company, 36 Federal St., Boston, Mass.  
 Downing, C. J., 54 Warren St., New York.  
 Gordon Auto Supply Company, 215 Elliot St., Boston, Mass.  
 Miller, Charles E., 97 Reade St., New York.  
 Pettingill-Andrews Company, Pearl St., Boston, Mass.  
 Post & Lester Company, Hartford, Conn.  
 Proctor Supply Company, 25 Irvington St., Boston, Mass.  
 Wilkinson & Company, A. J., 180 Washington St., Boston, Mass.

### TIRE CASES, APPLIANCES, ETC.

Gilbert Manufacturing Company, New Haven, Conn.  
 Hopewell Brothers, 42 Osborn St., Cambridge, Mass.  
 Teel Manufacturing Company, Medford, Mass.

### MOTORS, CASTINGS, PARTS, MACHINERY,

American Rotary Motor Company, 208 Devonshire St., Boston, Mass.  
 Boston Gear Works, Norfolk Downs, Mass.  
 Coates Clipper Manufacturing Company, Worcester, Mass.  
 Cramp & Sons Company, Wm., Philadelphia, Pa.  
 Defiance Chain Company, 148 Federal St., Boston, Mass.  
 National Auto Accessory Company, 84 State St., Boston, Mass.  
 New England Motor Company, Lowell, Mass.  
 Norton Grinding Company, Worcester, Mass.  
 Vim Motor Company, Sandusky, O.  
 Whitney Manufacturing Company, Hartford, Conn.

### MISCELLANEOUS EXHIBITORS.

Aetna Life Insurance Company, 4 Liberty St., Boston, Mass.  
 Auto List Publishing Company, 8 Beacon St., Boston, Mass.  
 Automobile School, Y. M. C. A., Boston, Mass.  
 Baldwin & Company, Bangor, Me.  
 Boyd, F. Shirley, 889 Boylston St., Boston, Mass.  
 Boston Auto Gage Company, 8 Waltham St., Boston, Mass.  
 Boston Auto Light Company, 924 Pleasant St., Boston, Mass.  
 Brown Folding Stool Company, 27 Dock Square, Boston, Mass.  
 Campbell, H. F., 5 Park Square, Boston, Mass.  
 Century Optical Company, 442 Central Park West, New York.  
 Colgan Company, J. W., Sudbury Bldg., Boston, Mass.  
 Chase Company, L. C., 89 Franklin St., Boston, Mass.  
 Consolidated Optical Mfg. Company, 112 W. 31st St., New York.  
 Cutter, J. Frank, Cambridge, Mass.  
 Daniels, W. S., 52 Church St., Boston, Mass.  
 Draper, J. B., & Company, Brunswick, Me.  
 Elite Manufacturing Company, Ashland, O.  
 Fuller & Sullivan, 19 Elliot St., Boston, Mass.  
 Globe Optical Company, 403 Washington St., Boston, Mass.  
 Gunn, Arthur S., 218 Tremont St., Boston, Mass.  
 Hillman Auto Supply Company, 446 Tremont St., Boston, Mass.  
 Howard Company, F. H., Watertown, Mass.  
 Leonard Brothers, Waukegan, Ill.  
 Maiden Leather Goods Company, 2 Park Square, Boston, Mass.  
 Maryland Casualty Company, 84 State St., Boston, Mass.  
 Melrose Automobile Company, Melrose, Mass.  
 Massachusetts Auto Company, 52 Church St., Boston, Mass.  
 Moore-Smith Company, 250 Devonshire St., Boston, Mass.  
 Morse, Alfred Cutler, Motor Mart, Boston, Mass.  
 Murray & Company, P. A., Newton, Mass.  
 National Valgrinock Company, 200 Summer St., Boston, Mass.  
 N. E. Lighting Company, 169 Congress St., Boston, Mass.  
 Nolan, William, 541 Tremont St., Boston, Mass.  
 Nonpareil Brass Company, 283 Dyer St., Providence, R. I.  
 Non-Exp. Safety Naphtha Container Company, 185 Summer St., Boston, Mass.  
 Pantasote Company, 11 Broadway, New York.  
 Robinson, Duncan, 89 State St., Boston, Mass.  
 Russell, T. F., 22 Lincoln St., Boston, Mass.  
 Sage's Trunk Depot, 81 Summer St., Boston, Mass.  
 Salman & Company, John A., 21 Bromfield St., Boston, Mass.  
 Shove & Gage Company, Inc., Providence, R. I.  
 Smith Company, W. J., New Haven, Conn.  
 Solderline Company, 91 Oliver St., Boston, Mass.  
 Speare, F. P., Y. M. C. A., Boston, Mass.  
 Stanley, John T., 650 W. 30th St., New York.  
 Suthergreen, F. S., Manchester, Mass.  
 Thompson Company, Judson L., Waltham, Mass.  
 Ward, E. T., 23 Purchase St., Boston, Mass.  
 West & Dodge, 384 Atlantic Ave., Boston, Mass.  
 White & Bagley Company, Worcester, Mass.

# Experiences of Boston's Pioneer Autoist

Massachusetts, having the four which now occupy his garage. His present equipment consists of a Model K Winton limousine, a Model M Winton touring car, a 20-horsepower



BOSTON, March 5.— In the local automobile clubs, when the old-timers get to talking the ancient history of automobiling, it is not uncommon to hear them refer to such and such an event as happening "in the year George Morrill got his

first steamer," or "the year George Morrill drove the little De Dion," or "the year George Morrill brought over the big six-cylinder Napier." To the novice this is all Greek, for though he very likely knows George Morrill, Jr., of Norwood (not to know him is a confession of little acquaintance with automobiling in Boston), he very likely is not familiar with the fact that automobiling in Boston began with Mr. Morrill, and that for the past fifteen years he has been one of the most ardent owners and drivers of motor vehicles in this State and in the country at large.

Mr. Morrill is president of the George H. Morrill Company, manufacturers of printing inks, whose large factory is one of the leading industries of Norwood, Mass. He makes his home in the same town, where he has a beautiful estate, including a large mansion, fully stocked stable and a motor house of large proportions. His estate is one of the sights of the town, and his motor house is known far and wide among automobilists for its complete equipment and appointments. While he is an enthusiastic automobilist and has attended many of the motoring events of importance in America and abroad, he has never used his cars with a view of establishing touring or speed records, making use of them largely for the convenience of himself and his family.

At least three things stand out prominently in Mr. Morrill's career as an automobilist: he owned the first car that was seen on the streets of Boston; he drove the first six-cylinder car seen in this part of the country; and he has owned probably as many automobiles as any other man in

Napier runabout, and a Maxwell runabout, the last largely used by his son. This is rather a small equipment for him, as he has customarily had at least a half dozen cars at a time.

Mr. Morrill began his motoring career in September, 1893, when he became possessor of a single-cylinder runabout made by Charles Duryea, of Springfield, Mass. The car was shipped from Springfield to Boston, and when it made its appearance on the streets the crowds that assembled were so large that it was only with great difficulty that the automobile was driven through the city and to the home of its new owner in Norwood. It was on this occasion that the term "Get a horse" is said to have originated, though other sections make claim to the distinction of having originated this opprobrious ejaculation, formerly the bane of the automobilist, but happily now rapidly falling into disuse. The little machine made its initial trip without serious trouble, and people followed it nearly to the outskirts of the city. Long after that whenever Mr. Morrill was expected along the road crowds gathered at the corners much as they do along the parade route of a circus.

### Regrets that He Did Not Save His First Car.

This first machine in Boston was a crude affair, compared with the latest products of the factories. The engine was under the footboard and the transmission was through a countershaft to the rear wheels, the power being transmitted by means of a series of belts. Chains were not then in use. The motor was rated at 10 horsepower, and there were three speeds ahead and one reverse. Speaking of his first experiment in motoring, Mr. Morrill said to THE AUTOMOBILE representative: "I have often wished that I had saved that first car, just to show what a fool a man could be. If I made it go five miles without a stop I thought I was having lots of fun. A little later, when I proposed buying another car, Mrs. Morrill sized up the situation well when she said that with the first machine I was lucky if I got out of the yard, and with the new one I would be lucky if I got back."

The second car owned by Mr. Morrill, also a Duryea, was bought in 1894, and he went over to New York to see it per-



"The Pines," Norwood, Mass., Home of Geo. H. Morrill, Jr., Owner of the First Automobile Driven in Boston.

Mr. Morrill is seated in the touring car on the extreme right of the picture. Behind the touring car is Mr. Morrill's Maxwell, containing his son, and behind that is his Napier runabout, containing Mrs. Morrill. On the left in front of the house is Mr. Morrill's limousine. His motor house is in the rear of the mansion.



form in the John Brisben Walker race from the city hall up to Ardsley and return. The race started, and for ten miles or so Mr. Morrill followed the car with a pair of horses. The longest trip he made with this car was from Norwood to Providence and return, and the journey took two days. Mr. Morrill frequently makes the same trip with one of his present cars in a few hours. At that time he was able to buy gasoline at five cents a gallon, and when the price was raised to eight cents it seemed to him like extortion. There was no need of sirens and other forms of warning, for the machine made noise enough itself to warn everything else out of the way. People were known to have stood beside the road for three hours to watch the contrivance go by. In 1895 Mr. Morrill drove his automobile to the Brockton fair, and it was the first machine that had been seen there. The car was a greater attraction for the fair visitors than the Midway, the prize cattle, or the balloonist.

#### Mr. Morrill Also Owned a Number of Steam Cars.

After several years' experience with the Duryea gasoline cars, Mr. Morrill turned to steam, which seemed to be in the ascendancy, and his first steamer was a Locomobile of the small runabout type. Then he had in succession five Stanley steamers, and the Stanley brothers always took great pride in keeping Mr. Morrill's cars equipped with the very latest devices and improvements. Thus he had one of the first ball-bearing cross heads and one of the first superheaters. These early steam cars gave good satisfaction compared with the earlier gasoline vehicles, but Mr. Morrill eventually went back to gasoline explosion motors and has used them steadily ever since. At one time he owned two small De Dions, then much in vogue in Boston and vicinity, and at other periods he drove a Rambler, Pierce Arrow, a Stevens-Duryea, and other well-known makes of American gasoline cars.

He has owned five Wintons, and bought the first Winton car sold by Harry Fosdick when he became manager of the Boston branch of the Winton company. That was in 1902. The following year he purchased another Winton, and in 1904

bought a third. His other Wintons are the two which he is now using and which constitute the chief members of his "stud."

It was in 1904 that Mr. Morrill introduced the six-cylinder to Boston. He went abroad in the summer, and while in England with Charles J. Glidden, the world-girdling automobilist, bought of S. F. Edge & Co., Ltd., a six-cylinder Napier. With this car he toured in England, and also drove to the Gordon Bennett race in Germany. He brought the car home in June, 1904, and drove it for several years, using it on his trips to the Florida tournaments in 1905 and 1906. Said Mr. Morrill: "That car cost me in all \$12,000, and I sold it last year for \$1,900. I am through with foreign cars, and have no use for anything but those made in America. I also do not care for six-cylinders. I believe that if a properly made four-cylinder and a properly made six-cylinder were placed side by side, and a man were asked to tell which was which without seeing them, he would be unable to do so. They talk a great deal about better balance and all that sort of thing, but I don't see it, and I have had experience."

#### His Hospitality Is Noted and His Garage Is Ideal.

Recently Mr. Morrill had his garage, formerly 35 feet square, enlarged to 35 by 55 feet. It is equipped in the most up-to-date manner with granolithic flooring, turntable, pits, stands, washing space, and the like, and he is about installing electric lights. Everybody who travels the New York road through Norwood knows that in case of emergency he will find all sorts of supplies in the Morrill garage, and Mr. Morrill is the kind of automobilist that believes in helping his brother sportsmen when in distress. His automobiles are always at the disposal of his friends, of whom he has many, and it is not a strange sight in Norwood to see a cavalcade of three or four automobiles filled with people leaving the Morrill estate for a run to some point of interest. Mr. Morrill has kept no account of his mileage, and does not know how many thousand miles he has traveled, but each summer he does much touring, usually making a trip into the mountains, and he keeps his cars going all through the Winter.

## S. A. E. TO MEET AT BOSTON, MARCH 10 AND 11

THE first quarterly meeting of the Society of Automobile Engineers for the present year will be held at Boston during the course of the show there. It will be opened on Tuesday evening by the reading of a paper on electrical ignition by J. O. Heinze, at the Massachusetts Institute of Technology. The following morning, at 9:30, the members will rendezvous at the headquarters of the Bay State Automobile Association where a number of cars will be waiting to convey them to Lowell, Mass. Lunch will be served at the Lowell country club, and immediately following this the members will pay a visit of inspection to the laboratory and factory of the Heinze Electrical Company, which is said to be one of the best equipped plants of its kind in the country. Two hours are to be allowed for the 30-mile drive back from Lowell. A dinner will be held at the Bay State Automobile Association, and this will be followed by the reading of papers.

Among the subjects on which papers have been prepared, are "Perfecting Automobile Ignition," by J. O. Heinze; "Design of Automobile Crankshafts," by P. M. Heldt; "A Multiple Unit System as a Solution of the Heavy Goods Transportation Problem," by Joseph A. Anglada; and "Automobile Forgings," by Richard W. Funk. The reading of the papers will be followed by a discussion of the points brought out by the different authors in the course of their papers, and in this, the members of the Bay State Automobile Association have been invited to join.

Mr. Heinze's paper deals with a phase of the subject of electrical ignition on the automobile that has received only

too little attention in the past, and his researches and experiments on the subject, which have probably been more extensive and thorough than have ever been undertaken in this country, show in a highly interesting manner just why automobile manufacturers found the maintenance on a car of what appeared to be an insignificant current, such a difficult and vexatious problem to solve. So little had been done in this field hitherto that Mr. Heinze had to devise his own instruments for testing and they are very ingenious.

In his paper, Mr. Heldt briefly sums up what has been learned regarding the design of that most important part of the motor—the crankshaft. He shows why there have been so many failures in the design of this essential, as well as the influence of the method of manufacture on the production of an enduring crankshaft, in addition to which he dwells at some length on the new two-bearing crankshafts for which the adoption of the block type of motor has been responsible. Mr. Anglada has made a close study of the problem of economical heavy goods transportation by means of the multiple unit system of haulage, using a gasoline-electric tractor and self-propelled units controlled from the latter, as well as of the tire problem in connection with this most important automobile development. "Automobile Forgings" is a title that is self-explanatory, but in his paper Mr. Funk confines himself to what he has learned in the actual production of many hundreds of motor crankshafts by different methods of forging and with different materials. It is probable that the summer meeting of the Society will be held in Detroit.

# BOSTON as an Automobile Mart



BOSTON, March 5.—Being the mercantile heart of New England, as well as the "Hub of the Universe," it is natural that Boston should early assume an important position in the automobile trade, and to-day there are few cities, if any outside New York and Chicago, which have as large a number of dealers in motor vehicles. When the industry was in its infancy the concerns that first essayed to manufacture on a business basis looked to Boston for encouragement, and some of the first agencies and branches in the country were established here. Keeping pace with the wonderful growth of the industry, the trade in Boston has grown and broadened until from a couple of stores on Boylston street and one or two in the old bicycle section of Columbus avenue, the business has increased until it includes a half hundred well-established concerns, occupying most of the stores on large sections of Columbus avenue, Boylston street and Massachusetts avenue and representing nearly four score different makes of automobiles.

Though the development of the trade in Boston has been extremely rapid, it has been built up on the firm Boston basis of conservatism, and the wisdom of this sort of progress has been amply demonstrated during the past three months or more. While automobile dealers in some other cities have been worrying about the prospects for 1908, the Boston dealers as a rule have been doing a steady business and the number of new concerns that have entered the field indicates that, in the opinion of those closely connected with the trade, the New England field is susceptible of much future development. The number of foreign agencies that have been established is a feature of recent developments.

There is scarcely a car which has gained any recognition whatever that is not on sale in this city, and some of the dealers have built up most profitable businesses handling one line of cars year after year. Such an instance is Alvan T. Fuller, recognized as one of the leaders in the local trade. Years ago Mr. Fuller entered the automobile business. He was only a boy in years and only a few of his intimate friends know now how few years have passed over his head. After handling various cars, Mr. Fuller secured the agency for the Packard, and he has handled it ever since, making it easily one of the most popular automobiles in New England. Mr. Fuller also has handled the Cadillac with success for several years.

Another dealer who has made a success by sticking to one line is J. W. Maguire, the Pierce agent. Mr. Ma-

guire graduated into the automobile business from the bicycle trade, and he obtained the agency for the Pierce a number of years ago. By conscientious at-

tention to his work and through the medium of a first-class car he has built up a large trade in this vicinity. Another veteran of the trade is W. E. Eldridge, of the Stranahan-Eldridge Company, the Buick agents. Mr. Eldridge was once the manager of the Pope branch, and after leaving that employment he

formed with Mr. Stranahan the present company. Another old-timer who has graduated from branch management into business for himself is A. E. Morrison, of the Morrison & Price Company, the Rainier and Wayne agents. Mr. Morrison was for many years with the Peerless company, but for the last few years he has been handling different lines of cars.

E. A. Gilmore, of the Whitten-Gilmore company, is one of the best-known automobile men in this section of the country. He was long with Thomas B. Jeffery & Co., as a manager of the Boston branch, and in this capacity he became acquainted with the trade throughout the New England territory. With Mr. Whitten, long in the automobile business in Lynn, Mr. Gilmore is now handling the Thomas line. Perhaps no man in Boston has been better known than J. M. Linscott, of the Linscott Motor Company. In the old bicycle days the Linscott road race was a famous event. Mr. Linscott early entered the automobile business and his firm is well known as the agency for the National and the Reo.

Among the branch managers are a number of men who have grown up with the trade in Boston. J. S. Hathaway, who presides over the destinies of the White company, operating two large garages besides a constantly growing sales department, has been connected with the company for many years. F. A. Hinchcliffe, the Winton manager, was in the automobile business in Boston way back when practically the whole product was steam cars. Then he went to New York and from there to Boston several years ago as Winton manager. John L. Snow, the Peerless manager, has worked his way up in the trade from demonstrator to salesman and two or three years ago was appointed branch manager. John H. MacAlman, manager of the Columbia branch, was for years with the Locomobile company in Boston and is one of the leaders in local trade circles. He is president of the Boston Automobile Dealers' Association, which holds the Boston show. F. J. Tyler, the manager of the Maxwell-Briscoe Boston company, entered the automobile trade only a few years ago,

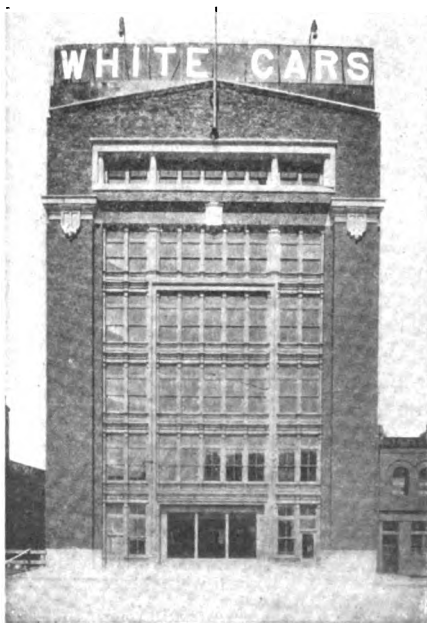

The New White Garage In Boston.

This building, completed by the White Company last fall, is the largest garage building in New England. It is located on Newbury street, near Massachusetts avenue, and opposite the White Boston branch.



and the Kissel Kar, and the George H. Lowe Company has the agency for the American Mors.

One of the older branch houses is that of Thomas B. Jeffery & Co., which has been established on Columbus avenue almost from the beginning of the business. The manager is V. A. Charles, who was promoted a year or more ago after serving as salesman. The Ford company also has a prosperous branch alongside that of the Rambler, and the manager is Charles E. Fay, formerly with the Winton Company in Boston. The Dragon, Franklin and Studebaker companies also maintain branches in Boston.

Among the newer automobile concerns are the Algonquin Motor Car Company, of which A. E. Adams is manager, and which handles the Oldsmobile; W. M. Jenkins & Co., which handles the Mitchell; the Premier Boston depot, with Henry L. Johnson as manager; F. R. Parker, agent for the Elmore, and C. A. Eaton, agent for the Lambert. The Harry Fosdick Company, agent for the Springfield and the Atlas, is a concern of several years standing and has one of the finest show rooms in the city. Other leading dealers include the Custis-Hawkins Company, of the Motor Mart, agent for the Chadwick and the Grout; F. E. Wing Motor Car Company, agent for the Marmon; W. A. Frederick Company, agent for the American and Overland; Crown Motor Car Company, agent for the Glide; Boston Motor Car Company, agent for the Acme; Everett S. Litchfield, agent for the Austin; E. P. Blake Company, agent for the Jackson and the Logan; Fred



but he has succeeded in making the Maxwell known from one end to the other of his territory. K. M. Blake, the manager of the Locomobile branch, is comparatively a newcomer in Boston, but in the few years he has been here, though laboring under great difficulties, he has established an enviable clientele for the Locomobile.

The foreign cars are represented more strongly in Boston at the present time than ever before. One of the latest branches opened is that of the Fiat Automobile Company, with S. H. Baker, formerly connected with the J. W. Bowman Company, the Stevens-Duryea agents, as manager. Another new foreign car branch is that of the Panhard & Levasor company, with George T. Gould, formerly of New York, as manager. A. C. Morse has lately taken the agency for the Renault, and the Darracq company also has a local agency, while Morgan B. Kent handles the Hotchkiss as well as the Stearns. American-made models of foreign cars are also well represented here. The Park Square Auto station, of which C. F. Whitney is manager, has the agency for the Berliet as well as the Stoddard-Dayton; H. C. Stratton & Co. handle the American Mercedes along with the Car De Luxe

S. Smith, agent for the Apperson, Autocar and Walter; George J. Dunham, agent for the Royal Tourist and Corbin; Reed-Underhill Company, the Knox agent; F. E. Randall Company, agent for the Pennsylvania, Pullman and Stilson; Mills-Kennedy Company, agent for the Welch; Allen-Kingston Company, agent for the Allen-Kingston; H. C. & C. D. Castle, the Lozier agent; J. W. Bowman Company, the Stevens-Duryea representative; Roy E. Faye, the Matheson agent; the Dodge Motor Vehicle Company, representing the Pope line, and the Butler Motor Car Company, representing the Cleveland.

A list of the principal Boston dealers and the cars for which they are agents is as follows:

- Curtis-Hawkins Co., Motor Mart.....CHADWICK, GROUT, BABCOCK.
- Harry Fosdick Co., Motor Mart.....ATLAS, SPRINGFIELD, BAKER.
- A. T. Fuller, Motor Mart.....PACKARD, CADILLAC.
- F. E. Wing Motor Car Co., Motor Mart.....MARMON.
- W. A. Frederick Co., Motor Mart.....AMERICAN, OVERLAND.
- Crown Motor Car Co., Motor Mart.....GLIDE.
- Boston Motor Car Co., Motor Mart.....ACME.
- Park Square Auto Station, Motor Mart.....BERLIET, STODDARD-DAYTON
- Everett S. Litchfield, Motor Mart.....AUSTIN.
- E. P. Blake Co., 21 Hawkins St.....JACKSON, LOGAN.
- Fred S. Smith, 36 Columbus Ave.....APPERSON, AUTOCAR, WALTER.
- T. B. Jeffery & Co., 145 Columbus Ave.....RAMBLER.
- Ford Motor Co., 147 Columbus Ave.....FORD.
- Linscott Motor Co., 163 Columbus Ave.....NATIONAL, REO.
- Peerless Motor Car Co., 178 Columbus Ave.....PEERLESS.
- George J. Dunham, 189 Columbus Ave.....ROYAL TOURIST, CORBIN.

- Winton Motor Carriage Co., 1 Stanhope St... WINTON.
- Reed-Underhill Co., 222 Columbus Ave..... KNOX.
- F. E. Randall Co., 245 Columbus Ave..... PENNSYLVANIA, PULLMAN, STILSON.
- W. M. Jenkins Co., 286 Columbus Ave..... MITCHELL.
- Columbia Motor Vehicle Co., 74 Stanhope St... COLUMBIA.
- Franklin Automobile Co., 671 Boylston St.... FRANKLIN.
- Mills-Kennedy Co., 733 Boylston St..... WELCH.
- H. C. Stratton & Co., 741 Boylston St..... AM. MERCEDES, DE LUXE, KISSÉL KAR.
- J. W. Maguire Co., 745 Boylston St..... PIERCE.
- Allen-Kingston Motor Car Co., 887 Boylston St. .... ALLEN-KINGSTON.
- Flat Automobile Co., 885 Boylston St..... FIAT.
- Morgan B. Kent, 889 Boylston St..... STEARNS, HOTCHKISS.
- H. C. & C. D. Castle, 893 Boylston St..... LOZIER.
- Panhard & Levassor Co., 901 Boylston St.... PANHARD.
- Shawmut Motor Car Co., 901 Boylston St.... SHAWMUT.
- Stranahan-Eldridge Co., 823 Boylston St.... BUICK.
- Whitten-Gilmore Co., 907 Boylston St..... THOMAS.
- J. W. Bowman Co., 911 Boylston St..... STEVENS-DURYEA.
- The White Co., 320 Newbury St..... WHITE.
- Premier Boston Depot, 1008 Boylston St.... PREMIER.
- Studebaker Automobile Co., Boylston St.... STUDEBAKER.
- Maxwell-Briscoe Boston Co., 121 Mass. Ave.. MAXWELL.
- Dragon Motor Co., 119 Massachusetts Ave... DRAGON.
- Locomobile Co. of America, 400 Newbury St.. LOCOMOBILE.
- Algonquin Motor Car Co., 97 Mass. Ave..... OLDSMOBILE, COLUMBUS.
- Morrison & Price, 93 Massachusetts Ave.... RAINIER, WAYNE.
- George H. Lowe Co., 509 Tremont St..... AEROCAR.
- Roy E. Faye, Quincy Sq., Cambridge..... MATHESON.
- A. C. Morse, 222 Elliot St..... RENAUULT.
- Coburn-Perclival Co., 179 Clarendon St.....
- Stanley Motor Carriage Co., Newton..... STANLEY.
- Dodge Motor Vehicle Co., Irvington St..... POPE.
- Butler Motor Car Co., 12 Harcourt St..... CLEVELAND.
- F. R. Parker, 288 Columbus Ave..... ELMORE.
- C. A. Eaton, 22 Concord St..... LAMBERT.

## MAINE'S SHOW WAS A MOST SUCCESSFUL EXHIBITION

PORTLAND, ME., March 2.—Proving more successful than either of the two exhibitions held in the city before, the third Portland automobile and motor boat show has last week attracted hundreds of visitors to Portland. The big Auditorium was thronged daily, and the show has given an impetus to the automobile trade in Portland the like of which has not been experienced since the industry gained a foothold in the State. Frederick M. Prescott, of Malden, Mass., fresh from the successful Providence, R. I., show, had promised that the decorations for the Portland exhibition would be better than anything else ever shown in the city. He kept his word and many were the words of praise spoken for the artistic and sumptuous way in which the big auditorium was decorated.

In one thing Mr. Prescott was rather unfortunate, and that was in not being able to secure the entire Auditorium. The destruction of Portland's handsome City Building had caused a number of the city officers to take up their quarters in the Auditorium. They occupied the basement and exhibits were consequently excluded from this part of the building. But the main floor nearly made up for the deficiency. Every available inch of space was engaged. The following were the exhibitors and their exhibits:

Boothbay Gas Engine Co., motors; F. A. Nickerson Co., Oldsmobile; Geo. D. Thorndike Machine Co., Mianus motors; W. L. Blake Co., marine motors, oils; The Stanley Co., Stanley marine motors; Vacuum mobilolls; Camden Anchor-Rockland Machine Co., Know motors; Palmer Bros., Palmer engines and boats; Smith & Langmaid, Casco engines; Chas. F. Guptill Co., marine hardware; Harmon Automobile Co., Franklin, White steamers; F. A. Wentworth, Overland, Marion; Gray & Prior Machine Co., marine engines; Thos. Laughlin Co., marine hardware; Alvan T. Fuller, Packard; The James Bailey Co., automobile accessories; Swan & Stuart, Cadillac; Portland Automobile school; Harris Auto Oil Co., oils; Frank M.

Low, automobile and motor boat clothing; The Darling Automobile Co.; The Underhay Oil Co.; The Automobile Journal; Evans Stamping & Plating Co.; The Angier Co.; The Randall-Falchney Co.; J. B. Draper Co., automobile robers; Stoughton-Folkins Co., Maxwell; F. A. Nickerson Co., Pierce Great Arrow; Spear Auto Co., For and Fairbanks marine motors; L. C. Gilson Co., Reo, Stanley, Premier; Maine Motor Carriage Co., Stevens-Duryea, Pope-Hartford, Peerless; The Portland Co., Know automobiles.

The general tendency of the Maine market is toward a smaller and cheaper car, and many orders for these types were taken at the show. The runabouts have found especial favor with the physicians and business men who have been searching for a small car in which they may go easily to and from their summer residences. In considering Maine as an automobile market, it must be borne in mind that while the State is as large as all the remainder of New England put together, much of it is still an almost virginal wildness, so far as travel through it is concerned. The lumberman with his chief adjuncts, the saw mill and paper factory, has laid waste hundreds of square miles, but there never were any roads through these immense tracts, and had it not been for the pressing demand for lumber, there would not now be the logging trails which are their sole means of communication. Automobiling is consequently confined, in very large measure, to the southeastern corner of the State and consists principally of traffic between the cities and the seashore resorts, although more and more tourists are now braving the logging trails of the inland country each summer, and it is expected that the coming season will see a marked increase in the number of these itinerant auto camps in the Maine woods.

Up to the present time, 2238 automobiles have been registered in Maine, and as a result of the show, this number will be greatly increased before the Summer is over.



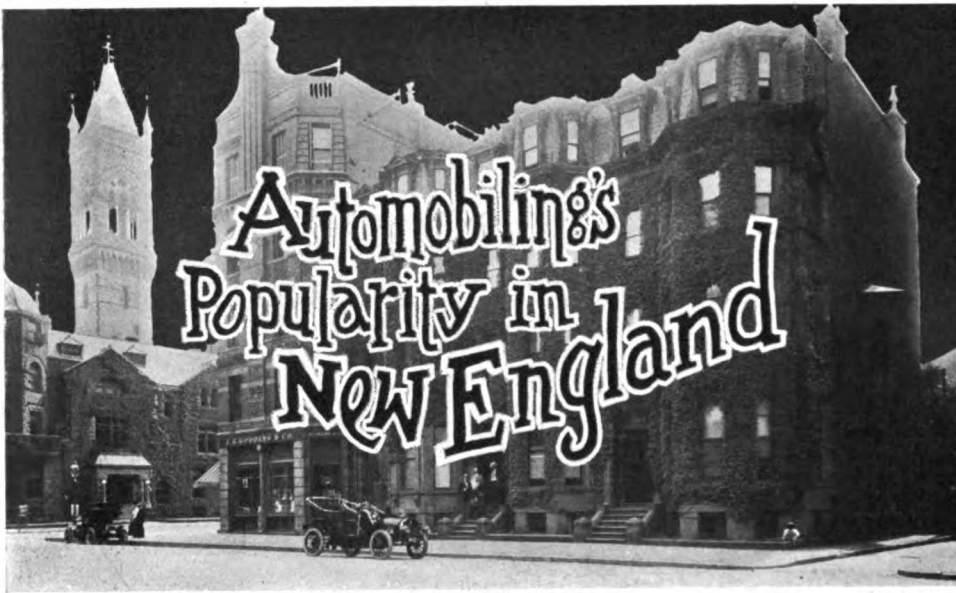

Bay State Automobile Association Clubhouse, Dartmouth Street, Boston.

**B**OSTON, March 5.—In the opinion of those automobile men who are customarily well posted on the condition of the business, the outlook for 1908 in New England does not possess many of the gloomy characteristics it is supposed to have in other sections of the country. They cannot see how the sale of cars is to be materially diminished during the coming season, when the general business situation has already taken an optimistic trend. All through the period of depression in New York and the West not a single automobile concern in Boston suffered apparent financial distress, and many of them report that their business so far this winter has been better than during the corresponding period of any previous year. People of Boston and of other sections of the territory have bought cars, others have placed orders for spring delivery, and the number of "prospects" is reported larger than usual. All this before the Boston show, generally considered the real beginning of the selling season hereabouts.

Dealers attribute this most satisfactory condition of affairs primarily to the fact that the people of New England are conservative in their business methods and do not rush into things unless they are pretty certain of their value. And when the pinch comes they are less likely to be caught. Secondly, the glowing prospect for the coming season is attributable to the fact that a large section of this territory with great purchasing power is only beginning to be developed for the sale of automobiles. Competition has had the result recently of causing the dealers to reach out from the cities into the country for trade, and it is not at all uncommon for a Boston automobile salesman to make a trip to the up-State towns or up to Vermont, New Hampshire and Maine and bring back several orders. One well-known dealer makes a practice of sending a car on journeys to the smaller towns, thereby interesting their residents in the cars. In this way, by means of a few demonstrations to the leading men, he has caught a large number of customers and interested "prospects" which could not be reached in any other way.

Massachusetts is by all odds the best of the New England states for automobile business. It has more miles of good roads, the largest population, and the highest valuation. Boston, the largest city, has the largest number of automobiles and is the richest field, but such cities as Worcester, Springfield, Lynn, Salem, and the other cities of secondary size offer a rich field for the sale of automobiles. The State of Connecticut cannot be worked to advantage from Boston, and in distributing territory it is a rare case to assign Connecticut, except, perhaps, the eastern section, to a dealer in

Boston. It is much more common to assign Nutmeg State agencies from New York, and New Haven has grown to be an important distributing center.

Providence is one of the liveliest automobiling cities in New England. Providence has a flourishing club which holds each year a hill climb of more than local renown, and the city also has its own automobile show, the recent show held in the new armory having been one of the best small exhibitions given outside the larger cities. To some extent the Boston dealers sell cars in Providence, a few of them having that city in their territory. Providence, however, has many dealers who look out for the people of their state.

North of Boston, according to a Boston dealer who controls the whole of Northern New England,

Vermont is the best State for automobiles. This statement was made recently in the presence of a number of automobile men, and it created somewhat of a surprise, for few, who had not had experience, had much idea that there was a market in the Green Mountain State. There are many hilly roads and not as much has been done in the way of development of the highways as in some of the other New England States. Nevertheless, each year a good number of cars are shipped into Vermont, and it is estimated that several thousand vehicles are in constant use during the driving season.

New Hampshire is also assuming considerable importance as an automobiling State. Two or three of the larger cities have automobile clubs, and there are several thousand machines owned and bearing the number tag of the Granite State. The State government is doing a large amount of road work, especially in the way of developing through routes from the southerly to the northerly section of the State. There are three principal routes. One leads up the Connecticut valley partly in Vermont and partly in New Hampshire, and crosses over to the White mountains. The second is the Merrimac valley route through Nashua, Manchester and Concord, and the third is the western route, from Portsmouth through the Ossipee to the White mountains.

The hotel men of the White mountains have also done much to stimulate automobile touring, and Bretton Woods early became one of the best-known automobile rendezvous in the country. It has been the destination or the turning point of two Glidden tours, and the "Climb to the Clouds" up Mt. Washington is world-famous. At first automobiling in New Hampshire was chiefly by non-residents, but within the past few years many residents have joined the ranks.

Maine, though it has thousands of acres of territory with no better roads than a logging track, has taken a great liking to the automobile, and the red and white number tags of the Pine Tree State are very common all over New England. There are many strongly established agencies in Portland, and several Boston firms maintain branch agencies in the city. Portland has an automobile club which is alive to the possibilities of touring and which has done much work.

Just how many automobiles there are in New England is difficult to say. It is generally considered that there are from 12,000 to 14,000 machines owned in Massachusetts, and probably there are as many more in the other States. Doubtless 25,000 machines in actual operation is a conservative number, while in the summer the number probably is increased by fifty per cent. by visitors from other States who come to New England for a longer or shorter period.

# From the Oranges to Cape Ann



By J. Grant Cramer

The Lighthouse at the Entrance of Gloucester Harbor, a Locality Famed in Song and Story.

**B**RIGHT and early on the first day of October, Miriam, "Olive," and I set out for Boston. Miriam, "Blue Book" in hand, filled the rôle not of prophetess, but of pilot; I was engineer, and "Olive," strong of engine but gentle of voice, carried us without trouble, as she had done for many thousand miles before. It was cold, and the wind blew from the north so that we were glad indeed that we had brought an abundance of heavy wraps with us. We passed through Hacksack, whose police are said to be unfriendly to autoists, but it was too chilly for their zeal to blossom out so early in the morning. At Fort Lee we crossed the ferry, and soon we were on the old Boston Post road driving through the "neutral ground" of the Revolutionary days, which extended from the American lines along the Byram River to the British lines near Kingsbridge. The unfortunate inhabitants of this territory "feared every body whom they saw and loved nobody," for they were harried and robbed by bands of ruffians who gave allegiance now to King, now to Congress, as happened to be most profitable to them. But quickly the sad, far-off past fades away and is forgotten in the beauties of the present scene, as the eye is continually delighted by the broad Sound, with its irregular coastline of lovely bays and inlets and countless islands—Nature's emeralds in their gleaming setting.

Going on we came to the pretty little city founded two and a quarter centuries ago by the Huguenots, who named the settlement after their old French home, La Rochelle. Later, in Revolutionary days, the Hessians landed there and camped near the site of Larchmont. Passing the yacht club, "Olive" soon purred through the fine streets of Mamaroneck, Harrison, and Rye. The latter was settled by sturdy English colonists, who were not at all disturbed by the fact that the Dutch West India Company had purchased that territory and that possibly some Dutchmen might think they had something to say about the land.

The Pilot did her duty well, and it saved us much time to have her give the directions for the numerous turns and forks in the roads and streets. Her task of "conning" us through Portchester was not an arduous one, and in a short time we had left the Empire State and were in New England, which we entered by a region of beautiful estates, of which Greenwich contained perhaps more than any other city along our journey. From the road we could

see that the coastline had become more rugged with promontories standing out into the Sound, sheltering beautiful harbors. Down from the smiling hill country of Connecticut, through dear little valleys, flowed small rivers, the Byram, the Mianus, and other streams. The early settlers of this district finally united with the Connecticut Colony. They were good fighters, as the Indians and afterwards the British found to their cost. Right here in Greenwich, after the defeat of his little band by a greatly superior force, General Putnam escaped from the English by riding down the stone steps which were originally cut for the use of the devout on their way to and from the little church that stood on the hill during those troublous times.

Our undulating road now led us a little more inland through Stamford and Darien, and at the top of one hill we had a superb view looking far out over the Norwalks and the Sound. Three years after the Declaration of Independence all but six of the houses of Norwalk were burned by Tryon's troops, who did not accomplish their purpose, however, until they had had severe losses inflicted upon them by fifty Continentals and a few militia men.

Leaving Norwalk, the Boston post road led us through the charming rural Green's Farms and through Southport, where the Pequot Indians were finally nearly wiped out by Massachusetts and Connecticut troops. Southport has a large public library, the "Pequot Library," the gift of a wealthy citizen, which presents a fine appearance from the charming village street. In Fairfield, with its beautiful green and main street shaded by its grand old trees, we seemed to come upon the first of many lovely villages that we were to see, of each one of which one could say that it was a "typical New England village. Busy, manufacturing Bridgeport, the home of the late P. T. Barnum, was quickly left behind, and soon we drove through the quaint streets of Statford. It did not take us long to cover the four miles between Stratford and Milford, whose early church members must have had an uncommonly good opinion of themselves if we may judge them from some of their resolutions, of which the following are specimens:

"Voted: That the earth is the Lord's and the fulness thereof."

"Voted: That the earth is given to the Saints."

"Voted: That we are the Saints."



Scenes Near Picturesque Cape Ann.

At Stratford one should turn off to the left to go to the Berkshires by way of the Naugatuck and Housatonic valleys, but as we were going to Boston we headed toward New Haven, which we reached after a delightful drive along the shore road and past Savin Rock. At New Haven we took on gasoline because we had planned to spend our first night in Wallingford, where we wanted to call on friends, about twelve miles north of the "Elm City." As we drove up to the boarding school where two small cousins were staying, the children, who were up in an apple tree, clambered down and ran out, exclaiming: "Oh, Cousin Grant, we recognized 'Olive's' voice and knew you had come." For be it known, "she" was an old friend of theirs and had taken them for many a delightful all-day trip last Summer. As there was no garage in the village, "Olive" had to rest among carriages in a livery stable, where her lodging cost as much as at one

the branches of its great elms meeting above us. Continuing along the "Old Boston Street"—the Boston Post Road under another name—we were soon in Clinton, where in 1701 Yale College was founded; after six years the college was transferred to Saybrook, and in 1717 was finally established in New Haven. Another joy awaited us in the beautiful broad street of Saybrook Center, whose macadam is a continuation of the State road, which is better than the rather worn highway between New York and New Haven.

A little further on we came to the Connecticut river, fortunately just in time to catch the small ferryboat, to board which we drove down a steep gangway, where the grade must have been between 30 and 40 per cent. We asked why a bridge had never been built across the river at this place, and were told that the cost would be too great, as the traffic did not warrant its construction. Four thousand cars



Map of Lower New England, Showing the Popular Course for Tourists to Cape Ann.

of the best garages in Boston. We, however, were well taken care of. Our hotel was built by one of the early editors of the *New York Sun* as his residence, and was a fine example of a stately old country home. We thought the three richly carved mantel-pieces alone worth the trip from New York.

In the morning we drove down to New Haven, and to Branford and Guilford, which have two of the most beautiful greens that we passed through on our trip. The Branford green is very large and around it are the principal buildings—the churches, the town hall, the public library. The trees on the Guilford green are so close together as to give it the appearance of a large grove of fine elms as one approaches. An interesting building is the "Old Stone House," built by the early settlers in 1640 for their minister, Mr. Whitfield. The walls are of stone, three feet in thickness, well able to resist the attacks of murderous Indians of those days.

To such lovers of trees as the Pilot and myself the main street of the little village of Madison was a joy, with

had passed during the summer, but at less than a dollar per car with its passengers the revenue would not be very large. The two towns that maintain the ferry devote a part of the profits to improving the roads in their immediate vicinity and spend the rest on schools, etc.

On the other side, a steep sandy hill necessitated low gear work, but at the top the road became good and brought us into Lyme, beloved of artists, from which it was not a long run to New London. A short distance beyond we came to a glorious view over the Sound, with its many inlets, a foretaste of what we were to have on the morrow; but not for long, for soon after leaving Stonington darkness began to fall, and we found the macadam road to Westerly closed for repairs. This necessitated a long detour over an unknown country road, which was very narrow and at times led through woods and thick underbrush. In some places it would have been impossible for two vehicles to pass each other. This delay, however, did not prevent us from reaching the little Rhode Island town without difficulty in time for a

late dinner. Our hotel was a barn of a place; the rooms were very large with immensely high ceilings, so that one wondered how they could ever be heated. When we rose next morning we thought that Winter had surprised us, but found that it was warmer out of doors than in the house.

Beyond Westerly we came into a stony country with a charm peculiar to itself; gray boulders peeped up from the fields; stone fences and low shrubbery lined the roads, all their tones soft and lovely, blending harmoniously into each other. Here and there were dashes of color, where the sumach and the maple had thrown out flame signals, the exceeding glory of their foliage telling of its approaching death. To the right were magnificent views of the Sound with its countless bays, inlets, estuaries and lovely islands, on which we feasted our eyes as we bowled over the smooth undulating roads. But a few miles before reaching Charlestown we had to come back to earth, for a narrow road with deep sand required some attention. At one place a gang of men were doing something to the road; by no stretch of the imagination could they be said to be repairing it. They were simply throwing loose earth in the shape of huge clods on top of the deep sand, so that "Olive" had first to climb up and over some hillocks of clods and then drop off into the sand on the other side. If it had not been for her double three point suspension and full elliptic springs we should have been well shaken; as it was, we only rocked as if in a boat or a cradle. A little beyond Charlestown the State road gladdened our eyes, but we had to leave it promptly, as it was being repaired, and go around by way of Green Hills. This we were not sorry to do, for the country road was good and we passed through some lovely woodland scenery before rejoining the macadam that carried us toward Narragansett bay.

#### Striking Back Inland from the Sea.

We were almost sorry when we reached Narragansett, for we knew that we should soon lose sight of the sea. The Pier was utterly deserted and produced a rather depressing effect on one who had seen it during the height of the season. Here a garage keeper told us that a little further on we should come to a fork in the roads; in all probability a boy would be there who would tell us to leave the State road because of repairs and take the left fork, which would ultimately bring us back to the main highway. The garage keeper told us that a few evenings before, finding the road barred, he alighted, threw the bars into the underbrush in a field and went on. Sure enough, going on we met the boy, but heeded his admonition to turn to the left, and it was well that we did, for when a few miles further on we swung back into the main road a few rods from the bars, we saw a man crouching in the bushes, evidently ready to jump out to arrest disobedient motorists who had run past the boy. Such actions as those of our counsellor are what tend to bring automobilists into disrepute and to make them disliked.

A little way out of Narragansett Pier we crossed a curious, old covered bridge which reminded us of similar bridges in Switzerland. Soon after leaving Apponaug we turned into the avenue bearing the same name. This street and its neighbor, Elmwood avenue, are as fine roads as I have ever traveled over, either on this side of the Atlantic or on the other. It certainly required strength of character not to exceed the speed limit. With the throttle lever opened but a trifle more than half an inch from the fully closed position, the speedometer indicated twenty miles an hour. But if the approach to Providence was swift and delightful, the passage through it was slow and tedious. We had to crawl owing to the congestion of traffic in the business portion of the city and to the bad pavements, and as for the drive to Pawtucket, I cannot do better than to quote the words of our guide book: "If there is anywhere a four-mile stretch with more turns in it than the run from Providence to Pawtucket, the 'Blue Book' has yet to hear of it."

We did a very simple thing, however; we tacked on behind a trolley car marked "Pawtucket," and, following that, we had no difficulty in finding our way. Shortly after leaving the town we came on to the State road which extends to Boston, and had a grand road all the way to North Attleboro, where we spent two days with friends. A delightful drive of thirty-three-miles through lovely little towns and villages brought us into Boston through the Fenways, and the afternoon of that day was spent in driving through the Newtons and visiting Auburndale, where I spent a year as a youth.

On the following day we started for a run to Cape Ann and back—a round trip of about 84 miles. We bumped over the Belgian blocks of Washington street, crossing Washington bridge, and went through Charlestown and Chelsea, which certainly seemed to justify what the Bostonians say about it, "as dead as Chelsea." Several miles of blocks had to be covered before we reached macadam, and then came a long stretch of good road across the salt meadows near Revere. To some they might have a bleak, almost desolate look, yet the cocks of salt hay and the wide expanse of meadow, with here and there patches of red, had a charm of their own. Then through Lynn, with its pretty suburb of Swampscott, on streets shaded by fine trees, through which we caught glimpses of the sea, we went on.

Soon we came to historic Salem and crossed a long bridge over Beverly Harbor into Beverly. From Beverly through Magnolia and Manchester up to Gloucester the fine road winding, now near the shore, now a little distance from it, is lined much of the way with fine shade trees and beautiful summer residences. At times one has the impression of driving through a beautiful park.

Gloucester is a picturesquely situated little town, famous for its men who can sail any craft that carries canvas. For about two or three miles beyond Gloucester the road was bad, very rough, muddy and rutty; after that it was good nearly all the way around Cape Ann. The views along the rugged western shore were beautiful, and the little village of Rockport was quaint and curious. It was interesting to see the men dressed in their Sunday best gathered in groups, lounging about the streets of these little towns, and when some of the younger natives shouted, "He's 'way from New Jersey," we realized that to them New Jersey seemed a distant land, and to us as well, for our departure from East Orange seemed more than a few days before—as we looked back over the successive pageants of fields, woods and sea and realized the store of beautiful memories that we had accumulated. The country in its October brilliance—with its foliage gorgeous beyond what we had ever seen—the uniformly clear, fine weather, the absolute reliability and freedom from trouble of our good car, all contributed to make this a delightful and never-to-be-forgotten trip that it would be difficult to duplicate on this side of the Atlantic.



Where "Mother Ann's" Jutting Rocks Meet the Sea.



## SEVEN HUNDRED MILES IN NEW ENGLAND

By STANLEY W. COOK.

**S**TARTING from Springfield one summer morning, we headed the machine over the well-trodden path towards Boston. This road, which on the whole is in the very best of condition, is marred by one stretch of very poor road about seven or eight miles long. The run to Boston was a most glorious one. Each of the six cylinders kept perfect time with its mate and nary a skip. What more could one wish for?

Leaving Springfield, we passed the large grounds of the Springfield Armory on the left, and going up a gradual incline came to the level, smooth road that took us out of the city on the way to North Wilbraham. Here there is a bad undergrade crossing that makes a short turn, cutting off the view of the road ahead. Passing through here the next town we came to was Palmer, a very peculiar place to get through if one is not acquainted with the numerous turns. Between Palmer and West Warren came the bad stretch of road which is actually a disgrace, when one considers that this is the main through route leading across the State.

The road then passed through a series of New England towns, among which is the town of Leicester, well known to most motorists. Here two years ago I had the pleasure of making the personal acquaintance of Constable Quinn, who was kind enough to show me the way to the Worcester Court House.

From Worcester there was a choice of several different routes to Boston. We decided on the well-marked and most frequented one by way of Shrewsbury, Marlboro, Sudbury, and Weston, all the way on fine macadam. We arrived at our hotel in Boston just 4 hours 10 minutes after starting. The entire run was made on the high gear without a stop.

### Taking in the Sights of Boston and Vicinity.

The afternoon was spent around town on various errands, and in the evening we took a short ride through the Fenway, one of the noted park systems of Boston. One could spend a most profitable week making short runs around the Bay State Capital over some of the most beautiful and historical drives imaginable. The next afternoon we ran up the North shore as far as Swampscott and back, a run of 52 miles, including a detour through Charlestown. The roads were perfect and the boulevard follows the shore most of the way, passing through Lynn and Revere Beach.

The third afternoon was spent meandering slowly along the South shore as far as Nantasket Beach, passing through many interesting and historical places. This day only 42 miles were made. It was economy, however, to run through this part of the country at a very careful pace, as the officers of the law believe in making motorists run slow enough to fully appreciate the beauties of their towns.

The fourth day we started off bright and early for a run down to the end of Cape Cod. We followed the South shore as close as possible, and then continued on the inside part of the cape down to the little old historical town of Provincetown. A stop for lunch was made at Plymouth, where the Plymouth Rock is held up as the center of attraction. The roads on the whole were in very excellent shape, with the exception of a few stretches of sand down near the end, which, however, did not cause any trouble. The hotel was little more than could be expected in such an out-of-the-way place. As for the mosquitoes, if there could be a competition arranged between the Provincetown and the New Jersey lances I'd put all my money on the Provincetown variety. The distance for the day was 141 miles, which we did in 6 hours 30 minutes, sufficient proof of the quality of the roads that abound in this vicinity.

The next day the start was made at 9:30 A.M., and after retracing quite a bit of the previous day's run we cut across the cape to the outside edge. Considerable sand was met, but nowhere sufficient to use the low gear, most of it being covered without even using the second. We stopped for lunch at Wiano, a small summer place pleasantly located on the shore. The hotel here went by the demure name of Cotochesett. After lunch the run was continued on through New Bedford and Fall River to Providence, covering in all 160 miles. The road between New Bedford and Fall River is a most tempting one for friendly brushes with other cars. It is quite wide and runs through open country most all the way, with practically no hills and nearly straight.

### On the Way Home from Roger Williams' City.

The sixth and last day of the trip was from Providence to Springfield, the starting point. This part of the road was familiar to me, as I had been over it several times before, so no time was lost asking the usual questions and consulting guide books. We left Providence at just 9 o'clock and from there went first down to Narragansett Pier. From Providence to the Pier was very evident the way in which fast driving will tear up the roads if they are not kept in constant repair. Two years ago when I went over this same stretch it was in excellent shape. Now at the turns the inside is all worn off to the lower foundation of coarse rock, while on the outside the loose stones have been piled up in regular ridges where they have been thrown by cars skidding around the turn. On some straight stretches two regular grooves have been cut through the top dressing such as no slow-moving teams could do.

Near New London came our first tire trouble, a puncture that required quite a bit of work to fix up, though not much time was lost. After passing through a series of toll gates and ferries, we at last came to the mouth of the Connecticut river where it empties into Long Island Sound. After crossing to the other side on a little ferryboat that looked ready to fall to pieces most any moment, we started up the river, following it closely the rest of the journey, passing through Hartford and Windsor Locks, where the river was recrossed, entering Springfield by the way of Long Meadow. This last day's run was 175 miles, making a total of 675 miles as the distance between towns; this added to what running we did around Boston in the mornings we were there made a little over seven hundred miles as a total.

### The Car and the Weather Agreeable.

With the exception of the one puncture and the changing of one spark plug, the run was made without any trouble at all. As we sat at dinner that night everyone came to the conclusion that for real true enjoyment nothing can go ahead of the combination of a willing car, good roads, and fair weather, and nowhere else in the country are the last two essentials of the combination to be found to such an extent as in New England. The downeast brand of weather is almost as good as the majority of its main roads. There are stormy days to be sure, but they are not frequent and seldom come together in one of those continued stretches that make touring unpleasant. In anything but downright bad weather, it is possible to get along without any great difficulty if covering the ground be the tourist's chief desire, as the macadam roads are generally in such shape that it takes far more than an ordinary storm to make them at all difficult for automobiling. But one is scarcely in a mood to enjoy scenery under such conditions, and the New England variety is worth seeing.

## QUAINTEST CAPE COD WHICH RESISTS MARCH OF PROGRESS

By ARTHUR R. WILLCOX.

A GREAT sandbar venturesomely stretching out seventy miles into the ocean; its jagged edges forming scores of pretty harbors; its wild dunes capped here and there with a lonely lighthouse or a "wireless station," and its beaches dotted with quaint hamlets, fishermen's shacks, and life-saving stations; with its ever-present suggestion of the sea, and the quaint characters who make this neck of land a separate country, isolated from the mainland and apart from the times: that is Cape Cod.

Barnstable, Buzzards Bay, Yarmouth, Provincetown—these are names that instantly suggest the one heritage of the old days that has been preserved inviolate against the assaults of time. And yet, isolated and antique though it be, the Cape Cod country is fast becoming a paradise of motorists; the "devil wagon," as well as the locomotive, pushing its way to the farthest point.

The western portion of the cape, as far east as Chatham, is covered with a network of excellent roads, which furnish a veritable scenic railway ride to the many automobilists who are touring the cape in ever-increasing numbers. The lower part of the cape is already a popular summer resort; but those who, in these latter days of rush and strenuousness, love to linger amid the scenes of former days and study the quaint characters that inhabit this picturesque locality, find the seaward end rich in the treasures they seek.

Those who select the automobile as the key to the real "Quaintest Cape Cod" of the eastern end, had best provide themselves generously with horsepower, for the "network of fine roads" finally simmers down to one turnpike, with miles of hub-deep sand that only the hardy survive; and the arrival of an automobile at Cape Cod excites as much interest as the arrival of the trains—which reach the end of the cape in apparent comfort despite the roller-coaster aspect of the railroad.

Between Chatham and Orleans there are eight miles of sand almost impassable for the automobile, but as this stretch may be avoided by keeping on the northern route, there remain only two bad stretches of a few miles each, which are a good test for the machines and supply their own

reward to those who succeed in conquering them. In going through the first of these two stretches the autoist must follow the telegraph poles in a general way, mapping out his own route, and exercising extreme care to avoid traveling in the road. But there are rich rewards in store for those who survive these sandy stretches, and the rolling, winding road, paralleling the little single-track railway, skirting the water's edge, hemmed in by the vast stretches of bay and ocean, and cooled by delightful breezes, is a shore drive that cannot be duplicated anywhere.

From South Wellfleet, where the steel towers of the Marconi wireless station are picking up messages from over the sea, through miles of wildest sand dunes, with an occasional village or lighthouse, to fishy Provincetown, where the Pilgrims first set foot on American soil, the ride is one never to be forgotten.

Provincetown, the quaintest of relics of the old days, though it contains comfortable hotels, lays no claim to fame as a resort, its chief attraction to the tourist being the quaint atmosphere that has been preserved against the romance-blighting march of progress. Here one may see the old "town crier" treading his way slowly through the little street, ringing his bell and shouting in a weather-beaten voice the announcements on his day's list. The air at times is freighted with the pungent odor of codfish, drying by the thousands on racks at the water's edge.

The big blue sweep of Cape Cod Bay is dotted with ships; the land stretches back southward in one long narrow curve to the misty mainland—and everywhere else is the sea. Up at "the lookout" bronzed old salts study the movements of ships in the offing and speculate on the weather possibilities, or discuss the beautiful Pilgrim's monument which is now being erected in commemoration of the landing of the forefathers at this spot, while down at the wharf are landing pilgrims to the shrine of Antiquity, reverently treading the hallowed ground, eagerly imbibing the sounds and sights and smells of Provincetown, and, far from the prosaic atmosphere of the cities, are living for a few golden hours another existence, among the picturesque Cape Cod folks.

### FOR THOSE FINED NEAR ALBANY, N. Y.

ALBANY, N. Y., March 2.—About the first of October, 1906, the authorities in the town of East Greenbush, Rensselaer County, conceived the idea of raising enough funds to build new bridges and take care of the poor of the town at the expense of automobile tourists who passed through there.

Nearly every one approaching Albany from the East or South has to travel over a stretch of macadam road, beginning at the town of Schodack and passing through the town of East Greenbush. This new State road is contiguous with a number of miles of very poor clay road. Consequently nearly every autoist who travels over this road is very apt to run his car to the limit of twenty miles an hour.

Jesse P. Van Ness, the justice of peace, secured the services of a number of deputy sheriffs and started his trap, and thereby collected from automobilists \$800. During the fall of 1906 and the summer of 1907 there was practically \$800 spent and retained by this justice of peace. A taxpayers' action has been brought by residents for an accounting.

As many automobilists have contributed to this fund, it is requested that any person reading this notice, who has paid a fine in this town, send his name with date of arrest and amount of fine levied to Bender & Hinman, attorneys, 81 Chapel street, Albany, N. Y.

### WOMEN'S CLUB RUNNING CALIFORNIA SHOW.

SAN FRANCISCO, Feb. 26.—After the Dealers' Association of San Francisco had discussed an automobile show and abandoned it, and the Automobile Club of California had considered it and decided to leave it alone, the California Women's Automobile Club resolved to accept the responsibility of a public exhibition the first week in March. As last year, the Coliseum will be the scene of the automobile display.

In connection with the show there will be two automobile parades under the guidance of the Automobile Club of California. Among other outdoor events are a hill climbing contest for runabouts to the summit of Buena Vista Heights, the entire course being visible from the Coliseum; on Wednesday, March 4, there will be a touring car competition over the same course, and on the following day a free-for-all motorcycle race on the hill.

Although dealers have been divided on the advisability of holding a show, the following makes of cars will be represented: Acme, Aerocar, Auburn, Chadwick, Dragon, Elmore, Frayer-Miller, Gale, Glide, Jackson, Locomobile, Marmon, Matheson, Maxwell, National, Overland, Pennsylvania, Renault, Stearns, Stevens-Duryea, Tourist and Winton. Motor boats, airships and a full line of accessories will also be exhibited at the women's first San Francisco auto show.

# AUTOMOBILE HUB BALL BEARINGS\*

By HENRY HESS, MEMBER SOCIETY OF AUTOMOBILE ENGINEERS.

THIS is an account of certain experiments undertaken to determine the behavior of ball bearings as used in an automobile hub under proper and improper conditions.

**The Bearing.**—The bearing selected for test is of the well-known Hess-Bright type, having two-point contact, races of uniform cross-section, *i. e.*, uninterrupted by any filling opening, and with elastic, individual separators interposed between

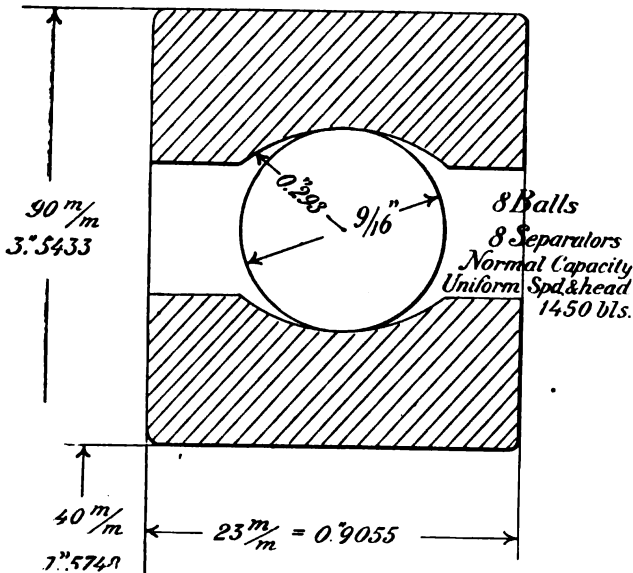

Fig. 1.—Dimensions of ball bearing employed for test.

Editor's Note.—Through a draughtsman's error the explanation reads "spd and head" instead of "speed and load."

the balls. The size is that known as No. 308; its dimensions are given in Fig. 1. This is a size very widely used in the hubs of automobile touring cars.

**Use Conditions.**—In a hub the load will be purely radial, *i. e.*, at right angles to the axis when the car is going straight ahead. When rounding curves or weaving from side to side an end thrust, parallel to the axis, will be imposed in addition. Properly mounted and taken care of, the bearing will be amply lubricated and kept free of rust and grit.

**Test Conditions.**—Test conditions were arranged to conform, as nearly as might be, to the proper and improper conditions that would be found in actual use. They, therefore, embraced:

- (I) Radial loads only.
- (II and III) Combined radial and thrust loads; and
- (IV) Thrust loads only.

The latter condition is not likely to obtain in a hub or axle, but is of interest, as the question of behavior under that condition is often raised.

Test runs with (A) copious lubrication, (B) practically no lubrication, (C) with rust, and (D) with grit, were repeated under each load condition. The loads ranged from a low load as compared with the capacity of the bearing to a very decided overload. The radial load started at 600 pounds and was raised by 200-pound increments to 2,000 pounds. The thrust loads ranged from 50 pounds to 400 pounds by 50-pound increments. The speed was taken at 300 r. p. m., this corresponding approximately to thirty miles per hour of a car. Copious lubrication was provided by allowing the bearing to dip into a relatively large reservoir of oil, so that the bottom balls were carried through that. For dry run-

ning the bearing was rinsed out in gasoline and then dried out in an air blast; this left a very slight oil film, not perceptible to the touch, but nevertheless present. After this test the bearing was rusted in water until a light coat was deposited on all surfaces. Owing to the high finish of the balls and races the rust film on these was not thick; on the separators, which are not polished, the rust was much heavier and interfered decidedly with their elastic action. Grit was provided by throwing sharp building sand between the races.

**Comparative Results.**—The measured friction coefficient may safely be taken as an index of the running under each condition. It is certain that a low coefficient means favorable running and long life, while an increase in the friction indicates an adverse development.

**The Apparatus.**—The machine employed is a special friction measuring machine, capable of definitely measuring the force of the frictional resistance due to radial loads up to 15,000 pounds, of thrust loads up to 10,500 pounds, and of combined radial and thrust loads in any ratio within these limits, and at speeds ranging from 200 to 2,000 r. p. m. The radial load is applied to the bearing under test by a system of weighing beams through a tension rod that is jointed near the test bearing. The friction of the bearing swings the joint to one side by an amount depending upon the frictional force. This movement is small, but measurable by a microscope and within a negligible error. The thrust load is applied by a second system of weighing levers through a small wire of high elastic limit attached to a yoke resting against the outer race of the bearing. The friction tends to rotate this yoke. This tendency is resisted by a delicate set of scales, an error of observation of not over half of 1 per cent. is had without involving particular nicety of manipulation. The principle of the machine as to the radial friction

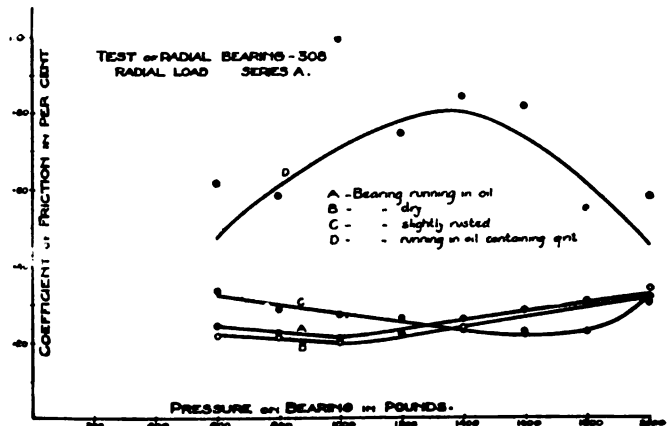

Fig. 2.—Test of bearings under radial loads only.

and measuring features is due to Professor Stribeck, of the Technical Laboratories, near Berlin, extended, however, to give the ability of applying loads about ten times as great while realizing greater accuracy of measurement and convenience of handling. The arrangement for thrust loading and thrust friction measurement is original.

**Plotted Results.**—A diagram of the observed friction coefficients is devoted to each series, I to IV, and each is given a curve, laid through the observed points of the runs made with the bearing lubricated (A), dry (B), rusted (C), and grit (D).

In Fig. 2, the bearing was run under Radial Loads Only. The friction (always referred to the bore of the bearing in

\*Paper read before the Society of Automobile Engineers.

order to permit of ready comparison with the friction that occurs in plain journals at the bore or shaft surfaces) ranges from 0.21 to 0.25 under copious lubrication (A). The Dry Running curve (B) is parallel, and, curiously, lies about 10 per cent. lower. The difference represents not the difference in bearing friction, but that of the relative resistance of the copious oil supply and the slight film left after the oil was washed out in gasoline. It would not do to conclude that this justifies the cutting out of oil, as is not infrequently advised; aside from other considerations, oil, and plenty of it, is necessary as a rust preventive.

Curve C, with the Bearing Rusted, shows at first about 50 per cent. increase in friction, and then, very surprisingly, a gradual drop, curving down to the best values of A and B; but toward the close rising again sharply. An examination of the races involved shows that the initial higher friction was due to the rust, that, as this was worn off, the friction dropped and that the roughing due to the rust having destroyed the high polish and the truth of the ball and race surfaces was attended by an increasing breakdown of these surfaces, as indicated by the final fast rise of the friction. Prolonged running would undoubtedly have confirmed the road experience of the very serious influence of rust on bearing life and endurance.

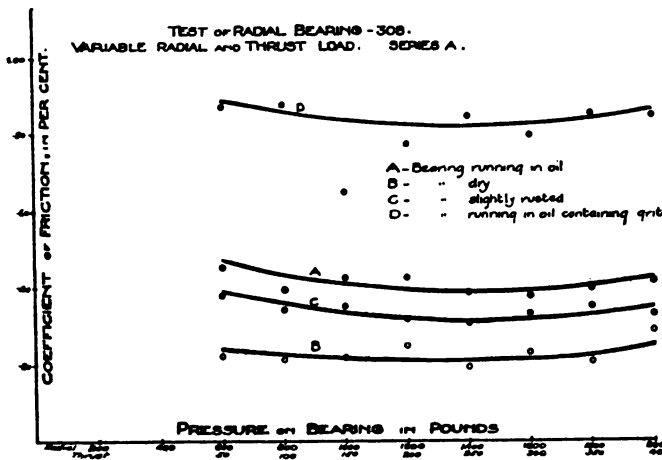

Fig. 3.—Friction under combined radial and thrust loads, increasing simultaneously.

As was to be expected, the insertion of grit raised the friction very decidedly. The readings varied widely, so that the average curve D will be seen to lie quite far from some of the points. As the run was started with the lower loads, and as it took some time to bring about an even distribution of the crudely inserted grit, the friction rose as the grit involved more of the surfaces; the drop after that is accounted for by the gradual working out of the grit and to the grits being worked down and partially destroyed by the wearing action of the balls. In an automobile hub the grit would be more serious since it could not readily escape. The friction due to grit and rust tends to draw the end plates and separators under the balls, and as these two destructive agents wear down the parts the separators may be, and occasionally are, drawn under the balls. That means a destruction of the separators, while the violent wedging also occasionally causes the outer race to be split.

Fig. 3 gives the friction of the bearing carrying simultaneous radial and thrust loads, increasing simultaneously. A comparison of values under the condition of good lubrication, A, between Figs. 2 and 3, shows that a thrust load of one-quarter of the simultaneous radial load about doubles the total frictional resistance, and that, as there is no pronounced upward trend within the load limits advocated, such combined loading is good practice. The curves of Fig. 4 for a constant radial load of 800 pounds, and a variable thrust

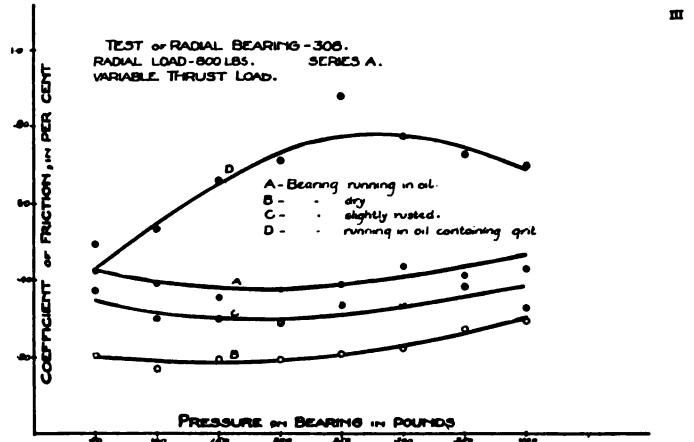

Fig. 4.—Constant radial load of 800 pounds and variable thrust load of 50 to 400 pounds.

load of from 50 to 400 pounds, confirm the deductions drawn from Fig. 3. The advisability of submitting this two-point type of radial bearing to thrust loads has been frequently questioned, and occasionally even the admissibility of doing that has been denied.

Fig. 5 gives a series of curves showing the friction in the conditions A, B, C and D. It will be seen that in every case the friction falls with an increase of load. It is generally reasoned that under thrust the balls must wedge between the curve races. Were that true, then the friction should not only be high, but, even though not equally high under all loads, certainly not decreasing under increasing loads. The curves bear out my reason in explanation. We know, of course, that under load there will be a deformation of the shape of balls and races, and that the theoretical point contact is actually a surface contact of small area. I assume that this surface has an average inclination which gives a blunter wedge than the geometrical angle of the theoretical point contacts. In Figs. 6 and 7, I have tried to show that Fig. 6 gives the wedge angle (b) for the theoretical contact point (a), with a thrust load applied to the race in the direction of the arrow. Fig. 7 shows the surface of deformation (d), with the larger wedge angle (e). As the load increases the deformation must increase; an increasing bluntness of the wedge angle with increasing load should therefore be accompanied by a decreasing frictional coefficient. This reasoning is confirmed by the trend of the curves of Fig. 5. Also, it has been observed that the thrust-carrying capacity of the heavy type of radial bearing is relatively less than that of the medium and light types. Now the heavy type has much larger balls and these will conse-

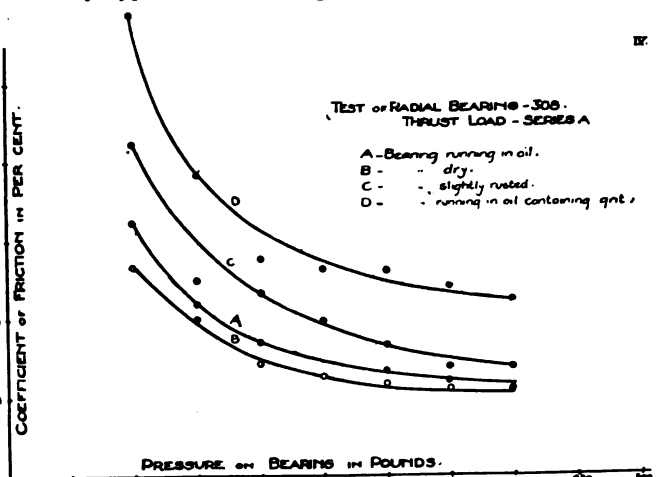

Fig. 5.—Results of constant radial load with variable thrust loads.



quently deform less under heavy loads; that means a smaller change from the theoretical wedge angle, and, therefore, a relatively greater friction; so that this observed fact may be taken in further confirmation of my reasoning.

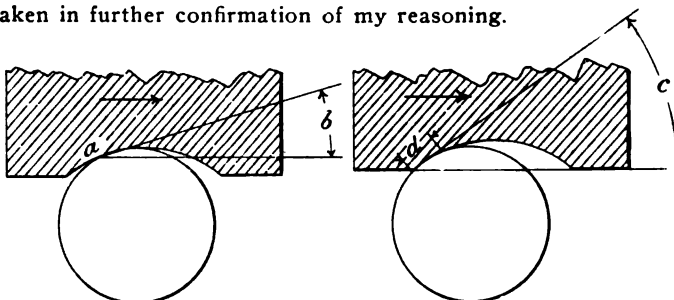

Fig. 6.—Wedge angle with thrust load.

Fig. 7.—Deformation with large wedge angle.

**General Deductions.**—1. The two-point, annular, uninterrupted race ball bearing with elastic separators is efficient and durable under the legitimate conditions of work imposed on it in an automobile hub, which are not unusually severe.

2. Simultaneous radial and thrust loading is permissible and does not result in a material increase of friction as compared with radial loading only.

3. The bearing should be copiously lubricated; easiest running will be had with the least viscous lubricant; that, however, must not be so light as to escape readily, but must be retained by the mechanical arrangement of the hub.

4. Rust must be rigidly excluded, as it will result in breakdown of the bearing surfaces and of the carrying capacity.

5. Grit must be rigidly excluded, as it will result in a wearing away by grinding of the balls and races.

6. As between rust and grit, the former is the more dangerous, since it involves the destruction of carrying capacity, while grit merely brings about a faster wear than is desirable. Rust and grit are nearly always found associated, as the conditions admitting the one generally admit the other. Their combined influence is decidedly bad. Fortunately, both can be kept out by means which are available, simple and easily applied at small expense to automobile hub construction.

## HORSE KILLS 3,900, MAIMS 19,500 YEARLY IN FRANCE

PARIS, Feb. 17.—Being the latest form of locomotion, auto accidents are emphasized in the press to such an extent that the average individual has a firm belief that the auto is the most deadly of all road vehicles. To such an extent has the belief grown in France, that automobile clubs throughout

horses and 250 injured in one year, without a single automobile accident occurring. Translated, the poster reads:

The truth about transportation accidents. Statistics of the Department of the Sarthe from October 1, 1907, to January 31, 1908 (four months):

Horses.	Automobile.
Number of accidents..... 89	Number of accidents..... 5
Number of deaths..... 15	Number of deaths..... None
Number of injured..... 84	Number of injured..... 5

Note.—The detailed accounts of all these accidents, registered according to commune and date, are at the disposition of the public every day except Sunday from 9 till noon, and from 2 to 7, at the Secretarial offices of the Automobile Club of Sarthe, 7 Boulevard Rene-Lavasseur, Le Mans. G. Durand, Secretary.

During 1906, the year in which the Grand Prix of the Automobile Club of France was run on the Sarthe circuit, there was not a single fatal automobile accident in the Sarthe.

Each year the horse kills an average of 50 persons and seriously injures more than 250 in this département.

The Department of the Sarthe having 58,000 horses out of a total of 4,521,000, horse transportation is therefore responsible, in the whole of France, for the frightful average and annual hecatomb of 3,900 persons killed, 19,500 injured.

# LA VERITE

## ACCIDENTS DE LA LOCOMOTION STATISTIQUE

Du Département de la Sarthe  
Du 1<sup>er</sup> OCTOBRE 1907, au 31 janvier 1908  
(4 MOIS)

CHEVAL	AUTOMOBILE
Nombre d'accidents..... 89	Nombre d'accidents..... 5
Nombre de MORTS..... 15	Nombre de MORTS..... Néant
Nombre de blessés..... 84	Nombre de blessés..... 5

Notes: — Les détails de tous ces accidents, enregistrés par commune et par date, sont à la disposition du public tous les jours, sauf le dimanche, de 9 heures à midi et de 2 heures à 7 heures, au Secrétariat de l'Automobile-Club de la Sarthe, 7, Boulevard René-Lavasseur, Le Mans. Le Secrétaire Général: G. DURAND.

<p><b>En 1906</b> Année pendant laquelle le Grand-Prix de l'A.C.F. s'est disputé sur le Circuit de la Sarthe. Il n'y a pas eu dans la Sarthe <b>UN SEUL ACCIDENT MORTEL D'AUTOMOBILE</b></p>	<p><b>Chaque Année</b> <b>LE CHEVAL</b> <b>Y tue en moyenne 50 Personnes</b> <b>Blesse grièvement plus de 250</b></p>
--	---

Le Département de la Sarthe comptant 58,000 chevaux, pour un total de 4,521,000

## La LOCOMOTION HIPPIOMOBILE

A donc à son actif, pour la France entière,  
l'effrayante hecatombe annuelle et moyenne de  
**3.900 MORTS! 19.500 BLESSÉS!**

the country have set themselves the task of obtaining and publishing complete statistics in every district. The Automobile Club of Sarthe, the first to take up the work, has published broadcast the accompanying poster, from which it is seen that in an automobile racing district 50 people were killed by

## THE NEWS FROM GERMANY.

BERLIN, Feb. 28.—The German Crown Prince has been enrolled at the Technical High School, Berlin, for a series of courses in machine building and will also devote attention to motor mechanics. He will be the first of his race who has chosen to be initiated into technical matters, although all members of the Hohenzollern family learn some profession.

His Majesty, the German Emperor, held a reception on February 12 for the autoists chiefly interested in the new Taunus track project, which was attended by several members of the government as well. Herr von Friedlaender-Field discoursed on the various track proposals, guided by plans, but the Taunus received the chief share of Imperial favor, and it is therefore safe to say that it will be put through as soon as possible, when funds will also be forthcoming. The track would commence between Gravenwiesbach and Brandobendorf and finish up at Oberinsel between the Saalbury and Holemartz.

The three Opel cars destined for the Grand Prix are now being tested and are doing well. Fritz Opel has achieved an average speed of 145 kilometers on his car in spite of bad roads. They were originally equipped with detachable wheels, but owing to the race regulations these have been done away with and dismountable rims put in their stead.

## LETTERS INTERESTING AND INSTRUCTIVE

### MORE ABOUT BRAKING WITH THE MOTOR.

Editor THE AUTOMOBILE:

[1,204.]—I have been much interested in following the different articles in your paper which have appeared from time to time on the subject of using the engine for the purpose of braking the car on steep grades, and more particularly in the article of C. F. Redden, in your issue of February 20. I have followed the discussion very closely, but from all that I can gather there appear to be several inconsistencies in the directions as given by the several writers on the subject. In this article of Mr. Redden's, for instance, he states "In braking the car by means of the engine the greatest care must be used, and the car itself and the motor should be as nearly at the same speed as possible," while just above that he says "that the electric current should be switched off." Now I have driven a car for three years, and at present have a "30," but in all that time I am unable to locate a single instance where on coming to the top of a descent and cutting out the ignition my engine failed to come to a complete stop, then if the gears were shifted it would, of course, necessitate the letting in of the clutch and engaging the engine from a standstill, thereby causing quite a shock to the entire transmission in so doing. I take it, of course, that Mr. Redden means to change the gears and engage the clutch, cutting out the electricity, but his article does not make that point clear.

But the point on which I would like to have some clear information is this. I find in practice that on almost any ordinary grade I can hold my car down to a perfectly safe speed by simply closing the throttle tight, and I do not find that it makes any appreciable difference to cut out the ignition at the same time, nor can I see any logical reason why it should. It is a fact that with the car standing still and the engine running free that by closing the throttle entirely the engine will at once come to a stop. Now if that is the case, what is the use of cutting out the ignition when coming down a grade and using the engine to brake the car? If the engine will not run with the throttle closed when standing still why does it not give the same resistance on a down grade as it would if the ignition was cut out? I find in practice that on the majority of grades as found in running over the country that by the time the ignition is cut out and the car brought under control that the bottom of the grade is so nearly reached that one wants to withdraw the clutch and let the car run free for a time and then, of course, with the ignition cut out the engine at once comes to a standstill, then on again letting the clutch engage you have the unpleasant experience of a sudden jar to the whole transmission to start the engine, and the only way to avoid that is to wait until the car comes to almost a complete standstill, which is something that one does not like to do, especially if in the least hurry, or trying to make time.

But I would like very much to have some one explain just what the difference in braking power would be from the engine under the two different sets of conditions, viz., running with the throttle entirely closed and the ignition on, or running with the same conditions and the ignition cut out.

Any information on this point will be greatly appreciated in your "Letters Interesting and Instructive."

Richfield Springs, N. Y.

C. B. CONRAD.

If it be possible to bring the motor to a stop by closing the throttle when running free, the only thing to be accomplished by cutting out the ignition in coasting would be economy of current, in case a battery is employed as the source of current. The fact that a spark was occurring in the cylinder could have no effect whatever on the braking power of the motor when used in this manner, provided that the throttle closed sufficiently to prevent the inspiration of sufficient fuel to cause an explosion. Where the motor is to be used as an auxiliary brake on a long, steep descent, and it is valuable for this purpose to relieve the running brakes, we should recommend dropping into a low gear before getting over the brink of the hill, and then simply closing the throttle, as you state is your custom. On ordinary grades, it would scarcely be necessary to drop from high-gear, as the resistance of the latter would be sufficient for all ordinary purposes. Much less strain is put upon the motor by leaving the ignition current on, and gradually opening the throttle at the bottom of the hill, than would be the case where the throttle is left even partly open, and then the current is switched on. Many drivers, however, merely cut out the ignition.

### HOESPOWER AND VALVE-TIMING OF MOTOR.

Editor THE AUTOMOBILE:

[1,205.]—Will you kindly answer the following questions, which I am particularly interested in?

1. How many horsepower will a four-cylinder marine motor develop at 600 r.p.m., with a bore of 5.5-8 by a 6-inch stroke, and state what formula you have used and if the same can be used in rating automobile motors?

2. How much lead should the valves of this marine motor have and compare the same with the valves of a high-speed motor?

Chicago, Ill.

AUTO ENTHUSIAST.

1.—The indicated horsepower of the motor in question would be 23.04, the formula employed being as follows:

$$I. H. P. = \frac{D^2 \times L \times R \times N}{18,000} \text{ in which}$$

$D$  = diameter of the cylinder in inches;

$L$  = length of the stroke in inches;

$R$  = number of revolutions per minute;

$N$  = number of cylinders.

The denominator is a constant, calculated on the assumption that gasoline is to be employed as the fuel, and is given by Roberts. This formula is equally applicable to calculating the I. H. P. of automobile motors.

2.—The exhaust valve should begin to open at a point 18 to 20 degrees on the crank circle in advance of the lower dead center, closing when crank has just passed dead center, or 1 to 2 degrees. The opening of the inlet valve corresponds to the latter point and it remains open until the crank has passed the lower dead center, about 10 to 15 degrees. In a high-speed motor, running at 1,200 r.p.m., these factors would be increased to 30 to 35 degrees in the case of the exhaust, and 20 to 25 degrees in the case of the inlet, but it will be found that no arbitrary figures can be taken as a standard in this respect, automobile designers having departed almost universally from former standards by greatly increasing the valve diameter, which permits of leaving the valve closed a proportionately greater part of the stroke. With the small valves formerly used, the lift would be too great to make a high-speed motor either durable or silent, as the hammering would be excessive. Consequently, the valves have been made very large in order to permit of employing a minimum lift, and on the latter will naturally depend the amount of lead required in every case.

### EFFECT OF LENGTHENING THE STROKE.

Editor THE AUTOMOBILE:

[1,206.]—Will you kindly answer the following questions? Does the length of the stroke of a gasoline engine make any difference in the power developed? It would seem that it does not by the A. L. A. M. formula, although a great many other formulæ make use of it in computing the horsepower of a motor.

South Norwalk, Conn.

RUSSELL FROST, JR.

Both the power and the efficiency of an internal combustion motor are increased by lengthening the stroke, for the reason that the power created comes entirely from the expansion of gases raised to a high temperature and pressure by their rapid combustion, or explosion, as it is usually termed, though this is somewhat erroneous. As is well known, this pressure is extremely high at the moment of ignition, as shown by the almost vertical line of indicator cards, and the drop is likewise extremely rapid, as is evident from the form of a gas engine indicator card when compared with the sustained pressure line of a steam engine. As this pressure is the sole source of power, it will be evident that the greater proportion of it that is utilized, the greater will be the power developed per unit of fuel. To do this the stroke has to be lengthened in order to allow the hot gases to expand down to as near the atmospheric point as practical with an effi-

cient exhaust. It is common in stationary gas engine practice to make the stroke twice the diameter of the bore, but it is impracticable to increase the stroke of an automobile engine for the reason that the weight rises very rapidly with an increase in the stroke, and but little proportionately with an increase in the bore. Hence, the stroke seldom exceeds the bore more than a fraction of an inch, as the gain in power and efficiency is a negligible factor compared with the importance of keeping the weight down.

The A. L. A. M. formula does not take any account of varying lengths of stroke, for the simple reason that it is merely intended as a formula for "popular consumption," so to speak, and is only designed to give approximate results that may readily be calculated by anyone. To accurately compute the indicated horsepower of a motor a number of factors that do not appear in this formula must be employed. It is based on standards adopted from the characteristics of a number of American motors, and, as already mentioned, is merely an arbitrary rule for easy figuring.

### EQUIPMENT OF NEW YORK-PARIS TOURISTS.

Editor THE AUTOMOBILE:

[1,207.]—Will you kindly, through "Letters Interesting and Instructive," let me know what comprises a Nansen kitchen and where it can be purchased. Also what make of windlass was carried by the De Dion auto in the New York-Paris run, as described in the last issue of "The Automobile."

Perth Amboy, N. J.

G. W. TYRRELL, M.D.

The type of cooking stove to be used by the De Dion crew in the run to Paris is the development of one employed by Nansen in his Arctic explorations, and known in a general way as a Nansen kitchen. The stove uses kerosene under pressure as fuel, by means of a Primus burner without wick. Experiments have proved that kerosene is the only suitable fuel for this class of work, alcohol being entirely too bulky. The vessels connected with the kitchen are all of a special aluminum alloy comprising copper and nickel. This gives minimum weight and a metal which will not burn out under the greatest heat obtainable from the stove. As it is supposed that water will never be available, frozen snow being used in its stead, this is an important feature. These outfits are procurable from high-grade sporting goods dealers in New York City.

The De Dion car was fitted with a small capstan, not a windlass. It was mounted on a stout board and carried when not in use on the running board of the car. When required to be brought into operation it could readily be mounted on the forward end of the frame in front of the radiator. We do not know the name of the maker of the capstan, the features of which were smallness, low gearing and operation by a lever transmitting power on both upward and downward strokes.

### HOW CAN THIS LINING BE RENEWED?

Editor THE AUTOMOBILE:

[1,208.]—The folding top of my car is Pantasote, lined with a dark cloth like broadcloth—vulcanized on. The outside is in good condition, but the inside cloth lining has faded to a dark purple. Can you tell me if there is any known method of dyeing the cloth lining—while attached to the wires—either with a brush, sponge, or other method, or whether there is any way to restore the color or otherwise make the lining presentable? GEORGE A. FAY.

Meriden, Conn.

While we must confess ignorance as to exactly the method to be pursued in making such a renewal, owing to lack of experience, we should advise sending the top to the manufacturer, as we do not believe it is a job at which an amateur would shine to any great extent. If there be any manner of doing this without removing the old lining, which we doubt, probably some manufacturer of tops will come to our assistance and tell how it can be done to the best advantage, and his letter will be reproduced in this column.

### METHOD OF HARDENING CAM FACES.

Editor THE AUTOMOBILE:

[1,209.]—Will you kindly advise me, through your valuable paper, the best way to harden cams? W. E. GARRABRANT.  
Dallas, Tex.

The process employed for this purpose is known as "cementing" or "case hardening," and it requires the facilities of a well-equipped shop to perform properly. The parts are packed in iron boxes with carbon, and then brought to a determined temperature, at which they are maintained constantly for a number of hours, depending upon how deep the carbon is desired to penetrate the metal. This process causes more or less distortion of the parts, so that they are only machine finished before being subjected to it, being subsequently accurately finished by grinding. Where there are no facilities for such work at hand, cams may be roughly hardened by tempering, as soft steel, no matter how low in carbon, will harden to a certain extent, when brought to a red heat and then plunged into water. Using brine will increase the hardening effect slightly.

### WHO CAN ANSWER THIS DEFINITELY?

Editor THE AUTOMOBILE:

[1,210.]—Would it be asking too much of you to tell us whether you know of any marine engine builders who abandoned four-cycle engines for the two-cycle? Any information you might give us on the subject would be greatly appreciated. PUGH BROS.  
Providence, R. I.

We do not know of any such instance, and thought the fact was quite to the contrary, the two-cycle engine having been given up in the majority of instances where extreme speed was aimed at, as in most of the high-powered racing boats. As many motor boat enthusiasts are numbered among the subscribers of THE AUTOMOBILE, doubtless some of them may be able to supply the information desired, or at least more than we are able to furnish.

### MORE ABOUT A MOTOR'S IMPULSE BALANCE.

Editor THE AUTOMOBILE:

[1,211.]—I beg to disagree with your answer to letter No. 1,188, January 30 issue, "Balance of Four and Two-cycle Engines." With cranks at 180 degrees, I claim it is impossible for No. 3 cylinder to be balanced by compression stroke of No. 2 cylinder, as you state in your letter. It looks to me as though No. 2 might be on the suction stroke about that time and No. 4 on compression. O. H. COLWELL.  
Providence, R. I.

You are quite right; cranks numbers two and three, being in the same plane, always move together and naturally could not balance one another. It should have read number *four*, which, as you state, would be on the compression stroke.

### WANTED: VIEWS OF OTHERS ON LUBRICATION.

Editor THE AUTOMOBILE:

[1,212.]—I was very much interested in communication No. 1,181, in "Letters Interesting and Instructive," concerning experience in lubricating the Ford engine, as mentioned therein. I have had considerable trouble myself; however, it was voluntary, inasmuch as while my car was new I desired to keep it flooded with oil so that there would be no chance of any cutting going on in the cylinders. I must admit that the idea of mixing oil, kerosene, and radium decarbonizer, and using this as a mixture for the crankcase would seem rather queer. As near as I can judge, kerosene cuts lubricating oil and destroys its lubricating qualities, and again the radium decarbonizer I take to be very much the same thing, and probably if anything it acts more strongly than the kerosene. This I do not know from experience, but I am under this impression. It would seem to me, therefore, that the fact that this correspondent's engine does not give trouble is probably owing to the great volume of the mixture. The writer has found that by using a rather light grade of oil, in a fairly liberal manner, say 40 drops per minute, has given him fine satisfaction and no trouble.

I should like very much to have the views of some other owners in reference to letter No. 1,181, as, of course, if this really does give satisfactory results in every way, including thorough lubrication of the engine, it would certainly be a good thing to know.

Philadelphia, Pa.

W. S. HEAGAMAN.

# IN THE BEGINNING OF AMERICAN AUTOMOBILING

By CHARLES E. DURYEY.

THE first automobile racing event in America was due to the initiative and generosity of H. H. Kohlsaat, then proprietor of the *Times-Herald*, of Chicago. He was impressed by the showing in the great French event of the spring of 1895, and in June announced a series of prizes amounting to \$5,000 and a small gold medal, to be given to the most meritorious in a three-day auto event, to be held about November 1, 1895. The matter was kept alive in the columns of his paper and public interest stimulated as much as possible so as to attract a large entry list. A prize was offered for the best name for the new vehicle and after much deliberation "motocycle" was adopted. The fate of the word has proven how little the committee understood either horseless carriages or the automobile vocabulary.

Inventors sprang up like weeds in many small places, and each was sure he had the device that would get the big prize or at least one of the small ones. Eighty-three entries were secured, some entrants engaging several vehicles. The *Monitor* was built in ninety days; surely the same American talent was equal to the task of making successful self-propelled carriages in four months. It looked then, as it often has since, very easy to put together a motor and a buggy and take a ride. But, alas, there were some disappointed inventors and discouraged event-promoters when the time arrived and but three or four vehicles were on hand. Pennington, of airship and other hot-air fame; Mueller, who had imported a Benz rig; Duryea and one or two others constituted the small group. The others were keeping the wires hot explaining that they were almost ready, etc., etc.

## How the First Race Was Lost.

The management saw nothing else to do but postpone, and this they did, naming Thanksgiving day as the next date. To console those present and recompense them somewhat, an exhibition run of fifty-odd miles over the course was held for a purse of \$500 to be divided equally among those who covered the course regardless of speed or time so long as it was in the same day. We could feel our half of that money bulging our pocket, for there was no real auto there that could cover that course in opposition to the Duryea, except the Mueller-Benz. It seemed so certain that the Duryea rig, which had been used by a green promoter all summer and had never been towed, would gambol over those fifty-odd miles on that beautiful Fall day in a most easy, pleasant manner, that my brother and I rode away with as much enthusiasm as a couple of school boys. We had a few spares and there did not seem to be anything likely to break that could not be repaired by either or both of us on the road if necessary. We ran away from the Benz and were going finely when our chain broke. This did not worry us, though it permitted the Benz to get ahead. We were soon after them and rapidly overhauling

a German farmer driving a light road cart. There was ample room to pass him on the left, as was our duty according to law, but we sounded our warning to let him know we were coming. This ruined us, as these legal warnings have often done since. He looked around and seeing us coming "like a railroad train" (about 12 miles per hour) decided he must get out of the way, so he took a short hold on the lines and pulled the outfit across the road to the left. This blocked our way, and rather than hit him we glided into the ditch which looked easy, being full of grass. Our front wheels dropped nearly out of sight and both hubs gave way. The Benz got all the money; the Duryea all the disappointments.

The Duryea went to the factory by freight; but was again present on Thanksgiving day. Chicago was in the grip of a blizzard. Trains were late or abandoned. Pedestrians sank

to the waist in some of the streets. Lincoln Park had not been traversed when the contestant's entered it. There were more entries, however, than on the first occasion. A show room at Sixteenth street and Wabash avenue served as headquarters, and as the streets became more passable, some demonstrations were given. Haynes had his second vehicle there. Morris & Salom had two electrics, which were the first of the long series of the Electric Vehicle Company. Lewis had a friction drive which he very carefully guarded. It was the predecessor of the Searchmont. In all there were eleven who took starting numbers. The weather had moderated enough to soften the snow on top but at night this froze into a crust hard enough to support pedestrians and sleighs. The next morning was snappy cold. A starting spot had been scraped free of snow in Jackson Park. Some of the starters arrived on trucks, some under tow and some, like the Haynes, did not arrive. Only five lined up. The Duryea had run out without trouble



Charles E. Duryea and His Brother, J. Frank Duryea.

The car shown is the one which won the *Times-Herald* race of 1895, the first automobile race ever held in the United States. Charles E. Duryea is the pioneer of the American industry in this country, and J. Frank Duryea is the designer of the Stevens-Duryea car.

and seemed to be a good road breaker so it was sent off first. The others followed quickly, but as they came to the slight rise leading on to the old Midway Plaisance it was noticed that there was trouble. A run to the spot showed all but the Duryea stalled in the snow. Salom voiced the common sentiment when he said "It's against the rules to be pushed, but you had better lend us a hand, boys." So they were pushed and not only once but many times during the day.

## Few Starters, Fewer Finishers in First American Race.

The course lay through the city and to the north, then back to the city and out northwest, then back to the start through the parks on the west side. Total distance 54 miles. The electrics were quickly out of it. The Macy Roger, a French rig, made a hard fight and covered probably forty miles. The Benz operator fainted from exhaustion but the rig was driven in by Chas. B. King, now of the Northern, and abandoned at the finish line. The Duryea had two small breakdowns,



one of which was distinctly traceable to the original accident, but in spite of the delay caused by these, it won the contest. Its operator drove back to the storeroom with no sense of physical exhaustion. It was the only rig to cover the course and transport itself both from and to its quarters on the same day. Total distance about 70 miles. Many modern rigs with their small wheels could not do such a feat. The first prize, \$2,000 cash, was awarded to the Duryea, which for years was the only American rig that had proven able to defeat foreign-built vehicles. That this was not accidental, but a reality, was amply shown by other Duryea rigs winning the second American event at New York the next spring and by running away from the French victors of '96, in the Liberty Day run at London, on November 14, 1896.

The effect of this contest on the budding industry was peculiar. The inventors found themselves not ready even for the New York event, and many of them fell out, surprised at the severity of the problem and disgusted with its difficulties. The carriage makers came expecting to see carriages with a push-button on the seat and a door-bell battery under it. They found a whole power plant and went away convinced that it would never do for their trade. The cycle user could only see steel wheels and rubber tires, and condemned all else,

and later got his fill of toys in the shape of the little steamers which he snapped at so eagerly when they were thrown on the market. The public generally were disappointed at the slow time made (because of the snow and the accidents, about 8 miles per hour), and ridiculed the performance and the promoters. The few thinking ones saw that it had answered for ever the question "What will they do in winter?" and had proven superiority over the horse. It had also confirmed the gasoline men's claims as to the superiority of gasoline motors for this work and those willing to see did not need another lesson.

Twelve years later we see the motor buggy just getting a very tardy recognition of its merits, and yet we, as a people, pride ourselves that we are up-to-date and can see through a ladder. There was enough in that first run to prove conclusively the value of the buggy type, but few could see it.

That Duryea rig weighed under 1,200 pounds. It had 44 and 48-inch wheels, with 2-inch hosepipe tires. The motor was a two-cylinder, four-cycle, located at the rear. It had three speeds forward and single chain drive to a live rear axle. Why the makers went to France for their models when the public have been all these years waiting for something like this is a question not very easy to answer.

## GRAND PRIX TO BE GREATEST RACE EVER HELD

PARIS, March 1.—One hundred and five automobiles are officially engaged for the two races on the Dieppe course, July 6 and 7. Forty-five of these are entered for the Grand Prix, and 60 for the small voiturette contest on the preceding day. During the last twenty-four hours Brasier, who had been looked upon as doubtful, sent in the official entry of three cars, to be driven by Thery, Baras and Bablot; Itala put in a team of three, and Porthos, a French firm with factories near Paris, entered two cars. The 45 champions are distributed among six nations, France having 20, Germany 9, England 6, Italy 6, Belgium 3 and America 1. The firms represented are:

**FRANCE.**—Panhard (3), Motobloc (3), Dietrich (3), Renault (3), Bayard-Clement (3), Brasier (3), Porthos (2).

**GERMANY.**—Benz (3), Mercedes (3), Opel (3).

**ITALY.**—Fiat (3), Itala (3).

**ENGLAND.**—Austin (3), Weigel (3).

**BELGIUM.**—Germain (3).

**AMERICA.**—Thomas (1).

With the exception of the Italian Isotta-Fraschini team and the Swiss Martini cars, all the contestants in the voiturette race are French. As the ordinary entrance fee for the runabout race is the modest one of \$100 per car, it is quite likely that the already long list will be still further increased by half a dozen late entries at double fee. Most of the firms

engaged in the voiturette race are exclusive builders of small cars, the only exceptions being Isotta-Fraschini, Pilain, Martini and Aries.

In engagement fees the secretary of the Sporting Commission of the French Club has received \$42,800, this sum covering 45 Grand Prix racers, 60 runabouts, 5 tire stations, one oil stand, and a reserve space for the Bosch Magneto Company. The Racing Board income is further increased by the Dieppe subsidy of \$10,000, making already \$52,800. This will, of course, be very largely augmented by advertising spaces on the course and grandstand admissions.

Expenses, however, in connection with a race of such magnitude will be enormous. It is estimated that grandstands and accessories alone will cost from \$20,000 to \$25,000. Over 38,000 yards of fencing have been ordered to protect the course at every cross road and wherever people are likely to congregate, and in addition 9,000 yards of solid wood barricading will be erected. The wooden bridges across the course will be the same as last year, and will be erected at the same places.

It is declared authoritatively in Paris that Kronprinz William will attend the Grand Prix races incognito. The matter is at present in the hands of the ministers of foreign affairs at Paris and Berlin, and appears likely to be brought to a successful termination.

### THOMAS PARIS CHAMPION A STOCK CHASSIS.

It is not the Brighton Beach 24-hour racer which is taking part in the New York to Paris tour as the representative of America, but a stock chassis which had been promised for shipment to the Whitten-Gilmore Company, agents for the Thomas Company in Boston. No car was available, and on request the Boston dealers released this machine.

No changes whatever were made on the chassis, declare the Thomas people, other than a steel bar placed across the frame connecting the two front spring hangers. This was not added to strengthen the car, but to furnish a suitable attachment for a rope, should it at any time become necessary to hoist the car by means of block and tackle. The car had not been run or tested more than other Thomas Flyers.

### MAXIM'S MUFFLING LEADS TO SILENT GUN.

HARTFORD, CONN., March 2.—Hiram Percy Maxim, who has been closely identified with the development of both the electric and the gasoline automobile from their very inception in this country, has just been granted a patent on a silent firearm, the invention of which he attributes to the result of long study of efficient methods of muffling the exhaust of a gasoline motor. The device consists of an automatic valve placed near the muzzle of the gun and which is closed by the pressure of the gases, once the bullet has passed, the remaining gases under pressure then being allowed to escape slowly through small perforations, giving rise to nothing more than a slight hissing, which is not audible more than a very short distance away from the gun.

## A MILLION GRANGERS WANT FEDERAL ROADS AID

CONCORD, N. H., Mar. 2.—The National Grange, an organization of farmers in twenty-seven States, with an aggregate membership of nearly one million members, has for a number of years advocated the enactment by Congress of legislation creating a National Highways Commission and making liberal appropriations for the improvement of the public roads. During the past year the grange has perfected plans for conducting a widespread, systematic, educational campaign for the purpose of showing the urgent necessity for the adoption of a broad, comprehensive policy of public highway improvement by the various township, county and State authorities, and to induce the National Government to lend its assistance to a movement intended to secure the establishment of a complete system of properly constructed roads in all sections of the country.

It is contended by the members of the grange that the improvement of our highways is as equally deserving of Federal appropriations as is the improvement of our waterways, and that the work of the proposed National Highways Commission would greatly stimulate the construction of better roads by the various States, counties and townships. The splendid road system of France, admitted to be the best in the world, is declared to be due chiefly to the road policy of the French National Government, under which a corps of highly trained engineers plan and direct the work of constructing and maintaining the principal roads of that country.

The deplorable condition of most of the roads in the United States, probably the worst in any civilized country, is generally recognized, and it is urged by the grange that it is high time that action should be taken by the National Government to bring order out of the existing chaotic conditions and substitute a scientific policy of road construction and improvement for the haphazard methods which now prevail to so large an extent.

The following resolutions unanimously adopted by the National Grange give the point of view from which the farmers regard the question of Federal aid to public road improvement:

Whereas, The improvement of the highways of the country is a matter of general public concern, and should properly receive the attention and assistance of the National Government, and

Whereas, The revenue raised by taxes paid by the people of the country as a whole should be devoted as far as possible to purposes which will benefit the greater number of the taxpayers in all sections of the country, and

Whereas, No argument can be advanced in favor of the annual appropriations by Congress on behalf of river and harbor improvements that does not apply even more strongly to the improvement of our public roads; therefore,

Resolved, That the National Grange favors a general policy of good roads construction by the various municipalities, counties and States, and

Resolved, That we favor the immediate enactment of legislation by Congress making liberal Federal appropriations for the improve-

ment of the public highways of the country, these appropriations to be expenses in such manner as Congress may prescribe.

House Bill 15837, introduced in Congress on January 30, 1908, by the Hon. Frank D. Currier, of New Hampshire, embodies the principle of creating a National Highways Commission and of Federal aid for public road improvement, unanimously approved by the National Grange at successive annual conventions and was carefully drawn to meet objections raised against previous bills for the same purpose.

By decisions of the Supreme Court of the United States it is held that the National Government has power to construct, maintain or improve roads in the various States used in interstate commerce, and all roads leading to or connecting therewith. It is therefore practicable under this bill for the proposed highways commission to aid in the construction or improvement of any road in any part of the country, since all roads connect with, or lead into, some other road used in interstate commerce.

It is provided in the bill that the commission shall, as far as possible, act in cooperation and consultation with the authorities having charge of the construction and improvement of the public highways of the several States, and in accordance with this provision the distribution of the amounts appropriated will be governed by the wishes of the people of the States, acting through their public road officials. Under this policy there will be no danger of some roads in certain sections of the country receiving more than their fair share of the Federal appropriation, since the people of each State can be relied upon to see that their highway authorities insist on the expenditure of these appropriations for the best interests of the States as a whole.

The bill also provides that not less than \$500,000 out of the total appropriation of \$50,000,000 shall be expended in each State of the United States, this amount to be expended in each State at the rate of not less than \$100,000 annually. This insures the smaller States against discrimination in favor of the larger or more densely populated States, and will prevent anything like favoritism in the distribution.

The enactment of this bill will inaugurate a national policy of road construction and improvement which will ultimately result in giving the entire country a system of permanent public highways, constructed after the most scientific methods under the joint supervision of the National Highways Commission and the various township, county and State authorities. The engineers and construction staff of the commission and the appropriations made by Congress will be available for aiding in the improvement of any roads in any part of the country, and the roads so improved will be a constant inducement to each community to cooperate in making our road system what the wealth and intelligence of our people entitle us to have—the best in the world.

### A Bill to provide for the creation of a National Highways Commission, and for the construction, improvement, and maintenance of public highways.

Be it enacted by the Senate and House of Representatives of the United States of America, in Congress assembled, That this Act shall include within its provisions any and all public highways within the territory of the United States which, in the judgment of the commission hereinafter created and constituted, might be constructed, improved, or maintained to promote interstate commerce and trade and the postal service of the United States.

Sec. 2. That a commission is hereby created to be called the "National Highways Commission," to consist of three commissioners. The President of the United States shall, by and with the advice and consent of the Senate, appoint three commissioners, who shall have a practical knowledge of road building and construction.

Any vacancy which may occur in the commission shall in like manner be filled by the President; and he shall designate one of the commissioners to be president of the commission. Each of the commissioners appointed shall receive as pay and compensation for his services five thousand dollars per annum. The commissioners shall remain in office subject to removal by the President for inefficiency, neglect of duty, or malfeasance in office.

Sec. 3. That it shall be the duty of said commission to take into consideration, formulate, and adopt such plan or plans for the improvement, construction, and maintenance of such public highways, the improvement, construction, and maintenance of which shall, in the judgment of the commission, acting in co-operation and consultation as far as possible with the duly constituted authorities having charge of the construction and improvement of the public highways of the several States, promote and facilitate interstate

commerce and trade and the postal service. The said commission may, prior to the completion of all plans and surveys contemplated by this act, proceed to such immediate work as in the judgment of said commission may constitute a part of the general system of works herein contemplated.

Sec. 4. That it shall be the duty of said commission to superintend and direct such works as are herein contemplated, and to carry into full execution such plan or plans for the construction, maintenance, and improvement of public highways as may be devised and adopted by the commission as herein contemplated, and to make such additional surveys and investigations and mature such additional plan or plans and to carry the same into full execution as may be deemed necessary to construct, improve, and maintain a system of public highways, advantageous for the purposes of interstate commerce and trade and the postal service, and to accomplish the object of this act.

Sec. 5. That the commission herein constituted and appointed may cause proceedings to be instituted in the name of the United States in any court having jurisdiction of such proceedings for the acquitment by condemnation of any land, right of way, or material needed to enable it to maintain, operate, and prosecute works for the construction, maintenance, and improvement of public highways, for which provision has been made herein, and to construct, improve, and maintain such public highways. Such proceedings to be prosecuted in accordance with the laws relating to suits for the condemnation of property for a public purpose of the States wherein the proceedings may be instituted: Provided, however, That when the owner of such land, right of way, or material shall fix a price for the same, which in the opinion of the commission shall be reasonable, the said commission may purchase the same without further delay: And provided further, That the said commission is hereby authorized to accept donations of land, rights of way, or material required for the maintenance and prosecution of such work.

Sec. 6. That there is hereby appropriated, out of any moneys in the Treasury of the United States not otherwise appropriated, for

the purpose of carrying out the provisions and objects of this act the sum of fifty million dollars. The sum of not less than five hundred thousand dollars out of such appropriation shall be expended in each State of the United States, said sum of five hundred thousand dollars to be expended in each State at the rate of not less than one hundred thousand dollars a year. The said appropriation of fifty million dollars to be available at the rate of ten million dollars a year during the years nineteen hundred and eight, nineteen hundred and nine, nineteen hundred and ten, nineteen hundred and eleven, and nineteen hundred and twelve. If any of the appropriation herein made is not expended in the year named that portion not expended shall become available in the succeeding year or until expended.

Sec. 7. That the commission herein created and constituted shall superintend, control, and expend for the purpose of this act all appropriations herein made, or which hereafter may be made for said purposes, or so much thereof as shall be necessary, and shall prepare and submit through the president of the commission, to be by him transmitted to Congress at the beginning of the regular session in December of each year, a full and detailed report of all its proceedings and actions and of all such plans and systems of work as may be devised, in progress, or carried out by it, and of all such additional plans and systems of work as may be devised, matured, and adopted by it, with full detailed estimates of the cost thereof, and a statement of all expenditures made by it; and the Secretary of War may detail from the Corps of Engineers, or other corps of the army, an officer or officers to aid them in their work, who shall serve without additional compensation to that now allowed by law; and all moneys hereby or hereafter appropriated shall be expended under the direction of the Commission in accordance with the plans, specifications, and recommendations formulated, matured, and adopted in accordance with the provisions of this act.

Sec. 8. That this act shall be known as the "National Highways Act," and shall take effect at the expiration of thirty days after its passage by Congress.

## THAT IRIDESCENT DREAM OF A TRANSCONTINENTAL AUTOWAY

INTEREST has been aroused in automobile circles by the movement started by ex-Congressman William J. Coombs, former director of the Union Pacific Railroad and president of the Municipal Art Society of New York, to obtain a general expression of the sentiment of the country in regard to having the United States government build a great transcontinental railway from the Atlantic to the Pacific ocean, on part of which public highway it is also proposed to construct a transcontinental automobile road, extending from ocean to ocean.

Mr. Coombs disclaims any intention to have the government operate the road, but simply to furnish trackage which can be availed of by any existing road or roads to be hereafter constructed, or by any freighter by the payment of tolls and compliance with general regulations. A reason for this movement, as urged by Mr. Coombs, is that there is not available capital enough in the country to provide trackage to meet the growing wants of its commerce.

It has been suggested to Mr. Coombs that the automobile interests of the country were very large, and that this scheme of a great transcontinental railway might be made more attractive, provided that upon this strip of land a great national automobile road could be constructed.

Mr. Coombs says he has had some hesitation in proposing such an automobile road, as it might savor of a bid for the support of particular interests. At the same time, he recognizes the fact that automobiles have come to stay, and that everything that would divert their traffic from the ordinary roads of the country would be of great benefit to the country in general, while the comparatively small amount of land required for the construction of this automobile road would be no hindrance to the construction of the proposed trackage. In fact, in deciding upon the amount of land required, Mr. Coombs had had this in mind. Mr. Coombs goes on to say:

"The use of this automobile road would, of course, be under the same regulations as far as tolls and general man-

agement is concerned as the railroad. Private enterprise would provide for supply stations and hotel accommodations. The variety of country and scenery that would be embraced in a trip across the continent over such a road could not be duplicated in any country in the world. The location of the automobile road upon the strip of land would be upon the edge of it so as not to interfere with the main feature, to wit, the necessities of the railroad. This transcontinental railway could be built by the government much more economically and with less wastage to the resources of the country than by private enterprise. As to the route, after many years of thought on the subject, I have decided that the route which would most effectively serve the greatest interests of the country lies along the parallel of 42 degrees, from the Atlantic to the Pacific ocean, or as near that as the physical conditions would permit. The road would extend across the States of New Jersey, Pennsylvania, Ohio, Indiana, Illinois, Iowa, Missouri, Nebraska, Colorado, Utah, Nevada and California. Under the provision of the constitution providing for postroads and military roads, the government would be authorized to condemn a strip of land approximately one-half mile in width over the whole distance of the main line upon which sufficient trackage could be laid as the wants of the country called for to provide for fast trains, slow trains, and sidings. I would avoid as far as possible the touching of cities where the terminals and right of way would be expensive. As to the extraordinary amount of land that this plan would call for to condemn and the great expense to be incurred, that is a matter of no consideration in view of the great interests involved."

Evidently Mr. Coombs overlooks the fact that railroads derive their support from the country through which they pass as well as the large cities comprising their terminals, though his proposal to avoid cities might be subject to modification, particularly as he states that the cost of carrying out the work is immaterial in view of its importance.

# FEATURES OF THE WORLD'S MOST FAMOUS FLYER

**B**ETWEEN the automobile and the flying machine there is a much more intimate connection than is generally supposed by the public, which sees in the one a means of locomotion over highways and in the other a possibility of securing the conquest of the air. Without the gasoline motor the dirigible balloon would still be an impossibility. But for the same motive power the aeroplane would never have got beyond the stage of the box kite.

Henry Farman, who, like the majority of those at present struggling with the problem of aerial navigation, was an automobilist before he became an aeronaut, has done so much to develop

should thus have a big bearing surface, should be light and should have a rapid rate of travel.

From the accompanying drawings, reproduced from *Omnia*, the general characteristics of the Farman aeroplane are readily perceived. Overall measurements, according to the same review, are 44 feet long, 32 feet wide, 118 inches high, and total weight in running order 1,168 pounds. The flying machine is composed of five distinct parts: the forward frame carrying the motor and pilot, the chassis or supporting frame, the forward plane, the uniting beam, and the rear plane. The forward frame is a kind of wood cradle strengthened with metal stays, the function of which is to carry the motor, the pilot and all operating mechanism.

At the front of the forward frame is what is known as the equilibreur, a double rectangular plane, the angle of which may be varied at the will of the operator. It is by the variation of this angle that the aeroplane is made to rise or descend, as desired. Normally the flying angle of the Farman machine is seven degrees. Lateral movement is obtained by the vertical plane at the rear of the apparatus, the principle being that of a boat's rudder.

### Aeroplane Piloting Is Complicated.

Though the steering wheel is in external features identical with that of an automobile, its operation is not the simple one known to every driver of a car. The "driver" of an aeroplane has to steer in three directions: length, width and height. The steering wheel slides toward or away from the driver, thus raising or lowering the equilibreur by the simple transmission shown in drawing. By turning the steering wheel to right or left lateral movement is transmitted to the rudder through the flexible cable *b* winding round the drum *O*.

The motive power of the aeroplane consists of a 50-horsepower eight-cylinder water-cooled Antoinette motor running at 1,050 revolutions a minute, and capable of driving the aeroplane at a speed of 40 miles an hour. The two-bladed propeller has a diameter of 90 inches and is constructed of aluminum. A rising movement is obtained as soon as the speed reaches 36 to 40 feet a second.

Steel tube is used exclusively for the chassis, designated in the sketch by *T*. It is this chassis, equipped with bicycle wheels which has to carry all the weight of the aeroplane when a start is made by a preliminary canter over

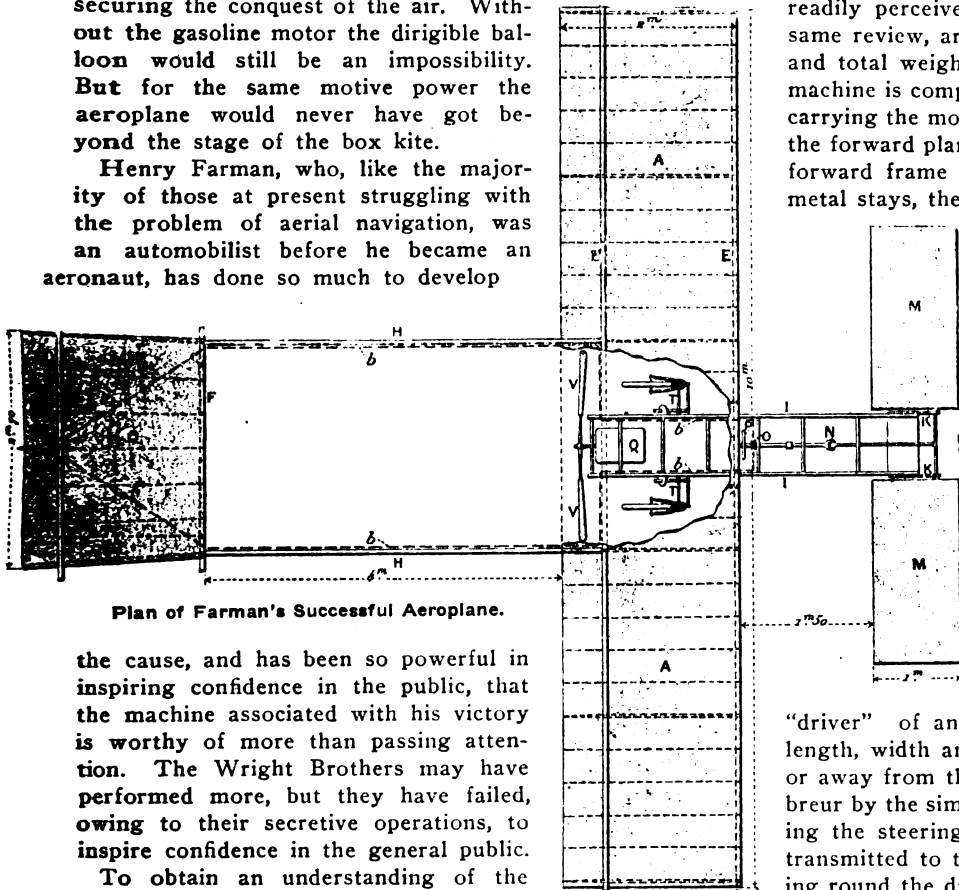

Plan of Farman's Successful Aeroplane.

the cause, and has been so powerful in inspiring confidence in the public, that the machine associated with his victory is worthy of more than passing attention. The Wright Brothers may have performed more, but they have failed, owing to their secretive operations, to inspire confidence in the general public.

To obtain an understanding of the Farman machine, it should be borne in mind that it, like all other aeroplanes, is of the heavier than air class, that it has no sustaining gas bag, and that it can only remain afloat so long as it is in motion. Three fundamental principles underlie all machines of this nature: The effort of the wind or the motor necessary to raise the aeroplane decreases with the increase of the bearing surface and the decrease of weight; power of rising in the air increases with the force of the wind or the speed with which the apparatus is driven through the air; in proportion as the angle of attack is decreased (the angle formed by the horizontal and the line of travel of the aeroplane) the power necessary to keep the apparatus afloat is diminished. An aeroplane

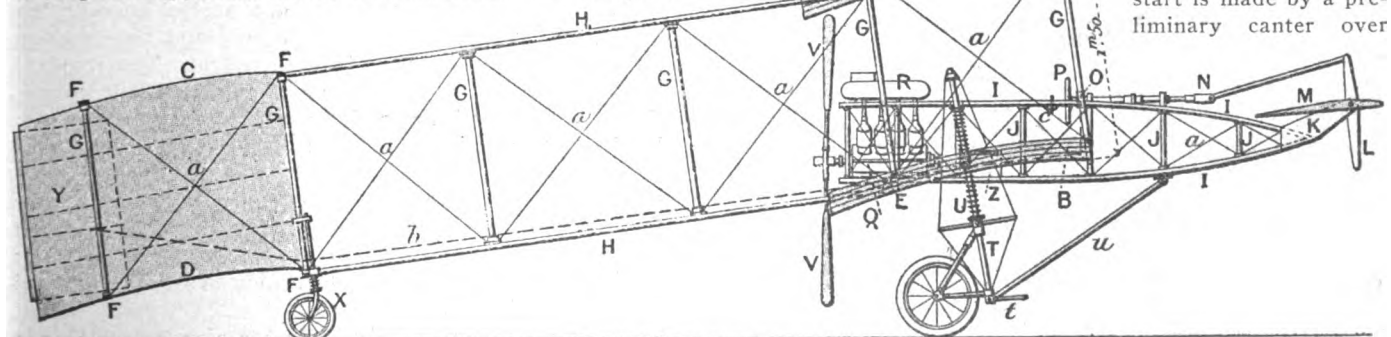

Elevation of Farman's Aeroplane.—A, upper forward plane; B, lower forward plane; C, upper rear plane; D, lower rear plane; H, steel frame uniting forward and rear cells; I and J, forward frame carrying motor and pilot's seat; M, equilibreur; O, steering wheel operating rudder and equilibreur; Q, 50-horsepower, eight-cylinder Antoinette motor; R, water tank; S, gasoline tank; T, chassis on which steering wheels are mounted; U, springs; V, aluminum propeller; X, rear wheels; Y, rudder; Z, pilot's seat on storage battery case; b, cable operating rudder; c, ignition control.



the ground. The wheels are pivoted to run on the ground at any angle and are necessarily subjected to severe strains when the 1,000-pound apparatus descends to earth; yet so satisfactory is the construction that after more than 300 descents the chassis and wheels are in perfect condition. The pair of wheels at the rear, also mounted on coil springs, are merely intended to prevent the tail dragging on the ground during preliminary runs.

The forward cellular bearing surface, which may be compared to the wings of a bird, is formed by two long, curved surfaces of varnished canvas, parallel and about 60 inches apart. A dozen bamboo uprights unite the two surfaces, and laths at short intervals support the canvas covering. The two bearing surfaces are curved in length and width, this form offering a certain resistance to the escape of the air and thus increasing the sustaining power of the aeroplane.

Four tubes, reinforced by uprights and wire stays, unite the forward cell to the rear cell or tail, the function of which is to act as a counter weight or ballast of the forward part. It may, with considerable accuracy, be compared to the tail of a kite. This rear cell is much smaller than the forward one, the width being only 8 feet instead of 32. Its four lateral surfaces are covered with varnished canvas, the front and rear being left open to allow the free passage of air.

It is this huge box kite, equipped with a gasoline engine and manned by an automobilist, that has proved to the world the possibility of aerial navigation. Farman, who has the additional distinction of having achieved success on his very first flying machine, believes with all aeronauts that the ultimate complete conquest of the art of flying is but a matter of time. Unlike many untamed enthusiasts, however, Farman realizes present limitations; his machine has flown, and flown over such distances as to prove its worth, but the flights were only the feeble efforts of a fledgling.

#### RENAULT AIR-COOLED ENGINE FOR FARMAN.

Henry Farman, the champion of the aeronautical world, announces that his new aeroplane will be fitted with an air-cooled engine, instead of the eight-cylinder water-cooled motor used for some time past. He has found a change necessary owing to the difficulty of carrying a sufficient amount of water for a lengthy flight, and the handicap of piping, radiator and pump, which, however lightly they may be constructed, all add to the weight of the flying machine.

The next aeroplane will be fitted with a specially designed eight cylinder, air-cooled Renault engine of 3.5 by 4.7 bore and stroke. Horsepower is stated to be 45 at 1,500 revolutions per minute. Total weight is 286 pounds, which would appear at first sight not to be as advantageous as has been obtained by other makers, but this is the exact weight in running condition, and includes magneto and everything connected with the cooling system.

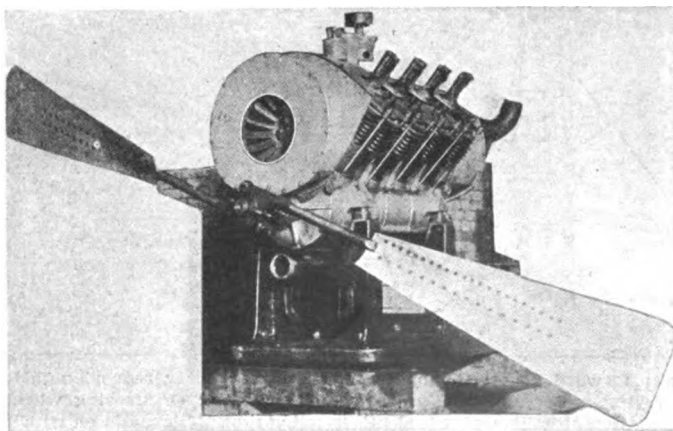

Eight-Cylinder Renault Aero Engine for Farman.

The eight cylinders, provided with radiating flanges over the entire length of the combustion chamber, are arranged in V, the two groups of four being disposed in such a manner that two connecting rods are attached to one throw of the crankshaft. This arrangement reduces the length of the crankshaft, diminishes weight, and, though there is no fly-wheel, the engine is perfectly balanced. Except that they are somewhat lighter than usual, the pistons are similar to those used on the standard water-cooled engines, and are fitted with the same circular groove in their base, pierced with holes to prevent oil passing from crankcase into combustion chamber.

All valves are operated by a single camshaft, machined out of the solid. The exhaust valves, placed above the inlet valves in order to obtain a higher compression, are operated by overhead rocker arms. Spark plugs are placed between

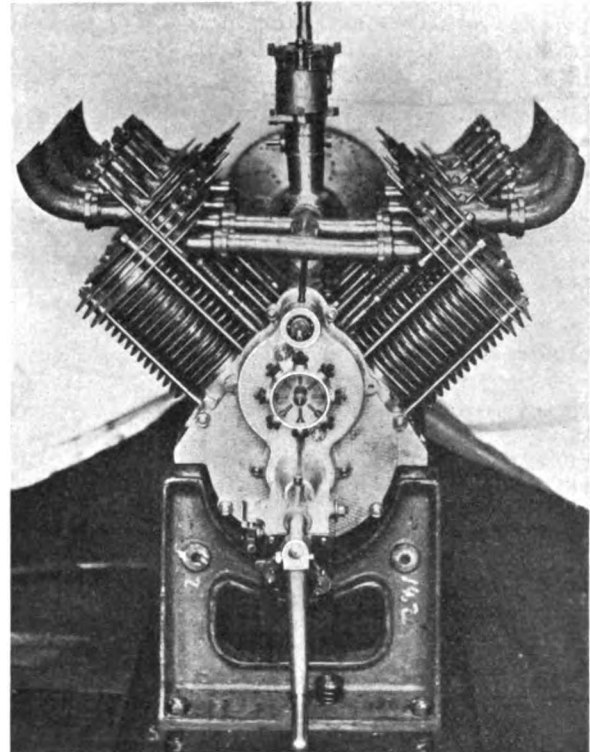

Valve and Intake Arrangement of Renault Air-Cooled Engine.

the two valves. In the matter of lubrication the air-cooled engine is in every respect similar to the water-cooled variety constructed by Renault.

Some successful constructors of aeronautical engines have abolished the carbureter in favor of a system by which the gasoline is injected direct into the cylinders. According to the Renault engineers, the slight gain in weight is offset by the irregularity of working and the largely increased consumption. More gasoline being consumed, a greater quantity has to be carried, necessitating a larger tank and thus making the two systems equal on the basis of weight. The standard Renault carbureter has therefore been retained, but considerably lightened by being entirely constructed of aluminum.

In the matter of ignition, too, a little weight might have been saved by adopting dry cells or storage batteries, but it was preferred to use a high-tension Bosch magneto, similar in principle, but smaller and lighter than those used on the cars. As can be seen from the illustration the magneto is carried in an accessible reversed position below the forward end of the crankshaft.

The cooling system comprises a couple of fans revolving in a light metal casing covering the entire engine. The cooling air drawn into the housing by the forward opening completely encircles the engine and is driven out at the rear. The two cuts of the engine show it with and without metal casing.

**SOME AMERICAN TAXICABS.**

The production of taxicabs, a field of activity with enormous possibilities, is now receiving very close attention by some of the more important and best equipped American factories. Vague announcements regarding intentions of building this special type of automobile have not been lacking for the past six months, but it is during more recent days that the actual cars have made their appearance.

The H. H. Franklin Manufacturing Company has entered the taxicab field, naturally with an air-cooled car. The town vehicle is built on the Franklin 16-horsepower chassis, which has a four-cylinder engine with jump spark ignition, current being supplied from a storage battery. Wheelbase is only 92 inches, which makes the car an especially easy one to handle in crowded city traffic. Transmission is of the progressive type, and final drive through rear live axle, as in all Franklin models. A landaulet body, elegantly upholstered in soft black morocco, the most sanitary material for public service, is provided for taxicab service, the model being known as G landaulet. A number of these cars are now being tested in public service. One of their most valuable features is their low weight and consequent low tire and gasoline upkeep. The machine is declared to weigh but 1,850 pounds.

Chicago will receive the first of the Elmore taxicabs now under construction. The standard 24-horsepower chassis, with its wheelbase shortened to 102 inches, has been adopted. The power plant is a three-cylinder two-cycle valveless engine capable of driving the cab on a gearing of 3 1-2 to 1, at speeds varying from 4 to 30 miles an hour. Total weight of the taxicab is declared to be less than 2,300 pounds. Provision has been made in the landaulet for three inside passengers. The inside height of the body is 60 inches, and width 40 inches. Between the front and rear seats the width is 27 inches. Upholstering is furnished either plain or in biscuit pattern, in cloth or leather. Arm straps are provided, the doors are opened by inside latches, and both the front and door windows are of the drop pattern. The regular color of the Elmore taxicab is dark green with a light, red stripe.

In the new Northern coupé, the Northern Motor Car Company, of Detroit, Mich., has produced an elegant town vehicle to compete with the electric for silence and flexibility while having all the endurance powers of the high-grade gasoline automobile. The power plant is a 24-horsepower motor under a bonnet forward, and is remarkable for its silent operation. The change speed lever has been placed under the steering wheel in order to group all the operating mechanism and give easier control for city work. The body is a handsome example of the coachbuilder's art. It has large, roomy doors, wide seats, is comfortably upholstered, has adjustable beveled plate glass windows front and rear, and is lighted by an electric dome light. The standard finish is black, handsomely striped.

One of the first firms, either here or abroad, to enter the field with an air-cooled taxicab is the Oscar Lear Automobile Company, builders of the Frayer-Miller car. The taxicab is fitted with the Frayer-Miller 24-horsepower air-cooled engine, its cylinders measuring 4 1-16 by 5 1-8 inches bore and stroke. Flexibility being a primary requirement of a taxicab, the Frayer-Miller has been geared so that practically all its work may be done on the high gear. The Standard Roller Bearing Axle Company's axle of the heaviest type, with sliding gear transmission as an integral part of the axle, has been employed. This provides three speeds forward and reverse. Wheelbase is 100 inches, tires employed are 32 by 4 inches. The Frayer-Miller patented fenders are employed, as will be seen from illustration, in order that the body of the vehicle may be thoroughly protected from mud. Accommodation is provided for four passengers, two on the rear seats and two on the forward drop seats.

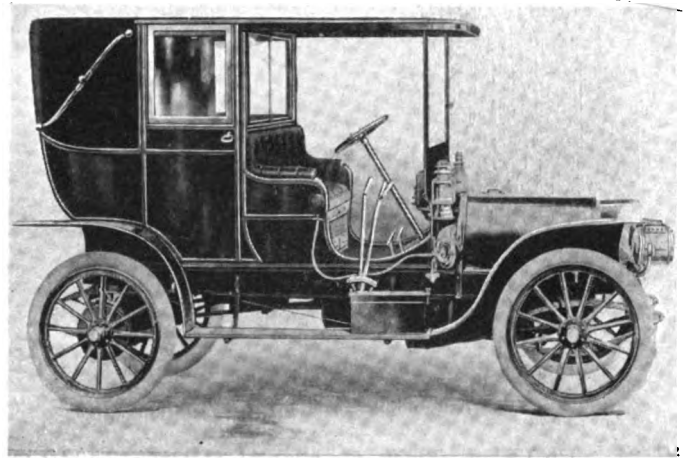

Franklin Taxicab, Champion of Air-Cooled School.



Two-Cycle Engine Feature of Elmore Taxicab.

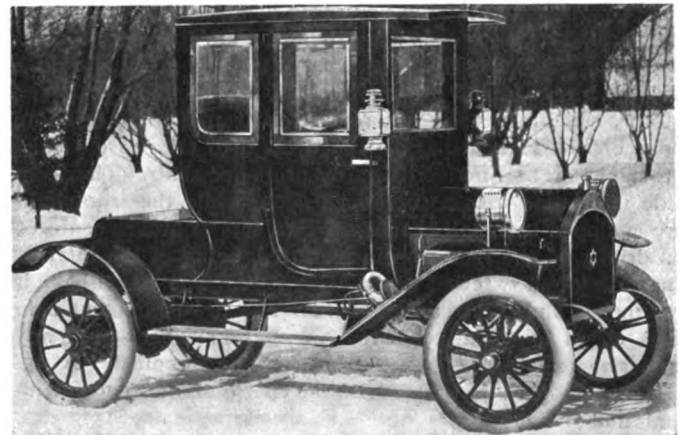

Comfortable Enclosed Auto From Northern Factory.

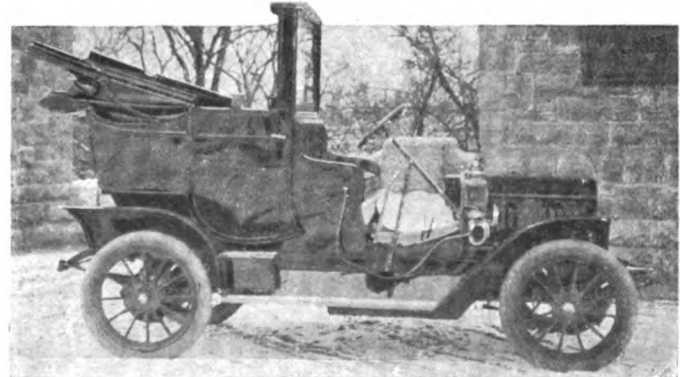

Frayer-Miller Promised For New York Taxicab Service.



A Texas Automobile Product, the "Dixie."

**TEXAS ENTERS THE MANUFACTURING FIELD**

From out the southwest come two new claimants for honors in the moderate priced class, and to judge from their specifications, there is little doubt but that they will succeed in carrying them off. To be more definite, they are the "Dixie" and the "Dixie Flyer," and they hail from Houston, Tex., where the Southern Automobile Company is a pioneer firm in this line. Both cars are built on the same chassis so that a description of the Dixie, which is a touring car, as will be evident from the accompanying photograph, will suffice in large measure for both. Its power-plant consists of a 28-30 horsepower, four-cylinder, four-cycle motor of standard design and construction, carried directly upon the main frame, no sub-frame being employed. It is also equipped with standard accessories of high-grade, a Schebler carbureter with piston throttle, being fitted, while an approved type of force-feed lubricator takes care of this essential. Ignition is of the high-tension type, a six-volt, 60-ampere hour battery being supplied as part of the regular equipment.

The clutch is of the multiple-disc type, contained in the flywheel, while the gear set is of the sliding type acting on the progressive method, a departure being noted here in that only two forward speeds are provided. On the high, the car is geared 3.2 to 1, and on the low 6.6 to 1, or about the same as the intermediate ordinarily used, the flexibility of the motor, which gives the car a speed of from 4 to 50 miles an hour on the high, being depended upon to take care of any other changes. Final drive is by propeller shaft. The front axle is tubular with a three-inch drop, while the front hubs are equipped with ball-bearings. Two sets of brakes centered on drums on the rear wheels are fitted, being of the internal expanding and external contracting type. The wheel-base is 102 inches and the tread standard. The tire equipment consists of 32 by 3 1/2-inch tires on all four wheels and any standard make of clincher tires will be supplied. A 15-gallon fuel tank is fitted. Both types list at \$1,500, with tools and oil lamps. Gas lamps and speedometer are \$150 extra.

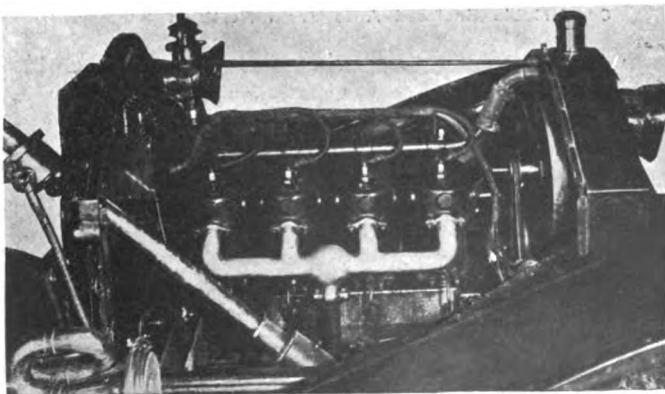

Intake Side of the Motor of the "Dixie."

**GOGGLES FOR DRIVING IN SNOW AND RAIN.**

As all automobilists are aware, nearly every type of goggle yet invented has unfortunately to be abandoned when it is desired to drive fast through rain or snow. If the goggles are retained it soon becomes impossible to see through them, and if they are abandoned the driver suffers much inconvenience, the effect of rain or snow on the eyes at any speed above 25 miles an hour being painful.

To overcome this inconvenience a French inventor has produced a special type of goggle known as the L. I. M., an illustration of which is shown herewith, but which can be more completely understood by a reference to the line drawing, reproduced from *L'Automobile*.

The goggles consist of two opaque tubes *a* joined at the forward end so as to be convergent. The two tubes are mounted on the usual soft leather guard designed to fit close to the face, so that no currents of air can penetrate to the eyes. The upper half of the face of each tube is closed by

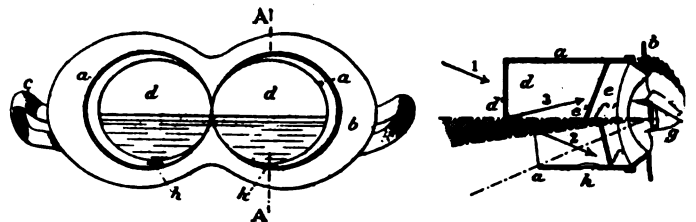

Sectional View of L. I. M. Rain-proof Goggle.

an opaque plate *d*, leaving the lower half open. To increase the range of vision the lower surface of each tube is cut away. Within each tube and behind the forward shield is a second inclined opaque shield *e* and a glass shield *f*, there being sufficient open space between *e* and *f* to give the neces-



Goggles Designed to Protect Against Bad Weather.

sary range of vision under all ordinary circumstances. This range of vision is increased in wet weather by another range through the glass *f*, giving a view of the dashboard, bonnet and wheels of the car.

Protection against rain is obtained in the following manner: rain falling on the shield *d* in the direction of the arrow, or in a more or less oblique direction, drips down to the lower edge of *d*; under the combined influence of the wind and their own weight, the drops of rain are detached from *d* and carried inward until they strike the lower inclined glass shield *f*; then run down the surface of this to the lower part of the tube and finally escape through a hole *h* made for this purpose. In the rare case where a drop of rain managed to pass through the opening between the two guards, its rate of travel would be so slow that it would not reach the eye. Three different types of goggles are made with ranges of vision for speeds of 90, 40 and 25 miles an hour.



New Stretch of Shell Road Built for Savannah Races.

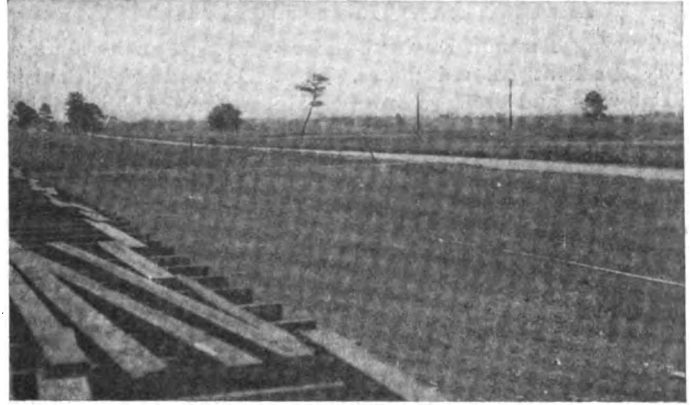

Homestretch from Grandstand—Trees to Be Removed.

### ALL READY FOR SAVANNAH.

SAVANNAH, March 2.—In making every effort to secure the complete success of the two-day races on March 18 and 19, the Savannah Automobile Club has in view the obtaining of the Vanderbilt Cup race for its short but excellent course. The receipt of the news that the Racing Board of the American Automobile Association has instructed Chairman Jefferson DeMont Thompson to investigate the claims of St. Louis and Savannah has increased interest in the approaching event and decided the club to leave no stone unturned to secure the great international speed contest. Data are being collected to submit to Mr. Thompson in favor of the Georgia course, the first batch of information being obtained from the official in charge of the weather bureau, who shows from the records of the past thirty-six years that Savannah October weather is the best in the country. Other information being collected relates to accommodation, transportation facilities, etc.

Preparations for the March races are well advanced. The grandstands are almost completed, most of the curves have been banked and the course has been resurfaced wherever necessary. Provision has been made for warning signs along the road, thirty telephone stations have been provided for, and it has been decided to engage sixty flagmen, in addition to the military, for use during the two days of the races. The concession for a 64-page program has been awarded to J. Schreyer, of New York.

Entries are still being accepted for the Savannah meet on March 18 and 19, the controlling body having decided, in view of the intention of Ormond participants to stop at Savannah on their way North, to grant an extension to March 10. A number of manufacturers who for various reasons had been unable to put in an entry on the official closing date give assurance of cars being engaged.

For the 360-mile race open to stock chassis not exceeding 575 cubic inches piston displacement seven cars are now engaged. Michener will drive the Lozier, which ran in the Brighton Beach twenty-four hour race last summer; Harding and Poole will each have an Isotta-Fraschini; George Robertson and Herbert Lytle, of Vanderbilt Cup fame, will each pilot an Apperson Jackrabbit.

An Acme "sextuplet" runabout will be driven by Malcolm Newstetter, and an American runabout has been entered without nomination of driver.

For the 180-mile runabout race to be run on March 18, there are five entries, comprising two Thomas Detroit, to be driven by L. B. Lorrime and Oliver Light; an Apperson runabout, to be handled probably by George Robertson, and a Pennsylvania, to be driven by L. Zengel.

For the third event, now known as the Southern High Power Car Race, three cars are entered: Harry Levy's 120-horsepower Hotchkiss, a six-cylinder Stearns to be driven by F. W. Leyland, and a six-cylinder Thomas Flyer with G. S. Salzman at the wheel.

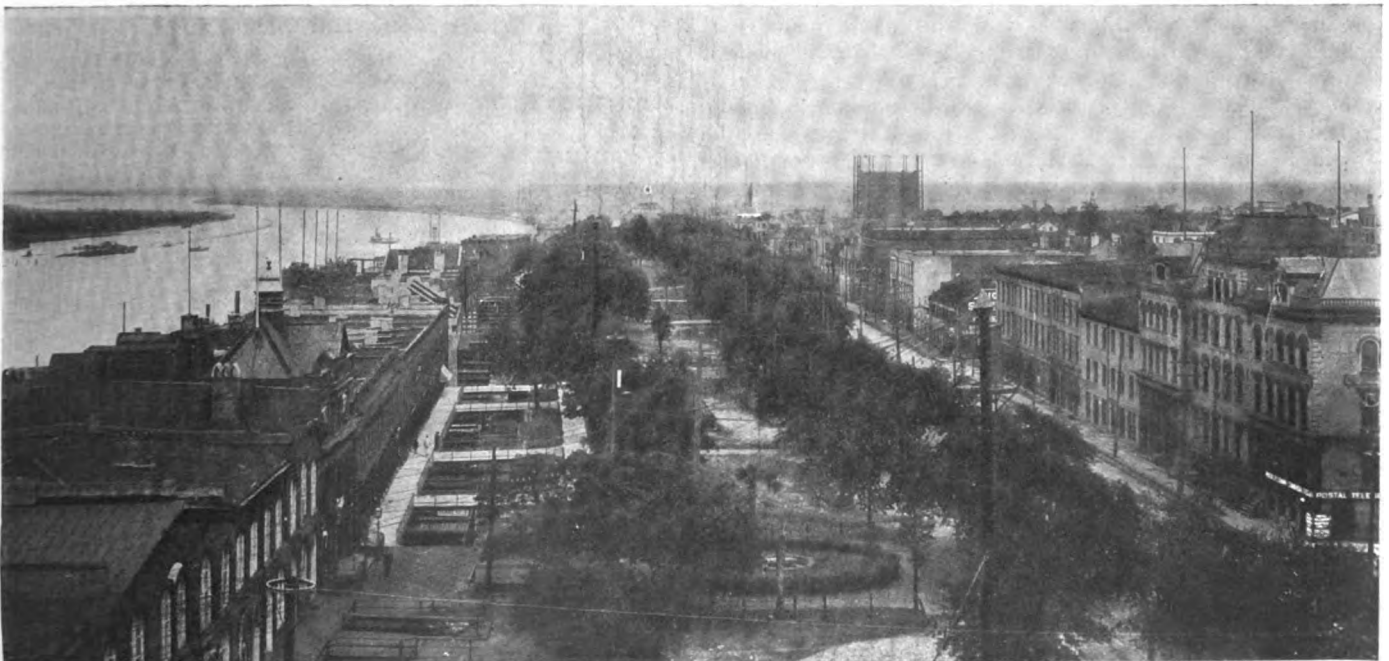

Looking East from the City Hall, Savannah, Ga., Showing River and Cotton Export Business Quarter.



## BOOKS FOR AUTOMOBILISTS.

**Touring Through England.**—Merely because of its numerous excellent colored plates, Thos. D. Murphy's "British Highways and Byways from a Motor Car," published by L. C. Page & Company, Boston, is worthy a place on the book shelves of every automobilist. The author cannot be accepted as the only necessary guide for a tour through England—and indeed frankly states that he has no such pretension—for his journeys appear to have been a series of wanderings selected on the spur of the moment, often running over the same road twice and frequently leading through uninteresting industrial country where fairer routes were available. Nevertheless, the story of how Thomas D. Murphy piloted his Winton Model C through the highways and byways of Old England is sufficiently attractive to interest stay-at-homes, and his descriptions of scenes and customs in various parts of England cannot but be pronounced accurate by the traveler; even the apparent aimlessness of the travels is valuable because of the new scenes which are introduced.

**Scotch Castles and Keeps.**—There is such a wealth of romance and adventure in the land of the Scot that any literary effort on the castles of the north country has full possibilities of attractiveness. Frank Roy Fraprie, in his "Castles and Keeps of Scotland," has certainly lived up to his opportunity, the principal architectural monuments throughout the Lowlands and the Highlands being described in a way that makes the volume valuable as a companion and guide for a tour through this land. The mere mention that the book is published by Page & Company, of Boston, uniform with their well-known volumes on touring in France, is sufficient guarantee of the excellence of its illustrations and artisticness of its get-up. The addition of an outline map would doubtless have been appreciated by readers not fully acquainted with the geographical positions of the places described.

**"The Gas Engine" Revised.**—There are few better authorities on the internal combustion engine than Professor Frederick Remsen Hutton, of Columbia University, and engineers will be interested to learn that John Wiley & Sons, New York, have just brought out an enlarged and thoroughly revised edition of his well-known work, "The Gas Engine." Professor Hutton has made a most exhaustive study of the internal combustion motor of every type, extending over a long period of years, so that his work is the result of practical experience that has been contemporaneous with the development of the gas engine in commercial use. Every possible phase of the subject is dealt with and expounded at length and one of the features of the book that will make it invaluable to automobile engineers as a reference work, is the great mass of authentic data that it contains. It is a volume of close to 600 pages and within its covers will be found the entire history and development of the internal combustion from its very inception, written in a practical and concise manner. It lists at \$5.

## AERO CLUB OF AMERICA SEEKS AERODROME.

In a short time it is expected that the members of the Aero Club of America will have an aeronautical ground on which they may make experimental flights in the neighborhood of New York City with a reasonable amount of privacy and seclusion. Arrangements are now in the hands of the Board of Directors for securing such a ground where members may test their models with security to themselves and no danger to the property of others. A reasonable guarantee will be required from those who are testing their machines in order to safeguard public property.

A few places yet remain at the annual banquet of the club at the Hotel St. Regis, March 14. Members are at liberty to invite guests and the tables will be arranged each to accommodate parties of eight persons.

## THE AUTOMOBILE CALENDAR.

## AMERICAN.

## Shows and Meetings.

- Mar. 7-14.....—Boston, Mechanics' Building and Horticultural Hall, Boston Automobile Dealers' Association. Chester I. Campbell, manager, 5 Park Square.
- Mar. 11.....—Boston, Bay State Auto Association Clubhouse, First Quarterly Meeting, Society of Automobile Engineers.
- Mar. 9-14.....—Buffalo, Convention Hall, Sixth Annual Automobile Show, Automobile Club of Buffalo. Dai H. Lewis, manager.
- Mar. 23-28.....—Indianapolis, Ind., Annual Show, Automobile Dealers' Association.
- Mar. 18-21.....—Rochester, N. Y., New Convention Hall, First Annual Show, Automobile Dealers' Association and Rochester Automobile Club. Bert Van Tuyle, manager.
- Mar. 18-24.....—New Haven, Conn., Music Hall, Annual Show, New Haven Automobile Dealers' Association.
- Mar. 21-28.....—Toronto, Canada, St. Lawrence Arena, Automobile Show. R. M. Jaffray, manager.
- Apr. 5-12.....—Montreal, Canada, Arena, Third Annual Automobile and Sportsman's Show. R. M. Jaffray, Mgr.
- April 6-8.....—Denver, Mammoth Rink, Annual Automobile Show. G. A. Wahlgreen, manager.

## Race Meets, Hill Climbs, Etc.

- Mar. 18-19.....—Savannah, Ga., Savannah Automobile Club.
- April 24.....—Briarcliff Trophy Race, Westchester County, N. Y. Robert L. Morrell, chairman.
- May 4-5.....—Harrisburg-Philadelphia and Return, 150-mile Endurance Run, Motor Club of Harrisburg.
- May 15.....—Chicago, Algonquin Hill Climb, Chicago Motor Club.
- May 16.....—Hartford, Conn., 200-mile Endurance Run, Automobile Club of Hartford.
- May 30.....—Bridgeport, Conn., Sport Hill Climb, Bridgeport Automobile Club.
- June 24-27.....—Chicago, 1,200-mile Reliability Run, Chicago Motor Club.
- July 6-8.....—Buffalo, National Convention of the A. A. A., and Start of Fifth Annual Tour.
- Sept. 14.....—Chicago, Annual Economy Run, Chicago Motor Club.

## FOREIGN.

## Shows.

- Mar. 21-28.....—London, Agricultural Hall, Cordingley's Show.
- Mar. 26-April 4.....—London, Olympia Industrial Vehicle and Motor Boat Show.
- May 17-June 2.....—Moscow, Russia, International Automobile Exposition, Automobile Club of Moscow.

## Race Meets, Hill Climbs, Etc.

- April 1-13.....—Monaco Motor Boat Races and Motor Boat Exhibition, International Sporting Club of Monaco.
- April 25-May 25.....—Industrial Vehicle Competition, Automobile Club of France.
- May.....—Paris, Competition for Agricultural Automobiles, auspices of "L'Auto." (Date to be announced.)
- May 1-31.....—Automobile Taxicab Competition, France, Automobile Club of France.
- May 10.....—Sicily, Targa Florio, Automobile Club of Italy.
- June 1-18.....—Reliability Trials for Pleasure Cars, Automobile Club of Great Britain.
- June 9-17.....—Touring Competition for the Prince Henry of Prussia Prize, Germany, Imperial Automobile Club of Germany.
- July 6.....—Voiturette Grand Prix, Dieppe Circuit (Automobile Club of France).
- July 7.....—Grand Prix of Automobile Club of France, Dieppe Circuit.
- July 13-17.....—Ostend, Belgium, International Race Week, Automobile Club of Ostend.
- July 20-30.....—Ardennes Circuit Races and Coupe de Liederke, Automobile Club of Belgium.
- Aug.....—France, Coupe de la Presse, Automobile Club of France. (Exact date to be announced.)
- Aug. 29-30.....—France, Mont Ventoux Hill Climb, Vauclusien Automobile Club.
- Sept. 1-8.....—French Voiturette Contest, auspices of "L'Auto."
- Oct. 11.....—Berlin, Germany, Gordon Bennett Balloon Race. Aeronautical Club of Berlin.

## LONG ISLAND TEST PROVES AUTOMOBILE ECONOMY

**A**IR-COOLERS won the honors in the mid-winter economy test of the Long Island Automobile Club, February 25. Harry H. Knepper's 24-horse-power Frayer-Miller was found by the gasoline and fuel committee to have transported its passengers from the Brooklyn clubhouse to Montauk Point and return at the lowest cost per head, and was awarded the first prize. The Franklin, handled by H. A. Vail, used less gasoline than any car on the run, but as it carried only four passengers the cost per head worked out higher than for the Frayer-Miller, and the air-cooler from Syracuse had to take second position. R. Morton brought the four-cylinder Pullman home in third position and had the honor of driving the most economical of the water-cooled cars. The two-cylinder Maxwell, though not a prize winner, ran the leaders very close, and was just as hard pressed by the four-cylinder Pope-Hartford, which lost on oil what it gained in gasoline.

The most noteworthy feature of the 234-mile mid-winter run was the extreme economy displayed by the greater part of the nineteen cars qualifying within the time limit. The winning Frayer-Miller, with five persons on board, had a total cost for fuel and lubricating oil of but \$3.56, or 71 1-5 cents per head. The Franklin's cost was the lowest of the competition, totaling only \$3.10; as this sum had to be divided by four, the cost worked out at 77 1-2 cents per head. Ten out of the nineteen cars accomplished the run at a per capita cost of less than one dollar, and eight others kept the cost below two dollars. Calculations were based on gasoline at 25 cents per gallon and lubricating oil at \$1 per gallon.

Among the seven-passenger cars the best performance was made by H. A. Martin's American Mors, with a cost of only 92 cents per passenger; the economy is the more remarkable in view of the fact that the Mors was a closed limousine with wind shield and all accessories for winter touring. Of the six-cylinder contestants, C. A. Carlson's Winton was the most economical,



Frayer-Miller, Franklin and Pullman, Winning Trio.

### HOW THE CARS FARED ON FUEL BASIS.

Two hundred and thirty-four miles had to be covered by the contestants within a time limit of eighteen hours. There was no penalization of any kind. Oil and gasoline were supplied in sealed, measured cans, and controlled throughout by official observers. Cost of fuel per head formed the basis of awards. Twenty-three cars started and nineteen qualified by covering the distance in the time limit imposed.

Car	Gasoline gals.	Oil quarts	Total cost	Passengers	Per capita cost
Frayer-Miller	13.000	1 1-4	\$3.56	5	\$0.71 1-5
Franklin	9.875	2 1-2	3.10	4	77 1-2
Pullman	13.125	2 1-2	3.91	5	78 1-5
*Maxwell	14.937	1	3.98	5	79 3-5
Pope-Hartford	14.000	2 1-8	4.03	5	80 3-5
¶American Mors	21.125	4 3-8	6.44	7	92
Pope-Hartford	14.875	4 1-2	4.85	5	97
†Winton	26.375	7-8	6.82	7	97 3-7
Acme	25.50	2	6.88	7	98 2-7
Thomas Detroit	15.218	4 1-2	4.93	5	98 3-5
Rambler	15.937	3 1-8	5.01	5	1.00 1-5
†Acme	24.875	3 1-2	7.10	7	1.01 3-7
Lozier	27.75	8 1-2	8.07	7	1.15 2-7
Maxwell	22.50	1 1-2	6.00	5	1.20
Cadillac	18.25	9 3-4	6.00	4	1.50
Mora	16.000	8 1-8	5.03	3	1.67 2-3
Studebaker	27.75	6 1-8	8.53	5	1.70 3-5
†Stevens-Duryea	29.50	5 5-8	8.78	5	1.75 3-5
†Acme	30.375	3 3-4	8.53	4	2.13 1-4

\*Two-cylinder car. †Six-cylinder car. ¶Limousine.

with a per capita cost of 97 3-7 cents per head. The oil consumption was remarkably low, being but seven-eighths of a quart for 234 miles. J. D. Rourk's Cadillac, the only single-cylinder machine in the run, was debarred from a better position owing to the collapse of a wheel and trouble on the road which caused a greater consumption of fuel than usual. Thirteen of the nineteen successful cars, including the Franklin, were equipped with Diamond tires, all of which completed the run without a single case of puncture or blow-out.

In credit to some of the powerful, speedy cars, it should be pointed out that there were no class divisions whatever, single-cylinder and large six-cylinder touring cars competing on a common basis. This naturally placed the speedy runabout and tour-about class at a disadvantage, a fact which should be borne in mind in examining the table of performances. The deficiencies of the test were realized by the club committee, who sought more to prove the economy of the automobile as a pleasurable means of transportation than to test the all round efficiency of the machines engaged.

Though not a complete comparison, it is still interesting to note the difference in cost between automobile and railroad travel, as exemplified in this run. The journey to Montauk Point and return by rail costs \$5.28 each; thus the five passengers on the winning car would have handed over \$26.40 for their trip, instead of \$3.56. Between 70 and 80 cents, the individual cost on the first half dozen cars, and the railroad charge of \$5.28 there is a difference which, though not surprising to the automobilist, will probably astonish the general public. Even the speedy high-powered runabout, with a rate of travel equaling that of an express train, keeps its fuel cost less than half that of the railroad fares.

Obviously, the cost charge is not complete, for there is no allowance for tires, maintenance, and depreciation; adding a substantial percentage for this, however, the automobile still stands out as remarkably efficient on the economic basis.

# THE AUTOMOBILE

Vol. XVIII

Thursday, March 5, 1908

No. 10

## THE CLASS JOURNAL COMPANY

Flatiron Building, Madison Square  
New York City

H. M. SWETLAND, President

### EDITORIAL DEPARTMENT

A. G. BATCHELDER, Managing Editor  
R. F. KELSEY, Associate Editor C. B. HAYWARD, Engineering Editor  
W. F. BRADLEY

### BUSINESS DEPARTMENT

A. B. SWETLAND, Business Manager  
LOUIS R. SMITH FRANK B. BARNETT  
W. I. RALPH, 1035 Old South Building, Boston, Mass.  
C. H. GURNETT, H. E. WESTERDALE, 836 Monadnock Block, Chicago, Ill.

Cable Address - - - - - Autoland, New York  
Long Distance Telephone - - - - - 300 Gramercy, New York

### SUBSCRIPTION RATES:

United States and Mexico - - - - - One Year, \$3.00  
Other Countries in Postal Union, including Canada - - - - - One Year, 5.00  
To Subscribers—Do not send money by ordinary mail. Remit by Draft,  
Post-Office or Express Money Order, or Register your letter.

### FOREIGN SUBSCRIPTION AGENTS:

ENGLAND:—Illiffe & Sons, Limited, 29 Tudor Street, London, E. C.  
FRANCE:—Boyveau & Chevillet, 22 Rue de la Banque, Paris.  
GERMANY:—A. Seydel Mohrenstrasse 9, Berlin.

Entered at New York, N. Y., as second-class matter.  
The Automobile is a consolidation of The Automobile (monthly) and the Motor Review (weekly), May, 1902, Dealer and Repairman (monthly), October, 1903, and the Automobile Magazine (monthly), July, 1907.

Copies printed in 1905 - - - - - 730,000  
" " in 1906 - - - - - 791,000  
" " in 1907 - - - - - 888,000

## FEDERAL AID IN ROAD BUILDING PROBABLE.

When such a far-reaching and powerful organization as the National Grange assumes the aggressive in advocating that the Federal Government should aid the States in the building of roads, then it would seem that the day is near at hand when the construction of highways is to begin in earnest throughout the entire country.

"No argument can be advanced in favor of the annual appropriations by Congress on behalf of river and harbor improvements that does not apply even more strongly to the improvement of our public roads," contends the Grange—one million strong—in resolutions unanimously adopted. Continues the resolving: "We favor the immediate enactment of legislation by Congress making liberal Federal appropriations for the improvement of the public highways of the country, these appropriations to be expended in such manner as Congress may prescribe."

Of course, all automobilists will help the Grange in its efforts to secure Federal aid in this vital building of the roads, and here again comes into play the spreading national growth of the American Automobile Association, the Good Roads Board of which, under the chairmanship of the energetic Hooper, is accomplishing much more than would appear to be the case on the surface. Those who sit in our legislative halls at Washington are becoming aware that automobilists are watchful of measures which concern them, and this keenness of sight will continue until the desired things become realities.

Once upon a time when the cyclists—a hundred thousand strong—talked and argued for good roads from

dawn to darkness, some attention was paid to their words, but not enough heed was given to accomplish anything very tangible. The persistent efforts were not wasted entirely, but the man who lives in the country is never as quickly convinced as is the urban dweller, and in this building of the roads the farmer pays his share of the cost only through the results of toil with profits won from the soil by the sweat of his brow. Economy is to him a necessity which teaches the value of every dollar expended, and, though he soon realized the advantages of roads deserving the name, the cost staggered him when the burden seemed to fall heaviest in his direction. But with the coming of substantial State aid he gladly came forward with his share of the money, and while progress in many States has been meager and tedious, the knowledge gained in the work of education is the basis for that unanimous support which is going to "House Bill No. 15,837."

Once National roads are built there must come National supervision in their maintenance, for that has been the experience in those European countries where roads building is rated a science of great worth to the welfare of the nation. We shall quote from a letter that has just come to hand from one of our regular contributors, Francis Miltoun, who is an American with a temporary residence in France, and who has just returned from a tour in Tunis and Algeria. Mr. Miltoun is a student of roads, and this is what he says on the care of National highways after they are built:

"The point I make is that Tunisia, only a quarter of a century old as a civilized country, and Algeria, barely three-quarters of a century old, can make good roads and keep them up efficiently. So can we, but they must be National roads, under National supervision. That's my slogan. Did you know that the famous Bath road in England is under the control of sixteen different authorities—from London to Bath—that is why it is good in parts and bad in parts. The Route d'Antibes, from Paris practically to the Italian frontier, is under one administrative control, and that is why it is a good road all the way along. It is this same central control that one finds in Algeria and Tunisia."



## TECHNICAL TRAINING FOR REPAIRMEN.

To say the least, it is unfortunate that more of the men who hang out their shingles to invite the passing autoist who may be in trouble, to cure the ills of his car at their establishments, should not have had the benefit of a prior technical training before embarking in the lucrative practice of learning how to repair automobiles at their owners' expense, not to mention the damage done to the machine itself. It would be far from just to accuse repairmen, as a body, of ignorance, but the number of cases in which the charge is justified is lamentable, as their efforts tend to discredit their better equipped confreres and their misguided tinkering not only fosters the delusion that the automobile is a mechanical mystery, but adds enormously to the annual cost of maintaining a car. Their influence in this direction proves detrimental to the sport of automobiling and many a good car has been utterly condemned by its owner on the prejudiced opinion of an incompetent repairman. A little training would indeed be a most valuable asset.

## A. A. A. NATIONAL CONVENTION AT BUFFALO, JULY 6-7

**D**ECISION to hold a National Convention at Buffalo immediately preceding the start of the Annual Tour, the appointment of a European touring representative, election to membership of the West Virginia State Automobile Association and the Automobile Club of Vermont, attention to the legal situation, and discussion of a campaign for increased individual membership was the well-filled program of the directors' meeting of the American Automobile Association, at New York, Tuesday, March 3.

Buffalo will be the scene of a National Convention of the A. A. A. July 6 and 7, the subjects to be discussed being good roads, touring and legislation. As the Fifth Annual A. A. A. Tour will start from Buffalo on July 8, the first convention will certainly be the means of uniting large numbers of automobilists from all parts of the country.

Five State associations have been elected to the A. A. A. since the annual meeting in November, making a total of twenty-one associations now affiliated. Organization work having been completed in Virginia and Kentucky, those States will probably apply for membership at the next meeting.

Chairman Hower announced that he had made arrangements with Victor Breyer, of Paris, France, to become European touring consul for the association for the year 1908. Mr. Breyer, who is well known as the manager of the 1907

Grand Prix, will give free information on touring to all A. A. A. members abroad, assist them to hire cars, engage chauffeurs, and furnish all necessary help in touring abroad.

Chairman Terry, on behalf of the Legislative Committee, asked for the co-operation of State associations and clubs in securing a large delegation on the occasion of the hearing of the Federal Registration Bill before the Judiciary Committee of the House of Representatives, at Washington, March 12. Chairman Terry and his associates are confident of the unanimous approval of the bill by the Judiciary Committee and Congress, and its passage within a few weeks. Among the detail matters discussed was one for an increase of individual members in all States, whether a State association existed or not.

The meeting, which was presided over by President Hotchkiss, was attended by Chairmen Thompson, Hower and Hooper, of the Racing, Touring and Good Roads Boards, the following directors: Lewis R. Speare, Boston; Edward Kneeland, Pittsburg; S. L. Haynes, Springfield; Paul C. Wolff, Pittsburg; Isaac Starr, Jr., Philadelphia; George A. Post, Paterson, N. J.; John P. Coghlin, Worcester, Mass.; Giles H. Stilwell, Syracuse, N. Y.; Treasurer Farrington, and Secretary Elliott. The Pittsburg Automobile Club extended an invitation to hold the next meeting in that city.

### TO ATTACK JERSEY LAW IN COURTS.

**NEWARK, N. J., March 3.**—New Jersey automobilists have abandoned all efforts to obtain a moderation of the proposed Frelinghuysen amendments to the present automobile law and will attack the constitutionality of the latter in the courts on the ground that it is double taxation. In an interview with a representative of the *Newark Call*, Joseph H. Wood, former president of the New Jersey Automobile and Motor Club, said: "Motorists have come to realize that the automobile law question can never be settled satisfactorily until it is settled on fundamentally just principles. For the recognition of these principles we will now fight and there will be no quarter given. The era of compromise is over, so far as Jersey automobilists are concerned."

The New Jersey Automobile Trade Association held an animated meeting at the automobile show at Electric Park on Saturday last to discuss the matter, and a resolution attacking the act was unanimously indorsed. This states that all conferences with the State authorities on the subject are at an end, and in it the association goes on record as being "unqualifiedly and unalterably opposed to the high, prohibitive and inequitable license fees proposed."

H. A. Bonnell, secretary of the New Jersey Automobile and Motor Club, sent out notices yesterday calling a special meeting for Friday for the purpose of discussing the present law and the proposed amendments thereto. The meeting has been called at the request of W. C. Crosby, chairman of the legislative committee, so that the law may be discussed at length and thoroughly understood. A smoker will be held in connection with the meeting.

### PRIVATE RACER FOR VANDERBILT CONTEST.

Though all details are at present withheld, Raymond Healy declares that he has just had constructed in this city a powerful racing car intended for the Vanderbilt Cup race and for demonstrating the endurance of an automobile tire in which the owner is interested. The car is declared to develop 90 horsepower and to have shown a speed of 95 miles an hour. Krupp steel has been employed in its construction to a considerable extent, and total weight is said to be under 1,800 pounds. The gasoline tank has a capacity of 25 gallons.

### ILLUMINATED PARADE FOR AUTO CARNIVAL.

New York will be a busy automobile center during the week beginning April 6, the six days on which the New York Automobile Trade Association intends to hold carnival in celebration of the tenth anniversary of the introduction of the automobile to the city, and incidentally to foster Spring buying in the metropolitan district.

Arrangements, which are now well in hand, provide for an interesting illuminated parade on the evening of Tuesday, April 7. There will be four sections, devoted respectively to old cars, modern vehicles, private decorated automobiles and commercial cars. In the retrospective section old cars of 1903 or earlier will show in panoramic form the evolution of the automobile from the earliest days. A part of this section will be taken up by racing cars having figured in the more important speed contests of the past. The modern section will comprise the best models of the day.

On Thursday, April 9, there will be a hill climb in some spot near the city, the exact location of which has not yet been decided upon. On Friday, April 10, there will be a daylight parade and a short run to some club or resort, where luncheon will be served. It is the intention of the New York Automobile Trade Association and those independent dealers who have promised their co-operation in the scheme, to keep "open house" during the entire week. Special features will be installed at all the showrooms and each firm will hold a private exhibition.

### WHAT THE LAWMAKERS ARE DOING AT ALBANY.

**ALBANY, March 3.**—The Fowler bill, which would require automobilists to pay a tax of 50 cents per 100 pounds, in addition to their registration fee, was held over by the taxation committee at a hearing to-day, Assemblyman Fowler admitting that there were features which should be changed. The hearing of the Wainwright bill to compel all vehicles using the highways to carry lights at night was put over until March 10. President O. A. Quayle, Attorney M. T. Bender and others of the state automobile association are in conference with a number of the Senators and Assemblymen over the provisions of the proposed bill to revise the present automobile law.



## A. A. A. ANNOUNCES LEGISLATIVE AND TOURING BOARDS

At the last meeting of the Executive Committee of the American Automobile Association, the members appointed to the Legislative Board for the present year were announced. Charles T. Terry, New York, continues as chairman, and this year he will be supported by a much larger board than previously in order that effective work may be done in connection with the passage of the Federal registration bill now pending in Congress. The board is largely composed of representative lawyers who are interested in securing such legislation as will put an end to the confusion and injustice resulting from the working of the present State laws. The Legislative Board is composed of the following:

**CALIFORNIA.**  
G. Allen Hancock, Los Angeles.

**COLORADO.**  
W. H. Bergtold, Denver.

**CONNECTICUT.**  
Walter S. Schutz, Hartford.  
James E. Cooper, New Britain.

**DELAWARE.**  
John Bancroft, Wilmington.  
Samuel J. Wright, Newark.

**DISTRICT OF COLUMBIA.**  
Robert B. Caverly, Washington.

**FLORIDA.**  
J. B. Parkinson, Daytona.

**GEORGIA.**  
R. J. Davant, Savannah.  
M. Felton Hatcher, Macon.

**ILLINOIS.**  
Sidney S. Gorham, Chicago.  
George W. Ehrhart, Decatur.  
John Farson, Chicago.  
William K. Bracken, Bloomington.  
Samuel P. Irwin, Bloomington.  
R. N. Baker, Springfield.

**INDIANA.**  
Fred. M. Ayers, Indianapolis.  
Samuel Murdock, LaFayette.  
Edgar Apperson, Kokomo.

**IOWA.**  
Dick R. Lane, Davenport.

**KENTUCKY.**  
George H. Wilson, Louisville.

**LOUISIANA.**  
William McL. Fayssoux, New Orleans.

**MAINE.**  
Fred. J. Allen, Sanford.  
Frederick Hale, Portland.  
Charles T. Libbey, Portland.

**MARYLAND.**  
William C. Devecmon, Cumberland.  
Osborne I. Yellott, Baltimore.  
Robert H. Carr, Jr., Baltimore.

**MASSACHUSETTS.**  
Francis A. Hurtubis, Jr., Boston.  
Samuel L. Powers, Boston.  
Robert C. Cooley, Springfield.  
W. H. Chase, Leominster.  
D. F. Gay, Worcester.

**MICHIGAN.**  
D. M. Ferry, Jr., Detroit.  
Fred E. Rowe, Grand Rapids.

**MINNESOTA.**  
F. B. Nelson, Minneapolis.  
Lou S. Gillette, Minneapolis.  
F. B. Lynch, St. Paul.

**MISSOURI.**  
James Hagerman, Jr., St. Louis.  
Walter Brownlee, Brookfield.  
George Robertson, Mexico.  
Elliott H. Jones, Kansas City.  
B. F. Bradenburg, Kansas City.

**MISSOURI.**  
James Hagerman, Jr., St. Louis.  
Walter Brownlee, Brookfield.  
George Robertson, Mexico.  
Elliott H. Jones, Kansas City.  
B. F. Bradenburg, Kansas City.

**NEW HAMPSHIRE.**  
W. D. Veasey, Laconia.

**NEW JERSEY.**  
W. C. Crosby, East Orange.  
R. C. Jenkinson, Newark.  
J. H. Edwards, Jersey City.  
G. A. Post, Paterson.

**NEW YORK.**  
Charles Thaddeus Terry, New York.  
W. W. Niles, New York.  
Dave H. Morris, New York.  
Dr. William P. Richardson, Brooklyn.  
John A. Barhite, Rochester.  
H. A. Meldrum, Buffalo.  
Giles H. Stilwell, Syracuse.

**OHIO.**  
William W. Smith, Jr., Cincinnati.  
Paul Staley, Springfield.  
C. D. Crites, Lima.  
H. L. Vall, Cleveland.

**PENNSYLVANIA.**  
W. C. Sproul, Philadelphia.  
George F. Huff, Greensburg.  
S. Boyer Davis, Philadelphia.  
Frederick A. Godcharles, Millton.  
Paul C. Wolff, Pittsburg.  
J. Sharp Wilson, Beaver.

**RHODE ISLAND.**  
J. Jerome Hahn, Providence.

**SOUTH CAROLINA.**  
Edward C. Robertson, Columbia.

**TEXAS.**  
W. A. Fraser, Dallas.

**VERMONT.**  
W. D. Woolson, Springfield.

**VIRGINIA.**  
C. B. Richardson, Richmond.  
Joseph E. Willard, Richmond.  
Frederick Lewis, Norfolk.

**WEST VIRGINIA.**  
X. Poole, Martinsburg.

**WISCONSIN.**  
Neal Brown, Wausau.  
James T. Drought, Milwaukee.

**MISCELLANEOUS.**  
J. H. Everest, Oklahoma City, Okla.  
D. C. Bradford, Omaha, Neb.

### Make-up of the A. A. A. Touring Board for 1908.

The appointments to the Touring Board were also gazetted at the same time. Members appointed to the Touring Board are, with few exceptions, secretaries of their clubs. This has been done in the expectation that their chief function during the present year will be to keep the headquarters of the Touring Board informed as to the condition of roads, the existence of speed traps and concerning local customs in the matter of the enforcement of the law in their various neighborhoods. Such members of the committee as are in the route of the Glidden tour will also be expected to coop-

erate with the chairman and secretary both before and during the tour. There will be no executive committee of the Touring Board this year. The personnel of the board is as follows:

Frank B. Hower, chairman, Buffalo, N. Y.  
Dai H. Lewis, secretary, Buffalo, N. Y.

### CALIFORNIA.

Charles B. Hopper, Los Angeles.  
E. C. Hickman, San Diego.

### COLORADO.

Frank L. Ewing, Greeley  
CONNECTICUT.

F. T. Staples, Bridgeport.  
G. K. Dustin, Hartford.  
W. L. Hatch, New Britain.  
G. H. Townsend, New Haven.

### DISTRICT OF COLUMBIA.

LeRoy Mark, Washington.

### FLORIDA.

Herbert P. Race, Jacksonville.  
T. E. Fitzgerald, Daytona.

### GEORGIA.

Arthur W. Solomon, Savannah.  
H. J. Lamar, Jr., Macon.

### ILLINOIS.

Joseph F. Gunther, Chicago.  
George G. Greenburg, Chicago.  
R. A. Whitney, Peoria.  
R. N. Baker, Springfield.

### INDIANA.

Fred M. Taft, Logansport.  
H. A. Brown, Indianapolis.  
Horace E. Kizer, South Bend.

### IOWA.

A. H. Ruebsam, Davenport.

### KENTUCKY.

Charles Chreste, Louisville.

### MARYLAND.

D. A. Clark, Baltimore.  
Charles M. Danzer, Hagerstown.

### MASSACHUSETTS.

F. P. Strout, Springfield.  
J. C. Kerrison, Boston.  
Edward S. Bryant, Brockton.  
F. L. D. Rust, Boston.  
F. E. Frost, Worcester.

### MICHIGAN.

Paul H. Deming, Detroit.  
J. R. Jackson, Grand Rapids.  
Edwin S. George, Detroit.  
C. A. Flood, Hart.  
Charles Haines, Cadillac.  
J. C. Hatfield, Kalamazoo.

### MINNESOTA.

W. W. Walker, Duluth.  
George H. Daggett, Minneapolis.  
H. S. Johnson, St. Paul.

### MISSOURI.

W. P. Stevens, Kansas City.  
S. D. Capen, St. Louis.  
M. T. Slane, St. Louis.

### NEW JERSEY.

James B. Dill, East Orange.  
R. N. Johnston, Atlantic City.  
J. Hiscock, Cape May.  
W. F. Sadler, Trenton.  
George W. Pittenger, Asbury Park.

H. L. Hamersly, Wildwood.

### NEW YORK.

Oliver A. Quayle, Albany.  
G. W. Bowen, Auburn.  
D. H. Lewis, Buffalo.  
C. H. Benedict, Schenectady.  
Forman Wilkinson, Syracuse.  
Robert M. Hunt, Utica.  
S. M. Frechie, Binghamton.  
F. R. Richardson, Elmira.  
C. W. Fairfax, Geneva.  
Otis W. Sherman, Poughkeepsie.  
Russell A. Field, Brooklyn.  
N. L. Bates, Oswego.  
J. J. Worrell, New Brighton, S. I.  
B. Van Tuyle, Rochester.  
I. G. DeCant, Watertown.  
A. B. Barkman, Tarrytown.

### OHIO.

F. W. Work, Akron.  
Harry D. Crane, Cincinnati.  
Charles J. Forbes, Jr., Cleveland.

F. T. Cuthbert, Lima.  
G. E. Mentel, Springfield.  
George L. Fordyce, Youngstown.

### PENNSYLVANIA.

Stedman Bent, Philadelphia.  
Philip S. Flinn, Pittsburg.  
W. O. Davis, Erie.  
Jacob D. Rider, Lancaster.  
J. Sidney Sible, Harrisburg.  
H. C. Harbach, Philadelphia.  
Dr. E. C. Wagner, Wilkesbarre.  
T. J. O'Neill, Hanover.  
Dr. W. R. Stephens, Wilkesburg.

### TEXAS.

Eugene Corley, Dallas.  
C. J. Overman, San Antonio.  
S. E. Bering, Houston.

### VERMONT.

W. W. Brown, Springfield, Vt.  
C. C. Warren, Waterbury.  
Charles A. Matthews, Rutland.

### VIRGINIA.

Otis M. Alfriend, Richmond.  
Frederick Lewis, Norfolk.

### WEST VIRGINIA.

T. J. Westmyer, Wheeling.  
X. Poole, Martinsburg.

### WISCONSIN.

Dr. Louis Fuldner, Milwaukee.

### The Publications Board and Its Constituents.

Coincident with the announcement of the appointment of the Legislative and Touring Boards, the following were named as members of the Publications Board for the ensuing year:

A. G. Batchelder, chairman, New York City.  
John C. Kerrison, Boston, Mass.  
Russell A. Field, Brooklyn, N. Y.  
John C. Wetmore, New York City.  
T. B. Creamer, Philadelphia.  
W. F. Thomas, Newark, N. J.  
Arthur N. Jervis, New York City.  
W. S. Gilbert, Cleveland, O.  
C. F. Fitzgerald, Daytona, Fla.  
L. C. Boardman, Chicago.  
L. P. Baekey, Philadelphia.  
G. A. Wahlgreen, Denver, Col.  
R. R. L'Homedieu, San Francisco.

### AERO GORDON-BENNETT STARTS OCTOBER 11.

BERLIN, Feb. 27.—The date of the Aero Gordon-Bennett has now been definitely fixed upon for October 11. This is a Sunday. On the day preceding, Saturday, two other races will take place, open only to members of the German Airship Association, which has the arrangement of the chief event.

## ORMOND-DAYTONA RACES IN FULL SWING

By JOHN C. WETMORE

ORMOND, FLA., March 1.—Though the past glories of the Ormond-Daytona beach meets so far as big fields and multitudes of spectators will not be received this year at the present writing at noon on Sunday, indications point to a limited but high class array of starters with a probable minimum of six in each of the four long-distance races carded for the week. At least the Automobile Club of America can claim the credit of not letting the annual tournament go by the boards, and by hard hustling having gathered a sextette of racers likely to put up on the smooth beach new records for all distances of 100 miles and over.

The array of fast ones already on hand is noteworthy. Walter Christie has his Big Bear, with a 35-second mile record on Atlantic City beach; and the 60-horsepower Christie he drove in the last Vanderbilt Cup race. E. B. Blakeley will pilot the former and Christie himself will drive the latter. Emanuel Cedrino is here with the Fiat Cyclone, built on Grand Prix lines, and Maurice Bernin with a new 60-horsepower Renault Frères.

A new racing enthusiast, R. W. Buckley, of Brooklyn, shies his caster into the arena at this meet. He bought the 120-horsepower B. L. M., completed too late for the last Vanderbilt Cup trials, and will drive it in the big race and the invitation contest. He will also enter and drive his 70-horsepower Thomas runabout in the stock car race. The 120-horsepower Vanderbilt Hotchkiss, to be driven by F. B. Shaft, is en route, as is also a 60-horsepower Haynes, to be piloted by R. G. Kelsey. The former is nominated by Harry Levey, of New York, the cleansing magnate. This about completes the list of probable starters or those likely

to figure prominently in the big race. Other candidates for stock car, Minneapolis Cup, and invitation race honors are a 60-horsepower Benz, entered by Louis Bergdol, of Philadelphia, which G. P. Parker will pilot; James Loughlin, 3rd's 30-horsepower Cleveland; Joseph W. Gilbert's 30-horsepower Packard, and a Franklin, entered by Mr. Stimson, of Jacksonville.

Ormond never put up a balmier line of weather than the present; but—alas!—the condition of the beach is most disappointing. Between Ormond and Daytona there are so many soft spots of red sand that it is probable that none of the races, except perhaps the stock car contest, will be run over this end of the beach. South of Daytona, however, the beach is fairly good and likely to admit of new long-distance records by the very fast bunch of contenders at hand. It is likely that a 12 1-2-mile stretch will be laid out and the races run in 25-mile circuits of 300, 150 and 100 miles.

The races will be conducted by Chairman Robert Lee Morrell, A. L. Riker, A. R. Whiting and S. B. Stevens; all but the latter are already here. They will be assisted by F. J. Wagner, as starter; George L. Weiss and Lieut. P. A. Sayles, as timers; and Secretary S. A. Butler, as indispensable man of all work.

Among the other racing enthusiasts here for the meet are: Mr. and Mrs. Joseph M. Gilbert, Mrs. A. L. Riker, Mrs. Buckley, Mr. and Mrs. A. W. Church, E. R. Hollander, N. Lazarnick, W. A. Adriance, E. A. Percy, E. C. J. McShane, Harlan W. Whipple, A. R. Hawley, R. A. Field, Mr. and Mrs. W. H. Harrison, F. Ed. Spooner, and W. A. Rutz. The hotel is crowded with a big overflow in the cottages in the grove.

### FEW STARTERS IN OPENING DAYS' EVENTS

ORMOND, FLA., March 3.—No record was broken when Emanuel Cedrino, in the Fiat *Cyclone*, captured the Minneapolis Cup on the opening day of the sixth annual speed carnival. The light track racer recently imported from Italy covered the hundred miles in 1:50:20, running the last sixty miles on three tires and a rim. The record made in 1906 by Clifford Earp on a Napier is 34:40 better.

To the disappointment of the large crowd of spectators, but three cars lined up for the start of the 100-mile race: Blakely, on W. Gould Brokaw's 130-horsepower front drive Christie; Shefts, in Harry Levey's 120-horsepower Hotchkiss; and Cedrino in the Fiat. The start was made at the twelve-mile post in front of the clubhouse at Daytona, and was run over a twelve and a half-mile stretch.

The Hotchkiss got away first, but was soon passed by the Fiat, and before the French car had gone a mile its chances had been lost by a long delay caused by clutch trouble. The Christie had difficulty with its automatic inlet valves, after covering ten miles, and ceased to figure in the contest. The Fiat lost time through a front tire pulling off the rim on two different occasions, the mishap allowing the Hotchkiss to creep up to within five miles of the Italian. At the 50-mile mark, however, the Fiat had a substantial lead, its time being 64:05, compared with 1:17:51 for the Hotchkiss. The French car later withdrew, leaving the Italian alone for an uninteresting finish. The Fiat carried off the special prize of \$100 offered by the Continental Caoutchouc Company for the fastest car fitted with their tires and racing rims.

Though faster time was made by the German Benz, winner of the 150-mile stock chassis race, the afternoon event was

no more interesting than that of the morning. Louis J. Bergdol, on the 80-horsepower Benz, covered the first 25 miles in 25:15, being then ahead of the morning time; the 50-mile mark was passed at 61:02; 125 miles at 2:10:38, and the winning post at 2:40:53.

The four starters were W. Gould Brokaw's Allen-Kingston, James Laughlin's Cleveland, a Thomas Flyer, driven by J. Carey, and L. J. Bergdol's Benz. The only withdrawal was the Haynes, which had previously broken its crankshaft. A good start gave the Benz a lead, which it easily maintained to the end. At the twenty-five-mile mark the Thomas was second and the Cleveland third. The Allen-Kingston retired early with burned-out bearings. Summary for first day:

**100-Mile Race for Minneapolis Cup.**—Won by Cedrino, 80-horsepower Fiat "Cyclone"; time, 25 miles, 26:39 4-5; 50 miles, 60:05; 75 miles, 85:06; finish, 1:50:20.

**150-Mile Stock Chassis Race.**—Won by Bergdol, 80-horsepower Benz; time, 25 miles, 25:15; 50 miles, 61:02; 75 miles, 85:32; 100 miles, 1:47:31; 125 miles, 2:10:38; finish, 2:40:53.

#### Benz Victory Feature of Second Day's Racing.

ORMOND, FLA., March 4.—Over a vastly improved beach, Louis J. Bergdol, driving an 80-horsepower Benz, to-day won the 125-mile invitation amateur race in 1:53:30 2-5, cutting his new record figure of yesterday. S. B. Stevens, in the Fiat *Cyclone*, was second, covering 95 miles in 1:54:28, after losing 29 minutes waiting at Daytona for a new rocker arm to be brought from Ormond. Stevens led with 41:37 for 50 miles and 50:18 for 70 miles, at which point he was four miles ahead of the German car. R. G. Kelsey, who was third, was last timed at 50 miles in 1:05:46. The race was run over a 50-mile course at the Daytona end of the beach.



Escorting Italian Through Snowdrifts Into Chicago.

**WORLD TOURISTS PROTEST AND SQUABBLE.**

Dissensions have arisen among the group of men trying to cover the 20,000 miles between New York and Paris by automobile. The two foreigners forming the rear guard complain that they are being badly treated along the road, and the crews of the two leading cars have put in a protest against the only American, declaring that it was rebuilt at Buffalo and had received help in the run through snowbound Indiana. Thomas emphatically denies the charges.

The crew of the De Dion car, *Le Matin's* official automobile, have quarreled among themselves. Captain Hansen, a Norwegian explorer selected by the De Dion Company to pilot the car, was unable to agree with Saint-Chaffray, the *Matin* delegate, and quit at Chicago. The rupture is not surprising, for at the start in New York there was little harmony between the *Matin* official and the drivers of the French cars.

Captain Hansen has now made arrangements with the E. R. Thomas Company to take their car through to Paris. He will probably join the car when it reaches Cheyenne, Wyo., at which spot Roberts will turn it over to some other driver. It had at first been intended to send the Thomas car as far as San Francisco only; now, however, that Hansen has been secured, it will be sent by train from Cheyenne to Seattle on March 5, in company with the foreigners, its equipment completed, and driven through Alaska and Siberia to Paris. The prospects of the American car reaching Paris have been enormously increased by this move, for Captain Hansen is the only man who has had actual experience in Arctic regions, and was selected by the De Dion Company as the most capable man Europe could provide.



How the De Dion Team Looked on Reaching Chicago.

Thomas, De Dion and Zust have left Chicago and are now on the second leg of the journey, struggling with Iowa mud. The Thomas is leading, the De Dion and Zust keeping as close together as possible over one hundred miles in the rear. The German Protos and French Motobloc have also formed an alliance, and will probably set out from Chicago together after a brief rest and overhauling of their machines. It is not likely, however, that they will continue far, for, according to an agreement, all cars must be put on the railroad on March 5 in order to arrive at Seattle in time to catch the last boat to Valdez, Alaska. Many who are familiar with conditions in the Northern regions believe that even with this saving of time it will be impossible to get through Alaska before the thaw transforms the country into a huge bog and makes travel impossible. It is to avoid such a hold-up that the cars are to be rushed ahead on the railroad instead of continuing across country under their own power.

The mileage of the different cars from the thirteenth day to date is as follows:

Car	Country	14th Day	15th Day	16th Day	17th Day	18th Day	19th Day	20th Day	21st Day
Thomas (America)	....	1043	1043	1043	1118	1227	1297	1395	1502
De Dion (France)	.....	987	1043	1043	1043	1117	1212	1263	1263
Zust (Italy)	.....	987	1043	1043	1043	1117	1212	1263	1269
Protos (Germany)	.....	912	932	949	963	981	993	993	993
Motobloc (France)	....	895	921	949	963	981	985	993	1043



Not Snowbound—Only Rushing Studebaker Through to Kansas.

**STUDEBAKER ACCOMPLISHES WAR MISSION.**

Starting out from New York six days after the New York-Paris tourists, the Studebaker army car passed the leaders in the round-the-world run before Chicago and presented its dispatch to the Governor of Fort Leavenworth, Kansas, Tuesday, March 3. The 1,500-mile run which had been undertaken to prove the value of the automobile as a factor in military operations, was beset with enormous difficulties owing to the wretched condition of the roads and the heavy snowdrifts encountered for a considerable portion of the distance. Relays of drivers were employed, the men being sent ahead by train to await the car's arrival; in this way the machine was kept running twenty-four hours a day.

**Studebaker-Pullman Run to Savannah.**

PHILADELPHIA, March 3.—With Robert Morton and Frank Yeager at the wheels, a Pullman and a Studebaker left this city this morning for an endurance run to Savannah, Ga., on a wager of \$1,000, which will be awarded to the driver first reporting to the Savannah Motor Club. The run is being held under the auspices of the Quaker City Motor Club, Dr. J. E. Overeck and G. W. Daley being the official observers. The route is via Reading, Harrisburg, Gettysburg, Washington, Richmond, Portsmouth, Danville and Columbia.

## MARCH DOINGS OF THE AUTOMOBILE CLUBS

### BANQUET OF THE A. C. OF PHILADELPHIA.

PHILADELPHIA, March 2.—Upwards of one hundred members and guests gathered in the huge banquet hall of the Manufacturers' Club last Friday evening on the occasion of the annual dinner of the Automobile Club of Philadelphia. Many out-of-town guests of prominence were present, and the tenor of the addresses was so hopeful for better things for the automobilists that all hands voted the symposium the most successful and enthusiastic ever held under the club's auspices.

The various elements now quietly at work for the improvement of the roads between Washington and New York—all had representatives present, and the reports of the work already accomplished were evidently gratifying to those assembled about the board.

Robert P. Hooper, chairman of the Good Roads Board of the A. A. A. and vice-president of the Pennsylvania Motor Federation, urged the concentration of all local clubs and individual automobilists upon the matters of good roads, better laws and signboards. He urged all automobilists to prod their representatives at Washington to do all in their power to aid the passage of the Federal Registration bill, now pending in Congress, and upon which a hearing will be given next week.

In the unavoidable absence of Mayor Reyburn, his Director of Public Safety, Henry Clay, was on hand to say a word of welcome to the visitors and outline the city's attitude toward automobilists.

Colgate Hoyt, president of the Automobile Club of America, spoke of the great advance in automobile construction, and instanced the recent Long Island economy test, where the winning car carried its passengers over 242 miles of road at a cost per head for fuel and oil of but 71 1-2 cents, whereas a round trip railroad ticket costs \$5.38.

In the capacity of toastmaster, Secretary S. Boyer Davis made many hits. He thought the Automobile Club of Philadelphia deserved credit for its good roads and signboard work and its membership of over 525, and predicted twelve months hence a total on the rolls which would make a membership of one thousand a possibility before the completion of the following year.

### MARYLAND OFFERS AUTO CORPS TO ARMY.

BALTIMORE, Md., March 5.—Developing the original idea of the Quaker City Automobile Club to endow the nation with Volunteer Motor Corps as part of the militia, the Automobile Club of Maryland has forwarded resolutions to the President of the United States, Congress and the General Assembly of Maryland.

The value of the automobile as an auxiliary in military operations having already been fully demonstrated, the Maryland club recommends to the Congress of the United States that it provide by appropriate act or acts of Congress for the organization, arming, and disciplining of Volunteer Motor Corps as part of the regularly organized militia of the several States. The club offers to both Federal and State governments the service of so many of its members and their automobiles as may be necessary for the organization of a Volunteer Motor Corps in the home State in the event of the adoption of the resolution.

In case the recommendation is not adopted, and the proposed corps is precluded from becoming a branch of the State militia, the club offers to form a volunteer corps and place it at the services of the city of Baltimore and the United States government in all cases of need or necessity.

### TOLEDO CLUB TAKES AN ACTIVE ROLE.

TOLEDO, O., Feb. 10.—While Ohio is one of the later States to develop an active participation in the good roads movement, much work has been accomplished there within the past year. The most recent addition to the good roads army in the Buckeye State is the newly-organized Automobile Club of Toledo, which has leased quarters in the new Hotel Secor, and has gone at its work in an aggressive manner, plainly indicating that it will be a potent factor.

The club is made up of men who are identified with the various professional and business interests of the city, and an important factor in the promise of success that this club shows can be found in the officers elected to guide affairs.

E. D. Libbey, the president, is well-known as a manufacturer of cut glass, and also as the exploiter of bottle-blowing machinery that has revolutionized that industry. He is an intensely enthusiastic autoist and every summer tours through Europe. He is prominently identified with the social,



E. D. Libbey, President. E. J. Marshall, Vice-President. A. L. Spitzer, Secretary. J. M. Steenberg, Treasurer.

business, and club life of Toledo, and among his many interests is that of president of the Toledo Museum of Art. E. J. Marshall, the vice-president, is a prominent corporation lawyer, identified with the automobile industry, and is himself an enthusiastic automobilist. A. L. Spitzer, the secretary, is a member of Spitzer & Company, bankers, of Toledo and New York, and has been a good roads advocate for years. J. M. Steenberg, treasurer, has been foremost among local autoing devotees ever since the rise of the sport.

These men, with John J. Manning, Marshall Sheppey, W. W. Morrison, John N. Mockett, and F. M. Brigham, constitute the board of governors. The club anticipates building an up-river clubhouse and already steps have been taken to put the roads around the Maumee and Perrysburg belt drive in perfect condition for automobiling.

### TWO ACTIVE VIRGINIA AUTOMOBILE CLUBS.

RICHMOND, VA., March 2.—The Richmond Automobile Club was organized in October and has about seventy members. There are about 200 autos owned in Richmond. The officers of the club are: President, Dr. R. Angus Nichols; vice-president, John B. Swartwout; secretary-treasurer, Otis M. Alfriend. The club hopes to join the A. A. A. in the near future. At present they are working to secure the passage of a bill before the Legislature, which will give State aid in roads building. The club also plans to have some local races and endurance runs.

There are a number of accessible places within a radius of twenty miles of Richmond, but no extended trips can be made with comfort because of the poor highways.

The Valley Motor Club, of Virginia, has headquarters at Staunton, Va. The officers are: President, M. C. Watts; vice-president, C. S. Hunter; secretary, E. R. Armentrant; treasurer, Frank T. Holt.



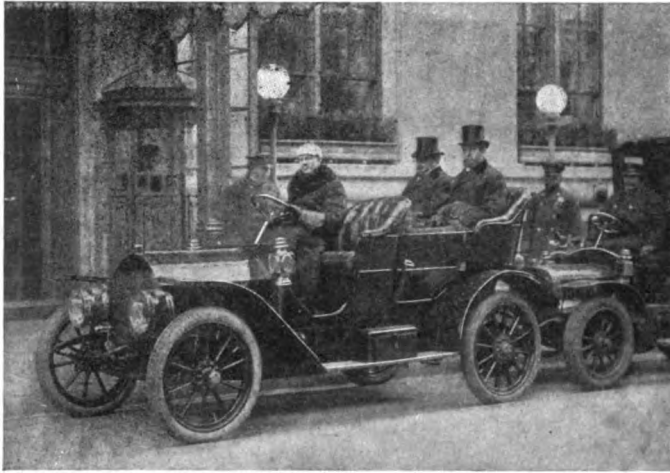

Governor Hughes Utilizes the Premier.

New York's governor appreciates the value of the automobile as a means of keeping numerous engagements in an evening, and is shown here on the occasion of a lecture trip in the metropolis.

### SUCCESS OF ROCHESTER AUTO SHOW ASSURED.

ROCHESTER, N. Y., March 2.—Every space is taken for the first annual Rochester automobile show to be held March 18-21 inclusive. Owing to the large number of applications for space since the last were sold the management is making arrangements for additional space, which will be in the foyer and basement. Every inch of space on the main floor is taken up with automobiles, while the large platform built for the accessories in the balcony is crowded to its limit, all the committee rooms are being used for exhibiting purposes. The New Convention Hall, where the show is to be held, is rapidly nearing completion and will be in readiness for the opening night, which will be the official opening of the building. The entire fifteen dealers in automobiles in the city will show, as will the two manufacturers, the Gearless and the Selden. The accessories, motor boats and motorcycles will all be shown by local dealers, making it an entirely local show. Great plans are being laid for the decorations, which will be a leading feature of the exhibition. It will be a color scheme of green and white, with an electrical display of nearly 15,000 lights arranged for decorative purposes. The Fifty-fourth Regiment band will furnish music.

### INDIANAPOLIS SHOW WEEK OF MARCH 23.

INDIANAPOLIS, Feb. 24.—At a meeting of the Automobile Show Committee, held at the Denison Hotel last Wednesday night, it was decided to postpone the automobile show for one week, the new dates beginning March 23.

After considerable discussion it was decided to make the change so that the show and the annual conclave of Scottish Rite Masons could be held at the same time, insuring a larger attendance.

The hill climb will be held on the morning of March 24 on Michigan Hill, which is the steepest and most dangerous hill in the vicinity, if proper arrangements can be made. A silver loving-cup will be presented to the winner of each of the following events: Cars listed at \$1,000 and under; cars listed from \$1,000 to \$1,800; cars listed from \$1,800 to \$2,750; cars listed from \$2,750 to \$3,500, and for cars listed above \$3,500. There will be a parade of the contestants.

### APPERSON WINS PASADENA HILL CLIMB.

LOS ANGELES, CAL., Feb. 29.—Remarkable time was made to-day in the feature event of the annual Pasadena-Altadena hill climb by the Apperson Jackrabbit which speeded up the 1.4-10-mile incline at the rate of 52.4 miles per hour, defeating such high-class competitors as the Stearns, Franklin, Packard, Pope-Toledo and Haynes. The grade is said to be 11 per cent., and the Apperson had 18 seconds to spare over its nearest competitor. Winners in the other events were the Thomas Flyer, Oldsmobile, Pope-Hartford, Kisselkar and Tourist.

### RECEIVER FOR MERCEDES, BACKED BY MORSE.

Temporary receivers have been appointed for the Mercedes Import Company, a wholesale automobile concern with offices and salesrooms at 590 Fifth avenue, and Charles W. Morse as its financial backer. Recently C. L. Charley, sole selling agent for the German Mercedes Company, became uneasy about the condition of the company and sent his brother from Paris to investigate. The largest creditors are C. L. Charley, \$43,800; Charles W. Morse, \$25,000; National Bank of North America, \$55,479; R. E. Fulton, \$6,300. The total liabilities are \$115,104, and the nominal assets \$146,978.

### NEW PACKARD "CLOSE-COUPLED" BODY.

Owing to the varying accommodations required by different purchasers of a car, the selection of types of bodies has been a difficult problem for the maker. Many owners exact from a car, greater carrying capacity than was provided for in its design and this has been the case particularly with runabouts, out of which has grown the odd-looking roadster type with two seats on the extreme rear. Appreciating the demand that exists for a four-passenger car, the owner of which usually drives himself, while the chauffeur is carried in the rear, the Packard Motor Car Company, Detroit, Mich., has just brought out the "close-coupled" body shown in the accompanying photograph. This body is mounted on the regular Packard "Thirty" chassis and has been especially designed for the purposes in view, providing comfortable seats for all four passengers, as contrasted to the runabout on which the rumble is far from comfortable.

In this new design, the passengers are carried midway between the front and rear axles, so that their weight is well distributed on all four springs, and a variation in the load is not so perceptible. It is a particularly safe and capable car for fast driving over rough roads, as the distribution of the weight is such as to give the maximum efficiency under all conditions. The rear end of the body provides storage space for touring paraphernalia. With the new body, the Packard "Thirty" lists at \$4,300, or \$100 more than the regulation touring type.

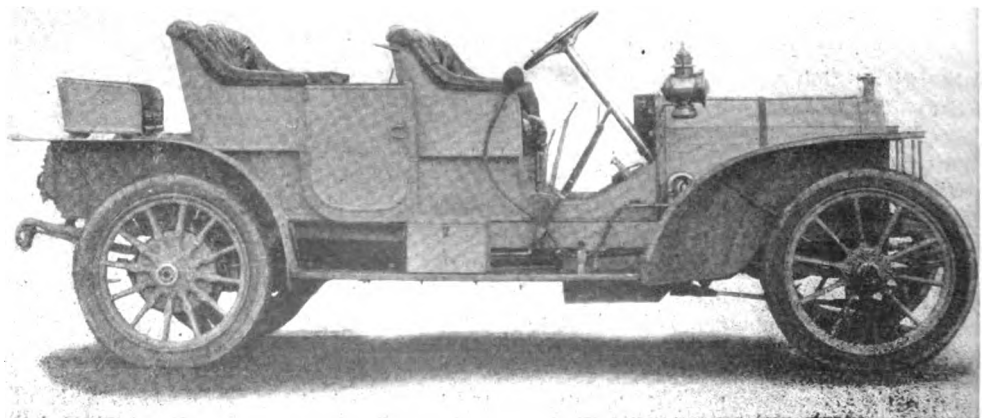

Attractive Lines of the New "Close-Coupled" Packard.

## BRIEF ITEMS OF NEWS AND TRADE MISCELLANY

Springfield, Mass., is to have a combination automobile hose and chemical wagon, and when it goes into service, the city will have no less than five automobile fire wagons, the others being two "flying squadrons," a chief's and deputy chief's car.

Josef Hoffman, the well-known pianist, has bloomed forth as the inventor of an ingenious road indicating device, which has been patented in Germany and upon which patents are now being applied for in this country, through his attorneys, Howson & Howson, New York.

J. D. Lamb, president of the Inland Auto Company, Walla Walla, Wash., and L. H. Thoen, one of the company's representatives, are at present on a tour through their Washington and Idaho territory and report excellent prospects for the season. The concern handles the Franklin line.

Since the new Rambler models were placed on the market in November last, 1,379 cars have been sold, the makers announcing that their December sales exceeded by \$23,900 those of the same month in any previous year, while January showed an increase of \$18,148 of the same kind, something strongly indicates the generally healthy condition of the auto business.

Fire Chief Lally, of the Brooklyn fire department, is enthusiastic over the service given by the Stolp Shock Eliminator on his Locomobile which has now been equipped with the device for several months. He reports that it has given satisfactory service and has required no repairs or adjustments, and that its use effects a great saving in wear and tear on the machine.

With thirteen bidders for the privilege of supplying the city of Camden, N. J., with a runabout for the use of Chief Hollinsworth, of the Bureau of Water, for inspection purposes, the contract was awarded to the Mitchell car. The Philadelphia agents, the Penn Motor Car Company, aver that there is nothing in the silly superstition regarding the unluckiness of the number 13.

Owing to the great increase in their business during the past year, the Autolight & Motor Supply Company, 506-508 North Broad street, Philadelphia, has had to add to its facilities and has just completed a large addition to its building at the above address. This company carries one of the largest and most varied stocks of automobile supplies and accessories and issues an attractive catalogue.

A. P. Fleming, secretary of the Automobile Club of Southern California, has just taken delivery of a new roadster type of Durocar with inclosed body, this being the first 1908 model built in Los Angeles to be completed. It is the product of the Durocar Company, and was built specially to Mr. Fleming's order. Though intended principally for city use, the car has a speed of forty miles an hour and will be used for tours as well.

It has been suggested to Alexander Winton that he rehabilitate the *Bullet No. 2* and enter it in the speed contests of the coming summer. One of the enthusiasts making the suggestion declared that no racing machine had appeared since its manufacture in 1903 that looked faster or more trustworthy. Earl Kiser, now Winton branch manager in Pittsburg, hopes Mr. Winton will decide to start the *Bullet* once

more, for the champion steersman is keen for fresh contests on the track or road.

The New York branch of the White Company has recently sold an ambulance to the Kings County hospital of Brooklyn. The ambulance consists of a standard 30-horsepower chassis with a body similar to those of the ambulances furnished by the White Company to the United States War Department and Navy Department. The suitability of the White for ambulance work has been highly commended by the Quartermaster-General in a formal report on the subject to the Secretary of War.

American methods of automobile manufacture are soon to be tested by the Royal Automobile Club of Great Britain, the technical committee of which will select three single-cylinder Cadillac cars from the London agents' stock. These cars will be dismantled and their parts mixed indiscriminately. The committee will then single out the pieces into three separate piles and the company's mechanics will rebuild the cars from them, without altering any of them, and with nothing but spanners as tools. Upon being reassembled, the three cars are to be run 500 miles on the Brooklands track.

The latest move on the part of an accessory manufacturer to "automobile row" has been that of the Witherbee Igniter Company, located for the past three years at 541 West Forty-third street, New York, soon to be installed in new quarters on the third floor of the Motor Mart, 1876 Broadway. In its new location the company will have more than 8,000 square feet of floor place, thus affording more room for the manufacture and display of Wico ignition specialties. The general offices and sales-room face Broadway, while the factory and charging room occupy the remainder of the space. A. J. Fisk, general manager of the company, is now on an extended trip through the West, establishing a complete chain of branches. A. B. Elliott, the company's vice-president, promises a unique house-warming as soon as the new quarters are ready.

### RECENT TRADE REMOVALS.

The Supplementary Spiral Spring Company, of St. Louis, manufacturer of the "Spring of Fame" supplementary springs, has removed its New York office from 52 West Sixty-seventh street to the Motor Mart, 1876 Broadway. M. H. Cormack, formerly vice-president of the Standard Brake Company, is in charge of the office, and his territory includes the States of New York and New Jersey.

### NEW AGENCIES ESTABLISHED.

The Schacht Manufacturing Company, Cincinnati, O., have just opened an agency at 1402 Michigan avenue, Chicago. It is in charge of Walter S. Crain, who has long been identified with the automobile industry. A full line of the Invincible Schacht runabouts will be shown.

Following up the aggressive agency campaign upon which he has been busily engaged for some time past, Paul Lacroix has just announced the placing of a Boston agency for the Renault cars. The new representatives at the Hub are A. Cutler Morse & Company, located in the Motor Mart, Park Square, Boston, Mass.

Agencies for the friction-driven Carter-car are being closed all over the country, some of those who have taken on this line within the last few weeks, being as follows: Smith, Clemens & Hopping, Dayton, O.; Knowles & Roland, Demming, N. M.; Parker & Heugabaugh, Ashtabula, O.; Indianapolis Auto Company, Indianapolis, Ind.; Naperville Garage, Naperville, Ill., and Johnson's Auto Company, Boone, Ia.

### PERSONAL TRADE MENTION.

Lewis C. Block, of the Ford, Buffalo (N. Y.) branch, has succeeded F. C. Vanderhoof as manager of the Philadelphia branch of that company. The latter has accepted the management of the Bergdoll Motor Company, of Philadelphia. The Philadelphia branch will shortly be moved nearer to the center of activity on "Gasoline Row," the change only awaiting the completion of a new building now being erected at Broad and Vine streets.

L. J. Sackett, a pioneer auto salesman, has just joined the Matheson forces as special representative and at present is at the Matheson plant at Wilkesbarre, Pa. Mr. Sackett is probably one of the best qualified salesmen in the field, as he has not only had a number of years' experience and is known from coast to coast, but he has also had considerable experience and education in the practical end of automobile building, so that he can run and repair cars as well as sell them.

### NEW TRADE PUBLICATIONS.

Something of interest on the subject of tire construction is to be found in the publication of the Dow Tire Company, 104 West Forty-second street, New York City, makers of the Dow non-deflation tubes. Colored illustrations reveal the construction of the tire and methods of production.

Of particular interest in the catalogue of the Anderson Forge and Machine Company, Detroit, Mich., is the section devoted to vanadium steels and the tables showing results of tests made. Drop forgings, which form the main feature of the company's output, are also dealt with somewhat extensively.

Small in size, but complete in information, is the characteristic of the booklet dealing with the improved models of Stewart speedometers, produced by the Stewart & Clark Manufacturing Co., of Chicago. The salient features of the Stewart are well presented between the red covers of the little booklet.

In the Reliable-Dayton 1908 catalogue details are given on what is claimed to be the "first real successor to the horse." Four models, three of them of the buggyabout type and one a delivery wagon, are produced by the Reliable Dayton Motor Car Company, Chicago, and their main features are set forth in the catalogue.

Those interested in what an automobile can do with the bonnet sealed down hard and fast will find something to please them in a small brochure from the Mora Motor Car Company, of Newark, N. Y. Press comments on what was probably the most extensive sealed bonnet contest ever run off constitutes the main portion of the booklet.

**INFORMATION FOR AUTO USERS**

**"Oilzum" Carbonless Oil.**—Under this title, the White & Bagley Company, Worcester, Mass., are manufacturing a special brand of cylinder oil, particularly refined for gas engine use. It is intended as a lubricant for the piston, wrist pin and main bearings, and its



"OILZUM" SPECIAL CYLINDER OIL.

makers claim that it will keep the cylinder head and piston rings free from carbon for the longest period of steady service. The same concern is also placing on the market a special automobile



"CLEANZUM" DIRT REMOVING COMPOUND.

soap known as "Cleanzum Antiseptic Hand Cleaner" which will instantly remove oil and grime from the hands without injury to the skin. They will show a full line of their products at the coming show in Boston next week.

**Smith Taximeters.**—S. Smith & Sons, Ltd., 9 Strand, London, Eng., the well-known English makers of the Smith Speed Indicators, have just placed a new taximeter on the market. It has been in constant use by the London municipal authorities for the past three months and has also passed the Scotland Yard test successfully, besides receiving a certificate from the observatory at Kew for accuracy. The instrument is 8 inches high, 7 inches wide and 5 inches deep. It is operated on the well-known horo-metric system, i.e., showing the amount of fare according to the time occupied or distance traveled, the dial indicating total fare and extras. The Smith taximeter is of extremely simple construction and although substantially made throughout weighs but 15 pounds. The clock movement is of the two-day type and

is of S. Smith & Sons make. The usual flag is provided to show when the vehicle is at liberty, and by means of a lock for which the driver carries the key the instrument may be made proof against tampering by the mischievous small boy. The wheel attachment is very simple, an arm actuated once at every turn of the wheel pulling a wire concealed in a flexible shaft and moving the driving wheel of the taximeter one tooth. This causes the working to be very slow, with a consequent absence of wear. The Smith taximeters are being placed on the American market by the firm's branch house, located at 116 Broad street, New York.

**"Wisconsin" Tire Protector.**—One bad feature of many tire protectors is the constant tendency to loosen that they exhibit in service. This is a feature that has been given special attention in the "Wisconsin" tire protector, which is being manufactured and marketed by the Tire Protector Company, Stevens Point, Wis. The general construction of the protector will be plain from the

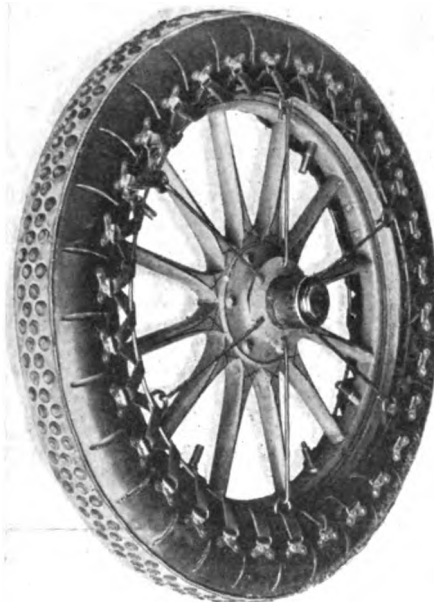

ATTACHMENT WISCONSIN TIRE PROTECTOR.

accompanying illustration, the method in which the defect in question is overcome consisting of the use of six loops in the continuous circular wire to which the hub connections are attached, as shown. The wire is hard steel and the tendency of the loops is to spring back straight, which causes them to exert a tightening effect upon the protective cover, drawing it closer to the tire. The base of the protector is made of rubber and fabric, while the tread is of the best chrome leather studded with rivets upon which the wear comes. This construction prevents the stretching and bagginess that is inevitable with protective covers made of leather alone, while any slackness from wear and service is automatically taken up by the steel wire ring already mentioned, and to which the protector is laced all the way round. As an instance of the durability of this rubber and leather combination, it may be mentioned that one set has been run

more than 4,000 miles in the past 18 months and is still in excellent condition. During that time the tires were never punctured.

**K-W Special Magneto.**—In order to meet the constantly increasing demand for a magneto within the reach of owners of small cars, the K-W Ignition Company, 34

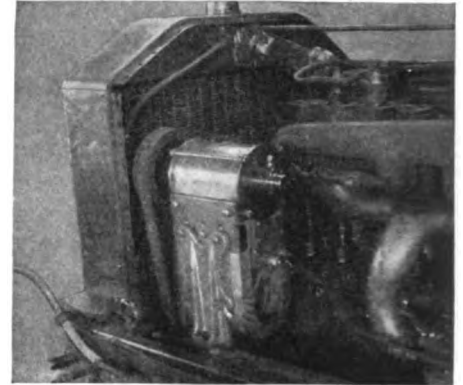

K-W SPECIAL MAGNETO ON FORD.

Power avenue, Cleveland, O., have just brought out a new magneto, known as Model F, which has been designed especially for use on the four-cylinder Ford runabouts, but which can be used on any automobile. The accompanying illustration shows the manner of installing it on a Ford, a substantial bracket being furnished by the makers for this purpose, the magneto being mounted by attaching this bracket to the frame of the car. It is equipped with a pulley for driving from the flywheel by means of a one-inch belt, and to avoid trouble from the use of the common article the makers will supply a non-stretching, waterproof belt at a cost of \$1. The K-W magneto has been wound especially for use in connection with the coils employed on the Ford cars and a large number of them have been sold for installation on the latter.

**The Crane Puller.**—Nothing so emphasizes the value of a tool as the number of uses to which it may be put in case of emergency, and this is something for which

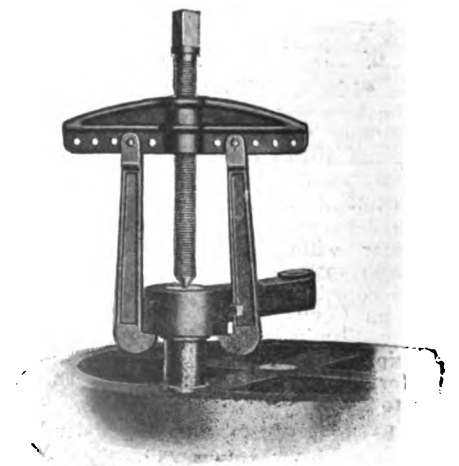

ONE METHOD OF USING CRANE PULLER.

the Crane puller, made by Crane Puller, 53 State street, Boston, is specially designed. It may be used as a jack, for removing

sprockets and wheels and for many uses in the repair shop, such as removing a fly-wheel, or as an arbor press, while many other uses will suggest themselves to the ingenious amateur or repairer. These tools are made in several sizes, the No. 2, provided with two sets of arms, long and short, being especially designed for the use of the autoist. The beam is 10 inches long, and the long arms are 9 inches long in the clear, while the short arms serve to pull off anything under a length of 6 inches. The total weight of the tool is 12 pounds and it is guaranteed to stand a strain of six tons.

**Herz Tandem Pump.**—The constantly increasing size of automobile tires has made the task of pumping them by hand burdensome, and a number of tire pumps have been placed on the market, but the average autoist prefers not to have a pump permanently installed on the car. To avoid this objection, Herz & Company, 203-205 Lafayette street, New York, are placing on the market a hand lever flywheel-friction type of pump known as the "Tandem." It is adapted to "knock down" for packing in the tool box, and for use merely has to be held against the frame of the car and pressed against the revolving flywheel. The same concern also makes the well-known "B.B.," which is a double piston type designed to be attached to the frame and driven by gear, chain or belt. The Herz distributor is another of their specialties that has been on the market for several years. In this, the primary contact is of the press type, and occurs between two hardened tool-steel pins, pressed against each other by

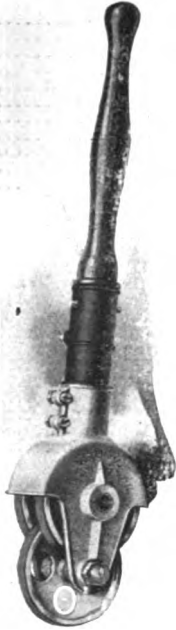

TANDEM PUMP.

street, New York City. As will be seen by accompanying illustration the protector consists of a heavy, porcelain hood, screwed on to cable and securely held by spring socket. While making a hermetically sealed connection, the hood is easily removed.

**Marine Spark Plug Protectors.**—All motor boat owners who have suffered the petty annoyance caused by water reaching the spark plug will appreciate the protector produced by A. R. Mosler & Company of 163 West Twenty-ninth

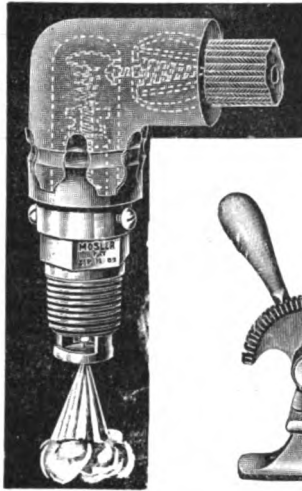

PLUG COVER.

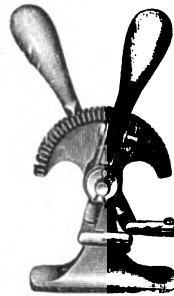

MOSLER CONTROLS.

The same firm has recently placed on the market a new distributor for operating multiple cylinder engines with a



MOSLER SINGLE-CYLINDER DISTRIBUTER.

single vibrator coil. One of its most valuable features is a patent separable case allowing immediate access to primary contacts without removing wires. At the same time the primaries are absolutely water and dust-proof. The secondary terminals are carried by hard rubber casing and heavy plate glass. Mosler self-clamp controlling and cut-out levers for use on automobiles and motor boats are a simple and reliable attachment made with either single or double levers and built for either horizontal or vertical control.

**New Harris Spout Cans.**—While nothing can be of greater importance than the provision of proper lubricating oil for the automobile motor, the necessity of having it in a suitable container for the convenience of the user is a matter of no little import to the autoist. The A. W. Harris Oil Company, Providence, R. I., realizing this, brought out a new line of cans this year and the favorable reception with which

they have met shows conclusively that the manufacturers' efforts in this direction have been appreciated. The Harris one-gallon can is a decorated package bearing the word "Light," "Medium" or "Heavy," designating the grade of oil, and is equipped with an extension spout, which is held on top dur-

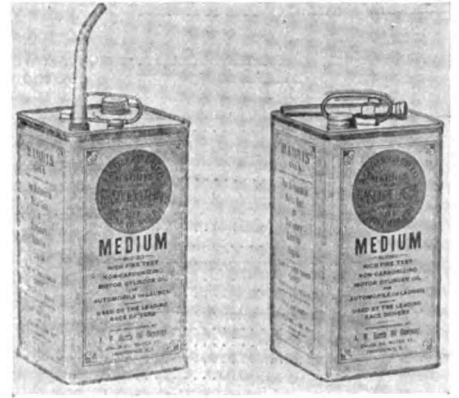

HARRIS CAN WITH EXTENSION SPOUT.

ing transit. This spout is easily applied and at once transforms the gallon receptacle into a practical oil can with which almost any aperture can be reached. The Harris five-gallon can is similarly decor-



HARRIS FIVE-GALLON SPOUT CANS.

ated and equipped, the extension spout permitting the can to be tipped so that the oil may easily be poured into any other receptacle. Two five-gallon cans are packed in a wooden case.

**Auto Limerick Competition.**—Limerick experts have an opportunity of adding to their car equipment by means of a competition announced by the Allen Auto Specialty Company, of 1931 Broadway, New York City. All the prizes in

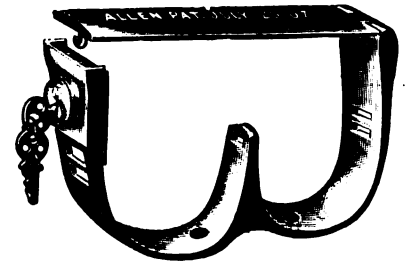

SECOND PRIZE IN LIMERICK CONTEST.

the contest are taken from the Allen company's lines of specialties and include such useful articles as tire holders, tire lock, tire and lamp covers, etc., varying in value from \$10 to \$3.50. Duplicates of the prizes can be seen at the selling branches of the company in New York, Philadelphia, Boston and Chicago.

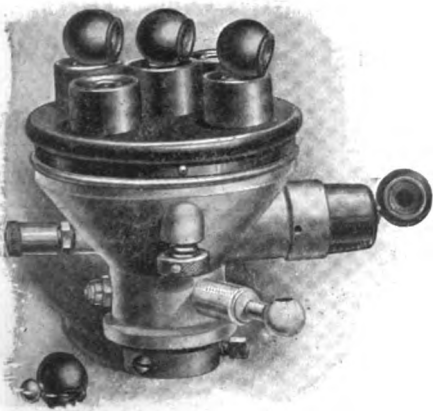

VIEW OF HERZ DISTRIBUTER.

a revolving hardened steel cam plate. The secondary current enters the center of the removable cover and is distributed by a metal segment to the four or six plugs. An extra quality hard rubber cover is employed, and is kept in place by the Herz patented spring nuts.



**INDEX  
TO ADVERTISERS**

Acetylene Gas Illuminating Co. 56	Continental Motor Mfg. Co. 55	Jackson Automobile Co. 54	Picrome Hide Co. 50
Acme Motor Car Co. 54	Corbin Motor Vehicle Corp. 70	Jamesville Mfg. Co. 47	Pierce Engine Co. 55
Adams Co. 54	Corcoran Lamp Co. 52	Jeffery & Co., Thos. B. 157	Pioneer Brass Works 50
Add-Wear Auto Tire Sleeve Co 55	Cornish-Friedburg Motor Car. 54	Jenckel Motor Mfg. Co. 69	Pirelli & Co. 81
Aero & Marine Motor Co. 66	Correspondence School of Motor Car Practice 58	Jenkins Specialty Mfg. Co. 76	Portland Garage Co. 45
Aerocar Motor Co. 54	Cotta, Chas. 56	Johnson Sporting Goods Co. 132	Post & Lester Co. 87 to 123
Ajax-Grueb Rubber Co. 55	Cowles & Co., C. 48	Jones Speedometer 53	Prest-O-Lite Co. 60
Allen Auto Specialty Co. 58	Crane Puller Co. 76	Jones, W. H. 74	Progressive Mfg. Co. 67
Almy Water Tube Boiler Co. 46	Crown Battery Co. 69	K. W. Ignition Co. 67	Quinby Co., J. M. 68
Am. Brass & Alum. Works. 50	Crown Soap Co. 68	Koontz Co., J. H. 67	Raimes & Co. 60
American Distributing Co. 69	Cullman Wheel Co. 59	Kokomo Electric Co. 70	Rainier Co. 55
American Locomotive Motor Car Co. Cover	Day & Co., L. J. 51	Kimball Tire Case Co. 64	Rauch & Lang Carriage Co. 136
Amer. Motor Car Sales Co. 149	De Luxe Motor Car Co. 54	King Top Mfg. Co. 63	Reeves Pulley Co. 50
Anderson Forge & Machine Co. 50	Detroit Steering Wheel Co. 75	Kissell Motor Car Co. 50	Remington Tool & Machine Co. 74
Angier Co. 144-145	Diamond Chain & Mfg. Co. 50	Konigsloew, Otto 50	Remy Electric Co. 53
Apperson Bros. Automobile Co. 134	Diamond Rubber Co. 138	Knox Automobile Co. 143	Republic Rubber Co. 133
Ashtabula Bow Socket Co. 48	Diftz Co., R. E. 69	Lansing-Mahon Press 68	Richardson Engineering Co. 55
Atlas Motor Car Co. 81	Dixon Crucible Co., Joseph 62	Lavalette & Co. 54	Robert Instrument Co. 48
Atwood Mfg. Co. Cover	Dorris Motor Co. 70	Lear Automobile Co., Oscar 55	Robinson & Sons Co., Wm. C. 51
Auburn Automobile Co. 54	Dover Co., Geo. W. 45	Leather Tire Goods Co. 48	Rock Island Tool Co. 67
Audel & Co., Theo. 52	Dow Portable Electric Co. 147	Limousine Carriage Mfg. Co. 56	Ross Gear & Tool Co. 50
Aurora Motor Works. 52	Earl Motor Car Co. 61	Lipman Mfg. Co. 60	Rubay, Leon 68
Austin Automobile Co. 52	Echo Horn Co. 74	Lobe Pump Co. 62	Royal Equipment Co. 47-141
Auto Pump Co. 59	Eclipse Machine Co. 46	Locke & Co. 69	Rushmore Dynamo Works 140
Auto & Supply Co. 59	Edgar Mfg. Co. 46	Lockwood Bros. 54	Salisbury Wheel & Mfg. Co. 48
Autocar Co. 129	Edmunds & Jones Mfg. Co. 77	Locomobile Co. 54	Samson Leather Tire Co. 54
Automobile Supply Co. 46	Eldredge Electric Mfg. Co. 48	Logan Construction Co. 54	Sanford Mfg. Co., F. C. 50
Automobile Trade Directory 65	Ellsworth, J. M. 152	London Auto Supply Co. 48	Saxton Lamp Co. 48
Automobile Utilities Co. 46	Elmore Mfg. Co. 149	Long Mfg. Co. 68	Schacht Mfg. Co. 138
Auto-Shine Co. 60	Empire Automobile Tire Co. 56	Manhattan Screw & Stamping Co. 70	Seaboard Florida Limited 139
Auto Supply Co. 84-85	Empire Wheel Works. 59	Manhattan Storage Co. 56	Selden Motor Vehicle Co. 133
Auxiliary Spring & Vent-Button Co. 48	Excelisor Supply Co. 55	Maple City Mfg. Co. 64	Shawver Co. 59
Avery Portable Lighting Co. 69	Fairmount Eng. Works. 54	Mason, John A. 48	Smith Co., A. O. 59
Babcock Electric Carriage Co. 136	Firestone Tire & Rubber Co. 55	Masury & Son, John W. 71	Smith Mfg. Co., R. H. Cover
Baker Motor Vehicle Co. 54	Fisk Rubber Co. 137	Mathewson Motor Car Co. 139	Spacke Machine Co., F. W. 65
Baldwin Chain & Mfg. Co. 50	Forest City Motor Car Co. 129	Mayo Radiator Co. 59	Spare Motor Wheel of Am. 71
Barnrd-Johnson Auto Supply Co. 48	Franklin Mfg. Co., H. H. 159	McCord & Co. 62	Speed Changing Pulley Co. 64
Barnett Drop Forging Co. 66	Fry, T. C. & W. L. 46	Merchant & Evans Co. 67	Spicer Universal Joint Mfg. Co. 50
Beaver Mfg. Co. 56	G & J Tire Co. 134	Merritt & Co. 46	Spittdorf, C. F. 54
Behen-Faught Motor Car Equipment Co. 47	Garford Motor Car Co. 54	Metzger, C. A. 74	Sprague Umbrella Co. 132
Beloit Supply Co. 71	Gearless Transmission Co. 36	Meyers & Sons, C. G. 48	Springfield Metal Body Co. 48
Bemus, T. Alton 64	Geiszler Bros. 58	Michelin Tire Co. 80	Springfield Portable Construction Co. 135
Bernz, Otto 46	Gemmer Mfg. Co. 68	Miller Mfg. Co. 50	Standard Automatic Lub. Co. 47
Blasler Mfg. Co., M. E. 48	General Accumulator & Battery Co. 47	Miller, Chas. E. 59	Standard Oil Co. 72
Bliss-Chester Co. 48	Gibney & Bros., Jas. L. 47	Mitchell Motor Car Co. 54	Standard Welding Co. 76
Blomstrom Mfg. Co. 66	Gilbert Mfg. Co. 59	Model Automobile Co. 136	Stanley, John T. 137
Boker & Co., H. 50	Goldberg Motor Car Device Mfg. Co. 63	Moline Automobile Co. 136	Steam Carriage Boiler Co. 59
Borbein Auto Co. 47	Gordon Automobile Supply Co. 76	Montgomery-Washburn Co. 76	Stearns Co., F. B. 55
Bosch, Robert 130	Graves & Congdon Co. 67	Moon Motor Car Co. 54	Stevens-Duryea Co. 130
Boston Auto Gage Co. 58	Gray-Hawley Mfg. Co. 67	Morgan & Wright 137	Stitch-in-Time Vulcanizer Co. 63
Bowers Co., F. E. 59	Grout Bros. Auto Co. 151	Morrison-Ricker Mfg. Co. 79	Streator Motor Car Co. 146
Bowser & Co., S. F. 58	Half-Nelson Tire Co. 82	Mosler & Co., A. R. 49	Streit Machine Co. 58
Boyle & Co., John 148	Ham Mfg. Co., C. T. 142	Moss Photo Engraving Co. 154	Studebaker Automobile Co. 155
Bridgeport Vehicle Co. 48	Hans, Edmund E. 71	Motor Car Equip. Co. 52	Success Auto Buggy Co. 55
Brown, Wm. W. 46	Hardy Co., The R. E. 60	Motz Clincher Tire & Rub. Co. 55	Supplementary Spiral Spring 80
Brownell Motor Co., F. A. 56	Harris, Chas. J. 68	Mueller, Albert 58	Sweet, Chas. F. 77
Brush Runabout Co. 135	Harris Oil Co., A. W. 47	Mutty Co., L. J. 57	Swinehart Clincher Tire Co. 66
Buckeye Jack Mfg. Co. 73	Hartford Rubber Works Co. 53	Myers Auto Top Co. 48	Syracuse Aluminum & Bronze Co. 50
Buckeye Mfg. Co. 54	Hartford Suspension Co. 59	National Auto Accessories Co. 47	Syracuse Plating Works. 48
Buffalo Carbureter Co. 150	Hatcher Auto Parts Co. 73	National Brake & Clutch Co. 140	Thomas Motor Co., E. R. 32
Bullard Automatic Wrench Co. 76	Hatfield Motor Vehicle Co. 54	National Motor Vehicle Co. 143	Thompson Sons Co., J. P. 47
Bullard Specialty Co. 141	Haynes Automobile Co. 75	Neustadt Auto & Supply Co. 74	Tray Plate Battery Co. 67
Buob & Scheu. 48	Healy Leather Tire Co. 55	Never-Miss Spark Plug Co. 47	Trebert Gas Engine Co. 55
Cadillac Motor Car Co. 131	Heinze Electric Co. 133	New Process Rawhide Co. 66	Tucker, C. F. 46
Cameron Car Co. 66	Hercules Auto Specialty Co. 72	Nordyke & Marmon Co. 54	Torbenesen Motor Car Co. 73
Canton Drop Forge & Mfg. Co. 50	Hess-Bright Co. 50	Northern Motor Car Co. 142	Turner Brass Works. 50
Capitol Auto Co. 48	Hicks Speed Indicator Co. 68	Northway Motor & Mfg. Co. 62	Two-Spot Mfg. Co. 77
Case & Hechinger. 69	Hoffecker Co. 46	Nuttall Co., R. D. 50	Uncas Specialty Co. 64
Champion Co., A. 77	Hoffman, Geo. W. 46	N. Y. Sporting Goods Co. 58	Walker Mfg. Co., E. C. 51
Chase & Co., L. C. 62	Holley Bros. Co. 80	N. Y. & N. J. Lubricant Co. 75	Warner Instrument Co. 139
Chelsea Clock Co. Cover	Holsman Automobile Co. 52	Ofeldt & Sons. 46	Warner Pole & Top Co. 48
Clark, E. S. 46	Hopewell Bros. 62	Olds Motor Car Co. 54	Watt-Detroit Carbureter Co. 73
Cleanola Co. 64	Hotel Gilsey House. 65	Pacific Tucking & Mfg. Co. 46	Waukesha Motor Co. 65
Coates Clipper Mfg. Co. 51	Hotel Pierrepont. 65	Packard Electric Co. 47	Wayne Automobile Co. 160
Coes Wrench Co. 42	Hotel Piney Woods Inn. 65	Packard Motor Car Co. 156	Weed Chain Tire Grip Co. 56
Comptoir d'Innovations pour Automobiles 60	Hotel Richmond. 65	Palmer & Singer Mfg. Co. 55	Welch Motor Car Co. 70
Conn. Steel & Wire Co. 48	Hotel Tuller. 65	Parish & Bingham. 50	Western Motor Co. 68
Conn. Tel. & Elec. Co. 72	Howard Motor Works. 54	Parker, Stearns & Co. 68	Weston Elec. Instrument Co. 75
Continental Caoutchouc Co. 55	Hoyt Electrical Ins. Co. 131	Pease & Sons, S. C. 48	Wheeler & Schebler. 148
	Hub Lubricator Co. 76	Penn. Auto Motor Co. 54	White Co., The. 153
	Hume Carriage Co. 51	Perfection Grease Co. 68	Whitney Mfg. Co. 76
	Hyatt Roller Bearing Co. 77	Perkins-Campbell Co. 56	Winton Motor Carriage Co. Cover
	Hydraulic Pressed Steel Co. 50	Pettingell-Andrews Co. 78-79	Witherbee Igniter Co. 51
	Imperial Motor Car Co. 146	Peugeot Freres 55	Wyman & Gordon Co. 45
	Indestructible Steel Wheel Co. 60	Pfanstiel Elec. Laboratory. 51	York Motor Car Co. 153

FOR UNMATCHABLE QUALITY BUY

**COES**

STEEL HANDLE MODEL WRENCH

91

91

Look for the name — COES

**THE WRENCH for Automobilists**

High-grade quality in every detail of design, material, workmanship and up-to-date improvement. Excellence with extremely reasonable cost.

- NON-BREAKABLE CASTINGS
- NON-STRIPABLE THREADS
- NON-TRoublesome PARTS

**QUALITY**

Through and Through.



70 years splendid reputation worthily maintained right up to the present time as the World's Best Wrench Makers. Write for "Wrench Book" free.

**COES WRENCH CO., WORCESTER, MASS.**

# THE AUTOMOBILE

## New England's Big Show

BOSTON, March 11.— Remarkable expansion has been the characteristic key note of the annual exhibitions of the Boston Automobile Dealers' Association, and the Sixth Annual Show, which opened in Mechanics Building on Saturday evening with an attendance of over 30,000 people, is the most comprehensive exhibit of automobiles,

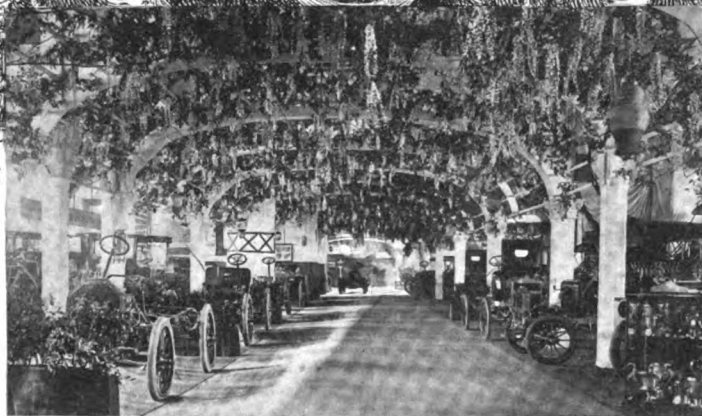

judging from the sales reported during the opening days of the show, the Boston public had not been supplied, to say nothing of the New England back counties which had still to be heard from.

Not only has the Boston show been an exception to the general run this season in that it has been a success from the point of view of the exhibitors

automobile-making material and accessories that has ever congregated under one roof in the New England States. Hitherto much of the available space has been taken up with exhibits of motor boats, so much so that it has been necessary to secure extra space in Horticultural Hall in addition to Mechanics Building. The advantage of an exclusive automobile and accessories exhibit is at once apparent to the visitor in the tasteful arrangement of the cars and the ample space allowed for a comprehensive inspection of the wares displayed. The motor boat element has, however, not been entirely eliminated, as in the basement two or three models are shown. But the basement is primarily devoted to the commercial car, the display of which is in keeping with the rapid progress which is being made in the development of this important branch of the industry. Poor lighting here, however, detracts from the effectiveness of the exhibits.

who gauge show success by the number of orders taken and the prospects listed, but it has been a success from the mechanical standpoint, for it is the most complete show that has been held. No discriminating line whatever is drawn in Boston between any factions of manufacturers; they all bunk together in harmony, and this accounts in no small measure for the completeness of the exhibit. But of more importance, perhaps, is the fact that now the majority of the manufacturers have their complete line ready for 1908. When the New York shows were held in October and November, and even at the time of the Chicago show in December not all the manufacturers by any means had their cars ready for exhibition and they had to rush through show material. Since those shows, however, the factories have been at work producing the regular line of cars for the riding season, and they are shown complete for the first time at this exhibition.

### Business Brisk from the Start.

When it was officially announced that 32,000 people had visited the show on the opening night, and that even in the midst of that tremendous crowd which practically filled every available inch of space in the huge building, sales of cars had been made, the statement seemed almost a miracle. In fact, it seems as if the public had been waiting for the opening of the show before doing business. All through the winter cars have been sold in Boston, probably in greater numbers than in most of the other large places, and there are not a few leading dealers who can show a better business through November, December, January and February than last year, but

Not a few of the manufacturers who have traveled the show circuit are loud in their praise of what Boston has to offer and any doubters of the value of a late show in New England for retail purposes have been completely won over.

### General Effectiveness of Decorations.

As usual, the Boston dealers have scored another success with the decorations and general set up of the exhibits. The Japanese garden scene promised by Manager Chester I. Campbell comes up to the vivid advance descriptions, which is saying a good deal. While the temple gate effect in Grand Hall is not quite as picturesque as were the apple trees of last year, it has the advantage of giving a more roomy appearance to



Where the Show Holds Forth.

the hall. In Exhibition Hall, where the aisles are all covered by wistaria arbors, the effect is exceedingly picturesque and the prestige of Grand Hall as the best part of the show is in danger. Exhibitors who have had much experience in other places are considerably surprised at the generosity of the Boston show management, which supplies along with the space and for the price thereof, not only the decorations, carpeting and the like, but the signs, the furniture and free telephones connecting with all parts of the building and with all sections of the metropolitan district.

There is a great variety at this show, greater, perhaps, than at any previous exhibition of the year, for there are included under the same roof domestic and foreign machines, licensed and unlicensed, gasoline, steam and electric, pleasure and commercial vehicles, and almost every different variety of design of body or chassis. Such prominent foreign cars as the Fiat and Renault, such leading Selden licenses as the Packard, Pierce, Peerless, Locomobile, Lozier and Royal; well-known independents like the Ford, Rambler, Rainier, Maxwell and Reo; gasoline car makers of both divisions, the White, Lane, Clark, Stanley and others of the steamers, the Baker, Bailey and Studebaker in the electrics, pleasure car makers too numerous to mention, the Rapid, Studebaker and other manufacturers of commercial vehicles are all in the Boston show.

At this show Boston has made the acquaintance for the first time with the high-wheeled motor carriage, and they appear to be good in wind and limb, and well adapted for some of the roads up north. As many as a half-dozen different makes of buggies are on exhibition, and agencies have

been placed for two or more in Boston. It is noticeable that the horseless buggy idea is taken to rather partially by the show visitors from the rural parts.

Another novelty for the Boston show is a complete tire exhibit. Last year the leading tire manufacturers did not exhibit in Boston, but this year they are here in force, and are trying to make up for the loss which they suffered from not taking space a year ago. It has reached a time when the retail purchaser is about as much interested in tires as he is in the automobiles themselves, and the tire exhibits are noticeably popular. The other accessories exhibits are complete, and occupy the whole of the large galleries of the two main halls of the building.

The idea of using the basement for the exhibition of pleasure carriages has not taken very well, and though there are a number of cars in the basement, the agents for which could not secure space on the main floor, it has been found difficult to get the crowd below stairs that accumulates around the exhibits above. There are several good exhibits of commercial wagons in the basement and some instructive exhibits of parts and of machinery.

One specially interesting division of the basement department is the model repair shop. Plans for this were secured by a competition conducted by the management. The shop occupies the space under the stage, and in it is some up-to-date machinery adapted for the work.

It is too early to make any prediction about what the Boston show will accomplish in the way of business, but, if the first few days may be taken as a criterion, the exhibitors are laying out a large amount of work for the remainder of the season.



## SOME NEW THINGS UNCOVERED AT THE HUB'S SHOW

**B**OSTON, March 12.—Boston's show has always been noted for the number of new things that make their debut at this closing event of the show season. New England has been the home of the manufacture of small metal wares for more than a century past, so that it is hardly to be wondered at that many of the novelties in the shape of accessories first see the light "Down East."

**Only New Car in Show, Auto Buggy.**—A New England recruit to the buggy type of automobile has been presented within the last few days by the Crown Motor Vehicle Com-

pany, with factories at Boston and Amesbury, Mass. The power plant of this popular type of automobile is a double opposed air-cooled motor with a bore of 4 3/8 inches and stroke of four inches, rated at 12-horsepower. Current is supplied by special storage batteries, and ignition is by jump spark. Lubrication is through a force feed sight oiler. The engine has three-point suspension and is controlled by spark and throttle levers in convenient position.

On account of its ability to withstand rough usage, an individual multiple disc clutch has been selected as the first



unit in the transmission of power from the engine to the road wheels. There are two forward and two reverse speeds, through sliding gear, and spur gear type of differential. All bearings are of Parsons white bronze and of ample size. Brakes are of the double expanding type on the rear road wheel drums.

To ensure easy riding over rough roads, full elliptic springs are fitted front and rear, and carry an angle steel or laminated wood frame and special "Crown" body. The 40 by 1 1-8-inch Sarven patent wheels are equipped with solid rubber tires. Maximum speed is declared to be 30 miles an hour.

**Automatic Meshing Gear-set.**—Among the exhibits that attract the mechanical sharps is one that causes the man on the lookout for new things to stop and look it over. It is an automatically meshing gear-set, of which H. O. Fletcher, of Hyde Park, Mass., is the inventor. The model shown only



Where the Thomas Was Shown Under the Wistaria.

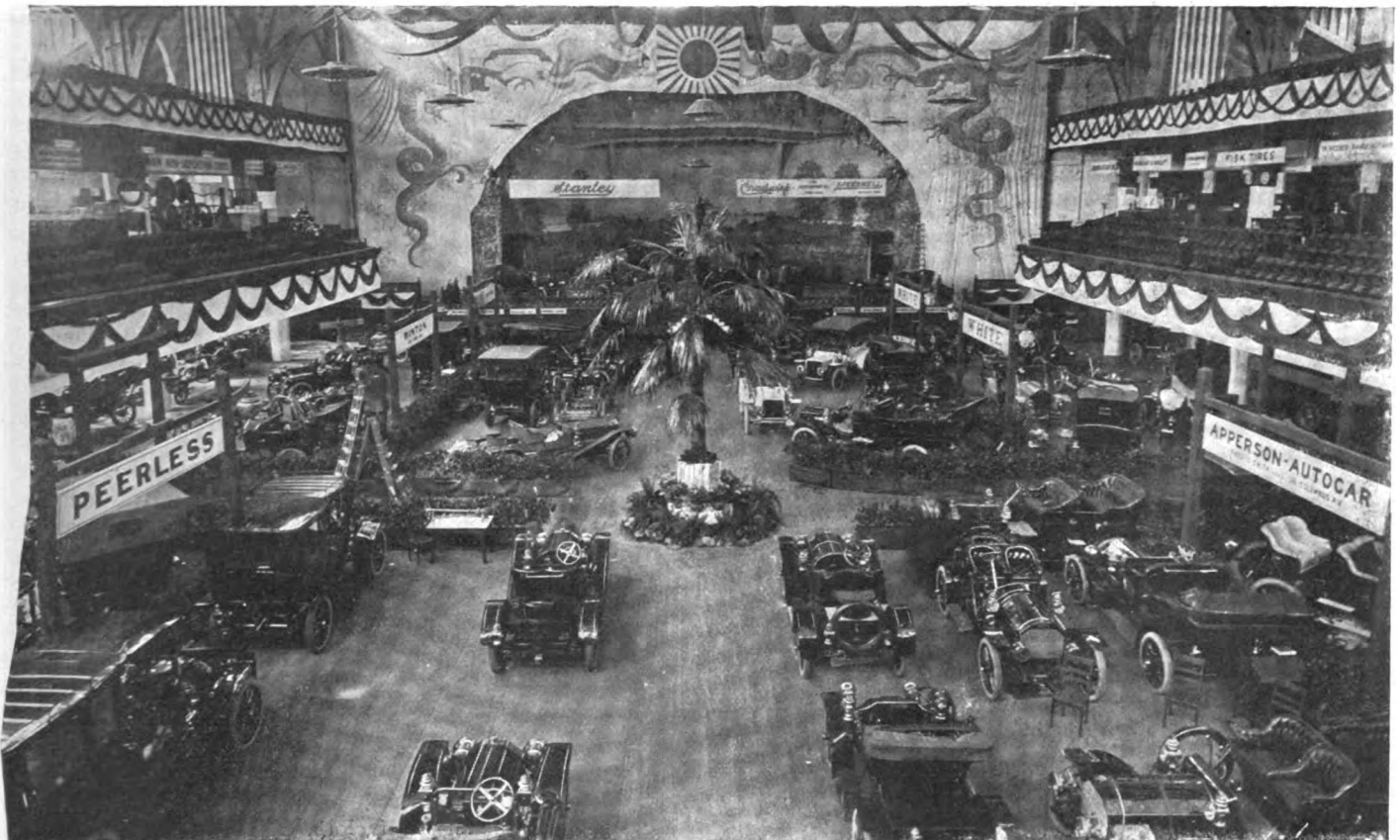

Looking Down from the Gallery, Where the Band Played, at the Exhibits on the Main Floor of the Big Auditorium.



Oldsmobiles Were Well Placed Near Main Entrance.

provides two speeds forward, but suffices to show the principle of the device, which consists of a double-faced jaw clutch, placed between a right and left-hand worm and corresponding to similar clutches on the speed pinions of the main shaft of the set. The sliding pinions are shifted in the usual manner, but it is impossible for the car to go ahead on a certain speed until the pinions representing it are fully in mesh, as the pinion engaged runs loosely on its shaft, but as soon as the revolving gear picks it up it moves toward the jaw clutch on a long-pitch worm until it engages and then becomes solid with the shaft. For the other speed, the worm is cut in the opposite direction. When disengaging the pinions are automatically moved away from the clutch.

**A New Shock Absorber Represented.**—"Cars are invariably suspended by 'leaf-springs' because the leaf-spring principle has proved to be the only principle having the strength to carry the weight, combined with the resiliency to absorb



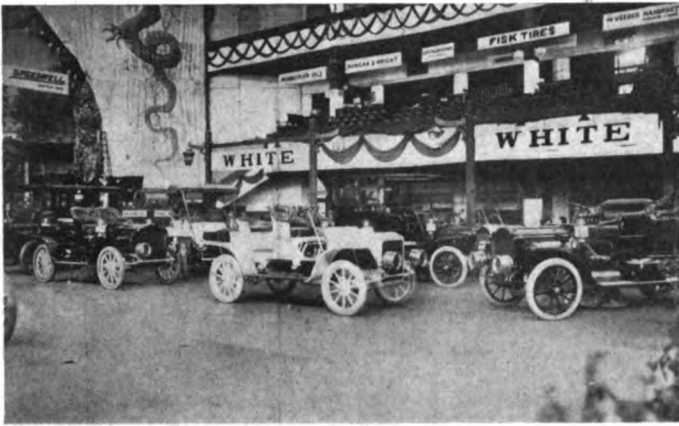

The White Steamer Line Was Imposing and Complete.

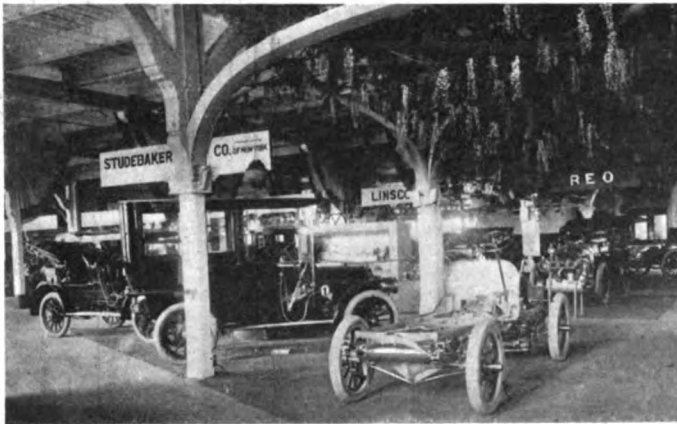

Studebakers, Reos and Premiers Were Neighbors.

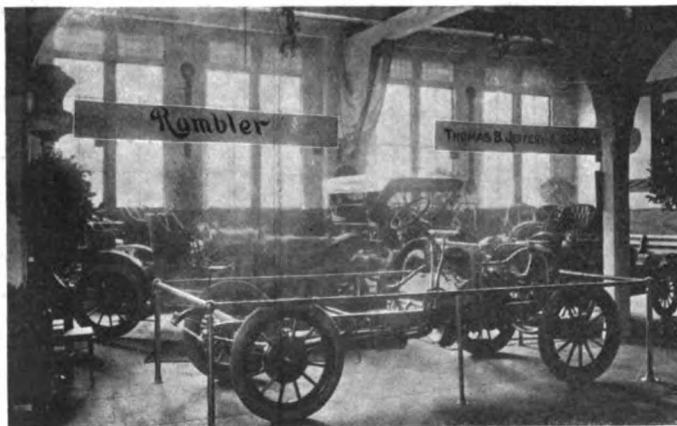

A Warm, Spring Sun Lighted Up the Rambler Display.

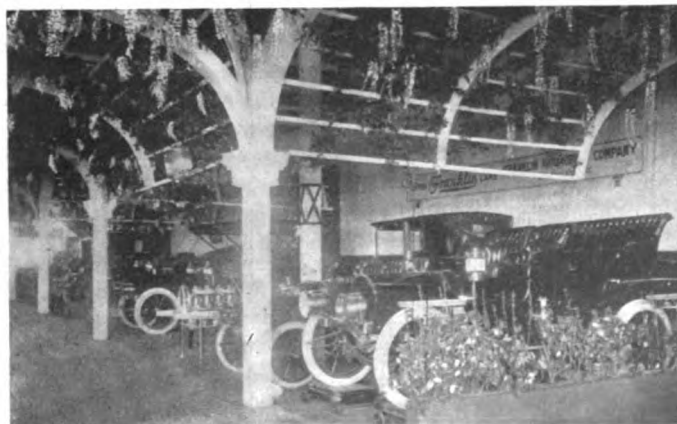

The Air-cooled Franklins Had an Artistic Setting.

shocks," says the maker of the new Du-Ro shock absorber, of which Duncan Robinson, 89 State street, Boston, Mass., is the inventor and manufacturer. It consists of a stationary hub, rigidly attached to the car frame, and surrounded by a revoluble ring. A steel chain attached to one end of the ring, and partially encircling it, is attached at its other end to the axle or running gear of the car. Thus any movement of the car frame pulls on the chain and turns the ring, the movement of the latter being resisted by a set of powerful leaf springs. A shock turns the ring against the progressive resistance of the springs until the force of the shock is equalized by the power of the resistance, thus quietly absorbing the disturbance. This progressive resistance begins at nothing and increases as needed by calling into play more and more leaves, and as the strength of the latter has been designed to be greatly in excess of any possible demand, there is a proper amount of resistance to counterbalance every shock, whether small or great.

**Sterling Alternating Ignition Device.**—When a direct current passes through the platinum contacts of a vibrator coil continuously in one direction, the same action takes place as is noticed in the carbons of an ordinary arc light, the positive being disintegrated and the resultant material being transferred to the negative, causing a point to form on the latter and a crater on the former, and when the points get in this condition they are said to be pitted. They then no longer give good service. The Sterling alternating ignition device has been brought out to overcome this, and, according to its makers, the Sterling Alternating Ignition Company, Binghamton, N. Y., its use permits of enjoying all the advantages of the battery type of high-tension ignition, without any of its drawbacks. For a four-cylinder engine, a standard timer with four stationary contacts is employed in connection with four simple coils having neither vibrators nor condensers. Included in these connections are four normally closed switches—one at each coil, there being a common condenser for all the coils. It is connected across the single vibrator employed and the alternating current through the latter leaves the contacts smooth and clean. Only one adjustment is necessary on the system, while it is possible to stow the coils anywhere on the car. Individual button switches are provided for testing purposes. The same concern is showing the Sterling double contact timer, which is of the roller type, but departs from the usual practice by employing two rollers set opposite each other, thus balancing the strain on the shaft and reducing wear to a minimum. To supply the demand for a cheaper timer, the same firm shows the "M. I. P.," which is also of the roller type.

**Bullet-proof Cloth Among Novelties.**—It may appear at first sight that bullet-proof cloth, while not a novelty frequently seen at automobile shows, would be rather out of place at any function of the kind. But a little consideration makes it plain that a cloth which will stop a bullet will also stop the obnoxious horseshoe nail, the piece of jagged glass and the thousand and one other things that find their way into the pneumatic tires in the course of service. The cloth is the invention of Casimir Zeglen, and is manufactured by the Zeglen Bullet-proof Cloth Company, South Bend, Ind. It is made of raw silk woven in a special manner, and is made in various thicknesses, the entire substance being merely a textile fabric. This material has been applied to the lining of an automobile outer shoe in the same manner in which the ordinary canvas fabric is employed. The most severe tests failed to puncture the tires, the attack being made in one case by means of two boards placed about 60 feet apart and filled with long French brads, one-third of which were bent to point toward the approaching tire, one-third standing upright, and the remainder leaning away. Half a dozen broken bottles were also strewn on the road and

(Continued on page 375)



Though the Racing Was Decidedly Meager, the Onlookers Were More Numerous Than Ever Before.

## FLORIDA'S MEET SUPPLIED MORE RECORDS THAN RACES

By JOHN C. WETMORE.

ORMOND, FLA., March 7.—Thanks to the gallant doings of the little guard of skirmishers that the Automobile Club of America had succeeded in gathering to preserve the continuity of the racing tournaments on Florida's far-famed sands, the sixth annual Ormond-Daytona meet in the wind-up was not only saved from utter failure, but there was even revived some of the glories of the past through several noteworthy and successful assaults on Father Time.

During the concluding two days of the meet, the fickle goddess of fortune came to Florida's rescue with favoring winds and a fast beach, and a healing touch to the infirmities that earlier in the week had crippled several of the beach invaders. As a result of their four days of campaigning, the coterie of contenders carried away with them quite a full bag of new records for the season's advertising.

A notable achievement of the meet was Emanuel Cedrino's 300-mile run on Thursday with the 60-horsepower Fiat Cyclone, shod with Continentals. In this race the Italian-American covered the three centuries in 3 h. 53 min. 44 sec., an average of 77.02 miles an hour, as against the record average of 70.8 miles, scored by Nazzaro in the last Grand Prix run. Incidentally, en route, Cedrino put up 3 h. 16 min.

48 2-5 sec. as a new figure for 250 miles, gaining this added honor. The one long-distance record for the beach—that for the previous maximum of Florida racing, 100-miles in 1 h. 15 min. 40 2-5 sec., scored by Clifford Earp and a Napier in 1906—was supplanted by 1 h. 12 min. 56 1-5 sec., thanks to Maurice Bernin and his speedy 60-horsepower Renault, wearing Michelines, a performance whose merit may be judged by the average of 82.26 miles per hour it showed.

Records for the beach were established for 125 and 150 miles by Louis J. Bergdoll, of Philadelphia, with his 60-horsepower Benz stock car, Continental tired. On Tuesday, the opening day, in the 150-mile stock car race, he scored 2 h. 10 min. 38 sec. for the 125 miles and 2 h. 50 min. 33 sec. for the 150 miles. The following day, in the invitation race for amateur drivers, he cut the 125-mile figures to 1 h. 52 min. 30 2-5 sec., an average of 66.36 miles per hour.

The members of the Automobile Club of America contest committee, which conducted the races, expressed themselves as satisfied with the outcome of the meet, and not at all regretful at having put it through with the limited field of entries. The paucity of the contenders was attributed to unfavorable trade and financial conditions; the



Official Stand, Where the Notables of Automobiling Gathered.

Among those to be seen in the picture, starting from the left, are Committeeman A. H. Whiting, A. C. A.; Vice-president George E. Sebring, of the F. E. C. A. A.; Harlan W. Whipple, ex-president of the A. A. A.; Major J. B. Foote (in the foreground), president of the F. E. C. A. A.; S. B. Stevens, of Rome, N. Y.; Referee Robert Lee Morrell (at telephone); Committeeman A. L. Riker, and Timer S. M. Butler.

promotion of another meet next year is favored in club and trade circles.

Among the racing fans in attendance, the opinion was unanimous that the substitution of long for short-distance racing on the beach was a wise innovation. That interest in the Florida races is unabated with the general public was proved by the Ormond Hotel being crowded, despite a poor season and no perceptible diminution in the crowds on the beach, at least early in the week, being noticeable. How great an influence on the hotel business this racing has had may be judged from the fact that the first year of the tournament, in 1903, the January house count at Ormond was 1,200; that it rose to 3,000 in 1904, and to 5,000 in 1905, the banner year, and that the present little meet enabled the hotel to beat the record of a previous year's successful corresponding week.



Mr. and Mrs. Paul Lacroix and Cedrino

**What Happened the Opening Day.**

The racing began on Tuesday with the annual 100-mile run for the Minneapolis cup. The course was a 12 1-2-mile stretch, at Daytona, furnishing a 25-mile circuit with eight turns in all. Three cars faced Starter Wagner: Harry Levey's 120-horsepower Hotchkiss, which Elliot F. Shepard drove in the last Vanderbilt Cup race, piloted by Harry B. Shefts; E. Rand Hollander's 60-horsepower Fiat Cyclone, a middle-weight racer equipped with the engine of last year's German Emperor car, driven by Emanuel Cedrino, and W. Gould Brokaw's 120-horsepower front-drive Christie, which Walter Christie built and raced in last year's French Grand Prix, and which later captured a mile record of 35 seconds on Atlantic City's beach, with E. B. Blakely at the wheel.

The Hotchkiss was first away, but stopped in a furlong with a slipping clutch, the Fiat taking the lead and reaching the turn at the Inlet in 5:58. Then its troubles began with losing one of its light front wheel racing tires, which came off and had to be replaced, only to be lost again. Cedrino reached the clubhouse (20 miles) in 15:25, running on a bare rim, just as Earp had done two years before in the same race. A second tire was put on, only to be again lost. From this point Cedrino continued on three tires and a rim. In the mean time the luckless Christie "Big Bear" had broken a valve and been put out of the race, and the Hotchkiss had mended its clutch after a long delay and again taken up the running. The score by laps tells the story of the race.

Driver.	Car.	25 miles.	50 miles.	75 miles.	100 miles.
Cedrino	(Flat)	26:39	4-5	64:05	85:05
Shefts	(Hotchkiss)	42:37	77:51		110:20

The Hotchkiss completed 75 miles, but was not timed after being scored at 50 miles. Cedrino had lost 30 minutes in all in replacing tires. Incidentally, Cedrino won the \$100 prize offered by Joseph M. Gilbert for a victory on Continental tires and demountable rims.

Four cars were at once started in the 150 stock car race: Louis J. Bergdoll, 60-horsepower Benz; James Laughlin, 3rd, 40-horsepower Cleveland; J. Carey, 70-horsepower Thomas; and E. W. Howard, in W. Gould Brokaw's 40-horsepower Allen-Kingston. The contest quickly became a runaway for Bergdoll, with Laughlin a hopeless pursuer for 100 miles, the Allen-Kingston being towed back from

the inlet with a melted bearing, and the Thomas quitting when it lost a tire.

The Benz cantered over the course an easy winner, completing the laps as follows: 25 miles, 25:15; 50 miles, 61:02; 75 miles, 85:32; 100 miles, 107:31; 125 miles, 130:38; 150 miles, 2 h. 40 min. 50 sec., establishing records for the last two distances. The Cleveland's score was: 25 miles, 46:32; 50 miles, 77:24; 75 miles, 109:37; 100 miles, 2 h. 26 min. 46 sec. The Thomas got as far as the 25-mile post in 43:06.

**The Amateur Race on Wednesday.**

The condition of the beach on Wednesday, though somewhat improved, was such that the committee decided to stick to the 12 1-2-mile Daytona stretch for the running of the 125-mile amateur invitation race. S. B. Stevens, a veteran Ormond Beach pilot, was at the wheel of the Fiat Cyclone; W. Gould Brokaw's "Little Christie" of 60 horsepower was entrusted to R. G. Kelsey, and Louis J. Bergdoll was again on hand with his Benz "60."

Again there was a tale to tell of shattered hopes, and one of these races that are not always to the swift; for, after running with a safe lead for 50 miles, Stevens pulled up limping at the clubhouse (70 miles in 58:18) with a broken rocker arm. The missing part was not at hand, and 29:05 was lost in getting a replacement from the garage at Ormond. With such a handicap, so speedy a car as the Benz was not to be caught. Its owner, Mr. Bergdoll, and the car were in fine form, and won easily, cutting off a big slice of the previous day's 125-mile record figures, with the following score:

Driver.	Car.	25 miles.	50 miles.	75 miles.	100 miles.	125 miles.
Bergdoll	Benz	22:54	46:41	67:49	90:25	113:30 2-5
Stevens	Flat	20:40	41:37	70:05		
Kelsey	Christie	37:07	65:46			

Stevens made a game but hopeless chase of it, reaching the 95-mile post in 1:54:28, when he stopped.



Referee Morrell Overseeing a Start Involving the Flat, Christie, and Hotchkiss.

**A 300-mile World's Record.**

With the third day's racing on Thursday came the redemption of the meet at last through an excellent contest in which three of the four contenders survived to the finish. The world's average speed for an international cup distance was broken, and the famous stretch of Florida beach sand took on once more the unrivaled racing shape that has given it fame as the fastest motor car race course on earth. In this, the chief event of the tournament, the 256-mile run for the Club cup, for the first time during the tournament those worthy Italian and French rivals met; Bernin having at last repaired the damage done the engine of Paul Lacroix's new 60-horsepower Renault racer through the breaking of an oil-feed in preliminary practice. Cedrino, as a matter of course, was at the wheel of the Fiat Cyclone. On behalf of the United States, two Christies essayed to go against the foreigners: the 120-horsepower "Big Bear," piloted by E. B. Blakely, and the "Little Christie" 60, driven by R. G. Kelsey. The race was run over the entire beach course of 16 miles, in eight circuits of 32 miles each. The race was originally scheduled for 288 miles, but through fear that the incoming tide might rise too high before that point was reached, it was agreed before the start to reduce the distance to 256 miles.



**Cedrino and the Continental-tired Cyclone.**

As may be imagined, there was eager rubbernecking for the one that should first be sighted returning from the Inlet. It proved to be Bernin, who completed the 20 miles in 15:59, followed by Kelsey in 18:58 and Cedrino in 19:36. The Fiat had stopped five minutes to replace an igniter. The first lap was completed with Bernin still in the lead, pursued by Cedrino, who had passed Kelsey.

In the next lap, tire troubles befell the Renault, which was the beginning of its final undoing. Thrice did Bernin have to stop, twice to put on a new rim and once to make a complete change of shoe and tube.

The 100-mile post was reached by Cedrino in 81:39 3-5; by Bernin in 97:33 3-5, and by Kelsey in 98:27. All three thus qualified for the sprints on the following day.

For 84 miles the race was fairly close between Cedrino and Bernin, but after that two stops for replacements made the Renault's chase of the Fiat almost hopeless, though the Frenchman persevered to the end.

Cedrino finished in whirlwind style, not having had to stop to change his tires; his time for the 256 miles being 3 h. 21 min. 27 2-5 sec. The final brush for second place between Kelsey and Bernin was exciting, but a quarter of a mile separating them at the tape. The American finished twelve seconds ahead of the Frenchman. The big Christie had sucked a bit of the porcelain plug into the cylinder and was

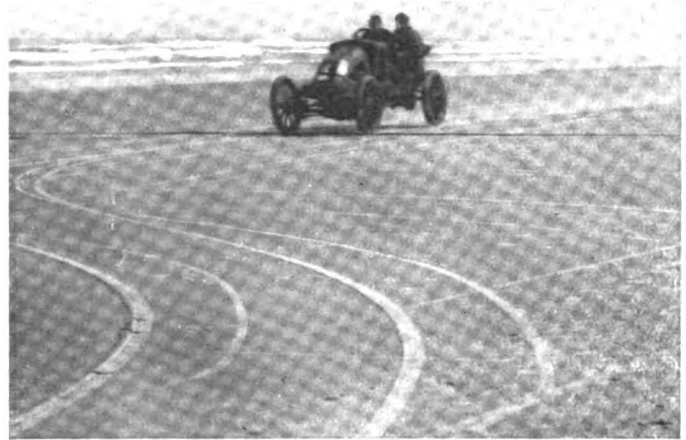

**Bernin and Renault Which Won the 100-mile Match.**

early out of the running, though Blakely struggled on for two circuits before quitting. The score:

Driver.	Car.	32 miles.	128 miles.	256 miles.
Cedrino.....	Fiat .....	29:16	103:11	201:27 4-5
Kelsey.....	Christie .....	31:15	123:55	246:26
Bernin.....	Renault .....	25:37	117:40	246:38

Cedrino covered 250 miles in 3 h. 16 min. 48 3-5 sec. It had been arranged during the progress of the race that the Fiat should continue for new figures up to 300 miles, which distance was made in 3 h. 53 min. 44 sec.

**Century and Sprint Records Go.**

For the get-away day of the meet, Florida's favorite saint had favored the motorists with a fast beach and a stiff wind



**Louis J. Bergdoll and Benz Big Cup Winner.**



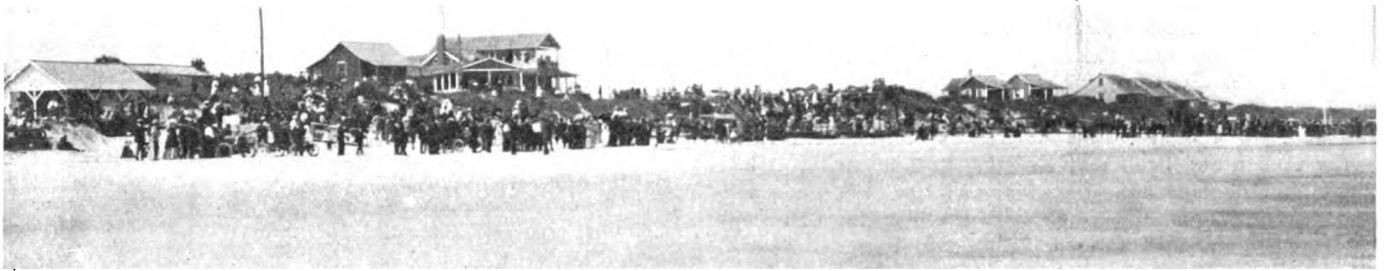

In Front of the Clubhouse at Daytona, Where Thousands Gathered Expectantly and Departed Disappointed.

from the South for the record trials of Friday. Four cars had qualified for the sprints by averages of 60 miles an hour or better for 100 miles or more.

All faced the electrically-operated tape. They were: Bernin, Renault; Cedrino, Fiat; Bergdoll, Benz; and Kelsey, 60-horsepower Christie. After the other contestants had had their fling at Father Time, Cedrino made his run with the Fiat. The result was a record of :35. Though it does not approach, of course, the :28 1-5 made by Marriott with the Stanley steamer, or the :30 3-5 scored by Demogeot on this beach in 1906 with the 200-horsepower Darracq, or the :32 3-5 made by H. L. Bowden with the 120-horsepower overweight Mercedes in 1905, it has only been beaten by one long-distance gasoline car, the 80-horsepower Napier, which Arthur MacDonald drove in :34 2-5 in 1905. Walter Christie tied it with :35 in the *Great Bear* at Atlantic City in 1905. As before stated, however, Cedrino sets up a new middleweight record in place of the :40 3-5 scored by Guy Vaughan in the 80-horsepower Darracq in 1906.

Bernin with the Renault was content with :39 1-5, with long-distance racing equipment. R. G. Kelsey made :42 4-5 twice in succession with the Little Christie, and L. J. Bergdoll scored :45 4-5 and :45 3-5 with the Benz, G. P. Parker driving.

After the racing was all over, David Bruce Brown, a New York schoolboy, who had run away to attend the meet and had made friends with Cedrino, begged to be allowed to try for the amateur record of :39 held by W. K. Vanderbilt, Jr., since 1904 with a 90-horsepower Mercedes. The official consulted, and set up the wire traps for him. The youngster took the wheel of the Fiat Cyclone and captured the amateur record with a mile run in :35 3-5.

Honors were made fairly easy between the rival foreign cracks and tire makers by the outcome of a 100-mile match race between the Renault, driven by Bernin, and the Fiat Cyclone, with S. B. Stevens at the wheel. The wager was \$200 a side. This time Michelin tires did themselves proud and made a strenuous century without being touched. The reliable Renault ran without a skip, won the match hands down, and at the end had gathered to itself a new world's record for the distance of 1:12:56 1-5, supplanting Clifford Earp's 1:15:40 2-5 made with the Napier in the race for the Minneapolis cup in 1906. The score tells the tale in part:

Driver.	Car.	24 miles.	56 miles.	88 miles.	100 miles.
Bernin.....	Renault	17:42	41:02	64:10	72:56 1-5
Stevens.....	Fiat	20:42	44:02	75:02	83:59

The Renault led from start to finish. At four miles Stevens stopped at the stand, thinking there was trouble with his engine, found none, and continued. Further down the beach, however, he lost five minutes in replacing an igniter. The Fiat lost some of its speed of the day before and Cedrino attributed it to the big sprockets put on for the record trials and the feeding of too much gasoline. The attempt to break

the stiff wind with the big sprockets for a long distance slowed him.

Most of the officials of the meet left for the North Friday night, but all of the newspaper men, photographers, and several tradesmen stayed behind for the Savannah meet.

**One of the Disastrous Incidents of the Meet.**

DAYTONA, FLA., March 8.—There was some talk of a damage suit involving James Laughlin, 3d, of Pittsburgh, who loaned his Cleveland car, and R. G. Kelsey, of New York, the man to whom he loaned it. The loan was on Thursday night, and Mr. Kelsey, driving up the beach at high speed, because of the fog, ran into the wreck of the old ship that has rested in the sands for many years. Twenty-four hours later the car was dug out at low tide. The difficulty has been adjusted by Mr. Kelsey agreeing to have Mr. Laughlin's car rebuilt and made as good as new. This car is the Jacksonville-Miami pathfinder.

**Cadillacs Lead at First Jacksonville-Miami Control.**

ORMOND, FLA., March 10.—At 6:45 to-day the first of the contestants in the Jacksonville-Miami run arrived here, having covered 84 miles. The leading Cadillac had a second Cadillac in tow, disabled through a collision with a tree. The other starters, Peerless and Maxwell, have not reported.

**DAYBREAK START FOR BRIARCLIFF RACE.**

The start of the Briarcliff Cup race for stock chassis has been fixed at 4:45 a. m. on Friday, April 24, the machines being sent away from a point opposite the Briarcliff Manor. The grandstand privileges have been sold outright, the money so obtained, together with the entry fees, being sufficient, according to the committee, to ensure financial success.

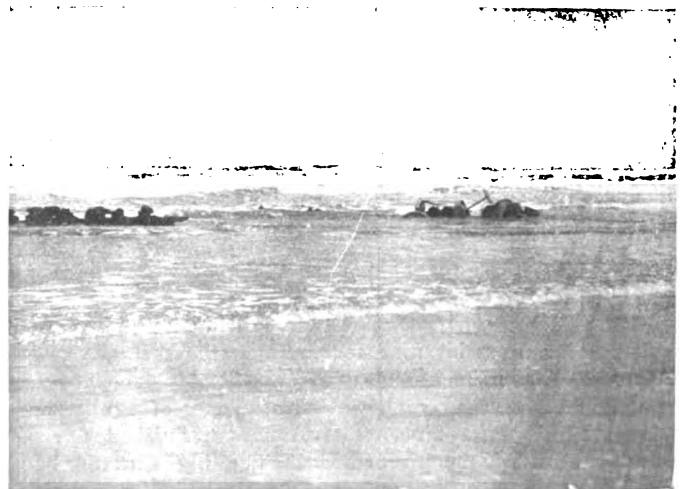

Old Wreck Which Wrecked the Cleveland.

# THE PERFECTION OF AUTOMOBILE IGNITION\*

By J. O. HEINZE, MEMBER SOCIETY OF AUTOMOBILE ENGINEERS.

WHAT has been troubling us more than anything else about an automobile and its engine is to perfect an ignition system that shall be accurate and positive. Daimler used in his early engines a separate iron chamber which was attached to the cylinder and opening into it, which was kept very hot by an outside flame. Into this chamber was injected a spray of gas, or crude oil, which ignited by coming in contact with the hot walls. Later on he employed a small closed platinum tube inserted and opening into the cylinder for the same purpose. The great objection to this system was the inability to definitely fix the moment of ignition in relation to the position of the piston in the cylinder and to insure at all times a positive ignition for every explosion stroke; also, in not being able to make the ignition rapid enough to propel engines at high speed in order to increase the power of the engine without increasing its weight. Otto used another form of ignition, differing from Daimler's, employing a separate gas flame burning near an opening in a slide valve, which carried momentarily a part of the flame into an opening in the cylinder, but he experienced the same difficulties that Daimler did.

My topic is the present-day electrical ignition and the various systems employed, also their mechanical construction and relative efficiency. I do not wish to refer to any one particular make of ignition apparatus, for I believe they all have merits, and the fact that much of our apparatus in the past did not prove efficient was because the various makers of ignition apparatus were not thoroughly equipped with instruments for standardizing their work. It was not because they did not see the wisdom of thus making absolute measurements of all the elements entering into the design of ignition apparatus, but such instruments for making measurements of this kind had not been designed and we were all, therefore, laboring under difficulties and guessing at results. Also, many of our past failures in the efficiency of apparatus were not due so much to the principles involved as they were to poor workmanship and general design, not using the right kind of material nor the proper proportions to give strength and durability.

## Automobile Requirements Were New.

When I first began the manufacture of ignition apparatus, and particularly spark coils, some three years ago, I entered the field with some fifteen years of experience in making spark coils producing from one-half inch to fifty-inch sparks in length, and naturally thought I was well equipped for making coils for automobiles, but I soon discovered that there are tricks to all trades, and while I was able to easily make a coil to produce a half-inch spark, still it would not do the work satisfactorily, for it would not respond to high engine speeds; nor was the explosion very strong, and the battery would discharge in a very short time, due to a large current consumption and many other defects, reducing the life and durability of the apparatus, owing to the conditions to which they were subjected in an automobile, such as vibration, heat and cold, and one other element, the desire of every automobile driver to locate all his troubles in the ignition apparatus. If his valves did not seat properly and he had no compression the spark coil was at fault. If his spark plugs got sooted by too much oil and carbon, it was the fault of the coil. If the gasoline pipe got plugged and the carbureter did not get any gasoline, he would try to find the fault in the coil.

Having briefly rehearsed a little history familiar to you all, I will now state some of my observations and experiences during the past few years. We all know that what is needed is a very hot spark, of great frequency, positive, and of a certain length, to penetrate the gap in the spark plug which is generally from

1-64 to 1-32 inch. We also know that with higher compression in the cylinder the spark should be longer and of a higher voltage, or, to be more precise, it requires a good 1-2 inch spark to jump a 1-32 inch gap at 90 pounds compression, and only a 1-4 inch spark at 60 pounds. The heat of the spark depends entirely upon the watt energy consumed in the arc of the gap, or, in other words, the sum of the voltage multiplied by the amperage passing through and across the spark gap. But since the voltage across the spark gap becomes practically nothing after the resistance of the gap is broken down and the arc formed, the amperage then depends entirely upon the ohmic resistance of the secondary of the coil and the total energy induced in the secondary, and this energy again depends upon the mass and quality of iron in the primary, the ampere turns on the primary core, producing a certain total magnetic flux and the rapidity with which the primary current is interrupted, and from this analysis it would appear that the larger the iron core, or the larger the coil, the hotter the spark to be obtained. Quite true,

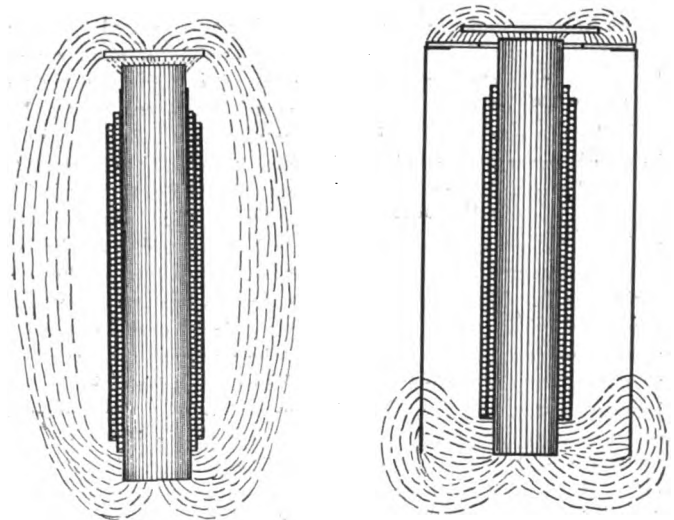

Figs. 1 and 2.—Showing method of closing magnetic circuit.

but we must figure on the frequency of the spark necessary to operate an engine at high speeds, and here we meet with a limitation in the size of spark coils practical for gas engines. We find that we have got to magnetize and demagnetize the primary iron core to produce an induced current in the secondary and as the iron core and its vibrator have a fixed time lag, depending upon the mass or iron in the core, the mass of the vibrator and the length and tension of the vibrator spring, we can therefore produce only a certain number of sparks per minute in a certain size coil, as a certain frequency is necessary for a definite engine speed. This frequency would then determine the size of the coil, and the size of the coil determines the total electrical energy which can be produced by it in the heat of the spark. With a magneto, however, we have no limitations, for, being practically a dynamo-electric generator, the larger we make the machine the more energy we can get in producing a longer spark and of greater amperage, and where a magneto is of the low-tension type, we have practically no lag, and could produce sparks far more rapidly than is necessary for present-day engine speeds. Magnetos which generate a low-tension current (mechanically interrupted) passing through the primary of a coil and stepping up the voltage by the secondary, have only the magnetic lag of the primary core and the armature core to contend with, and this arrangement would make possible far

\*Paper read before the Society of Automobile Engineers at New York.

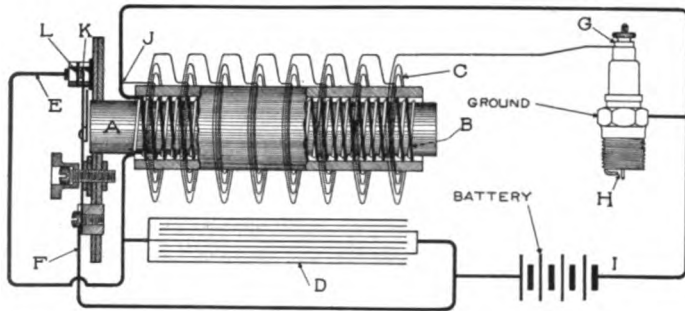

Fig. 3.—Details of spark coil and connections.

greater engine speeds than would be mechanically safe. So I will have to confess from my experience that a spark coil using a vibrator operated by either a battery, magneto, or small electrical generator will never produce the same results, or efficiency, produced by a magneto operating through a mechanical electrical make-and-break in the cylinder or on the magneto and stepping up the voltage for jump spark ignition through a non-vibrating induction coil.

**Ingenious Instruments for Coil Testing.**

In order to demonstrate more clearly the principles involved in spark coils, and the means of arriving at standard results of efficiency, I have designed several instruments for making absolute measurements for the purpose of testing the efficiency of various kinds of coils and secondary windings, comparing them with the results obtained with magnetos. Fig. 1 shows a primary iron core commonly employed in spark coils having wound consecutively upon it two layers of primary winding, through which pass the battery current, producing magnetic lines of force which pass through the iron core, and from one end of the core through space to the other end of core, so completing the magnetic circuit. Fig. 2 shows another form of primary core and winding having plates of iron on each side of core for the purpose of more thoroughly completing the magnetic circuit by iron to strengthen the magnetic field and to get a greater number of lines of force. And as the current induced in the secondary depends upon the strength of this magnetic field, the stronger we make it the longer the spark and the greater the amperage produced from it without consuming any more current. This form of construction is used in the Heinze type of coil.

In Fig. 3 we have the general arrangement of a spark coil; A is the iron core, B is the primary winding, C is the secondary winding which consists of some 20,000 turns, D is the condenser consisting of layers of tin-foil insulated from each other by layers or sheets of mica or paraffined paper, and which is connected across the vibrator at E and F, one end of the secondary winding being connected to the spark plug at G, completing its circuit after jumping the gap H in the plug, and passing to the ground connection formed by the cylinder to one end of the battery circuit I and through the battery to the primary winding to which the other end of the secondary is connected at J. When the primary current passes around the primary winding it magnetizes the iron core; this then attracts the small iron plate of the vibrator, and in so doing breaks the electric current at the contacts K and L and as the current ceases flowing around the iron core it quickly demagnetizes and this rapid decrease and increase of the intensity of the magnetic field is what causes a current to be induced in the secondary winding. The voltage or spark length produced by the secondary depends entirely on the number of turns of wire in series and the total magnetic flux and its rate of fluctuation from minimum to maximum in intensity. The condenser D is for the purpose of quickly absorbing the back rush of current from the primary at the moment of break and thereby eliminating the sparking at the contacts. Unless the condenser is properly proportioned in its relation to the primary winding, mass of iron and battery current, excessive sparking will be the result with

consequent pitting of the contacts. It therefore becomes apparent that every element, such as the microfarad capacity of the condenser and the magnetic qualities of the iron should be carefully tested and standardized in order to get uniform and efficient results. For the purpose of testing the magnetic quality of the iron and its ability to quickly magnetize and demagnetize I designed the instrument shown in Fig. 4, known as a *Hysteresis Tester*, which consists of an iron core, A, B, C, D, E, F, of U-shape. On the cores A, B, and E, F are wound small coils G and H, and between the pole-pieces I and J is mounted a small circular iron core. Around this core moves a small coil of wire pivotally mounted, to which is fixed an indicating needle L, moving over a graduated scale K. Small non-magnetic clock springs are secured to the coil pivot and keep the needle at zero. A direct current from a battery producing a certain number of milli-amperes passes through the moving coil on its pivot and through the coils G and H in series. The iron core M of the spark coils to be tested is revolvably mounted between the cores A and F and completes the magnetic circuit. If we now pass a certain number of milli-amperes through the coils G and H and the pivot coil, the iron core to be tested remaining stationary in the position shown in the diagram, we then get a certain deflection of the needle L over the dial K. If we now rotate the iron core M about its axis at a fixed number of revolutions we then get a new reading on the scale. The magnetism generated by the current in coils G and H and passing through the rotating iron core in the direction as indicated by the dotted line, reverses in direction through the rotating core twice during every revolution. If we now rotate this core 2,000 revolutions per minute we would get 4,000 reversals of magnetism. The number of degrees of deflection of the needle on the scale depends upon the strength of the magnetic field, and if the iron core does not readily demagnetize and magnetize during its revolutions it would naturally reduce the total strength of the magnetic field and the indicator would show a small reading on the scale. So by this method we can show absolutely whether an iron core is susceptible to rapid magnetic changes necessary

for producing a coil to give a great frequency of sparks per minute, and for the purpose of seeing that our iron is twice alike, for if it is not repeated, annealing will usually make it so.

To test the frequency of the sparks from a coil I designed the instruments shown in Fig. 5, which consists of a rotating needle A on its axis B, within a graduated ring C, of a known diameter and divisions. One end of the secondary D of the coil connects to the rotating needle A, and the other end of the secondary E connects to the ring C. The needle A, at its point F, is sep-

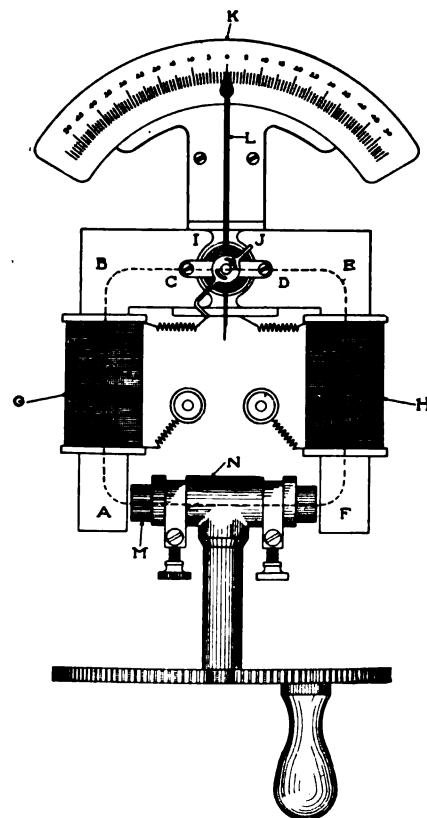

Fig. 4.—The Heinze hysteresis tester.

arated 1-4 inch from the ring C, so that sparks leap across this gap from the point F to the ring. If we now rotate the needle a certain number of revolutions and we have a certain circumference in the ring, by multiplying the number of the sparks per inch times the number of inches in the circumference of the ring, times the number of revolutions of the needle, we then get the number of sparks per minute. With this instrument we can easily test different makes of coils having various kind of vibrators, and can also learn the effect on the number of sparks produced per minute by varying the tension of the vibrator as well as determining the amount of current consumed, thus arriving at the best form of construction to give the greatest efficiency.

Fig. 6 is an instrument for measuring the approximate temperature of the spark of different spark coils and magnetos.

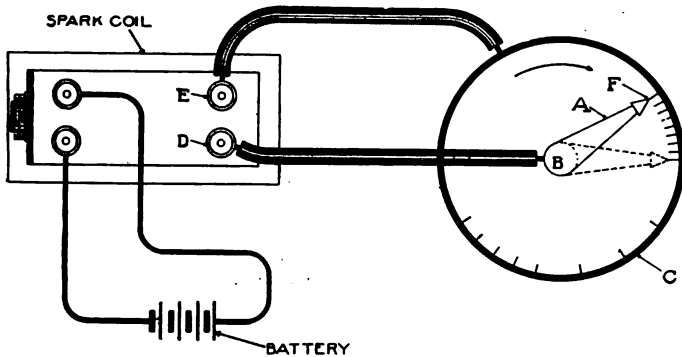

Fig. 5.—Heinze instrument for testing frequency of sparking.

This is not determined in Fahrenheit degrees, but in heat units. The instrument is designed on the principle of utilizing the expansive effect of a hot wire to move an indicator needle over a graduated dial, and is constructed as follows: A fine copper wire is stretched between the metal contact posts, A and B, the tension of this wire being regulated by the adjusting screws K and K'. To the center of the wire at C is fastened a small copper stud, which comes to within 1-32 inch of the metal plate D. The secondary terminals of the spark-coil are connected to the binding posts L and M, completing its electrical circuit through the copper wire N, across the gap at C, to plate D. If a certain amount of primary current, determined by an accurate ammeter, is passed through the coil, we will get a continuous secondary spark between the stud C and the plate D. This spark heats the stud and in turn heats the copper wire which expands and causes an elongation in the direction of the arrow E. To the center of the wire and the stud C is also fastened a small wire, to the end of which is fastened a silk thread, wound around a pivot and kept taut by a small spring H. To the pivot is fastened an indicator needle moving over a dial I in the direction of the arrow G, when the wire is expanding, and in the opposite direction when contracting, giving us a certain reading depending entirely upon the temperature produced in the copper wire by the heat of the spark at the gap C. When the rate of cooling, or radiation, of the wire equals the production of heat from the secondary current, the needle will then come to a stop and no fixed time measurement is necessary. In order to test various coils, it is first necessary to see that they all consume the same amount of primary current at the same voltage. When comparing the spark from a magneto with a coil, I found that the magneto produced from 500 to 1,000 per cent. more heat units in the spark gap of the plug, over a coil, so the importance of having an instrument making absolute measurements possible, thereby eliminating the personal factor, may be appreciated.

Fig. 7 is an instrument for measuring the amount of lag in the secondary spark from the moment the primary current is closed, and my object in designing this instrument was to clear up a prevailing idea in the minds of many automobile operators that by advancing the timer an early ignition is produced when

the piston is still coming up. From the many experiments which I made in ignition timing, I found that it was impossible to advance the spark more than 10 degrees at an engine speed of 1,000 r.p.m without observing a slight decrease in power; if the advance was carried further, the engine would gradually come to a stop, or kick back. The higher the engine speed the more the spark can be advanced, but no such advance is possible as would be indicated by the position of a timer apparently capable

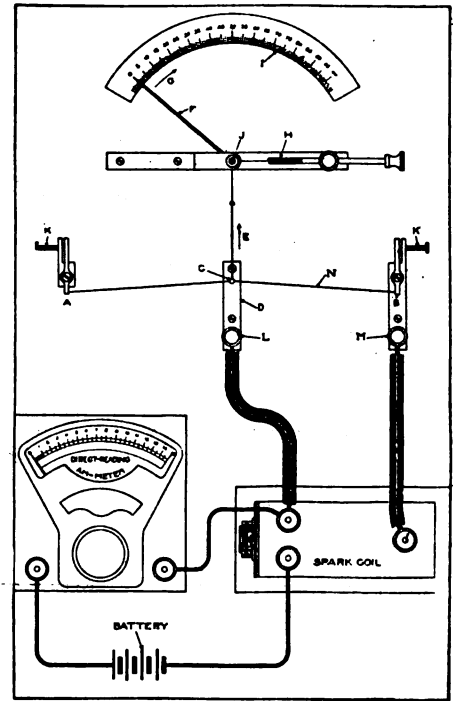

Fig. 6.—Heinze hot wire pyrometer.

of a movement of 90 degrees, or more. This great amount of advance of the timer is necessary to overcome the enormous lag in vibrating spark-coils, but no such advance is possible with a magneto, for the secondary spark takes place immediately at the moment of the primary current interruption. The only lag present is entirely magnetic, and there is none in the contact, for the mechanically-operated contact breaker in a magneto increases in speed with the engine, but the vibrator of a coil has a fixed lag, or in other words takes just as long to start vibrating,  
(Continued on page 379.)

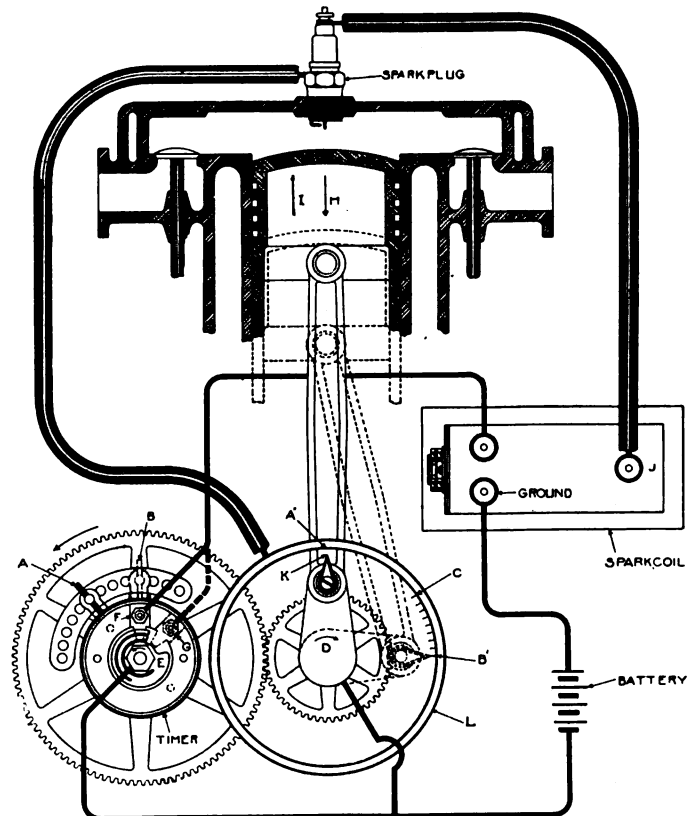

Fig. 7.—Details of Heinze analogue for testing ignition advance.



## REMARKABLE WORK OF BACKWOODS INVENTOR

By VICTOR LOUGHEED.

IT has not often been the case that any considerable progress in automobile design has come from small and isolated communities, as the result of independent individual effort, but to all rules there are exceptions. Though the automobile has been chiefly regarded and is for the most part a product of the cities and more populous areas of civilization, it is none the less a fact that in the development of a mechanism having all terra firma for its field of usefulness there may be much of merit in the ideas of the man who, spurred by a knowledge of exceptionally demanding local conditions, brings out something specially adapted to cope with them. Such has been the genesis of the really remarkable automobile truck illustrated herewith, which, besides being a demonstrated success, is exceptionally noteworthy in having been entirely designed and constructed by a country blacksmith, Arthur Mills, of Ione, Cal.—a small mining town almost as remote in point of accessibility from the populous



Blacksmith Arthur Mills' Ore-laden Automobile Train.

sections of the Pacific slope as it is from the motor building centers of the East.

Over fourteen years ago, it has developed, Mr. Mills first commenced pondering over the problem of mechanically-propelled vehicles for common roads, and almost as soon commenced the work that has eventually embodied his ideas in useful form. This period of work, carried on absolutely without more than local publicity, and without the sale of a machine—none having been placed on the market even yet—is worthy of note in that it classes Mr. Mills with the very pioneers of American automobile manufacture, with perhaps especial credit due because all that he has accomplished has been done in spite of the handicap entailed by a lack of facilities for the interchange of ideas with other workers in the same field.

Mr. Mills' work has been from the first consistently in the commercial vehicle field, a keen recognition of the fact only recently discovered by many others that in the last analysis the importance of the automobile must rest, not upon passing fads or fancies, but upon solid worth and utility. And, more even than this, it is to be said for Mr. Mills that he has achieved as successful a design, by strictly following his own ideas and methods, as many others have with the aid of all that a growing standardization and uniformity of practice could afford, for it is only within a very recent period indeed that the makers of trucks and commercial wagons generally have been able to supply machines really satisfactory from the customer's standpoint.

The first Mills truck is the one illustrated herewith, it being a 4,500-pound machine, capable of carrying a load of 3,300 pounds over the worst roads and hardest gradients, while at the

same time touring a heavy trailer with a 6,500-pound load. This machine was completed several years ago and was in more or less regular service until very recently, when it was torn down that some of its parts might be used in the model that followed it. As is suggested by the illustrations, anything from hay to ore can be hauled, these being the usual loads transported in the particular class of mountain service to which its activities have been confined. No great speed is attempted, the roads around Ione, Plymouth (where the truck was built) and other points in Amador county being of a character to discourage speed, even when the power for it is available. Both in the matter of heartbreaking hills and atrocious surfaces—deep sand and mud, broken rocks and boulders, and excessive grades—there probably are none worse in the country than these primitive highways of California's earliest mining district. Yet with only six horsepower, though of course at low speed, this original Mills truck time and again, month in and month out, proved its ability to go and keep going with heavy loads without ever becoming stalled. Trips to Sacramento and even to San Francisco, on occasion, proved a capacity for long distance travel.

In mechanical detail the features of principal interest probably are the enormous wheels, shod with regulation steel tires—except for the use of small knobs at intervals on the driving wheels to help traction, the wide tread, and the peculiar arrangement of the power plant. The wheels are 58 inches, the tread 62 inches, and the wheelbase 174 inches, making the machine about 20 feet long over all.

The motor was a 6-horsepower, two-cylinder, vertical, four-cycle engine, located crosswise under the front seat and presenting no unusual features—both valves being mechanically operated, the cooling being by water, ignition by jump spark, etc. Speed changing was by a novel individual clutch system, with double bevel gears, affording two speeds forward and reverse. From the change-speed gear the drive was by single chain to the solid countershaft, the spur pinions on the ends of which drove directly into internal gears bolted on the insides of the rear wheels. No differential was used, releasing clutches between the internal gear rings and the wheels providing for automatic disengagement of one wheel by an inter-connection with the steering gear.

The steering gear is of the fifth-wheel pattern, controlled by a sector and pinion, the latter on the base of a vertical steering wheel. The reduction is so very great as to make irreversibility unnecessary and the fifth-wheel construction unobjectionable, it being remembered that the speed is very low.

Seven miles on a gallon of gasoline was the fuel consumption. Forty-five gallons were carried.

A new truck, containing parts of the old, has just been completed. It weighs 6,500 pounds and can carry five tons, besides drawing a trailer carrying five tons. The motor is a 14-horsepower of the same type as the first and the transmission is similar. The wheels are 48 inches front and 50 inches rear, the tread 62 inches and the wheelbase 150 inches. Thirty-five gallons of water are carried in a dummy bonnet, under which the gasoline tank also is located, and serves for cooling without any more radiating surface than is afforded by a few lengths of ordinary half-inch piping. A Schebler carbureter is used, and muffler cut-out is provided. Five miles per gallon is fuel use.

Throughout the vehicle a special point is made of the entire lack of special steels and materials. It is thus possible to effect repairs in any blacksmith's or wheelwright's shop, just as the entire machine has been hand built by Mr. Mills with the meagerest facilities. Despite this lack of alloy steels and the like, it is to be noted that the weight of the vehicle is not in excess of that of others of similar capacity.

## LETTERS INTERESTING AND INSTRUCTIVE

### WHAT IS THE AUTO'S FACTOR OF SAFETY?

Editor THE AUTOMOBILE:

[1,213.]—As I am considerably interested in the design of automobiles, I would be pleased if you would inform me what factor of safety is used in proportioning the different parts, such as side frames, driving shafts, transmission gears, and axles. I have been informed that the factor of safety depended upon the difference between the elastic limit and the ultimate tensile strength, but I do not know to what extent, and have no specific data for determining this, and have been unable to find any books containing such, so I would be pleased if you could help me out. Vanadium steel is what I was thinking of most especially.

Does "The Automobile Pocketbook," by E. W. Roberts, contain any such information as I have asked for?

Bison, Okla.

F. M. VANDERVOORT.

It would be impossible to state definitely exactly what factor of safety is generally allowed in the design of automobile parts, as this is something that naturally varies with each designer, but generally speaking, it may be said that it is very high; the maximum permissible consistent with keeping the weight within proper limits. In spite of this limiting factor, it is probably safe to say that the factor of safety of the automobile, as a whole, is very much higher than almost any other piece of machinery marketed generally, owing to the excellence of the materials employed. We have never heard of the factor of safety being made dependent upon the variation in the characteristics of the material, such as you state. In calculating the factor of safety in any given case, the maximum safe ordinary working load is taken as a basis, and the strength of the parts increased to make as great a margin of safety as is deemed to be necessary in view of the nature of the load to which the structure is to be subjected.

While Roberts does not make special reference to this subject under a separate heading, we think you will find it mentioned from time to time in connection with the design of various parts in "The Automobile Pocketbook." For instance, in connection with automobile chains, he says: "It is very seldom that an engine will develop its full power when the car is running on low gear, and a factor of safety of five will be found quite customary practice when calculating the strength of the chain on this basis. So a chain having an ultimate tensile strength of 5,000 pounds should not be subjected, under working conditions, to a strain of over 1,000 pounds."

### BEST ROUTE, SPRINGFIELD TO ALBANY.

Editor THE AUTOMOBILE:

[1,214.]—A party intending to make a trip to New York State this summer desires information as to the best route between Springfield, Mass., and Albany. Can you or any of the readers of this magazine who have been over the several routes give any light on the subject? How long can an owner of a Connecticut car tour about New York State without getting his car registered in that State?

ROBERT E. HARRIS.

Putnam, Conn.

At the present time the direct route between Pittsfield and Albany via the Lebanon, Brainard and Nassau is closed by order of the State Engineer, in connection with the considerable improvements and reconstruction of the line, and there is no knowing when this route will be open to travel again. For this reason, it is necessary either to push through the improvements in process, or make a detour from some point south of Pittsfield (usually Stockbridge) to State line; thence west through Chatham and Valatie, meeting the Poughkeepsie-Albany line about twenty miles below Albany. Maps of both the regular route and this special route will appear in the New England edition of "The Official Automobile Blue Book for 1908." Under the present law any automobile may remain indefinitely in New York State provided it is equipped with a regularly issued license from any other State.

### POINTERS FOR A PROSPECTIVE PURCHASER.

Editor THE AUTOMOBILE:

[1,215.]—Will you kindly give me your private opinion as to (1) whether a two-cycle, double opposed motor, shaft drive, placed under the hood in the front of the chassis, is as serviceable; i.e., will it have the motive power for heavy roads, such as for mud, hill climbing, etc., as when the weight of motor is placed under the hind axle? (2) Is a 15-16-horsepower outfit better than an 8-10-horsepower for general use in the country for poor roads, hill climbing, etc.? (3) Would it be feasible to use a set of steel tired wheels for muddy and poor roads; i.e., will they give the resistance necessary for practicability, and would it cause too much jarring for the motor? Or would it be better to have solid tires?

My idea was to get a motor and use two sets of wheels; one set with steel tires and the other pneumatic, for use when the roads are fine. (4) What is the best height and width of tire for the wheels for use (hills and mud) as stated in the former query? (5) Is an air cooled machine of given horsepower just as serviceable and practicable as the water cooled, or has it disadvantages?

Contemplating purchasing an auto, these are a few points on which I wish some light before investing. J. C. HUBENTHAL.

Belmont, Wis.

1. This will depend upon the design. If the latter be such that a sufficient proportion of the load comes over the rear wheels, the motor forward will be serviceable and probably more convenient than when placed in the rear. Putting the motor over the rear axle and designing the car so as to carry most of the weight of the load there, would give poor balance.

2. The larger motor would naturally be more desirable for poor roads and hill-climbing, as these present conditions under which the maximum power, consistent with light weight, is an essential.

3. Steel tires would not be practical, whether on good or bad roads, as they would not give the desired amount of traction, and they would subject the motor to excessive pounding, except at very low speeds. Solid rubber tires would naturally be preferable. The idea of using steel-tired wheels in fair weather and pneumatics in stormy weather is hardly feasible, unless you intend to carry both sets with you at all times and get out and change whenever necessary.

4. This would depend upon the weight of the car, and if the latter were not great, a two or three-inch tire on a 42 or 44-inch wheel would be advisable, particularly for mud.

5. This is largely a matter of personal opinion. In some cases the air-cooled motor has been found superior.

### WHAT IS WRONG WITH THIS CARBURETER?

Editor THE AUTOMOBILE:

[1,216.]—I would like to ask you about the setting of the carbureter on our Pierce Great Arrow car, 28-32 horsepower, 1906 Model, which is the special carbureter used on most of that date Pierce cars. During the past year we have averaged five to six miles on a gallon of gasoline. But lately have raised and lowered the float and changed the opening of needle valve, with no better results. Can you suggest how I can get more miles to the gallon with the present carbureter? Some suggest setting the float so the gasoline will raise 1-32 inch below the spray nozzle. Do you think that right, or would you set the float higher? And what position should the spark and throttle level be in to test the carbureter while car is standing still? Inclosed find drawing of the carbureter. Do you think some other make of carbureter would do better on this car?

Ithaca, N. Y.

W. J. WILSON.

The level of the gasoline should be 1-16 inch below that of the opening of the nozzle. It is customary to test a carbureter by closing the nozzle to a point where just enough gasoline is vaporized to run the motor without missing at its slowest speed, the spark advance lever being placed at the usual starting point. This is done by starting the motor and gradually closing the needle valve until the motor will no longer run without missing. It is then opened slightly again until the missing disappears, and made fast at that point. The needle must be turned very little at a time. The motor

is then speeded up and the auxiliary air intake of the carbureter adjusted to give the best results. Just what opening there should be for the different speeds may be learned by closing the opening, either with an improvised disc, that may be opened or closed as desired, or by placing the hand over the outlet and allowing more or less air to enter, according to the action of the motor at the different speeds.

The mileage you have been averaging is very low and may not be the fault of the carbureter altogether. Probably not at all, as there may be considerable loss of compression round either the pistons, or through the valves, which would account for the excessive amount of fuel required to do the same work. We should not recommend changing the car-

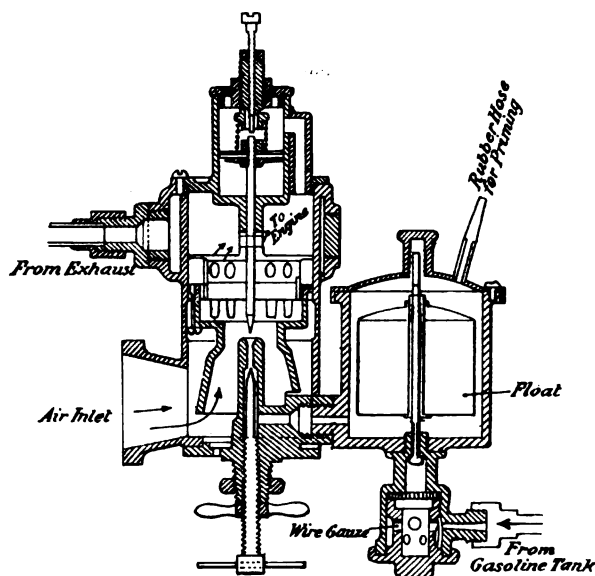

Section of 1906 Model Pierce Great Arrow Carbureter.

bureter without investigating the cause of the lost power more thoroughly and think an appeal to the makers of the car for information would be the wisest step to take, before making any radical changes of this nature. The makers of the Pierce cars have changed the design of their carbureter considerably since the type shown was made, by making the float chamber concentric with the nozzle and by making changes in the air-valve mechanism.

#### HOW MANY CANDLEPOWER ARE REQUIRED?

Editor THE AUTOMOBILE:

[1,217.]—Please answer these questions in the next issue of "The Automobile." How many candlepower would a light have to have to give same amount of light as is given from a 7-inch searchlight? Lamp to be 6-volt, and is to be put in place of burner in searchlight.

I have a Ford runabout with a Kingston carbureter on. I can adjust this carbureter so machine will run fine for perhaps ten miles or maybe it will only run a short distance. All at once engine will slow down and just run, but if I change the needle valve sometimes one way and sometimes the other, it will run fine again for a way. Tanks and pipes are clean, so is carbureter. All connections are tight and valves do not leak. A friend of mine has same trouble. If you can help us out, we will appreciate it very much. We are both subscribers to your paper.

Oregon, Ill.

F. R. ZIEGLER.

It is impossible to answer your question from the data you give, as the candlepower required does not depend upon the size of the searchlight as much as it does upon the size of the burner employed. Generally speaking, however, it will not be possible to obtain the same efficiency with a searchlight designed for acetylene, as the light of the latter is concentrated in a very small area, whereas the filament of the average incandescent electric lamp occupies a comparatively greater amount of space. This is a query which we

prefer to put up to the experts employed by the lamp manufacturers, who will doubtless come to your aid in this column.

From your statement of the carbureter trouble, it seems apparent that when you have the needle properly adjusted you do not fasten it in place and the jolting consequent upon running the car causes it to loosen up. Once the needle is set for regular running, and this should be at a point where the motor is just getting gasoline enough to run at its minimum speed without missing, the locknut should be tightened, so as to hold the needle permanently at that adjustment. It may be that the threads have worn.

#### A PECULIAR FORM OF MOTOR TROUBLE.

Editor THE AUTOMOBILE:

[1,218.]—I drive a Premier "24" car, and am frequently annoyed and delayed by the actions of the carbureter, which is of the Schebler make. At times when I want to crank up, the carbureter belches gasoline out of the air intake, and I can do nothing to stop it. I simply have to crank and crank until the carbureter quits doing it. Sometimes I am delayed as long as an hour at a time. My motor runs along excellently, and when I stop there is no indication of trouble, but when I want to start up again, nine times out of ten it is all right. The other time, though, I am up against this trouble. This is in summer and winter alike, so I don't believe that it is produced by the condition of the weather. The valves are in excellent condition, so it cannot be because of them. Whenever this trouble arises, investigation shows that the needle valve is not sticking, nor are there evidences of any kindred troubles. I wish you would give me your opinion on this subject, through the columns of your paper, as I have exhausted my own resources, as well as those of all the garage men I know.

Chicago, Ill.

L. M. G.

It is evident that the only thing which can cause such action is the escape of compression from one or more of the cylinders through the air intake of the carbureter. Where does this compression come from? Granted that a carbureter is a mysterious device to the average autoist, and to many an otherwise skilled repairman as well, still it is not capable of producing compressed air or gas of its own accord. This compression must come from one of the cylinders; the only means by which it can find its way into the manifold is through a defective valve, and once in the manifold, the only way of escape is through the carbureter. If you are quite certain that the assumption that the valves are all right is sound, then there is a mystery to be explained, but we think you will find that a closer examination of the valves will destroy the assumption. Their seatings may be in good condition, but a stray piece of carbon, a weakened valve spring or some similar cause may prevent one of the valves from seating properly at times, and the spasmodically recurring nature of the trouble would indicate that it is only by chance that this condition is brought about. The escape of compression prevents any fuel from entering the cylinders, and naturally the motor cannot be started until it has been turned over long enough to dislodge the cause, whatever the latter may be. It is an injustice to the carbureter to attribute the trouble to it, and we think you will find a closer examination of the valves and their operating mechanism will reveal the cause. If any of our subscribers have a theory of their own in the matter we will be pleased to hear from them.

#### "THAWING" OUT A MOTOR IN SPRING.

Editor THE AUTOMOBILE:

[1,219.]—Will you please tell me how to thaw out a gas engine before spring? It is a 3 1-2 horsepower Palmer engine in a small launch, and as the boat is pulled up for the winter, I would like to try the engine before letting it down in the spring. Kindly inform me through the columns of "The Automobile."

Andover, Mass.

L. D. F.

"Thawing" is rather a peculiar way to put it, unless you have neglected to drain the water-jacket before laying the boat up for the winter. Even in such a case it will not need any thawing by the time you get around to it in the spring, but will doubtless need a little more serious consideration. Prob-

ably you intend an "overhauling" or "limbering up." This may consist of anything from a mere cleaning to a total dismantling of the motor. If you only wish to do the former, flush out all the bearings thoroughly with gasoline, including the piston, see that the gasoline tank and piping and the carbureter, as well as the whole ignition system, are in good order and everything is clean. Provide fresh cells for the ignition battery, and after the gasoline used in the cleaning process has all evaporated from the interior apply fresh lubricating oil and the motor is ready to start.

#### SHOULD REAR-WHEEL FASTENINGS BE RIGID?

Editor THE AUTOMOBILE:

[1,220.]—In the method of fastening the rear wheels upon their axles, as described, it is impossible to entirely obviate some play between the axle and hubs by most careful adjustment of keys and pins. Is this looseness undesirable, and will it work ultimate injury to the car? The play is not in the direction of the wheel motion; i. e., tendency to shear off the key, but is noticeable when the wheel is grasped at two opposite points of the tire, and a to-and-fro motion in the direction of the axis of the axle applied.

The construction is as follows: Axle, cylindrical; no taper; a hub with a key-way its full length, but other portions being a sort of web, so that it bears upon the axle at its center and at both ends for a distance in each instance of about 3-4 inch. Near the outer end of the hub is a hole with a corresponding hole in the axle, through which a pin is driven.

As I am anxious to keep my car in the best of condition, your opinion on the above will be much appreciated.

Alameda, Cal.

MAURICE W. BROWN.

This slight amount of side play in a rear wheel is not an element of danger. Unless it be excessive, it is rather a factor of safety than otherwise. If the wheel were rigidly held laterally, it could not be turned easily and the friction would be tremendously increased.

#### SOME PRODUCTS OF AN INVENTIVE GENIUS.

Editor THE AUTOMOBILE:

[1,221.]—I have invented a device to put on an auto crank to release the engine when it kicks. I have also an idea which will roll a clincher tire off a rim as fast as those that are now made and can be made for one-quarter the cost of those on the market. I have a few more ideas, and I think it will pay you to investigate, and I am not afraid to show them. I am twenty-two years of age, and would like to get these on the market, as I think there is lots of money in them.

H. L. SKOLINK.

Chicago, Ill.

You evidently have been making a close study of the various parts of the automobile that are in need of improvement. We are always interested in learning of such devices, and in publishing them where their merit is such as to warrant it. Further than this, we cannot help you to market them, and would recommend your writing to manufacturers who make a specialty of this. You will find the announcements of a number of them in our advertising columns. The large tire manufacturers are always keenly interested in anything that will be an improvement over present methods.

#### CONCERNING VALVES IN THE HEAD.

Editor THE AUTOMOBILE:

[1,222.]—Will you kindly publish the names of four-cycle cars now using valves in the head? Can you give me the number of years each of the cars have used this system? Can you give me the name of any four-cycle car which formerly used valves in the head but has now given up the practice? SUBSCRIBER.

Cedar Rapids, Ia.

The Matheson, Moon, Pope-Toledo, Pope-Hartford, Dorris, Mitchell, Franklin, Jackson, Knox, Marmon, Frayer-Miller, Stoddard-Dayton and probably several others, as the foregoing only happen to constitute a list of those easily recalled to mind at the moment. Some motor manufacturers, such as the makers of the Northway and others, also employ this design. The first six cars in the list have had motors of this type for three or four years, in some cases longer, and this is also true of the Knox, Marmon, Franklin and

Frayer-Miller. In the majority of the foregoing instances, the motors have never been equipped with any other type. We can not recall an instance in which this design has ever been abandoned.

#### VOLTAGE AND AMPERAGE OF IGNITION CURRENT.

Editor THE AUTOMOBILE:

[1,223.]—I am a constant reader of your "Letters Interesting and Instructive." Will you please tell me, through your columns, the voltage and amperage of the secondary wires of a Splitdorf spark coil when run by four dry cells? I mean the current that makes the spark.

O. O. D.

Fishkill-on-Hudson, N. Y.

Under favorable running conditions, vibrator coils require a fraction of an ampere for their operation, say .75, while four dry cells will have a voltage of six when new and connected in series. The current and voltage of the secondary current will then depend entirely upon the number of turns in the primary and secondary windings of the induction coil which transforms it, or "steps it up" to the high voltage. In letter 1,179, issue of THE AUTOMOBILE of February 20 last, Frederick C. Hathaway goes into this subject more in detail and we would refer you to his letter, which will be found on page 249 of the number in question.

#### WHICH GEAR SHALL I BUY?

Editor THE AUTOMOBILE:

[1,224.]—Would you kindly advise me what transmission you would recommend for a 16-horsepower opposed motor engine? I wish the planetary type. There is such a difference in price that I can hardly tell what to buy. The New York can be bought for \$37 and the Syracuse Gear Company asks \$60 for the same power size.

Pringhar, Ia.

JOS. REYNOLDS.

We are in no better position in this respect than you are. Doubtless the maker of the more expensive gear has good reasons for asking a higher price, and will be glad to inform you what they are upon application. You will find that there is quite a difference in quotations on any kind of machinery where made by a number of different manufacturers. It all depends upon the design, material, workmanship, conditions under which it is produced and the like. It is a matter that you will have to decide for yourself, after carefully weighing all the claims one way or the other.

#### ABOUT KEROSENE vs. DECARBONIZING FLUIDS.

Editor THE AUTOMOBILE:

[1,225.]—Will you kindly inform me, under the head of "Letters Interesting and Instructive," whether the various decarbonizing fluids and mixtures advertised so freely contain ingredients that are injurious to the engine? Also are these patent preparations any better in the long run than simple old-fashioned kerosene?

Walden, N. Y.

CARBON.

Never having analyzed any of the preparations in question, nor having come across a published analysis of their ingredients, we are at a loss to state whether they might be injurious to the cylinder walls or not, but, on general principles, would be inclined to assume that they were safe to use. We do not know that there is anything better than kerosene.

#### USING LARGER TIRES THAN RIMS CALL FOR.

Editor THE AUTOMOBILE:

[1,226.]—Is it advisable to use 4-inch tires on 3 1/2-inch rims? Also, in adjusting a loose connecting rod, should it be made to work a little stiff?

Batavia, N. Y.

L. L. MULCAHY.

We have known of this expedient being adopted, but never had an opportunity of learning what the outcome was after an extended period of use. On general principles, should not think it to be advisable for several reasons, chief among which would be the difficulty of putting the tire on the rim, the danger of pinching the tube in the process, and more than either of these, the risk of rim-cutting. In adjusting any bearing, it should be made slightly loose, rather



than stiff; that is, just sufficient play to permit the shaft to turn easily, but not enough to make it noticeably loose. Even a slight amount of stiffness in the adjustment of each connecting rod bearing would make it next to impossible to turn the motor over by hand, from which it will be evident that a great amount of resistance would be imposed on the motor when running and until the bearings had been worn down so as to allow for a little play, it could not develop its full power.

### HOW TO READ A "COMPRESSION CHART."

Editor THE AUTOMOBILE:

[1,227.]—Please tell me, through "Letters Interesting and Instructive," how to read a compression chart. APPRENTICE.  
Parsons, Kan.

It is not quite clear to us what you intend by a "compression chart." If you mean a table of compression pressures it will naturally depend upon the arrangement of the latter and the manner of reading it will be self-evident. Probably you mean an indicator card, and if this be the case we would refer you to an article entitled "The Indicator Diagram and What It Means," by Victor Lougheed, which appeared in THE AUTOMOBILE of January 2.

### NO TROLLEY FROM NEW YORK TO BRIARCLIFF.

Editor THE AUTOMOBILE:

[1,228.]—Will you kindly supply the following information in "Letters Interesting and Instructive?" Is there a trolley connection between New York and the Briarcliff race course? If so, will you kindly state the route and fares? SUBSCRIBER.  
Freeport, N. Y.

There is no trolley connection between New York City and the course of the Briarcliff Trophy race. It may be reached by taking the Harlem road to Briarcliff Manor, or the Central to Ossining. The Briarcliff course is peculiarly off direct transportation lines, though it can be reached from other points than New York. A good map would help.

### THE PRACTICAL SIDE OF THE QUESTION.

Editor THE AUTOMOBILE:

[1,229.]—When an automobile weighing 2,000 pounds descends a 25 per cent. grade it is propelled by the force of gravity equal to one-fourth its weight, plus the propelling force of its motor. The retarding forces which must be overcome are total friction, air resistance, and the resistances to be overcome before the motor can deliver propelling power. These motor resistances consist of compression, scavenging, and the momentum of the piston and connecting rod at each end of its travel. Of these resistances, friction decreases as the speed increases, while the other three increase with the speed. If the motor is turned by force applied to the drive wheels, these resistances remain constant just the same as if the explosions overcame them, but the power to overcome the resistances must be taken from the gravity force which I have mentioned, instead of the motor power, and this leaves just that much less gravity force to propel the car down the grade. The faster the drive wheels turn the motor, the greater will be the resistance to be overcome, and the slower the car will move. Therefore, if we wish to use the motor as a retarder to car movement, we will get the greatest service by using high gear, with the spark and gas supply cut out. There should be plenty of air taken into the cylinders in place of the gas to secure the compression resistance to its fullest extent. Taking in gas does not differ in its results from taking in air, if the throttle be opened to its full extent. Therefore, to coast down hill using the motor as a retarder, we should have a convenient circuit-breaker and use the speed gear that gives the required resistance, high for steep hills, and intermediate or low for hills of less grade. The speed gear should not be thrown in after the car has added momentum to its propelling force as a means of bringing the car to an emergency standstill, except to avert very serious disaster, and then the act is very likely to produce a break which will release all control and lead to the very result that is so important to avoid. Under stress of this condition, first put on your hub brakes, burning them out by fierce friction if need be, then throw in slow gear to assist the other brakes. You may have some hub brakes to replace, but you will not go to smash by complete loss of control.

There are some automatic safety additions to the present automobile which it seems to me must come into use soon: The differential, which does not act as such until the front wheels are turned

from straightaway a definite distance; the use of a spring to keep the guide wheels straightaway until deviated by the operator's action, and then if the hand leaves the guide wheel they will return to straightaway; a convenient current cut-out which can be operated in an instant to shut off motor force.

Marshall, Minn.

A. D. HARD, M.E.

### DETAILS OF A STEEL-TIRED STEAMER.

Editor THE AUTOMOBILE:

[1,230.]—I am building a steam auto with my patent boiler, known as the Hazelton boiler. My boiler is upright, 20 inches diameter, 42 inches high. It sets either in front of the axle or behind the rear axle. The center column is 10 inches diameter, the tubes 1 by 5 inches, 600 of them. The tubes are horizontal. The water is in the tubes. Depth of water in the boiler, 2 feet. My first boiler, made twenty years ago, with ten others, sets at the foot of Thirteenth street, East River, in the New York Mutual Gas Light Co.'s works. The White steam boiler has 5,000 square inches of heating surface; my boiler has over 10,000 square inches of heating surface, and holds 100 pounds of water. I can carry 250 pounds pressure if necessary. Engines are the Mason type, made in Boston, cylinders 3 by 4 inches; wheels are 4 inches diameter, steel tires of 2-2 inches face. Front axle is a Timken roller bearing axle. My drive axle 1.5-8 inches diameter, with sleeves and four brass box bearings. Both wheels keyed on the same axle, with one sprocket and one brake. No differential gear in the center of axle. Axles are connected with reaches made of 2-2 inch angle iron. I set four full elliptic springs 44 inches long with the two bed plates bent near the ends, so they will touch near the ends before they touch in the center. This will take all jar. Body is a regular two seated carriage type, set on the springs. Wheels being 40 inches high, give plenty of space to hang boiler 24 inches below the floor line. Engines are under the floor, midway between the two axles, in a tight box, to keep dust from the chain drive. Wheelbase, 9 feet; total weight, about 1,800 pounds. The two seats are far enough apart to set two stools between them. Steel tires have been used since old King Solomon's day, and I am going to try and use them on a steam auto. They will not puncture, and will last at least ten years, and can be replaced with a new set for \$10. Locomotives and all cars have no differentials, and they go around corners nicely. The elevated roads in your city turn very short corners without any trouble, and my auto with smooth tires will go around corners without any trouble. The inside wheels on the cars and my auto must twist on the track and ground. My object in building this is to bring out a cheap auto. With this boiler I can use hard coal successfully or kerosene oil. I can run one hundred miles with one hundred pounds of coal. One pound of coal in my boiler will evaporate twelve pounds of water; one pound of kerosene will evaporate twenty-five pounds of water, and will cost four times the cost of coal. M. W. HAZELTON.  
Oneonta, N. Y.

### A FURTHER PHASE OF GYROSCOPIC ACTION.

Editor THE AUTOMOBILE:

[1,231.]—E. F. McNutt's article on gyroscopic force appearing on page 245 of "The Automobile" of February 20, calls attention to a surprising lack of judgment on the part of builders of racing cars. His statements are correct, but he overlooks one important feature which would add strength to the argument that either racing motors or race courses should be run in the opposite direction: A motor whose flywheel revolves toward the left side of the chassis produces a resultant torque tending to turn the entire chassis over in the opposite direction. This force acts in the same direction as those mentioned by Mr. McNutt, and adds to the danger of upsetting when turning to the left.

The writer would recommend changing the motors rather than the race courses, as drivers have become accustomed to turning to the left, and, as a rule, would prefer not to change, while it is as easy to make a motor run one way as the other. The ideal motor for racing purposes is one revolving in a horizontal plane (Adams-Farwell fashion). The gyroscopic force exerted by such a motor does not offer the least resistance to turning the car to either right or left, but it does exert a powerful force counteracting any tendency of the car to upset.

The resultant torque of the motor revolving in a horizontal plane does not affect the stability of the car in any way. When a gyroscope representing 4 per cent. of the total weight of a passenger car makes it possible to run on one rail, as has been done recently in England, a light racing chassis with one or two heavy motors revolving around vertical shafts certainly could take a curve at much higher speed than would be safe with other machines. The speeds of racing cars have increased in the past few years, and it is now time for those interested to consider such questions as this, which not only make higher speeds possible, but reduce the danger.

Dubuque, Ia.

GLEN MUFFLY.

## FEATURES OF RENAULT SIX-CYLINDER CHASSIS

THOUGH Louis Renault and the engineers associated with him in the production of the much-admired models of the Billancourt factory have never been enthusiastic public supporters of the six-cylinder principle, and have had sufficient success with "fours" to be satisfied with that type of engine, Renault Frères are producing a six-cylinder car for

engine, like all other models, are fitted with four rings, three on the upper part and one on the lower, this latter being designed to clear the cylinder walls of any excess of oil. It is an arrangement which has been adopted for several years to prevent the passage of oil above the cylinder heads and the consequent fouling of plugs and valves. A single cam-

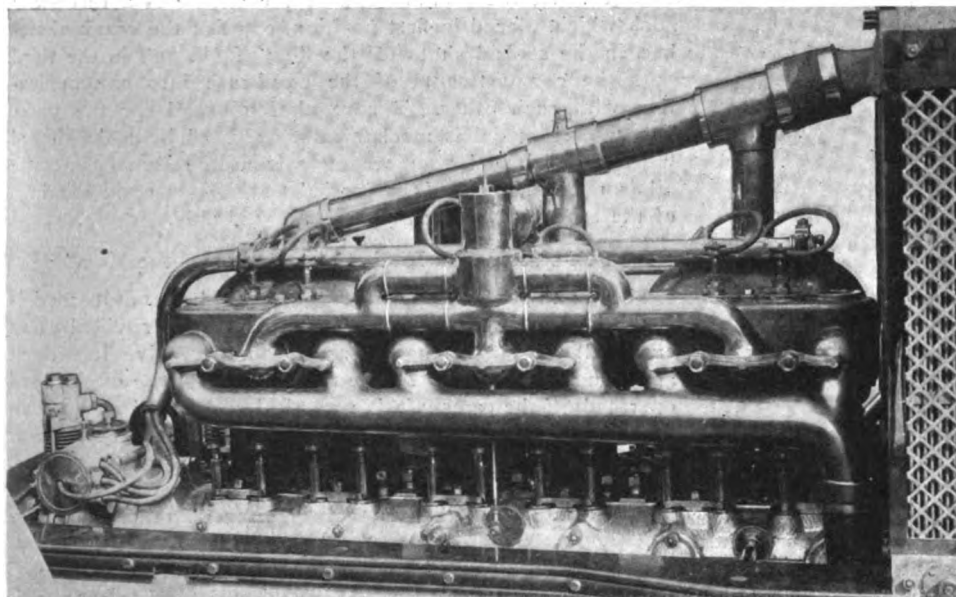

Valve Mechanism on Renault Clean-cut Accessible Six-cylinder Engine.

shaft, machined out of the solid, operates both inlet and exhaust valves on the left-hand side of the engine. To facilitate the starting of such a large engine a half compression lever, operated by a double cam has been fitted.

The arrangement of intake, exhaust and water piping, always a complicated matter on a six-cylinder engine, has been rendered more difficult on the Renault by the addition of a self-starter. A glance at the illustrations of the engine, however, shows a remarkable accessibility, and a detailed examination reveals such a disposition of the various organs as to ensure the dismounting of any part with the least amount of labor. Inlet and water piping is identical with that of the smaller engines; the use of thermo-syphon circulation, besides enabling the pump to be discarded, bringing about a simplification of piping. The efficiency of the thermo-

1908. Larger and more powerful than any of the four-cylinder models, with a wheel base of 156 inches, it forms the highest type of long-distance open or closed touring car, and is declared to be capable of a speed of 70 miles an hour with seven passengers on board.

Though an entirely new model, differing from all others in power and size, the 50-60-horsepower six-cylinder Renault is but a development of the smaller cars. Indeed, throughout the entire series, from two-cylinder taxicabs to six-cylinder touring cars, there is a remarkable uniformity of design; even the powerful racing cars of the last two or three seasons being but enlarged touring cars, differing naturally in detail, but identical in general design.

Even the engine, though composed of six cylinders instead of four, has an appearance which is thoroughly familiar to those acquainted with the other Renault models. As in the fours, the cylinders are cast in pairs, the bore and stroke being  $4\frac{3}{4}$  inches by  $5\frac{3}{4}$  inches. Normally, the engine speed is 1,400 revolutions a minute, but can be accelerated much higher without any danger of undue wear to the connecting rods and main bearings. It is hardly necessary to say that the horsepower rating is a most conservative French one.

The pistons of the six-cylinder

mo-syphon for a large engine has been amply proved by the performance of the 1906 and 1907 racers. In this connection it is interesting to recall that in 1905, when Renault experimented with force feed water circulation, all three racing cars overheated. For the first time the grilled tubes have been abandoned on all models in favor of plain vertical copper tubes connected to upper and lower receivers. This multitubular radiator was used for the first time last year

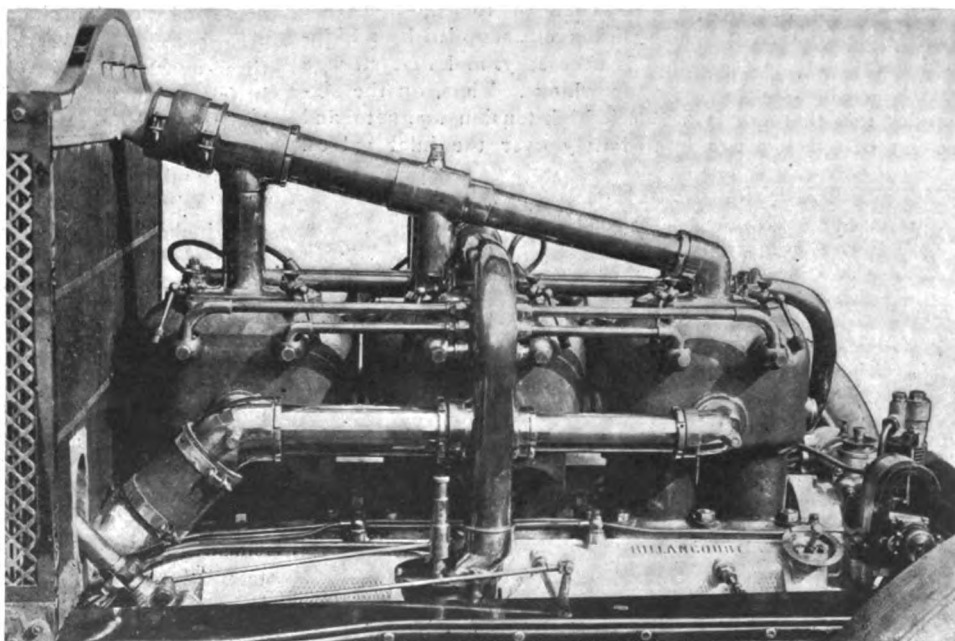

Carburetor Side of Engine, Showing Magneto and Self-starter.

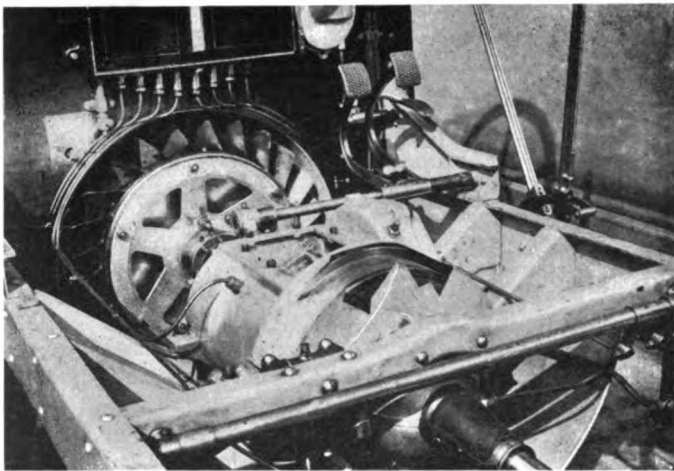

Compact Gear Set, Clutch and Fanwheel Fan.

on certain models and all racers, and gave such satisfactory results that it has been adopted exclusively. Among other advantages is the saving of weight through discarding the metal fins. On the periphery of the flywheel, just to the rear of the radiator is a sheet steel fan by which a strong current of air is always assured. One of the small refinements of this simplified cooling arrangement is the method in which the radiator is mounted on the dashboard. When the inlet and outlet pipes have been disconnected all that is necessary to dismount the radiator is the release of one nut on each side of the chassis. At the base of the radiator is a short swinging arm slotting into a bracket on the frame and held by a single nut. It is the release of this nut which allows the withdrawal of the arm and the dismounting of the radiator.

For the six-cylinder engine, the Renault automatic carbureter, with some detail refinements over previous models, is employed. It will be noted that the carbureter and the intake are at opposite sides of the engine, the inlet pipe being carried over the head of the central pair of cylinders to a mixing chamber at the opposite side, in which the gas supply is regulated. The sparking point being fixed, engine control reduces itself to the simple operation of one lever under the steering wheel, or the use of the foot accelerator.

#### How Ignition System Has Been Simplified.

Renault engineers have long been of the opinion that one reliable ignition system, with current supplied by a high-tension magneto, was all that is necessary, and that storage batteries as a stand-by were superfluous. Thus, on the six-cylinder model, there is a Bosch high-tension magneto and one set of spark plugs immediately over the inlet valves.

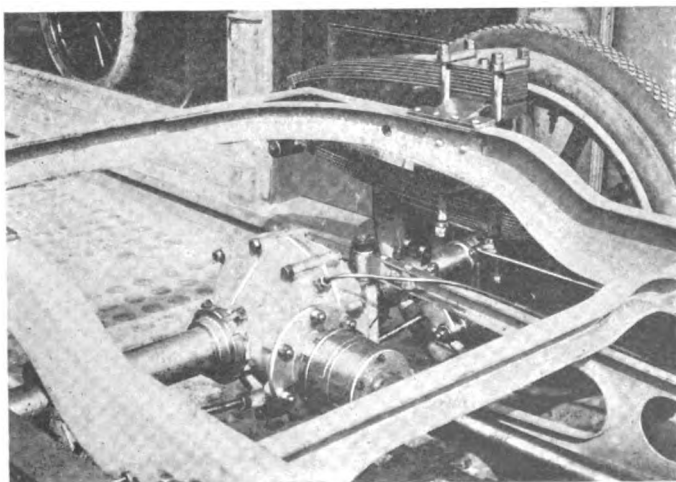

Rear Axle and Three-quarter Elliptic Springs.

The magneto, considerably smaller than those of previous years, is carried on the forward end of the engine, its revolving armature being driven by helicoidal pinions from the camshaft. The distributor is composed of a fiber cam having a brass core revolving in front of an ebonite plate holding four brushes which friction on the cam. To dismount the distributor no tool whatever is required; a half-turn of a catch and it is freed. All the wiring is carried in a metal tube running over the cylinder heads, the connection to the plugs being made by convenient ebonite discs.

In one respect only has the engine lubrication system been changed. At the forward end of the engine is a three-way cock which, placed in first position, empties the crank chamber, in the second shuts off the flow of oil, and in the third puts the compartments of the crankcase into communication with each other. The regulation of oil for the 50-60-horsepower model is mechanically operated by a dashboard lubricator driven by an eccentric from the camshaft. The oil from the sight feeds is carried to the four main bearings of the engine, the gear box and the rear axle.

#### Self-starter Is a Distinctive Feature of the "Six."

The distinctive novel feature of 1908 Renault models is the use of a self-starter. Although this is provided as an extra, all the larger engines are fitted to receive it without any structural change. At the forward end of the engine, and operated off the camshaft, is a vertical, air-cooled pump compressing air into a tank carried within the frame to the rear of the dashboard. On a pressure of 45 pounds being reached, a diaphragm acting upon the admission causes the pump to run idle. Between the air tank and the cylinders is a controlling mechanism mounted on the dashboard, and consisting, in addition to a cock opening or closing the passage of air to the cylinders, of a gauge and outlet, allowing the air to be used for the inflation of tires. A distributing drum, actuated by a hexagonal shaft driven by a helical pinion from the camshaft admits the flow of air into each cylinder through an automatic inlet valve at the commencement of the working stroke.

Clutch, gear set and transmission show few changes from previous models. The clutch is of the direct cone type, the face of the female member being cut to form tongues which aid in obtaining a progressive hold. Four speeds forward and reverse are obtained through a progressive type of sliding gear transmission, giving direct drive on the high. Final drive is by cardan shaft and rear live axle.

Suspension on the six-cylinder and all larger models is by three-quarter elliptical springs in the rear and semi-elliptics in front. In addition, the Renault hydraulic shock absorber is fitted both front and rear. For use under the rougher road conditions of America, all chassis are equipped with heavier axles and springs and are given a slightly greater clearance. The body building space on the six-cylinder model is 118 by 30¼ inches. Wheels are 935 by 135, front and rear.

#### HOFFECKER CORRECT UNDER A. C. A. TEST.

In connection with the report of the first public tests of the dynamometer installation of the Automobile Club of America, held early in January, it was reported that the Hoffecker speedometer, when tested in comparison with the speed-recording apparatus of the equipment, did not agree with the latter at the higher speeds. It appears that this was an error, due probably to the difficulty of watching both the speedometer and chart readings at the same time. The official results of the tests, made public subsequently and testified to by both President Colgate Hoyt and Dr. S. S. Wheeler, showed the Hoffecker speedometer with which Mr. Hoyt's car was equipped when under test, to have been perfectly accurate at all speeds tried, which were ten, twenty, thirty, forty and fifty miles per hour.

## AMERICA HAS AN AERO INVENTOR IN FRANCE

PARIS, March 2.—Among the small army of enthusiasts gathered in and around Paris with the intention of solving the problem of aerial navigation, America has her own representative in the person of W. H. Fauber, formerly proprietor and manager of the Fauber Manufacturing Company, Chicago and Elgin, Ill. After months of quiet experimenting, Fauber has secured from the German authorities a master patent on an aeroplane which, he believes, will cause a sensation when shown to the public. A German patent being the most difficult to obtain in the world, and only granted after thorough investigation, the mere fact that the Fauber aeroplane has been accepted is proof of its value. Before patents were granted canvas and bamboo models had to be produced and flown before the authorities.

Fauber has commenced the construction of his patented aeroplane, fitted with special pneumatic tires, and will equip it with a 24-horsepower Antoinette engine. Total weight, with the pilot aboard, will be only 510 pounds. Although he would prefer to have a 50-horsepower engine, Fauber declares that he will make attempts at flight with the smaller power as soon as possible. In his opinion the Chanute type of aeroplane as used by Farman is fundamentally wrong and, though successful for short distances, will never be of much practical value. An aeroplane built under the Fauber patent will be as self-balancing as a boat, and will allow the pilot to rise to any height with safety. Should the motor stop or the steering gear become disarranged, the machine would still descend safely. Unless completely wrecked by a storm, the aeroplane would always allow its pilot to gradually come to earth after an accident to the machinery.

Had he not been fully occupied with practical hydroplane experiments, Fauber declares that he would have trained and competed for the \$50,000 aeroplane prize recently won by Farman. He had to be content, however, to first secure patents on his flying machine before making it public. Mak-

ing allowance for changes which will necessarily have to be made in the model as suggested by experience, the American aeronaut believes that he will show very practical results before the end of the year. Outside experiments with the flyer will commence shortly and continue throughout the year.

At the present time Fauber is busy on two distinct types of hydroplanes, one with a screw, the other with a paddle. The latter has reached its fourteenth experimental trip, and though not yet quite satisfactory, promises to give good results. A paddle hydroplane, says Fauber, is generally treated as a joke, but this type will prove itself superior to the screw and will prove applicable to large steamers.

The screw propeller hydroplane on which Fauber is engaged is so far advanced that he hopes to be able to build a number of them in the spring, and, if possible, will enter a racing model in the Monaco meet, April 1 to 13. This boat is a combination between a hydroplane and a displacement boat, the bottom being of a special shape and designed to navigate in rough water. It has the appearance of an ordinary boat, but is much more stable and is self-balancing. An 80-horsepower eight-cylinder Antoinette engine without carbureter, the gasoline being injected direct into the cylinders, is employed. These engines are always difficult to start, but when they do get under way they go off like a cannon ball. On the first trial Fauber's superintendent was thrown right over the engine, fortunately without injury, and on the second trial trip the motor started with a rush and snapped off three of the blades of the propeller. Although the propeller was made specially for this work by the Antoinette people, it was not sufficiently strong to stand the enormous strain put upon it by the instantaneous starting of such a powerful motor. This is a difficulty other aeroplane and hydroplane experimenters have had to contend with, and it will be necessary to pay special attention to the study of propellers for use with the eight-cylinder engines.

### BIG WAR DIRIGIBLE FOR FRENCH ARMY.

PARIS, March 2.—The French Army has made arrangements with the Lebaudy Brothers and Engineer Julliot for the construction of a dirigible balloon for military purposes of 380 feet in length and of a capacity of 290,000 cubic feet. The gas bag will be made of rubbered cloth of sufficient strength to withstand a considerable increase in internal pressure, and as in all the French military balloons, an internal ballonnet fed by a powerful fan will maintain the desired pressure.

In general the characteristics of the *Patrie* and *Lebaudy* will be followed in the platform design. The power plant, however, will be entirely original. Two Panhard motors, each of 120-horsepower, will drive four propellers, two forward and two aft. The engines decided upon are those used in the *Panhard-Tellier* racing motor boat, the fastest craft of its size ever built in France. The weight of each of the four-cylinder motors is 617 pounds. In the motor boat the two engines were placed side by side. Very probably this arrangement will be preserved in the airship, the entire engine platform of the boat being transferred to the war balloon. One reason for fitting two independent engines is to prevent a repetition of the accident of the *Patrie*, where, owing to the breaking of a gear both ignition systems were disabled. It is estimated that a speed of 40 miles an hour will be attainable under ordinary conditions. The *Patrie*, which at the time of its evasion was the largest military airship in commission, was 203 feet in length and equipped with a 70-horsepower four-cylinder Panhard racing motor.

### FIRST AERO SCHOOL IS ESTABLISHED.

Without doubt the latest field of knowledge to be entered by the correspondence school is that of aeronautics, which has its first academy in the International School of Aeronautics, recently founded by Albert C. Triaca, at 108 West Forty-ninth street, New York City. Three distinct courses are outlined in the prospectus, covering respectively spherical balloons, dirigibles, and aeroplanes. Recently returned from Europe, where he obtained the diploma of pilot from the Aero Club of France, Albert C. Triaca has gathered together an unusually complete series of models of balloons, aeroplanes, aeronautical engines and all accessories. Connected with the staff are many European experts.

### MICHELIN OFFERS \$43,000 FOR AERO RACES.

PARIS, March 2.—A world's challenge cup valued at \$20,000, in addition to \$3,000 in cash, have been offered by M. Michelin for an annual aeroplane race. Though no distance has yet been announced for the first year, it is stated that each year the contest must be held over a distance double that of the preceding year. The trophy will be held by the aero club of the country of which the winner is a native.

In addition to the annual challenge, M. Michelin also offers a prize of \$20,000 to the aeronaut who first travels from Paris to the Puy-du-Dome, a distance of 250 miles, in a heavier-than-air machine. The challenge remains open until 1918. The Michelin factory is located at Clermont-Ferrand, at the foot of the Puy-du-Dome.



## SPENT ON FOREIGN AUTOS.

Americans have spent \$31,728,981 on foreign automobiles during the past six years, \$10,576,327 of this amount representing import duty and freight. Excluding taxicabs, auto 'buses and one amphibious automobile which visited these shores, European makers sent 1,300 automobiles to America during the past twelve months, 225 being from one company, 214 from another, and 139 from a third, leaving 722 cars for 45 different makes, or an average of 16 cars apiece. A comparison with the amount done by American manufacturers for the last five years shows enormous strides. In 1903 the American output was \$16,000,000; 1904, \$24,500,000; 1905, \$42,000,000; 1906, \$59,000,000; 1907 (A. L. A. M. estimate), \$105,669,572. This shows that while foreign cars have increased in numbers yearly from 1902 to 1907, the increase is slight compared with the enormous growth of the home industry; even 1907, admittedly a poor year, having a large increase.

Last year there was a falling off in imported automobiles to the extent of 133, representing a value of \$2,569,141. The banner year for the foreigner was 1906, when 1,054 cars were imported at a value of \$3,972,298. Import figures from 1902 to 1907 are as follows:

Year.	No. of cars.	Value.
1902.....	265.....	\$3,581,990
1903.....	267.....	2,927,508
1904.....	605.....	2,240,000
1905.....	1,040.....	3,972,298
1906.....	1,433.....	5,500,000
1907.....	1,017.....	2,930,859

In addition 283 used and second-hand automobiles, on which no duty was paid, and 231 taxicabs and 10 'buses, on which duty was paid, were brought into the United States during 1907. The total of all foreign motor vehicles is therefore 1,541.



What the Cab Business is Coming To.

Scene outside a London restaurant. Hall porter emerges and blows his whistle vigorously. With the first and second blasts a "growler" and hansom dash up to the kerb, but the porter sounds the whistle a third time, the signal for a taxicab. Disgusted Cabby: "Try four, Old Sport, and p'raps you'll git a bloomin' airy-plane."—"The Car."

## THE AUTOMOBILE CALENDAR. AMERICAN.

### Shows and Meetings.

- Mar. 18-21.....—Rochester, N. Y., New Convention Hall, First Annual Show, Automobile Dealers' Association and Rochester Automobile Club. Bert Van Tuyl, manager.
- Mar. 18-24.....—New Haven, Conn., Mulc Hall, Annual Show, New Haven Automobile Dealers' Association.
- Mar. 21-28.....—Toronto, Canada, St. Lawrence Arena, Automobile Show. R. M. Jaffray, manager.
- Mar. 23-28.....—Indianapolis, Ind., Annual Show, Automobile Dealers' Association.
- Apr. 4-11.....—Pittsburgh, Pa., Duquesne Garden, Annual Show, Automobile Clubs of Pittsburgh. Thomas I Cochran, manager.
- Apr. 5-12.....—Montreal, Canada, Arena, Third Annual Automobile and Sportsman's Show. R. M. Jaffray, Mgr.
- April 6-8.....—Denver, Mammoth Rink, Annual Automobile Show. G. A. Wahlgreen, manager.

### Race Meets, Hill Climbs, Etc.

- Mar. 18-19.....—Savannah, Ga., Savannah Automobile Club.
- April 6-10.....—New York City, Automobile Carnival, Illuminated Parade, Hill Climb, etc., New York Automobile Trade Association.
- April 24.....—Briarcliff Trophy Race, Westchester County, N. Y. Robert L. Morrell, chairman.
- May 4-5.....—Harrisburg-Philadelphia and Return, 150-mile Endurance Run, Motor Club of Harrisburg.
- May 15.....—Chicago, Algonquin Hill Climb, Chicago Motor Club.
- May 16.....—Hartford, Conn., 200-mile Endurance Run, Automobile Club of Hartford.
- May 30.....—Bridgeport, Conn., Sport Hill Climb, Bridgeport Automobile Club.
- June 24-27.....—Chicago, 1,200-mile Reliability Run, Chicago Motor Club.
- July 6-8.....—Buffalo, National Convention of the A. A. A., and Start of Fifth Annual Tour.
- Sept. 14.....—Chicago, Annual Economy Run, Chicago Motor Club.

## FOREIGN.

### Shows.

- Mar. 21-28.....—London, Agricultural Hall, Cordingley's Show.
- Mar. 28-April 6.....—Paris, Alcazar d'Ete, Small Inventors' Exhibition.
- Mar. 26-April 4.....—London, Olympia Industrial Vehicle and Motor Boat Show.
- May 17-June 2.....—Moscow, Russia, International Automobile Exposition, Automobile Club of Moscow.
- December.....—Paris, Eleventh Annual Salon de l'Automobile, Grand Palais, Automobile Club of France.

### Race Meets, Hill Climbs, Etc.

- April 1-13.....—Monaco Motor Boat Races and Motor Boat Exhibition, International Sporting Club of Monaco.
- April 25-May 25.....—Industrial Vehicle Competition, Automobile Club of France.
- May.....—Paris, Competition for Agricultural Automobiles, auspices of "L'Auto." (Date to be announced.)
- May 1-31.....—Automobile Taxicab Competition, France, Automobile Club of France.
- May 10.....—Sicily, Targa Florio, Automobile Club of Italy.
- May 31.....—Russia, St. Petersburg to Moscow Race.
- June 1-18.....—Reliability Trials for Pleasure Cars, Automobile Club of Great Britain.
- June 9-17.....—Touring Competition for the Prince Henry of Prussia Prize, Germany, Imperial Automobile Club of Germany.
- July 6.....—Voiturette Grand Prix, Dieppe Circuit (Automobile Club of France).
- July 7.....—Grand Prix of Automobile Club of France, Dieppe Circuit.
- July 13-17.....—Ostend, Belgium, International Race Week, Automobile Club of Ostend.
- July 20-30.....—Ardennes Circuit Races and Coupe de Liedekerke, Automobile Club of Belgium.
- Aug.....—France, Coupe de la Presse, Automobile Club of France. (Exact date to be announced.)
- Aug. 29-30.....—France, Mont Ventoux Hill Climb, Vauclusien Automobile Club.
- Sept. 1-8.....—French Voiturette Contest, auspices of "L'Auto."
- Oct. 11.....—Berlin, Germany, Gordon Bennett Balloon Race, Aeronautical Club of Berlin.

## WHAT EUROPE IS BUILDING FOR THE GRAND PRIX

PARIS, March 3.—From what can be learned around the factories, the racers now being built for the French Grand Prix will have a stroke varying from 6.6 inches to 7.08 inches, this latter being regarded as the practical limit for an engine with a bore of 6.1 inches. Panhard, whose three engines are now ready, has adopted the smaller bore of 6.6 inches, for the four-cylinder motors, the horsepower of which is given as 125. Separate steel cylinders with copper water jackets are employed, symmetric valves being on opposite sides. In other engine features the racers follow touring-car models, with Krebs carbureter having hydraulic regulator, centrifugal water pump, honeycomb radiator and disc clutch.

For the first time since 1904, Panhard racers will have chain drive. For the last three years Panhard has built all touring cars with side chains and all racers with shaft drive. This year racers and touring cars will be identical in this respect. The tendency to reduce both wheelbase and track is clearly shown in the Panhard racers, the former being but 104 inches and the latter 51 inches.

Germain, the only Belgian contestant, will, like Panhard, have a full team of four-cylinder cars, with separate steel cylinders copper jacketed. The bore is the maximum, and stroke is declared to be 175 millimeters. Bosch high-tension magneto has been fitted, and engine cooling is effected by means of a centrifugal pump and honeycomb radiator.

Weigel, the only Englishman who competed in last year's race, and received little for his pains beyond interviews with the police, has three interesting chassis under construction for the Dieppe race next July. The four cylinders are in one casting, with valves at an angle of 45 degrees at each side of the domed head. Cylinder bore has been fixed at 154.5 millimeters, half a millimeter being sacrificed in order that there may be no possibility of objection. The stroke is being kept secret, and will not be announced until a few days before the race. The valves, which have a face measurement of no less than 75 millimeters, are so inserted in the cylinders as to decrease pocket area to the uttermost. The exhaust valve is water-cooled round the guide and valve seating, both being part of the cylinder proper. The camshaft, with integral cams, runs in three ball bearings carried in standards cast on top of the cylinders. It is operated at the radiator end by a worm gear and vertical shaft. Wheelbase is 110 inches, transmission is through selective sliding gear, and final drive through rear live axle. The cars are exceptionally low.

Though Edge, of Napier interests, will not appear in the Grand Prix, his cars not being fast enough without forbidden detachable wheels, England will have a six-cylinder representative in the Austin firm. Four cars have been built, all with five-inch bore and stroke, two of them having side chains and two live axle drive. The faster pair will race.

## ROYAL CLUB AND UNION STRIVE FOR POWER

LONDON, March 3.—Though the oblique branch is held out by a section of the British automobile clubs, prospects of an entente between the Royal Automobile Club and the Motor Union, principals in the fight for automobile supremacy in Britain, are not promising. The old-established, dignified and royal club is not likely to make any concessions in national control, and the youthful Motor Union, having realized its strength in the struggle, will not be satisfied until it has a real domination in the automobile affairs of the country.

The entire question revolves around the decisions of the provincial clubs, and the body which can secure the larger affiliation will be the one that will have to be reckoned with as master of British automobile organizations. The Royal Club claims that 12 clubs, with an aggregate membership of 3,113, have decided to remain true to them, while 14 clubs, uniting 1,580 members, will affiliate with the Motor Union. Those having decided to remain affiliated with both Royal Club and Union during 1908 comprise 21 provincial clubs, with a membership of 2,482.

This would appear to give the Royal Club a distinct ma-

majority. Closer examination of the two lists, however, fails to substantiate the first impression, the Scottish and Irish clubs, numerically the strongest in the United Kingdom, being the two which have least need of the Piccadilly club. The probabilities are strongly in favor of the Motor Union already having the larger following, and when the twenty-one clubs have got off the fence there is no doubt whatever as to which body will have a majority.

Could some understanding be arrived at immediately the best interests of the automobile clubs would have been served, for the Englishman, despite his inherent respect for established authority, has shown that he has little need for a mummified controlling body, though it may have the King at its head, the right to use the word "Royal," headquarters in Piccadilly, and a train of aristocratic connections. The struggle has quickened the flow of the royal blood and has made the august body more active, more efficient, than at any previous period. It has not diminished the ardor of the Youthful Motor Union, but it has given that organization a more redoubtable adversary. Unfortunately automobile legislation is neglected as the result of the split.

## INTERNATIONAL ROAD CONGRESS IN OCTOBER

PARIS, March 3.—October 11 and seven following days have been selected as the date of the international road conference to which the French government will invite representatives from all nations of the world. The program of the conference, which is due to the initiative of Minister of Public Works Barthou, is the improvement of roads to fit them for modern methods of locomotion. Two main sections have been formed, the first to deal with road construction and upkeep and the second with traffic regulation and road exploitation under the new era introduced by the auto-

During the week of the congress a public exhibition will be held at the Jeu de Paume in the Tuileries Garden, dealing with methods of road construction, tools and machinery for road building and the suppression of dust, models of vehicles and their influence on road surfaces, sign posts, danger indicators, etc. Models intended for the public exhibition should be addressed to the Secretary of the First International Road Congress, Ministry of Public Works, 24, Boulevard Saint-Germain, Paris. Donatory membership can be obtained on payment of \$20; subscribing members pay \$4.

# THE AUTOMOBILE

Vol. XVIII Thursday, March 12, 1908 No. 11

## THE CLASS JOURNAL COMPANY

Flatiron Building, Madison Square  
New York City

H. M. SWETLAND, President

### EDITORIAL DEPARTMENT

A. G. BATCHELDER, Managing Editor

R. F. KELSEY, Associate Editor C. B. HAYWARD, Engineering Editor

W. F. BRADLEY

### BUSINESS DEPARTMENT

A. B. SWETLAND, Business Manager

LOUIS R. SMITH FRANK B. BARNETT

W. I. RALPH, 1035 Old South Building, Boston, Mass.

C. H. GURNETT, H. E. WESTERDALE, 836 Monadnock Block, Chicago, Ill.

Cable Address - - - - - Autoland, New York  
Long Distance Telephone - - - - - 300 Gramercy, New York

### SUBSCRIPTION RATES:

United States and Mexico - - - - - One Year, \$3.00  
Other Countries in Postal Union, including Canada - - - - - One Year, 5.00  
To Subscribers—Do not send money by ordinary mail. Remit by Draft,  
Post-Office or Express Money Order, or Register your letter.

### FOREIGN SUBSCRIPTION AGENTS:

ENGLAND:—Illiffe & Sons, Limited, 29 Tudor Street, London, E. C.  
FRANCE:—Boyveau & Chevillet, 22 Rue de la Banque, Paris.  
GERMANY:—A. Seydel Mohrenstrasse 9, Berlin.

Entered at New York, N. Y., as second-class matter.  
The Automobile is a consolidation of The Automobile (monthly) and the Motor  
Review (weekly), May, 1902, Dealer and Repairman (monthly), October, 1903,  
and the Automobile Magazine (monthly), July, 1907.

Copies printed in 1905	- - - - -	730,000
" " in 1906	- - - - -	791,000
" " in 1907	- - - - -	888,000

## THE WAY OF A POLITICIAN.

Something out of the usual was the visit of State Senator Frelinghuysen to the New Jersey Automobile and Motor Club for the purpose of "discussing" the proposed amendments to the law which hampers the enjoyment of automobiling in a commonwealth where legislators early recognized the value of good roads. One must admire the sagacity of the Senator in accepting the invitation to meet Jersey autoists last Friday night at Newark, but those present soon learned that all politicians are more or less alike in their methods. The man from Somerset County said that he had come to "learn the views" of the autoists, and, furthermore, he was in a "receptive mood." No, he was not prepared to state positively what action he might take upon certain proposals; he would take them "under consideration."

But one should not blame a man who has an eye out for a governorship because he takes inventory of what he has and then seeks information first hand as to the growing strength of those holding ideas contrary to opinions obstinately hugged by his assured constituency. And the Senator found that there is now an organized and determined opposition to further complacent acceptance of automobile legislation which is based on prejudice and with scant desire to grant fair treatment to the new users of the road.

It is among the possibilities that Senator Frelinghuysen may have accumulated more of a reputation as an anti-automobile autoist—for he is a car owner—than he

really intended, and, in looking after the main gubernatorial chance, he may desire to show that he himself is not inclined to be pronouncedly antagonistic to the law-abiding autoist—providing that same autoist is there with the votes. As a matter of fact there is ground for belief that the Senator is the victim of his Somerset supporters, and is really in a deuce of a fix as to how he can extricate himself gracefully and without loss of prestige. Truly, the position of the politician is such as to entitle him to sympathy rather than unlimited condemnation.

We are told by the Senator that conditions are so peculiar in New Jersey that reciprocal recognition of the licenses of other States is impracticable—for the outlanders wear out the roads, disregard the rights of other users of the highways, and commit other crimes. Elsewhere in this country it is possible to punish outlanders when they are guilty of infractions of the autoing law, even when they only carry the registration numbers of their home States; it is also computed that they frequently leave behind enough money to offset any wear of the roads resulting from their passage. But "conditions" in Jersey prevent similar procedure; therefore, the outlanders are remaining outside of the "Chinese wall" in greatly increasing numbers. Roads do not "wear out" in Jersey as in other States; automobiles "destroy" them; therefore, automobilists ought to pay liberally for the "damage" which they wilfully accomplish.

But there is a limit in suffering injustice because a sane law does not replace an obnoxious statute which exists apparently because the machinery of justice cannot be operated—in New Jersey—in such manner as to punish the guilty without hampering the innocent and making his pursuit of autoing subject to interruption and oppression.

The need of local, State, and National organization in automobiling is emphasized in the New Jersey situation. Its ultimate outcome is a certainty.

The visit of the worthy Senator will bear fruit when another crop of legislation is picked.



## SHORTENING THE MOTOR'S LIFE.

There are two practices, more or less commonly followed by the average owner or driver of a car, that do more to shorten the period of an automobile motor's active life and cause more damage than would be occasioned by many times their equivalent of legitimate service. One of these is racing the motor idle, and the other is the habit of worrying it over grades on the direct drive. Both show a lack of common sense on the part of the drivers practicing them and are far too generally followed, from which it seems that a little technical knowledge bearing on this point would be an aid in keeping many a car out of the repair shop. Of the two, the first is much more common—in fact, it is almost universal, and is the more difficult to overcome, as it does not produce any apparent bad effect at the time, whereas forcing a motor on hills is apt to stall it and this is regarded as a sign of bungling. But both contribute to place the car in the shop far more often than would be the case with more reasonable handling.

## LEWIS F. NIXON ON AUTOMOBILE'S GREAT FUTURE

**S**T. GEORGE, N. Y., March 7.—The annual dinner of the Richmond County Automobile Club, the most successful in the history of the organization, was held at Tilley's Hotel, with Lewis Nixon as the principal speaker of the occasion. His somewhat impromptu address was intensely interesting and listened to with closest attention. It will be remembered that Mr. Nixon was one of the pioneer designers of automobile engines, but the demands upon his time in other affairs took him out of an industry in the future of which, judging from his remarks, he has unlimited confidence.

President Charles A. Schultz presided as toastmaster, and besides Mr. Nixon, the speakers included John T. Burke, managing editor of the *New York Evening Telegram*; Coroner A. F. Schwannecke, who strongly advised automobilists not to run away from any accidents in which they might become involved; Thomas F. Moore, secretary of the Briarcliff race, who supplied the humor of the occasion; H. E. Buel, who talked upon the boulevard across Staten Island; and A. G. Batchelder, editor of *THE AUTOMOBILE*, who dwelt upon the needs of organization for the purpose of safeguarding the rights of automobilists.

At or near the head table sat Vice-President George H. Waters, J. J. Worrell, the indefatigable secretary, and the entertainment trio, consisting of E. H. Poehn, W. O. Sprigg, and Dr. W. J. Musgrove.

The speech of Mr. Nixon will be read with interest by automobilists in general, and it is herewith given nearly in full:

As to the future of the automobile, probably we can best speak of that by looking at what has been done in the last few years. Probably nothing has been done by mankind in the mechanical world which compares at all with the automobile. It is probably the modern miracle—certainly the one of the century. We now feel that we can travel an ordinary highway with the safety of the railroad train, and with even as much comfort. We feel that it is dependable; we feel that mankind has accomplished a thing in a way which it always does when the mind of man is put to it.

The automobile is, of course, new. In 1900 there were but 3,700 in the United States. In 1904, Americans built over 11,000, and last year over 52,000. There are to-day in this country 152,000 automobile owners. These machines cost to run not less than \$75,000,000 per year, and the actual value of them is \$270,000,000. All business in the country has been stimulated by this industry. Not only that, but the most encouraging thing is that while a few years ago we were obliged to go abroad for our cars, to-day we find ourselves in this country exporting large numbers of cars of every description to other countries.

We know that the American always will develop the very best when he has the opportunity. We all know that years ago the man who worked in the bottom of the ship or in the factory—the man in the overalls—was looked down upon. But to-day we find an entire change, and men who do not have to do that kind of work will go at their automobiles and get themselves well smeared with grease, and are proud of the fact that they have a mechanical knowledge sufficient to enable them to do their own repairing. And this fact is increasing a feeling of respect for the mechanic, and, perhaps, there is nothing that we can bring about in this country that will operate to the advantage of the country more than this feeling, joined with an appreciation of what the mechanic and the engineer are doing for the benefit of the world, and the improvement of all mankind's condition.

Now, it is very hard to forecast the development of an industry and of an art which is increasing by such leaps and bounds the way automobilism is. But we have yet to see the time when the car will be the accompaniment of every home, when people will see that they must have them the same as they have the horse and buggy. Of course, we must always have the horse and buggy. I was looking in an automobile paper to-day, and I saw a description of an automobile buggy, and I thought as I read it: "The world has come into its own; here we have a buggy which can with safety run 30 miles an hour, that will cost \$250, and that will probably compare very well with the old buggy, and with less expenditure for running than with a horse."

There has been a time in the last few years when the joke against the automobile on the stage would bring down the house. And we all laughed. But I tell you to-day that it is to be depended upon. We have accidents that occur through carelessness and ignorance and inefficiency in management, but as a matter of gen-

eral interest we can say that the automobile is now rapidly approaching a perfected state. Then, of course, we find those who are always looking for trouble, and they say that the automobile is affecting the farmer. I don't think so. Ten years ago there were about 14,000,000 horses in the United States of the average value of \$30 each, while to-day there are 20,000,000 horses in the United States of an average value of \$93 each; in other words, an increase in value in ten years of a little over \$30 to \$90 per horse; so I don't think the farmer has shared very badly in increasing a value of \$450,000,000 to \$1,800,000,000 in ten years. I won't say the automobile has done it, but it has driven people to buy the very best of horses.

The use of the automobile at the beginning was naturally more for pleasure, but its rapid increase for business purposes can plainly be seen. Colonel Waring, who was superintendent of the Street Cleaning Department of New York City, told me that there were each day 500 tons of horse droppings in the city of New York alone, and he said that he hoped to see the day when the automobile would supersede the horse in the streets of the city. That was a good many years ago, but it is rapidly approaching, and the trucking that is now being done by auto trucks is enormous. Undoubtedly before very long you will not see a horse in the city of New York. The increase in the health of the city when it comes about will be enormous, and I do not think it will affect the earning capacity of the men who are experienced in loading and handling the present trucks. The automobile's use by big department stores is enormous, as you know, and I think the ultimate result will be that they will have bodies which will be made separate from the chassis, and which, after being loaded, can be placed upon the chassis quickly, and when they come back the empty body will be replaced by another which has been loaded in the meantime, thus decreasing the cost of handling and keeping the apparatus always on the go, which is the aim of all business economy.

The luxurious car will always be in demand. Then again we have the car which will be built and sold at a cost to meet the pocket of the average man, and which will cost little to repair and to operate. In this respect our lawmakers do not seem to rise to the occasion, and realize that we are rapidly increasing the price of gasoline, which seems to be the only present commodity we can use for fuel.

In fuel we must face a scarcity in gasoline and a rapid advance in price. But there is one inexhaustible source uncontrolled by owners of mines or corporations. That is alcohol. Anything that will ferment will make alcohol. The grain, rotten apples, pumpkins, grapes and other products of the farm will go into tanks and the farmer will produce a fermented liquid that can be refined at central stations into high-grade alcohol. The law regulating the production of alcohol was not intended to make it commercially obtainable. In Cuba alcohol can be bought for 10 cents a gallon. The people will ultimately wake up and demand proper legislation, and it is not a far stretch of the imagination to see us light our houses, heat our dwellings, cook our food and run our cars and factories by alcohol produced by the American farmer.

Where we are tied down by rail you will find that the automobile car is coming into rapid use. They are building cars to-day about 65 feet long which will easily make sixty miles an hour and which are fitted up with all the various comforts that go with the steam car. They will come into use more and more. We expect it.

When we look into the future and stimulate our imagination, we can see that the needs of the people will bring about an aerial system of transportation. We know that the aeroplane will be used, and we shall then be able to get to Philadelphia at a rate of 160 or 170 miles an hour, traction being by some special method.

The development in war is another feature of the automobile. The flying machine which leaves the earth we can look forward to seeing. It is the necessity of modern civilization, and it will be used in the next war undoubtedly. But we have torpedoes that we use under the water, and we will also undoubtedly have land torpedoes. These will be in the shape of the original automobiles, and these will be filled with high explosives and controlled by paid-out wires or wireless.

All these things are only some of the little forecasts that are to be seen at the present time as the future of the automobile. The greatest good to the people comes by our getting all we can out of our lives, and that is naturally to our advantage. I have no doubt but that the men of the present day do more work than in the past; they get over a great deal more ground and accomplish a great deal more.

Many devices having to do with automobile construction are being radically improved or bettered. Carbureters and tires are receiving the attention of the inventive minds and appliances for lessening the danger of accidents of all kinds are of almost daily birth.

Then, again, as to the roads. We still have the bogs and mires



between small towns, but, I think, as our needs in this direction grow, we shall have all of these communities joined by very wide roads, which by means of short-time franchises will warrant those holding such franchises constructing substantial roadbeds, certain parts of which will be limited to automobile traffic. I think the people will take the initiative and give us the blessing that good roads will give us. I believe that the enterprise and the public devotions of the officers of this borough of Richmond have built up the highest state of roads I have ever seen. I do not believe you can ride over any other roads with more pleasure than you can on the roads of Staten Island. Take, for instance, the idea of a boulevard to Tottenville from the ferry. You will find that such a run would attract the automobiles from all over.

And that brings me to what I want to say particularly, and that

is, I want to ask every one to appreciate what has been done by this club, and by the president and secretary of it, Mr. Schultz and Mr. Worrell. They have been whole-hearted and devoted to the interests of the club and the safety of automobilists in general, and I believe that the time will come when we will see an automobile clubhouse on Staten Island. I am sure that the island will grow—it is growing—and as the automobile will become more and more part of our life we shall find the needs of a clubhouse with a garage. We shall see that the automobilists will awake to the occasion and realize that it is incumbent upon them to support the club in every way possible, and that its ambition will be realized, and we shall have on this beautiful Staten Island not only an automobile club, but an automobile clubhouse, with Mr. Schultz as permanent president of it.

## NEW JERSEY'S LAW "DISCUSSED" WITH SEN. FRELINGHUYSEN

NEWARK N. J., March 9—The automobilists of New Jersey are still discussing the visit of Senator Frelinghuysen to the New Jersey Automobile and Motor Club on Friday night of last week. This wide-awake organization invited the Senator from Somerset county to attend an open session at its clubhouse, to which were also bidden delegates from other Jersey clubs. The club's quarters on Broad street were packed to suffocation and both the present law and the proposed amendments to it received vigorous attention all around. Ultimately those present took action as outlined in the resolutions herewith given:

**Resolved,** That this club is in favor of a law which will require that every vehicle using the highway shall carry a light at night, and pledge ourselves to support such a bill by endeavoring to secure the support of our Representatives and Senators to that end.

**Resolved,** That this club is in favor of the amendments as presented by Senator Frelinghuysen to the crimes act in reference to placing glass or other hard substances upon the highways, and refunds to the State of fines inflicted by local justices.

**Resolved,** That this club is in favor of a tourist privilege to be extended free to non-resident tourists, provided they are duly licensed in their home State and carry sufficient identification tags to insure compliance with the laws of the State of New Jersey.

**Resolved,** That this club is irrevocably opposed to the license fee proposed to be assessed against the automobilists and dealers of this State, and unless a fair and equitable schedule be substituted therefor, this club is authorized to contribute its proportion to the general fund for testing the constitutionality of a law which permits high and prohibitive double taxation under the cloak of license or registration fees.

**Resolved,** That it is the sense of this meeting that licenses being granted in perpetuity to manufacturers or dealers in automobiles, as provided for in Part IV., par. 16, sub-division 3 of the present automobile law, no other law can be enacted or tax levied for the purposes as outlined in said law, and any effort on the part of members of the Legislature to annul this provision will be vigorously opposed.

**Resolved,** That it is the sense of this meeting that the department of motor vehicle registration and regulation shall remain under the jurisdiction of the Assistant Secretary of State, as at present provided.

**Resolved,** That this club is in favor of a reasonable and safe speed limit consistent with the circumstances, and which will fix the maximum speed at not greater than thirty miles an hour, such provision to be drawn in such a way as will provide for the safe use of the highway by all, and which will command the respect of every user of the highway.

**Resolved,** That if the present amendment be not so amended as to secure to the automobilists of this State reasonable and fair treatment, the legislative committee of this club be authorized and empowered—in conjunction with the other clubs of this State—to prepare and present for passage a fair and reasonable automobile bill based on common sense and the lines as have been adopted in many of our sister States.

**Resolved,** That a vote of thanks be extended to Senator Frelinghuysen for his courtesy in attending this meeting and for the frankness with which he has expressed himself in reference to the subjects under discussion, and that the secretary be instructed to transmit to Senator Frelinghuysen copies of the resolutions adopted at this meeting, with a request that he endeavor to have the present automobile law amended so as to meet with the approval of the automobilists of this State.

It will be seen by the reading of the resolutions adopted that the automobilists and Senator Frelinghuysen are at a considerable distance from each other in reaching an agreement. The

discussion made plainly evident the fact that the Senator has political aspirations which may have a bearing upon his automobile law-making, though he took occasion to repeat several times that politics did not enter into the matter in the slightest degree.

There was some other plain speaking by George A. Post, of the North Jersey Automobile Club, who said that he intended to offer a reward for the arrest of Senator Frelinghuysen for violation of the speed limit of the present law. Dr. J. N. Faulkner, also of the Paterson club, asked the Senator if he had ever violated the 20-mile speed ordinance.

"I might ask the doctor the same question," responded the Senator.

"Answer mine first," retorted the physician.

"Never willfully, and not knowingly," was the answer from the Senator, which was greeted with laughter. Dr. Faulkner's only answer was that he had heard that the father of the automobile law traveled faster than twenty miles an hour every time he went out in his car. "He ought to know by this time," said the doctor, "that it would be impossible to keep within the limits."

The autoists argued that the speed law was openly violated, and they openly admitted that they all violated it repeatedly when they operated cars that could travel at a fair rate of speed. Joseph H. Wood, who introduced the resolution providing for an increase in the speed limit, admitted that he was a law-breaker, and produced a record of his runs through the city at an average speed of from ten to sixteen miles an hour and from eighteen to twenty-six miles in the country. Mr. Wood said that he has never been arrested, and although he had traveled as much as 35,000 miles, he had done no damage. He said that it was impossible to maintain an average speed of twenty miles, and every operator of an automobile, not even barring Senator Frelinghuysen himself, was a law-breaker. Mr. Wood said that the New Jersey automobilist has practically been crucified upon the cross of political ambition of a few legislators.

Richard C. Jenkinson stated that the Newark Board of Trade was interested in the question from an industrial standpoint, and said that the automobile industry was of vital importance to the city and State from the fact that every part of a motor car was manufactured here and that thousands of people were kept employed.

President Mason, of the Passaic Board of Trade, was another who struck the bull's eye many times, according to those present. A. G. Batchelder, who recently became a Jerseyman, illustrated the attitude of non-resident autoists toward the State on account of its unfair law.

Senator Frelinghuysen defended the present statute and its non-reciprocal license feature, and otherwise spoke favorably of it. He said he would take "under consideration" the various things suggested, and asked for a copy of the minutes of the discussion, so that he could "confer" with his associates in the legislature. The opinion of the automobilists generally is that the day for conferring is past, and it is among the probabilities that if necessary the war will be carried into Somerset county.

## VIRGINIA AND CAROLINA AUTOISTS AFTER GOOD ROADS

BY F. S. SLY, TRAVELING CORRESPONDENT OF THE AUTOMOBILE.

**N**ORFOLK, VA., March 4.—Considerable activity is being displayed by the Norfolk Automobile Club in the agitation for good roads, particular attention being paid at the present time to securing a good road between Richmond and Norfolk and between Norfolk and Virginia Beach. A bill is now before the State Legislature providing for the appropriation of \$250,000 for State aid in road building.

The Norfolk Club, with a membership of fifty, has opened a campaign for new members. The officers of the club are: President, Abbott Morriss; vice-presidents, F. O. Smith and D. P. Paul; secretary-treasurer, C. L. Young.

Most of the cars in the city of Norfolk are used for pleasure only and are laid up in Winter. There are two reasons for this: the roads around Norfolk are very bad, and public and private garages are thin, frame buildings, affording no protection against freezing. There are two public garages, Harmon's and the Rambler, both with good repair shops; in addition there is one shop undertaking repairs only. There appears to be a splendid opportunity for a good brick garage here. Places of interest within twenty miles of Norfolk are numerous, especially along the shore. The country has no hills at all and only a few ten-foot rises.

Practically all kinds of automobiles are used in Norfolk, the most prominent makes being White, Rambler, Ford, Mitchell, Franklin, Peerless, and Oldsmobile.

Virginia Beach at some seasons of the year supplies an excellent course for ocean "breezing." But for racing the beach did not answer satisfactorily.

**G**REENSBORO, N. C., March 9.—Though automobile conditions are far from ideal in North Carolina, roads still being in a very elementary stage, Greensboro has about forty-five cars in regular use. The city does not yet possess an automobile club, though two garages and three agencies are maintained. The Greensboro Motor Car Company, with agency for the Ford line, possesses the best garage; the Caroline Motor Company, with agency for the Buick, has also a garage. Reo cars are handled by H. L. Hopkins.

Road conditions are bad in this neighborhood, the surface being formed of heavy clay. Steps, however, have been taken for the construction of a large amount of macadam road, 170 miles of improved highway having already been built and 40 more being under construction. Much of the road building in this section of the country is done with convict labor.

**W**INSTON-SALEM, N. C., March 10.—About eighty automobiles are owned in Winston-Salem. The formation of a club has been discussed on numerous occasions, but no definite move has been made up to the present. The majority of the roads in the county are of the clay variety, and consequently have little that is inviting to automobilists. Considerable activity, however, is being displayed in the construction of improved highways, the county having already done a large amount of work in this direction.

Maxwell, Cadillac and Buick are represented in the city, their respective agents being Winston Automobile Company, Forsyth Sporting Goods Company, and P. Somers. The two former maintain garages.

### INDIANAPOLIS NEARING THOUSAND MARK.

**I**NDIANAPOLIS, IND., March 9.—From a complete examination of the registrations filed with the Secretary of State, a local authority finds that there are about 800 automobiles in the city of Indianapolis. It is not reasonable to suppose, however, that all automobiles in Indianapolis are registered, due to the fact that the police have never made an effort to enforce this phase of the law.

The Premier, manufactured by the Premier Motor Manufacturing Co. of this city, stands at the head of local registrations. Other Indianapolis manufacturers show up well, and touring cars predominate, the majority of runabouts being used by physicians, salesmen and people in moderate circumstances. More than 25 per cent. of automobiles used in the city were manufactured in local plants.

The comparison made was taken from 5,000 automobile registrations, showing that about 16 per cent. of the automobiles in Indiana are owned in Indianapolis. City officials who have sought to enforce the city license ordinance have usually estimated that there were 1,200 automobiles in Indianapolis, or that about 25 per cent. in Indiana were owned in the city.

The number of automobiles in the city have more than doubled during the last three years. Until the close of the 1904 season there were barely 300 cars in the city, and they are now increasing from 150 to 200 a year. Indications are that at the close of the 1908 season there will be at least 1,000 automobiles in Indianapolis.

Automobiles having the greatest representation in the city are: Premier, 83; Cadillac, 61; Pope Waverly, 51; National, 51; Ford, 48; Olds, 40; Maxwell, 37; Autocar, 32; Marmon, 31; Rambler, 28.

Roads improvement has been marked in Indiana during the last two years, and the farmers particularly are now favorable to the betterment of the highways.

### PENNSYLVANIA AUTOISTS IN COUNTRY TOWNS.

**P**ITTSBURGH, March 8.—A careful investigation of automobile conditions in Pennsylvania shows that a majority of the 8,717 cars now in use in the State are owned by people living in the so-called country towns. It is in these towns that the automobile has come into general use for real service, while in the larger cities it is still largely a luxury and kept for show. There is not a good-sized town in the Keystone State which has not now from one to a half-dozen flourishing automobile agencies, and this year promises to be a much better season for these dealers than for the agencies in the big cities of Pittsburgh and Philadelphia. Second-hand machines are already in great demand, and the moderate priced 1908 cars are selling much better than one year ago.

Under the direction of Thomas I. Cochran, preparations are going ahead rapidly for the second annual automobile show of the Automobile Club of Pittsburg, to be held in Duquesne Garden in April. The Old King Cole Papier Mache Company has the contract for a large part of the decorations, which promise to be the finest ever seen in the Garden. Large eagles, speed wings, paneled ornaments, massive shields, and eagles will be seen on the marble pillars, and there will be ornamental balustration around the first floor.

### BAR HARBOR AGAIN AUTOMOBILELESS.

**B**AR HARBOR, ME., March 9.—By an overwhelming majority, Bar Harbor has voted to be an automobileless Eden during the coming season, as it has been during the past year. It is situated in the town of Eden, and at the annual meeting of the latter the vote stood 415 to 174 against permitting automobiles to run on what is known as Bay View drive, so that the atmosphere of Maine's chief summer resort will be free from the taint of half-baked gasoline and its roads unmarred by the track of pneumatics.

## SAVANNAH'S MEET WILL HAVE SPEED IN ABUNDANCE

SAVANNAH, GA., March 9.—Record speed is anticipated in the two-day races on the Savannah course, March 18 and 19. During a recent practice spin one of the entrants for the 360-mile contest traveled at the rate of 86 miles an hour for a distance of five miles on the flat, speedy course, and has made the inhabitants of the district certain that the Ormond record of 77 miles an hour will be beaten. Edgar Apperson, entrant of one of the first cars, gives it as his opinion that the course is the fastest in America.

Among those now practicing on the course are the drivers of the Isotta-Fraschini cars, five Appersons, and a six-cylinder Thomas Flyer. Everything is now ready for the race, and so much has interest increased that a number of additional entries to the seventeen already received are expected.

A race within a race that is attracting considerable attention is the \$1,000 challenge between the American roadster and the Apperson Jackrabbit. Both machines are reputed to be very fast, and are so evenly matched in power as to assure a very keenly disputed race. Either George Robertson or Herbert Lytle will be at the wheel of the Apperson. The American will be piloted by its designer, Fred I. Tone.

As a last step preparatory to the races the Savannah Automobile Club has become an incorporated body. Among the incorporators of the club are Mayor Tiedeman, Chairman of Council Richard J. Davant, who is chairman of the executive committee having the races next week in charge; President W. W. Williamson, of the Chamber of

Commerce; President Wright Hupnter, of the Board of Trade; Alderman Frank C. Battey, president of the club, and other well-known Savannahians. At the organization meeting of the club Mr. Battey was re-elected president and Arthur W. Solomon, secretary and treasurer.

### Pullman vs. Studebaker: Philadelphia to Savannah.

PHILADELPHIA, March 9.—Somewhere between this city and the Virginia-North Carolina line two local cars are floundering through the mud at a two-miles-an-hour clip in an endeavor to be the first to reach Savannah. The New Year's endurance run clean score Studebaker, whose owner has been carrying a big chip on his shoulder ever since that event, found an opponent almost at the last minute in the Pullman "Forty," after having made all preparations to start alone. The new conditions required some hustling, but after a slight squabble over the number of drivers to be carried and the fact that the Studebaker was a 30-horsepower touring car and the Pullman a 40-horsepower roadster, and a little delay in securing official observers, the two cars were sent away from the Hotel Walton at 8:30 A. M. Wednesday last. Heard from last Saturday, the Pullman was about 20 miles in the lead, between Fredericksburg and Richmond, the Studebaker having just arrived at the former place. It took 40 hours, six horses and two negro drivers to get the Pullman over the 50 miles between Centerville and Fredericksburg—about a mile per gallon of gasoline.

## A. L. A. M. MECHANICAL BRANCH ADOPTS STANDARDS

AFTER an interval of three months, during which a special committee had been experimenting and investigating, an unusually important meeting of the Mechanical Branch of the Association of Licensed Automobile Manufacturers was held Tuesday at the Transit Building, New York City, the results of which are given out in the following official report of the meeting:

The special committee appointed to work with the Test Committee toward the standardization of rod and yoke ends, made an elaborate report on what it considered the proper sizes for the standardization of these important parts of construction. Standards for 3-8, 5-16, 1-2 and 7-16 rods were adopted and will be known as the A. L. A. M. standard adjustable rod and yoke ends. With the adoption of this standard, the manufacturers of rods and yoke ends will carry in stock a full line of the standards adopted so that users of the sizes which have been adopted may be able to buy in the open market such sizes necessary. This is of particular benefit to the user as the parts will be interchangeable, and the rods of one car will do for another.

Another important standardization was that of levers. Various weights and sizes of levers have been used with a considerable expense to those automobile manufacturers who do not have drop forging plants. Owing to their inability to buy stock levers, they must necessarily buy the dies from which these forgings were made and with the changing of the type or weight of the lever, new dies, at an increased expense, are necessary. After careful consideration, the Branch adopted a uniform modified I beam lever, which the drop forge makers will carry in stock.

The committee appointed to report on the standardization of rims felt that the time was not ripe for a universal adoption of the standard rim, owing to the fact that it was impossible to tell whether the clincher or demountable rim would be in vogue. The use of spare wheels instead of demountable rims was given consideration and the Rim Committee empowered to make a further investigation on this matter.

At the afternoon session, Dr. Charles Edward Lucke, of Columbia University, who has been making some very exhaustive tests with alcohol as a fuel for internal combustion engines, delivered an address to the Branch. Dr. Lucke's remarks were principally in making comparisons in the tests he had made with the use of alcohol or gas engines for locomotion as compared to those for stationary

use. He pointed out clearly to the Branch that with certain types of engines he could start with alcohol as easily as gasoline, by the use of a spray carburetor with the ordinary needle valve. He said that he did not feel that the time was opportune for a universal adoption of alcohol for practical use, especially in automobile engines, owing to the absolute necessity for a minute adjustment of carburetor and ignition which could not be had in automobiles, owing to the inexperience of many drivers and owners.

E. R. Hewitt, who has been experimenting with alcohol for commercial purposes, gave some interesting data on the results of his work. Mr. Hewitt adapted an engine to the use of alcohol for a five-ton truck. On gasoline with a full load 4 1-2 miles on a gallon of gasoline could be had. On using the motor without readjustment, only over two miles per gallon of alcohol could be gotten, but on raising the compression from 75 to 120 pounds, he was able to get over five miles to the gallon of alcohol. He pointed out that it was necessary in this case to place the carburetor as near the engine as possible in order that the mixture would be sent into the cylinder not less than 72 degrees. In cold weather he was able to overcome the loss in the vaporization by surrounding the in-take pipes with the water jackets which kept an even temperature for the vapor until discharged into the cylinder. It was the consensus of opinion that for commercial work alcohol, in the near future, would be the most economical fuel to be used. An interesting lecture on the use of pyrometers for indicating and recording the heat temperature in treating steel, was delivered by W. H. Bristol and Charles Engelhard.

The session closed with the annual election of officers. This resulted in a unanimous re-election of the present incumbents, which were: A. L. Riker, Locomobile Company, chairman; Coker F. Clarkson, secretary; Henry Souther, metallurgist with H. E. Coffin, Thomas Detroit Company, chairman of the test committee. Those present were:

John A. Baumgardner, Autocar; A. N. Manross, Corbin; H. P. Maxim, Electric Vehicle; J. H. Becker, Elmore; John Wilkinson, Franklin; Charles Lohr, Haynes; E. R. Hewitt, Hewitt; H. G. Farr, Knox; E. F. Russell, Locomobile; Charles R. Greuter; V. N. Gunderson, Northern; Geo. B. Dunham, Olds; Allen Loomis, Packard; L. H. Kittredge, Peerless; David Ferguson; Robt. Jardine, Royal; Alden Sampson, 2d, Sampson; E. T. Birdsall, Selden; Henry Hess, Stearns; John G. Utz, F. P. Nehrbas, Thomas; F. D. Howe, Waltham; C. D. Smith, Winton; Henry Souther, metallurgist; A. L. Riker, chairman; Coker F. Clarkson, secretary.



Captain Hans Hansen, ex-De Dion Pilot, Meets Roberts and the Thomas Car on Which He Will Continue to Paris.

**AMERICAN INCREASES LEAD IN PARIS RUN.**

Rapid progress has been made through Nebraska and Wyoming by the American contestant in the New York-Paris run, the Thomas at the end of the twenty-seventh day being more than 300 miles ahead of its nearest competitor. Montague Roberts made a fast sprint of 105 miles into Cheyenne, there turned the car over to E. Linn Mathewson, and returned east to fulfill his racing engagements. It is now certain that the leaders will push ahead under their own power to San Francisco, instead of being shipped from Ogden to Seattle, as originally announced. Captain Hansen, who started as pilot of the De Dion, and was unable to work in harmony with Saint-Chaffray, has joined the Thomas car and will continue with it to Paris.

The French De Dion has had a vein of ill-luck since its Norwegian pilot threw up the command. After five days lost at Cedar Rapids making repairs, the car set out only to break down again at Omaha, where it will be held at least three days more. The driving shaft was broken in the run through Iowa; repairs made in local shops proved unsatisfactory, and it will be necessary now to wait for spare parts shipped from France and already received in New York.

The Italian Zusta, after repairs in the Union Pacific shops at Omaha, Neb., is pushing ahead rapidly, has now left the De Dion 360 miles behind, and with promise of better roads ahead may diminish the distance separating it from the American car.

Changes have taken place in the composition of the Protos crew, Engineers Hans Knappe and Ernest Maass having abandoned and returned to Europe, after a disagreement with Lieutenant Koeppen. The two army officers put forth as their grievance that Lieut. Koeppen, a passenger and newspaper correspondent unacquainted with automobiles has been receiving all the glory and monopolizing all attention.

Charles Godard, who has been awarded the title of "Baron" since going west, is playing a trailing game, being now about one thousand miles behind the leader. He has met with frequent mishaps, complains of excessive charges, the bad roads, and has asked and been refused permission to ship his Motobloc on the railroad. Mileage for the last seven days is as follows:

Car.	Country.	day. 22d	day. 23d	day. 24th	day. 25th	day. 26th	day. 27th	day. 28th
Thomas (America)	.....	1,536	1,627	1,767	1,908	2,052	2,109	2,206
Zust (Italy)	.....	1,458	1,467	1,488	1,536	1,536	1,690	1,878
De Dion (France)	.....	1,262	1,262	1,262	1,262	1,313	1,331	1,331
Protos (Germany)	.....	1,043	1,043	1,043	1,078	1,118	1,181	1,262
Motobloc (France)	.....	1,043	1,043	1,043	1,093	1,101	1,101	1,101

**BLAZING THE WAY FOR THE ZUST CAR.**

By JOHN W. BREYFOGLE.

"Everybody out, please. Now, gentlemen."  
 "Ze oil? Oui." Purr-r-r, bang. "C'est très mauvais."  
 "This the German car?"  
 "Naw. Can't you see it's built in R——."  
 "What you mean by Gearless?"  
 "Go to"—wrrir-r-r, bang, bang, pop, s-s-s.

Silence for a moment, then from aloft, a fierce-eyed figure in Turkish veil and nightgown roared, "Get out." More silence, then an awed whisper:

"That's Hansen; he's the fellow that went to the North Pole."  
 "'Taint Hansen; he's with the Ger——" Bang, bang, bang.

"What time you lave?" "How much horse,—frict—drive,—how," pop, spt, whirr, r-r-r bang. Then somebody thought of the hose and we had peace.

They did not exactly leave the dinner table of the Geneva Club. They faded away, each with the be-back-in-a-minute air, but straight to the garage they went and tuned, tuned, tuned; each with one ear on the other fellow's motor and smiling like a dozen women after the same hat.

Something was going to be doing on the morrow. "Let us continue together," said Saint-Chaffray. "Let us follow the beautiful pilot car; we shall enter Rochester together like brothers; the flags shall entwine, it shall be a glorious." "Sure," said Ruland, as Sirtori grinned. Roberts merely tuned. It was nearing Buffalo and entwining was bad business.



Gearless Pilot Car Which Broke the Way for the Zusta.



When we hauled up at the roadside to await Züst, no one knew it for the beginning of a long winter trip. Like the Great Harry she came—the Züst—high of poop and low of stem, thundering broadsides across the snow waves, and the Gearless dived for its place and the trip was on. Soon we made up the two miles the tardy one had lagged behind and caught the leaders only to see the Thomas disappear in the distance, while De Dion blocked the road in a drift. Then came the grinding of a chain guard in a sprocket, a broken radius rod, and the "Great Harry" limped into Rochester to the home of its pilot for repairs.

#### Midnight Adieux, then a Plunge into Snow.

It was the following midnight as Züst said her goodbye to the crowd of Italians who had hung for days around the Four Corners and Powers Hotel, and started over the crackling snow in the pilot car's wake. It was cold. At least we thought it was cold then. We were to acquire knowledge later. Following the frozen Genesee on through Scottsville and LeRoy, the old, old way, but oh! so different in the frosty moonlight, we arrived at Batavia and found—nothing. The Buffalo pilot car was not. Doubtless they were waiting at the city line with the city keys and glad hand, but at that point there was naught but an Owl car, and the attendants of the garage whom we aroused merely replied to our queries about Thomas and De Dion with the one word, "went." So we went likewise, and at once, to discover at Silver Creek that there was much pother in the Sleeping City, hasty repairs, curses and mighty preparations for pursuit. Finding ourselves in the lead, we cut the pace to decercy, with visions of Ashtabula as the night's stop. But Ashtabula turned Ripley and more radius rod repairs when, after another all-night job, we again took the road. De Dion and Thomas were seventy miles ahead, and crippled Züst lost steadily to Cleveland, one hundred and twenty-seven miles behind.

To Cleveland the way had been normal and lacking in any special characteristic, but beyond in the storm lay a land of romance. At midnight when the long dark rows of houses seemed a continuous prison wall, when the snow drifted over the deserted streets, covering the car tracks like a ragged garment, when the lights burned dimly like tapers upon ancient graves, when no living thing stirs, when the snow mounds seem to cover the debris of a long ruined city and all is deserted and cold—in such a night to start for nowhere is dismal. Once the lights of Rockey River were behind, there were no others, nor was there a road. Mile after mile the cars ploughed a trackless, rolling plain, undistinguishable from the fields which skirted it. Houses fell to ruins. Twice only we paused, once as the pilot car fell into an unseen hole beneath the snow, and once again to tighten a clutch, upon which we worked by dim lamp-light like ghouls, while the snow muffled all sound; then on again.

Noon brought Toledo and breakfast, and a counsel, as we took stock of our forces; things were beginning to be a bit lazy by now. Ruland had had no sleep, save in the car, since Rochester; Wilcox was down with the grippe and the rest of us wobbled a trifle in our walk, but Thomas and De Dion were still ahead, so we decided to continue.

Before, the snow had merely been a discomfort, but now it began to be a hindrance, and the further we went the more hindrance it became. Thirty miles out, at Wauseon, after six hard hours, the good innkeeper brought forth hot coffee and hot "dogs," and a storekeeper opened his store, and such a buying—overcoats, shirts, gloves, boots and socks.

It was some four hours later that we encountered that strange hill in the road. It began just under the radiator and went up and up, but the most peculiar part of it seemed to be that we could not catch it. How far we chased it no one can tell, but finally we got our front wheels on it. Just then the lights went out. When they came on again, the writer was draped over the back of a seat and Shannon was at the wheel. I know perfectly well what brought me to—it was the absence of Züst's strange popping exhaust, and upon looking back all was darkness. Five miles behind; when we got there the matter stood explained.

Sirtori had met that strange hill, too, and Züst was in as nasty a snow ditch as was ever seen, and careened until her gasoline would not flow to the carbureter. For two immortal hours the Gearless tugged at that seventy-five hundred pounds of ditched dead weight and inch by inch drew it into the road; then, without stopping for breath, we tumbled in and arrived in due time at Bryan. That was a fine town, that Bryan, and it sported two hotels, but one was too fatigued to furnish breakfast and no one could find the other, so we untangled the local whiskers from out our machinery and moved on.

#### Strenuous Driving Brings Its Reward.

Night, our third of continuous driving, overtook up in the wilds. We were in Indiana, and knew it, too, by now. It was here that Ruland produced those famous frozen eggs, which we thawed out and ate in great gulps. We had now, at 8:00 P. M., been driving sixty hours continuously, save the two hours Sirtori and the writer napped it at Cleveland, but sleep was far from us, for we were nearing Kendallville and there were Thomas and De Dion. Averaging three miles per hour, we continued, ramming snowdrifts and digging ourselves out. At midnight we met our worst drift and here things became serious, for after being in it for two hours, we began to have trouble keeping each other awake; then, too, the drift made faster than we could dig it away. Finally we ahead grew desperate, and jumped and plunged with the Gearless until the drift opened and we passed on our way, arriving and basking in Saint-Chaffray's smile at 3 A. M., after sixty-seven hours on the road, and after reducing the one hundred and twenty-seven miles to a bare eleven; for the Thomas, at our approach, had left in the night and moved to a little town ahead. The remainder of the trip was uneventful, snows were deeper, going was harder, but we slept and ate, joined mostly with De Dion and content to travel with our friends. Züst lost a full day at Kendallville, due to no other cause than that at New York in the custom house, the car stood with full radiator and, in spite of repeated protests, none were allowed to touch it. The result was a frozen radiator, which split across the top.

Without sleep, without food, fierce looking, wild-eyed men. Ahead a long red demon and behind the "Great Harry," filled with untamed Cossacks, and barking defiance across the land. And these men and this great ship on wheels, this seventy-five hundred pounds of car, clothing, rifles, provisions, parts and even tallow candles, twenty pounds of them, are to cross the world and tackle the Polar. Oh! the wonder of it, the wonder of it.

#### FOREIGN TOURING LITERATURE BY MAJA CO.

Foreign touring becoming more and more popular among automobilists, the American branch of the Maja Company, Limited, has added a publication department to its touring bureau, and will shortly publish a very complete "Guide Book to European Touring," by E. B. Gallaher. The work outlines a large number of touring routes throughout Europe, in conjunction with a series of modern maps, gives a full list of agencies, garages, hotels, official stopping places, information regarding shipment of cars, custom details, police regulations, and local and governmental laws throughout Europe. Reproductions of the forms which must be filled out for all licenses and other applications are included.

#### PARIS POLICE WAITING FOR FRENCH DRIVER.

PARIS, March 2.—Interest in the New York-Paris "race" in the French capital is confined almost entirely to the columns of the *Matin*. All other journals, technical and otherwise, criticise and ridicule the event. Several papers state with sarcasm that Godard's reason for remaining in the rear is that he has been condemned since his departure to eight months' imprisonment and the repayment of 5,000 francs obtained under false pretenses during the Pekin-Paris run.

## BUFFALO'S SHOW VERY ATTRACTIVE AND SUCCESSFUL

**B**UFFALO, March 9.—Broader in scope, better in exhibits, and more beautiful from the artistic viewpoint, the sixth annual automobile exhibition of the Automobile Club of Buffalo and the Automobile Trade Association opened in Convention Hall to-night under most auspicious circumstances. If the tremendous crowd which attended to-night is to be accepted as a criterion of the week, the automobile show of 1908 will go down in history as a success from the commercial, financial and social viewpoint. President Frank B. Hower of the Automobile Club, President John A. Cramer of the Automobile Trade Association, and Secretary D. H. Lewis of both organizations, were unanimous in their expressions of satisfaction over the arrangements and the prospects for the show during the balance of the week. Previous automobile shows held in Convention Hall have opened in the morning of the first day of the exhibition, but owing to the inability of the management to obtain possession of the auditorium until Sunday afternoon, it was impossible to finish the decorative work before this afternoon.

In brilliancy and artistic effect, the decorations surpass any previous exhibition ever attempted locally. The designer was Albert Hutter, and he reached the acme of decorative perfection. The decorations are simply magnificent, and the crowds, upon entering the hall, expressed admiration audibly. Band concerts will be held every afternoon and evening by the 65th Regiment Band.

Automobiles of every make and description are on exhibition. Trim roadsters, big touring cars, neat runabouts, stately landaulets and limousines and commercial wagons and trucks are shown. One of the first exhibits that greet the eyes of the admiring throngs is that of the George N. Pierce Company, which faces the main entrance. The Great Arrow is to be seen here, fresh from the factory and complete. There are big sixes and little sixes, Great Arrow 60-horsepower and Great Arrow 40-horsepower, and others.

Close by is the E. R. Thomas exhibit, continuously surrounded by an admiring crowd. Cars ranging from the little 16-20-horsepower town-car to the big six-cylinder flyer, which is the largest and most powerful automobile made in America, are displayed. The Thomas Company has nine different styles of cars on four styles of chassis. There are three Thomas Detroit cars at the show.

Three finished vehicles and a chassis composed the exhibit of the Babcock Electric Carriage Company. The concern also manufactures three other styles of vehicle. The chassis shown is the same as that on which the victoria and the coupe bodies are placed.

Diamond tires are exhibited by the Diamond Rubber Company. There are thirty-five exhibitors at the show.

### Boulevard Day to Be a Notable Local Event.

Thursday will be Boulevard day, when the admission price will be one dollar, and all receipts turned into a fund for the Niagara Falls boulevard. All the automobile manufacturers and agencies are booming Boulevard day, as everybody owning an automobile wants to see the much needed Niagara Falls boulevard completed.

The New York State Automobile Association will meet at the Automobile Club rooms on Thursday, and, after a dinner at the Buffalo Club, the directors will attend the automobile show and will thus contribute to the boulevard fund.

The list of exhibitors includes the following:

Maxwell-Briscoe Buffalo Co., Co-operative Auto Co., E. R. Thomas Motor Co., Poppenberg Auto. Co., Lewis & Linn, Brunn Carriage Mfg. Co., J. A. Cramer, Babcock Electric Carriage Co., Geo. N. Pierce Co., Imperial Motor Co., Buffalo Automobile Exch., Centaur Motor Co., E. E. Denniston, United Spring Co., American Leatherette Co., Jaynes Auto. Supply Co., Empire State Tire Co., Chief Mfg. Co., Meyer Carriage Co., Jas. G. Barclay, Iroquois Rubber Co., Walter Hayes, John W. Frey, Buffalo Motor Car Co., D. H. Lewis, Knoll & Turgeon, Neal, Clark & Neal Co., C. E. Miller, W. F. Kendt, Harry Brainard, Harris E. Newton, Louis Engel, Jr., Model Auto. Co., W. F. Polson, International Acheson Graphite Co.

## 'FRISCO'S SHOW NOTABLY CONDUCTED BY WOMAN'S CLUB

**S**AN FRANCISCO, March 4.—On the morning of March 2, San Francisco witnessed its first decorated automobile parade. It was the occasion of the opening of the second automobile show, to be held in this city, which is under the auspices of the California Woman's Automobile Club. Shortly before 9 o'clock, one of the heaviest showers of the rainy season fell, and much trepidation was felt for the success of the opening event, but about 10 o'clock the clouds broke away and the sunshine smiled on the assembling cars.

It was a few minutes after eleven, however, when the marshal, Mrs. L. E. Morrill, in her beautifully decorated Franklin touring car, led the long line from the rendezvous at the head of Van Ness avenue. Preceding the car of the marshal were two large Thomas cars, filled with members of Bennett's band. Following the Franklin came the artistically decorated Maxwell runabout of the president of the California Woman's Automobile Club. The car was a mass of big yellow chrysanthemums and blue cornflowers, these being the colors of the organization. With Mrs. Frederick J. Linz, the president, was Mrs. Abbie Krebs, the vice-president. Mrs. Robert Christy, secretary of the club, followed next in a beautifully decorated Elmore touring car. Mrs. Christy was accompanied by a party of friends, composed mainly of members of the club. A big Thomas flyer was seen in the line of march, heavily draped in "Old Glory,"

which sent a thrill of patriotism through the hearts of the spectators as it proudly swept up the street. Another car which brought a cheer from the crowds on the sidewalk was a Maxwell touring car, so decorated as to represent a man-of-war, at the wheel of which sat a sailor, and in the tonneau Goddess of Liberty rode. This was awarded the second prize, as being the most novel and cleverly carried out design.

The winner of the first prize, Mrs. J. M. Etienne's White steamer, was completely covered in pink and white carnations, and gold butterflies and fleur-des-lis were sprinkled over the canopy of color, and a huge gilt sphere hung in the center. Mrs. Etienne had as her guests a party of women friends, all of whom were gowned in pink and white. This clever motorist drove her car and excited many admiring remarks. At the Coliseum, the judges awarded the prizes: the first, \$75, to Mrs. J. M. Etienne, and the second prize, \$25, to the Maxwell "man-of-war."

In the evening at 8 o'clock the doors of the Coliseum were thrown open to receive those who had been in the evening parade, which was even larger than the morning, and to the hundreds who had come out on the cars to witness the event. Mrs. Fred J. Linz introduced W. Parker Lyons, mayor of Fresno, who formally opened the exhibition, and after a few words of congratulation to the members of the California Woman's Automobile Club, introduced the speaker

of the evening, Wu Ting Fang, Chinese Ambassador to the United States, who was en route to Washington. His Excellency was very happy in his remarks, stating that he was glad the fair sex had achieved what the men in the trade had failed to do, and showed great interest in the exhibits.

#### Results of the Hill-climbing.

Tuesday afternoon was devoted to the first of the hill-climbs, the course lying from the front of the Coliseum to the summit of Buena Vista Heights, which is one of the finest courses for such an event for some miles around, having a number of quite perceptible grades and sharp turns, on a gradual rise.

The first event, for runabouts, was won by a Maxwell driven by Clarence King, a mile and one-eighth, in 2:55.

Second event, for runabouts, value \$1,500 and under—Won by Tourist, driven by Edgar Mason, time, 2:09; second, Auburn, 2:29 4-5, driven by Frank Bryant.

Third event—free-for-all roadsters and runabouts—Won by Stearns, driven by D. A. Bonney, in 1:42; second, Winton, 2:20 2-5, driven by H. L. Owsney.

Tuesday night was under the patronage of the Automobile Club of California, and a large sprinkling of the smart set were in attendance at the show. Mrs. Fred J. Linz presented the winners of the afternoon events with handsome silver and copper cups, appropriately engraved.

The hill-climb for touring cars which was to have taken place on Wednesday had to be postponed on account of the wet weather, and will take place next Saturday.

#### White Wins in Three Touring Class Events.

SAN FRANCISCO, March 7.—In the hill-climbing contest postponed from last Wednesday owing to rain, a White steamer model L won in the \$2,500 class; a White model K captured first place in the \$3,500 class, and the same car made fastest time in the free-for-all race.

#### NEWARK'S SUCCESSFUL SHOW WILL REPEAT.

NEWARK, N. J., March 10.—So great was the success of the recent automobile show in Electric Park that it has already been decided to hold a second exhibition in the early months of 1909. W. H. Ellis, secretary of the New Jersey Automobile Trade Association, has applied to the Essex Troop for the use of its new armory, under construction on Roseville avenue. In both size and location, the Essex Troop Armory is superior to Electric Park auditorium, being near the Orange street car line, only a few blocks from the Warren street line and adjacent to the station of the Lackawanna Railroad.

The auditors' accounts show that the profits on the recent show will allow a rebate of nearly 10 per cent. on exhibition rental to all exhibitors. The members of the New Jersey Automobile Trade Association, who cooperate with the New Jersey Automobile and Motor Club in the holding of the show, will receive a larger return. There is a desire on the part of the officials of the automobile club to use the money for the purpose of erecting road and danger signs where the Department of Motor Vehicle Registration and Regulation has neglected to do so.

Prominent among the removals in "automobile row" next month will be the change of J. W. Mason to Halsey street, near Marshall street. The F. L. Boland Company will occupy a new one-story building at Halsey street and Branford place about May 1. With its removal, the company will change its name, F. E. Boland having withdrawn his interest in the concern. The Linkroum Automobile Company, agents in Northern New Jersey for the Lozier car, will remove from Bank street to Halsey street.

#### HARRISBURG ENTHUSIASTIC FOR SHOW.

HARRISBURG, PA., March 10.—Providing a suitable building can be obtained, an automobile show will be held here next April, under the auspices of the Motor Club of Harrisburg. Members of the club are strongly in favor of the exhibition, and, if suitable accommodations can be secured, it will certainly be held. The club has recently appointed the various working committees for the ensuing year.

#### PERFECT SCORERS IN MID-PACIFIC CONTEST.

HONOLULU, T. H., Feb. 24.—Nine American automobiles lined up in the second annual competition of the Automobile Club of Hawaii for the Von Hamm-Young Company challenge cup. E. L. King's White steamer, Frank Dillon's Buick, Sidney Jordan's Maxwell, E. Quinn's Buick, and J. Lewis' Franklin were the five to finish the round-the-island run with perfect scores.

#### TOLEDO OPTIMISTICALLY PREPARES FOR SHOW.

TOLEDO, O., March 9.—Toledo's second annual automobile show will probably be held some time during the latter part of March, very likely in the Coliseum. The show last year was the biggest advertising stunt the local dealers ever participated in, and almost every exhibitor was well repaid for the time and money expended. This year the entire north-western part of Ohio is to be covered with advertising matter, special rates are to be secured on the electric lines and on the steam roads if possible, and the Chamber of Commerce is figuring on joining and making the affair a general boost for the city as well.

Local automobile agents are expecting the best season they have yet had, despite the financial trouble of a short time ago. Prospective purchasers are plenty, and selling agents are now coming forward with advice to prospective purchasers to place orders early, as there is almost sure to be a shortage of cars before the season is ended. This shortage, they say, is due directly to the financial flurry, which caused many manufacturers to curb their operations.

Toledo is in the best possible condition to look after the automobile needs of this section of Ohio. A number of new garages have been equipped since last year, some new agencies have been established, and the stock of cars on exhibition at present is larger than ever before.

#### A CANADIAN TOWN'S ANSWER TO PROGRESS.

MONTREAL, March 7.—Charlottetown, P. E. I., is the name of the town which must be given the award for excelling in grandmotherly care for the automobile. Recently the Board of Trade of the township passed a resolution calling upon the government to cause all automobiles to be kept at home Sundays, Tuesdays and Fridays. Other regulations fenced in the automobile in such a stringent manner that there was no possibility of it ever overworking itself. A delegation from the Presbyterian church submitted complaints of their congregation that automobiles deterred many people from going to church.

#### ARRANGEMENTS COMPLETE FOR HOOSIER SHOW.

INDIANAPOLIS, IND., March 10.—All arrangements have been completed for the second annual automobile show, which will be held here March 23-28.

There are now thirty entries in the hill-climbing contest, and almost as many for the obstacle race. Permission has been granted to hold the latter on the North Capitol Avenue boulevard. It has been decided not to hold a formal banquet, but to substitute a smoker and lunch.

**NEW THINGS UNCOVERED AT BOSTON SHOW.**

*(Continued from page 346.)*

the car was driven at a speed of 25 miles an hour over this combination of tire-destroyers without any damage resulting. The car was subsequently driven over the nail-studded boards at the slowest possible speed, but the result was equally favorable. The usual type of inner tube is employed in the Zeglen tire, and it does not differ from others in appearance.

**Suthergreen Tireholder.**—One of the novelties that has to do with the manner of carrying spares, rather than with the tires as such, is the Suthergreen swinging tireholder, made by F. S. Suthergreen, Manchester, Mass. Obstructing the driver's seat with the spare tire has long been one of the objectionable features of the usual method of carrying this indispensable replacement on the car, making it necessary to enter the car from the off side. This new tire holder swings out of the way in exactly the same manner as side entrance, and in addition to facilitating entrance to the driver's seat, it also makes that side of the car readily accessible for cleaning and oiling. The holder is not only made to swing out of the way, but by the removal of a single screw and pin, the holder and its tires may be lifted off completely.

**Sterling Spark Plug.**—Though its name is similar, the Sterling spark plug for heavy duty, shown for the first time, is not another product of the firm in question, but is made by the Windsor Manufacturing Company, Worcester, Mass. Its chief feature is the employment of a vibrating electrode, which makes it impossible for oil or soot to collect on it, as the motion of the car and the motor cause it to vibrate rapidly. Its design is such that the readjustment of the sparking points is never necessary, as the distance between the surfaces remains unchanged, even though considerable of one of the electrodes happens to burn away. A special core of porcelain reduces the danger of cracking to a minimum.

**"Oilzum" and "Cleanzum."**—White & Bagley, Worcester, Mass., makers of the euphoniously christened "Oilzum" gas-engine oil, provided a novel treat in the shape of a huge glass-spoked wheel, the spokes being filled with translucent and transparent samples of lubricating oils, which showed to good effect, owing to the illumination placed behind them. Lubricating oils do not lend themselves readily to display purposes, on which account this novel and ingenious method of calling attention to them provoked more than the usual amount of interest. The same firm also showed the cleaning compound, which they have christened "Cleanzum," in an attractive manner.

**"Boston" Acetylene Gas Tanks.**—These tanks are newcomers, though they are the production of men of long experience in the business, George S. Atwater, who has been making bicycle and auto lamps and generators for a decade past, being the manager of the company, which is known as the Boston Autolight Company, with headquarters at 751 Boylston street. The tanks measure 6 by 24 inches, and are highly finished in copper or nickel, with bands to correspond. Their capacity is 60 cubic feet of gas, and they list at \$35, the price of recharging being \$2.

**Anderson Glass Spark Plug.**—An ignition novelty that is otherwise well known but which made its first appearance at a show in Boston this week, is the Anderson glass spark plug, or, as the makers call it, a "window" to the engine. It consists of glass pyro-electric welded directly to steel, and when in place in the cylinder the character of the spark may be noted by merely looking down on the top of the plug. It is made in a number of sizes and special styles in both metric and iron pipe threads. These plugs are made by the Anderson Spark Plug Company, Washington, D. C.

**"Valgrinok."**—An entirely newcomer is the National Valgrinok Company, 116 Bedford street, Boston, Mass., a firm that is placing on the market a special abrasive compound



This Big New England Factory Was Well Represented.



A Representative Trio that Was Capably Staged.



The Packard and Cadillac Showed Complete Lines.

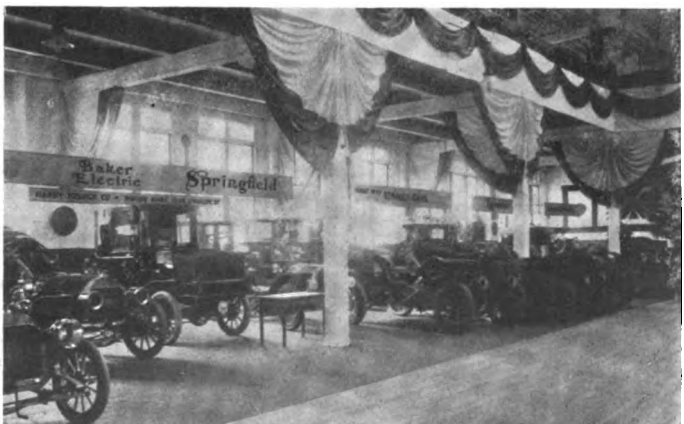

Atlas, Baker Electric, Springfields—Renaults, Next Stand.





Truffault-Hartford Showed an Imposing List of Users.

under the title of "Valgrinok." It is ready mixed, in the shape of a paste, and three grades, coarse, medium and fine, and is packed in a box. It is guaranteed not to dry up or shrink, and is designed to be applied with gasoline, oil or kerosene.

**Kenney's Non-carbon Oil and Olivine Compound.**—These new articles are made by the F. Kenney Manufacturing Company, 360-368 Dorchester avenue, Boston, and were shown at the stand of the Gordon Automobile Supply Company. Harry Eisner, who is manager of the Gordon Company, has control of the marketing of these lines, which includes, in addition to those mentioned above, Kenney's non-fluid grease, liquid metal polish, and a new hand soap. The Olivine is a non-alkaline compound for washing automobiles.

**Atlantic Brand of Oils and Greases.**—One of the new entrants into the field of automobile lubricants is the Atlantic brand of oils and greases, which are made by the Atlantic Refining Company, Cleveland, O., who are showing in the New England territory for the first time. They make a number of different grades for the various special uses about an automobile.

**Smith "One-lock" Adjustable Reamers.**—Smith "one-lock" adjustable reamers, the blades of which are ground with a radial clearance from the cutting edges. These reamers are made from 3-4 inch to 6 3-4 inches in diameter, and are supplied with either carbon or high steel blades.

**Ball-bearing Tire.**—Another novelty in this field is the Ball-bearing tire, made by the Ball-bearing Tire Company, 159 Avon street, Providence, R. I. As will be apparent from the accompanying longitudinal and cross sectional views shown

herewith, the construction of this tire is, in some respects, along the same lines as the familiar standard types. The shoe is composed of various layers of rubber and fabric vulcanized together, and an inner tube is employed. But between this inner tube and the shoe are placed two continuous strips of sectional molded rubber with a series of circular openings, as shown by the longitudinal view. These holes are filled with permanently inflated rubber balls, similar in construction to the inner tube, and from which the tire takes its name. As these balls and their holder are placed between the shoe and the inner tube, anything penetrating the former must pass through them before reaching it, thus making the tire practically puncture proof. A nail or other sharp object going through the shoe of the tire could not deflate more than one of the balls, and the loss of resiliency

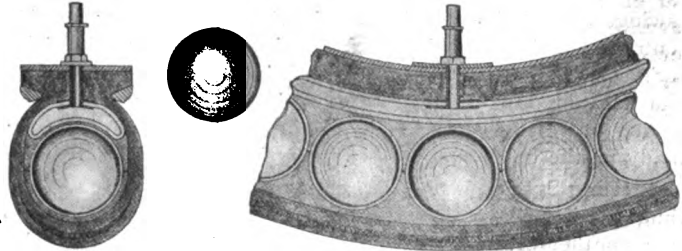

Sectional Views Showing New Ball Bearing Tire.

caused by this would be so small as to be unnoticeable. In fact, several of the balls at different parts of the tire could be punctured before the effect would be noticed, and a little extra air pressure on the inner tube proper would compensate for this, until the balls could be removed and repaired, an operation practically similar in every respect to taking out a tube for the same purpose.

**Standard Speedometer.**—Among the 1908 newcomers is a speedometer, known as the "Standard," which is being manufactured and marketed by the Parker Manufacturing Company, Boston, a firm that has made a specialty of high-class instruments for many years past. As will be apparent from the accompanying illustration, the mechanism of the new speed recorder is of the centrifugal type, but is extremely simple and compact, having but a minimum number of parts. It is operated by a train of gearing direct from the governor weights to the indicating hand, without the intervention of cams or levers, which are lacking in its construction. The governor weights are attached to two pivoted gears which revolve together with the main spindle and mesh with a circular rack which is moved lengthwise on a central spindle. This comprises the entire revolving mechanism, and is mounted on a hardened ball bearing. The remainder of the mechanism is stationary, with the gear always in mesh with the revolving circular rack, but is not subjected to any spring pressure. The gears are very accurately made of hardened steel and mesh with bronze, which insures long life. The pointer itself is attached to the upper end of a spindle with a very long bearing, and is operated by the upper train of stationary gears. This construction gives a speedometer of the centrifugal type, with a uniformly spaced dial, without the necessity of employing cams and levers to bring about this result. In other words, the governor weights

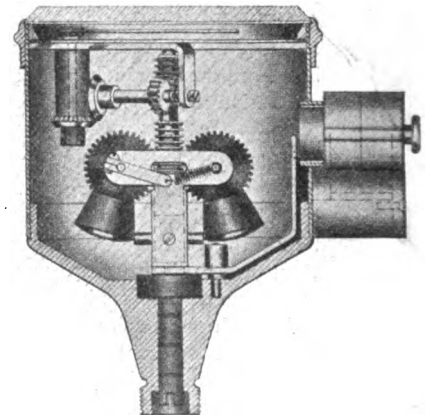

Inside View Standard Speedometer.

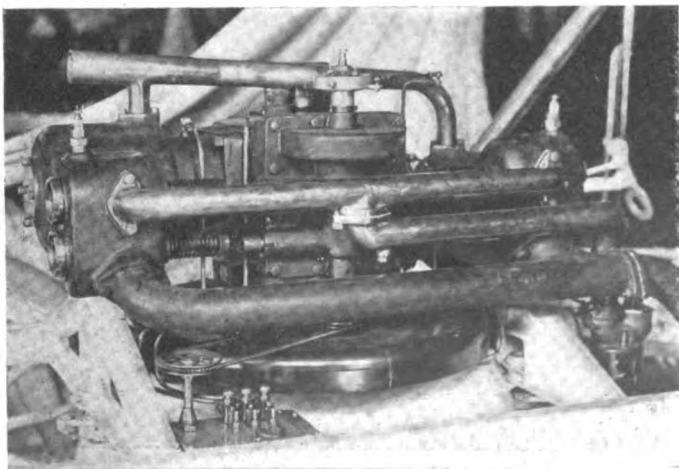

New Blomstrom Motor with Crankshaft Arranged Vertically.



In the East Gallery of the Main Exhibition Hall Many Houses Well Known in the Trade Made Effective Displays.

move exactly in proportion to the movement of the hand at all speeds. The only springs are those employed on each side of the governor, one of which shows in the illustration. The governor weights are designed to exactly counteract each other, so that vibration has been reduced to a minimum. Another feature of the Standard is that both the speed recording part of the instrument and the odometer operate whether the car is running forward or backward, the latter adding to the mileage just as if going forward. The calibrating of the dials is done with the aid of a special calibrating machine, the process of adjustment being so simple as to practically eliminate any possibility of error. The Standard is made in a number of types, ranging from zero to 40 miles, zero to 60 miles, and zero to 80 miles an hour, including a model with a maximum speed hand.

**Accessories of Various Kinds.**—In the field of windshields, the Nonpariel Brass Company, Providence, R. I., are newcomers, who show a line of brass and mahogany framed windshields of attractive design and finish, as well as ingenious types of tireholders, robe racks and other brass specialties.

A novelty that attracted no end of attention from the nature of its radical departure from previous standards in this field is the Half-Nelson emergency tire, shown by the Wood Carving Machine Company, Minneapolis, Minn. It is designed to stow away readily in the tool box and yet be ready at any time for an emergency blow-out or puncture placing one of the pneumatics out of commission, and con-

sists of a number of sections of what is practically a solid rubber tire of the same size as the pneumatic it replaces. These sections are put on the rim one after the other and hooked together, the whole being tightened up by a turnbuckle arrangement.

The Draper Auto Robe Company, Canton, Mass., shows a complete assortment of all kinds of robes specially designed for automobile use, including a wide range of patterns in attractive styles.

Shove & Gage Company, Inc., Providence, R. I., is on the market with a new brand of polishes, namely, the U-Auto polish and the Shine Bright. An effective display of the same is made in the accessories department.

**Two New Motors.**—There has seldom, if ever, been a Boston show that did not bring to light one or more radically different novelties in the shape of motor design, and the appearance of the Blomstrom motor, shown in the cut on the opposite page, is sufficient evidence that the present function has maintained traditions. This motor is of the two-cylinder horizontal opposed, four-cycle type, but instead of being placed either transversely or longitudinally under the body, it is arranged lengthwise under the bonnet with its crankshaft vertical, in which respect it differs entirely from any arrangement of the power-plant of an automobile ever attempted. Upon a little consideration, it will be seen that this placing holds numerous advantages, particularly where the flywheel is utilized as one of the members of a friction transmission, as is the case here. As will be evident from the



How the Main Floor and West Gallery Looked to the Observer from the Southeast Corner of the Main Building.

photo, this placing not only permits of a long stroke motor of this type being employed under the bonnet, but renders every one of the small parts particularly accessible, the timer, force-feed oiler and carbureter all being in plain view and easy reach. In addition to its other advantages, this arrangement also solves the problem of overcoming the detrimental effects of gyroscopic forces set up by the heavy flywheel revolving at high speed.

The show is also responsible for the appearance of a rotary internal combustion motor, known as the "American." The rotor is elliptical in shape and is water-cooled, as is also every other part of the motor coming in contact with the hot gases. The explosion chamber is so designed that an explosion takes place on different sides of the rotor alternately, two exhaust outlets being provided.

#### TRYING TO ARRANGE MAXWELL STANLEY RACE.

BOSTON, March 10.—At a meeting to-day at the clubhouse of the Bay State Automobile Association arrangements were partially made for the Maxwell-Stanley challenge race for the Sir Thomas Dewar trophy. Present at the session were Benjamin Briscoe and J. D. Maxwell, and F. E. Stanley and F. O. Stanley, with Alfred Reeves, H. L. Bowden, J. C. Kerrison and Howard Reynolds as disinterested parties. It is proposed to change the conditions of the trophy so as to permit time trials instead of a race, owing to the great danger at the very high rate of speed assured. The event may be made open and Louis Ross may enter a car. As to where the event will take place, there seems to be considerable doubt. It is proposed that a 3-mile special cement course, 80 feet wide, be built by the manufacturers. Mr. Briscoe will learn if the Long Island Motor Parkway will be available for the purpose. Many consider that the parkway would be an ideal course for the contest, and it is quite likely that satisfactory arrangements can be made with the management for its use.

Henry B. Joy, president of the Packard Motor Car Company, and M. J. Budlong, recently appointed assistant manager, were at the show yesterday and to-day they are at Hartford, Conn. Their presence there has revived the rumor that the Packard company may secure the old plant of the Electric Vehicle Company.

#### AUTOISTS ASSEMBLED TO-DAY AT WASHINGTON.

WASHINGTON, D. C., March 12.—Delegates from the various State associations of the American Automobile Association to-day are in Washington, under the leadership of President William H. Hotchkiss and Chairman Charles T. Terry, of the Legislative Board, for the purpose of appearing at the hearing before a sub-committee of the Judiciary Committee of the House of Representatives, to present arguments in favor of the Federal Registration bill, fathered by the national automobile organization. A conference of delegates took place last night at the New Willard Hotel.

#### NEW YORK ASSOCIATION MEETS AT BUFFALO.

BUFFALO, N. Y., March 12.—The New York State Automobile Association of the American Automobile Association is to-day holding its annual meeting in Buffalo, with President Oliver A. Quayle presiding. To-night the delegates will be entertained at dinner at the Buffalo Club by the Automobile Club of Buffalo, and afterwards will visit the automobile show. To-night is society night. There is talk of re-electing President Quayle, whose work as chairman of the legislative committee has been exceptionally successful.

#### FORTIETH CLUB FOR N. Y. STATE ASS'N.

MOUNT VERNON, N. Y., March 10.—The Automobile Club of Mount Vernon, recently formed with a charter membership of fifty, has decided to become affiliated with the State Association of the A. A. A., making the fortieth club in the State of New York connected with the national body. Membership in the club is limited to automobilists in Mount Vernon and vicinity. It is anticipated that the century mark will be reached before June.

#### QUAKERS WANT REASONABLE USE OF GRIPS.

PHILADELPHIA, March 10.—Thursday of last week representatives of the local automobile clubs appeared before the Fairmount Park Commission to protest against the proposed ordinance restricting use of tire chain grips on the park roads. The autoists desire to use grips when the roads are muddy or slippery. The committee reserved its decision.



A Corner of the Second Floor, Where the Display of Accessories Was the Magnet That Attracted Many Visitors.

**THE PERFECTION OF AUTOMOBILE IGNITION.**

(Continued from page 353.)

whether the engine is running 100 or 2,000 revolutions, and it should respond more rapidly at high speeds than at low, but it is apparently impossible to make such a magnetically operated make-and-break in the form of a vibrator. The instrument for demonstrating this advance spark theory consists of a model of a gas engine with its cylinder and piston, connecting rod and crank, but secured to the crank pin is a small pointer *K*, which rotates within a metal ring *L*, clearing it about 1-4 inch. The wires from the secondary of the spark coil are connected to the insulated metal ring *L*, and to the crank and pointer *K*, so that the spark will jump from the pointer *K* to the ring *L* while the engine is in operation. We now set the timer in such a position that in turning over the engine slowly by hand in the direction shown by the dotted-lined crank, we will get a spark when the crank is at the point of maximum compression, as shown in the diagram. If the engine is now speeded to 1,000 r.p.m., without moving the timer, we would find the spark jumping across at *B*, or, in other words, it would be 90 degrees late. This lateness of the spark is entirely due to the lag of the vibrator and the magnetic lag of the iron core, and we must advance the timer an equivalent amount to balance up the two. By varying the speed of the engine, the spark moves from the position *A*<sup>1</sup> to *B*<sup>1</sup>. My object in designing this instrument was to prove that the ignition in a gas engine should take place at the highest point of compression, and it approximately does so when the engine develops greatest power, also that time required to ignite charge is small and requires little advance.

**THE NEW SCHEBLER GASOLINE FILTER.**

Every autoist who has had the slightest experience soon realizes the importance of preventing water, dirt or other foreign matter of whatever nature from reaching the nozzle of the carbureter, and he also realizes, sooner or later, that even the most painstaking precautions are not always sufficient to accomplish this. There must be a last line of defense, and this is to be found at or near the carbureter itself. The method of doing this is clearly illustrated by the

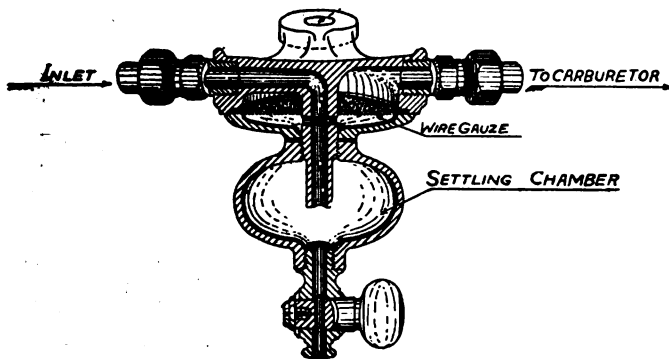

Cross Section of the New Schebler Gasoline Filter.

accompanying line sketch showing the Schebler strainer in cross section. Its arrangement is such that the gasoline cannot reach the carbureter without first passing through the fine mesh screen and gauze.

The bowl is so designed that the heavier particles of dirt and all water will collect there, the drain cock at the bottom permitting their escape. To facilitate the removal of matter that cannot escape through the cock, the bowl is made removable. When the gauze becomes dirty, the bowl and lower half of the entrance chamber may be instantly removed, rendering the screen perfectly accessible. The Schebler strainer is fitted with a bracket for attaching to a support, and should be connected so that the gasoline flows in the direction indicated by the arrows.

**ALLEN-KINGSTON NOT INVOLVED IN FAILURE.**

The New York Car and Trucking Company, of which Orlando F. Thomas was president, is now in the hands of an official receiver. The company was incorporated under the laws of New Jersey, May 5, 1906, with a capital stock of \$2,500,000, its works being at Kingston, N. Y. It succeeded the bankrupt Peckham Company as manufacturers of car trucks and automobiles. Though a portion of the works was devoted to the construction of the Allen-Kingston car, the Allen-Kingston Motor Car Company is financially independent of the bankrupt concern, and, according to the statement of Walter C. Allen, its president, will be in no way affected by the reverse. That portion of the works devoted to automobile construction will be bought from the receivers or a separate factory will be secured.

The assets of the New York Car and Truck Company are declared to be about \$75,000. Among the creditors are: Harry J. Schnell, \$61,500, for loans; Carl Coonley, \$5,000, loans, and Colby M. Chester, \$1,768, for merchandise. Judge Holt has authorized the receiver to continue business twenty days.

**PLAN TO REORGANIZE RELIANCE COMPANY.**

LANSING, MICH., March 2.—It is expected that the plant of the Reliance Motor Car Company of this city, which has now been shut down for some time, will shortly resume operations, as capitalists interested in the Reo and Olds plants have advanced \$100,000 to put the company on its feet again. Victor N. Gurney, of Detroit, has been appointed receiver, pending the reorganization which is now under way. It is reported that all creditors will be paid in full. The company was incorporated in 1904 with a capital of \$400,000. Its officers are: President, Fred. O. Paige; vice-president, J. M. Ulkey; secretary, J. B. Corliss; treasurer and general manager, E. W. Gans; sales-manager, F. L. Loomis; engineer and superintendent, H. A. Wilcox. The company was authorized to issue \$150,000 in bonds, of which \$130,000 were sold. The Union Trust Company was a trustee under the mortgage to secure the bonds and the receiver has been appointed on its petition.

**DARRACQ AUTO COMPANY IN RECEIVER'S HANDS.**

A petition in bankruptcy has been filed against the Darracq Motor Car Company, of 1989 Broadway, incorporated January 12, 1906, with a capital stock of \$100,000, reduced to \$50,000 on April 6, 1906. A few days ago, E. Lamberjack & Co. obtained a judgment against the company for \$2,088 for tires, execution of which was issued by the Sheriff. Judge Holt, of the United States District Court, appointed Lindsay Russell receiver, with a bond of \$50,000. The company has automobiles valued at \$75,000, separate parts and accessories, \$18,000, and machinery and tools valued at several thousand dollars. Liabilities are declared to be \$100,000. G. W. McWilliams was president; C. D. Wilder, treasurer, and Ben Wood, secretary.

**CONCERNING POPE INDIANAPOLIS PLANT.**

INDIANAPOLIS, IND., March 10.—Although it cannot be confirmed, there is a strong rumor that local capitalists are organizing a stock company to take over the Waverly plant of the Pope Motor Car Company.

The rumor connects two men who have been with the local automobile industry since its incipency, as the promoters of the company. However, neither are willing to make a definite statement at this time, until the matter has developed further.

Electric automobiles are manufactured in the local Pope plant exclusively, and it is understood that the new company would push the commercial vehicle end of the business especially.



## BRIEF ITEMS OF NEWS AND TRADE MISCELLANY

An accidental use of the emergency brake put an end to the Franklin non-stop run after the 28-horsepower car had run for 18 days 8 hours 50 minutes. The end of the test came at Cincinnati, after journeys in the States of New York, Ohio, Indiana and Kentucky.

Owing to an error in transcription, the fuel consumption of the 45-horsepower, 7-passenger Lozier in the Long Island economy test was stated as 27.75 gallons of gasoline, instead of 25.75 gallons. Total distance, according to the indicators of a majority of the cars, was 234 miles, which gives an average for the Lozier of over nine miles to the gallon with seven passengers, hood, full touring equipment and spare tires.

An excellent record was made by Continental tires in the recent Ormond-Daytona races. The 100-mile race for the Minneapolis International Championship trophy, the 160-mile event for stock cars, and the 288-mile event for the Automobile Club of America Cup, were all won on Continentals. In this latter event a world's record of 300 miles in 233 minutes 44 seconds was made; the makers feel justly proud of the performance. Many important racing events in Europe for the past year or two have been won on Continentals and a large number of racing cars to be used in America this year are also fitted with them.

Following up its aggressive campaign against manufacturers who have been making and marketing lamps that are colorable imitations of the Rushmore flare front headlights and searchlights, the Rushmore Dynamo Works, Plainfield, N. J., have recently extended their efforts to take in the jobbers and have obtained injunctions against several dealers in New York City within the past week or two. This is in addition to the injunction issued against the Manhattan Lamp Works, the latter having been the defendant in the test case brought to establish the claim in the United States Circuit Court. This injunction has been made permanent.

The announcement of the classes in the hill-climbing competitions to be held in connection with the New York City automobile carnival during the first week in April does not meet with the approval of George W. Bennett, manager of the metropolitan branch of the White Company. There are six events restricted to gasoline cars of various prices, one for steam cars, one for electrics, and one free-for-all, thus limiting the White cars to two events, that for steam cars only, and the free-for-all. Mr. Bennett claims that such a distinction is unfair, and that his cars should be admitted in the price classification, stating that the White cars are in direct competition with gasoline cars of equal price, and that to bar them from the competition is unsportsmanlike.

### RECENT TRADE CHANGES.

The Diamond Rubber Company's branch at Pittsburg, Pa., has been moved to a fine new store specially fitted up for its occupancy at 6122 Center street, East End, that city.

The Morse garage at Lenox, Mass., has been leased to Oscar R. Hutchinson, who will carry on the business of the late

Thomas S. Morse, who established the business. Mr. Hutchinson will handle the Pope line of cars and carry a large line of sundries. Several improvements will be made in the garage and repair shop to handle the steadily increasing business.

### NEW AGENCIES ESTABLISHED.

The Simplex Motor Company, of New York, has opened a Boston salesroom at 173 Huntington avenue, that city.

The Blue Ribbon Auto and Garage Company, Bridgeport, Conn., has been appointed Lozier agent for the section of Fairfield county east of Green's Farms and North Wilton.

The Northern Motor Car Company during the past ten days has placed the following agencies: H. M. Jarboe, Carrollton, Mo.; Bert Nelson, Bennington, Kan.; W. H. Thompson, Junction City, Kan.; Colonial Motor Car Company, Springfield, Mo.; White Garage, Oakland, Cal.

The Hamilton-Kull Company has been formed and begun operations at 1677 Broadway, New York City, as the Eastern distributors for the Aerocar Motor Company of Detroit. Of this company, Douglas Hamilton is treasurer and A. L. Kull is manager. The company is thoroughly equipped to handle the Aerocar throughout the Eastern territory.

### PERSONAL TRADE MENTION.

H. W. Doherty, formerly of the Corbin Motor Vehicle Corporation, has been appointed sales manager of the Cameron Car Company, of Beverly, Mass., and will handle the output of the company's Brockton and Beverly factories.

### NEW YORK SANCTIONS PARADE.

By the granting of permission from the city authorities to use the streets of New York on the evening of April 7 for a monster parade and street exhibition, the organization of the New York Automobile Trade Association's carnival week has taken a step forward. The parade, which is to be one of the main features of a unique carnival, will counter-march on Broadway, above Fifty-ninth street, the judges' stand being located at some point on upper Broadway, in the park strip between east and west divisions of the street. It is at this point also that the press stand will be erected. Full liberty for individual fancy will be given in the decorated section of the parade, and competition will be stimulated by three prizes to the owners of the three best decorated cars in the procession. In addition, a special prize will be awarded to the owner of the most grotesquely decorated car. In this section no marks of identification will be allowed other than prominently displayed uniform numbers. In the dealers' section, decorations will not be allowed, and advertising will only be permitted to a moderate extent. Racing models and commercial vehicles lent by firms employing them in daily service will add to the completeness of the exhibition.

A price classification will be adopted for the hill climb on Thursday, April 9, the prices starting at \$1,000 and less, and running up through six divisions of one thousand dollars to the highest class, selling at more than \$5,000. One class is provided

for steamers at any price, and another for electric automobiles. A free-for-all, racing or stock class, will also be unfettered by any price limit. An early announcement is expected regarding the place of the hill climb, and will be followed by the sending out of entry blanks to possible contestants.

The board of governors of the Automobile Club of America has voted to postpone the regular Tuesday evening club night of carnival week to Saturday evening, April 11, on which occasion a smoker will be given in the new clubhouse on Fifty-fourth street, west of Broadway, to members of the club and the automobile trade, who will participate in the carnival. The carnival committee will make presentations on this evening of the cups, prizes and trophies won during carnival week. This will include the prizes for the best decorated cars in the parade, which will take place Tuesday evening, and the prizes won in the hill climbing contest, which will be held on Thursday.

### SIGNPOSTING OF THE ROAD.

ROCHESTER, N. Y., March 9.—On every public highway entering Rochester, particularly the arteries of automobile travel, there have just been placed a series of signposts similar to the one illustrated. These posts are accurately located, for a distance of twenty-five miles outside of the city, being a mile apart,



and serve not only to test the distance covered, but as a guide to the best roads entering Rochester and how to follow them.

They were placed by the Duffy-McInnerney Company, both Mr. McInnerney, the general manager, and Mr. Campbell, the advertising manager, being enthusiastic motorists. If some store in each large city would "go and do likewise" there would soon be a continuous chain of mile posts all the way across the country.

### NEW TRADE PUBLICATIONS.

Catalogue D from the Rapid Motor Vehicle Company, Pontiac, Mich., describes the different types of model D rapid delivery vehicle. The catalogue, which is an excellent piece of typographical work, contains illustrations in black and in colors of mechanical features of the "Rapid" and examples of types of bodies generally used for commercial work.

INFORMATION FOR AUTO USERS

**Motor Cycle Lamps and Generators.**—The Motor Car Equipment Company, 55 Warren street, New York, among its numerous specialties are making an unusual showing of imported motorcycle

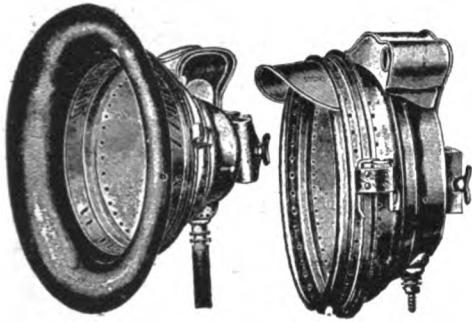

MOTOR CAR EQUIPMENT CO. HEADLIGHTS.

headlights and generators. They are designed particularly for use on bicycles and motorcycles and are very light and compact so as to be conveniently carried on the machine. The lamps are of the flare front type, finished in nickel and have nickel trimmings, so that they make a very attractive appearance. The generators are very simple and compact and are designed to have a capacity of 8 to 10 hours burning with the 1-4-inch burner used in the lamps. Three sizes of lamps and generators are made, two of the flare-front type and one an attractive oval headlight model, the generators holding 1-2, 3-4 and 1 1-3 pounds of carbide respectively.



M. C. E. CO. GENERATOR.

**Standard Automatic Lubricator.**—The Standard Automatic Lubricator Company, 367-369 Ellicott street, Buffalo, N. Y., manufacture a very extensive line

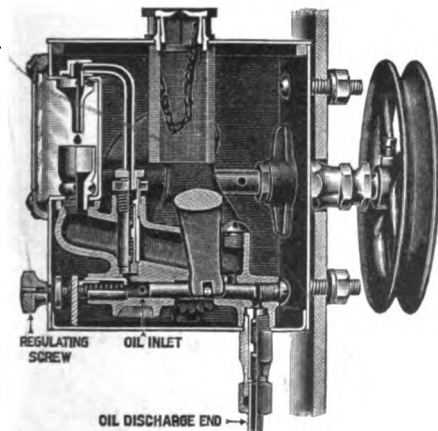

SECTIONAL VIEW STANDARD LUBRICATOR.

of mechanical oilers particularly designed for automobile and motor boat use. They are made with six different sizes of oil reservoirs, ranging from 2 to 12

pints capacity, and from one to 18 individual feeds. These oilers are designed to be placed either on the dash or under the hood of the car and are so made that they can be driven from the right or left-hand side, either end, the bottom or front of tank, thus making them universally applicable, which is a great advantage where room is limited as under the bonnet of an automobile. The sight feed and adjustments are placed on the front wall of the reservoir, thus permitting the removal of the cover without disturbing any of the pumping mechanism. The oil is drawn into a double-acting pump by the backward stroke of the intake plunger through a small port which is incased in a strainer to prevent the entrance of any foreign matter. On the forward stroke, the plunger closes the port and imprisons the oil in the cylinder, forcing the regulating piston back until it rests against the adjustment stop in regulator screw, then the pressure raises the double ball checks and the amount regulated flows from the drip nozzle.

**"The Little Steersman."**—This is a little device that is being manufactured and placed on the market by the Abrams-Mason Company, Chatham, New York, and it is one of those things that hundreds of drivers have been on the lookout for. It consists of a double helical spring designed to be attached to the connecting link of the steering gear and to the forward spring clips at the axle and is intended to relieve the driver of

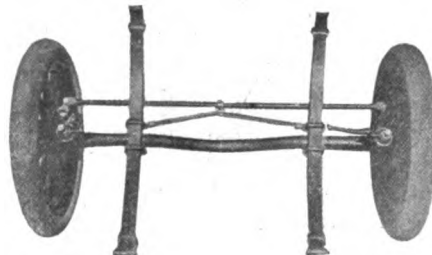

STEERSMAN DEVICE APPLIED TO CAR.

all physical strain in keeping the wheels in the straight ahead position when traveling over rough and uncertain roads. The tension is so regulated that no extra exertion is required to turn corners, and yet is sufficient to keep the car straight even under extremely adverse conditions, such as the bursting of a front tire when running at speed.

**Decarbonizer.**—This is an oily substance mixed with chemicals designed to combine with the carbon, and with the aid of the combustion taking place in the cylinder, to volatilize it, in which it readily passes out the exhaust as dense smoke, leaving the cylinder, piston and rings in a perfectly lubricated condition, free from carbon and resinous substances. The process requires about 15 minutes for its completion and the cost is merely nominal. It is guaranteed by the makers to be absolutely harmless when used in connection with gas or gasoline engines. The engine should be hot before using the Decarbonizer, and it is preferable to run it comparatively dry for a few minutes just prior to using it. The General Accumulator & Battery Co., Milwaukee, Wis., are the makers.

**Two-Spot Spark Plug.**—"Two-Spot by name, two-spot by nature and each spot a concentration of electrical intensity, assuring complete, positive and rapid ignition," say the makers of this new plug in describing it. As will be evident from the accompanying illustration showing one of these plugs complete, its chief feature consists of the exclusive design of the electrodes which permits the plug to produce two distinct sparks every time the current passes and which increases its factor of reliability by 100 per cent., as but one of the sparks is necessary to ignite the charge, and it is an extremely rare probability for both of the gaps to become short-circuited or sooted up at the same time—this also being prevented by their special construction, which tends to keep them clean and free from oil and soot. This new plug is being made and marketed by the Two-Spot Manufacturing Company, Canastota, N. Y., and is already meeting with considerable favor, especially for marine use.

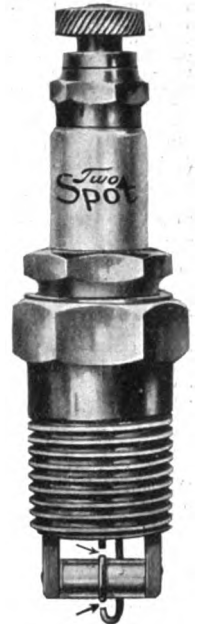

TWO-SPOT SPARK PLUG.

**Mossberg Display Stand.**—How to attractively display small tools is a problem with the dealer, and to overcome this the Frank Mossberg Company, Attleboro, Mass., have come to the dealer's aid by bringing out a special display



MOSSBERG'S WRENCH DISPLAY STAND.

stand for effectively showing samples of their extensive line of wrenches, as will be seen by the accompanying illustration. The stand is capable of holding 20 different types and sizes of wrenches. It stands 17 inches in height and has a base 7 inches in diameter. It is finished in bright nickel plate and when mounted full of wrenches makes an attractive counter or window display.

INDEX TO ADVERTISERS

Table listing various automobile-related companies and their page numbers, including Abrams-Mason Co., Acetylene Gas Illuminating Co., Acme Motor Car Co., Adams Co., Add-Wear Auto Tire Sleeve Co., Aerocar Motor Co., Ajax-Grieb Rubber Co., Almy Water Tube Boiler Co., American Ball Bearing Co., Am. Brass & Alum. Works., American Bronze Co., Amer. Motor Car Sales Co., American Motor Truck Co., Anderson Forge & Machine Co., Apperson Bros. Automobile Co., Ashtabula Bow Socket Co., Ashton Valve Co., Atlas Motor Car Co., Auburn Automobile Co., Audel & Co., Theo., Aurora Motor Works., Austin Automobile Co., Auto Car Equipment Co., Auto Pump Co., Autocar Co., Automobile Supply Co., Automobile Supply Mfg. Co., Automobile Utilities Co., Auto-Shine Co., Auxiliary Spring & Vent-Button Co., Avery Portable Lighting Co., Baldwin Chain & Mfg. Co., Bartholomew Co., Barnett Drop Forging Co., Bay State Stamping Co., Beaver Mfg. Co., Behen-Faught Motor Car Equipment Co., Bellfuss Motor Co., Beloit Supply Co., Black Mfg. Co., Blasier Mfg. Co., M. E., Blomstrom Mfg. Co., Boker & Co., H., Bosch, Robert., Boston Auto Gage Co., Bowser & Co., S. F., Boyle & Co., John., Brennan Motor Mfg. Co., Brown Co., Brown, Wm. W., Brownell Motor Co., F. A., Brush Runabout Co., Buckeye Jack Mfg. Co., Buckeye Mfg. Co., Buffalo Carburetor Co., Bullard Automatic Wrench Co., Buob & Scheu., Byrne-Kingston Co., Cadillac Motor Car Co., Cameron Car Co., Canton Drop Forge & Mfg. Co., Capitol Auto Co., Carr, F. S., Chadwick Engineering Works., Champion Co., A., Chandlee & Chandlee., Case & Hechinger., Chicago & Alton Ry., Clark, E. S., Cleanola Co., Cleveland Motor Car Co., Cleveland-Canton Spring Co., Coas Wrench Co., Colgan Co., J. W., Columbia Lubricants Co., Comptoir d'Innovations pour Automobiles., Conn. Tel. & Elec. Co., Continental Caoutchouc Co., Continental Motor Mfg. Co., Corbin Motor Vehicle Corp., Cornish-Friedburg Motor Car., Correspondence School of Motor Car Practice., Cotta, Chas., Cowles & Co., C., Crown Battery Co., Crown Soap Co., Cullman Wheel Co., Cummer Co., Jos. W., De Luxe Motor Car Co., Diamond Chain & Mfg. Co., Diamond Rubber Co., Dietz Co., R. E., Dixon Crucible Co., Joseph., Dorris Motor Co., Dover Co., Geo. W., Dow Portable Electric Co., Duff Mfg. Co., Duplex Co., Earl Motor Car Co., Echo Horn Co., Eclipse Machine Co., Eco Mfg. Co., Edmunds & Jones Mfg. Co., Eldredge Electric Mfg. Co., Elite Mfg. Co., Ellsworth, J. M., Elmore Mfg. Co., Empire Automobile Tire Co., Excelsior Supply Co., Firestone Tire & Rubber Co., Fisk Rubber Co., Forest City Motor Car Co., Franklin Mfg. Co., H. H., Fry, T. C. & W. L., G & J Tire Co., Gabriel Horn Mfg. Co., Garford Motor Car Co., Gearless Transmission Co., Geisler Bros., Gemmer Mfg. Co., General Accumulator & Battery Co., Gibney & Bros., Jas. L., Goldberg Motor Car Devices Mfg. Co., Goodrich Co., B. F., Grout Bros. Auto Co., Ham Mfg. Co., C. T., Hardy Co., The R. E., Harris Oil Co., A. W., Hartford Rubber Works Co., Hartford Suspension Co., Hatcher Auto Parts Co., Hatfield Motor Vehicle Co., Haynes Automobile Co., Healy Leather Tire Co., Hedgeland Mfg. Co., Heinze Electric Co., Heitger Carburetor Co., Hercules Auto Specialty Co., Herz & Co., Hess-Bright Co., Hicks Speed Indicator Co., Hoffecker Co., Hoffman, Geo. W., Holt & Beebee., Holley Bros. Co., Holsman Automobile Co., Hotel Fredonia., Hotel Piney Woods Inn., Hotel Rudolph., Hotel Tower., Hotel Westminster., Howard Motor Works., Hoyt Electrical Ins. Co., Imperial Motor Car Co., Indestructible Steel Wheel Co., Jackson Automobile Co., Jeannin Auto & Mfg. Co., Jeffery & Co., Thos. B., Jencick Motor Mfg. Co., Johnson Sporting Goods Co., I. 57, Jones Speedometer., Jones, W. H., K. W. Ignition Co., Kellom Co., Chas. F., Kent Mfg. Works., A., Kimball Tire Case Co., King Top Mfg. Co., Kinsey Mfg. Co., Kinsler Bennett Co., Kissell Motor Car Co., Konigslow, Otto., Koontz & Co., J., Lansing-Mahon Press., Lavalette & Co., Lavigne Mfg. Co., Lear Automobile Co., Oscar., Leather Tire Goods Co., Limousine Carriage Mfg. Co., Lipman Mfg. Co., Lobe Pump Co., Locke & Co., Lockwood Bros., Locomobile Co., Logan Construction Co., London Auto Supply Co., Long Mfg. Co., Manhattan Storage Co., Masury & Son, John W., Mathewson Motor Car Co., Maxwell-Briscoe Motor Co., Mayo Radiator Co., McCord & Co., Merchant & Evans Co., Merritt & Co., Metzger, C. A., Michelin Tire Co., Midgley Mfg. Co., Midland Motor Car Co., Miller Bros., Miller, Chas. E., Miller & Starr., Mitchell Motor Car Co., Model Automobile Co., Moline Automobile Co., Mora Motor Car Co., Mora Motor Car Co., Cover., Morgan & Wright., Mosler & Co., A. R., Moss Photo Engraving Co., Motz Clincher Tire & Rub. Co., Mound Tool & Scraper Co., Mutty Co., L. J., National Auto Accessories Co., National Motor Vehicle Co., Neustadt Auto & Supply Co., Never-Miss Spark Plug Co., New England Motor Co., N. Y. Gear Works., N. Y. Sporting Goods Co., Nichols & Co., D. P., Nordyke & Marmon Co., Northway Motor & Mfg. Co., Nuttall Co., R. D., Oakland Motor Car Co., Ofeldt & Sons., Olds Motor Car Co., Owen & Co., R. M., Pacific Tucking & Mfg. Co., Packard Electric Co., Packard Motor Car Co., Palmer & Singer Mfg. Co., Pantasote Co., Parish & Bingham., Parker, Stearns & Co., Peerless Motor Car Co., Penn. Auto Motor Co., Perfection Grease Co., Perfection Spring Co., Peugeot Freres., Pfanstiehl Elec. Laboratory., Pirome Hide Co., Pierce Engine Co., Pioneer Brass Works., Pirelli & Co., Pittsfield Spark Coil Co., Precision Appliance Co., Prest-O-Lite Co., Progressive Mfg. Co., Quinby Co., J. M., Raimel & Co., Rainier Co., Rajah Auto Supply Co., Randall-Falchney Co., Rapid Motor Vehicle Co., Reeves Pulley Co., Remy Electric Co., Renault Freres., Cover., Republic Rubber Co., Richardson Engineering Co., Robert Instrument Co., Ross Gear & Tool Co., Rubay, Leon., Royal Equipment Co., 54 and Cover., Rushmore Dynamo Works., Salisbury Wheel & Mfg. Co., Samson Leather Tire Co., Seaboard Florida Limited., Selden Motor Vehicle Co., Shaler Co., C. A., Shawver Co., Smith Co., A. O., Smith Mfg. Co., R. H., Smith & Son, S., Spacke Machine Co., F. W., Spare Motor Wheel of Am., Speed Changing Pulley Co., Spicer Universal Joint Mfg. Co., Splittdorf, C. F., Sprague Umbrella Co., Standard Automatic Lub. Co., Standard Battery Connection Co., Standard Co., Standard Connecting Rod Co., Standard Welding Co., Steam Carriage Boiler Co., Stearns Co., F. B., Stevens-Duryea Co., Streit Machine Co., Studebaker Automobile Co., Success Auto Buggy Co., Supplementary Spiral Spring., Swinehart Clincher Tire Co., Syracuse Aluminum & Bronze Co., Thomas Motor Co., E. R., Thompson Sons Co., J. P., Timken Roller Bearing Axle Co., Tincher Motor Car Co., Torbensen Motor Car Co., Tray Plate Battery Co., Trebert Gas Engine Co., Troy Carriage Sunshade Co., Tucker, C. F., Uncas Specialty Co., U. S. Fastener Co., Veeder Mfg. Co., Vehicle Specialty Corporation., Walker Mfg. Co., E. C., Warner Instrument Co., Warner Pole & Top Co., Watt-Detroit Carburetor Co., Waukesha Motor Co., Wayne Automobile Co., Weed Chain Tire Grip Co., Welch Motor Car Co., Western Motor Co., Weston Elec. Instrument Co., Wheeler & Schebler., White Co., The., White & Bagley Co., Cover., Whitmer & Remy., Whitney Mfg. Co., Winton Motor Carriage Co., Winterbe Igniter Co., Wright Cooler & Hood Co., Wyman & Gordon Co., York Motor Car Co.

Advertisement for J. W. Colgan Co. featuring various automobile brands and logos such as Mitchell, Emore, Cadillac, Rambler, National, Acme, Columbia, Pullman, Haynes, and others. The text includes 'MONOGRAMS AND NAME PLATES', 'ALL STYLES', 'ALL SIZES', and 'SUDBURY BUILDING - BOSTON, MASS.'.

# THE AUTOMOBILE

## PREPARING FOR SAVANNAH'S GREAT MEET

SAVANNAH, GA., March 17.—Savannah is on the eve of its great auto races, which bid fair to inaugurate in the South a new era in the vogue of the motor-driven vehicle. The automobilists of the North and West are lending their brethren of the South a helping hand in the conduct of what promises to be a series of memorable contests—in fact, the inaugural of a form of motor-car speed competition that will give to a manufacturer his best chance for the demonstration of the speed qualities of his normal product, and to the public a most convincing exploitation of the various makes of stock cars entered.

For the promotion of the races and the truly masterly attention to the details of preparation, and the unstinted liberality in providing an unequalled course for racing, as well as everything for the convenience and safety of both contestants and spectators, practically undivided credit is due the members of the Savannah Automobile Club and of the citizens' committee of the semi-tropical Georgia city. What the experience of the A. A. A. racing and technical boards members and their chosen officials will add to the success of the meet will be demonstrated by the results at the conclusion of the program.

The tom-tomming scribes of the press have not let the general and motoring public forget that there was no Vanderbilt Cup

race last year, nor that the rules for stock car competition roughly outlined by the committee of makers last summer still lay upon the shelf.

The motoring Savannahans believed that they had a fit course, were willing to spend the money to promote the races and, best of all, were able to guarantee the military and police protection demanded by the Racing Board as the *sine qua non* of their cooperation in their promotion of a really national competition. The A. A. A. and the S. A. C. wanted a race, and they got together, and that was all there was to it. The result is that the perfection of the preliminaries promises the best course and the best run races in the history of motoring in this country.

Again, let the credit be given to the Savannahans. They have proven themselves true sportsmen. They have not been out for the almighty dollar. Their first thought has been the success of the race. They have spent their money like true Southern thoroughbreds, and "D——n the expense, Sah!"

These Georgians have higher ambitions, though, in race promotion. Their aim is to demonstrate to the American Automobile Association that they have a more than merely available course for the Vanderbilt Cup race, and that they are capable of affording adequate facilities and preparations for it. They



Pooler in Isotta-Fraschini Returns from Practice Run and Tells Officials of Fine Condition of Course.





Bridge for Trolley Passengers Over the Course.

will surely have to be considered in the award of the course when it comes up for official consideration.

It can be truly said that never have the racing autoists of either continent had supplied them the equal of this 18-mile circuit as a long-distance race course. It is level. It is smooth. It has room for two cars to pass at its narrowest, and for several to drive abreast at its broadest, point. In the run through Thunderbolt and the Isle of Hope, it presents a corkscrew of turns that will well test the skill of the best drivers. It lacks hills utterly. On its stretches, it admits of the ultimate of speed and a pace of almost a mile a minute around its turns. Sustained maximum speed will go far to test engine endurance by way of atoning for the lack of strain hill-climbing would afford. The Savannahans have practically built a race course. They have made sharp turns easy by gradually rounding and elaborately banking them at places even with cement. In easing the corners, they have cut ruthlessly through private property and even front yards, but with the ready acquiescence of the hospitable and sportsmanlike owners. They have rebuilt bridges, so that the planks shall run longitudinally. They have leveled the railroad crossings. They have built bridges across the course for the transfer of trolley passengers. They have refined the entire surface of the circuit. They have established fifteen telephone stations. They have erected a grandstand with 5,000 seats and 65 boxes; provided 50 parking spaces for motor cars; have erected separate judges' and press stands; have shut off the homestretch with an impenetrable wire barrier, and their steamship companies have given autoists such cheap rates for transportation of their cars that a New Yorker may take his machine to Savannah and back for \$15. They have not sought to make a gold mine of their grandstand. Boxes, seating six, are sold for the two days for \$35; seats, with backs, for the two days, for \$2.50, and bench seats at \$1 per day.



One of the Signs that Indicates a Turn Coming.

N. H. Van Sicklen, of Chicago, chairman of the A. A. A. Technical Board, has been here for three weeks, assisting the local committee in its preparations for the race. The vice-chairman of the Technical Board reached here Sunday morning. These two began at once their task of examining the cars as to their compliance with the stock car rules. Fred J. Wagner, official A. A. A. starter, arrived here on Thursday to familiarize himself with the course and the details of the conduct of the race.

On Sunday afternoon, there came from New York, Chairman Jefferson deMont Thompson, Vice-Chairman Frank C. Webb, Lewis R. Speare, Stanford L. Haynes and A. G. Batchelder of the Racing Board, and National Secretary F. H. Elliott. They immediately got in touch with the local committee, going over the course in the afternoon and holding a joint meeting that evening. A considerable contingent of newspaper men from New York and Philadelphia was already on hand.



Dangerous Turn on Isle of Hope that is Banked.

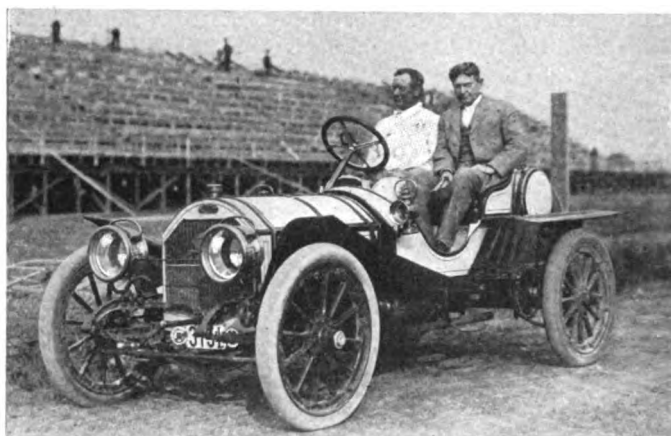

Chairman N. H. VanSicklen, A. A. A. Technical Board, and President Battey, Savannah Automobile Club.

The 180-mile race for cars under 375 cubic inches piston displacement will be started at 10 o'clock Wednesday morning. The candidates on hand are the Automotor Company's 50-horsepower Pennsylvania, L. J. Zendell, driver; the E. R. Thomas 40-horsepower Thomas-Detroit, B. J. May, driver; Apperson 24-horsepower, Herbert Lytle, driver, and a second 40-horsepower Thomas-Detroit, S. B. Lorrimer, driver.

The same day, at two in the afternoon, the 180-mile race for cars over 575 cubic inches piston displacement will be run. But two of the five entrants are here. George Salzman will drive a six-cylinder Thomas Flyer of 70 horsepower, entered by J. F. Kiser, an Atlanta amateur, and Frank Leland, the 45-90-horsepower six-cylinder Stearns, nominated by E. H. Inman, of Atlanta. It is expected that the 60-horsepower Matheson, entered by its maker, which J. B. Ryall will drive, will get here,

but small hope is entertained of the appearance of either the 50-horsepower Gearless, entered by the Gearless Transmission Company, of Rochester, or the 50-horsepower Austin.

The big 360-mile race for the Savannah challenge cup will be started at 10 o'clock Thursday morning. All eight candidates are here. They and their numbers are:

1. Apperson Jackrabbit, 50-h.p.; Herbert Lytle; Apperson Bros.
2. Isotta Fraschini, 50-h.p.; Louis Strang; J. H. Tyson.
3. American, 50-h.p.; Fred Tone; American Motor Car Co.
4. Lozier, 45-h.p.; Harry Michener; H. A. Lozier.
5. Apperson Jackrabbit, 50-h.p.; W. R. McCulla, Apperson Bros.
6. Isotta Fraschini, 50h.p.; Al. Poole; Isotta Fraschini Import Co.
7. Stearns 4-cylinder, 30-60-h.p.; Frank Leland; Ross Guerrard.
8. Acme 6-cylinder, 45-h.p.; M. A. Neusteter; Acme Motor Car Co.

Anent the drawing for numbers for this race, there hangs a tale. Edgar Apperson claimed that he had made his entries, and that they were accepted with the understanding that they should be started, respectively, first and last. Though this was clearly against all precedent and contrary to the conditions named on the entry blanks, the other entrants consented, in view of the Apperson's having made the initial entries to the meet to one of their cars starting first, but refused flatly to permit the other to wind up the procession.

In the light runabout class, those with piston displacement of less than 375 cubic inches, excellent sport is looked for. In this are two Thomas-Detroit roadsters, colored blue and designated the "Blue Birds"; a Pennsylvania, an Apperson, a Premier and a Cleveland. Of this group, the Pennsylvania is very fast, having been credited with being timed at as high as a 72-mile gait on the grand stretch.

In the 360-mile race, the eight starters are all on hand, and are doing daily work on the course. In checking over all of these cars, the Technical Board took the measure of the wheelbase, wheels, tires, cylinders, radiators, brakes, frame and springs, and inspected the carburetion, ignition, lubrication, cooling and other parts. Calipers and straight edges were in constant use.

Chairman N. H. Van Sicklen and Vice-Chairman David Beecroft were busy all day Monday inspecting the many competing cars and checking over the various measurements of them, to insure that nothing but stock constructions were allowed. In this little trouble was met with, the majority of the cars carrying every ear mark of the stock machine. Not a little care was taken on the two Isotta Fraschini machines, that have every line of a racing machine. However, the catalogues from Italy show them to be of stock lines, the company having brought out a special line of fast roadster cars.

The six-cylinder Thomas was compelled to take off a 29-gallon cylindrical gasoline tank that was mounted crosswise behind the seat, and to use instead the regulation tank under the seat. The Lozier was ordered to use but one of its 5-gallon oil tanks carried lengthwise on the chassis; one of the Thomas Forty machines had its spring wrapped, which wrapping was removed, but otherwise nothing out of the regular was met with. It is most commendable to think that the makers have taken stock jobs off the shipping room floor and have not tried to win a victory by unfair means.

In the race for cars with a piston displacement of over 575 cubic inches, the probable starters are Thomas and Stearns, the Austin, Matheson, and Gearless not having arrived. The Thomas will start first, and Leland with the Stearns will follow a minute later. Both of these cars are speedy and the result of their meeting is awaited with great interest.

#### Apperson and Thomas Win First Day's Events.

SAVANNAH, GA., March 18.—Herbert Lytle, driving the 24-horsepower Apperson stock runabout, crossed the line a winner in the 180-mile race for four-cylinder stock runabouts having a maximum piston displacement of 375 cubic inches, which was the opening event of the meet. His time was 3:35:41, the last lap being made in 21:19, while his average speed was about 53 miles an hour. S. B. Lorrimer, in the Thomas Detroit 40-horsepower *Bluebird*, was called off at the end of the ninth lap, having covered 162 miles in 3:36:58, a combination of tire and carbureter

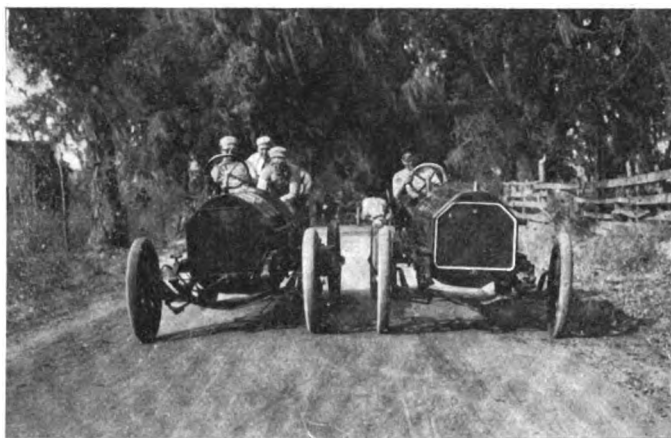

Two Six-cylinder Candidates—Stearns and Thomas.

trouble having caused the delay and the heavy loss of time.

Beautiful weather was vouchsafed for the curtain-raiser and fully 2,000 spectators occupied the grandstand, which was draped with the national colors and the Three A's banner. The race for runabouts, which was first on the program, originally had four entries, but just before the start word came that the Thomas Detroit, which R. J. May was to drive, had blown out

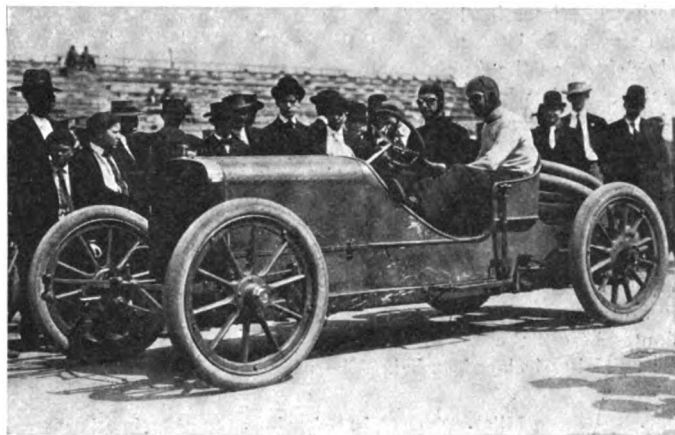

The American Entry, with Driver Tone at Wheel.

a cylinder head. The trio that started was composed of the 50-horsepower Pennsylvania, driven by L. J. Zengell, which was sent away promptly at 10 o'clock; the Apperson Brothers' 24-horsepower Apperson, driven by Herbert Lytle, which got away at 10:06, and the E. R. Thomas Detroit Company's 40-horsepower Thomas, driven by S. D. Lorrimer, that crossed the line at 10:10. All of the cars got away without hindrance.



Pilot Michener at the Wheel of the Lozier.

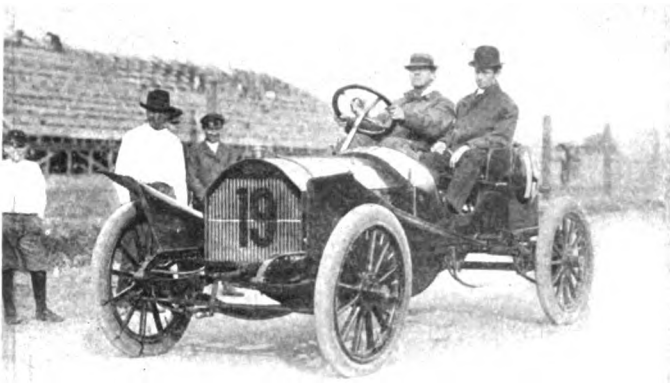

Mr. Apperson and Secretary Solomon, Savannah A. C.

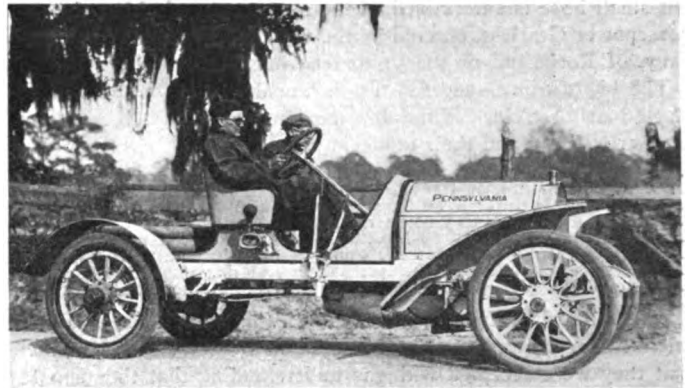

The Pennsylvania Entry, with Driver Tenck in Command.

The Pennsylvania was looked upon as a general favorite and its performance on the first round verified this opinion, as it completed the lap in 18:54, the Apperson following in 20:29, and the Thomas Detroit in 23:45, actual time. These figures had scarcely been posted when it was announced that the Pennsylvania was out of the race with a broken axle. It was learned later that the trouble lay in the clutch. Carbureter troubles soon began to delay the Thomas, and the Apperson gained steadily, passing Lorrimer in the fifth lap, then stopping for gasoline. A stop was made later to change the spark plugs, these being the only delays, as the Apperson was fortunate enough to encounter no tire trouble whatever.

In the third lap the Thomas lost a tire, so that when the Apperson again entered the running the cars were soon close together and made an exciting race of it, being less than two furlongs apart until the end of the eighth lap, when Lorrimer stopped in front of the grandstand to make carbureter adjustments, losing four minutes. From this point on it was a run-away for the Apperson. Lytle was wildly cheered as he entered the ninth lap, and was given an ovation at the finish, just a few minutes before the Thomas ended its ninth round, and the race was officially declared ended. The progress of the race was as follows:

Laps.	Miles.	Lytle's Time.	Lorrimer's Time.
1	18	20:29	23:45
2	36	40:56	48:06
3	54	1:01:16	1:14:11
4	72	1:21:48	1:41:06
5	90	1:48:30	2:05:03
6	108	2:09:02	2:25:05
7	126	2:29:22	2:49:38
8	144	2:53:28	3:14:47
9	162	3:14:22	3:36:58
10	180	3:35:41	

The running of the Apperson was most consistent, varying between 20 and 21 minutes per round, except on the two rounds in which its stops were made.

Two six-cylinder cars faced the starter in the 180-mile race

for cars of over 575 cubic inches piston displacement—a 70-horsepower Thomas, entered by J. F. Kiser, of Atlanta, and driven by George Salzman, and a 45-90-horsepower Stearns, nominated by E. H. Inman, of Atlanta, and piloted by Frank Leland. It was a splendid race at the start, arousing great enthusiasm. The Stearns completed the first 18-mile circuit in 16:55 and the Thomas in 17:35. On the second round the connecting rod of the Stearns broke, forcing the piston through the crankcase and putting it out of the race.

### CADILLAC WON FLORIDA ROAD RACE.

MIAMI, FLA., March 14.—Of the four starters in the road race from Jacksonville, there were but two survivors at the finish. Dr. W. M. Stimson, of Jacksonville, driving a single-cylinder, 10-horsepower Cadillac runabout was the only contestant to finish the 372-mile route laid out by the Cleveland *Pathfinder* in the five days called for by the conditions. A 1905 24-horsepower Peerless, which was chartered to carry the newspaper men and was driven by C. F. Wheeler, arrived here at 4:30 this morning and was awarded second place. Claude Nolan's 10-horsepower, single-cylinder Cadillac runabout was put out of the race yesterday by a broken axle when only 20 miles from here, while Dr. J. H. Pittman, driving a 20-horsepower Buick, gave up at St.

The winner was the only car to get through without a serious mishap to delay it, making the 85-mile run to Ormond in 8:25; the 75 mile stretch to Rock Ledge in 7:28, and a like distance to Fort Pierce in but two minutes more, or 7:30. The 68-mile run to Palm Beach was covered in 10:35, and the remaining 70 miles to Miami in about 4 hours. The Peerless, however, made the 124-mile run from St. Augustine to Rock Ledge in 1 day, 8 hours, 50 minutes, making a new Florida record. It was bogged in a forest near Jupiter for 16 hours the next day and then broke a connecting rod between Palm Beach and Miami.



Driver Price Trying Out His Acme on a Smooth Stretch.

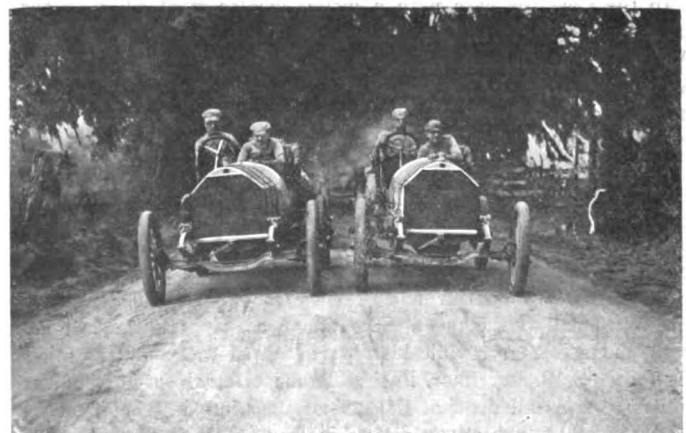

Detroit Thomas Candidates, with Pilots May and Light.

## AERONAUTS PROPHECY THE FUTURE OF FLYING

AT their second annual banquet, which was held at the St. Regis Hotel on Saturday evening last, the members of the Aero Club of America were optimistic regarding the future of aeronautical science—in fact, they were confident that its day is already at hand, and that developments will now follow rapidly upon the heels of one another. So rapidly, in fact, that one would hardly be safe in predicting from day to day what will be the outcome of progress a year hence. But the men who know, and they were the ones who spoke, foresee the beginning of an era of aerial navies of both commerce and war within a few years from the present day, and that is thought certain.

"The day is at hand when the balloon is to be supplanted by practical aerial craft. I believe that within the next six months one of our members will produce a dirigible that will astound the world. The opportunity has been provided by the Government, and success, I am confident, will follow. Heretofore, France has led us in this, as with the automobile, but now, I confidently believe, we shall lead the world.

"That's one cup that has gone abroad," continued Mr. Bishop, referring to the victory of the *Pommern* last fall, "but we pledge ourselves that we are going over there and bring it back. We now hope to form all the aero clubs in this country into a federa-



Many Notable Men, Pioneers in the Field of Inventive Genius, Attended the Aero Club of America's Second Annual Banquet.

"We have now truly entered upon the age of the flying-machine," said Alexander Graham Bell, the veteran of telephone fame, and one of the chief speakers of the evening. "We do not have to produce a heavier than air machine. That has been accomplished. We merely have to improve and perfect that machine just as we did with the automobile. And a short ten years ago the automobile that could encompass the distance of a few blocks was hailed as a marvelous piece of mechanism. Now the automobile can traverse a continent. Its history will be reflected in the perfection of the aerial ship."

Cortland Field Bishop, president of the Aero Club of America, and many of the members of the club, enthusiastically applauded Professor Bell's statements, and several of them, among whom were Hudson Maxim, the inventor of smokeless powder; Major George O. Squier and Lieutenant Frank P. Lahm, of the Signal Corps of the United States Army, spoke in a similarly optimistic vein. "Aeronautics is now recognized as an exact science," was President Bishop's text, "and it cannot be denied that this science is about to give the world a new aspect," he asserted.

tion, which, setting aside every attempt at the mercenary, will aim solely to work for the advancement of aeronautics as a sport and a science. And this result we intend to accomplish."

He was followed by Mr. Maxim, who was of the opinion that an aerial navy, far from forming an element of unspeakable slaughter, would be one of the most powerful incentives to peace. "The flying machine has become an actuality," he said. "All that remains to be done is to perfect already existing means and apparatus in order to complete the conquest of the air. The application of aerial craft to war cannot be doubted. Their utilization as a war machine will probably give to aeronautics its strongest stimulant. Some terrible things have been predicted for the flying machine as a war engine. Many a sanguine inventor has said that with the advent of his flying machine, battleships, coast fortifications and cities could be destroyed by dropping dynamite from the air. It is comforting to know that no very great loss of life or property would result from this cause, for the reason that dynamite requires confinement to work very wide destruction. Half a ton of dynamite dropped



upon the four-inch deck of a battleship might kill a few men, wreck some of the superstructure and dent the deck a bit, but the destruction would not be widespread and the crew below would be uninjured.

"But a flying-machine will have great use for scouting purposes," continued Mr. Maxim. "The enemy, however, will have his aerial scouts out, too, and there will be many a tilt in the air. Then it will be that speed will count for much, for the machine able to fly highest and fastest will hold the others at its mercy. These aerial craft will serve to maintain the peace of the world."

Professor Willis S. Moore, chief of the United States Weather Bureau, described experiments now under way to procure accurate information regarding the upper strata of the air. "We have sent up our instruments to a height of four miles and more," he said, "and in time we expect to have them ascend at least six miles. At that altitude, we believe we will find that the air conditions remain unchanged throughout each day." Because of the depressed temperature to be found at high altitudes, Mr. Moore thought that buildings of the future may reach heights

of 1,000 feet and have summer hotels on the roofs, where heat sufferers may find relief by ascending, either in elevators or aerial craft, and dwell at some length upon this possible development of the not very distant future.

Major Squier and Lieutenant Lahm contented themselves with tracing the creation of the aeronautic division of the War Department, and outlining the steps which led to the placing of contracts for dirigible machines, the first of the American Government's aerial fleet, the pioneer machine of which will be constructed by Captain Thomas S. Baldwin. McCready Sikes, J. W. Kearney, secretary of the Aero Club of St. Louis, and Johnson Sherrick, president of the Aero Club of Ohio, also spoke briefly. The chief feature of the decorations was a miniature balloon, complete in every detail, which was suspended over the table. Among those present were: Robert W. Chambers, Augustus T. Post, Peter Cooper Hewitt, Arthur Iselen, Ernesto G. Fabbri, Lieutenant Maxwell Murray, Lieutenant T. Selfridge, A. Leo Stevens, Albert C. Triaca, R. Stuyvesant Pierrepont, William E. Whitehouse and James W. Osborne.

## FEATURES OF AMERICAN RACER FOR GRAND PRIX

**T**HOUGH not in every detail a stock chassis, the Thomas Flyer which Montague Roberts will drive as the sole American representative in the French Grand Prix July 7 is a much nearer approach to the regular factory output than the majority of racers. The French Derby calls for cars of not more than 6.1 inches bore for four-cylinder engines, and of not less than 2,425 pounds total weight; in all other features constructors are absolutely unfettered. The standard Thomas car, known as the 4-60 Flyer, has a four-cylinder motor of 5 1-2 bore by 5 1-2-inch stroke, obviously too small to compete against the 6.1 by 7.08 foreign racers. On the standard engine base, however, it will be possible to fit cylinders of the maximum bore of 6.1 inches, declares F. P. Nehrbas, superintendent of the E. R. Thomas Company, and this will be the only essential in which the racer will differ from the standard 1908 runabout.

In all probability the engine stroke will not be increased, for this could not be done without altering the entire motor design, and the desire of the factory is to remain as close to stock models as possible. Valve arrangements will be identical with those of the 60-horsepower runabout, inlet and exhaust valves being in pockets on opposite sides, operated by separate camshafts. Bosch high tension magneto will be fitted, with possibly an Atwater-Kent spark generator for use in starting up. Lubrication and engine cooling remain unchanged, the former consisting of mechanical six-sight feed oiler and the other of a centrifugal pump, cellular radiator and two fans. Carbureter

will be the Thomas automatic water-jacketed type with auxiliary inlet, the same as is used on the regular output.

Some changes may have to be made in gearing on account of the higher power which the car will develop and also to fit it for the course on which the race will be run. In principle, however, the Grand Prix racer will not differ from the current runabout model. A metallic three-disc clutch will be used, transmission will be of selective sliding gear type, giving four speeds forward and reverse, and final drive will be by side chains. Wheelbase will be 112 1-2 inches. A 36-gallon gasoline tank will be carried in the rear. No decision has yet been made regarding tire equipment for the Grand Prix racer. It is certain, however, that dismountable rims will be employed, the conditions of the race under which every driver has to make all repairs, adjustments, etc., being, in a word, debarred from all outside help—making them essential.

Roberts having returned from the New York-Paris run, work on the car will be pushed ahead rapidly, in order that the racer may be on the course in ample time for the driver to familiarize himself with every turn and grade. No mechanic has yet been selected, the choice, it is declared, resting entirely with Roberts. It is anticipated that the car and its driver will sail for France about the middle of May. Only one racer will be built, but two cars will be sent abroad, the second one to be used in practice work on the course, in order that an unforeseen mishap at the last moment may not ruin the Thomas' chances of competing.

### ACTIVE SUMMER PROMISED FOR DETROITERS.

**DETROIT, MICH.,** March 17.—A touch of the real thing in the way of races, endurance contests, economy tests and other stunts is in store for Detroiters, as a result of the action taken by the Detroit Automobile Dealers' Association. This organization, comprising practically all the local retailers, has outlined an ambitious program for the summer. The opener will be a three-day endurance test, not unlike the A. A. A. tour, but shorter. It will be conducted through Michigan alone, and prizes will be awarded those making perfect scores. Following this, there will be other events throughout the summer, calculated to arouse interest in the automobile and demonstrate its ability.

Officers of the Detroit Automobile Dealers' Association for the present year are: President, Alex. I. McLeod; vice-president, J. P. Schneider; secretary, George E. Lane; treasurer, J. H. Brady; directors, the foregoing officers and Charles Grant.

### INDIANAPOLIS DEALERS FINALLY ORGANIZE.

**INDIANAPOLIS,** March 17.—As has been anticipated for some time, local dealers are to form a permanent organization. It will be known as the Indianapolis Automobile Trade Association, and articles of incorporation will be taken out within the next few days. The step was decided upon at a recent meeting of the committee having the coming automobile show in charge. It was recalled that there was no dealers' organization, and that each dealer might be held personally liable for any accidents that might occur that week.

A committee was at once appointed, consisting of Frank Staley, R. I. Eads and C. S. Hicks, to take the matter up and arrange for articles of incorporation. The association in the future will have charge of race meets, shows and contests, and matters of interest to dealers in general will be passed on. The association is expected to benefit the local trade greatly.

## SOCIETY OF AUTO ENGINEERS MEET AT THE HUB

THOUGH Boston was down as the meeting place of the first quarterly gathering of the Society of Automobile Engineers this year, one of the chief events of the meeting was the run to Lowell, Mass., for the purpose of inspecting the plant of the Heinze Electric Company, and, incidentally, to partake of a lunch given at the Lowell Country Club, this part of the program having been provided by J. O. Heinze, one of the members. The meeting was opened by President Fay at the Walker Building, Massachusetts Institute of Technology, on Tuesday evening, March 10, with the reading of a paper, entitled, "Perfecting Automobile Ignition," by Mr. Heinze, who supplemented a most interesting talk on automobile ignition by the exhibition of an imposing array of delicate testing instruments of his own invention, with the aid of which he explained the methods he had evolved as the result of a great deal of study, of so standardizing the manufacture of induction coils, that perfect reliance could be placed upon each unit in a coil box having exactly the

At the conclusion of this, the members returned to Lowell, and were first taken through the woodworking plant of the Heinze Electric Company, which is situated on the Merrimac river. Every detail of the various processes involved in converting the rough lumber into the highly finished coil boxes was inspected, and then the cars were again taken for the ride to the main plant, where the electrical work is carried on. This is the building shown in the accompanying photograph. It contains a most complete equipment of automatic machine tools for the production of the numerous small brass parts found on vibrating coils, winding, assembling and testing rooms, a battery of mercury air pumps for the manufacture of X-ray tubes, and a laboratory. The various steps in the building of a coil were followed with great interest, but the *pièce de resistance*, so to speak, was the huge induction coil, capable of producing a spark 50 inches in length. It is the largest of its kind ever built, and in action resembles nothing so much as miniature lightning. The

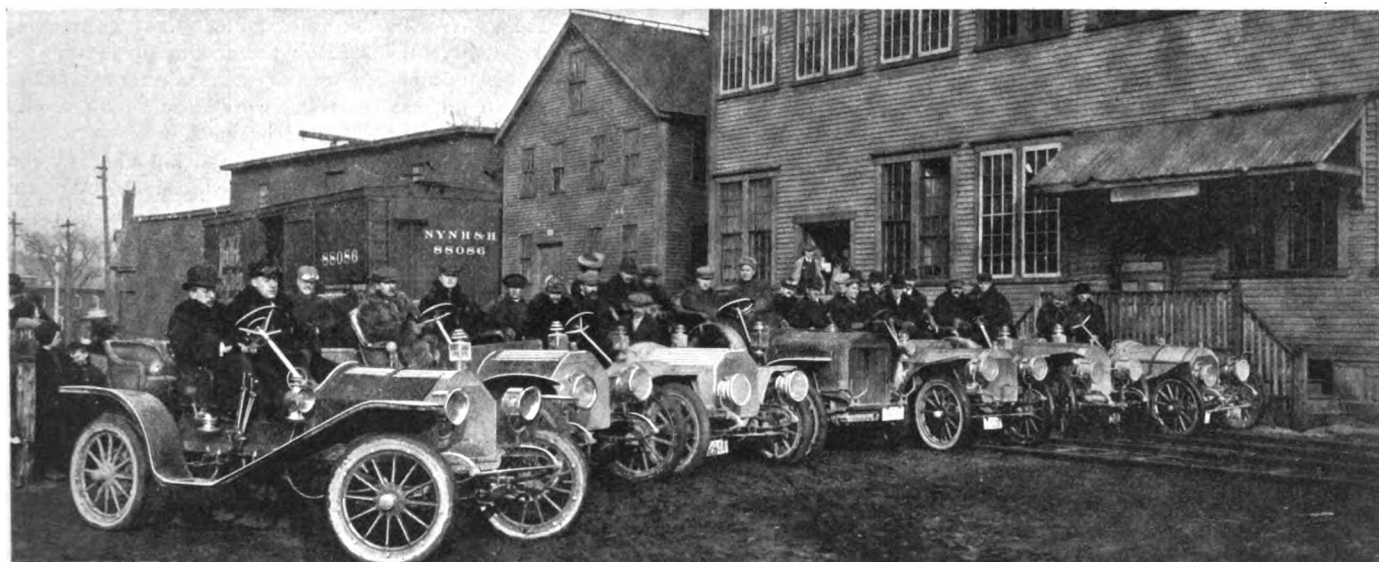

Members of the Society of Automobile Engineers Upon Their Arrival at the Heinze Electric Company's Plant.

same characteristics. The Heinze analogue for illustrating ignition advance, showing exactly the amount of lag taking place between the time of closing the circuit and the occurrence of the spark in the cylinder, was warmly commended by many of the engineers, who had never had an opportunity of seeing this important phase of coil ignition so clearly demonstrated. The reading of the paper was followed by the usual discussion in the course of which numerous points of interest came out.

The following morning, at 9:30, the members gathered at the headquarters of the Bay State Automobile Association, where cars were waiting to convey them to Lowell. The official car of the day was a White steamer, and was followed by a Locomobile, driven by A. L. Riker; next came a Berliet, handled by B. D. Gray, chief engineer of the American Locomotive Auto Company of Providence, and following it came a Stoddard-Dayton. Harold Brown, in his Peerless runabout, was the official guide and pacemaker, but found another aspirant for the same honors in the shape of a namesake driving an Apperson "Jack-rabbit," and as the result of the competition which arose, the thirty odd miles intervening between Boston and Lowell were covered in little less than an hour and a half, despite the unfavorable condition of a considerable part of the road. J. O. Heinze, in a Marion runabout, met the visitors in Lowell, and piloted them out to the Vesper Country Club, about six miles outside the city, where a luncheon was served to the engineers at Mr. Heinze's invitation and which proved to be a most enjoyable affair.

secondary winding is in small sections, separated by built-up plates of mica about 1-8 inch thick, while the primary and secondary windings are separated by a heavy mica tube. It is operated by a circuit breaker of Mr. Heinze's invention.

The return to Boston was made without incident, except where the official car, carrying President Fay and Secretary Hayward, was concerned. A combination of tire trouble and lack of foresight on the part of the driver in taking water, supplemented by ignorance of the route, made its passengers about an hour late for the dinner given to the engineers at the Bay State Automobile Association's clubrooms, in Dartmouth street. Prof. F. R. Hutton, past president of the A. S. M. E., spoke at length concerning a proposed plan of co-operation by the two societies, which was enthusiastically received, and referred to the Council of the S. A. E. for further action. The regular business meeting followed this, at which the election held at the annual meeting was ratified and the proposed constitution formally adopted. The remaining papers, entitled, "On the Design and Construction of Crankshafts," by P. M. Heldt; "A Multiple Unit Road Train as the Solution of the Heavy Goods Transportation Problem," by Joseph A. Anglada, and "Forgings for Automobile Work," by R. W. Funk, were then read, the discussion in the case of the last two being postponed. It was decided to hold the third annual summer meeting at Detroit on June 25, 26 and 27, in connection with the meeting of the American Society of Mechanical Engineers.

## ENTHUSIASM FOR NEW YORK CARNIVAL WEEK INCREASING

PREPARATORY work of a character destined to make the carnival of the New York Automobile Trade Association the finest thing of its kind ever attempted in automobile circles in this country, has been perfected by the committees in charge, and details are practically complete for the opening of carnival week, on April 6. The trade is supporting the event unanimately, and business houses of all kinds and hotels along the line of march, realizing the importance of the carnival from a business standpoint, have given orders for decorations. A big influx of visitors from out of town is expected.

The parade committee is especially desirous of securing as many cars of 1903 and older as possible. The trade can cooperate in this feature by supplying information regarding the present whereabouts of old cars to R. G. Howell, grand marshal, 1657 Broadway, or Col. K. C. Pardee, chairman parade committee, 317 West Fifty-ninth street.

The special trade run and dinner for Friday afternoon, April 10, will have the Hotel Gramatan, Bronxville, as its objective point. Fuller details, with applications, will be sent to the trade later, for reservations at this dinner.

Judging from the general enthusiasm expressed among members of the trade, the parade will undoubtedly be the biggest feature of the carnival, and will prove a big drawing card with the public. Nearly every one that owns a motor car seems to be anxious to have it in the parade, and it is likely that the committee will have to put a limit on the number of cars in each division of the pageant. Blanks will be issued during the coming week to all persons desiring to enter cars in the parade on the evening of April 7.

The course of the parade has already been decided upon. It will start at Broadway and Fifty-sixth street, in the heart of the automobile district, headed by the cars entered in the Briarcliff

trophy race. The various divisions will form in the cross streets west of Broadway as follows:

On Fifty-sixth street—First division, composed of Briarcliff trophy cars, Vanderbilt Cup cars and the historic section of old cars.

On Fifty-fifth street—Second division, composed of dealers' 1908 models.

On Fifty-fourth street—Third division, composed of decorated automobiles.

On Fifty-fourth street—Fourth division, composed of commercial vehicles.

The parade will go south on Broadway to Twenty-fifth street, thence north on Fifth avenue to Fifty-seventh street, to Broadway, north on Broadway to One Hundred and Tenth street and south on Broadway to Columbus Circle, where the paraders will disband. The judges' stand will be on the park strip on Broadway, north of Seventy-third street.

Full swing will be given to the individual fancy in the third, or decorated division, and handsome prizes will be awarded to the cars most beautifully decorated. A special trophy will be offered for the owner who decorates his car most grotesquely. Various firms along Automobile Row are making preparations to decorate the interiors and exteriors of their salesrooms. Many special features of interest are being worked up by the dealers to attract attention to their places of business.

Fort George Hill has been chosen for the hill-climbing contest, which is to be another feature of the carnival. A permit has been obtained from the city authorities for the holding of the climb, either on April 6 or 8. The grade averages more than 11 per cent., and in places reaches 15 per cent. The entry fee will be \$10 for each event. The cars will be sent up one at a time from the starting point at the Dyckman street subway station.

## AMERICAN CARS WELL REPRESENTED AT TORONTO

TORONTO, ONT., March 16.—Preparations are practically complete for the Automobile and Sportsman's Show, which will open at St. Lawrence Arena, this city, March 21, and continue for one week. The show is attracting the attention of American manufacturers, and more of them than ever before

Automobile & Supply Co., Toronto.  
 Dominion Automobile Co., Toronto.  
 Oldsmobile Co., of Canada, Toronto.  
 Canada Cycle & Motor Co., Toronto.  
 Ford Motor Co., Toronto and Walkerville.  
 Hyslop Bros., Ltd., Toronto  
 McLaughlin Motor Car Co., Oshawa.  
 C. N. Pierce & Co., Buffalo.  
 Packard Motor Car Co., Detroit.  
 Maxwell-Briscoe Motor Co., New York.  
 Cadillac Motor Car Co., Detroit.  
 Mitchell Motor Car Co., Racine, Wis.  
 Stevens-Duryea Co., Chicopee Falls, Mass.  
 Dayton Motor Car Co., Dayton, O.  
 Darracq Motor Co., France.  
 Studebaker Bros. Co., of N. Y., New York.  
 Renault Frères, France, England.  
 Napier, S. F. Edge, Ltd., London, England.  
 Ferro Machine & Foundry Co., Cleveland, O.  
 Canadian Fairbanks Co., Toronto.  
 McKeough & Trotter, Chatham.  
 Schofield-Holden Machine Co., Toronto.  
 H. E. Gidley Co., Penetang.  
 N. R. Thompson, Brantford.  
 Beaudry Gasoline Co., Montreal.  
 Walter H. Lowney Co., Montreal.  
 Buffalo Gasoline & Motor Co., Buffalo.  
 Conboy Carriage Co., Toronto.  
 Crofton Storage Battery Co., Toronto.  
 S. F. Bowser Co., Toronto.

will be represented. The railroads have announced a single rate of fare for the round trip to Toronto from all parts of Ontario. Both the Toronto show and the one to be held at Montreal, April 5-12, are being managed by R. M. Jaffray. The following is a list of the automobile and auto accessories exhibitors:

Canadian Rubber Co. of Montreal, Toronto.  
 Diamond Rubber Co., Akron, O.  
 E. Tenham, Brandon, Wis.  
 Dunlop Tire & Rubber Goods Co., Toronto.  
 Nugget Polish Co., Toronto.  
 Gutta-percha Rubber Co., Toronto.  
 Rubber Tire Wheel Co., Montreal.  
 Canadian Puncture Proof Tire Co., Toronto.  
 Geo. A. Haw, New York.  
 E. P. Hopcroft, Toronto, Polson Iron Works.  
 Premier Motor Co., Toronto.  
 Canadian Show Case Co., Toronto.  
 Randall-Falchney Co., Boston.  
 Auto Igniter Co., New York.  
 M. L. Butler, Brighton.  
 Thrall-Fishbeck Co., Detroit.  
 Roberts Motor Co., Clyde, O.  
 Ferro Machine & Foundry Co., Cleveland.  
 International Carriage Co., Brighton.  
 Motz Tire Co., New York.  
 Reo Motor Car Co., Lansing, Mich.  
 Motz Clincher Co., New York.  
 Jno. J. Robinson, Toronto.  
 Comet Motor Car Co., Montreal.  
 Winton Motor Carriage Co., Cleveland.  
 Kissel Motor Car Co., Hartford, Wis.  
 Premier Motor Mfg. Co., Indianapolis.  
 Royal Motor Car Co., Cleveland.  
 St. Lawrence Engine Co., Brockville.  
 Canadian General Electric Co., Toronto.

# DESIGN AND CONSTRUCTION OF CRANKSHAFTS\*

By P. M. HELDT. MEMBER SOCIETY OF AUTOMOBILE ENGINEERS

THE crankshaft of the motor of a modern car is at once one of the most expensive single pieces that enter into the whole construction, and a part that requires the greatest skill of the machinist's art for its proper execution. The crankshaft is an old mechanism, having been in use for over a century, on steam-engines, but the problem of the multiple crankshaft, for high-speed internal combustion engines, is a relatively new one. The abolition of the crankshaft in engines is a hobby with numerous inventors, and during the ten years of the writer's connection with the automobile industry, numerous crankless engines have been brought to his attention. I am inclined to think, however, that a principle of construction which has withstood the test of time for over a century must have unusual merits.

In the design of a crankshaft the first requisite is that it must be strong enough to resist or withstand the stresses to which it is subjected in operation. These stresses are of a very variable and complex nature and almost impossible to determine from theoretical considerations alone. Of course, it is only necessary to consider the maximum stresses for any given portion of the shaft. On the crankpin there is evidently a bending stress which is at a maximum at the moment the explosion occurs. The crank arms are subjected to compound stresses, viz., a bending stress in the plane of the crank and a bending stress in a plane at right angles to the crank. To better understand the first of these



Fig. 1.—Illustrating effect of stresses on crank members.

stresses we may consider the crank stationary in the top dead center position; when the explosion occurs, the pin and crank arms will flex, somewhat similarly as when a load is applied to a beam fixedly supported at its two ends. The flexure in actual work is, of course, infinitesimal, but we may obtain an idea of the general shape the parts assume by considering a shaft of very small cross-sections and long members. When such a crank is subjected to a load corresponding in direction to the pressure of explosion, the crank members will assume approximately the form shown in Fig. 1. I have here assumed that the two shaft journals are held rigidly, while the crankpin is capable of bending. This assumption has some justification because the crankpin bearing is often much shorter than the main bearing. This illustration gives a good idea of the localization of stresses at the joint between the crank arms and the main journals. It is at this point that practically all breaks of crankshafts occur. To minimize the danger of breakage liberal fillets should be provided.

The crank arms act as lever arms for turning the shaft and as such are subjected to bending stresses which increase from the joint with the crankpin to the joint with the main journal. The latter is subjected mainly to torsional stresses.

The crankshaft must be designed to withstand these stresses, and yet must be no larger than necessary, because this would mean not only an amount of dead weight would have to be carried, but that—if the journals were of more than the necessary diameter—the friction loss would be greater than need be. In spite of the fact that there are thus two distinct reasons for keeping down the size of the crankshaft, I do not believe that too much peeling here is advisable. It has been said—and I believe is the general opinion among engineers—that every crankshaft breaks in the course of time, its lease of life depending upon the character of its material and the maximum stress regularly sustained at any point. Experiments with so-called

endurance machines have shown that the number of repetitions of stress which a part will withstand is directly dependent upon the value of the stress as compared with the breaking strength of the material; in other words, upon the factor of safety. Now, the aim in crankshaft construction should be to make the maximum unit stress so low that the endurance of the crank equals the normal lease of life of the motor. Breakage of a crankshaft while the motor is still in good working condition will always

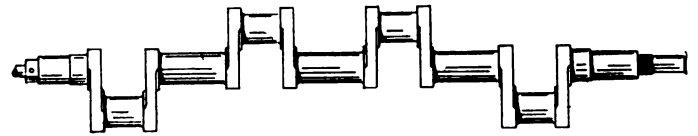

Fig. 2.—Five-bearing type of crankshaft.

be regarded by the owner as proof of improper design or poor material, while there is, of course, no advantage in endurance much beyond the normal lease of life of the motor. But this endurance is not subject to exact calculation and it is far better to err on the side of safety in proportioning the crankshaft. This policy of making the shaft considerably heavier than would seem necessary is followed by the German Daimler Company.

In the production of crankshafts a number of entirely different processes are followed. In some of the old style marine and small stationary motors are found crankshafts which are produced from a piece of machinery steel which has a kink put into it by a steam hammer to serve as the crank, and then has the pin and main journals turned up in the lathe. The manufacturers of these motors claim the advantage that in these shafts the grain runs lengthwise of the shaft. This latter point cannot be advanced in favor of the crankshafts used in the majority of modern high-grade, four-cylinder motors. These shafts are made from solid prismatic slabs of metal of the same dimensions as the over-all dimensions of the completed shaft. "Whittling" a shaft out of such a block of metal entails an enormous amount of machine work and comes very expensive, but is thought to be justified by the very superior metal thus obtained in the finished shaft. The "grain" argument in favor of crankshafts forged to shape, as against those turned from solid slabs, has

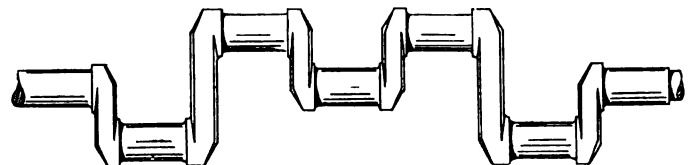

Fig. 3.—Crankshaft with two throws between bearings.

probably very little weight, because metallurgists are now generally leaning toward the opinion that steel is not fibrous at all, but is naturally of a crystalline structure and as strong in one direction as in another. Many crankshafts of modern engines are made from drop forgings and hydraulic forgings, and the advantages of this method of construction are that it greatly reduces the amount of machine work that must be done upon the shaft. In the case of crankshafts for low-priced cars it is the custom to leave the crank arms of drop forged crankshafts in the rough and only to finish the journals. It is really hard to see what advantage there is in finishing the crank arms, except that a crank so finished looks better, but as the crank of an automobile engine can only be seen when the motor is taken apart for repairs, this feature seems to benefit only the repair man. Of course, it is hardly necessary to add that a crankshaft made from a slab must have its arms machine finished.

The materials most largely used for automobile crankshafts

\*Paper read before the Society of Automobile Engineers at Boston.



are carbon steel of from 35 to 50 points carbon, nickel steel, nickel chrome steel and vanadium steel. Formerly it was the custom in France, I understand, to case harden the crankshaft journals and grind them. This treatment undoubtedly improves the bearing properties of the steel. The case hardening process has now been given up and instead the shaft is subjected to a heat treatment. In some cases this treatment consists in raising the shaft to a temperature of about 900 degrees Centigrade, quenching it in oil and then reheating it slowly to 500 degrees Centigrade. This treatment is given the shaft after it has been roughed out, for the reason that it hardens the metal and renders the removal of more material difficult.

The treatment given the best results depends, of course, entirely on the particular grade of steel used, and the subject of the different available steels is so vast that it can be only referred to in passing. Whatever grade of steel is used, however, it is essential that it be derived from very pure ingredients and that the sulphur and phosphorus components be as low as possible.

Perhaps the most interesting phase of crankshaft design to the automobile engineer is that of the proportioning of the parts, from the pressures and stresses developed in the engine on the

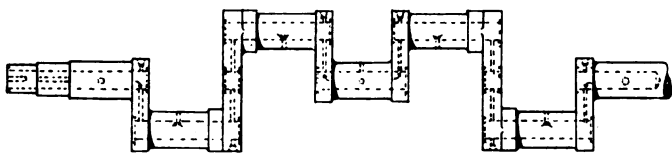

Fig. 4.—Three-bearing crankshaft drilled for lubrication.

one hand, and the strength of the material (generally recommended by a metallurgical engineer) on the other.

For the purpose of this discussion we may divide the different single-piece shafts used in automobile engines into four groups, with one, two, three and four throws between main bearings respectively. The first two of these groups are by far the most common; that type with three throws between main bearings has been used on some small experimental triple-cylinder engines, while the last type with four throws between main bearings is now coming into use for taxicab or "block" engines.

It is at once apparent that in a crankshaft with a main bearing between each pair of throws or at both sides of the crank there is little chance for heavy bending stresses to occur, provided the bearings are rigidly supported by the crank chamber or base. In a crankshaft with a double throw between main bearings, the bending moment is already a much more important factor, because of the greater relative distance between supports. In a crankshaft with four throws between the main bearings the bending moments become a factor of extreme importance.

In a crankshaft of the first type the length of the crankpin and main bearings is limited, and for a certain size of cylinder bore and an average compression figure the crankpin must be of a certain diameter if the specific pressure on the bearing surface is not to exceed the maximum permissible value. If both the diameter and the effective length of the pin are made directly proportional to the cylinder bore, the projected area of the pin bearing will be proportional to the piston area and consequently to the maximum pressure that it will have to support. Some years ago I gathered data of the crankshafts of a large number of American, single-cylinder crankshafts, practically all of ordinary carbon steel and made by the drop forging process. I found that the average proportions were:

$$\text{Pin diameter} = .3 \times \text{bore.}$$

$$\text{Pin length} = .42 \times \text{bore.}$$

$$\text{Width of crank arm} = 1.4 \times \text{pin diameter.}$$

$$\text{Thickness of crank arm} = .5 \times \text{pin diameter.}$$

The material used in these shafts had perhaps an average tensile strength of 65,000-70,000 pounds. If alloy steels of 105,000 to 125,000 pounds tensile strength were substituted the proportions could be materially changed. The crankpin could be made

somewhat longer and of smaller diameter, and the arms could be reduced in size in both directions of their cross-sections.

A close calculation of crankshaft dimensions should, of course, take into account both the maximum pressure developed in the cylinder and the tensile strength or elastic limit of the material. It is evident that in a crank with double throws between bearings the crankpins must be larger in diameter than in a crank with only a single throw between the bearings, of the same material and for the same size of cylinder. The long crank arm in the former case also must be considerably heavier than the short crank arms. From comparatively recent data of a considerable number of four-cylinder crankshafts with double throws between main bearings, I have reached the conclusion that in average practice the pin diameter in such cranks is

$$d = .4 \sqrt[4]{\frac{P^2}{S}}$$

where  $P$  is the maximum pressure on the piston and  $S$  the tensile strength of the crankshaft material. For a crankshaft with only a single throw between main bearings the formula becomes

$$d = .38 \sqrt[4]{\frac{P^2}{S}}$$

The coefficients .4 and .38 may seem to close together that the difference is not worth talking about, but it must be remembered that the strength of a crankpin is proportional to the cube of its diameter, and the former formula gives a pin about 17 per cent. stronger than the latter. The length of the crankpin can be found from the permissible unit bearing pressure and the bearing diameter thus determined. In a crank with two throws between main bearings there is no reason why the bearings should not be made comparatively long, as there is plenty of room, and the unit bearing pressure may be limited to 1,200 pounds per square inch. In the other type of crank the space is limited and the unit pressure on the crankpin bearing surface must be carried somewhat higher, 1,500 pounds per square inch being an average figure.

The proper diameter of the main journals is, of course, the same for all types of crankshafts. The resistance to torsion of the main journal must be proportional to the maximum pressure on the piston and to the length of the stroke. I have found the

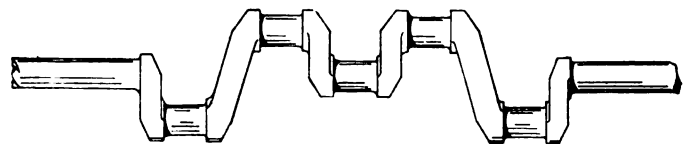

Fig. 5.—A variation of the three-bearing type of crankshaft.

following formula to express very closely the average practice in dimensioning the main journals:

$$d = 2.6 \sqrt[3]{\frac{sP}{S}}$$

In proportioning the crank arms it is usual to make the width somewhat greater than the crankpin and main journal diameters in order that it may provide a shoulder for the bearings, the average width being  $w = 4/3 \times$  crank-journal diameter. When this width is used the average thickness of short crank arms is given by the formula

$$t = \frac{d^3}{w^2}$$

and that for long crank arms by the formula

$$t = .72 \sqrt[2]{\frac{d^3}{w}}$$

This practice of making the crank arms equal in width to the crankshaft diameter plus about twice the height of the flanges on the ends of the journal sleeves is a heritage from the period

of single-cylinder engines. There can be little doubt that in a crankshaft with two or more throws between main bearings advantages in the way of lightness and strength could be secured by making at least the long arms narrower and of somewhat greater thickness. This idea has been carried out in some crankshafts made of drop forgings and in which the arms remain unfinished. In these shafts the crank arms are forked with seg-

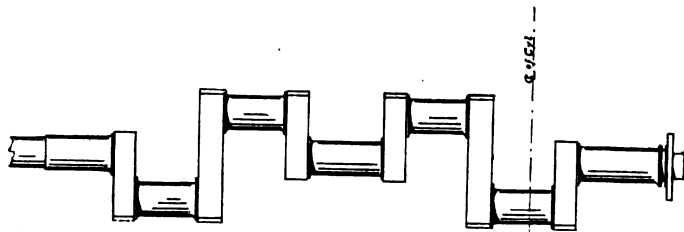

Fig. 6.—Three-bearing crankshaft longitudinally offset.

mental prominences on opposite sides of each journal, so as to form a complete circular shoulder the height of the journal sleeve flange. In shafts finished all over it is, of course, impossible to provide these prominences, but it does not seem at all necessary that there should be a continuous circular shoulder at the end of each journal, as, unless no provision is made to take the end thrust of the clutch up within the clutch itself, there is little end pressure on the bearings of a crankshaft.

Certainly the most striking and daring innovation in crankshaft design is the four-cylinder crankshaft with only two main bearings, as used on a number of "block" motors fitted on taxicabs. When one considers that in a single-cylinder engine the average distance between main bearings is only about seven-eighths of the cylinder bore, while in a four-cylinder "block" engine with only two main crank bearings it is at least four times the cylinder bore, it can easily be realized that the bending moment on the shaft at the moment of explosion is relatively great. Of course, it is possible to make the shaft so heavy that the unit stress will be quite reasonable, but it is desirable to keep the dimensions down, not only because of the saving in weight thus effected, but also because there is less friction loss.

It is hardly likely that a shaft of this type will be made of carbon steel, with its relatively low elastic limit; nickel steel and chrome nickel steel are undoubtedly essential to stand the strains imposed on a crankshaft of this type for a period of time approaching the life of the engine. It is also obvious that with a crankshaft of this kind considerable bending will occur at the moment of explosion, and care must be taken in the design to insure that there can be no localization of strains from this bending. With only two bearings, if plain or parallel bearings were used, they would necessarily have to be of more than the usual length, and the two ends of the shaft would be almost rigidly held, so far as bending is concerned. This would concentrate the strains at the inner ends of the main journals, and the shafts would undoubtedly break at these points in short order. Some form of bearing which permits of some disalignment of the journal portion of the shaft appears to be absolutely necessary. The annular type of ball-bearing fulfills this requirement and seems to be exclusively used for the purpose at present. Some sort of parallel bearing with a spherical seat, as often used on dynamos, might possibly also be made to serve the purpose, but would hardly be as good as the ball-bearing. Localization of strains at the ends of the crankshaft journals is also a serious matter in crankshafts with less than four throws between supports, and probably a majority of all crankshaft breaks occur at these points. That this danger must be guarded against by providing fillets of large radius at the junction of journal and crank arm can be read in almost every article on crankshafts, but is one of those important rules of design that will bear repetition.

One of the illustrations herewith shows the crankshaft of the Delahaye 12/16-horsepower block motor, which is probably typical of this design of crankshaft. In studying the layout of this shaft

it will be observed that it is not in perfect mechanical balance, there being nothing below the center line of the shaft in the drawing to balance the two short crank arms extending upward. It would, of course, be an easy matter to secure counterweights to these outer crank arms, but in the writer's opinion a more advantageous plan would be to increase the cross-section toward the middle of the shaft. The two long crank arms would then be slightly tapered from one end toward the other, and the two middle crankpins would be of larger diameter than the two outer ones. This latter feature, necessitating two different designs of connecting rod bearings, and possibly of connecting rods, would be the reverse of an advantage, but otherwise the construction would have at least two advantages. The bending moment in a structure like this increases from the ends towards the middle, and in order to reduce the unit stress to a minimum, with a given weight of metal, the section must increase from the ends towards the middle. Further, if the two inner crankpins are heavier than the two outer ones and the long crank arms taper from the inner to the outer ones, the shaft might be made to balance perfectly without extra balance-weights.

In connection with the question of balancing four-cylinder crankshafts, the point is sometimes made that if cranks extending in opposite directions from the shaft and located at some distance from one another in the lengthwise direction of the shaft are depended upon to balance or neutralize one another's centrifugal and inertia effects, this can only be accomplished at the expense of internal strains in the shaft, and it is contended that the only proper way to balance a four-cylinder shaft is to provide each short crank arm with a counterweight extending in the opposite direction. This idea is carried out in at least one French engine. The writer believes it to be an illusory refinement, as the increase in weight is a much greater detriment than the strain on the shaft due to the balancing effect of side-wardly displaced opposite cranks.

If the four-cylinder, two-bearing crankshaft should prove a permanent success it would mean an important simplification in engine construction. Doing away with the standards for intermediate bearings, and with these bearings themselves, it would lead to a considerable saving in the weight of the crankcase. The weight of the crankshaft itself would probably be not very much more than that of an equivalent crankshaft of one of the two usual types, because the greater necessary cross-section of the shaft parts would be partly compensated for by the simpler form (fewer members). The saving in the work of

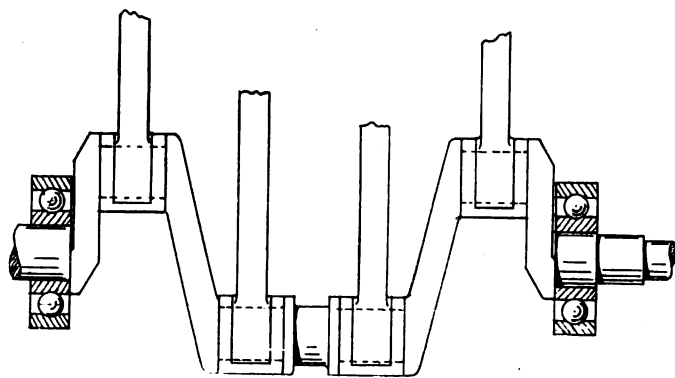

Fig. 7.—The most recent development in crankshaft design.

machining the crankshaft and fitting the bearings would be an important item. It is the writer's belief that for the best distribution of metal in a shaft of this kind the section of the two long arms should be nearly square. As to the ultimate success of this form of crankshaft, only continued experience can tell, and it would be a waste of time to seek to argue this question, as it is probably not so much a question of strength as of weight.

The accompanying cuts illustrate crankshafts of 1907 and 1908 models of American four-cylinder engines, which show a considerable variety in design.

# APPARATUS FOR THE STUDY OF AUTO SUSPENSION\*

IN repose, the reactions of an automobile on the passenger are the equal and directly opposed result of his weight  $P$ . Generally speaking, they are not quite the same while the car is in motion. As the result of the oscillations due to the irregularities of the road, the center of gravity of the passenger describes a curve, more or less erratic, about a line parallel with the surface of the ground traveled over. Let it be assumed, for greater simplicity, that the chassis remains parallel to itself during its movement, designating  $\gamma$  as the value of its acceleration. The resultant of the reactions of the car on the passenger then no

longer constitute a vertical force equal to  $P$  and constant, but a variable vertical force as  $\gamma$ , of which the value is:

$$P\left(1 \pm \frac{\gamma}{g}\right), \quad g = 9.8088$$

the  $\mp$  sign corresponding to ascending movements of the chassis, and the  $-$  sign to descending movements. It will be apparent that these are the cause of the fatigue of the passenger.

Instead of being able to permit his muscles to remain

in repose in a state of tension corresponding to the action of the force  $P$ , which is their normal state, he must accommodate them to the state of tension corresponding to the action of the constantly variable force:

$$P\left(1 \pm \frac{\gamma}{g}\right).$$

It will be apparent that the fatigue resulting from this continuous strain is proportionately greater, as the amplitude of the variations of that force, and in consequence the maximum value of  $\gamma$ , is greater. What is true of the fatigue of the passenger, applies with equal force, taking the mechanical signification of the word, to every stress of the chassis and the carriage work. A low maximum value of  $\gamma$  is therefore an essential element of comfortable riding and of durability in the car and each one of its parts.

In the accompanying illustration, Fig. 1, let it be assumed that the body of the mass  $M$ , attached at a point on the chassis by means of a vertical fastening, of which the tension in repose is represented by  $F$ . Then when the acceleration of the vehicle is equal to the tension  $F$  becomes  $F \pm M$ , in such a manner that the measure of  $\gamma$  is reduced to the measure of the variation of the tension  $F$ . The following is a description of the manner in which M. Boyer-Guillon, head of one of the departments of the laboratory of the Automobile Club of France, and myself, have applied this principle to the construction of an apparatus for the experimental study of automobile suspensions. The body of the mass  $M$  is a cylindrical weight which may be caused to oscillate about an axis  $AA$ , perpendicular to a second axis as shown. The apparatus is arranged in such a manner that the center of gravity of the weight  $M$  falls upon this second axis, as shown in the plan view, Fig. 2, and in the horizontal plane of the axis  $AA$ , as shown.

The weight  $M$  is drilled to form a cylindrical cavity in which may be mounted the indicating spring  $R$ . The other end of this spring carries the stem  $VV$ , which runs through the weight  $M$ , and is guided by the frame which carries the entire apparatus and by the transverse piece  $T$ . This stem runs through the weight  $M$  without coming in contact with it at any point, and its upper end is provided with a milled screw which tightens up against  $T$ . The weight  $M$  is pressed upward by the action of the spring and rests against the washer  $C$ , fixed to the transverse piece  $T$ . In using the instrument, turning the milled screw down draws the stem  $VV$  upward, and, as a result, compresses the spring, thus applying the weight  $M$  against its stop with more and more force. The screw  $P$  carries a drum on which is marked a scale, permitting of the accurate measurement of the compression of the spring  $R$ , as the screw is turned up or down, and in consequence affords a means of ascertaining the pressure of the weight  $M$  against  $C$ , which is the difference of the tension of the spring  $R$ , and the weight  $M$ . The pressure  $p$  may be likened to the tension of the fastening of the weight to the chassis, which, as already mentioned, has been given as  $F$ .

With the aid of an electric current, it is possible to observe with considerable precision by means of the interruption and reestablishment of the contact, the moment that  $M$  is separated from its stop. At that instant, the variation of the tension is precisely  $p$ , and as a consequence, the value of the acceleration of the chassis may be determined. The apparatus is employed in the following manner. It is attached to a point on a car placed upon the drums of a testing machine, or run over a surface upon which have been arranged obstacles of a predetermined height and profile. The screw  $P$  is regulated to a nicety to the point where the weight  $M$  separates from its stop upon passing over these obstacles. The tension of the spring is then taken. By this means, it is possible to determine the maximum value of the acceleration of the chassis on passing over a known obstacle, and the characteristic value of the method of suspension of the car.

## AUTOMATIC CARBURETERS AND FUEL TESTS.

When fashion decides that the carbureter of every automobile, regardless of type, shall be equipped with a carbureter without hand adjusting gear on it and that shall provide a constant and uniform, homogeneous mixture, whatever may be the speed of the motor, as it is put in the catalogues, the innovation will certainly be favorably received, because it will mark the end of an annoying subjection to this part, says Pol Ravigneaux in *La Technique Automobile*. So-called automatic carbureters flourish, but they are a debauch of diaphragms, slides and valves, designed to make up for the deficiency in skill of the hands of their users. In fact, the greater parts of the present carbureters, simple or complicated, crude or otherwise, give sufficiently good results, but somewhat to the detriment of economy. It is necessary that they automatically take care of the speed of the motor and in this they acquit themselves well, but this is not sufficient. They should do this with the best possible results in economy, and things are far from this stage at present.

Now that economy tests are the order of the day the almost unanimous return to the non-automatic carbureter may be remarked, or at least the addition of a supplementary air slide. The latter is susceptible in the hands of a good driver of giving excellent results. It may be asked if this addition is not a step toward an evolution contrary to the present trend of progress, for it cannot be denied that the automatic carbureter, on the score of simplicity, is not a great step forward. As the result of such economy tests as that afforded by international races of which the Grand Prix of the A. C. F. is an instance, there should be great progress made.

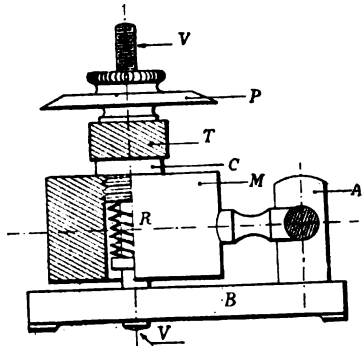

Fig. 1.—Part sectional elevation of device.

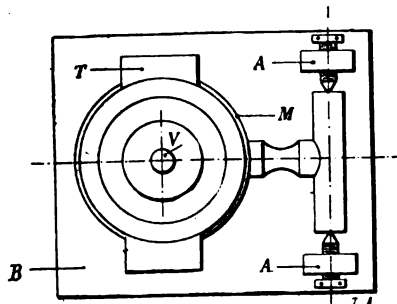

Fig. 2.—Plan view of the apparatus.

\*Translation from "La Technique Automobile," by C. B. Hayward.

# MOTOR TROUBLES AND HOW TO OVERCOME THEM

By ARTHUR H. DENISON.

THERE is no doubt that the modern gas engine is capable of making a great deal of trouble for its operators. It is also a well-known fact that trouble of the simplest form is usually the hardest to locate, unless certain precautions are taken. A general rule, covering the majority of forms of trouble found in the everyday use of the car, may be expressed thus: "The simpler matters seem, the worse they are," and vice versa.

A motor will never give trouble while running without also giving very plain indications of what is ailing it. As an illustration: If a person steps to a lighted gas jet and slowly shuts off the supply of gas, he may observe the effect on the flame, noticing it slowly shrink in size as the pressure of gas is reduced and when the supply is shut off the flame will die away. It follows, therefore, that if the same person was sitting in a room lighted by a single gas jet, and the light began to grow dim, he would look at the source of light. If the flame had shrunk, similar to that in his experiment, he would come to the conclusion, without need for further reasoning, that the supply of gas had failed.

Thus it is with our motor, with the difference that the phenomena present must be interpreted by the ear instead of the eye. The modern owner, looking after and making a close study of his car, will do well to consider just how the car or motor acted previous to "giving up," and not jumping instantly to the conclusion that the carbureter is in need of adjustment, or that the man that built the motor didn't know his business. Motor troubles are simply the motor's methods of protesting against working under unfavorable conditions. When trouble of any kind has been located and repaired, either on the road or by the garage repairman, the operator or owner should have the trouble traced backward to the cause and forward to the effect, satisfying himself of the relations between cause and effect, or how the cause could produce such an effect. In the majority of cases, many things not directly connected with the cause must be considered.

To illustrate this, let us consider a motor that is back-firing through the carbureter. This trouble, when not understood, is usually very alarming to those witnessing it. This would seem to indicate at once carbureter trouble, but a knowledge of the car is again essential. Our first step is to determine what condition of the cylinder and its inside arrangements will allow sufficient gas at a temperature high enough to ignite the incoming gas on the suction stroke, remaining after the exhaust stroke has been completed and the exhaust valve closed. There is only one reason which can cause this to take place, and that is the slow burning of the gas during the previous power stroke, consequently combustion is not nearly complete when the exhaust valve opens. The result seems to be that the exhaust stroke does not completely clear the cylinder, partly due to back pressure from gas expanding in the exhaust manifold. The vapor remaining is in the course of combustion, and when the inlet valve opens, allowing fresh gas to enter, the temperature is still sufficiently high to ignite the fresh gas, the wave of flame passing through the open valve manifold and finally blowing out through the air inlet. There is no danger of the gasoline in the standpipes catching fire, as the flame passes them at a speed possibly much higher than 1-100 of a second per foot. If fire did happen, the suction stroke following close would extinguish the slight flame.

### Locate the Cause and Then Seek the Reason.

With conditions found, we must next find reasons. The spark plugs will be very sooty. If the car is equipped with

jump spark battery ignition, the possibilities are that the vibrators are badly in need of attention or the batteries exhausted. If the car be fitted with low tension magneto ignition, the location of the trouble is almost sure to be in the carbureter, and an examination of that organ should reveal trouble with the auxiliary air inlet, or some dirt in the spray nozzles, preventing a free flow of gasoline. A dirty carbureter, or opening the throttle quickly on any motor, is liable to cause backfiring. The remedy in either cause is obvious—adjust the tremblers, recharge or renew the batteries, or clean the carbureter. If the carbureter is of the adjustable needle valve type, the manufacturer should, after testing and setting it, provide a method of quickly determining whether the adjustment is near the correct point—as determined in the original tests. If the manufacturers have neglected this, the owner or operator should mark it himself.

In one of our experiments the action of the motor gave us a good indication of where our trouble was. Some one

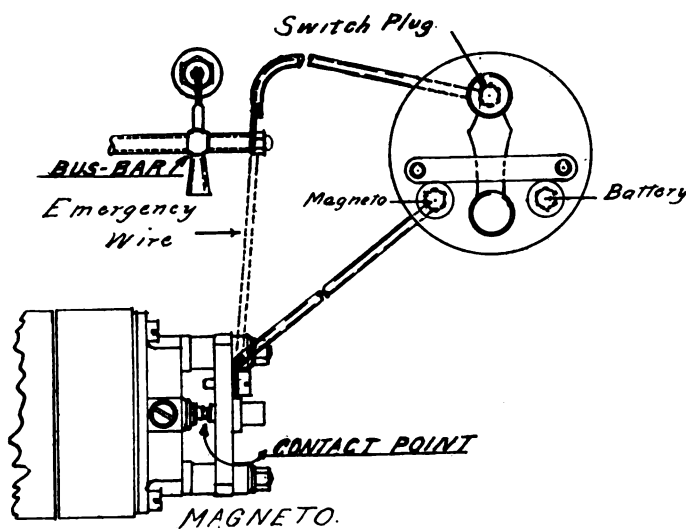

Diagram Showing Experiment to Locate Ignition Trouble.

may ask: "Well, supposing a motor, running smoothly, suddenly stops firing; have you any indication of its trouble in that case?" The answer is simple. If we break the electrical connection by turning the switch, how does the motor act? Therefore, hunt for a broken wire or permanent short-circuit of the primary wiring connections. Cause and effect are traced very easily there. On the other hand, troubles may come and disappear of their own accord, and others may come and we overcome them without having any more knowledge at the end than at the beginning. It is only by intelligently attacking each difficulty and making ourselves as familiar as possible with the conditions under which our motors work, and refuse to work, that we can expect reasonable satisfaction from this performance. In the following accounts the troubles belong to the list that cannot be traced, and the motor's performance did not aid us any.

### Typical Instances of Mysterious but Simple Causes.

While road testing the Excelsior cars last year, I brought a car back to the factory one day, the motor running very well. I stopped the motor, letting it stand for about half an hour, and when I tried to start it up again it would not give a sign of an explosion. It was equipped with low-tension ignition and magneto. Thinking that there might be a short-circuited plug, I tried cutting out each cylinder successively, then two at a time, but this did not help me. The



timing of the magneto was next examined and found correct, and in order to eliminate trouble in the wiring or switch, I ran a wire directly from the magneto to the bus-bar (see sketch.) This didn't aid matters. Then I sent for a testing magneto to ring out both connections and magneto. One test seemed to indicate a short-circuit in the magneto and the next nothing wrong. Next, I got a set of dry cells and coil, connected them on to the other side of the switch and the motor started readily, when cranked, but refused to run on the magneto. Finally, one of the other testers, who had been assisting, had taken out the carbon brush that was pressing against a collecting ring which has attached to it the ground end of the armature winding completing the ignition circuit. The carbon was found very dirty and foul. It was cleaned out, and a little gasoline squirted in to clean the brush holder, replaced, the motor cranked and it started readily. The cause of the trouble here is rather obscure, but it is probable that a little speck of dirt held the brush off contact. Other influences, such as the fact that the current from the magneto will overcome a certain amount of resistance, etc., were valueless; that motor wouldn't start.

Later, one of the other testers was bothered with trouble rather similar to the above that defied, for nearly an hour, all his efforts to locate it. The car, of the same make, was fully equipped and party were touring when the engine died in a narrow road in such a place that both the road and a suburban trolley line were tied up. He made all the tests possible to make on the road, as described above, including a close examination of the switch and connections, without any result, and, as a last resource, connected the magneto directly to the bus-bar (see sketch). On cranking the motor it started readily and a new switch overcame the trouble. The old one, when tested later, seemed to be in good condition. I was not informed whether the motor was rewired or not, but the hood support passed directly over the connections through the dash, and there must have been a leak there. Otherwise broken insulation must have provided a path for the escape of the current at some other point.

Another peculiar trouble that I cannot explain occurred to me while about half way on a long trip—about a hundred miles from start and from finish. Cylinder No. 1—front—start-

ed to miss irregularly while traveling up a very slight grade. It rapidly became worse, and I tried rocking the spark lever sharply up and down its quadrant. Retarding the spark finally seemed to help it a little—for a distance measured most conveniently in feet. With make-and-break ignition, the armature of the magneto was set 1-32 inch past center with igniters fully advanced. The motor seeming to improve by retarding the spark appeared to indicate a leaky plug, so I stopped and changed it, putting in a new one and resetting the hammer at the same time. The motor ran good for about one hundred yards when the performance began again, exactly similar to the first symptoms of trouble. I stopped again, took out the plug, and examined it, replaced it, and examined carefully the exterior mechanism of the igniter to see if there was any possibility of its sticking or binding anywhere.

#### Sit Down and Reason Things Out Leisurly.

Everything seemed right, and on starting the motor it ran good for a hundred yards or so again, then started to miss. I stopped and then took out the complete igniter—both hammer and plug or anvil. Both still looked very good, the hammer working freely in its bushing and the head showing so little the pitting action of the spark that I didn't consider it possible to have trouble there. While considering matters, I picked up a file and dressed the head a little, and having done all I could think of, put things back carefully and started the motor. The next time I had occasion to touch the igniter was after 1,500 miles had been traveled. What action or combination of factors cured that trouble I cannot say, for the reason that I have seen hammers and plugs both pitted 1-8 inch deep, firing well.

These three accounts may help bear out my statement that the simpler matters seem, the worse they are. As in the first instance, a dead motor is liable to make things more difficult than if the motor was running until stopped by or gave other indications of trouble. Should you who read them be stopped on the road this Spring with trouble that eludes you, sit down on anything convenient and spend five minutes in thoughtful consideration. It may save you an hour's work, and it will certainly save your temper and patience more than aimless fussing.

### AS H. H. FRANKLIN SIZES UP OUTLOOK.

By H. H. FRANKLIN.

"A luxury and the first to suffer," was said of the automobile when the panic came. It made the thoughtful maker of automobiles "sit up and take notice," and those who were able to appreciate the significance of business conditions then are the ones who are now reaping, and will reap, the benefit of their foresight.

The panic through which we have been passing has tended to reduce extravagance and useless expenditure. Owners of automobiles have studied the situation; new buyers are investigating, and some, indeed, refuse to buy at all. The wealthy man who was going to put a large price into a large machine is looking for something costing less, and likewise the man with less money is more cautious, but sales are being made, and more sales will be made.

The question is, "What will be in demand?" When the financial stringency began, it appeared to me that automobiles of medium price and medium size would suffer the least, and that as the Franklins were in that class and also light in weight, and very economical, our company would continue to do a large business. What happened? Our sales in November were \$38,142 more than in November, 1906. Sales for December were \$46,373 more than in December, 1906. While January sales showed no increase, they equaled December sales, and in February the shipping orders are coming in at an average daily rate of 35 per cent. over the daily rate of January.

### ERRORS IN REASSEMBLING NOT UNCOMMON.

It is not an altogether unknown thing for the best paid mechanics and foremen to get things together wrong when reassembling a car, so it naturally follows that the amateur may readily commit similar sins. In one case the omission of a small part of the carbureter permitted the latter to function after a manner and many blind trails were followed before the true cause of the trouble was discovered. This applies particularly to the auxiliary air inlet valve. The latter is rather a ticklish piece of mechanism and one to which the maxim about letting well enough alone applies with all its force, so that it may readily be imagined that failure to assemble correctly would not be apt to improve matters to any great extent.

Sometimes the manufacturer is guilty of an error in the original assembling, but with the painstaking methods of testing cars that have come into vogue, the occasions on which such mistakes can escape the fine-tooth comb process of inspection and trial to which every part of the car is put must be rare indeed. It is the repairman who is most often at fault, and as the majority of cars, though seemingly very much alike, differ more or less in detail, the assembler is often prone to put things back on the car according to preconceived notions of his own as to the way they should go rather than according to the manner originally intended for them by the designer of the car. Of course, this does not apply to the carbureter alone, but to practically every part of the car with which the repairman has to do.

## LETTERS INTERESTING AND INSTRUCTIVE

### PUTTING IN A NEW PROPELLER SHAFT.

Editor THE AUTOMOBILE:

[1,232.]—Will you please tell me how I can do away with the rear universal joint on a shaft-driven steam car—no change speed or clutch? The shaft between the rear universal and rear axle is about 9 inches long, running in a brass bearing. This bearing soon wears, allowing the shaft to jump, especially when running slow or turning. If possible, I would like to put in a solid shaft with the one universal and slip joint at the engine. C. H. HOYT.

Jefferson, Ore.

Without further details than you supply in your letter it is rather difficult to advise you definitely on this point. We should think, however, that unless the arrangement at the rear axle you speak of is altered you will have this trouble regardless of the situation of the single universal. As at present arranged this bearing receives all the angular thrust of the universal, which accounts for its rapid wear. Why not place the rear universal as close as possible to the bevel driving pinion, thus doing away with the 9-inch shaft you speak of? That is, instead of the 9-inch shaft and its brass bearing, substitute an annular ball-bearing of the thrust type and place the universal directly forward of this. Or, as suggested, the universal and slip-joint might be placed directly back of the engine. If the shaft between the engine and the rear axle is very long, we should not advise the use of a single universal at the forward end, but would prefer two.

### ABOUT RENEWING OLD DRY CELLS.

Editor THE AUTOMOBILE:

[1,233.]—In the January 23 issue of "The Automobile" L. M. Lowe, M.D., writes regarding the renewing of "Dry Batteries." We have a preparation which we use to renew old dry batteries, and it works O. K. We have made the following test: We have an electric engine which requires three new dry batteries to turn it over and four to run it at a moderate speed. We took six batteries, which before being treated with our solution were perfectly dead, and they ran the engine at about the same speed as the four new ones. The cost of renewing old cells by our method is very low—one cent or less per cell. SELFE & WHITEFORD.

Darlington, Md.

It is a matter of common knowledge that certain alkaline solutions such as salt and water, sal ammoniac and water, or vinegar and water, can be used to rejuvenate an apparently exhausted dry cell, but that the extra period of life thus obtainable is very short. We do not wish to cast any doubt on the correctness of your tests, but are willing to be shown, first, that the cells on which the solution was tried were absolutely exhausted beyond any possibility of recuperation by standing on open circuit, and, second, that when thus treated they produced an amount of current, or were good for an additional period of activity sufficient to make it worth while to thus treat them.

### GEARING ATTACHMENTS FOR FARM IMPLEMENTS.

Editor THE AUTOMOBILE:

[1,234.]—Have you any attachments for gearing a wagon with a gasoline engine, so I can run a wagon, a plow, or a harrow, or do general farming with? Or where can I get them?

Frederick, Okla.

JAMES CLAIR.

We do not make or sell automobiles or parts and cannot inform you offhand just where you can obtain the equipment you have need of. However, there are numerous manufacturers who make a specialty of such things and we have no doubt that immediately your letter comes to their attention through its publication in THE AUTOMOBILE they will correspond with you direct. Many farmers buy a clutch such as is ordinarily used on stationary gas engines, a pair of common sprockets and chains and rig their wagons up themselves, as this is not a very difficult matter for anyone at all handy with tools.

### EFFECT OF LENGTHENING THE STROKE.

Editor THE AUTOMOBILE:

[1,235.]—In reply to Mr. Frost's inquiry, No. 1,206, you say that "both the power and the efficiency of an internal combustion motor are increased by lengthening the stroke." While this statement is all right as to power, for the simple reason that power is the product of time, distance and resistance overcome, I do not think it is correct as to efficiency, at least in the ordinary type of explosion motor.

Efficiency depends upon the number of expansions attained by the charge, that is, the ratio of combustion volume (clearance) to stroke volume, and as the minimum relative volume of the combustion space is determined by the point at which preignition occurs from compression heat, or, in other words, is in a substantially constant ratio to the stroke volume, it follows that if the stroke be lengthened, the combustion space must be lengthened in the same ratio. Therefore there will be no gain in efficiency in a long-stroke engine unless it be in a slight degree, owing to the changed ratio of cooling surface in the combustion chamber, although this is problematical, because of certain factors having to do with the relative cooling power of cylinder-walls and piston-head.

I think it will be found that the principal reason why stationary engines have longer strokes is that their builders desire to get power at low speed (i.e. number of revolutions per minute), are not limited as to length and weight of engine, and have sought maximum durability. If one should attempt to increase the stroke of an engine having a given bore, and retain the same speed as before in the effort to increase the power, he would probably encounter some difficulties in the matter of increased inertia and centrifugal effects, besides the augmenting of length and weight.

That the efficiency of an explosion engine can nevertheless be considerably increased and a cooler engine secured by the simple expedient of charge-rejection during the early part of the compression stroke, is a fact which it is surprising to find is not more generally taken advantage of by four-cycle engine builders, although it has long been known, being embodied, for example, in the French Charon stationary engine.

To take care of the rejected portion of the charge in a single-cylinder engine involves some complication, but with multiple cylinders, and especially four and six cylinder combinations, the rejected portion simply goes back through the inlet manifold to the next cylinder, which is drawing in a charge, there being, therefore, no back-flow out of the carbureter, and the only change involved over present designs is a longer arc on the admission cams and a smaller combustion space. Such an engine would gain economy by expanding to a greater volume than that from which it begins to compress, its combustion space would have less radiating surface and involve better exhaust displacement, the engine would run cooler because of greater cooling by useful expansion, and the exhaust pressure would be reduced, with consequent less necessity for muffling and back-pressure. The inlet manifold is also kept warmer and complete vaporization of fuel promoted.

The specific power per unit weight of such an engine would probably be as great as or greater than present ones, and its maximum compression could be somewhat increased because beginning nearer the dead-center point. I feel confident that if engines were constructed on this principle, air-cooling would experience a considerable rise in popularity. Makers could then advertise their engines with perfect candor as being "internally cooled."

New York City.

R. M. PIERSON.

We do not agree with you in the statement that lengthening the stroke does not increase the efficiency, and think you go wrong on the assumption that lengthening the stroke necessarily means shortening or lengthening the combustion chamber proportionately. If we have a motor with a 6-inch stroke and a 2-inch combustion chamber, a similar motor can be designed with a 7 or 7 1/2-inch stroke and a 2-inch combustion chamber, and in operation it will expand the same volume from the same initial and explosive pressure, down to a much lower terminal pressure than would be the case where the stroke is only six inches. Short-stroke automobile motors exhaust at terminal pressures as high as 40 to 50 pounds per square inch, while stationary motors of good design get as low as 10 to 15 pounds per square inch terminal pressure. The utilization of the difference in pressure mentioned makes for greater efficiency and is brought about directly by the increase in the stroke.

Long stroke motors are necessarily of the slow-speed type, but this and amply proportioned parts make for durability, as a stationary engine is usually designed to work ten or twelve hours a day and about 300 days in the year with a minimum of attention. The gain in power and efficiency is naturally offset to a slight degree by the increased radiating surface presented to the hot gases. Altering the dimensions of the motor as outlined above would increase the ratio of stroke volume, or piston displacement, to combustion volume, and would necessarily permit of a greater expansion of the same volume of charge, on which our contention of increased efficiency is based. The question of pre-ignition need not be a serious deterrent factor in lengthening the stroke, as it is possible to keep the compression within safe limits by regulating the volume of fuel admitted.

We find your description of the Charon stationary motor interesting, and doubtless further work along this line may prove one of the developments of the future.

### EFFICIENCIES OF STEAM AND GASOLINE.

Editor THE AUTOMOBILE:

[1,236.]—I should be glad if you could inform me, through your columns, what is the average consumption of gasoline per mile in White steamers. Does it vary in the amount consumed according to the rate of speed? What is the loss in power of the gasoline car between the cylinder and rear wheels? What is the loss in the steam car from cylinder to rear wheels, and how do you account for said loss?

F. BARROW.

Chicago, Ill.

This is as low as six miles to the gallon and as high as thirteen; probably the average is about nine to eleven miles to the gallon of fuel. It naturally varies in accordance with the speed, as considerably more fuel will be consumed running at a low speed than at a much higher rate of travel. Every car has what may be termed its critical speed—i. e. the rate at which it is most efficient. In gasoline cars this has been found to be between twenty and thirty miles an hour, some being the most economical at twenty-five miles an hour, the increased amount of fuel at fifteen miles being almost 50 per cent., while the same thing is true when speeds of forty to fifty miles an hour are reached. At the lower speeds the excess is fuel wasted, while at the higher speeds it represents the extra amount required to propel the car at that rate.

Transmission losses vary in different cars, running as low as 15 per cent. and as high as 40 per cent., or even greater, and depending upon the age as well as the particular make of car, as gearing becomes much less efficient when worn. This, of course, has reference to the losses when on the direct drive, the clutch, universals and bevel drive being the chief points of loss. In the steamer there is the bevel drive and universals, so that the latter should naturally show a slightly superior transmission efficiency. In both cases the slippage at the road wheels and similar factors have been omitted from consideration as being the same in either case.

### INFORMATION WANTED ABOUT "ENERGINE."

Editor THE AUTOMOBILE:

[1,237.]—Will you please inform me if "Engerine," made by the Engerine Refining Company, is superior to gasoline and not harmful to an engine?

Where can I get a complete descriptive directory of all makes of automobiles in the United States?

C. F. WHEELER.

Vilas, Colo.

We have never heard exactly what substances were employed in the compounding of "Engerine," nor, on the other hand, have we had any occasion to doubt the maker's claims to superiority. This also applies to your query as to whether it is harmful to the engine or not, no instance of complaint on this score ever having been brought to our attention. We do not believe that there is any such directory published. However, we have compiled complete lists in THE AUTOMOBILE once a year, the last one

appearing in the issue just prior to the A. M. C. M. A. Show, held in the Grand Central Palace, New York, in October, 1907.

### A CASE OF CHAINS RATHER THAN SPROCKETS.

Editor THE AUTOMOBILE:

[1,238.]—I am having trouble with the front sprocket on my Rambler Model 21 automobile, and would like a little information about it. The sprockets furnished by the factory wear out every 1,500 miles. The factory insist that they are all right, both in material and design. They are made of soft steel, case hardened. I would like to know if a sprocket made from tool steel would be more durable, and if not, what other material would give better service? Is the mileage I get all that can be expected? Would it be advisable to put on a chain boot, and, if so, why do not manufacturers put them on in the first place? It is not only a lot of work, but quite an expense to make replacements so often, and it is not at all satisfactory to me.

PAUL F. FRANK.

Crestline, O.

Tool steel would not give anything like the service that can reasonably be expected from a case-hardened sprocket. It strikes us that the fault does not lie in the sprockets at all, but in the chains. The latter have become worn and are no longer of the proper pitch to suit the sprockets, which in consequence suffer from the chain's riding on the teeth to a greater or less extent, until the latter have worn away to a point where the distance between them is equivalent to that of the worn chain links, and then the sprockets are no longer fit for service. We think if you will replace the sprockets and the chain at the same time and will keep the chain properly adjusted you will have no further trouble on this score and that your mileage with a pair of sprockets will be greatly increased. A boot would save the chain if it could be kept oil-tight.

### SOME QUERIES CONCERNING TIRES.

Editor THE AUTOMOBILE:

[1,239.]—Kindly help us out with the following problem. While we have never read anything of the same order in "Letters Interesting and Instructive," we feel it would be interesting to all subscribers. Last summer we used a pair of the well-known leather treads on our rear tires and found it took about 1-8 of the power, beside the trouble of keeping them absolutely tight. We wish to know if you would advise us to put them on a new car which we have just purchased, before the treads get worn. As the car is quite heavy on the rear tires anyway, we are at loss to know where we are at. What would you do in this case? Also advise us if we can use Goodrich tires on Goodyear Universal detachable rims. We are ordering an extra tire, and prefer the Goodrich. If we can use them.

G. W. CURTISS.

Ravenna, O.

It depends upon what kind of roads you have to run over constantly whether it is worth while to consume as much as one-eighth of the power by using the leather, steel-studded treads. But a smooth tread pneumatic tire should always be kept inflated to a point where it is perfectly tight, so that one gives no more trouble on this score than the other. Goodrich or any other standard American tires can be used on the Goodyear rims, as the name "Universal" indicates. If the going is poor and apt to be slippery, doubtless the leather treads will be found well worth the extra amount of power they consume.

### A FEATURE OF THE RENAULT AEROPLANE MOTOR.

Editor THE AUTOMOBILE:

[1,240.]—In your last issue, March 5, I read an article on the Renault engine, to be used by Farman. In describing the pistons, it stated that they are fitted with a circular groove in their base, pierced with holes to prevent oil passing from crankcase into the combustion chamber. Would you kindly describe this method of fitting a groove in the pistons, as I am inclined to believe it would be a good thing on a large number of engines, if it would prevent oil passing from the crankcase to the combustion chamber.

Scranton, Pa.

E. J. HOWELLS.

This groove is turned in the piston near its lower end, and, with the exception of the holes, which are drilled clear through the wall of the piston, opening into the bottom of

the groove, it is the usual device employed for facilitating the oiling of the cylinder. This groove serves to catch the splash of oil in the crankcase and carries it up along the cylinder walls, and where an excessive amount is thus carried up it finds its way into the combustion chamber. In the Renault motor in question any excess is squeezed out through the holes.

### SOME QUERIES CONCERNING GASOLINE.

Editor THE AUTOMOBILE:

[1,241.]—In looking over your columns, I noticed quite a number of questions from the subscribers, and thought possibly you might help me out. I have had some trouble with gasoline. Although the gasoline I get registers seventy-six, it does not seem to bring results. What I want to know is whether gasoline can be adulterated, profitably, in such a manner as to have it appear, when tested with a gauge, to be seventy-six. The gasoline I am getting has a clouded appearance instead of being clear. I strain all my gasoline through chamomis, so it cannot be water that causes my trouble. I have had a good deal of experience with low-grade gasoline, and my car acts just like it was running on poor fuel. The car is practically new, and the carbureter is in perfect condition.

St. Louis, Mo.

B. G. V. C.

We never heard of a case where the gasoline had a cloudy appearance and are at a loss to say what such a condition can be attributed to. It may not be gasoline at all that you are getting, and we may add for your information that there is little, if any, gasoline of the lighter grades of gasoline now on the market, such as 76 degrees s.g. In fact, the Standard Oil Company announced some two years ago that it was compelled to abandon marketing the lighter grades owing to the very heavy demand. Procure some good fuel and see how the motor acts with it. Probably some of our subscribers have had similar experience and can help us out.

### QUERIES CONCERNING SINGLE-CYLINDER MOTOR.

Editor THE AUTOMOBILE:

[1,242.]—Being a subscriber to "The Automobile," I take the liberty of asking a few questions.

1. On a three-horsepower single-cylinder, four-cycle engine, would a mixing valve give a good mixture and good power at all speeds, and would the engine (with a 24-pound flywheel) be fairly flexible? Would I have to use a carbureter?

2. On the same engine—which is a jump spark—would an anti-vibrating coil be satisfactory, or would a vibrating coil be needed?

3. I have a small 6-volt dynamo with which I wish to spark this engine (after it gets going at a fair speed on batteries). Would I not need an automatic friction governor pulley on the dynamo to prevent it from burning itself or the coil out at high speed?

New York.

H. L. G.

1.—A mixing valve would give good service, but a carbureter would be better. The flywheel is very light, unless it happens to be of large diameter. Unless it measures more than twenty inches in diameter it would require about twice this weight to permit of the motor being throttled down to any extent.

2.—A non-vibrating coil gives excellent service provided the timing device is dependable.

3.—A governor is an absolute necessity on any dynamo where the speed is apt to fluctuate between such wide limits as is the case on a small high-speed engine. It will undoubtedly ruin both itself and the coil otherwise.

### LIGHTING SIDE AND TAIL LAMPS ELECTRICALLY.

Editor THE AUTOMOBILE:

[1,243.]—Will you kindly advise me, through your "Letters Interesting and Instructive," how one having an Apple dynamo and storage battery can light the tail and side lamps with the current? I find "The Automobile" very instructive as well as interesting.

Greene, Iowa.

J. COMPTON.

The lamps can be wired directly from the battery on a circuit independent from the ignition circuit, and, provided the battery has sufficient capacity to carry both without impairing the ignition, the service will be perfectly satisfactory. In fact, the makers of the apparatus in question advertise that this is one of its advantages and will supply full information regarding the manner in which the wiring is done.

### FOR BRAZING A CRACKED CYLINDER JACKET.

Editor THE AUTOMOBILE:

[1,244.]—I own a Reo runabout, Model B. Last fall, just before putting it away for the winter, I let the water freeze in it, which resulted in the bursting of the water jacket. I have had the opinion of several and find the best job can be done by brazing it. Could you refer me to some good, reliable firm that could do this? The jacket is cast iron and is a very nice thing to braze.

Lebanon, N. J.

E. B. SHURTS.

Look through out advertising columns and you will probably find the announcement of some firm that makes a specialty of doing such work. However, if the crack is not very large it may be possible to repair it without brazing or even removing the engine from the chassis. Clean out the entire fissure as much as possible, and with the end of a chisel or a file try to make the interior slightly larger than the surface opening. Make a paste of fine iron filings, salammoniac and water in the proportion of about 90 per cent. filings and 10 per cent. salammoniac. Fill the crack with this completely and pack it very tightly, putting considerably more on the outside than is really needed. Allow it to rust for a few days and it will doubtless be found to hold water. Ordinarily there is very little pressure on water-jacket walls, so that this repair should give no trouble.

### WANTED: SPECIAL VALVE-GRINDING COMPOUND.

Editor THE AUTOMOBILE:

[1,245.]—Will you please let me know whether there is on the market a substance for grinding valves other than emery or ground glass, and which, if accidentally introduced into the cylinder, will not score it?

In overhauling my engine, I find that the valves are in good shape and not at all pitted, but I should like to grind them in to insure tightness, and would like to use some such substance as indicated above.

A. G. HOUGH.

Batavia, N. Y.

There are numerous special compounds on the market for valve-grinding and you will find some of them advertised in our columns. Whether any of them have the quality of not scoring the cylinder walls when they come in contact with them, but of proving good abrasives when applied to the valves, is a hard question to answer, as mere location does not change the nature of a substance. However, some of them are put up in such form as to facilitate preventing any of the compound getting into the combustion chamber.

### TWO ASKING THE SAME INFORMATION.

Editor THE AUTOMOBILE:

[1,246.]—What kind of black top or leather dressing will be necessary, or what method will I have to pursue to make a red Pantasote top black?

READER.

Necedah, Wis.

Editor THE AUTOMOBILE:

[1,247.]—Kindly let us know through "Letters Interesting and Instructive" what is a good cleaner for Pantasote tops.

Charlotte, N. C.

OSMOND L. BARRINGER COMPANY.

A. W. McRae.

We will have to refer you to the manufacturers of Pantasote, as we do not know, nor have we ever heard that a material especially intended for this purpose was on the market.

### WATER DRIPPING FROM THE MUFFLER.

Editor THE AUTOMOBILE:

[1,248.]—I am using a two-cylinder car and notice when the motor is started that a few drops of water comes from the muffler. Can you tell me the cause?

J. C. SNYDER.

Metamora, Ill.

There is always more or less moisture in the air employed to make the explosive mixture. It vaporizes in the form of steam while the motor is running and escapes from the muffler, but when the engine comes to a stop there is some of it left in the cylinder, the exhaust passages and the muffler, and when these are allowed to get cold it condenses in the form of water. This is what you see issuing from the muffler when the engine is restarted.



**BEST ROUTE FOR TRANSCONTINENTAL TOURING.**

Editor THE AUTOMOBILE:

[1,249.]—Where can I secure a map of the best routes for transcontinental trips?  
A. R. M'LANE.

Prosser, Wash.

We would refer you to the May 16, 1907, issue of THE AUTOMOBILE, page 827, on which you will find an article entitled, "A Cruise Across the Continent," which is probably the most complete recent information to be had on the subject. We have also sent you particulars and map by mail. The only complete work extant on the roads of this country is the Official Automobile Blue Book of the American Automobile Association, but this as yet does not include any information on Transcontinental routes.

**WHO CAN IDENTIFY THIS MOTOR?**

Editor THE AUTOMOBILE:

[1,250.]—Kindly tell me through "Letters Interesting and Instructive" the name and manufacturer of an 18-20-horsepower two-cycle opposed water-cooled engine with valves in the head, mechanically operated, large square crank case, length over all about 49 inches by 14 inches, and large flywheel, 3 inches by 19 inches.

Sedalia, Mo. F. W. FISHER.

From the specifications you give we find it next to impossible to identify the motor you have in mind, as it is not customary to use a foot rule in examining a motor except where wanted to fill a certain space. Probably some of our subscribers will come to the rescue.

**GEAR RATIOS OF A 45-HORSEPOWER CAR.**

Editor THE AUTOMOBILE:

[1,251.]—What are generally considered as standard ratios of gear reduction for a 45-horsepower, water-cooled, shaft-driven touring car with sliding gear giving three forward speeds and one reverse?  
L. U. L.

Little Falls, N. Y.

Taking the Pierce Great Arrow, 1907 model, as a representative example of the American 45-horsepower car, the ratios are as follows: On the direct drive, 2.88 to 1; on the intermediate, 3.06 to 1; on the low, 3.26 to 1, while the reverse is slightly lower than the low forward speed.

**DENATURED ALCOHOL ON A SMALL SCALE.**

Editor THE AUTOMOBILE:

[1,252.]—I would like to have you send me a copy of the new denatured alcohol law, with information from which I can make a twenty-gallon still for its manufacture.  
G. H. FEATS.

Flint, Mich.

You can probably obtain this information by writing to the Department of the Interior, Washington, D. C.

**KEEPING THE CYLINDERS AND PLUGS CLEAN.**

Editor THE AUTOMOBILE:

[1,253.]—When I wrote you my experience with radium decarbonizer in my Ford Model N, I had no idea that there was such a need for just such an article. I know better now, and that is why I am writing this, for my brothers in trouble. I also know about the enormous circulation of your paper, "The Automobile," as nearly every mail since the publication of my article brings me pleadings for help on the lubrication question, asking what the decarbonizer is, and where it can be obtained. I am also made aware of the fact that there are readers of your most excellent journal who slight the advertising pages or they would find prominently displayed the advertisement of the radium decarbonizer people, even in the same issue as the one in which my few lines appeared.

In your last issue a correspondent asks a pertinent question as to kerosene oil and its effect on cutting other oils. I am glad he asked, as he did, for I did not make myself clear in letter No. 1,181. What I meant to say was "kerosene could be used at same time and would not soot up plugs or piston rings."

Now, for the benefit of all, I will give my experience for the past four months without looking at a plug. It is this: Twice a week I pour from a pint to a quart of cylinder oil, using Standard gas engine oil, which costs me 35 cents per gallon, into the breathing tube, or the upright pipe leading to the crankcase. After doing this I pour from 4 to 6 ounces of the decarbonizer into the same tube, screw down the cap and start the engine. A heavy, dark smoke will issue from the muffler, but will become lighter as engine gets hot; the plugs remain bright and clean. I also keep reservoir full of oil, with same proportion of decarbonizer, feeding about 20

drops to the crankcase and about 5 drops to the half bearing on main shaft per minute. I presume a higher grade of cylinder oil would require less of the decarbonizer.

The decarbonizer is put on the market to clean the cylinders, plugs, rings, mufflers, pipes, etc., when sooted and fouled up. When used in the manner indicated, it prevents the formation of carbon, and, so far as I know, I am the first person to use it as herein outlined. I have a very lasting and abiding impression of the trouble I used to have cleaning plugs and trying to regulate the oil supply, and now I have no trouble, so it seems to me the relation of my experience will not come amiss.

Milwaukee, Wis.

J. L. WILLIAMSON, M.D.

**CUTS OUT IGNITION TO SAVE MUFFLER.**

Editor THE AUTOMOBILE:

[1,254.]—I have been very much interested in the discussion of the proper method of using the motor as a brake, and especially so in that of No. 1,204, which takes up the question of whether or not it is best to cut out the ignition while coasting down a grade. The theory is advanced that cutting out the ignition saves the battery and thus saves expense. While this is undoubtedly true as far as it goes, it seems to me that there is another phase of the question which demands serious consideration, and that is the question of the collection of unburned gas in the muffler.

In driving several different makes of cars it has been my experience that, after coasting down even a moderately long grade, with the switch off, there is apt to be in the muffler a collection of unburned gas, which will be fired by the first explosion in the cylinder after the switch is turned on at the bottom of the hill. This has occurred in cases where closing the throttle while the car was standing would stop the motor, as mentioned in the article referred to, which fact shows that the quantity of gas drawn into the cylinder during any one charging stroke was very small. These gas collections and the subsequent explosions are very apt to result in a destroyed muffler, and in four distinct cases have, to my knowledge, resulted in this way.

Now, if the spark is left on while coasting down a hill, this gas will be burned as it comes into the cylinder, and, on account of its small amount, it will burn with almost no explosion and therefore will not materially detract from the braking power of the motor.

It has been my experience, and not with one make of cars only, that even though the throttle on some makes of cars is supposed to cut off absolutely the supply of gas, in most cases a small amount will leak past on each suction stroke, and these successive small amounts, when allowed to collect for the short time taken to run down a comparatively short grade, will form a collection large enough to produce the results described above.

It seems to me, then, that unless a man is some distance from home with batteries which he knows to be weak, the insurance against muffler explosions and consequent damaged mufflers more than overbalances the small saving in battery consumption.

I hope to see more discussion of practical problems of actual road running.

J. ARTHUR FISH.

Ithaca, N. Y.

**SOME HINTS ON GRAPHITE LUBRICATION.**

Editor THE AUTOMOBILE:

[1,255.]—In issue of March 5, you ask for "views of others on lubrication." It seems to me as though there should be no special fear of cutting or "seizing" of cylinders if a man will only get the "graphite habit." In my first machine, the Autocar, I began the habit of introducing graphite into the crankcase. In my next car, the Elmora, I kept up the habit, and followed the same habit with the Long Distance, the Reading Duryea and the Franklin—my last and best of all. In between I had two Stanley steamers, and graphite in the cylinders was a real necessity.

I introduced the graphite into the steam cylinders by means of a small hand-oil-pump attached to the steam pipe. This practice is all right with any steam automobile. As to how graphite may be introduced into the crankcase of a gasoline machine, no man with gumption need be told. In using graphite don't use over a teaspoonful to the pint of oil; you need no more. The graphite will not get up in the combustion chamber to do any harm. There need be no fear of its getting on to the spark plug. I have always used Dixon's 635, or motor graphite. This is a flake graphite, and the flakes build up all the microscopical irregularities on the bearing and wearing surfaces of pistons, rings, and cylinders, forming a graphite to graphite contact.

I have made use of the best amorphous graphite, but found that it formed into balls or pellets, and it doesn't withstand the great heat in the cylinder as well as flake graphite. When flake graphite is used in cylinders there will be better lubrication in cylinders, better compression, less oil needed, and greater satisfaction to the driver. There are many other places on the automobile where flake graphite will be found an important factor.

Jersey City, N. J.

NO. 126, NEW JERSEY.

## FEATURES OF THE STEARNS CAR FOR 1908

CONSISTENT adherence to a design that is the evolution of several years' experience and that has had ample opportunity to demonstrate its merit, marks the Stearns cars for 1908, and this applies not alone to its power plant, but to the entire chassis, including every one of those distinctive features of design and construction that have become familiar as earmarks of the Stearns product. For this season the four-cylinder car is a 30-60-horsepower car with cylinders having 5 $\frac{3}{8}$ -inch bore and 5 $\frac{7}{8}$ -inch stroke. Coupling it with the rear wheels are an expanding clutch, four-speed selective gear-set and a side chain type of drive. The car has anti-friction bearings throughout, having no less than forty-four DWF bearings, distributed as follows: Wheels, eight; transmission, thirteen; motor, ten; fan, two; clutch, three; steering parts, four, and magneto, four. In the motor, three ball races carry the crankshaft and four carry the camshaft. The improvements as compared with the 1907 machine include carbureter refinements, new motor accessory arrangements, transmission improvement and some steering gear changes.

The Stearns four-cylinder motor resembles in general layout the 1907 one, in that its cylinders are cast in pairs with valves in an integral chamber on the left side and opened by direct lift from a camshaft within the crankcase. The cylinder castings are made without heads for the water jackets and take large oval plates instead. While this part of the design is as a year ago, great changes have been made in the arrangement of the water pump, oiler, timer and magneto. The water pump is carried within the left front motor arm, its position being a very unusual one, as indicated at *WP* in the right side engine illustration, as well as in the front view of the motor. Standing beside the engine, it cannot be seen, its location being indicated, however, by the pipe *WI*, which leads from the top of the motor support arm to the water jackets on the valve side. The crankcase is cast with a bedplate across its forward end, which forms a support for the radiator, thereby taking the radiator entirely

away from the chassis frame and making it a unit with the motor crankcase, thus relieving it of all torsional strains.

This construction brings the radiator and pump so close together that a hose connection between them is unnecessary, the only tubing essential being an elbow from the base of the radiator to an opening *W2*, whence the crankcase is drilled to the losing of the water pump. To remove the water pump, which is on a separate shaft, it is but necessary to remove a large diameter cap threaded into the rear face of the motor arm containing the pump. At the right side of the motor appears another example of what use can be made of the supporting arm. A multi-feed Lavigne oiler *L* has its casing the aluminum supporting arm, just as the water pump has its casing the supporting arm on the opposite side. A separate shaft gear-driven through an idler from the crankshaft, drives the bank of pumps in the oiler and has on its rear end a jaw coupling *J* for connection with the magneto. On the shaft is a helical gear for driving the short vertical shaft of the timer *T*. This arrangement gives a most compact grouping of the oiler, timer and magneto, and leaves ample room for the steering gear, the lower portion of the column of which appears in the rear of the magneto. The magneto rests on a bed plate which fills the rectangle between the crankcase, the frame and the front and rear motor-supporting arm.

The Stearns crankcase is a one-piece casting instead of the conventional upper- and lower-half case, and because of this the crankshaft, camshaft and other motor shafts must be removed endwise through the front of the crankcase, and when removed the bearings and their bushings are removed with them. This is accomplished in the following manner: The rear bearing of the camshaft is held direct in the end of the crankcase; the second bearing has a bushing; the third bearing has a bushing of greater diameter than the bushing on the second bearing; and the fourth bearing has a bushing larger than either of the other bushings. In removing the camshaft these bushings

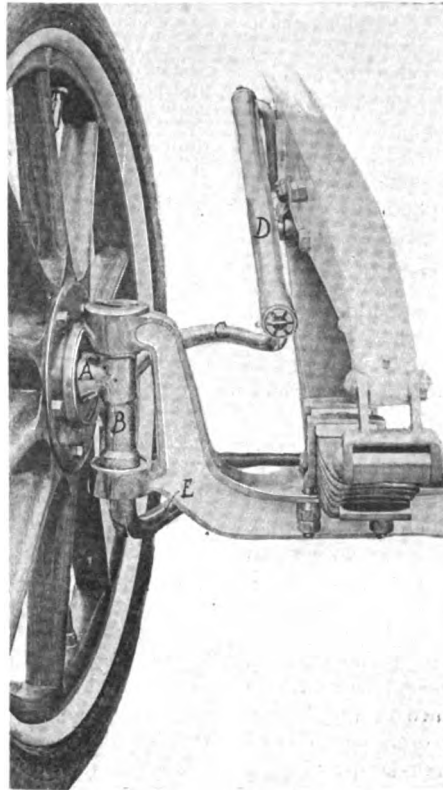

Stearns Improved Draglink Connection.

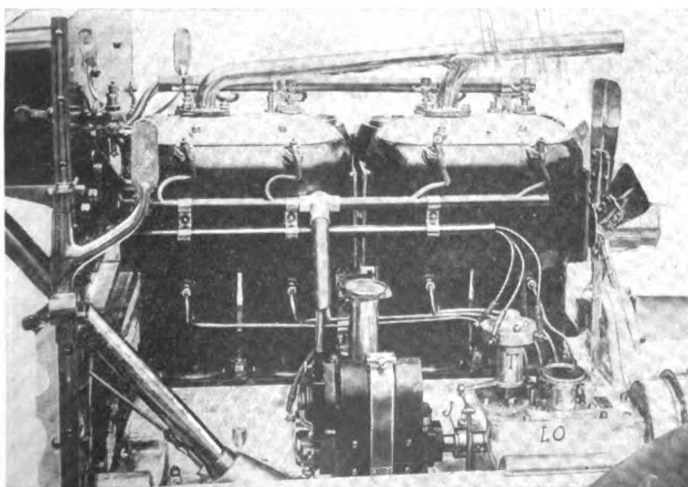

Exhaust Side, Showing Oiler and Magneto Drive.

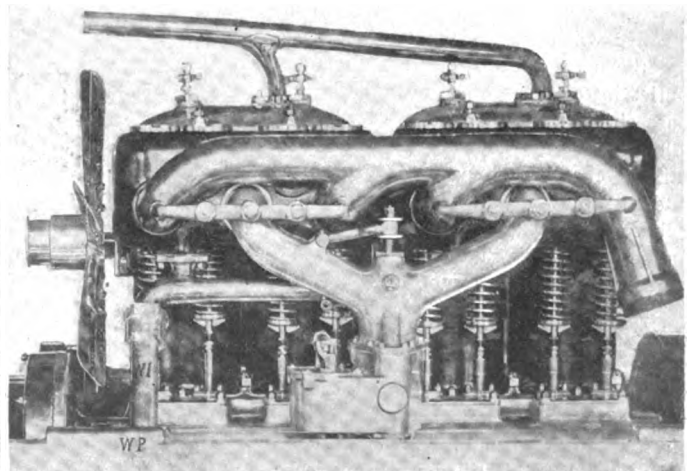

Operating Side of Motor, Showing Double Carbureter.

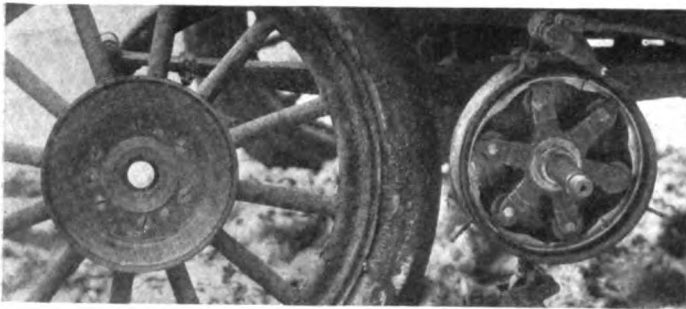

**Bronze to Steel Emergency Brake and Its Housing.**

are removed with the bearing and the shaft, so that the opening in the front end of the case is of sufficient size to let the remaining bearings, with their bushings, pass through with ease. The same practice is followed with the bearings for the crankshaft. The compression release scheme, to assist in starting, consists of a set of four relief cams on the camshaft, operated by the movement of a rod by a pull at the base of the radiator.

#### **Details of the Stearns Fuel System.**

The most striking evidence of the painstaking attention that has been paid to every detail of the Stearns car is to be found in the carbureter, which is an evolution that is the product of two or three years' study. Its basic principle of design is that of providing a varying amount of fuel as well as air, in accordance with the power required of the engine, this being a development made necessary by the demand for large and powerful motors. It was found imperative to depart from currently accepted designs in order to accomplish this result, and as a matter of fact nothing on the car has received more attention than the carbureter, to which the designer attributes no little part of the smooth running of the motor. It is of the twin-nozzle type, the smaller nozzle, which has a fixed opening, located in a mixing chamber of its own, generating up to 30 horsepower, the larger nozzle having two orifices and being brought into use when power and speed above that furnished by the smaller one only are required. This carbureter offers four methods of control over the mixture, all of which are mechanically effected from a lever on the steering wheel. The controls are, briefly, as follows:

First, to keep the motor just turning over when the car is standing. Air enters through a fixed air opening. This air rising past the nozzle, passes up through a tube and then through a small opening regulated by a cone tipped adjusting screw; thence it finds its way to the motor. The exact amount of mixture permitted can be regulated by the adjusting screw.

Second—When starting the car, after it has been standing by the curb with the engine running, a plunger is depressed by means of the control from the steering wheel. Depressing the plunger opens a valve which allows the mixture passing the main nozzle to follow the main outlet instead of going through the by-pass channel, as in the first case. This allows the full capacity of the small mixing chamber to pass to the motor, and to supply air for this the automatic valve is brought into action. With this arrangement it is possible to secure 30-horsepower from the motor.

Third—Should still more power be demanded, the plunger is further depressed. This opens a valve and immediately the big nozzle is brought into action in that the motor suction brings air past the large automatic valve.

Fourth—Should still more mixture be desired, the plunger is depressed still further, until it forces the expanded end

of it upon the top of a tubular stem of a special valve in the upper part of the larger mixing chamber, and opens this valve, thereby giving the maximum amount of mixture to the cylinder.

The expanding clutch which has been used on Stearns cars for several seasons has been retained intact. There are two expanding shoes in this clutch, each being semicircular and secured at one end to a fixed piece and at the other end to a swinging support. The expanding shoes are leather faced.

#### **Ball Bearings Throughout Transmission.**

In the Stearns gearset the use of a four-speed selective set with direct drive on the fourth speed is continued. This gearset remains practically as it was in 1907, except for change in the design of the case to give compactness and add strength. In all, thirteen DWF bearings are used. A universal coupling is interposed between the clutch and gearset. Side-chain drive is continued, and the adjustment of the chains consisting of a radius rod, swiveled at its rear end of the axle, and hinging at its front to a member with a spur to which the rod attaches. Threaded into this sleeve is a rod which is adjusted by a nut and locknut. One of the illustrations shows the expanding shoes of the emergency brakes, which are bronze segments that act against the interior force of the steel drum on the wheel.

The improvements in the running gear largely center around the steering knuckle, although the frame has been dropped 2 1-2 inches in front of the rear axle to give a lower body carriage; except for this the side members are straight from end to end. In the steering knuckle the great change is the forging in one piece of the spindle *A* for carrying the wheel, the hub portion *B* forming the pivot, the arm *E* with ball end for connection with the tie rod to the opposite knuckle and the knuckle arm *C*, which connects to the draglink *D* that couples with the steering gear. New also is the use of the DWF bearing in the top of the knuckle, which carries the weight of the car. After making these four parts, *A*, *B*, *E*, *C*, integral, it was necessary to make the opening in the lower end of the axle jaw of sufficiently large diameter so that the hub *B* could be pushed through the opening until the top of the hub was free to enter the opening in the top of the jaw. Bushings are used for filling the extra space in the lower arm of the jaw. The steering gear has been improved by increasing the strength and size of all its parts. It is a worm and pinion gear, and is supported on the bedplate which carries the magneto. A pronounced improvement consists of carrying the draglink *B* high and outside of the frame, so that it parallels the side member, thereby occupying a position of safety.

A critical examination of the design and constructional details of this year's representative of the Stearns is strongly indicative of an advanced trend, particularly where the motor is concerned, simplicity and compactness forming the keynote throughout, as is evident from the manner of placing the accessories, the radiator mounting being a particularly noteworthy feature.

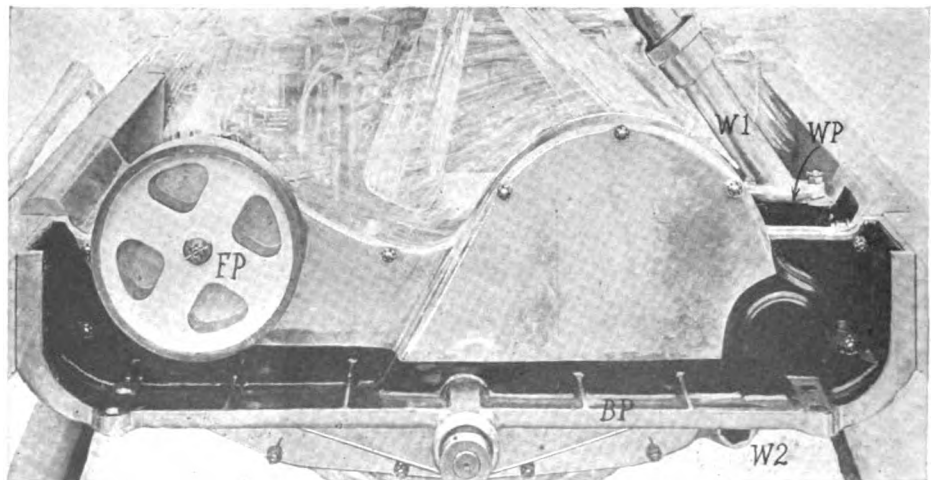

**Novel Arrangement of Water Pump and Lavigne Oiler.**

# A TWO-DAY TRIP IN SOUTHERN CALIFORNIA

PASADENA, CAL., March 11.—There were just thirteen in the party, and two Packard "30's" were utilized for the 207-mile jaunt. The presumably unlucky total number of tourists, however, had no effect upon the spirits of those participating, and the weather was such as only California can produce in February. It was a quiet, domestic tour, the families of J. M. Murdock, of this city, and L. S. Hackney, of St. Paul, Minn., making up the party.

Start was made for the two-day trip on a Friday morning and a southeasterly course was taken, with Riverside as the goal of the first day's run. A St. Valentine's day lunch (for it was February 14) was eaten in the open, when the noonday halt along the road was made, and the picknickers are the subject of the first snapshot which illustrates the story. The next picture below and the one in the lower right-hand corner of the page show both the Packards in action as they forded a small stream near Arcadia, some miles out on the first day's journey.

The road to Riverside skirts the foot-hills of the San Bernadino range, some 30 miles to the east. Riverside is the head and center of one of the richest orange-growing sections in the world, and the county seat of Riverside county. It is 65 miles east by south from Los Angeles, and is noted for its beautiful streets and surroundings. Here the party stayed over night at the Glenwood Hotel, and next morning started from the Mission Garage, for Redlands, High-

lands, San Bernadino, and home. The winding road up Huntington drive on Mt. Rubidoux was taken out of Riverside, and two of the illustrations show the cars on the route. A photo of the party was taken at the summit of the mountain. As the road approaches the city of San Bernadino the mountains increase in grandeur, and the scenery is magnificent. The city which stands near the site of an abandoned Spanish mission of the same name has a bit of interesting history as a municipality. It was founded by a company of Mormons in 1851, who wished to establish a way station for the emigrants to Utah by way of the Pacific route. It was incorporated in 1854, but on the withdrawal of the Mormons,

in 1857-58, its importance declined so rapidly that it was dissolved in 1861. In 1863 its charter was restored. The population has increased rapidly, until now it numbers about 7,000 souls. The town is also noted for its mud baths.

The route of the trip carried the party into three counties. Counties in Southern California mean more in dimensions than they do in the Eastern States. San Bernadino is the county seat of the county of that name, the largest in the State, covering an area of 19,947 square miles, and extending from the city of San Bernadino, which is situated in the southeast corner, to the Colorado river, almost 200 miles away to the east, and north about 110 miles, to the Inyo county line. Practically all that is inhabitable of San Bernadino county is the southwest corner, west of the mountain range. The rest is desert land, hot and dry, the Mojave desert and sink of Mojave occupying a great part of the vast area.

Riverside county is also a garden spot in the western part and a desert in the east. It is about 40 miles broad from north to south, and borders San Bernadino county on the south its entire length. The county of Los Angeles, however, secured the bulk of the trip. It is the real "American Italy," the paradise of the tourist, and the ideal home of the all-the-year-round automobilist. If there is any touring ground the world over that can surpass Southern California in anything but the matter of roads we have yet to find it, and the countless hundreds who make an annual pilgrimage across the ocean to enjoy the delights of French and German scenery and historic resorts, will find a vast amount to interest them here at home, if they only knew it. Of course, there are not the miles and miles of straight and level highways that distinguish Continental Europe, where lenient regulations make "letting her out" a delight that can be indulged in on every occasion that the reasonable handler of the wheel could possibly desire to do so. This is a drawback, but this part of California can never have such roads, regardless of the amount she is willing to spend on improvements and construction, as the country is much too mountainous.



Typical and Picturesque Scenes Along the Route of a Two-days' Tour in Southern California.



## BOOKS FOR AUTOMOBILISTS.

**Ignition Troubles; Effects, Causes, Etc.**—This is the title of a booklet from the pen of Harry Eisner, E.E., of Boston, Mass., who has treated the subject in a concise and clear manner, so that the man who has had no experience whatever can understand the subject matter and follow it by means of the numerous standard wiring diagrams which form part of the work. Every form of ignition apparatus at present in current use is briefly touched upon. The pamphlet is being distributed by the Gordon Automobile Supply Company, Inc., 1024 Boylston street, Boston, Mass.

**An Automoblist's Diary.**—Of a convenient form, carefully compiled and well produced, the Automoblist's Diary and Reference Book for 1908, from Case & Hechinger, Boston, should be well received by the touring automobilist. A tabulated table is given for each day of the year, with blanks for filling in such matters as are likely to be useful or interesting for future reference. In a small form there is a mass of information valuable to all drivers of a car. The diary is well bound in leather.

**A Romance of the Automobile.**—In eight honks and one crash, Julian Street paints with considerable skill a picture of his first motor experience, in a publication from the John Lane Company, New York, entitled "My Enemy the Motor." It is a somewhat grim sort of a romance—if grimness and romance can be associated—but the telling of it is well done, the locale excellent and the illustrations an embellishment. Mr. Street is now driving his second Locomobile, and lives at Greenwich, Conn.

**Curing Automobile Diseases.**—In the hands of the automobile doctor the disease of the gasoline-propelled vehicle appear to multiply as rapidly as ills of the flesh. Certainly A. L. Dyke in his "Diseases of the Gasoline Automobile and How to Cure Them" has unearthed enough to satisfy the most rabid trouble hunter. The book is obtainable from the Phoenix Supply Company, St. Louis, Mo.

## TESTING CARS UNDER WINTER CONDITIONS.

Heavy snowfalls add to the work of both the tester and the car which is being put through its initial work-out on the road, but that they do not deter either from undertaking their daily round of work is evident from the accompanying photograph showing a couple of Premier testers, a few miles from the Premier factory in Indianapolis. Contrary to the usual order of things during the past few months, the Premier Motor Manufacturing Company has been running its entire plant in full swing, and has even found it necessary to do a great deal of overtime work so that the reasons for putting cars to the test as fast as they were turned out will be apparent.



Testing a Premier on Indiana's Snow-covered Roads.

## THE AUTOMOBILE CALENDAR.

### AMERICAN.

#### Shows and Meetings.

- Mar. 18-24.....—New Haven, Conn., Music Hall, Annual Show, New Haven Automobile Dealers' Association.
- Mar. 21-28.....—Toronto, Canada, St. Lawrence Arena, Automobile Show. R. M. Jaffray, manager.
- Mar. 23-28.....—Indianapolis, Ind., Annual Show, Automobile Dealers' Association.
- Apr. 4-11.....—Pittsburgh, Pa., Duquesne Garden, Annual Show. Automobile Clubs of Pittsburgh. Thomas I. Cochran, manager.
- Apr. 5-12.....—Montreal, Canada, Arena, Third Annual Automobile and Sportsman's Show. R. M. Jaffray, Mgr.
- Apr. 6-8.....—Denver, Mammoth Rink, Annual Automobile Show. G. A. Wahlgreen, manager.

#### Race Meets, Hill Climbs, Etc.

- Apr. 6-10.....—New York City, Automobile Carnival, Illuminated Parade, Hill Climb, etc., New York Automobile Trade Association.
- Apr. 24.....—Briarcliff Trophy Race, Westchester County, N. Y. Robert L. Morrell, chairman.
- May 4-5.....—Harrisburg-Philadelphia and Return, 300-mile Endurance Run, Motor Club of Harrisburg.
- May 15.....—Chicago, Algonquin Hill Climb, Chicago Motor Club.
- May 16.....—Hartford, Conn., 200-mile Endurance Run, Automobile Club of Hartford.
- May 30.....—Bridgeport, Conn., Sport Hill Climb, Bridgeport Automobile Club.
- June 24-27.....—Chicago, 1,200-mile Reliability Run, Chicago Motor Club.
- July 6-8.....—Buffalo, National Convention of the A. A. A., and Start of Fifth Annual Tour.
- Sept. 14.....—Chicago, Annual Economy Run, Chicago Motor Club.

### FOREIGN.

#### Shows.

- Mar. 21-28.....—London, Agricultural Hall, Cordingley's Show.
- Mar. 28-April 6.—Paris, Alcazar d'Ete, Small Inventors' Exhibition.
- Mar. 26-April 4.—London, Olympia Industrial Vehicle and Motor Boat Show.
- May 17-31.....—Austria, Budapest Automobile Show.
- May 17-June 2.....—Moscow, Russia, International Automobile Exposition, Automobile Club of Moscow.
- December.....—Paris, Eleventh Annual Salon de l'Automobile, Grand Palais, Automobile Club of France.

#### Race Meets, Hill Climbs, Etc.

- April 1-13.....—Monaco Motor Boat Races and Motor Boat Exhibition, International Sporting Club of Monaco.
- April 25-May 25—Industrial Vehicle Competition, Automobile Club of France.
- May.....—Paris, Competition for Agricultural Automobiles, auspices of "L'Auto." (Date to be announced.)
- May 7.....—Sicily, Palermo, Targa Florio Circuit, Volturette Race, Automobile Club of Italy.
- May 11-16.....—Ireland, Irish Reliability Trials.
- May 1-31.....—Automobile Taxicab Competition, France, Automobile Club of France.
- May 10.....—Sicily, Targa Florio, Automobile Club of Italy.
- May 31.....—Russia, St. Petersburg to Moscow Race.
- June 1-18.....—Reliability Trials for Pleasure Cars, Automobile Club of Great Britain.
- June 9-17.....—Touring Competition for the Prince Henry of Prussia Prize, Germany, Imperial Automobile Club of Germany.
- July 6.....—Volturette Grand Prix, Dieppe Circuit (Automobile Club of France).
- July 7.....—Grand Prix of Automobile Club of France, Dieppe Circuit.
- July 13-17.....—Ostend, Belgium, International Race Week, Automobile Club of Ostend.
- July 20-30.....—Ardennes Circuit Races and Coupe de Liedekerke, Automobile Club of Belgium.
- Aug.....—France, Coupe de la Presse, Automobile Club of France. (Exact date to be announced.)
- Aug. 29-30.....—France, Mont Ventoux Hill Climb, Vauclusien Automobile Club.
- Sept. 1-8.....—French Volturette Contest, auspices of "L'Auto."
- Oct. 11.....—Berlin, Germany, Gordon Bennett Balloon Race, Aeronautical Club of Berlin.

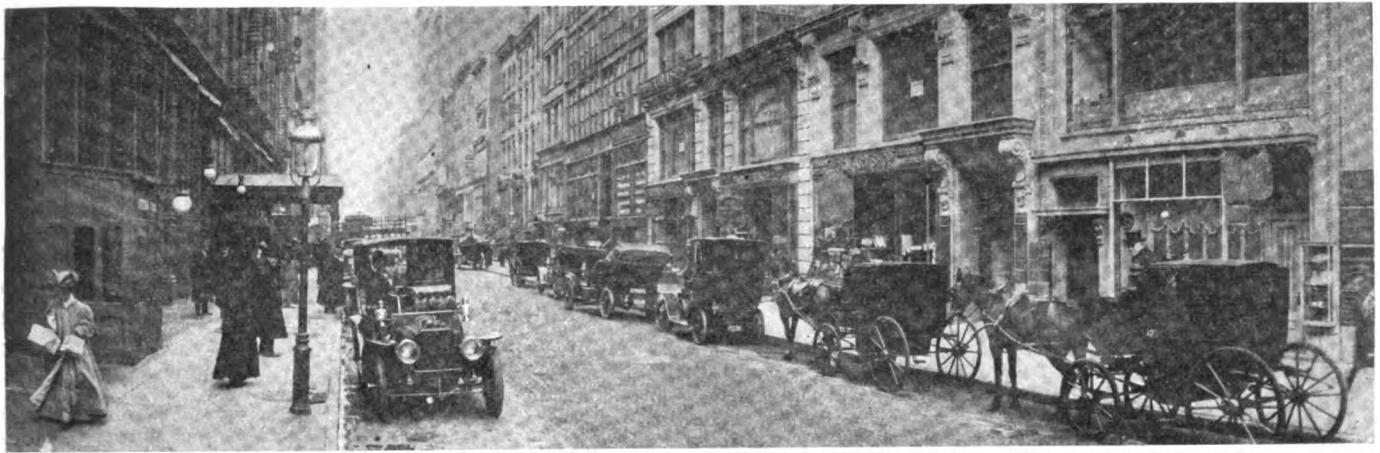

Ever-increasing Use of the Automobile as Evidenced by the Daily Scene in Dry Goods Shopping District of New York City.

## CONVICT LABOR FOR ROAD BUILDING IN THE CAROLINAS

By F. S. SLY, TRAVELING CORRESPONDENT OF THE AUTOMOBILE.

CHARLOTTE, N. C., March 11.—There are about 125 cars in this city, and it has just received its first automobile truck, which is a Franklin, sold by O. L. Barringer recently to the General Fire Extinguisher Company.

There has been some talk of getting together and organizing a club, but as yet nothing has come of it, though the majority of the individual owners are enthusiastic autoists.

Here, as everywhere else in North Carolina, the county is using its convict labor to build macadam roads, and about 100 miles have already been constructed. The clay roads are very good in summer, but in wet weather they become almost impassable.

The dealers are O. L. Barringer, who handles the Franklin, Autocar, Cadillac, White, Pope-Waverly and Buick; the Charlotte Motor Car Company, who have the Ford, Rambler and Reo, and Hans and Ross, who represent the Maxwell. The first two firms are the only ones here maintaining garages.

SPARTANBURG, S. C., March 12.—This city claims to have more paved streets than all the other cities in South Carolina combined, and it certainly has many miles of fine pavement. For several years past Spartansburg County has been building about five miles of macadam road annually with convict labor, and, in addition to continuing this program, is now planning a

bond issue of \$200,000 to further the work of road improvement. Here, as elsewhere in the State, the soil is clay and becomes very bad in wet weather.

In the city itself there are about sixty cars, and F. S. Bryant is probably the most progressive autoist here, no club having been formed as yet.

The only garage is maintained by the Spartansburg Automobile Company, representing the Ford line.

GREENVILLE, S. C., March 13.—Although this city has a smaller number of cars than either Charlotte or Spartansburg, only being able to boast of fifty-five all told, it already has an automobile club, known as the Greenville Automobile Association, of which Perry Beattie is president; A. P. Hoke, secretary, and R. N. Tannehill, treasurer. At present the membership is thirty, and as Mr. Tannehill says the prospects are bright for a large number of sales this year, the future of the club is correspondingly so.

Garages are maintained by the Barr Hardware Company, representing the Maxwell, and R. N. Tannehill, handling the Franklin and Buick, while Nugent F. Bates represents the Cadillac. The roads are good in summer, and as is the case with neighboring counties, convict labor is being employed for their improvement.

## LOUISIANA LEAGUE TAKES UP ROAD CONSTRUCTION WORK

NEW ORLEANS, March 16.—Local auto enthusiasts now realize that it is the lack of good roads throughout the South that prevents them from getting the much-coveted Glidden tour. To this fact alone they attribute their failure to get the 1908 tour. But if good roads will bring it, the Automobile League of Louisiana is taking the proper course, for they have started a campaign for better roads.

A movement has now been started to have the road between this city and Baten Rouge improved and placed in shape for traffic of all sorts. This road, which follows the Mississippi River, is one of the most picturesque in the State and would make an ideal course for short tours. The road is 125 miles long and without any great expenditure of money could be placed in excellent shape. To have this accomplished is now the aim of the Automobile League.

Last week a trip was made to Baten Rouge by a party from this city, headed by Palmer Abbott. The trip was made in the famous "Mudlark No. 3," which recently completed a tour from New York City to the Crescent City. For the first thirty-five miles out of this city they encountered all sorts of difficulties,

the road being in horrible shape. This was caused by the moving of the levee back, and the road is merely a trail through the plantations. The remainder of the road is in fairly good shape, being kept up by the plantation owners, all of whom are more than anxious that the whole road be improved.

Some time next week a party, composed of Palmer Abbott, G. E. Demack, Dr. Joseph M. Woodward and Dr. R. E. DeBuys, will start out in several machines and make this trip, visiting each parish. The authorities in each parish will be interviewed and asked to co-operate in the plan to improve the road, especially the first thirty-five miles out of this city, where it is in a horrible condition. The members of the various levee boards will also be seen and asked to do their share of the work.

"About all that is needed," said Mr. Abbott, "is to drain the roads on both sides with ditches and to run a traction engine over the roadway in order to smooth it. The matter will be pushed vigorously and local enthusiasts hope to have the road in excellent shape by the middle of the summer. This is not the only road that the Louisiana Automobile League have in mind, but they are going to make it a general State movement."



Vol. XVIII Thursday, March 19, 1908 No. 12

THE CLASS JOURNAL COMPANY

Flatiron Building, Madison Square New York City

H. M. SWETLAND, President

EDITORIAL DEPARTMENT

A. G. BATCHELDER, Managing Editor
R. F. KELSEY, Associate Editor C. B. HAYWARD, Engineering Editor
W. F. BRADLEY

BUSINESS DEPARTMENT

A. B. SWETLAND, Business Manager
LOUIS R. SMITH FRANK B. BARNETT
W. I. RALPH, 1035 Old South Building, Boston, Mass.
C. H. GURNETT, H. E. WESTERDALE, 836 Monadnock Block, Chicago, Ill.

Cable Address Autoland, New York
Long Distance Telephone 300 Gramercy, New York

SUBSCRIPTION RATES:

United States and Mexico One Year, \$3.00
Other Countries in Postal Union, including Canada One Year, 5.00
To Subscribers—Do not send money by ordinary mail. Remit by Draft, Post-Office or Express Money Order, or Register your letter.

FOREIGN SUBSCRIPTION AGENTS:

ENGLAND:—Hilffe & Sons, Limited, 29 Tudor Street, London, E. C.
FRANCE:—Boyveau & Chevillet, 22 Rue de la Banque, Paris.
GERMANY:—A Seydel Mohrenstrasse 9, Berlin.

Entered at New York, N. Y., as second-class matter.
The Automobile is a consolidation of The Automobile (monthly) and the Motor Review (weekly), May, 1902, Dealer and Repairman (monthly), October, 1903, and the Automobile Magazine (monthly), July, 1907.

Table with 2 columns: Copies printed in, Amount. Rows for 1905 (730,000), 1906 (791,000), 1907 (888,900).

NO SINGLE CLUB CAN CONTROL HERE.

Obsessed by a name which has become misleading, vainly trying to have the club what it is not and never can be, a few now in control of the Automobile Club of America, finally disgruntled because its spokesman could not dictate the policy in legislation and other matters of the New York State Automobile Association, has seen fit to decree its resignation from that organization, which high-handed action also carries with it the severance of all relations with the American Automobile Association.

Recognizing the patent fact that only through local, State and national action can there be secured those things which add to the progress and enjoyment of automobiling, the growth of the American Automobile Association under the existing administration has been substantially cumulative. In union there is strength, but if the clubs of a State worked as separate units, and, inevitably, often at cross purposes, there would be little accomplished and results would be few and far between.

In France the Automobile Club of France, with headquarters in Paris, does "lord" it over the clubs of the provinces, and in Great Britain the Royal Automobile Club, located in London, is attempting to do the same thing, after a break with the Motor Union of Great Britain and Ireland, with indications that its plans will go decidedly amiss; in fact, negotiations are in progress for a readjustment of differences. But foreign procedure is seldom successfully transplanted to these democratic United States, and this was quickly demonstrated at Chicago in March, 1902, when the clubs there assembled—

Chicago Automobile Club, Automobile Club of New Jersey, Long Island Automobile Club, Rhode Island Automobile Club, Automobile Club of Philadelphia, Princeton University Automobile Club, Automobile Club of Utica, and the Grand Rapids Automobile Club—emphatically declined to accept the A. C. A. of New York City as the fountain head of government, although the Automobile Club of America was represented at the meeting. At that time A. R. Shattuck was the president of the A. C. A., and annually he visited Europe, and, perhaps, brought back ideas that he thought deserved transplanting.

But the American Automobile Association was born at Chicago with all clubs on an equality—each club casting its total membership vote and no more. In its early years the A. A. A. progressed spasmodically, always subjected to the scrutiny of those who would not have it interfere with the ultimate hope of A. C. A. supremacy. Several administrations of A. A. A. affairs gave little except unfulfilled promises and some dissensions that threatened its very existence.

Then came the Hotchkiss era and a leader surcharged with determination and enthusiasm. He took up the work the others had thrown down. Previously he had raised the New York State Automobile Association to a high degree of perfection—accomplishing it without any considerable aid from the inner circle of the A. C. A., for, let it be kept in mind, the members under a constitution which has been gradually "perfected" are not required to bother much with the conduct of the club. The self-perpetuating governors do that with an expertness which has earned the admiration of politicians.

Still nursing that deferred desire to "nationalize," the strongly entrenched clique of the A. C. A. has watched with unfeigned jealousy the growth of the A. A. A. into a national organization of dignity and far-spreading influence. An effort was made to get control of the Vanderbilt Cup, but its frank and fair-minded donor let it be understood without hesitation where he stood on that proposition. To this event—established mainly through the energy of the indefatigable Pardington—the A. A. A. owes much, for the race's 1905 and 1906 surplus furnished the financial sinews for carrying on the work of education and organization—a better use for the money than investing it in a big clubhouse.

It is well remembered by New York State autoists how they were nearly forced several years ago to accept a most obnoxious law, how Mr. Shattuck was "thanked" for his services at Albany, and then another committee undid what had been almost done. Once more we find Mr. Shattuck "legislating" at Albany, and now, despite the action of the State association on which his club had a member, we find this industrious automobile patriot insisting that larger fees should be paid than those contained in the bill of the State association. Of course, President Quayle resented this meddling, whereupon there followed the resignation of the A. C. A., thus indicating that that club is Shattuckian governed and consequently useless except as a means of employing the time of that self-absorbed toiler who at least deserves the credit of being honest in his misdirected endeavors.

But the A. A. A. will go on with its work, for it is founded in the needs of the hour. The A. C. A. may be rescued from ring rule, for many members are at variance with the present suicidal policy. Time alone will tell the story.

## A. A. A. EFFORT FOR FEDERAL REGISTRATION

WASHINGTON, D. C., March 16.—Legislative hearings often mean nothing; their purpose frequently is to deceive rather than to enlighten. The session on Thursday last before the Judiciary Committee of the House of Representatives, with the Federal Registration Bill of the A. A. A. as the topic of discussion, was a hearing seldom seen, according to the opinion of experienced observers, and the masterly presentation of argument in behalf of the measure was undeniably brilliant, logical and grudgingly convincing to lawyers sharpened by contact with all manner of constitutional problems. Charles Thaddeus Terry, chairman of the A. A. A. Legislative Board, counsel of the National Association of Automobile Manufacturers and professor of law at Columbia University, was the man who bore the burden, concisely putting forth the claims of the proposed law, accepting with evident enjoyment the repeated assaults that came to him across the committee table and never losing his equanimity even when the questions were plainly intended to destroy the continuity of his really wonderful marshalling of the facts in the case. Chairman Jenkins, of Wisconsin, is understood to be a stickler in conforming to the Constitution, and at times it seemed to the automobilists that he was searching more for material to sustain his own deductions rather than to learn on what grounds the automobilists sought the right to go anywhere in this country after informing the Federal government that they had complied with the laws of their own States, and thus obtain a national passport.

The hearing was opened by President Hotchkiss, who briefly pointed out the necessity for interference on the part of the Federal government to protect the motorists of the nation while operating in those States which require the registration of non-residents and use the requirement as a means of taxation.

### Chairman Terry Ably Presented His Argument.

The principal argument was made by Chairman Terry. It was practically conceded by the committee that legislation of the kind asked for was necessary, and that it should be accorded if Congress had power under the Federal Constitution to regulate the registration of motor vehicles when operated in States other than those of their owners' residences. It was apparent at the outset that the question being an entirely new one, and the powers of Congress being necessarily limited to its control over commerce between the States as granted to it by the Constitution, and as construed by the commerce decisions of the Supreme Court, the problem to be solved was whether Congress could in any way regulate the use of a pleasure vehicle, when operated on the highways of a State other than the State of the owner's residence; in other words, when engaged in interstate travel. It was apparent, also, that most of the members of the committee had grave doubts as to such travel being within the meaning of the word "commerce" in the Constitution. Hence, when it is stated that after a two hours' presentation by Mr. Terry, several members of the committee stated that while they had been very doubtful, they had been either wholly or almost convinced that Congress had the power to pass the Cock's bill, the high merit of Mr. Terry's presentation will be appreciated.

In substance his argument was that though the word "commerce" originally connected an interchange of commodities from State to State, the Supreme Court had from decade to decade widened the meaning of the word until it now included not merely trade but transportation, the interchange of telegraph messages, the carrying of lottery tickets on the person of a mere traveler, travel itself; in fact, intercourse between the States in the broadest possible sense of that word. It can be stated with some confidence that as to this the committee seemed to agree with Mr. Terry. In other words, he demonstrated to the committee that Congress had power to legislate concerning

the registration of the newest means of intercourse, or intercommunication, between the States.

Mr. Terry also called attention to a line of decisions by the Supreme Court, which held that under the commerce clause of the Constitution the Federal government had power to pass laws which would prevent one State from exacting license fees, tolls, or taxes, either from vessels or from their pilots or masters, when plying navigable waters entirely within a State other than the State where the vessel was enrolled, and called attention to the fact that there was in principle no difference between the natural highways of a State or nation, that is, the waterways and the dirt highways, and also that there was no difference in principle between a vessel navigating such natural highways and a wheeled vehicle using such artificial highways. Asked by Congressman Malby of the committee whether there was not a distinction between vessels engaged in interstate trade and purely pleasure vessels, Mr. Terry called attention to the case of the yacht "Yosemite," in which the Supreme Court held that there was no such distinction and that a vessel operated between ports of different States and purely a pleasure yacht, was properly subject to the law preventing exactions by States other than that of its enrollment, and that this statute rested solely on the commerce clause of the Constitution.

While the chairman of the committee and several of its members repeatedly asked questions which indicated that they had grave doubts as to the constitutionality of the bill, Mr. Terry's argument made a deep impression and entirely convinced several of the committee. It is not likely that final action will be taken on the bill for some weeks, owing to other matters pressing on the attention of the Judiciary Committee, but it is confidently expected by Mr. Terry and his associates that such action will ultimately be favorable to the bill.

Interviews with members of Congress not on the Judiciary Committee led to the conclusion that should the bill be favorably considered by such committee the bill will pass without substantial amendment or opposition. It is hoped that members of the American Automobile Association will continue to express their interest in the bill to their representatives at Washington, particularly those on the Judiciary Committee.

### President Hotchkiss Headed a Representative Delegation.

It was a substantial representation that President W. H. Hotchkiss assembled at the Capitol, and they came from a dozen State bodies of the National organization. This president has proven the salvation of the A. A. A., which in the past has been led by men who have not had the time or the enthusiasm to do the big work properly. And right here let it be said that Secretary Elliott has been a conscientious factor in carrying out the plans of the president. The delegation present included the following:

William H. Hotchkiss, president American Automobile Association; Charles Thaddeus Terry, chairman Legislative Board, New York; Frederick H. Elliott, secretary American Automobile Association; Russell A. Field, Long Island Automobile Club, Brooklyn; A. G. Batchelder, New York State Automobile Association; C. H. Benedict, Automobile Club of Schenectady; Robert P. Hooper, Automobile Club of Germantown and Philadelphia; Paul C. Wolff, Pennsylvania Motor Federation and Automobile Club of Pittsburg; Jacob D. Rider, Lancaster Automobile Club; G. Douglass Bartlett, Quaker City Motor Club, Philadelphia; W. C. Crosby, New Jersey Automobile and Motor Club and Associated Automobile Clubs of New Jersey; R. A. Green, New Jersey Automobile Trade Association, Newark; J. H. Edwards, Automobile Club of Hudson County, Jersey City; William H. Hunt, Automobile Club of Hudson County; Walter S. Schutz, Connecticut State Automobile Association, Hartford; F. T. Staples, vice-president Connecticut State Automobile Association, Bridgeport; Robert B. Caverly and LeRoy Marks, Automobile Club of Washington, D. C.; Charles J. Forbes, Jr., Cleveland Automobile Club; Dr. A. B. Beyle, Cincinnati Automobile Club; Hon. F. H. Gillette, Automobile Club of Springfield, Mass.; L. R. Speare, Bay State Automobile Association and Massachusetts Automobile



Club, Boston; Osborne I. Yellott, Automobile Club of Maryland; John Bancroft, Delaware Automobile Association, Wilmington; F. E. Chapman, West Virginia State Automobile Association; George Ade, Indiana State Automobile Association; S. Boyer Davis, Automobile Club of Philadelphia and chairman of the legislative committee of the Pennsylvania Motor Federation.

The Professional Chauffeurs' Club of America was also represented by President Sullivan and ex-President Walters, with Xenophon P. Huddy, its counsel. The latter discussed the bill briefly, urging chiefly that it be amended so as to permit the Federal registration of chauffeurs while operating motor vehicles in States other than those of their residence.

President Caverley, Secretary Marks and Director Stoddard comprised the Automobile Club of Washington trio responsible for the entertainment of the visitors, the festivities including a smoker at the club's country home.

Congressman Cocks, who accepted responsibility for the bill

in the House of Representatives, isn't afraid these days to be seen in the company of automobilists. When one remembers the unpopularity which this thoroughly straightforward legislator once enjoyed when, in the early days of the industry he sought, as a member of the New York State Legislature, to obtain a statute which in the light of subsequent events seemed liberal at the time, his present championing of the rights of automobilists is not so remarkable after all. And there were other congressmen who were not afraid to dine with the autoists in the glaring electric light of the New Willard on Wednesday evening. These were Malby, Alexander and Moon. When the work of organization of automobilists has attained greater numerical strength there will be more legislators enough unafraid of their constituents to dine with autoists in public. In fact, it is not a wild prediction to make that if the Federal bill can emerge from the committee it will receive enough votes to become a law.

## PROVISIONS OF THE PROPOSED NEW YORK AUTOMOBILE LAW

THE New York State Automobile Association, through President Quayle, announces that the new bill for the regulation and registration of automobiles in the State of New York conforms as nearly as is possible to the uniform automobile bill as suggested by the American Automobile Association, and which is now being considered by the Legislatures of Ohio and Massachusetts. This is the first step toward establishing uniform legislation. The marked differences between this bill and the present motor vehicle law are as follows:

**First.**—The bill provides for the annual registration of motor vehicles, and for the payment of fees sufficiently large in amount to be equivalent to taxation of those vehicles by the State. It is anticipated that the revenue derived from this taxation will return to the State, for the first year, from \$250,000 to \$300,000, with a substantial increase each year thereafter, as motor vehicles multiply. All of the revenue so obtained shall be paid to the special fund for the maintenance of State highways. The fees to be paid are to be based upon weight, and should vary from \$2.00 for the lightest vehicle to not more than \$15.00 for the 6,000-pound cars.

**Second.**—A positively thorough method of identification of motor vehicles when on the public highways is provided for in the provision that all vehicles shall hereafter carry numbers (front and rear), the said numbers to be changed in color each year, and to be issued and provided by the Secretary of State. Severe penalties are imposed for violations of this provision.

**Third.**—In addition to the usual provisions as to lamps, horns, etc., there is an entirely new provision prohibiting the use of non-skidding tire devices, except when the highway is covered with ice or snow, or in an otherwise dangerous condition.

**Fourth.**—The usual exemption for non-resident owners. The same prohibition against local ordinances affecting automobiles, as is in

the present law, together with a brief definition of permissive speed, which corresponds to that recognized in foreign countries, and very much like the provision of the Connecticut law, which is in operation to-day.

**Fifth.**—To assist local magistrates in enforcing the law as to the second and third offences, provision is made for the transmission of records of convictions, under the law, to the Secretary of State, who, in turn, is obliged to notify all the county clerks of the State of all speed violations. Along the same line there is a new provision requiring the Secretary of State to file with each county clerk a list of registered motor vehicle owners and registered chauffeurs, and to file each 30 days a supplemental list, showing registrations to date, to the end that local authorities may ascertain the identity of persons who violate the law and do injury to others while operating motor vehicles.

**Sixth.**—Beside the local penalties for violations, which are somewhat more severe than those at present in force, it will be possible to annul the certificate of registration of any vehicle that uses a fictitious number, and to suspend, for a period of time, the right of any chauffeur to operate any motor vehicle in case of convictions. In addition there is a provision making it a misdemeanor for any person to tamper with or use a motor vehicle without the consent of its owner. This provision will be much appreciated.

This bill is the result of many conferences between leading members of the legislature and representatives of the New York State Automobile Association, and it is thought to give effect to an understanding between representative interests, whereby the present law shall be brought up to date and made more easily enforceable, and whereby the motor vehicle users of the State acquiesce in the payment of an annual registration fee for the express purpose of maintaining improved highways.

### OHIO LEGISLATORS WANT INCREASED FEES.

COLUMBUS, O., March 16.—Evidently the members of the Ohio legal mill are in favor of grinding more out of the owner of an auto than they have hitherto succeeded in doing, as the Ward bill, which calls for a license fee of \$3 for cars of 12-horsepower or less, \$5 up to 20-horsepower, \$10 up to 50-horsepower and \$15 above that, has already passed the Senate, and is now before the lower house. Dealers' licenses are to cost \$10 for each type of car, and chauffeurs' licenses will cost \$2, while fines of \$25, \$50 and \$100 and 30 days' imprisonment are provided for repeated offenses. These penalties are not alone for speed or registration violations, but also refer to the sections covering equipment, such as lamps, horn, etc., and compliance with rules of the road. The speed limits are 8, 15 and 20 miles an hour, respectively, according to the nature of the district, and reciprocal rights are granted to non-residents registered in their home States. Special penalties of a fine up to \$300 and 60 days' imprisonment are provided for carrying a fictitious number; \$100 and suspension of license for two years for failure by chauffeur to register, and \$200 for unwarranted use of another's car.

### MICHIGAN'S STATE LAW NOT WELL ENFORCED.

DETROIT, MICH., March 17.—Some of those who hailed with loud acclaim the law requiring all owners of automobiles to secure a State license, thus taking the matter out of municipal control, are beginning to wonder whether, after all, the move was as good as at first supposed. Detroit's board of assessors, after struggling with the problem in an endeavor to get owners on the personal tax roll, are convinced the plan is not an unqualified success. Either the addresses of many owners were erroneously given to State officials or little care was exercised in making the entries, for, from the records, it is impossible to locate many owners.

Automobile owners have likewise shown a laxness, neglecting to notify the Secretary of State when they disposed of a car, so that the change could be made. As a result, many are credited with owning from three to five cars, when they have disposed of nearly all of them. Many mixups have already resulted, and further trouble is anticipated when it comes to collecting on the assessments made, owing to the difficulty of determining ownership.

## QUAYLE HEADS NEW YORK ASSOCIATION FOR THIRD TERM

**B**UFFALO, March 13.—Something not entirely unexpected in view of recent developments came out at the meeting of the New York State Automobile Association, held in the rooms of the Automobile Club of Buffalo yesterday. The announcement was made of the secession of the Automobile Club of America from the State Association. This action is the culmination of a series of differences that have existed for some time, with a strong degree of unpleasantness, between the New York club and the State body of the national association.

From what was ascertained locally, the New York club has been chafing under the restraint of the national and State bodies with which it is affiliated. One immediate cause assigned is the bill which the legislative committee of the New York State Automobile Association has drawn up. This bill is a model one in many respects. It provides that automobiles shall be exempt from taxation as personal property, but shall annually contribute a registration fee to the State on the basis of \$2 for the first 1,000-pound weight, and 25 cents a hundred for each additional hundred pounds. This measure would bring about \$350,000 in revenue to the State each year.

There is a story current here that A. R. Shattuck, one of the governors of the A. C. A., entertained some of the Albany legislators at the Fort Orange Club in Albany, and told them that the proposed registration in the A. A. A. bill was too cheap for an automobile, and "his organization," the A. C. A., would stand for a yearly tax of from \$4 to \$40, according to the weight of the car. The Albany legislators routed up the legislative committee of the State association and demanded to know what was meant by proposing a tax of from \$2 to \$4, when "those

rich fellows in New York were willing to pay as high as \$40 apiece." It was then the work of the State association to show who was representing the automobilists of the State, the 35 clubs affiliated with the A. A. A., and extending from Yonkers to Buffalo, or the inside ring in the A. C. A. of New York City.

President O. A. Quayle, of Albany, maintained that Shattuck and the several governors of the A. C. A., who always attend meetings, never represented that organization. However, Shattuck got busy, and kept at it until he got the resignation of the A. C. A. offered. When the resignation was presented, a resolution regretting the action of the A. C. A. was adopted, and

the paper laid on the table. President Quayle made the declaration that before any law is enacted taxing an automobile any \$40 a year, it will have to pass over his dead body. He asserts that he will resign before he will stand for anything like that. The attitude of President Quayle was endorsed by President F. B. Hower, of the local club.

Officers of the State organization elected yesterday were: Oliver A. Quayle, re-elected for the third time as president; Charles Jerome Edwards, of the Long Island Automobile Club of Brooklyn, vice-president; C. D. Hakes, Albany, secretary, and N. M. Pierce, Buffalo,

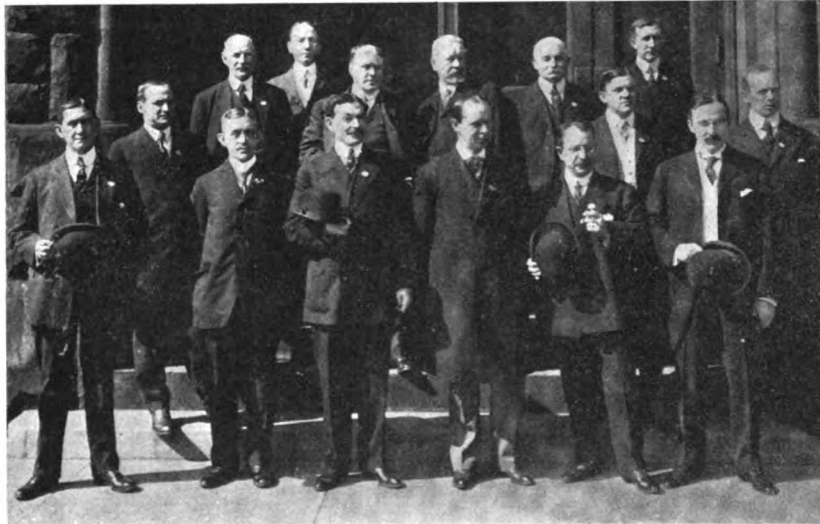

Officers and Directors New York State A. A. at Buffalo.

The group includes President Oliver A. Quayle, Albany; Secretary Chauncey D. Hakes, Albany; Frank B. Hower, H. A. Meldrum, Dal H. Lewis, Norman M. Pierce, and Mr. Weaver, Buffalo; M. L. Ruder, Albany; J. W. Snowden, Peekskill; H. H. Franklin, Syracuse; D. A. Burtiss, Schenectady; S. C. Tallman, Auburn; George Forbes, Olean; L. H. Babcock, Norwich; J. B. McMurrick, Oswego.

treasurer, the accompanying photograph showing the officers.

The meeting approved the bill providing for highway improvement; also the State Motor Vehicle measure, drafted by the State Automobile Association. At the conclusion of the meeting the members were entertained by the members of the local club at a dinner at the Buffalo Club. Later, all attended the automobile show, held here this week. Further developments in the situation may be forthcoming at any time.

## PRES. QUAYLE ISSUES STATEMENT ON A. C. A. MATTER

**P**RESIDENT OLIVER A. QUAYLE, of the New York State Automobile Association, has issued the following statement in relation to the differences between that body and the Automobile Club of America, relative to the matter of dues:

The constitution of the New York State Automobile Association provides, in the matter of dues, that they shall be paid bi-annually, at the rate of \$1.00 per club member, except that when a club shall have a membership in excess of 500 members, then no dues shall be paid upon such excess membership. The total club membership of the State Association at this time is approximately 6,000 members. Of this number 737 members of the Automobile Club of America have not paid dues, the Automobile Club of America paying no dues upon its membership in excess of 500. Seven hundred and twenty members of the Automobile Club of Buffalo have paid no dues, the Automobile Club of Buffalo paying no dues upon its membership in excess of 500.

The Automobile Club of Buffalo, recognizing the apparent injustice of such a provision, offered an amendment to the constitution, which would require all clubs to pay the same dues. As the number of clubs in the State Association is increasing, and as the membership in these clubs is likewise rapidly increasing, it has been necessary for me to explain upon many occasions why a club of 400 members were required to pay \$400 a year, when a club of 1,200 members were required to pay but \$500 per year.

This proposed amendment to the State Constitution is not for the purpose of increasing revenue. The State Association has no need for funds at this time, its income being entirely sufficient. It is merely intended to make more equitable the present provisions of the Constitution relative to dues, by requiring its 1,500 non-paying members (737 of which are represented by the non-paying membership of the Automobile Club of America and 720 by the non-paying membership of the Automobile Club of Buffalo) to pay dues, and reducing the dues from \$1.00 to 75 cents for all clubs.

The income of 75 cents per member on the association's full membership would produce a revenue equal to the dues of \$1.00 per member, on its present dues paying membership, leaving the State Association's annual income practically identical, and yet reduce the dues of club members 25 per cent.

The State Association, while mindful of the influence and prestige of its largest clubs, must give due regard to the small ones.

The club dues in every automobile club in the State of New York at this time (with two exceptions) is \$5.00 per year per member. Clubs are now paying the State Association \$1.00 per year per member, or one-fifth of their revenue. If, therefore, their dues in

the State Association could be reduced to 75 cents, they would be relieved of a considerable burden.

Therefore, I cannot reconcile myself in the belief that the resignation of the A. C. A. is precipitated over a matter of \$300 or \$400. Again, my personal acquaintance with many of the members of the A. C. A. is such that I know that an item of \$300 or \$400 could not occasion a difference of opinion. On the other hand, I am inclined to think that the real differences are over a matter of legislation, and I may desire to make a further statement in connection with the legislative situation after the convening of the legislature on Monday next.

## HOTCHKISS SAYS NO SINGLE CLUB CAN LORD IT OVER OTHERS

RELATIVE to the resignation of the Automobile Club of America from the New York State Automobile Association, President William H. Hotchkiss, who was in New York last week, when asked his views, said:

"While the difference between New York's local club and the State Association proper, which is a body of forty clubs, including one at Buffalo as large as the local club here, have been brought to a head by the contemplated action of the State body, requiring the New York club to pay dues on a per capita basis of its full membership, the breach dates well back, and was opened by a conflict over matters of State policy in legislation.

"It is, perhaps, proper for me, as president of the American Automobile Association, to say that I do not regret the resignation, but welcome it. It is high time that motorists understand whether a mere name adopted in the infancy of the motor

vehicle in this country, and which has since become a misnomer, entitles any local club in any city, no matter how great, to lord it over hundreds of other clubs in other parts of the country. Indeed, the time has now come to determine whether the American Automobile Association represents those motorists or whether they are to be represented by a small clique of gentlemen who manage a local social club. I, therefore, hail the issue, and have no doubt of the result.

"The American Automobile Association is now composed of twenty-one State organizations, with an application in from the twenty-second State, and is represented by clubs in almost every State where motoring is general. It has absolute control of the sport in this country, and of all touring and technical contests, to say nothing of its premiership in matters of legislation, both national and State."

### W. K. VANDERLILT, JR., UPHOLDS A. A. A.

Before leaving for his home in Buffalo, after returning from the legislative hearing at Washington, President William H. Hotchkiss, of the American Automobile Association, received assurances from William K. Vanderbilt, Jr., that he had no intention of withdrawing as a director of the Three A's, and that he would continue loyal to its interests, despite the withdrawal of the Automobile Club of America from the State Association, which carries with it a resignation from the A. A. A. Discussion of the situation has brought out the fact prominently that many of the members of the Automobile Club of America are not entirely in accord with the recent action of the club's governing board, and from his statement, Mr. Vanderbilt would appear to be one of these.

### MARYLAND GOOD ROADS BILL TO PASS.

ANNAPOLIS, Md., March 16.—The good roads bill, which was recently introduced in the Senate by Senator Benson, and which, when passed, will give Maryland the best State roads in the country, has been approved by Governor Crothers, and will doubtlessly be passed this week. An amendment was offered to the bill by Senator Linthicum, which provides that all turnpikes near the city where toll-gates are located, and which are controlled by corporations, be condemned under the provisions of the law. Among those who were instrumental in having the bill brought before the legislature were the automobile clubs of Baltimore and Washington.

The idea of the Governor is to appoint a paid commission of six, three to be appointed by him and three to be taken from the Geological Survey. The Governor said that the work would be done under State control and under State supervision. The Governor, who is a member of the Survey, will be a member of the commission, and the other two will be Dr. William Bullock Clark and Dr. Ira B. Remsen, president of Johns Hopkins University. The three members are to be paid salaries, while the survey members on the commission will mean that the survey will have something to do with the construction of the roads, provided the paid members agree.

### TIRE CHAINS BARRED IN FAIRMOUNT PARK.

PHILADELPHIA, March 16.—At its meeting last Thursday, the Fairmount Park Commission passed a resolution forbidding the use of tire chains on automobiles within the park limits, on the ground that the roads are liable to damage thereby. An exception was made of Belmont avenue, which will permit of Main Line residents and through-route tourists reaching Lancaster pike without removing their chains. To compensate in part for this prohibition, it was decided to substitute asphalt for the rough Belgian blocks on the north side of Girard and Parkside avenues, from the west end of Girard avenue bridge to the Belmont avenue entrance to the park. This will give access to Belmont avenue from the north for cars with chains on.

In this connection, the Quaker City Motor Club has officially protested against the awful conditions around the City Hall, where the Rapid Transit Company is about completing the subway loop. Between mud and Belgian blocks and patchwork asphalt, the going is something fearful, especially in wet weather. Another evil was called to the attention of the city officials—the stretch of Belgian blocks on the "Hump" on Broad street over the Reading Railway tracks at Huntingdon street station. The automobilists ask for an asphalt strip in the center or narrower ones at each side, to do away with the jarring and shaking their cars are subjected to while covering that short stretch.

### INDIANA ACTION AGAINST RECEIVER POPE.

INDIANAPOLIS, March 14.—A petition was filed in the United States Court here to-day, asking that Albert L. Pope be removed as receiver for the Pope Motor Car Company. The petition was filed by the Northern National Bank, the National Bank of Commerce and the Bostwick-Braun Company, all of Toledo, and the Capital National Bank of this city. It is stated in the petition that the Pope Manufacturing Company is making a claim of \$800,000 against the Pope Motor Car Company. The petitioners state that they are creditors of the Pope Motor Car Company to the extent of \$240,000, and that Mr. Pope is negotiating to sell the Indianapolis plant for \$400,000, one-fourth or less in cash, and the balance on long time.

## EARLY SPRING DOINGS OF THE AUTO CLUBS

### A. C. C. ON THE NECESSITY OF ORGANIZATION.

CINCINNATI, March 16.—In the bulletin of the Automobile Club of Cincinnati, the advantages of membership in it are set forth in no unmistakable manner. Among other things said in endeavoring to persuade Cincinnati autoists to join the club are the following:

"There are two things which most deeply concern every user of the motor car. There are good roads and rational legislation. As individuals, there is but very little that any of us can do in securing either. Collectively, we can exert a powerful influence for both. It has been truly said that in this country the good roads question was never spelled with capital letters until the automobilists took hold of it. The automobile clubs throughout the United States are at present exerting a powerful influence in the shape of legislation for highway improvement. Good road officials all over the country recognize in the automobile clubs their best allies in their interests to improve the roads. Sam Houston, State Highway Commissioner of Ohio, came down from Columbus recently, to tell the members of the Cincinnati Club what the State of Ohio is doing now for good roads, and to ask the support and influence of the club in his effort to secure legislation by which the State will assume 50 per cent. of the cost of road construction and maintenance all over the State. At the club dinner held that evening, Mr. Houston stated that he found that the members of the automobile clubs were the men on whom he could most rely for support in his measure.

"The necessity of organization and unity of action to secure uniform and rational legislation is only too apparent when we consider that at present not only has each State a different law, but that also in many States one finds that each town has its own peculiar law regulating the use of the motor car, with resulting confusion to the automobile tourist. Automobile legislation will never be solved to the satisfaction of the motorist until, by unity of action, we secure uniform laws throughout the different States.

"Membership in the Automobile Club of Cincinnati includes membership in the American Automobile Association and the Ohio State Automobile Association, and the ten dollars paid as dues to the local club also pays the dues of the State and National organizations, and entitles all members of the Cincinnati Club to all the advantages derived from membership in these organizations."

### ALBANY CLUB TO HOLD A FIVE-DAY RUN.

ALBANY, N. Y., March 16.—In accordance with the plan it has followed for the past two years, the Albany Automobile Club will hold a five-day run this summer, beginning June 20. The route will be to Greenfield, Mass., the first day; to Providence, R. I., the second day; New London, Conn., the third day, and to New York the fourth, returning to Albany by way of Waterbury, Conn., on the last day of the trip.

In connection with the prosecution of Justice of the Peace Van Ness, of East Greenbush, a suburb of Albany, for misappropriating funds received as fines, and which is being prosecuted by the club, through its attorneys, Bender & Hinman of Albany, a number of wall placards are being distributed to clubs and garages. These bear a request to all autoists who were fined in that hamlet at any time during 1906 and 1907 to communicate with the law firm mentioned, as by so doing they may promote the cause of justice and the welfare of the autoist.

### A CLUBHOUSE SOUGHT FOR WILKES-BARRE.

WILKES-BARRE, PA., March 9.—Almost as soon as a suitable site or building can be secured, the Wilkes-Barre Automobile Club will possess its own club premises. One of the best propositions now being considered is the old Wilkes-Barre and Eastern railroad station, on West Market street, and adjoining Nesbitt Park. When improvements have been carried out this building would be an excellent one for automobile club purposes. A scheme has also been brought forward by which the automobile club should co-operate with the recently formed Amateur Driving Club in securing joint headquarters large enough to accommodate both organizations, as this would permit of better facilities being procured.

### ACKNOWLEDGES QUAKER CITY M. C.'S OFFER.

PHILADELPHIA, March 16.—Thursday last the Quaker City Motor Club received from the National Government an official reply to its offer to organize an emergency corps of automobilists, to serve in defense of the nation when called upon. The letter from the Assistant Secretary of War follows:

WAR DEPARTMENT.

Washington, March 12, 1908.

H. C. Harbach, Secretary Quaker City Motor Club.

Dear Sir—I have the honor to acknowledge the receipt of your letter of February 22, 1908, addressed to the President of the United States, and inclosing a preamble by your club offering the use of its motors and the services of its members as an auxiliary force to the Federal Government in case of insurrection or foreign invasion. Upon receipt of your letter the President referred it to the War Department for suitable acknowledgment. I beg, therefore, to express the appreciation of the President and of the War Department of your patriotic action in this matter, and to say that, should an emergency of the nature indicated in your preamble arise, the generous offer of your club will be borne in mind.

(Signed),

ROBERT SHAW OLIVER.

Assistant Secretary of War.

### ARKANSANS ORGANIZE—STATE BODY COMING.

LITTLE ROCK, ARK., March 14.—At a meeting of the automobile enthusiasts of this city, held last Monday afternoon at the Real Estate Exchange, the Automobile Club of Little Rock was organized with the following board of officers: President, Moorehead Wright; first vice-president, J. P. Runyan; second vice-president, J. N. Heiskell; secretary, Irving S. Hirsch; treasurer, Perry Stiff. The officers named, together with E. P. Ladd, C. A. Pratt, J. E. Osborne, W. B. Miller and J. A. Van Etten, constitute the board of directors. The club will be incorporated under the by-laws of the American Automobile Association, and a State body will be formed. Capt. C. A. Pratt has been named as State director, to represent the local body in the national association. It is planned to organize clubs at Fort Smith and Pine Bluff, and perfect the State organization.

### FAIR QUAKERITES TO ENDOW A HOSPITAL BED.

PHILADELPHIA, March 9.—For an exceedingly young organization, the Quaker City Ladies' Motor Club is certainly an exceedingly spunky one. With a rather limited membership list, it has set about to endow a bed in the Garretson Hospital for those injured in autoing accidents. They are gathering in the funds quite rapidly, but, to expedite matters, decided at last week's meeting to call on their brothers, husbands and friends in the Quaker City Motor Club to lend a helping hand. The work is now booming, and the "automobile bed" will be a reality within a few weeks.

### DELAWARE ASSOCIATION BEGINS ACTIVE WORK.

WILMINGTON, DEL., March 16.—At a meeting held here during the past week the Delaware Automobile Association decided to undertake the work of marking the roads, and will have finger boards giving directions and distances at the intersections of the principal roads throughout the State. This is something in which Delaware has been lamentably lacking. The association has just issued its 1908 year book.

### FIRST BANQUET OF YALE AUTOMOBILE CLUB.

NEW HAVEN, CONN., March 16.—The first annual banquet of the Yale Automobile Club will be held at the University Club next Wednesday evening, and will mark the opening of the auto season for 1908. Hill-climbing contests and race meets at the Branford Driving Park will follow. The Yale club is one of the largest of its kind in the East.



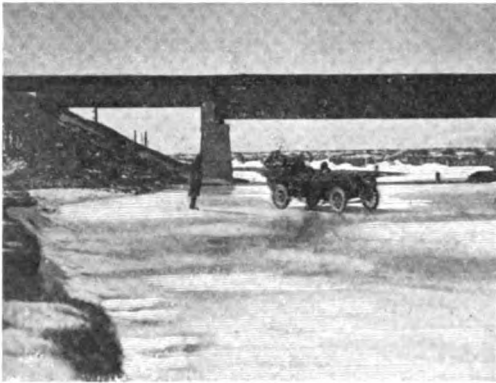

The Thomas Crossing Medicine Bow River, Wyo.



Buffalo Bill's Daughter Greet's Thomas at Hershey, Neb.



Through Snowdrift near Rock River, Wyo.

**THOMAS CAR CROSSES NEVADA LINE.**

COBRE, Nev., March 17.—The Thomas New York-Paris car reached this place at 8:48 P. M. to-day, making 182 miles from Ogden, Utah. Sandstorms were encountered, which, owing to unsuitable goggles, made driving very difficult.

Upon arriving at Cheyenne, Wyo., Montague Roberts, the Thomas driver who has made such a successful fight against odds that have kept his foreign competitors far to the rear, relinquished command of the car in order to return to New York, as he is scheduled to drive in the Briarcliff trophy race and other events of the season. E. Linn Mathewson took charge, and drove the car as far as Ogden, Utah, which was reached last Tuesday, where he turned the Thomas over to Harold Brinker, of Denver, who will take it through to San Francisco, Captain Hansen, late of the De Dion team, having signed on to cover the Alaskan and Siberian portions of the route. The Thomas arrived at Bitter Creek, Wyo., on Wednesday of last week, having covered 2,300 miles, its closest competitor, the Zust, then being 422 miles in the rear. The river is 15 feet deep at Bitter Creek, the wagon bridge was down, and it was too risky to try the railroad bridge, so, after struggling down the steep bank, the car was run across on the ice, which was eight inches thick. Granger, Wyo., was reached Thursday night, having covered ninety miles, in spite of the fact that the Thomas crew and car have frequently been called upon to come to the rescue of the pilot car. At Thayer Junction, it was necessary to ford Bitter Creek, as the ice was not strong enough, but the Thomas plowed through two feet of mud, water and floating cakes of ice without any trouble.

At 10:45 P. M. Friday, the Thomas rolled into Evanston, Wyo., making its total mileage 2,460. Some forty-odd miles of this were covered over the Union Pacific right of way, including a run through the tunnel at Aspen Ridge, saving many days' work of snow shoveling, as the drifts in the mountains, which are 9,000 feet high, reached ten feet in depth. Saturday's total was disappointing, ten hours' fighting through snow and mud only advancing the car 20 miles, but no stop was made, and after 25 hours' continuous running, the Thomas arrived at Ogden at 9:30 A. M.

At that time the Zust was at Rawlins, Wyo., the De Dion at Omaha, Neb., the Protos at Ames, Ia., and the Motobloc at Tama. This gave the Thomas a clear lead of 310 miles, but before leaving Ogden at four the next day, the Zust had cut this down to 226 miles, and the others had advanced from 60 to 98 miles, the Protos making the best showing. The mileage for the last seven days is as follows:

Car.	Country.	Day. 29.	Day. 30.	Day. 31.	Day. 32.	Day. 33.	Day. 34.	Day. 35.
Thomas	(America)	2,300	2,390	2,460	2,480	2,536	2,536	2,718
Zust	(Italy)	1,878	2,052	2,109	2,186	2,226	2,310	2,360
De Dion	(France)	1,386	1,516	1,524	1,524	1,536	1,582	1,690
Protos	(Germany)	1,262	1,332	1,369	1,369	1,369	1,467	1,536
Motobloc	(France)	1,101	1,181	1,263	1,262	1,313	1,394	1,439

**MOTORING A LA CHAFFRAY.**

Saint Chaffray announced that he would ship his car by freight to Seattle on March 5, to catch the steamer to Valdez. He stated that the first car to arrive in Paris would be the winner. Roberts says he does not propose to make a freight contest of the New York-to-Paris race.—News item.

"Arouse, brave comrade, Autran!  
There's work to do, allons!  
Make haste with boards and hammer  
To crate the De Dion.  
A bas! the frightful highways  
That wrought us much dismay!  
We tour henceforth by freight car,"  
Quoth Bourcier Saint Chaffray.

"Before us rise high mountains  
Our onward way to bar,  
Those Rockies and Sierras  
Reject our touring car.  
But courage, my brave Autran!  
Behold, a better way!  
We'll scale them on a flat car,"  
Says Bourcier Saint Chaffray.

"The wilds of dire Alaska  
Shall not us terrorize;  
Though trails comprise the highways  
And snowdrifts touch the skies.  
A railroad goes from Valdez;  
Will it not be au fait  
To motor in a box car?"  
Asks Bourcier Saint Chaffray.

"Those drear Siberian tundras  
Where Desolation reigns  
Shall daunt not Bourcier's courage  
But yield to Bourcier's brains.  
That Trans-Siberian Railroad  
From snow is clear by May—  
We'll go by freight to Moscow,"  
Cries Bourcier Saint Chaffray.

"Then hasten, my brave Autran!  
Pack up the broken springs,  
Collect the drive-shaft fragments  
With other injured things.  
Discard the pick and shovel,  
They now are much passe.  
The fastest freight for Paris  
Gets Bourcier Saint Chaffray."

—T. J. Sullivan in "Buffalo Evening News."



When the Gearless Returned Home from Its Piloting Trip.

Arrival of the Gearless Greyhound at Rochester from Chicago after having acted as pilot car for the New York-Paris contestants. Distance covered, over 1,800 miles.

**NEXT WEEK INDIANAPOLIS HOLDS FORTH.**

INDIANAPOLIS, March 17.—Practically all arrangements have been completed for the second annual automobile show, which begins next Monday and will continue throughout the week.

Because there is no building large enough for a combined show, each dealer will exhibit in his own garage, from where special demonstrations will be made. Factories will also keep open house, and tire and accessory manufacturers are arranging for special demonstrations.

There will be a number of public events during the week, in which dealers and drivers from all parts of the State will unite. On the opening day there will be a parade, in which at least 200 automobiles will participate. It will be headed by the police automobiles and a five-ton truck carrying a band. Each automobile appearing will bear a card of uniform size, giving the name of the car, price and the local agent.

On Tuesday morning, at 11 o'clock, the hill-climbing contest will be held at Michigan Hill, northwest of the city. There are about fifty entries, and a special contest has been arranged for trucks and delivery wagons.

The obstacle race, on Friday afternoon, will be held on the Capitol Avenue boulevard, and about forty entries have been made. The closing feature will be a love feast and smoker at a local hotel for the dealers.



"Sealed-Bonnet" Mora Wheel Deep In the Snow.

**MORA CAR'S STRENUOUS WINTER TRIP.**

Not content with having some 8,000 miles under sealed-bonnet conditions last season to its credit, the Mora car, which successfully took part in the first sealed-bonnet contest run by the Automobile Club of America, and every one since then, was started from Rochester, together with the New York-Paris contestants. The Mora met with several accidents last summer, such as the smashing of a wheel, breaking of the steering gear connections and part of the radiator, but repairs to these parts were carried out without interfering with the original seals placed on the bonnet by the officials of the Chicago Motor Club last June. The Mora left Rochester at noon on February 16, in company with the Züst, but as the latter went into a shop for repairs, the Mora kept on to Buffalo, where it joined the Thomas and De Dion the same afternoon.

The story of its trip westward from Buffalo is that of a continuous struggle against almost overwhelmingly adverse conditions for every step of the way, during the course of which the Mora crew and car used their efforts in helping out first one and then another of the contestants in the New York to Paris run. On one day the total distance covered was seven miles. Chicago was finally reached, after many mishaps and hardships, and the day following the arrival of the Mora, the technical committee of the Chicago Motor Club, who sealed the bonnet last June, inspected the seals and certified that they had not been disturbed since originally placed on the car on June 19, 1907, so that the Mora was enabled to add 650 miles to its world's record of 8,000 miles under sealed bonnet conditions. Some idea of what the going was like for a large part of the way may be gained from the photograph showing the car almost out of sight in the snow.



Governor Hughes Entering White Steamer, Boston.

Last week New York's Governor visited the Hub, and did all his traveling in the White car, placed at his disposal by the local reception committee.

**ELMORE SHOWS STRIKING ECONOMY FIGURES.**

With a view to demonstrating beyond the shadow of a doubt the economy of the Elmore car, the makers selected 16 Elmore owners at random from those in Detroit, Mich., for the purpose of ascertaining exactly what their expenses had been for repairs. These 16 owners had traveled a total of 132,650 miles, and in covering that tremendous distance had expended all told, for repairs, the sum of \$26.95. The following gives the distances covered and the repair cost in each instance. All the owners are residents of Detroit:

Miles.	Years In Use.	Repairs.	Owners.
12,000.....	1	\$1.05	Dr. E. B. Smith
6,500.....	1	.05	Dr. F. S. Kiskadden
4,800.....	1	.50	Chas. W. Munz
5,000.....	1	.10	Dr. F. W. Young
8,500.....	2	.75	John K. Smith
7,200.....	1	1.35	Miss Mabel Wright
7,000.....	1	1.60	W. H. Allen
4,750.....	1	1.10	W. F. Barr
8,000.....	1	1.00	M. Caley
8,200.....	1	.50	John Trost
10,000.....	2	5.75	F. Peckencher
6,200.....	1	.25	Mat. Heldrath
18,000.....	2	5.90	J. J. Miller
3,500.....	1	.50	Perry Hibbard
14,000.....	3	4.75	Thos. H. Van Loch



The Mora Arriving at the Chicago Automobile Club.

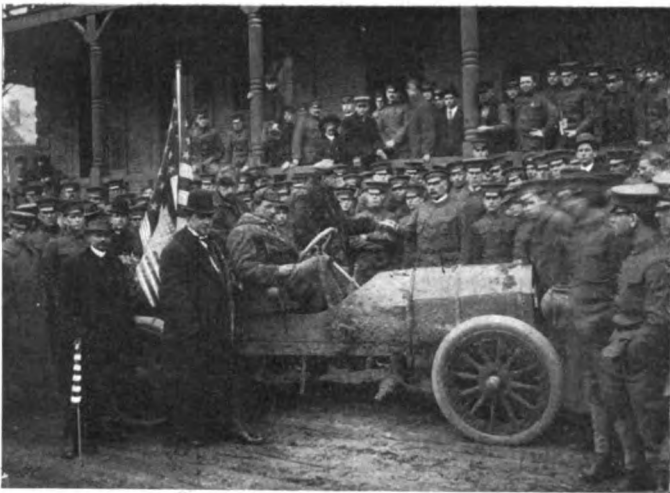

Studebaker Delivering Message to Col. Loughborough.

### SUCCESSFUL TRIP OF THE STUDEBAKER.

For the last few hundred miles of its trip, the Studebaker car and its crew, which were sent on a war mission, bearing dispatches from General Grant at Governor's Island, New York City, to Colonel Loughborough at Fort Leavenworth, Kan., received one continuous ovation. Farmers had notice of their coming well in advance, and lined the roads to see them pass, flags being displayed at various places. At Atchison they were accorded an elaborate reception, including a banquet. This point was reached at four o'clock in the afternoon, and the drivers were compelled to halt for a few hours. Fort Leavenworth was reached before noon the next morning, and the dispatches formally delivered to the commandant of the post, as shown by the accompanying photograph. Just to show that the Studebaker was as good as ever, Jack Huger drove it to Kansas City, through 26 miles of mud, in an hour and a half, on the following day.

### FIRE FIGHTER FOR PENNSYLVANIA BRIGADE.

Massachusetts and Minnesota have united in the production of the automobile fire engine recently handed over to the Radnor Fire Company, of Wayne, Pa. A stock model D-6 chassis, manufactured by the Knox Automobile Company of Springfield, Mass., furnishes the power necessary to reach the scene of operations in the shortest possible space of time. The power plant is the standard two-cylinder horizontal opposed air-cooled motor, capable of driving the fire engine at a speed of 15 miles an hour.

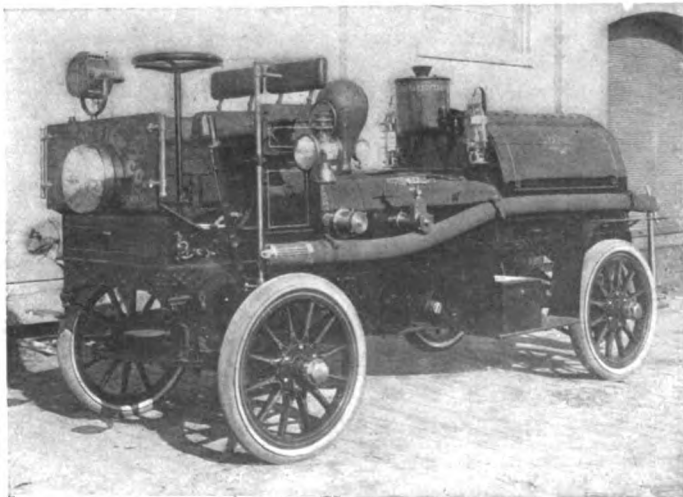

The Knox-Waterhouse Automobile Fire Engine.

On this chassis the Waterhouse Engine Works Company, of St. Paul, Minn., has mounted a water-cooled four-cylinder vertical 45-50-horsepower motor, directly connected to one of their rotary pumps having a capacity of 360 gallons per minute. The weight of the entire outfit, including suction hose, play pipes, etc., is 6,200 pounds.

### AMERICAN TAXIMETERS NOW ON THE MARKET.

The American-built taximeter has now come forth as a serious rival of the foreign instruments which for a few months were the only distance and fare recorders in use in the United States. Manufacturing under a patent owned by the Taximeter and Cab Company of America, the Westchester Appliance Company is now producing the recording machine illustrated herewith. The selling rights are controlled by the Ajax-Grieb Rubber Company, with New York headquarters at Fifty-seventh street and Broadway.

According to a statement by Horace DeLisser, president of the company, a first order for 2,600 of these taximeters has been received, each instrument working at a tariff of 50 cents a mile. A further order is said to be pending for a series of instruments working at the New York rate of 30 cents for the first half mile, 10 cents for each additional quarter, and 10

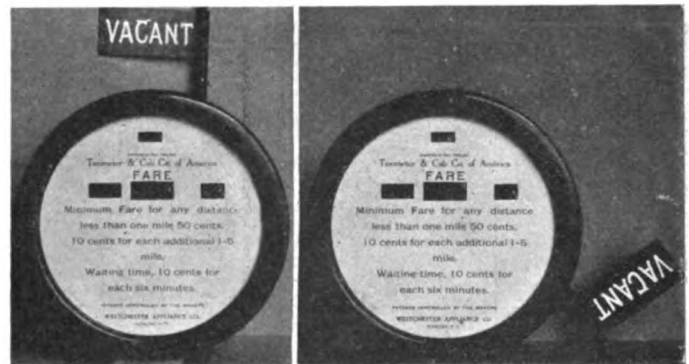

Views of the New Ajax-Grieb Taximeter, "Vacant" and "Engaged."

cents for every six minutes of waiting. The Ajax-Grieb taximeter records the number of trips, the total cash for the day, total number of miles covered, and each individual fare.

### TRADE LITERATURE THAT HAS COME TO HAND.

**Maxwell-Briscoe Company, Tarrytown, N. Y.**—"Faith and Its Realization, the Story of an Industrial Accomplishment," is a narrative of more than usual interest, dealing with the history and beginnings of the Maxwell-Briscoe factory at New Castle, Ind. There are some excellent illustrations of scenes at the inauguration of the factory, when Vice-President Fairbanks, himself a native of the State of Indiana, laid the corner stone and made an address upon the rapid development of the national industries and the solution of national problems.

**New York Gear Works, Brooklyn.**—Without undue verbosity, but sufficiently in detail to suit the motor boat enthusiast, and illustrated sufficiently to make it readily comprehensible, this company presents its Ball improved reverse gear for marine work. Included are tables of dimensions giving weights and prices of the different gears, as well as other data required for the selection of a gear to suit the requirements of certain sizes and types of engines and boats.

**York Motor Car Company, York, Pa.**—A study in brown and gold has been adopted as the cover of the new catalogue of the Pullman car, manufactured by the York Motor Car Company. The catalogue stands high as a trade publication, giving just the information desired by automobilists and prospective buyers and being artistically produced.

## BRIEF ITEMS OF NEWS AND TRADE MISCELLANY

On March 12, at Milwaukee, S. W. Hartley, designer of the Cleveland car, driving "Old Scout," the first of the 1908 Cleveland cars, came in victorious in the three-day endurance run. As it was the first of its kind, this Cleveland has been used as a testing car ever since its completion and has covered more than 30,000 miles since last August.

According to figures given by the Quaker City Automobile Company, of Philadelphia, the average cost of repairing Franklin cars during a period of fifteen months has been \$7.50. The company guaranteed to repair all 1907 model Franklins free of charge from October 1, 1906, to January 1, 1908, and the low figure in question represents the cost of living up to their guarantee.

Much has been said and far more written concerning the care of pneumatic tires, but it is a subject that cannot be overdone, so that the booklet just issued by the Goodyear Tire & Rubber Company, of Akron, O., entitled "The Care of an Auto Tire," is timely. That it is likewise to the point goes without saying, as it contains the experience of skilled tire makers and users condensed for practical use.

The Logan Construction Company, of Chillicothe, O., has been shipping a large number of trucks recently to representative houses, among them a Model T ton truck to the Allen Carpet Cleaning and Rug Weaving Company, Buffalo, and another of the same model to Peter Peterson, furniture mover, Milwaukee, Wis. Inquiries for commercial cars are reported as plentiful in the Central and Middle West.

A. P. Henley, traveling representative of the H. H. Franklin Company, who has just returned from an extended trip to the Pacific Coast, says that farmers are buying automobiles. Crops were good last year, prices were high and the farmers have money. The owners of the big ranches find there is nothing to equal the automobile for covering the ground effectively and they are buying machines that are built to stand the racket.

"The Fairweather Club" is the title of a recently formed "eating" organization mainly composed of prominent agents and branch managers of New York's "automobile row." It will give its second dinner in honor of Colonel K. C. Pardee, the Maxwell distributor, at the Hotel Cumberland, Fifty-fourth street and Broadway, April 1. Henry M. Duncan, of the J. B. Brewster Co., will preside, and among the speakers will be Messrs. Cresswell, McLaughlin, John S. Crosby and Colonel Pardee.

The H. H. Franklin Company, Syracuse, N. Y., last week awarded as a prize a fine gold watch to Irving R. Gardiner, superintendent of the auto department of C. H. Childs & Company, Utica, N. Y. The contest was open to all Franklin dealers, the prize being offered for the best ten reasons why a buyer should select the Franklin. Mr. Gardiner's reasons were as follows: "Durability, beauty, elasticity, reliability, air-cooling, accessibility, economy, lightness, high-power and pre-eminence, a short statement being given under each one of these heads.

The businesses operated by the United States Automobile Company, on Plym-

outh avenue, and Fred Mabbett, on Main street, Rochester, N. Y., have been consolidated under the name of the former, and Mr. Mabbett will be general manager. The company's capital stock has been increased from \$200,000 to \$400,000, and the officers are: President, Harry S. Woodworth; vice-president, J. Foster Warner; secretary-treasurer, Charles F. Garfield. The company's establishment on Plymouth avenue is the largest of its kind in New York State outside of the metropolis.

W. E. Flanders, former general factory manager for the Ford Motor Company, and Thomas Walburn, former superintendent of the same concern, have recently become associated with the Wayne Automobile Company, Detroit, Mich., as stockholders. A reorganization of the latter company, has been effected, B. F. Everett still remaining at its head, and with Messrs. Flanders & Walburn, having the management of the concern. Mr. Everett is still president and sales manager, while Mr. Flanders will act as general manager. C. L. Palms, Dr. J. B. Book and William Kelly, who were heavily interested in the old company, remain as stockholders. It is proposed to manufacture on a larger scale than hitherto.

Harry G. Smith, of the Cleveland branch of the Diamond Rubber Company, who had charge of the Diamond supply car in the A. A. A. tour last summer, is captain of the Diamond tire camp on the course at Savannah for the races this week. Twelve of the seventeen cars entered are equipped with Diamond tires, and all but two also use the Diamond demountable rim. The rules require that the driver of the car or his mechanic must make any necessary tire changes, and there will be little for the Diamond crew to do excepting to supply such equipment as may be found necessary. The machines using the Diamond product include the Appersons, Stearns, Thomas Detroits, Thomas Flyer, Lozier, Pennsylvania and American.

### NEW AGENCIES ESTABLISHED.

Logan commercial cars and the semi-racer runabout will be represented in Rochester, N. Y., by A. Vernon Hart, one of the best known dealers in that city.

Among the new agencies recently established by the Franklin Company to handle the Franklin air-cooled cars during the coming season are the Fruit-Oil Company, Sharon, O.; E. T. Byram, Galesburg, Ill.; Colonial Motor Car Company, Springfield, Mo.; Salina Automobile Company, Salina, Kan.; Montana Lumber Company, Lewiston, Mont., and E. R. Nelson, Ishpeming, Mich.

### RECENT TRADE REMOVALS.

The Philadelphia G & J Tire agency, of which Sanders Levy is treasurer and F. Berrodin, manager, has moved into new and much larger quarters at 713-715 Broad street. A feature of the new establishment is one of the largest and most completely equipped tire repair shops that the Quaker City can boast of.

During the past week the Philadelphia branch of the Ford Motor Company moved

into its new three-story building at 250-254 North Broad street. The building is practically fireproof and affords no less than 40,070 square feet of floor space, so that the new home of the Ford can hold its own even with the most palatial establishments of the Quaker City's "gasoline row." The first floor is devoted to a salesroom, offices and garage, while the second is given over to a stockroom and the third is occupied by a large repair shop.

### PERSONAL TRADE MENTION.

Harry S. Houpt, president of the Harry S. Houpt Company, New York representatives of the E. R. Thomas Motor Car Company, of Buffalo, has just returned from a sojourn in Colorado and New Mexico, where he has been spending the winter in recuperating. Mr. Houpt has returned very much benefited in health and will immediately assume personal charge of the Thomas selling end of this territory.

E. Le Roy Pelletier, former publicity man of the Ford Motor Company, is back after a seven-weeks' trip abroad, and after taking a look-in at the Boston show, went west to the scene of his former activities to look after publicity business. It is understood that the former Detroit successively closed negotiations for handling the Maxwell business before going abroad, and upon his return from the West will establish himself in New York City. According to Mr. Pelletier, the New York to Paris race, which has always appeared to Americans in a humorous light, is going to be the cause of much sorrowing on the other side. It was confidently expected to prove the overwhelming superiority of the European cars and bolster the falling market for them in this country. Mr. Pelletier spent three years in Alaska and laughs at the idea of trying to drive a car there.

### DEATH OF ROBT. M. PRATT.

Robert M. Pratt, assistant secretary of the Worcester (Mass.) Automobile Club, and widely known throughout Eastern Massachusetts as a newspaper man, died suddenly after a short illness, on Thursday of last week. He was a son of the late Major J. Wheelock Pratt, and was born at Sterling, Mass., forty-six years ago. He is survived by his widow, mother and brother.

### NEW TAXICABS FOR NEW YORK.

Under the title of the Knickerbocker Taximeter Cab Company, a corporation has been organized with \$15,000 capital to operate taxicabs in New York City. The directors are William B. Hurlbut and Sanford J. Wise, of the Garford Motor Car Company of New York, and Stewart H. Elliott, of 1183 Broadway, New York. The parent Garford Company is now completing 100 20-30-horsepower special chassis for this service, and they will be fitted up in a manner much superior to the cabs now in use. They will be of the landaulet type and it is expected that this first lot will be placed on the New York streets by April 15. Later the company will extend its operations to Boston, Baltimore and Philadelphia. Further details of its plans and a technical description of the cars to be used will be given later.



**INDEX  
TO ADVERTISERS**

Abrams-Mason Co. .... 87	Corbin Motor Vehicle Corp. .... 83	Jackson Automobile Co. .... 68	Picrome Hide Co. .... 65
Acetylene Gas Illuminating Co. 71	Corcoran Lamp Co. .... 74	Jamesville Mfg. Co. .... 65	Pierce Engine Co. .... 69
Acme Motor Car Co. .... 68	Cornish-Friedburg Motor Car. 68	Jeffery & Co., Thos. B. .... 111	Pioneer Brass Works. .... 65
Adams Co. .... 68	Correspondence School of Motor 79	Jenckel Motor Mfg. Co. .... 79	Pirelli & Co. .... 57
Add-Wear Auto Tire Sleeve Co. 69	Car Practice. .... 57	Johnson Sporting Goods Co., I. 69	Pierce Co., Geo. N. .... Cover
Aerocar Motor Co. .... 68	Cotta, Chas. .... 65	Jones Speedometer .... 71	Portland Garage Co. .... 65
Ajax-Grieb Rubber Co. .... 69	Cowles & Co., C. .... 56	Joyce-Cridland Co. .... 100	Precision Appliance Co. .... 55
Almy Water Tube Boiler Co. .... 56	Crane Puller Co. .... 85	K. W. Ignition Co. .... 70	Premier Motor Mfg. Co. .... 104
Am. Brass & Alum. Works. .... 65	Crown Battery Co. .... 81	Kimball Tire Case Co. .... 78	Prent-O-Lite Co. .... 77
Amer. Motor Car Sales Co. .... 72	Crown Soap Co. .... 79	Kinsler Bennett Co. .... 81	Progressive Mfg. Co. .... 82
American Locomotive Motor 72	Cullman Wheel Co. .... 65	Kissell Motor Car Co. .... 73	Quinby Co., J. M. .... 66
Car Co. .... Cover	De Luxe Motor Car Co. .... 68	Knox Automobile Co. .... 105	Raimes & Co. .... 67
Anderson Forge & Machine Co. 65	Detroit Steering Wheel Co. .... 94	Koontz & Co., J. .... 76	Rainier Co. .... 69
Angier Co. .... 82	Diamond Chain & Mfg. Co. .... 65	Kokomo Electric Co. .... 89	Rauch & Lang Carriage Co. .... 95
Apperson Bros. Automobile Co. 90	Diamond Rubber Co. .... 98	Konigsloew, Otto .... 74	Reeves Pulley Co. .... 77
Appliance Mfg. Co. .... 55	Dietz Co., R. E. .... 75	Lansing-Mahon Press .... 81	Remington Tool & Machine Co. 85
Ashtabula Bow Socket Co. .... 66	Dixon Crucible Co., Joseph. .... 78	Lavalette & Co. .... 83	Remy Electric Co. .... 55
Atlas Motor Car Co. .... 101	Dorris Motor Co. .... 83	Lear Automobile Co., Oscar. .... 68	Republic Rubber Co. .... 78
Auburn Automobile Co. .... 68	Lower Stamping & Mfg. Co. .... 84	Leather Tire Goods Co. .... 69	Rex Wrench Co. .... 61
Audel & Co., Theo. .... 76	Dow Portable Electric Co. .... 57	Limousine Carriage Mfg. Co. .... 66	Richardson Engineering Co. .... 57
Aurora Motor Works. .... 68	Duplex Co. .... 85	Lipman Mfg. Co. .... 74	Robert Instrument Co. .... 56
Austin Automobile Co. .... 76	Earl Motor Car Co. .... 63	Lobe Pump Co. .... 57	Robinson & Son Co. .... 68
Auto Pump Co. .... 56	Echo Horn Co. .... 85	Locke & Co. .... 66	Rock Island Tool Co. .... 82
Auto & Supply Co. .... 56	Eclipse Machine Co. .... 56	Lockwood Bros. .... 89	Ross Gear & Tool Co. .... 65
Autocar Co. .... 95	Edmunds & Jones Mfg. Co. .... 92	Locomobile Co. .... 68	Royal Equipment Co. .... 57-Cover
Automobile Supply Co. .... 56	Eldredge Electric Mfg. Co. .... 67	Logan Construction Co. .... 68	Rushmore Dynamo Works. .... 99
Automobile Trade Directory. .... 72	Elite Mfg. Co. .... 81	London Auto Supply Co. .... 66	Salsbury Wheel Mfg. Co. .... 96
Automobile Utilities Co. .... 56	Ellaworth, J. M. .... 108	Long Mfg. Co. .... 79	Samson Leather Tire Co. .... 99
Auto-Shine Co. .... 56	Elmore Mfg. Co. .... 103	Macbeth-Evans Glass Co. .... 88	Seaboard Florida Limited. .... 98
Auxiliary Spring & Vent-But- 66	Empire Automobile Tire Co. .... 67	Manhattan Storage Co. .... 76	Selden Motor Vehicle Co. .... 75
ton Co. .... 66	Empire Wheel Works. .... 66	Maple City Mfg. Co. .... 76	Shawver Co. .... 71
Avery Portable Lighting Co. .... 79	Excelsior Supply Co. .... 77	Mason, John A. .... 66	Smith Mfg. Co., R. H. .... 57
Baldwin Chain & Mfg. Co. .... 91	Fairmount Engineering Works. 68	Masury & Son, John W. .... 87	Spacke Machine Co., F. W. .... 84
Banker Bros. Co. .... 85	Firestone Tire & Rubber Co. .... 69	Matheson Motor Car Co. .... 101	Spare Motor Wheel of Am. .... 86
Barndt-Johnston Auto Supply 66	Fisk Rubber Co. .... 98	Mayo Radiator Co. .... 69	Speed Changing Pulley Co. .... 82
Co. .... 66	Flentje, Earnest .... 71	McCord & Co. .... 74	Spicer Universal Joint Mfg. Co. 65
Barnett Drop Forging Co. .... 79	Forest City Motor Car Co. .... 95	Merchant & Evans Co. .... 83	Splittdorf, C. F. .... 71
Beaver Mfg. Co. .... 94	Franklin Mfg. Co., H. H. .... 109	Merritt & Co. .... 56	Sprague Umbrella Co. .... 92
Behen-Faught Motor Car Equip- 67	French Mfg. Co. .... 77	Meyers & Sons, C. G. .... 90	Springfield Metal Body Co. .... 66
ment Co. .... 67	Fry, T. C. & W. L. .... 56	Mezger, C. A. .... 76	Stanley, John T. .... 87
Beloit Supply Co. .... 67	G & J Tire Co. .... 76	Michelin Tire Co. .... 61	Standard Automatic Lub. Co. .... 66
Biddle & Smart Co. .... Cover	Garford Motor Car Co. .... 68	Middley Mfg. Co. .... 65	Standard Co. .... 87
Black Mfg. Co. .... 72	Gearless Transmission Co. .... 91	Midland Motor Car Co. .... 60	Standard Oil Co. .... 94
Blasier Mfg. Co., M. E. .... 66	Geisler Bros. .... 53	Miller Bros. .... 78	Standard Welding Co. .... 85
Bliss-Chester Co. .... 56	Gemmer Mfg. Co. .... 81	Miller, Chas. E. .... 83	Steam Carriage Boiler Co. .... 70
Blomstrom Mfg. Co. .... 79	General Accumulator and Bat- 67	Miller & Starr. .... 71	Stearns Co., F. B. .... 69
Boker & Co., H. .... 65	tery Co. .... 55	Mitchell Motor Car Co. .... 68	Stevens-Duryea Co. .... 73
Borbein Auto Co. .... 75	Gibney & Bros., Jas. L. .... 57	Model Automobile Co. .... 103	Stitch-In-Time Vulcanizer Co. 75
Bosch, Robert .... 100	Gilbert Mfg. Co. .... 74	Moline Automobile Co. .... 68	Streator Motor Car Co. .... 104
Boston Auto Gage Co. .... 77	Goldberg Motor Car Devices 68	Moon Motor Car Co. .... 68	Stret Machine Co. .... 70
Bowers Co., F. E. .... 74	Mfg. Co. .... 59	Morgan & Wright. .... 97	Studebaker Automobile Co. .... 62
Bowser & Co., S. F. .... 71	Gray-Hawley Mfg. Co. .... 82	Mosler & Co., A. R. .... 66	Success Auto Buggy Co. .... 69
Boyle & Co., John. .... 97	Gray & Davis. .... Cover	Moss Photo Engraving Co. .... 39	Supplementary Spiral Spring. 88
Bridgeport Vehicle Co. .... 66	Grout Bros. Auto Co. .... 106	Motz Clincher Tire & Rub. Co. 69	Swinehart Clincher Tire Co. .... 81
Brown, Wm. W. .... 56	Ham Mfg. Co., C. T. .... 81	Mutty Co., L. J. .... 34	Syracuse Aluminum & Bronze 65
Brownell Motor Co., F. A. .... 70	Hans Co., Edmund E. .... 86	Motorcar Co. .... 84	Thomas Motor Co., E. R. .... 83
Brush Runabout Co. .... 92	Hardy Co., The R. E. .... 56	Morrison-Ricker Mfg. Co. .... 88	Thompson Sons Co., J. P. .... 71
Buckeye Jack Mfg. Co. .... 82	Harris Oil Co., A. W. .... 56	Motor Car Equipment Co. .... 77	Tray Plate Battery Co. .... 82
Buckeye Mfg. Co. .... 68	Hartford Rubber Works Co. .... 58	Mueller, Albert .... 66	Trebert Gas Engine Co. .... 69
Buffalo Carburetor Co. .... 82	Hartford Suspension Co. .... 70	N. Y. Sporting Goods Co. .... 57	Tucker, C. F. .... 56
Bullard Automatic Wrench Co. 84	Hatcher Auto Parts Co. .... 80	N. Y. & N. J. Lubricant Co. .... 83	Turner Brass Works. .... 65
Bullard Specialty Co. .... 67	Hatfield Motor Vehicle Co. .... 68	National Auto Accessories Co. 56	Two Spot Mfg. Co. .... 84
Buob & Scheu. .... 66	Haws, Geo. A. .... 57	National Motor Vehicle Co. .... 105	Uncas Specialty Co. .... 78
Cadillac Motor Car Co. .... 68	Haynes Automobile Co. .... 91	Neustadt Auto & Supply Co. .... 90	Utility Co. .... 83
Cameron Car Co. .... 64	Healy Leather Tire Co. .... 69	Never-Miss Spark Plug Co. .... 56	Veeder Mfg. Co. .... 89
Canton Drop Forge & Mfg. Co. 65	Heinze Electric Co. .... 61	New Process Rawhide Co. .... 81	Walden Mfg. Co. .... 55
Capitol Auto Co. .... 66	Hercules Auto Specialty Co. .... 86	Nordyke & Marmon Co. .... 68	Warner Instrument Co. .... 102
Case & Hechinger. .... 71	Herz & Co. .... 69	Northway Motor & Mfg. Co. .... 78	Warner Pole & Top Co. .... 66
Champion Co., A. .... 84	Hess-Bright Co. .... 65	Northwestern Storage Battery. 80	Watt-Detroit Carburetor Co. .... 61
Clark, E. S. .... 56	Hicks Speed Indicator Co. .... 79	Nuttall Co., R. D. .... 65	Waukesha Motor Co. .... 84
Cleanola Co. .... 70	Hoffecker Co. .... 73	Ofeldt & Sons. .... 56	Wayne Automobile Co. .... 69
Coes Wrench Co. .... 50	Hoffman, Geo. W. .... 56	Olds Motor Car Co. .... 68	Weed Chain Tire Grip Co. .... 76
Colgan Co., J. W. .... 74	Holley Bros. Co. .... 94	Olds Electric Co. .... 67	Welch Motor Car Co. .... 84
Comptoir d'Innovations pour 67	Holsman Automobile Co. .... 75	Packard Motor Car Co. .... 110	Western Motor Co. .... 81
Automobiles .... 67	Hotel Amsterdam .... 55	Packard Motor Car Co. .... 110	Weston Elec. Instrument Co. .... 90
Conn. Tel. & Elec. Co. .... 86	Hotel Gilsey .... 80	Palmer & Singer Mfg. Co. .... 70	Wheeler & Schebler. .... 102
Connecticut Steel & Wire Co. .... 68	Hotel Pierremont .... 80	Parish & Bingham. .... 65	White Co., The. .... 107
Continental Caoutchouc Co. .... 93	Hotel Piney Woods Inn. .... 80	Parker, Stearns & Co. .... 66	Whitmer & Rung. .... 83
Continental Motor Mfg. Co. .... 70	Hotel Richmond .... 80	Pease & Sons, S. C. .... 68	Whitney Mfg. Co. .... 85
Cook's Sons, Adam. .... 80	Hotel Tuler .... 80	Penn. Auto Motor Co. .... 65	Winton Motor Carriage Co. .... 112
	Howard Motor Works. .... 68	Peugeot Freres .... 79	Witherbee Igniter Co. .... 88
	Hoyt Electrical Ins. Co. .... 70	Perfection Grease Co. .... 67	Wyman & Gordon Co. .... 55
	Huff, E., Jr. .... 63	Perkins-Campbell Co. .... 67	York Motor Car Co. .... 69
	Hydraulic Pressed Steel Co. .... 75	Pfanstiehl Elec. Laboratory. .... 65	
	Imperial Motor Car Co. .... 106		
	Indestructible Steel Wheel Co. 57		

FOR UNMATCHABLE QUALITY BUY

**COES**

STEEL HANDLE MODEL

**WRENCH**

**THE WRENCH for Automobilists**

High-grade quality in every detail of design, material, workmanship and up-to-date improvement. Excellence with extremely reasonable cost.

- NON-BREAKABLE CASTINGS
- NON-STRIPABLE THREADS
- NON-TROUBLESOME PARTS

**QUALITY**

Through and Through.

Look for the name—COES



70 years splendid reputation worthy maintained right up to the present time as the World's Best Wrench Makers. Write for "Wrench Book" free.

**COES WRENCH CO., WORCESTER, MASS.**

# THE AUTOMOBILE



## Savannah Successfully Scores

By  
A. G. Batchelder

SAVANNAH, GA.,  
March 21.—“No. 2  
has passed Sandfly!” sing  
the announcers.

“No. 2 is at the Isle of  
Hope!” is the pronuncia-  
mento that follows. Then, an interval, and, next, from the bellowing  
though musically pitched megaphoners, hurriedly told, is the news that

“No. 2 is turning at Thunderbolt!”

Far up the oil-streaked road there is a blur of red, coming towards  
thousands of excited onlookers who know that the first winning of the  
Savannah Challenge trophy is to be by a foreign-built automobile, yet  
manned by an American crew. 'Tis a pretty sight, in the gorgeous sunlight  
of late afternoon, this marvelously space-devouring perfection of moving  
mechanism, and the beauty and chivalry of the New South, fascinated, enjoy  
the greatest competitive spectacle of this wondrous age to the fullest extent.

Of course, there are hurrahs from the men, parasol and handkerchief  
waving from the women, and vociferous strains from the band. Little Strang  
is a modest and smut-faced hero, not even deigning to wave as he flashes  
past the cheering multitude in the car from Italy. We Americans are not  
adepts in acknowledging the salutations of those who would acclaim our  
deeds. We accept it all in a matter-of-fact way.

But Savannah, the city, has made good its boast that it could supply an  
ideal automobile course, and, furthermore, guard it. All this occurred on  
Thursday, March 19, two days after St. Patrick's Day had been properly  
celebrated by its many citizens whose ancestry traces to the Emerald Isle.

Yes, Savannah has made good. That is the finding of the automobilists  
who to-day are returning northward. Priority and proximity to the metropolis of the country give to Long  
Island first claim on the classic Derby of automobilizing, the Vanderbilt Cup race. If conditions—some-  
what chaotic at present—make Nassau County, New York State, unavailable, then Chatham County,  
Georgia, has the inside track over all bidders, and has it because the Savannah Automobile Club, the city,  
and the county demonstrated to the officials of the American Automobile Association entire ability to cope with  
every phase of the complicated and exacting situation.

And it was a grand race that the Isotta Fraschini won, persistently pursued by an Apperson, which in turn  
had a battle with the Acme, a new candidate for speed and endurance, while in fourth place was the Lozier, at

ISOTTA WINS CHALLENGE TROPHY  
APPERSON TAKES RUNABOUT CUP  
THOMAS SIX-CYLINDER VICTOR





Governor Smith Eulogizes Strang and Marquess.

one stage a leader, and losing the place through circumstances undeniably exasperating, though all in a day's hard running. Fifth finished the Isotta, originally picked as the favorite of the event. Two others—an American and a Stearns—were still going when Referee Webb concluded the 342-mile struggle. An eighth starter had met with disaster, but this Apperson and its crew suffered little beyond a jolt and a scare.

This contention for the Savannah Challenge trophy took place Thursday, in the presence of some thirty thousand people, a third of whom were located on, or in the vicinity of, the capacious grandstand, in the royal box of which sat Hoke Smith, Esq., Governor of the Commonwealth, and the first Chief Executive of a State to recognize the great worth of the automobile by sanctioning the use of military to guard the course for a motor-driven vehicle contest. Mayor Tiedeman, early wideawake to the opportunity of exploiting Savannah, saw to it that the portion of the course lying in the city limits had efficient police protection. Therefore, the great problem of the past in the conduct of automobile races in this country was answered most satisfactorily.

Wednesday had served to some extent as a dress rehearsal for the big race. An Apperson, piloted skilfully by the experienced Lytle, appropriated the Southern runabout cup, its only finishing rival being a Thomas Detroit "Bluebird," J. B. Lorimer driver; the speedy Pennsylvania, with Zengle at the wheel, having suffered a mishap which took it out of the sputtering argument after the fastest round of the 17.1-mile course.

The six-cylinder duel between the Thomas and the Stearns promised much. But it was the fate of the latter to suffer disablement after a couple of laps, thus leaving the other to score unopposed, which it did regularly and faultlessly.



Some of the Hard-working Official Notables.

Starting on the right: Chairmen Thompson and Van Sicklen, Referee Webb; Director Haynes, Secretary Elliott, First Vice-President Speare, Harry Dunn, Starter Wagner, Assistants Reeves and Rutz.

Savannah's leading citizens were responsible for the success accomplished. President Frank C. Battey, of the Savannah Automobile Club, had no more enthusiastic fellow-worker than Mayor George F. Tiedeman. These two were on the job from early until late, though the honor list contained other indefatigables, including Capt. R. J. Davant, chairman City Council; Major W. W. Williamson, president Chamber of Commerce; Wright Hunter, president Cotton Exchange; W. B. Stillwell, president Board of Trade; A. B. Moore, vice-chairman County Commissioners; J. J. Raders, Harvey Granger, George J. Baldwin, Robert M. Hull and Secretary A. W. Solomon. A loud and unqualified word should be said for Major W. B. Stephens, who handled the military arrangements unobtrusively flawlessly.

It was a joint committee of the American Automobile Association's racing and technical boards which stood behind the Southrons and contributed help in various ways. Chairman Jefferson deMont Thompson, of the Racing board, figured as an honorary referee, along with Governor Smith and Mayor Tiedeman. Chairman Van Sicklen, of the Technical board, came to Savannah over a fortnight before the races, and lent aid day in and day out. Vice-Chairman Frank G. Webb, of the Racing board, was the conscientious referee, and Vice-Chairman David Beecroft, of the Technical board, examined the cars to see that stock chassis requirements were observed. Secretary F. H. Elliott, to whom much credit is individually due for the Savannah undertaking; L. R. Speare, first vice-president, and Directors S. L. Haynes, Charles J. Swain and A. G. Batchelder were of the party which came to the races in a special car on the Seaboard Air-Line. H. M. Swetland, A. B. Tucker, L. Eikwort, Jr., and M. C. Reeves were other officers of the meet on the same train. Starter F. J. Wagner and his assistant, W. A. Rutz, came up from Florida. Announcer C. T. Earl was another "regular" who reported, as usual.

When one considers that though Savannah has a population of about 85,000, some 40,000 are colored, one cannot but marvel at the progressiveness of this picturesque place, which contains much to interest the visitor from the North. Peach trees, suffused with pinkish color and redolent of spring; pear trees, clad in white blossoms and diffusing fragrance, with the yellow jasmine adding to Nature's perfume, prodigious live oaks drooping with Spanish moss; palmettos contributing still more to the tropical effect, all blended into a picture inviting to the stranger. Negroes, shiftless but amusing, completed the atmosphere of the Southland, while Old Sol lent rays which at times became somewhat uncomfortable and supplied burnt faces and peeled noses. But apparently the Northerners hugely enjoyed the visit.

In the preparation of the course nothing was allowed to interfere with making it as safe and secure as possible. Cuts were made across lawns, curves were banked, bridges improved, even built over the road, electric railroads partially suspended operation, and, in fact, everything was made subservient to automobiling's needs. True it is that the hotel accommodations did not come up to the Broadway standard, but two men who were at the Grand Prix of 1906, and sweltered in box-like rooms at Le Mans at \$10 per night, were rather inclined to believe that Savannah did fairly well under the congested circumstances. And even Vanderbilt Cup experiences on Long Island called forth recollections of sleeping on billiard tables or on cots in parlors, temporarily converted into bedrooms—and prices of the get-rich-quick complexion. But Savannah realizes that if it is to become more of a winter resort than it has been in the past, it must provide better than it now has. Something is assured in the near future.

One thing is a certainty, and that is that the members of the Vanderbilt Cup Commission feel decidedly happier than they did a year ago, knowing that if Long Island cannot be the scene of the race, there does exist a city called Savannah, in a county called Chatham, containing therein a course which will be well guarded, well prepared, and most satisfactory for the great automobile race of the year. Governor Smith is progressive, and Adjutant-General Anderson shares opinions that harmonize.





Strang and His Italian Winner in Full Cry on the Most Picturesque Stretch of the Entire Course.

SAVANNAH, GA., March 19.—In recognition of the magnitude of the event and its importance to Georgia's great seaport, and by way of demonstrating how rich runs the true sporting blood in the veins of our Southern gentlemen, Governor Hoke Smith had proclaimed a legal holiday in the city. Savannah stood ready to honor the occasion to a man and Savannah's far-famed fair women to grace the occasion by their presence. The State at large also took an eager interest in the event, and excursion trains from all points poured thousands into town.

The early morning hours gave poor promise of a sunny day. There were threatening clouds and chilly winds, which compelled those whose official business compelled an 8 o'clock start for the course to don heavy clothes and prudently provide themselves with overcoats and mackintoshes.

**Crowd Was Admirably Controlled by the Militia.**

Long before this, however, the militiamen, flagmen and telephone operators in trolleys and automobiles were under way for their stations, and seekers for points of vantage had hurried them in their vehicles, for the course was to be absolutely closed at half past eight o'clock. By 9 o'clock a normal March sun had chased away the clouds and brought joy to the hearts of womankind at the chance to discard wraps for the gay Spring garb that had for weeks been in course of preparation for the great occasion. A half hour later the octette of racing candidates was on hand and drawn up in the order of their start. Far down the long stretch one could see a line of people extending out of sight, all fully 100 feet away from the road, and around the first turn, a quarter of a mile to the east, hundreds massed. At the Isle of Hope and in Thunderbolt, the two settlements on the route, there was a congestion of spectators. Here the efficient militiamen were massed five or ten feet apart. Other soldiers stretched in a thinner line along the open country segments of the circuit. No word of praise can be too high to characterize their discipline and efficiency. The crowd knew they meant business and obeyed. One man sought to cross the track when forbidden and got a bullet in his heel as a souvenir of the military authority that prevailed and that Major Stephen's soldiers intended them to obey orders. When a car stopped for an adjustment or repair, the soldiers kent back the crowd. Even when the Apperson overturned, only enough men to right the car were permitted to approach it.

Sixty flagmen encircled the course, showing the racers "yellow" for danger and "red" for a clear course. They had been re-

hearsed for a week during the daily practice hours. Fifteen telephone stations had been established and manned. "It was a cinch to drive down that aisle of safety," said one of the pilots. "All you had to do was to open her up and let her go."

The grandstand was gay with the A.A.A. banners above and the national colors and flags stretched beneath the boxes. It was set at an angle so every one had an uninterrupted view of the racers rushing down the homestretch. In the vast open field opposite, there were only the press and official stands and three great bulletin boards, on which were painted the scores of the cars by laps, to obstruct the view across the open to the White Bluff road, down which for a mile the racers could be seen in the stirring speed flights and exciting struggles to pass one another. Within that great field were but the megaphone men and the bulletin chalkers.

Savannah's fashionable folk are not early risers, so when 10 o'clock, the hour of the start drew near, the great stand, with its 5,000 seats and 65 boxes, was but half filled, and there were many vacancies in the 50 parking spaces adjoining and extending up the stretch. In fact, it was not until the American, the third car, was sent away, that Governor Hoke Smith and various State and judicial dignitaries drove up in carriages with bared heads in response to the greeting of the standing crowd. Within an hour, though, the stand and parking spaces were filled.

**STORY OF THE RACE BY LAPS.**

**The Start.**—Sharp at 10 o'clock Fred J. Wagner, the A. A. A. official starter, began the sending away of the cars at minute and a half intervals in the following order:

- No. 1. APPERSON JACKRABBIT.....Herbert Lytle.
- No. 2. ISOTTA-FRASCHINI.....Louis Strang.
- No. 3. AMERICAN.....F. J. Tone.
- No. 4. LOZIER.....H. Michener.
- No. 5. APPERSON JACKRABBIT.....Wm. McCulla.
- No. 6. ISOTTA-FRASCHINI.....Al Poole.
- No. 7. STEARNS.....Frank W. Leland.
- No. 8. ACME.....M. Neustetter.

Before the start it was announced that the official measurement of the circuit was 17.1 miles, making a 342-mile run of it for the 20 laps. The contending cars were limited to a maximum piston displacement of 575 cubic inches.

When the last car had been sent away and vanished from sight down the White Bluff road there was a craning of necks for the first racer to reach the homestretch. It was Lytle. He flashed by in 18:35. Forty-five seconds later came John H. Tyson's





Lining-up for Start of the Savannah Challenge Trophy Race on Thursday Morning; Weather Perfect, Highway Likewise.

red Isotta with Christie's old mechanic rushing the pace so fast that it had picked up 45 seconds on the flying Jackrabbit by a lap in 17:50, the fastest of the round. The others were content with a more moderate pace, running from 18:41 for Michener to 19:56 for Neustetter. Tire troubles which afflicted Tone sorely throughout the race began early for the American, reducing the time to 27:51. Leland had been forced to stop and brought up the rear of the procession in 30:03.

**Second Lap, 34:2 Miles.**—Strang was evidently out for a hammer and tongs fight for the lead from the start. Running the round in 17:41, he made up his minute and a half handicap and passed Lytle into the head of the procession and a real lead in the race of nearly two minutes over his nearest pursuer. Leland passed the luckless Tone.

**Third Lap, 51:3 Miles.**—In the third round word was received that McCulla's Jackrabbit had overturned. It had upset in rounding one of the sharp Isle of Hope turns too recklessly. McCulla was pinned beneath the car. There was a rush of ready helpers, who quickly righted the machine and released its pilot, who escaped with a sprained and bruised back. The car was too badly damaged to continue in the race and was soon declared officially out.

Strang had retained his two-minute lead over his nearest pursuer, but Michener had got by Lytle and so had Poole, so far as the order of the procession went. Neustetter had moved up into fifth place and Tone gotten by Leland. As a matter of fact, the Stearns had thrown a tire and torn through a barbed wire fence. Both he and his mechanic, Nick Brewer, were cut up a bit by the barbs, but pluckily continued after plugging the damaged radiator.

**Fourth Lap, 68:4 Miles.**—In this round of sprinting Strang increased his lead by half a minute, while Michener hung grimly to his two-minute margin over the other Isotta. The Acme, which was running on a 19-minute schedule under instructions, had crept up into fourth place through Lytle having to stop to mend with tape a broken oil feed leading into the crankcase. Tone was having more trouble with his tires and had been passed by Leland.

**Fifth Lap, 85:5 Miles.**—Strang pulled away a bit further

from Michener, who hung stubbornly to his two-minute lead over Poole.

**Sixth Lap, 102:6 Miles.**—The Acme stopped as per schedule to replenish fuel and enabled Lytle to make five minutes of his lost ground.

**Seventh Lap, 119:7 Miles.**—Poole was forced to stop and change tires and put in new plugs, the porcelain having broken. This gave Michener a lead of seven minutes and allowed the steady plodding Neustetter to creep up within two minutes of him. Lytle had to change spark plugs and lost what he made up on the Acme. Strang was now leading by fully four miles.

**Eighth Lap, 136:8 Miles.**—The end of this round saw the Lozier, which had been speeding speedily and consistently, in the lead, the only American car to poke its radiator ahead of the Italian. It was but 14 seconds to the good, however, so the struggle was a neck and neck one between the American and Italian cars. When the score was announced there was great excitement over the duel in progress for the lead, the pair being nearly seven minutes ahead of the other Isotta.

**Ninth Lap, 153:9 Miles.**—Strang started in with vigor to overtake the flying Lozier, which had snatched the lead from him through the Isotta having to stop for a change of tires, to such good purpose that he overtook and passed Michener, leading him by a minute and a half at the end of the lap. Poole, by a circuit in 17:39, had gained considerably on the two leaders. Later it developed that the Lozier had run short on oil and its pistons had seized.

**Tenth Lap, 171 Miles.**—With the race half over, it looked almost like a runaway for Strang, for he led Poole and Michener respectively by eight and ten minutes. Tyson's Isotta had averaged 54 1-2 miles an hour. Lytle and Neustetter looked hopelessly far behind, and Leland and Tone, though pluckily persevering, were not to be considered in the chances. The Lozier now had its muchly needed oil. At the halfway point seven of the eight starters were running. The best race yet.

**Eleventh Lap, 181:1 Miles.**—With this lap the fine showing of the Lozier came to an end and its chances of figuring prominently at the finish began to vanish, for its lubrication

troubles put it eight minutes behind Poole's car. Neustetter had increased his lead over Lytle to ten minutes. In fact, it was a bad round for all of the racers but Strang.

**Twelfth Lap, 205:2 Miles.**—Strang now had the race well in hand, and with his lead of 18 minutes it looked all over but the shouting. A good fight for second place was once more on, the Lozier having bucked up a bit and cut down Poole's lead to two minutes. The six-cylinder Acme was plugging along in fourth place.

**Thirteenth Lap, 222:3 Miles.**—Poole got the Isotta running again in fine shape and made a desperate effort to cut down his mate's lead by a lap in 17:31. This brought him within four minutes of Strang and 12 minutes ahead of Michener. Once more it looked like one, two for the imported pair, with the Americans far to the bad.

**Fourteenth Lap, 239.4 Miles.**—Now began Herb Lytle's memorable run to regain lost ground and again place the Apperson among the leaders. From this point to the end of the race the Apperson midget ran every lap but one under 19 minutes. His troubles were over, his tanks refilled, and his tires changed for the final fight for a good place in the race. Neustetter, though, still hung stubbornly to that five minutes lead of his.

**Fifteenth Lap, 256:6 Miles.**—Lytle covered the next lap in 18:42 and crept up to within three minutes of the Acme. Strang still held to his 13-minute margin over Poole, and Lozier was dropping further back to Acme.

**Sixteenth Lap, 273:6 Miles.**—The relative positions of the gladiators remained practically unchanged in this round, except that the Lozier crept up a bit nearer to Poole. Neither Leland nor Tone was scored for this round. Leland had run two laps on a bare rim.

**Seventeenth Lap, 290:7 Miles.**—Calamity overtook Poole in this round and cost him his place among the leaders. There was a stoppage in his gas lead which compelled him to remove his carbureter. It took him 42:40 for the lap, and at the end he had dropped from second to fifth place. Lozier was again in second place, but was 24 1-2 minutes behind the leader. Lytle's

plucky driving had brought him to within a minute of Neustetter, or, to be exact, 46 seconds. Strang was making a run-away of the contest, with a lead of 24 minutes.

**Eighteenth Lap, 307:8 Miles.**—Now began the struggle between the trio of battlers for place honors which most of all made a great race of the contest and will long live in motor road racing annals. Lytle had passed Neustetter and had crept up so close to Michener that the Lozier pilot only held his runner-up place by a little over a minute margin, with Neustetter less than a minute behind the Jackrabbit steersman. The closeness of the scrap is evidenced by the score: Michener, 366:37; Lytle, 367:42; Neustetter, 368:10. When the complete figures appeared on the bulletin boards the spectators woke up to the situation, and from that point on eagerly strained their eyes up the stretch for the coming of the cars and wildly cheered each one as it shot by.

**Nineteenth Lap, 324:9 Miles.**—Lytle was the first to be sighted. He had opened the gap separating him from his pursuers to exactly four minutes. Neustetter was now his pursuer, having passed Michener into a lead of over three minutes. Poole in this round made one last despairing run, and in so doing scored the fastest lap of the race for the Isotta, 16:46. He was hopelessly out of it, however, for one-two-three honors.

**Twentieth Lap, 342 Miles.**—Only an accident could have deprived Strang of the race. In fact, he had completed the nineteenth round before his pursuers had reached the eighteenth post. He had an ovation as he crossed the tape, a winner in 381 min. 30 sec., or 6 hrs. 21 min. 30 sec.

**Great Enthusiasm Marked the Finish.**

Interest in the race was now in the struggle for second place. Lytle met with a wildly enthusiastic reception as he flashed by in 404 min. 37 sec. Hardly less enthusiastic was the greeting accorded Neustetter, who was third in 409:05, and Michener, who finished fourth, in 409:17. Poole captured fifth place in 418 minutes flat. Tone and Lozier were last scored at the close of the 15 laps, or 256.5 miles, the American in 366:30 and the Stearns in 405:24. The Savannahians were heart-



Immediately After Making This Isle of Hope Turn, Pursuing Isotta No. 6, McCulla's Apperson Turned Over.



Appersonians Were Successfully In Evidence.



Owner Kiser, Driver Salzman, Six-cylinder Thomas.



Harry Lozier Was an Interested Observer.



Governor Smith Utilizes a White Steamer.

broken over the bad luck of their sole representative, which Ross Guerard had entered.

It had been the grandest and closest struggle in the history of long-distance automobile racing in this country. Seven out of eight starters were fighting the fight when the race closed, a record of survivorship never even approached in any previous motor road race on either continent.

The winning Isotta, which was equipped with Michelin tires, did not even have to make a replacement during the race and kept its motor running without a stop from start to finish. Its only mishap was the breaking of the starting crank through the strap being too tight.

The Apperson's motor never once stopped running. An oil lead to the crankcase broke, necessitating wrapping with tape.

The Acme ran on a 19-minute schedule. It was stopped in the sixth and ninth laps for fuel and in the eighth for new tires. It was the only six-cylinder car in the race.

The Lozier's troubles had mainly to do with tires, but difficulty was also had with the exhaust, which broke and dragged until camp was reached. It was too hot to be removed by hand. It also had another vital trouble. The car was the same one used in 24-hour races last year and was fitted with two five-gallon oil tanks. Since the stock car only has one tank, the

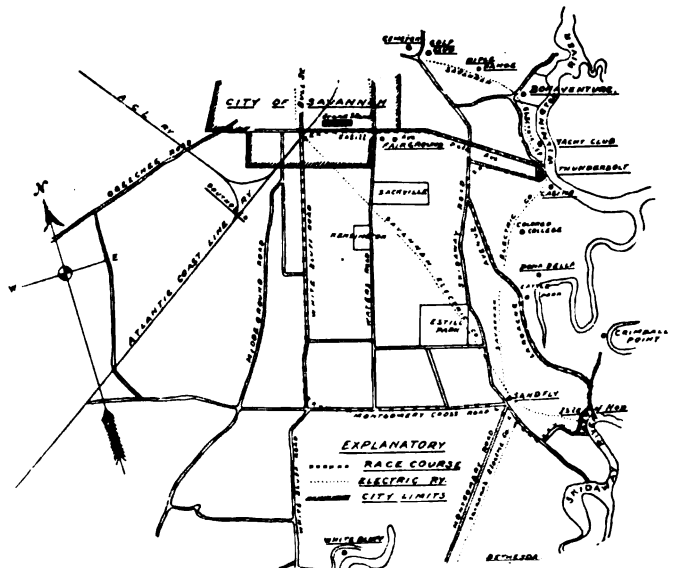

Map of the Race Course at Savannah.

technical officials ruled that it could start with 2 1-2 gallons in each tank. It was figured that the car would go half the distance with this amount, but the estimate fell short, the supply ran out miles away from the camp, the pistons seized, and the engine received a bad wrench.

At the conclusion of the race the victorious Louis Strang and his mechanic, John Marquese, were brought before the stand and introduced to Governor Smith, who, in an eloquent speech, presented them to the Savannahians.

**ST. LOUIS INTENDS TO BID FOR VANDERBILT.**

St. Louis, Mo., March 23.—Despite all the advertising Savannah got because of its tremendous success in running off the three stock car races last week, St. Louis, through the St. Louis Automobile Manufacturers' and Dealers' Association and the Automobile Club of St. Louis, is determined to make a strong bid for the next Vanderbilt Cup race. Scouting expeditions have been out of late looking for a suitable course, and think they have a good one in sight. It is approximately 32 miles in length, starting on the Clayton road at the North and South road, and running to Henry avenue, through the village of Manchester, thence back over Manchester road to the North and South road, and then to the starting point.



First Off on the First Day Was Apperson No. 1, with Lytle at the Wheel.

SAVANNAH, GA., March 21.—Of the thirteen cars that participated in the different events of the Savannah carnival, not one but conformed in all details with stock construction. All of them were not the chassis of touring cars—far from it. Rather, the autoist of to-day is accustomed to seeing almost any kind of chassis and body lines for a roadster car. A few critics in the grand stand suggested that “such and such” was not a stock model, but that was disproved when the interpretation of the rules, which called for the manufacture of five similar cars of that type previous to February 1, 1908, was considered. In the 342-mile event for cars with a piston displacement less than 575 cubic inches, the two Isotta-Fraschinis looked very much like special racing cars with their big gasoline and oil tanks and racy lines, but it was demonstrated to the satisfaction of all that these cars had been manufactured in considerable numbers during the past year, and, like the Renault and one or two other foreign concerns that build racing runabouts, are in reality stock models, as much as the less racy roadster cars turned out by some of the American makers.

It is questionable if the stock phase of the two Apperson Jackrabbits in this same race would not have been questioned if the race enthusiasts had not been aware of the fact that they had been regularly on the market for more than a year. Some question was raised as to the Lozier's eligibility, but Mr. Mead, the company's representative, certified that seven of these cars have been built. In case of the three remaining cars in this event, namely, the American roadster, the six-cylinder Acme, and the four-cylinder Stearns, no question as to their right to contest was raised, their lines being that of standard touring car or roadster.

#### Characteristics of the Most Successful Competitors.

The winning Isotta reached Savannah two days before its race, having been rushed out of customs at New York to take the place of Harding's Isotta that was wrecked. Up to the time it reached Savannah its motor had not been turned over since leaving Italy, and Strang had not driven this make of car before that time. The car in the race showed, however, the careful working out it must have received before leaving the factory. The Isotta is a high-speed engine, of the four-cylinder type, having cylinders cast in pairs with opposite valves. When traveling on the course its motor turns over at 1,800 revolutions per minute, which speed is made possible by the use of exceedingly large flat-seated valves measuring 3 1-2 inches in diameter. Also assisting in this high-speed work are the extremely light pistons, rendered so by perforating them beneath the rings and using a hollow connecting rod. The cylinders have a bore of 145 mm. and a stroke of 120, equivalent to 5 4-5 and 4 1-2 inches, respectively. Instead of using the double ignition outfit employed on all of the other racers, but a single high-tension Eisemann magneto outfit with one set of plugs, is used, the plugs being carried horizontally in the intake valve chambers. In the clutch are 51 discs—25 steel and 26 bronze. These cars on the course consumed a little more oil than the others, requiring all told 24 gallons each for the twenty laps, or close to a gallon and a half a lap. The car is supplied with two sets of brakes, cast-iron shoes, operating against steel drums. The regular brakes on the

jackshaft are 9-inch drums with 3-inch bands, whereas the rear wheel emergency brakes are 11 1-2-inch drums with 2-inch friction shoes. The car has a particularly large exhaust pipe, with a cut-out opposite the center of the chassis. It was shod with Michelines.

Lytle's Apperson which finished second, differs radically from the Isotta's in that it uses separately-cast cylinders with opposite valves, and has a bore of 5 1-2 inches and a stroke of 5 inches. While the Apperson cars do not use such large valves as the Isotta, they have always been known to be among the largest made use of in this country and also to be of the flat-seated type. The ignition employed was a double system, Bosch magneto and battery, with two sets of plugs, that for the magneto over the intake valves and the battery set over the exhaust valves. These cars have a wheelbase of 105 1-2 inches, which is 1 foot shorter than that used on the Isotta's, and which assisted them not a little in making the turns. Diamond tires were used.

#### Showing of the Only Six-cylinder in Challenge Event.

By finishing third, the six-cylinder Acme established itself as a prime favorite, because of its consistent running, the majority of the spectators knowing that it was going according to a pre-arranged schedule. It had the distinction of being the only six-cylinder car in the race, and the regularity of its work was a satisfaction to many. Its motor has six separately cast cylinders, of 4 1-2-inch bore and 5-inch stroke, and intake and exhaust valves placed on opposite sides. Its ignition system combined Eisemann high-tension magneto and a storage battery outfit, with two sets of spark plugs, one set over the intake valves, the other over the exhaust. The lubrication system is confined to a 3-quart mechanical oiler on the dash, from which pass three leads to the crankcase compartments. Its gasoline capacity is 23 gallons.

The 60-horsepower Lozier is a 1907 car, and one that has been seen on the track in 24-hour races. Its external appearance is characterized by a very large cylindrical gasoline tank, carried transversely behind the seat, two 5-gallon cylinder-shaped oil tanks, carried from the frame at the sides, and its white finish. The car has four 5 1-2 by 6-inch cylinders, cast in pairs with opposite valves—typical Lozier construction. It uses a double system of ignition, in which are used Simms-Bosch magneto, and a Witherbee storage cell, with two sets of plugs over the valves. Its oiling system is quite complete, in that three leads connect with the crankshaft bearings and two with the crankcase. The right side oil tank carries a supply which is forced into the oiler by pressure, and the left-side tank is provided with a pump for injecting oil directly into the crankcase.

#### Facts About the Other Cars Participating.

Of the remaining two cars, the Stearns and the American, it might be added that the Stearns is a 1908 four-cylinder car, the same as described last week in THE AUTOMOBILE. The American car, while of the same design as the American roadster, familiarized to the public during the last year, has a larger motor, it being rated at 50-horsepower, and having four cylinders with 5 1-4-inch bore and 5 1-2 stroke. These cylinders are in pairs with valves on the right, and take double sets of spark plugs for the magneto and storage battery ignition system. The lubrication of the engine is cared for by a 6-pint oiler on the dash,



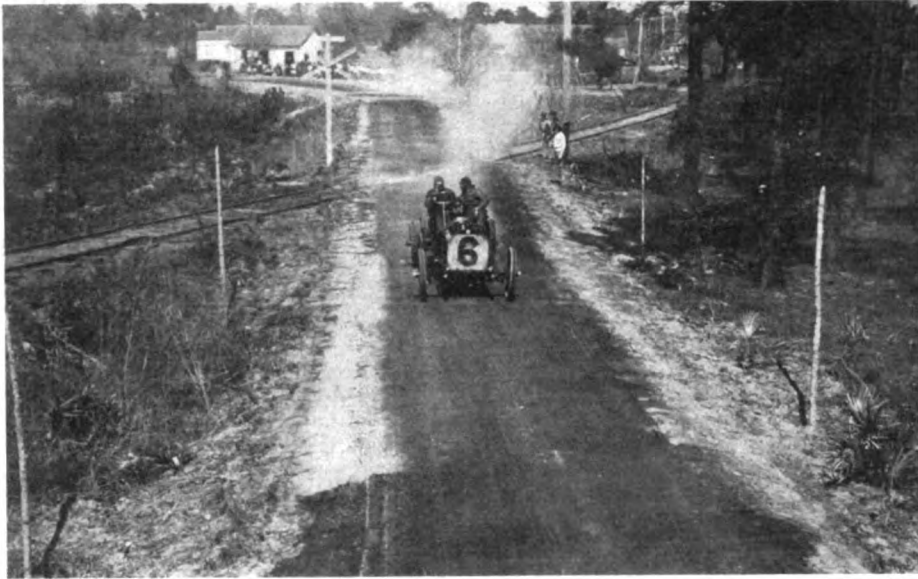

This Railroad Track Was Not Used During the Race.

with a 2-gallon auxiliary tank, carried on the chassis. From lubricator are leads to cylinders, engine bearings, and crankcase.

#### The Six-cylinder Candidates for the Southern Cup.

The two cars that contested in the six-cylinder Southern cup race on the first day were both 1908 six-cylinder machines—the Thomas carrying all the earmarks of the four-cylinder Thomas, and the Stearns having a similar relation to its four-cylinder brother. The winning Thomas has its six 5 1-2 by 5 1-2-inch cylinders cast separately and provided with opposite valves. Its ignition doublet is a Bosch magneto and Atwater-Kent unit, taking its supply from dry cells. The car uses the three-disc clutch common to Thomas machines and drew its gasoline from the standard tank beneath the driver's seat, although it carried a large barrel-shaped gasoline tank in the rear, which during the race was filled with water and aided the car considerably in holding the course. Diamond tires were used. The Stearns six was one of the first the company turned out, and while its cylinders are the same castings as used on fours, yet its motor design is of the 1907 Stearns and not the 1908, as was the case with the four-cylinder car. The other chassis lines were very similar to those employed in the four.



Lozier Passing Grandstand, Leading and Looking All Over a Winner.

#### Those Entered in Runabout Class.

The three cars which competed in the small runabout class, with piston displacement under 375 cubic inches, show widely different methods of construction. Lytle's winning Apperson has 4 3-4 by 5-inch cylinders which are separate castings with opposite valves, the same as employed in the regular Apperson lines. Used on it is a double ignition, with Bosch magneto and storage battery, delivering current respectively to plugs over the intake and exhaust valves. Employed also is the standard band clutch and the three-speed selective gearset. Like the other two competitors in this event, the Thomas-Detroit and the Pennsylvania, it is a shaft-driven machine.

The Thomas-Detroit, which finished second, uses 4 3-4 by 5 1-4-inch cylinders, which are cast in pairs and have both sets of valves on the right side. Employed on them is a Bosch magneto. The Pennsylvania, which met with an accident in

the second lap, is the only car in the three races to use a motor



Soldiers Were Useful and Not Ornamental.

with valves in the cylinder head, as well as transmission incorporated with the rear axle. The four motor cylinders are 4 3-4 and 5 1-4 bore and stroke respectively, which permitted it to get just within the 375 cubic inch limit.

#### Difficulties Met and Overcome.

In recounting the story of the race, it must be borne in mind that the two Isotta cars were reckoned as big factors in it. From what has transpired since the race, it is apparent that Strang went out "to beat" it right from the starting signal, whereas Poole took a safe pace for the first half, and then, perhaps, was ready to strike whatever pace the exigencies called for. Out of the twenty laps, Strang held first place in every one but the eighth, when the Lozier crowded him out by 14 seconds, which lead was to be lost in the ninth, when Strang was leading by 1 minute and 32 seconds. But his position was unsafe during the earlier part of the race.

Everybody had staked pretty liberally on the white Lozier to hold the Isottas,

and the work of it in the first eight laps showed how well such ground was taken. In every one of the first eight circuits, Michener did the work in 18 minutes and a few seconds—a phenomenal record for consistent running. But Lozier's chances ended with the ninth lap. The tenth and eleventh laps were bad, requiring 26:31 and 27:12 minutes, respectively, to go the course. It was apparently at this time that the exhaust pipe connecting with the muffler worked loose, and added to this was the work of refilling with gasoline and oil. For four laps Michener picked up his old pace, but dropped back in the seventeenth, eighteenth, and nineteenth. The last lap was made in 18:57, the car showing its earlier speed when free from the muffler and tire troubles. But while it dropped back into the fourth place, the Lozier was one of the interesting factors in the race. Even when the Lozier's chances against the Strang-Isotta combine were poor, it was an active factor in the



Tires Will Burst, but Nowadays Are Quickly Replaced If of the Demountable Kind.

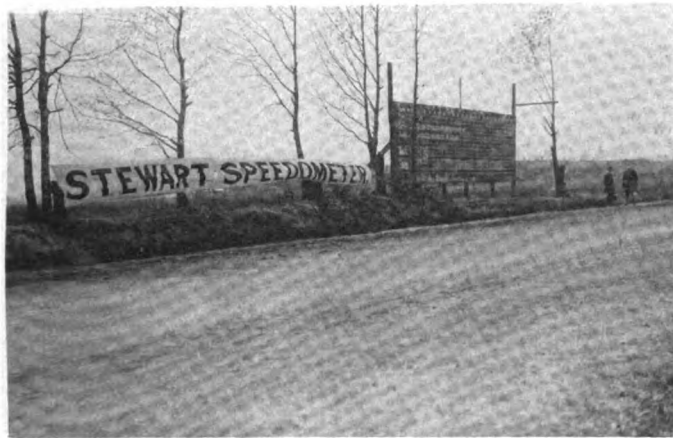

Only Photographers and Officials Allowed Inside.

game, and not until it crossed the finishing line did the spectators know the exact position it held in the field.

When the Lozier dropped from second to third place in the tenth lap, and Al. Poole, with his Isotta, took second place to Strang in the other Isotta, the horizon looked a little gloomy for American machines. Everybody thought that the earlier prediction of "Poole letting loose in the second half" had come true. So it had, but not for long, for he, too, was doomed to disappointment. Spark plugs went back on him, the green porcelain cracked with the intense heat, and, added to this, was the trouble of the compression relief cocks in his cylinder heads working open. Once they opened in the homestretch, necessitating a stop at the east end of the grandstand. Laps seventeen and eighteen clouded all his hopes, and were the turning points of the race in the deciding of what cars would get second, third, and fourth places. Going down the backstretch, his carbureter went back on him. It was necessary to take off the carbureter and clean out the

Apperson-Poole-Acme

gasoline line, which brought the time of the lap up to 42:40, the longest of the day, except for a couple made by Leland when he went the circuit on three tires and had other troubles. This lap took the sights of victory out of Poole's firmament, for, while he worked on the roadside, Apperson, Lozier, and Acme had been flying past; Apperson and Acme climbing up into second and third places with each lap, while Lozier was losing a little, but making certain its position ahead of Poole.

The three-cornered fight between Lytle-Apperson, Michener-Lozier, and Neustetter-Acme was interesting, and a big feature in the second half of the race. It will always prove an interesting chapter in the history of road racing how stubbornly Lytle fought from that fifth position to second. During the "dark ages" of his race, laps four to sixteen, inclusive, he had his little troubles. A copper oil pipe to the crankcase broke and had to be taped; then the hand oil pump for injecting oil into the crankcase broke and matters looked dark; added to these discomforts was the small lubricator that the car carried on its dash, and which is fed from a rear oil tank by pressure. Mechanician Davis pumped oil all the time, and then the motor could not get enough. However, the "long lane" had a turning.



One of the Banked Turns Especially Prepared by the County Road Commissioners.

TABULAR HISTORY OF THE 342-MILE RACE FOR THE SAVANNAH CHALLENGE TROPHY, TELLING TIME BY LAPS AND TOTAL TIME.

No.	Car	H.P.	Owner	Driver	1	2	3	4	5	6	7	8	9	10	11	12	13	14	15	16	17	18	19	20	Total Time	Finished	
2	Isotta	50	John H. Tyson	Strang	17:56	17:41	18:10	17:40	18:42	18:25	22:47	18:02	18:02	18:12	22:35	24:06	26:46	28:14	30:28	31:07	34:26	38:23	38:19	30:57	381:30	6 hrs. 21 min. 30 sec.	1
1	Apperson	50	Apperson Bros.	Lytel	18:44	18:56	18:27	19:33	19:27	24:28	19:01	22:53	23:43	19:46	19:04	19:43	18:42	20:17	18:17	18:17	18:23	18:38	18:17	18:17	404:37	6 hrs. 44 min. 37 sec.	2
8	Acme	50	Acme M. C. Co.	Neustetter	19:56	19:14	19:39	19:42	21:37	19:19	24:33	19:17	22:07	19:33	23:25	19:41	20:19	19:38	21:39	19:30	19:37	19:33	19:22	19:22	407:05	6 hrs. 47 min. 5 sec.	3
4	Lozler	45	H. A. Lozler	Michener	18:41	18:27	18:32	18:32	18:40	18:36	18:46	18:43	19:48	26:31	27:12	19:09	19:09	22:09	18:51	18:46	23:07	23:49	23:53	18:57	409:17	6 hrs. 49 min. 17 sec.	4
6	Isotta	50	Isotta Imp. Co.	Poole	37:46	37:36	37:11	38:15	37:15	42:19	37:33	38:15	37:33	38:15	37:33	38:15	37:33	38:15	37:33	38:15	37:33	38:15	37:33	38:15	401:20	6 hrs. 58 min. 53 sec.	5
7	Stearns	30	Ross Guerard	Leland	50:02	48:27	47:32	48:00	48:00	49:12	48:00	49:12	48:00	49:12	48:00	49:12	48:00	49:12	48:00	49:12	48:00	49:12	48:00	49:12	405:24	Still running when race was called.	
3	American	50	Amer. M. C. Co.	Tone	46:59	46:25	46:13	46:13	46:13	46:13	46:13	46:13	46:13	46:13	46:13	46:13	46:13	46:13	46:13	46:13	46:13	46:13	46:13	46:13	366:30	Still running when race was called.	
5	Apperson	50	Apperson Bros.	McCalla	39:08	39:08	39:08	39:08	39:08	39:08	39:08	39:08	39:08	39:08	39:08	39:08	39:08	39:08	39:08	39:08	39:08	39:08	39:08	39:08	21:25	Car upset and was withdrawn.	

HOW THE POSITIONS CHANGED DURING THE PROGRESS OF THE SAVANNAH CHALLENGE RACE.

No.	Car	H.P.	Driver	Mechanic	1st	2d	3d	4th	5th	6th	7th	8th	9th	10th	11th	12th	13th	14th	15th	16th	17th	18th	19th	20th
2	Isotta	50	Louis Strang	Marquese	1	1	1	1	1	1	1	1	1	1	1	1	1	1	1	1	1	1	1	1
1	Apperson	50	Herbert Lytle	G. E. Davis	2	2	2	2	2	2	2	2	2	2	2	2	2	2	2	2	2	2	2	2
8	Acme	50	M. Neustetter	J. P. Price	3	3	3	3	3	3	3	3	3	3	3	3	3	3	3	3	3	3	3	3
4	Lozler	45	H. Michener	T. Lynch	4	4	4	4	4	4	4	4	4	4	4	4	4	4	4	4	4	4	4	4
6	Isotta	50	Al. Poole	Pepperday	5	5	5	5	5	5	5	5	5	5	5	5	5	5	5	5	5	5	5	5
7	Stearns	30	F. W. Leland	Brewer	6	6	6	6	6	6	6	6	6	6	6	6	6	6	6	6	6	6	6	6
3	American	50	F. I. Tone	J. C. Linn	7	7	7	7	7	7	7	7	7	7	7	7	7	7	7	7	7	7	7	7
5	Apperson	50	Wm. McCulla	Wray, Jr.	8	8	8	8	8	8	8	8	8	8	8	8	8	8	8	8	8	8	8	8



Thomas and Apperson Winners Wore Diamonds

MILES PER HOUR FOR 342 MILES.

No.	Car	Driver	Total Time	Miles per Hour
2	Isotta	Louis Strang	6:21:30	50.70
1	Apperson	Herbert Lytle	6:44:37	46.15
8	Acme	M. Neustetter	6:47:05	45.57
4	Lozler	H. Michener	6:49:17	45.28
6	Isotta	Al. Poole	6:58:53	43.90
7	Stearns	F. W. Leland		
3	American	F. I. Tone		
5	Apperson	W. R. McCulla		

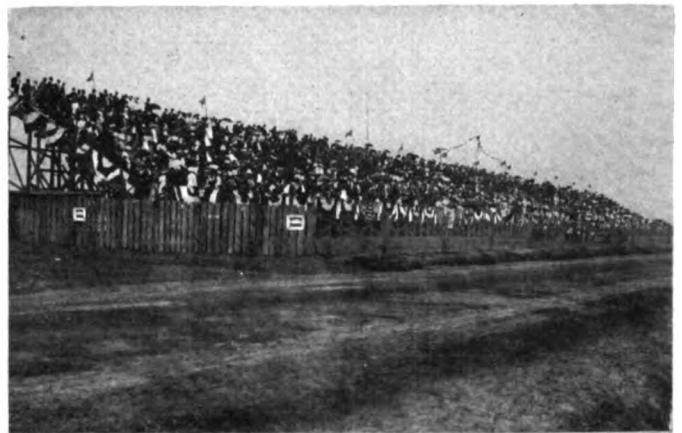

'Twas a Prodigious Grandstand, Well Filled.

FASTEST LAPS AND MILES PER HOUR.

No.	Car	Driver	Lap	Time	Miles per Hour
2	Isotta	Al. Poole	19th	16:46	61.94
2	Isotta	Louis Strang	2d	17:26	59.00
1	Apperson	Herbert Lytle	17th	18:17	56.25
4	Lozler	H. Michener	2d	18:27	55.38
7	Stearns	F. W. Leland	4th	19:05	53.90
5	Apperson	W. R. McCulla	2d	19:16	53.39
8	Acme	M. Neustetter	9th	19:17	53.34
3	American	F. I. Tone	3d	19:26	52.94



In Two Places the Road Was Bridged.





The American Roadster Rounding a Turn.



Stearns Taking One of the Zig-Zag Turns.

## STUDEBAKER AND PULLMAN REACH SAVANNAH

SAVANNAH, GA., March 19.—Mud-bespattered and loaded with equipment consisting of shovels, picks, tackle and the like, all of which showed signs of hard usage, the 30-horsepower Studebaker, driven by Frank Yerger and his brother, Robert, and accompanied by William J. Boyd, as observer, reached here at 4:30 Wednesday afternoon. After officially checking in to President Battey, of the Savannah Automobile Club, the party went to the race course, where they were congratulated by members of the A. A. A. and local enthusiasts, receiving an ovation from the crowd at the stand. The Studebaker also carried dispatches from Commandant R. A. Pendleton, of the League Island Navy Yard, Philadelphia, to Commandant E. D. Taussig, of the Portsmouth Navy Yard, which were delivered en route. The Studebaker's time for the trip was 14 days 8 hours, which represents an excellent performance when the condition of the greater part of the 1,100-mile trip is considered.

The Pullman 40-horsepower roadster, driven by P. T. Gillette and Bob Morton, and carrying A. Daley as observer, did not check in at the De Soto Hotel until 1:35 P. M. Thursday, having required 15 days 5 hours 5 minutes to complete the 1,100-mile journey. After stopping at the De Soto, they drove to the City Hall to deliver a message from Mayor Reyburn, of Philadelphia, to Mayor Tiedeman. Then they visited the scene of the big race, and received applause galore.

The run to Gettysburg and to Washington was made in good time by both cars, and without incident, the drivers not encountering serious work until Centerville, Va., was reached. Both cars were mired several times, and it was a continual struggle through sticky, plastic clay through most of the States. At Fredericksburg, Md., the Pullman was 12 hours ahead, but

by the time Richmond was reached the Studebaker had cut this down to an hour.

From Richmond to Suffolk the cars kept together, reaching the latter place at the same time and leaving in company with Portsmouth as their objective point. The Pullman reached there an hour and a half before its opponent, and as the Studebaker had to wait for repairs, increased its lead, until at Broadnax it smashed the right forward wheel. After stopping for the night at Broadnax, the Pullman went ahead, and never saw the Studebaker again, although the latter reached Savannah first.

The rules of the race, which was run under the auspices of the Quaker City Motor Club of Philadelphia, prohibited the relaying of drivers or departing from the course laid out, and it is understood that the Pullman entrants will prepare a formal protest against the Studebaker on the ground of having violated these rules. This will be presented to the contest committee of the Quaker City Motor Club for action later. The crew of the Studebaker also accuse their competitors of having infringed the rules, and will likewise file a protest.

Some idea of the difficulties of the route may be gained from the fact that on one stretch it took the Pullman 67 hours to struggle through sticky, plastic clay through most of the State. To go 77 miles, and 70 gallons of gasoline were consumed. On frequent occasions, both cars had to enlist the services of horses and mules to extricate them from mudholes which threatened to engulf them entirely, two miles an hour often being considered excellent progress. The worst roads were encountered in Virginia and North Carolina, where a heavy clay soil predominates, the roads getting better as the teams progressed. It soon developed into a day and night race, the crews getting little sleep.



President Battey Greets Studebaker Tourists.



Mayor Tiedeman Welcomes the Pullmanites.





At the  
Festive  
Board  
With Georgia's Governor.

Lytle and the Apperson Southern Runabout Cup Winner.

SAVANNAH, GA., March 19.—Hospitality was unbounded, eloquence ran rampant, and jollity was unconfined at the shore dinner tendered the visiting autoists to-night by the Savannah Automobile Club. It took the form of a Southern shore dinner at the Thunderbolt Casino, to which the guests were carried in autos. The titillation of Northern palates by crab soup and hot Georgia biscuits will ever remain a pleasant memory with the visitors.

His Excellency, Governor Hoke Smith, was there to present the prizes, and prominent State, county, and city officials were also guests. All the talk was of the race, the course, the management, and the chances of the Vanderbilt Cup race coming to Savannah next autumn. Good roads also came in for eloquent exploitation.

Frank C. Battey, the president of the club, presided, welcomed the guests most happily, and then introduced the Governor. His Excellency expressed his thanks to the visitors and also to the Savannahans for what they had done to make the meet a success, declaring it had been of value as well as a pleasure to the whole State. He was most impressed he said by the co-operation of all the citizens in promoting the affair, and the pronounced success which had attended the promoters' efforts.

Messrs. Hamilton, Apperson, and Kiser were then asked to rise and receive the trophies won. Next Strang, Lytle, and Salzman were summoned to receive special bronze medals from the City of Savannah.

Oratory galore followed. Chairman Thompson congratulated the Savannahans on their success. He had seen races in Eng-

land, Ireland, France, Germany, and Italy, and in this country, but none had been better conducted than this one. It took but several hundred Georgia soldiers and a corps of city police to guard the course as effectively as had 7,000 troops the Grand Prix route. The chairman told his hearers confidentially that next to his own State he would vote for Savannah. He said military protection for automobile races cannot be had in New York State because of politics. "Down here you seem to have politics only one way—the good people get what they want," he said. He said that the only trouble he heard of for the whole day was one man who got shot in his toe, "and I suppose he stuck it over the line."

A. G. Batchelder, editor of THE AUTOMOBILE, enlarged upon the value of good roads to Georgia and referred to the excellent beginning in Chatham county. Frank Oliver, counsel to the club, in

the matter of securing the course, said that this race would foster the movement for good roads in Georgia. He stated that the county commissioner had told him he would furnish twenty-five to thirty miles for the course if needed.

Gen. Clifford S. Anderson, of Atlanta, a member of the Good Roads Association, declared it was his aim to have Savannah, Augusta, Atlanta, Macon, and the other cities of the State, connected by a great highway.

Edgar Apperson declared that the industry needed such stock car races, which most helped makers to improve the kind of cars that people want to buy. John C. Wetmore, the dean of the automobile pressmen, made the humorous speech of the evening, his witty remarks creating a whirlwind of laughter and applause. He told the Georgians that their race was the greatest and most closely contested one ever held in the world.

Secretary F. H. Elliott, of the A. A. A., urged the Savannahans to join with the Atlanta and Macon clubs in the formation of a State association and to use their influence with their congressional representatives in the Judiciary Committee in behalf of the Federal registration bill.

N. H. Van Sicklen, chairman of the A. A. A. technical board, confessed to lack of speech-making ability, but said that he was glad to have been of some aid in helping to make the race successful. H. M. Swetland, president of the Class Journal Company, complimented Savannah and told of the early days of automobiling and related experiences with his first car. J. F. Kiser, whose Thomas won the cup for six-cylinder cars, promised to enter all the races the Savannahians should promote.

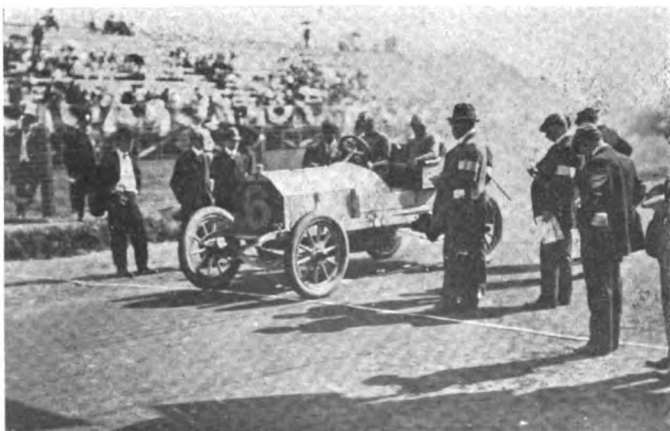

Thomas-Detroit, Second in Runabout Cup Event.

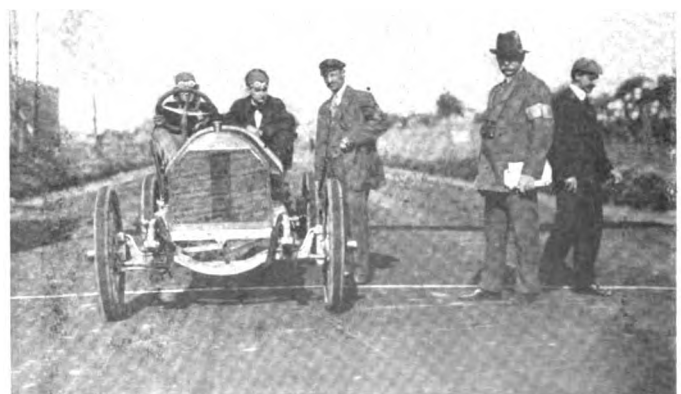

Pennsylvania Which Made Fastest Lap Runabout Event.

Resolutions were adopted thanking all who had been instrumental in making a success of the races, the list being a long one. It was nearly midnight when the party scurried back to town in the moonlight. J. D. Rosenheim was the chairman of the committee having the most enjoyable function in charge.

**SOME SAVANNAH GOSSIP.**

**Savannah Club's President on A. A.**

**A. Racing Board.**—Chairman Thompson has appointed President F. C. Battey, of the Savannah Automobile Club, as a member of the A. A. A. Racing Board. The appointment was deserved, in view of the Savannah outcome, and Mr. Battey is certain to prove a most valuable member.

For the first time in Lexington, known as the Bird Club, has been organized.



Salzman and Thomas Six-cylinder Winner Rounding Isle of Hope Curve.

**NEW JERSEYTES MUST GIRD ON TIGHTENING**

**NEWARK, N. J., March 24.**—The automobilists of New Jersey definitely come to the conclusion that the only way they obtain sane automobile legislation is through most thorough organization over the entire State.

indications point to the probability of the election of W. C. Kirby, of the New Jersey Automobile and Motor Club, as president of the Associated Automobile Clubs of New Jersey, the meeting of which will take place March 31, at Trenton.

A recent letter from Senator Frelinghuysen to Mr. Crosby conveys the information that a recent conference of New Jersey motorists. **McCulla Tells of His Accident.**—Asked about his mishap, William R. McCulla, driver of the Apperson No. 5, said: "I misjudged the speed of my car while attempting to pass the Isotta, and tried to take a sharp left-hand turn too fast. As a result, my car turned over. Absolutely nothing was wrong with the car, and the accident was due entirely to an error in judgment. The only damage done to the car was the breaking of the steering wheel. A temporary repair was made, and the car was driven to the garage under its own power."

**Trials of the First Six-Cylinder Stearns.**—One of the two starters for the six-cylinder event, Wednesday, was E. H. Inman's Stearns, driven by Leland. It was the first of its kind turned out by the Stearns factory, and was equipped with the regular touring gear. Special sprockets had been expressed from Cleveland, but had not been received, so that Leland had to speed his engine up to more than 1,750 r. p. m. This is a terrific speed for an engine the size of the Stearns, and, as it was maintained for some time, the oil in the crankcase became

exhausted, and two of the big end bearings "froze," breaking the connecting rods. In the long-distance race, Leland drove Mr. Guerard's Stearns, but was continually harassed by tire troubles. The car was equipped with the ordinary clinchers and common rims, and at one time Leland ran the Stearns round the circuit two complete laps with but three tires on, which made high speed impossible, the race being declared off before the Stearns covered the total distance. Leland was the only Stearns' representative on the ground. Leland, Oldfield, and Vaughan will be the three Stearns' drivers in the Briarcliff race. Vaughan has recovered from his recent injuries, and is now at the Cleveland factory tuning up his car. Oldfield will be on the course next week. Mr. Stearns says of racing: "Of course, racing is a good deal like fishing—some days you catch fish, and some days you don't."

**How Tucker Sized It Up.**—A. B. Tucker was the publicity man for the Savannah races, and in one of his press sheets, just issued, he comments in this vein: "The races of the past week at Savannah showed a great light for the veterans of the North. When the contingent of American Automobile Association officials, racing experts, and newspaper men arrived at Savannah they experienced a manifest jolt. Much had been written regarding the two days' carnival of speed slated for March 18 and 19, but all that had been published failed to clearly convey the fact that the automobilists of this Southern city, unused to racing matters, and simply following the one rule of 'Thorough,' had made arrangements which could only be described by one word—perfect. The course was the best ever selected in America."



Stearns Six-cylinder Candidate.



In the Shade of the Big Bulletin Board.

# THE AUTOMOBILE

Vol. XVIII Thursday, March 26, 1908 No. 13

## THE CLASS JOURNAL COMPANY

Flatiron Building, Madison Square  
New York City

H. M. SWETLAND, President

### EDITORIAL DEPARTMENT

A. G. BATCHELDER, Managing Editor

R. F. KELSEY, Associate Editor C. B. HAYWARD, Engineering Editor

W. F. BRADLEY

### BUSINESS DEPARTMENT

A. B. SWETLAND, Business Manager

LOUIS R. SMITH FRANK B. BARNETT

W. I. RALPH, 1035 Old South Building, Boston, Mass.

C. H. GURNETT, H. E. WESTERDALE, 836 Monadnock Block, Chicago, Ill.

Cable Address - - - - - Autoland, New York  
Long Distance Telephone - - - - - 300 Gramercy, New York

### SUBSCRIPTION RATES:

United States and Mexico - - - - - One Year, \$3.00  
Other Countries in Postal Union, including Canada - - - - - One Year, 5.00  
To Subscribers—Do not send money by ordinary mail. Remit by Draft,  
Post-Office or Express Money Order, or Register your letter.

### FOREIGN SUBSCRIPTION AGENTS:

ENGLAND:—Hilffe & Sons, Limited, 29 Tudor Street, London, E. C.  
FRANCE:—Boyveau & Chevillet, 22 Rue de la Banque, Paris.  
GERMANY:—A. Seydel Mohrenstrasse 9, Berlin.

Entered at New York, N. Y., as second-class matter.  
The Automobile is a consolidation of The Automobile (monthly) and the Motor  
Review (weekly), May, 1902, Dealer and Repairman (monthly), October, 1903,  
and the Automobile Magazine (monthly), July, 1907.

Copies printed in 1905	- - - - -	730,000
" " in 1906	- - - - -	791,000
" " in 1907	- - - - -	888,900

## GEORGIA HAS AN UP-TO-DATE GOVERNOR.

It is more than likely that the Governor of Georgia, the Hon. Hoke Smith, is, first of all, something of a politician. Otherwise—in the South, where politicians are born in plenty—he would not be the chief executive of that commonwealth.

But automobilists, one and all, without regard to party affiliations, at the present moment would vote for this particular Smith, no matter what office he might seek in the worthy pursuit of saving State or country.

First of all American governors, the Hon. Hoke attended an automobile road race, unashamed of being seen in the company of automobilists, unafraid of the farmer vote—that bugaboo of the apprehensive applicant for ballots—and even adding to the enormity of his crime by issuing an order permitting the use of the State militia in the guarding of the course.

True the thousands enjoyed the greatest spectacle of modern times, true that no one was injured by the motor-driven juggernauts (?), true that the attention of the whole country has been called to the fact that Georgia has roads good enough for the driving of automobiles over them at the highest rate of speed, and, finally, true that the enterprising city of Savannah has had its business progressiveness and charms widely advertised.

But the stickler for the letter and not the spirit of the law will say that Governor and Mayor exceeded the powers entrusted to them by the people. Hair-splitters of any sort are tiresome; they impede and delay advance;

only strong men interpret laws according to the needs of the hour, assuming implied authority and accepting the responsibility therefor. The roads were built for the use of all the people—including automobilists—and Governor Smith recognized that the commissioners of a county and the aldermen of a city were competent to decide if the temporary employing of the highways for the exploitation and betterment of a new type of vehicle intended for general usage did not unduly interfere with the rights of those who utilized the avenue of commerce and pleasure previous to its appearance on the roads.

Here's to the Governor of Georgia, the Mayor and the councilmen of Savannah, and the road commissioners of Chatham county! Though they shall have many imitators, their names are indelibly inscribed on the roll.



## THE PREDICAMENT OF THE OLDEST CLUB

A. G. Batchelder, editor of THE AUTOMOBILE, enlarged upon the value of good roads to Georgia and referred to the excellent beginning in Chatham county. Frank Oliver, counsel to the club, in the matter of securing the course, said that this race would foster the movement for good roads in Georgia. He stated that the county commissioner had told him he would furnish twenty-five to thirty miles for the course if needed.

Gen. Clifford S. Anderson, of Atlanta, a member of the Good Roads Association, declared it was his aim to have Savannah, Augusta, Atlanta, Macon, and the other cities of the State, connected by a great highway.

Edgar Apperson declared that the industry needed such stock cars, which most helped makers to improve the kind of caused the directors of the New York State Automobile Association to accept temporarily a constitutional change which reduced the A. C. A. dues to \$500. But when it was recently made apparent that the dominant figure of the club's exclusive ring was interfering with the State association's legislative program and peremptorily disregarding the acquiescence of the club's duly authorized delegate in the premises, the limits of consideration and toleration had been passed.

Surely the oldest club of the country is in sore straits under its Shattuckian—almost Pickwickian—government, and if a change is not effected the handwriting on the wall of the unfrequented, expensive home will soon be legible even to its short-sighted governors.



## EVOLUTION OF CRANKCASE DESIGN.

Within the past two years it has become noticeable that designers are no longer of one accord concerning that essential of motor design—the crankcase. Evidences seemed to point to the practically universal adoption of the two-piece crankcase of aluminum, and the use of this type is probably more general than that of any other that could be mentioned. There has been more or less talk of abandoning aluminum for this purpose, but thus far it has had no result. Departures have been along other lines. One of these is the adoption of the one-piece crankcase with provision for the insertion of the crankshaft and camshafts, the latter complete with their bearings, from the ends, thus not alone simplifying the motor itself but also facilitating its dismounting and re-assembling. Liberal handholes are provided for main-bearing adjustments, and access to the crankcase.

## A.A.A. WILL SOON CONTAIN 30 STATE BODIES AND 200 CLUBS.

An unmistakable indication of the belief in benefits to be derived from organization by automobilists is supplied in a recent announcement from the secretary of the American Automobile Association, and is most interesting.

**New York.**—The Empire State now leads in the number of automobile clubs, and during the past week the Peekskill Automobile and the Automobile Club of Ulster County, Kingston, were added to membership in the New York State Automobile Association, giving that organization a numerical strength of 43 automobile clubs. The Automobile Club of Mount Vernon was formally organized on Thursday last. The automobilists of Yonkers will form a club in the near future, and autoists of many other cities in New York State have similar plans in view.

**Ohio.**—Automobile Club of Toledo formed, and the Automobile Club of Portsmouth is under formation.

**Kentucky.**—The Automobile Club of Owensboro and another automobile club of Lexington, known as the Blue Grass Automobile Club, have been organized.

**Arkansas.**—The Automobile Club of Little Rock is the first club of that State to organize, and is co-operating with the autoists of Pine Bluff and Fort Smith, who are organizing clubs with the view of forming a State association.

**Pennsylvania.**—The Norristown Automobile Club and the Motor Club of Harrisburg have applied for membership in the Pennsylvania Motor Federation.

**Nebraska.**—Omaha Automobile Club.

**Michigan.**—The Flint Automobile Club and the Automobile Club of Kalamazoo have completed organization, and clubs are also being formed in Jackson and Battle Creek.

**Maine.**—The motorists of Portland and Bar Harbor are expecting to complete the organization of local clubs in their cities within a fortnight.

In many other Southern and Western States similar organization work is being conducted, and it is confidently expected that before the touring season begins there will be affiliated with the American Automobile Association thirty State associations, comprising at least 200 automobile clubs.

### NEW JERSEYITES MUST GIRD ON THEIR ARMOR.

**NEWARK, N. J., March 24.**—The automobilists of New Jersey have definitely come to the conclusion that the only way they can obtain sane automobile legislation is through most thorough organization over the entire State.

Indications point to the probability of the election of W. C. Crosby, of the New Jersey Automobile and Motor Club, as president of the Associated Automobile Clubs of New Jersey, the meeting of which will take place March 31, at Trenton.

A recent letter from Senator Frelinghuysen to Mr. Crosby conveys the information that a recent conference of New Jersey autoists decided that the license fee should be raised to \$2 for cars under 10 horsepower; \$5 for cars from 10 to 30 horsepower, \$10 for any above that figure; drivers' fees to be raised to \$4; no tourists' privileges; manufacturers' fee to be \$5 annually for from one to five cars.

Mr. Crosby comments in this strain:

It will be seen that the automobilists of this State are to get nothing in the form of tourists' privilege, or any change in the present limitation of speed, and will have to pay increased license fees, as well as doubled drivers' license fees; or, to drive a car anything over 30 horsepower will cost \$14 per annum. The cars will, if what is proposed becomes law, have to pay an annual license fee of \$5 per car, limited to five cars. The automobilists of this State must, therefore, acquiesce or fight."

### ANOTHER CLUB FOR N. Y. STATE ASSOCIATION.

**MT. VERNON, N. Y., March 23.**—The Automobile Club of Mt. Vernon is the latest addition to the membership of the New York State Automobile Association of the A. A. A., the organization of the new club having been perfected on Thursday last at a rousing meeting. The officers are: President, William Adams; vice-president, F. A. Merriam; treasurer, Robert M. Van Namee; secretary, F. A. Kately; governors: R. V. Briesen, Wm. McGonigal, W. G. Phillip, J. E. Briggs and A. Schlesinger.

### PROBABILITY OF ANOTHER NEW YORK CLUB.

It is among the assured probabilities that there will be another automobile club in New York City for the borough of Manhattan, the general sentiment of automobilists being that a club is needed in Manhattan belonging to the New York State Automobile Association of the A. A. A. The best results in legislative and other matters are assured through local clubs organized into State bodies. As one automobilist put it: "Just as long as the Automobile Club of America is controlled by a self-perpetuating board of governors trying to make the club national in character, which it is not and cannot be under the existing circumstances, there is positive need for a club in Manhattan Borough to supplement the efforts of the Long Island Automobile Club in Brooklyn, the Richmond County Automobile Club on Staten Island, and the Bronxville Automobile Club in Bronx Borough."

## ONE AUTOIST'S INTERFERENCE IN NEW YORK LEGISLATION.

**ALBANY, N. Y., March 24.**—That new and revised Motor

Vehicle law is not yet introduced, and will not be till the end of the week. It would have been introduced and printed a week ago had not the draft of the bill presented by the New York State Automobile Association been objected to by A. R. Attkuck, without the sanction of the Automobile Club of America, although the legislators thought he was then representing that New York City club. The suggestions he made of an increased registration fee were sufficient to hold the bill and call for several conferences; then the Good Roads and Highway Commission bill came along and occupied the attention of Senator Allds, and the bill has not been touched.

The bill will be amended before introduction to strike the original provisions for penalties for violations by owners and drivers and a simpler penalty provision submitted. The fees for registration, based on weight, will probably remain as they were, or

nearly so, and produce \$300,000 revenue for New York State. The speed limit of the present law will be taken out, and the general common law that no one shall so drive or ride on the public highways as to endanger the life or property of others using the highways will take its place.

It is understood here that the reason for the suggestion to the legislators that automobilists would be willing to pay a registration fee to the State of from \$4 per hundred pounds and up to \$40 a year on their cars is due to the fact that some New York City automobilists, whose residences are in New Jersey, Massachusetts, or Connecticut, but whose autos are assessed as personal property in New York, pay about \$200 to \$235 as a personal property tax on them. Hence, as the proposed registration fee is in lieu of a personal property or other taxation, to pay \$40 to the State instead of \$235 is personally economical to those seemingly most interested in this proposition.





Through the Sage Brush of the Utah Plains.

**THOMAS COMPLETES TRANSCONTINENTAL.**

SAN FRANCISCO, March 24.—Amid scenes of the wildest excitement ever witnessed in connection with an automobile event, the Thomas car made a triumphal entry into this city at 4:30 this afternoon, its total elapsed time in crossing the continent being 41 days 8 hours and 15 minutes, which compares very favorably with the one-man record made under the best weather conditions, despite the fact that the Thomas made a detour of 900 miles to the south, bringing the total distance covered to 3,832 miles. Seldom have contestants in any sporting event been accorded a more enthusiastic reception than was the portion of Harold Brinker, George Schuester and the rest of the Thomas crew. San Franciscans have been awaiting the arrival of the car for several days past, and large crowds waited until a late hour last night. They were out again the first thing this morning, so that when the car finally struck Market street its progress was arrested by the hundreds who wished to personally congratulate Brinker and his comrades, and the police were practically helpless.

The last stage of the continental trip consisted of the 100-mile run from Los Baños here, and it was one of the best stretches in the entire trip since leaving New York. The boulevards in Alameda county were in fine condition, and part of the distance was covered at the rate of 40 miles an hour. There was a large procession of cars for the entire 50 miles from San José. On a smaller scale, the same scenes were enacted in Oakland as here, and it was with difficulty that the Thomas car got to the ferry. The car will remain here for a thorough overhauling, and will be shipped to Seattle in time to take the boat to Valdez, Alaska, which sails on April 1. George Schuester will take charge of the car from now on, and expects to find the Alaskan rivers frozen, so that they may be used as highways, otherwise he does not expect to be able to make a great deal of progress until fall.

The Thomas success is not alone a great triumph for that car, but one of the greatest that has ever been achieved by the automobile, as it was generally predicted at the start that none of the contestants would ever get across before spring. What making the trip across the continent in the dead of winter in such a short time means may be realized from the fact that the Thomas record is little more than eight days longer than that of Whitman and Carris, of 32 days 23 hours and 40 minutes, made in a Franklin.

Daily mileages are becoming greater as the Thomas car gets further West, as on Wednesday, March 18, which was the thirty-sixth

day of the race, the car covered 141 miles, arriving at Ely, Nev., and pushing on 40 miles further before stopping for the night. The telegraph wires were left behind at this point, the next point of communication being Goldfield, Nev., 185 miles distant. The Pierce acted as pilot as far as Ely, the little Reo "rabbit" having lost two tires at Cobre, which could not be replaced. For the stretch to Goldfield, another Thomas acts as pilot car. The Zust, which is now about 500 miles behind, came near ending its chances for good March 18, only the quick wit of the driver and the fact that the axle caught on the brink preventing the car and passengers from going into a ravine.

Goldfield went wild over the arrival of the Thomas, which did not reach there until Saturday morning, owing to being stalled in the mud west of Ely, and later breaking a differential pinion. The whole population stayed up the greater part of the night, awaiting the racer, but was disappointed. The Thomas made the run of 30 miles from Tonopah in 58 minutes, and was greeted on its entry by the ringing of the fire bell, which was the signal for the gathering of the various entertainment committees. The entire town was decorated.

When near Spring Valley, Wyo., the Zust crew found themselves followed by a pack of timber wolves, and only succeeded in driving them off by shooting twenty, the pelts of which will net the ranchmen who gathered them next day some \$200 in bounties. Its arrival in Goldfield placed the Thomas 605 miles ahead of the Zust, which passed Evanston, Wyo., the same day. The DeDion was then at Cheyenne, Wyo., 1,013 miles back; the Protos at Ogallala, Wyo., and the Motobloc at Carroll, Ia., where it gave up and was shipped by rail. The Union Pacific officials would not permit the Zust to use the railroad right of way or go through the Aspen tunnel, because of the damage done the loose gravel ballast by the Thomas. Sirtori was compelled to take his car over the mountains and has made this the ground for a protest.

The car crossed the California line Saturday, March 21, and then had 800 miles between it and San Francisco. It had been expected to reach there in time to take the train for Seattle Saturday night, but the accident on the Nevada desert, when away from telegraphic communication, spoiled its chances. E. R. Thomas, of the Thomas Company, awaited the arrival of the car all day Sunday at Dagget, Cal., but Brinker made a short cut over the mountains to Mojave, where his arrival was quite unexpected. The mileage for the last seven days:

Car	Country	Day 36	Day 37	Day 38	Day 39	Day 40	Day 41	Day 42
Thomas....	(America)....	2,859	2,859	3,065	3,119	3,451	3,632	3,832
Zust.....	(Italy).....	2,390	2,390	2,460	2,536	2,536	2,616	2,636
De Dion....	(France)....	1,690	1,878	2,052	2,166	2,226	2,345	2,390
Protos....	(Germany)...	1,627	1,767	1,878	1,950	2,109	2,109	2,226
Motobloc... (France)....		1,439	Shipped by rail, March 18.					

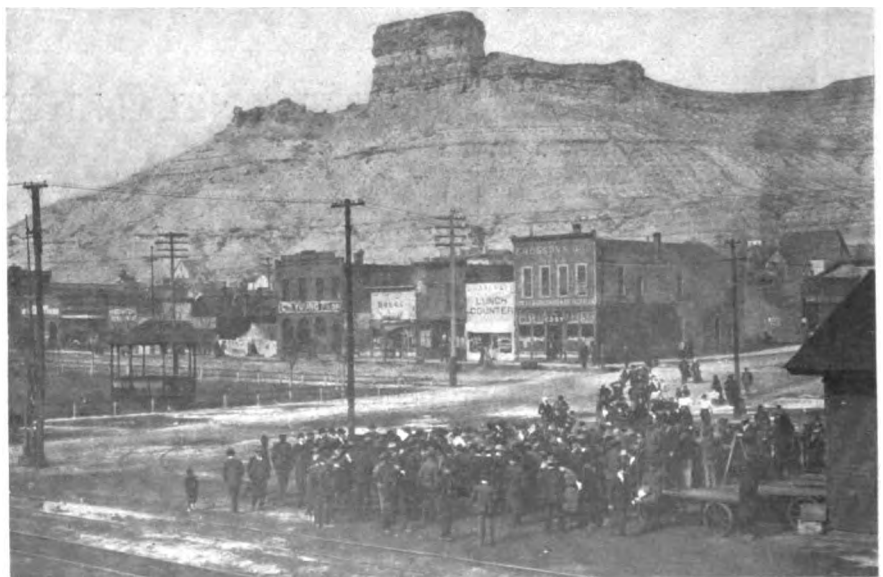

Arrival of Thomas at Castle Rock, Green River, Utah.

# MULTIPLE UNIT SYSTEMS OF TRANSPORTATION\*

By JOSEPH A. ANGLADA, MEMBER SOCIETY OF AUTOMOBILE ENGINEERS.

WITHIN the past few years it has been proven by users in general that, aside from the advertising value of commercial automobiles, which exists in few cases at present, the employment of auto trucks of over 6,000 pounds load capacity is not as profitable as the employment of smaller vehicles. The rapid depreciation of rubber tires in general use, and of the power-generating apparatus, necessitating frequent repairs and replacements, are the chief reasons for the above state of affairs.

A few vehicle manufacturers and users have attempted to solve the problem of expensive tire renewals by the use of various types of wooden and combination tires, and the use of resilient wheels. However, considering that by far the greater number of commercial automobiles of all types are still using and being equipped with rubber tires of the same general type used for the past eight or ten years, it seems that solid rubber tires, expensive as they are in all respects when used on large vehicles, are at present the most satisfactory solution of the problem. An objection to fabric and wooden tires is that, while they perform the work required of them, they disintegrate more rapidly than is commercially allowable, and because of their comparatively non-resilient materials, the tires become loose in the fastenings securing them to the wheels. The inability to absorb the rapid blows produced by encountering small inequalities of the road surface also counts seriously against these tires.

Various forms of combination tires, such as an outer solid tire of a comparatively tough material, which rests upon a pneumatic or spring cushioned part, and spring wheels of various types have been tried, but, as stated above, the old-style solid rubber tire is still the most satisfactory. A form of composite tire is shown by Fig 1. This tire was tried for a while on a five-ton brewery truck, but failed because the parts were not properly proportioned. It consists of a solid rubber tire of the usual form, capable of carrying about one-half the total weight on the wheel. This tire is placed centrally between two steel tires designed to slightly more than carry the balance of the weight. The rubber tire is intended as the traction furnishing and resilient member because it projects slightly beyond the steel tires. The steel tires will protect the rubber when additional loading of same would be injurious. For instance, when crossing a street car track with the ordinary rubber tire the pressure is concentrated on a small section of the tire with occasional injurious results. In fact, in the majority of cases with large vehicles the tires are seldom considered worn out because the tire has worn down to a small cross-section, but because the tire has been split in places and chunks of rubber have been cut out, or the fastening is no longer secure. The steel tires in combination with the rubber should not permit this to occur. However, in my estimation, it will require a long time and the expenditure of a large sum of money to develop a thoroughly commercial tire for a vehicle exceeding three tons load capacity.

Another objection to the use of large trucks is their inability to exert sufficient tractive effort under all conditions of loading and road surface. As a remedy, some manufacturers furnish sand boxes for delivering sand under the driving wheels,

\*Paper read before the Society of Automobile Engineers at Boston.

as in railroad practice, while others endeavor to overcome this difficulty by driving all four wheels. The first method is an unsatisfactory makeshift, while the latter necessitates expensive complication of the propelling and steering mechanisms, with the extra weight of these parts assisting depreciation.

The six-wheel vehicle is a step in the right direction, but the complication inseparable from this arrangement and the expense of building and maintaining this complicated construction detracts seriously from the attractiveness of the six-wheel proposition. Unless at least four wheels are driven, the traction disadvantages of the two-wheel drive are always present. When four or six wheels are driven, the objections stated above also count against this system.

The system employing a tractor and trailers is used abroad to some extent, and has the advantage of distributing the load on a number of wheels. But the objectionable feature of having but one pair of driving wheels counts seriously against the system; because unless the driving wheels are provided with cleats to assist propulsion, it is impossible to haul a paying load at all times, and even with cleats above it is not

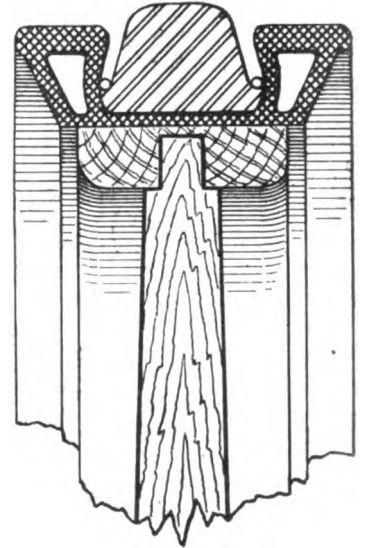

Fig. 1.—Combination steel and rubber tire.

possible if the road has deep sand or mud upon it. The use of cleats is objectionable because they cause the load on the driving wheels to be concentrated on comparatively small areas of the road surface, causing it to deteriorate rapidly.

Colonel Renard realized the shortcomings of the above system when he developed the road-train system which bears his name. It consists of a train of vehicles, the leading vehicle having mounted upon it the power-generating, speed-controlling and steering apparatus. A shaft arranged with the proper number of universal and slip joints extends throughout the length of the train and transmits the power for propulsion to the driving wheels of each vehicle. Thus it is possible to carry a large and, therefore, a well-paying load without having excessively large individual vehicles, causing rapid depreciation of same due to the inability of providing resilient tires or wheels or springs for carrying heavy loads. The road surface is also protected, because the unit load on the same is reduced, the weight being distributed on a greater number of wheels and therefore on a greater area of road surface. In addition, rubber tires are not necessary, because sufficient tractive effort is obtained by the increased number of propelling members. Steel tires may be used on the trailing vehicles, because there is no mechanism except the comparatively simple propelling and steering apparatus mounted on them, and on the leading or power-furnishing

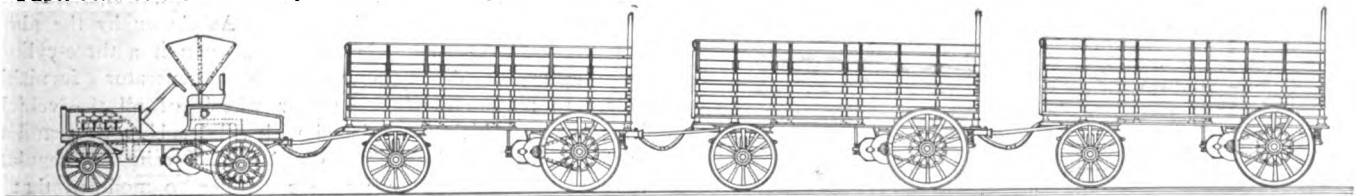

Fig. 2.—Elevation of gasoline-electric power wagon and independently driven, self-steering multiple units.

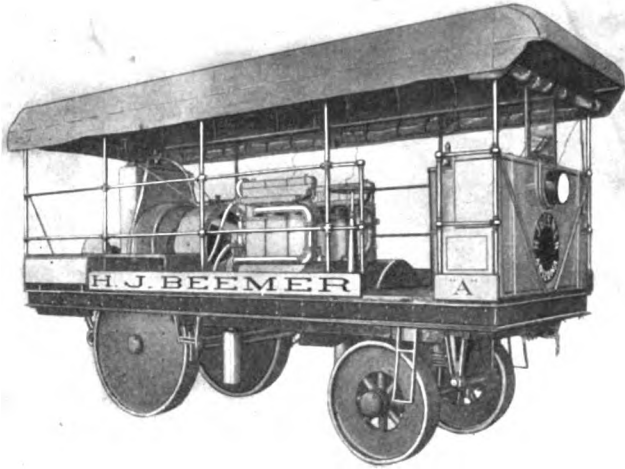

Fig. 3.—Gibbs gasoline-electric power wagon, used for mine haulage.

vehicle rubber tires are allowable, because in no case should the weight of the vehicle complete with apparatus weigh more than three tons. It seems to the writer, after studying the Renard system, that its advantages may be retained and the complication of the power-transmitting and controlling apparatus reduced and these parts made more efficient by the use of the system shown diagrammatically by Fig. 2.

The leading vehicle has mounted upon it the steering and control apparatus, a source of motive power, storage battery, steam or internal combustion motor, but preferably the latter, on account of its simplicity and small weight per horsepower. The motor is coupled to an electric generator which furnishes current to a pair of electric motors on each vehicle. The vehicles are connected by means of a bar which transmits the steering effort from the drawhead at the rear of the leading vehicle to the front axle of each following vehicle. The length of this bar and the position of the front axle are so determined in reference to the rear axle of the leading vehicle, that the entire train follows the same course when turning. The vehicles are also connected by flexible electric conductors, arranged so as to be readily connected or disconnected when it is desired to place a vehicle in or out of the train.

Three methods of control suggest themselves:

First, the ordinary method of operating the internal combustion motor at a constant speed to obtain a constant voltage at the generator, and then, by means of a series-paralleling controller, connecting the fields and armatures of the motors in various combinations, virtually as done in street car and electric

train service on elevated and subway lines at the present time.

Second, a method in which by varying the speed of the generator its voltage is varied correspondingly, causing a proportional current to flow through the motors, making their speed and torque vary.

Third, a method whereby varying the voltage of the generator, by changing its field excitation, its speed meanwhile remaining constant, causes an effect similar to that of the foregoing method. It would probably be found advisable to obtain the field current for the generator from an exciter mounted on the end of the main generator shaft, to save weight, and having its output controlled by the driver of the train.

With the two latter methods, it would also be found advisable to provide a switch for connecting the two motors on each vehicle in series combination for climbing grades and for starting when the train was fully loaded. This switch could also be used for reversing the direction of rotation of the vehicle motors.

The generator should be designed to furnish a direct current at 220 volts and the windings should be so arranged that when the output of the generator nearly equaled the output of the gas motor, the voltage of the generator would decrease and thus decrease the current flowing to the vehicle motors. This feature, while not absolutely necessary, is desirable because at no time is it possible to overload and stall the gas motor by careless operating. For instance, consider that the motors of the train, which are 220-volt direct-current series motors, are operating in multiple combination, and that the train approaches a grade which requires more power than the gas motor can furnish to the motors in multiple combination. The generator voltage would decrease and thus prevent the vehicle motors and the gas motor from being overloaded, and if the driver should persist in not operating the switch to connect the vehicle motors in series combination, the train would come to a standstill if the power required was greatly in excess of what the gas motor can supply. It is seen that by connecting the vehicle motors in series combination the effect of changing to a lower gear of about twice the reduction is obtained with a corresponding drop in speed and increase of torque.

It is generally known that in the existing types of electric commercial vehicles the chief, and, in fact, generally the only feature which prevents them from being ideal is the battery. The motor rarely, if ever, gives trouble and requires little attention; therefore, it seems that, with the exception of the generator, the reliability of which is beyond suspicion, the only other parts of the electric system which might give trouble are the conductors carrying the current to the motors and the controller, of whatever type it may be. The reliability of these is proven by the successful daily operation of such apparatus on railways.

A train such as here described would be useful for many purposes. Besides being adapted for the transportation of goods and passengers in sparsely populated sections, it would be quite suitable for use in congested districts, owing to the ease of control, combined with its ability to accelerate and stop quickly, due to the fact that each vehicle is self-propelled and braked.

The train would not weigh more than a train equipped with an entirely mechanical transmission, and would not cost as much to build. It would operate more efficiently and the cost of maintenance would be less.

In this country multiple unit road trains have been constructed by the Gibbs Engineering and Manufacturing Company and Alden Sampson. The first Gibbs train consisted of a power wagon and two trail wagons. As shown by the photograph, the power wagon has mounted upon it a three-cylinder gasoline engine direct connected to a generator furnishing power to motors driving the rear wheels of all the vehicles. The leading vehicle is equipped with solid rubber tires and the trailers have iron tires. The speed of the train was regulated by a two-motor street car type controller so modified that by operating the drum intended for reversing the car motors, the

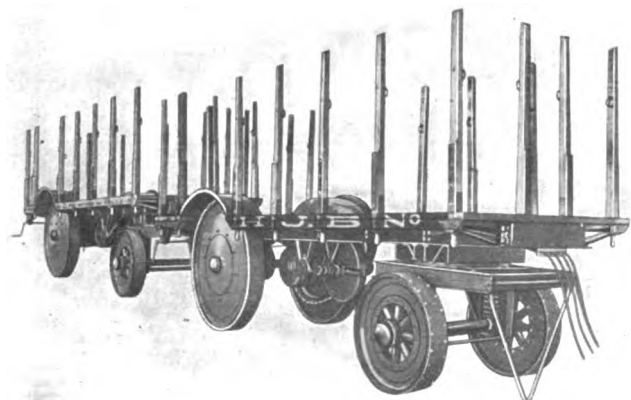

Fig. 4.—Gibbs electric units used with foregoing tractor.

vehicle motors, which were regular series wound electric vehicle motors, would be connected in series or multiple combination. The main drum of the controller was used to connect resistance in or out of the motor circuit. No provision was made for reversing the trailers, but separate switches were provided for that purpose on the power wagon.

The second Gibbs train consists of a power wagon and four trailers. The power wagon has mounted upon it two three-cylinder gasoline engines driving a double commutator generator through positive clutches on the engine shafts and Morse chains. The rear wheels of all the vehicles are driven by series motors through gearing and roller chains. The photograph gives an idea of the construction of the road wheels, which are steel discs flanged at the outer circumference. The discs are riveted to bronze bushed steel hubs and steel tires eight inches broad. Speed regulation is obtained by means of a controller similar to the one used on the first train, with the exception that the controller drum generally used for reversing the car motors is in this case used to connect the two windings on the armature of the generator in series or parallel. The main drum

### ELECTRICAL MEASUREMENT OF TEMPERATURES.

PROFESSOR H. L. CALLENDAR and W. E. Dalby described in a paper recently read before the Royal Society a form of platinum thermometer which measures directly the temperature of the gas in the cylinder of a gas engine at some one point of the cycle, says *The Engineering Digest*. In order to avoid uncertain corrections, it is necessary in any attempt on this problem to employ wires fine enough to follow the changes of temperature of the gas very closely during suction and compression. If such a wire be employed under working conditions, it must be perfectly screened from the flame during explosion. The arrangement designed by the authors is such as to introduce the thermometer into, and withdraw it from, the cylinder at the proper instants, and to do this without making any change in the usual form and extent of the clearance surface during the time interval comprising the end of compression. The thermometer itself consisted of a loop of platinum wire 0.001 inch in diameter and 1 inch long, and a compensation loop of similar wire was provided to eliminate the end effects arising from conduction to the leads. The current employed in meas-

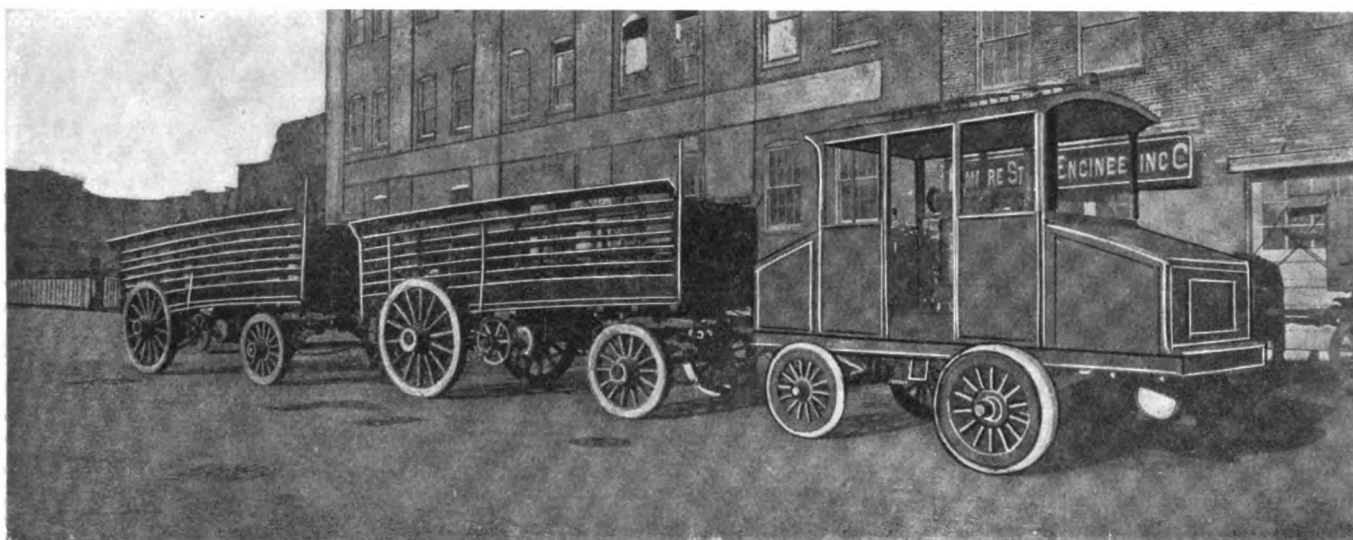

Fig. 5.—Another example of the same type of gasoline-electric road train made by the Gibbs Engineering Company.

of the controller is used to connect resistance in or out of the motor circuit. Each vehicle has a switch for reversing the motors.

This train was used to transport machinery and supplies from a railroad to a mine in Arizona. The route is one hundred and fifteen miles each way and leads through a desert and mountainous country.

The Alden Sampson train, which was exhibited at the last Madison Square Garden show, consists of a power wagon and two trailers, the former carrying a four-cylinder gasoline motor, driving a dynamo by a silent chain. The power plant, which occupies the forward part of the vehicle, is mounted on a separate spring-suspended frame, while the rear part is arranged for carrying a load. All the vehicles are of the six-wheel type, the large center wheels being independently driven on all of the vehicles. In its general features the train resembles the Renard type, the chief difference being that the French train is mechanically and not electrically driven. The trailers are double-ended, so that they may be operated in either direction.

It is a mighty poor plan to come to the conclusion that just because a certain thing about the motor was the cause of deflection but a short time previous, it is again to blame. Some amateurs get "carbureter crazy"; others are afflicted with a streak of "batteries"—they can't imagine a condition of affairs that a bad battery did not contribute to, and so on down through the list, different drivers getting various ailments.

uring the change of resistance (which was practically 1 ohm for 100° C. rise) was about 1/200 ampere. This thermometric arrangement was contained in a small valve inserted through the spindle of the admission valve, which was bored out to receive it. This thermometer valve was introduced into the cylinder by a cam operated by a simple gear. In order to measure the temperature at a definite point of the cycle, a periodic contact-maker was inserted in the testing battery circuit. This consisted of two cams on the same axle and two brushes. The shape of each cam was a flat spiral, which lifted the corresponding springy brush away from the axis as the shaft rotated, and the spirals each terminated with a step which allowed the brushes to fall suddenly. The steps were staggered in angle, so that the brushes fell at different instants. As one side of the electrical contact was carried by one brush, and the other side of the contact by a projection on the second brush, by setting the cams initially at the proper angle, any desired period of contact could be brought about at any desired point of the gas-engine cycle. This method has the advantage that it can be applied without difficulty to any existing engine by simply making a special admission valve. It is absolutely necessary in such investigations that the engine should repeat a perfectly regular cycle at each explosion. No results of any value can be obtained with a hit-and-miss governor in operation, because the conditions vary too greatly from stroke to stroke, and it is manifestly impossible to arrive at any definite conclusions from records made with an engine that is seldom twice the same.



## GYROSTATIC ACTION—ITS EFFECT ON STEERING\*

By WILLIAM W. WATSON, D.Sc., F.R.S.

THE motions of a gyrostat are to most persons a subject of very considerable interest on account of their apparently mysterious nature. The wheel seems, when in motion, to possess volition of its own, and while setting at defiance all the laws of Nature, only obeys some law such as that followed by the Irishman's pig. On account of this mysterious behavior of the gyrostat it has often been suggested as an "explanation" of various events the causes of which are unknown. Thus, when the *Cobra*, the first destroyer to be fitted with turbine engines, was lost in the North Sea, the hull having apparently broken in two, it was suggested that the gyrostatic action of the rapidly rotating turbines had caused such a severe stress as to fracture the hull. In the same way the Salisbury railway disaster was by some attributed to the gyrostatic action of the wheels of the locomotive. Finally, gyrostatic action has been suggested as affecting the motion of a motor-car, and in this paper I propose to consider in what ways and to what extent such an effect is likely to be produced.

An elementary explanation of the action of a gyroscope can easily be given, and will be easily followed if the following considerations are kept in mind. When a body is in motion every autoist is acquainted with what is meant when we say it possesses momentum, and that this momentum depends both on the mass of the body and the velocity with which it is moving; and to change the momentum in any direction, we must act on the body by a force in that direction. Further, the change in momentum produced in a given time is equal to the product of the force which is causing the change into the time. In the case of a rotating body we have a similar set of considerations which may not be quite so familiar. Thus every rotating body possesses angular momentum, which depends on the velocity of rotation, and what is called the moment of inertia, which itself depends on the mass of the body and the distances of the various parts of the body from the axis of rotation. The angular momentum of a rotary body has not only a particular value for any given speed of rotation, but it has also a definite direction—namely, that of the axis about which the rotation is taking place. To change the angular momentum of the body we have to exert a twist or couple, and the magnitude of the change in angular momentum about any axis in a given time is equal to the product of the value of the couple into the time. Finally, we must remember that the angular momentum about any axis may be increased in two distinct ways—either (1) by increasing the speed of rotation about this axis, or (2) by so tilting the body that a spin, which already exists about some other axis, is changed so as to be more nearly coincident with the given axis.

It has often been suggested that the gyroscopic action of the flywheel on an automobile, particularly in the case of horizontal engines with heavy flywheels and having the axis of rotation athwartship, may tend to appreciably assist in preventing side-slip. It has been shown that such an action will only occur if the axis of rotation of the flywheel can tilt when the car rotates. This tilt can only occur by the give of the springs, and it is a matter for calculation to see if any appreciable effect can occur. Although a rigorous calculation would be a matter of enormous difficulty, an approximate solution is quite easy. This approximate solution is sufficient for our purpose, for it will give an upper limit to the quantity required, and, as we shall see, even this is insignificant. The author has taken the numerical data from his own car, which has a single-cylinder horizontal engine.

The weight of the rim of the flywheel is 80 pounds, its outside diameter 20 inches, and moment of inertia 46 foot-pounds, the speed of rotation being 1,000 revolutions per minute. A

couple of hundred pounds at an arm of one foot will tilt the car through seven minutes of arc. Now, suppose the car starts turning, and completes a whole turn in one second, the speed of rotation increasing at a uniform rate throughout. Then the outside value for the gyroscopic couple resisting turning is about six pounds at an arm of one foot. This is quite insignificant, and is so small because of the fact that the springs of the car prevent the axis of the flywheel tilting. This effect was illustrated by a small model car, fitted with a heavy flywheel. When the axis of the flywheel is clamped to the *chassis*, so that the only tilt that can take place is due to the give of the springs, the model side-slips just as badly when the flywheel rotates as when it is at rest. When, however, the axis of the flywheel is allowed to tilt with reference to the *chassis*, only being restrained by a light spring, then the gyroscopic effect comes into play, and the model no longer side-slips.

Another problem is to the effect of the gyroscopic couple called into play when the car rounds a curve. The ratio of the gyroscopic couple to the centrifugal couple tending to capsize the car is—

$$\frac{C n}{V h W}$$

where  $C$  is the moment of inertia of the flywheel,  $n$  its angular velocity (radius per second),  $V$  the speed of the car in feet per second,  $h$  the height of the center of gravity of the car above the ground, and  $W$  the weight of the car. Taking  $W$  as 1,900 pounds,  $h$  as 2 feet 9 inches, and the flywheel being that already considered rotating at 1,000 revolutions; then the ratio at 10 miles per hour is .056, at 20 miles per hour is .028, and at 30 miles per hour is .019. Here, again, the effect is insignificant.

Finally, we have to consider the effect of the gyrostatic action of the front wheels in the steering. When a front wheel goes over a stone the axis is rotated, and hence a couple is produced tending to turn the wheel in the direction so as to steer the car away from the side struck, and this effect tends, with the ordinary form of that axle, to reduce the shock in the steering connection produced by the impact with the stone. Taking a 760 by 90 mm. wheel, which has a moment of inertia of 31 foot-pounds, a car having a tread of 56 inches and proceeding at 30 miles per hour; then if we suppose the wheel to lift one inch while the car moves forward two inches, the gyroscopic couple would be equal to 320 pounds at an arm of one foot. This might be of some effect, only the example taken is certainly an extreme case, for the pneumatic tire would decidedly prevent any such rapid rise of the wheel. Further, as has been already pointed out, the blow of the wheel striking the stone will cause a couple in the opposite direction to the gyrostatic couple. It will thus be seen that under present conditions the gyroscopic action of the various rotating parts of a car produce no appreciable effects. If, in the future, cars are driven by gas turbines, which will almost certainly be of the De Laval type—it may, however, be otherwise.

The model exhibited shows one way in which gyroscopic action may be used to minimize side-slip, but the method is not a practical one, for the size and weight of the gyrostat when used in this way would be prohibitive. If, however, the Brennan arrangement were employed, a comparatively small gyrostat would be efficacious, and in the event of all studded tires being prohibited, might be found worth the additional expense.

From what has been said it will be seen that in the use of the automobile, which, of necessity, possesses such large lateral stability, gyroscopic action is of little practical importance. When, however, we come to the submarine and aeroplane it is quite otherwise, and gyrostatic action will have to be taken into account, or eliminated by the use of twin engines.

\*Paper read before the Royal Automobile Club, London.

## LETTERS INTERESTING AND INSTRUCTIVE

### SOME FRAME WEIGHTS COMPARED.

Editor THE AUTOMOBILE:

[1,256.]—For some time I have been considering the purchase of a well-known American car, which I am satisfied is of the highest grade in every respect, except possibly in the fact that it has a wooden frame. However, the local agents for this car not only claim a reduction of vibration and other merits for this frame, but actually contend that it is stronger and lighter than a steel frame. Now I know that in the earlier history of the automobile industry wooden frames were very common, yet to-day only a few manufacturers persist in using them. Surely there must be some very good reason for this, and, if there is, naturally I am going to consider it in the purchase of a car. So I am writing to ask you your opinion on the wood frame matter, with a view to learning on good authority whether it really possesses the advantages claimed—especially the ones I have mentioned—and of finding out what the objections are that offset these advantages.

Covington, Ky.

CARL MILLIKEN.

The great objection to the wood frame always has been the difficulty of making the various attachments between its parts and the elements that must be mounted upon it as strong as the wood itself. Wood, of properly selected and high qualities is, weight for weight, one of the strongest structural materials known, comparing favorably with alloy steels in this respect. This is because its porous microcellular structure is practically equivalent to an enormous number of minute trusses, by means of which weight is kept down and resistance to transverse, compressive and torsional stresses, as well as to those of tension, is abundantly provided. An idea of what this amounts to practically can be had from the fact that an ordinary channel frame member four inches deep, two inches wide and one-eighth of an inch thick weighs more for each running inch than a solid pine beam two inches thick and eight inches deep. In this connection it is interesting to note that some of the very lightest wood—pine, spruces, ash, etc.—are the strongest; oak, hickory, and other hardwoods, though stronger for a given size, being less strong in proportion to their weight. A further advantage of wood over most steels is its dynamic resistance, it never fracturing without considerable bending and ample warning. It is, moreover, both easier and cheaper to repair. As for the merit of wood frames on any particular car, the question is one to be decided largely by individual preference and by the reputation of the manufacturer. A few designers have undoubtedly perfected remarkably substantial methods of joining wood frames together, and, though it is true that these frames are found in only a few makes of cars, it is to be remembered that some of these makes are ones especially noted for enormous outputs of most serviceable machines, so that the wood frame is regularly giving satisfaction in many quarters.

### FURTHER CORRECTIONS FOR DR. HARD.

Editor THE AUTOMOBILE:

[1,257.]—In the issue of March 12, letter No. 1,229, signed by A. D. Hard, he says, "the faster the wheels turn the motor, the greater will be the resistance to be overcome, and the slower the car will move," and then says, "if we wish to use the motor as a retarder to car movement, we will get the greatest service by using high gear." If he means maximum braking effect by "greatest service," it seems as if he has made a mistake, even if he is a mechanical engineer and writes on the practical side, for the motor will be turned faster by the car on the low gear than by the same speed of the car and the high gear. It is a natural mistake, but high gear doesn't mean a big gear ratio between the engine and road wheels, but a small difference in speed between the engine and the wheels.

Kingston, R. I.

Mr. Hard is an "M.D.," not an "M.E.," the latter being a typographical error that went through unnoticed in the issue in which the letter referred to was published.

A SUBSCRIBER.

### CAUSE OF LAMP MIRRORS BREAKING.

Editor THE AUTOMOBILE:

[1,258.]—An acetylene headlight that I use on my car has been found to have a cracked mirror, which I contend must have resulted from an original flaw in the glass or some similar cause, as there has been nothing else that could have produced the break. The matter has been the occasion of some argument with the dealer who sold the lamps, he contending, in justification of an unwillingness to replace the mirror, that it probably broke from heat, as by putting in too large a burner or by having too great a gas pressure. Since the lamp has been in use for some months under absolutely uniform conditions, with the gas supplied by a carefully regulated Prest-O-Lite tank and there has been no change in burner or adjustments, I cannot see it this way, and would like to know if you can suggest anything that will be positive evidence of just what occurred. I have always understood that these mirrors are of a heat-proof glass and that it is not possible for them to crack in the manner of an ordinary lamp chimney unless flawed or defective to begin with.

JOE FINK.

Atlanta, Ga.

The fact, as you state it, that the lamp was in use for months without trouble constitutes proof that is almost positive to the effect of something happening just prior to the breakage. There is no such thing as heat-proof glass, the heavy lead glass usually used for lens mirrors being simply more heat-resisting than other kinds. But even it will break when unequally heated to a sufficient degree, which might have resulted in any one of several ways. Have you lit the lamp since the mirror broke? If not, we think you will find that the arm of the burner tip nearest the mirror is stopped up from dust or carbonizing, with the result that the flame from the opposite arm has not been stopped by the other impinging upon it, but has shot across and overheated the mirror. This is a common cause of the trouble you speak of, and can happen when the rear arm is completely obstructed or just enough so to destroy the balance of the flame.

### WIRELESS TELEGRAPHY IN AUTO ENGINES.

Editor THE AUTOMOBILE:

[1,259.]—Can you tell me if any satisfactory explanation ever has been offered for the increase of power that results with both sections of a double ignition system working at once? I have a car fitted with both high and low tension ignition, and I find that when it is running on either ignition, set switching or the other, in addition gives a material increase on the power—especially noticeable in hill climbing, for instance. At first I thought the effect was due to the more rapid ignition of the magneto that furnishes the low tension ignition, but subsequently I found that the same result was produced when, while running on the magneto, the battery system also was brought into action. I am pretty familiar with most ignition theory and practice, and am especially disinclined to subscribe to the "fat" spark creed, which might afford a possible explanation of the condition which I have encountered and which I am led to understand, has befallen the experience of many other car users. An electrical engineer of my acquaintance suggests that the merit of two ignition systems, whether twin or different, may possibly be due in some way to Hertzian waves produced by one discharge, breaking down the resistance adjacent to the other—a sort of wireless telegraph effect, so to speak. And this friend further advances the startling opinion that the merit of the once popular spark gap may have had its explanation in a similar principle. Do you know of any data—corroborative or contradictory of these suggestions—that throws any light on this interesting subject? I am sure that there are many others besides myself who will read any information you can dispense or produce.

Austin, Texas.

C. E. ENGLEHART.

Your letter certainly raises a number of interesting questions, upon which we shall be pleased to have our readers' comment. The idea of a Hertzian-wave effect, while at first consideration apparently very far fetched, may after all have much of merit in it. This much is certain—there is no man living who knows all that really goes on within the cylinders of an internal combustion motor, which being the case, no one can deny much more

positively than another can affirm the supposed facts on any given proposition of sufficient abstrusity. Some time ago a Frenchman patented the idea of employing a disruptive discharge outside the cylinders for the purpose of lowering the resistance inside, but beyond this single fact we know of nothing definite on the subject. A very little experimenting would throw more real light on the matter than pages of speculation, and it is not impossible that some information may be in possession of people who will read this. For instance, some one may have noted whether or not there is a difference in the value of the spark gap at different distances from the cylinders. It assuredly could be argued that if a fairly powerful discharge can be made to procure a lowering of the resistance between loosely-contracted iron filings thousands of miles away, at least as much might be expected from a less powerful discharge, acting upon a very short air gap only a few feet away. And the fact of the effect appearing, despite intervening walls of metal, would be no violation of anything that is known of the principles involved in wireless telegraphy.

### MORE ABOUT BRAKING WITH THE MOTOR.

Editor THE AUTOMOBILE:

[1,260.]—I am inclined to think that Mr. Hard has made a slight mistake in his letter No. 1,229, relating to the use of the motor as a brake. Accepting the theory that the braking effect is produced by friction of motor action, I believe that we would secure greater resistance by placing the low gears in mesh instead of the high, which he suggests. Mr. Hard can certainly see that the motor would revolve more rapidly, or a greater number of times in a given distance of car travel, by driving it through the low gears than by driving it direct or through intermediate gears, consequently more friction would be produced, which is the desired result. His statement in regard to using the motor as an emergency brake after coasting with motor released, while true in a certain way, is slightly misleading. The impression is given that if in an emergency it should be necessary to use the motor, the liability of damage to gears and motor would be less by using the low gears. Owing to the great difference in peripheral speed of the low speed pinions, the liability of damage would be greatest in using this set and in a descending ratio until least in the high speed direct drive, where the shock is taken by a jaw clutch instead of gear teeth. This correction applies more generally to the sliding gear types of gear changes, but is true of the planetary as well. I do not believe that good practice will permit of motor-braking through any gears other than direct drive.

In case I am wrong in this, I would thank you for an explanation.  
ANONYMOUS.

There is naturally less resistance to be opposed to a shock when the motor is started with the high gear engaged than when one of the lower speeds is being employed, and we believe it to be quite general to coast with the direct drive in when using the motor as a brake, although instances are not wanting where the low gear is utilized, especially if the hill be particularly long and steep in order to afford as much assistance as possible to the running brakes.

### RELYING UPON A MAGNETO ALONE.

Editor THE AUTOMOBILE:

[1,261.]—Can a good magneto alone be relied upon for ignition, without having a battery and coil for reserve? Is there any disadvantage in using leather treads studded with steel rivets? If it is a good thing and cuts tire expense in two, why don't practically all owners use them, especially as it reduces the liability of puncture? Is a cast iron exhaust valve head any better than a one-piece forging? Does a two-cylinder engine have any more than double the power of one cylinder? Some say it does and others say not.

Peru, Ind.

A great many foreign cars in use on the other side—thousands in fact—have no other form of ignition than a magneto. Tires, or treads, of this type consume considerably more power in driving the car than where plain treads are used, and we do not believe the life of the tire is as great when they are used, though they prevent punctures and similar unpleasantness. Whether a cast-iron exhaust valve head is better than a one-piece forging will depend upon the material employed in the forging. For a cheap form of construction the valve with cast-iron head gives satis-

factory service, as the material is heat-resisting to a high degree. One-piece forgings are frequently made of nickel-steel and other alloys having similar heat-resisting properties. A motor having two cylinders of the same dimensions, and operating at the same compression and speed, should give approximately double the power of a single-cylinder motor of the same characteristics, it being customary in figuring the horsepower of multicylinder motors to calculate that of one and multiply by the number of cylinders.

### REGARDING PUMP SYSTEMS OF FUEL FEED.

Editor THE AUTOMOBILE:

[1,262.]—Have automobiles ever used a pump and distributor in place of a carbureter to supply fuel to the cylinder? I never heard of one doing so, and there must be some great disadvantages in the system or some makers would undoubtedly give it a trial. Some such simple variable stroke pump with distributor, as was outlined by Mr. Lougheed last summer in "Motor Age," would seem to be far simpler and more reliable than a carbureter. The fact that the most efficient engines in the world, the Antoinette and Diesel, employ this means proves that it can be used, and used satisfactorily, too. What are the objections to its use on automobiles?

Evanston, Ill.

EVANSTON.

We do not know of any such system ever having been used on an automobile motor, but the mere fact that no builder of cars has seen fit to give it a trial cannot be taken as evidence that it has any great inherent disadvantages. Automobile manufacturers are in business chiefly to build and sell automobiles, and in order to do this successfully, they must work along the lines of least resistance, which means giving the public what it wants. There does not appear to be any reason why such a system cannot be successfully applied to an automobile motor, but as long as fuel costs are not excessive and the carbureter is fairly efficient, the demand for improvement will not be keen. Auto buyers had their fill of investing in experiments in the early days, so that a car to sell nowadays must be along currently approved lines. Improvement is not the work of a day, but must come as the result of development and evolution, and they represent a tedious and expensive process that the average maker does not wish to bear the cost of.

### USING OLD SHOES AS TIRE PRESERVATIVES.

Editor THE AUTOMOBILE:

[1,263.]—As a subscriber to your valuable magazine, I would like to take advantage of your columns open to those seeking information. Is it practicable to put an old shoe over the tire on a car and hold it in position by lacing it to the wheel? In my locality there is a great deal of rough stone on the roads, which is very destructive to tires. If an old shoe could be strapped over the tire proper, it would take up all the surface cuts, which now ruin my tires very rapidly. I am aware that the resiliency of the tire would be somewhat affected, but the saving in tire expense would compensate me for that. If practicable, what size shoe would best fit over a 28x3 tire? Also, would the slight increase in the circumference of the driving wheels materially affect the gearing?

Grantwood, N. J.

F. P. W.

At least one case has come to our attention where this has been done with very satisfactory results. The experience in question was outlined in a short article by A. D. Hard, M.D., a Minnesota doctor, and appeared in THE AUTOMOBILE during the first half of 1907. If we recollect aright, Dr. Hard's procedure was simply to take an older shoe that was no longer fit to serve as the sole outer covering of an inner tube, and by means of holes punched along its edges, lace it directly over the complete tire, this applying particularly to the rear wheels. According to his account, the resiliency of the tire was not affected to a very marked degree, and the saving was considerable. The increase in diameter would not have any appreciable effect on the gearing of the car. Discarded shoes of the same size were used.

### ABOUT AUTO TIRE PUMPS AND COMPRESSED AIR.

Editor THE AUTOMOBILE:

[1,264.]—Is there any power pump manufactured and for sale which gives entire satisfaction by which you can pump your tires with the motor of an automobile? You advise a Spencer pump. Is it satisfactory? A short time ago I saw a statement in "The

Automobile" telling of cleaning carpets with the motor of an automobile by a San Francisco concern. Can you give me any more information about it? If carpets can be cleaned by the compressed air of an automobile, it is one of the greatest boons to the home in this generation. If the required apparatus for this work is not manufactured and for sale, a splendid field is open to somebody. We have had our homes cleaned by compressed air, with fine results, by a cumbersome machine which made it very expensive. Pasadena, Cal.

A. I. GAMMON.

There are a number of such pumps on the market and, so far as we know, most of them have proved satisfactory in service, though we cannot lay claim to having had personal experience with any of them. When it is a matter of inflating a five-inch rear tire to the required pressure when near the close of a long day's drive, a power pump is certainly a friend in need. The idea of house, or carpet-cleaning, with the aid of an automobile is not novel, as outfits of this kind have now been in steady service in New York City for three or four years past. A vacuum, instead of compressed air, is generally employed, and after arriving at the point where the work is to be done, the auto engine is used to drive the vacuum pump and various lines of hose are led to the rooms to be cleaned. The vacuum sucks the dirt into the pipes and deposits it in a tank of water on the car.

**ROUTE FOR ACROSS NEW ENGLAND TRIP.**

Editor THE AUTOMOBILE:

[1,265.]-Will you kindly answer in your next issue the following: I have a party who is intending to make a trip down through Maine from Stamford by way of Springfield, Mass. Can you or any of the other readers of this magazine give me the best route to take, and if I will have to register in States I pass through. Stamford, Conn.

F. N. P.

The principal route would be along the shore line to New Haven, then up through Hartford to Springfield. From the latter point there are a number of routes, the best leading through Worcester, Northboro, Marlboro and Weston. From Boston, there is a still greater number of routes to choose from, the main line running through Lynn, Salem, Ipswich, Newburyport, Mass., Portsmouth, N. H., and Biddeford and Saco to Portland, Me. The directions beyond the latter city will depend entirely upon the destination of the trip. The entire route from Stamford to Portland, with the exception of comparatively few miles, has been rewritten for the 1908 edition of the "Official Automobile Blue Book," which is now in press, and will be ready by April 1. In addition, it gives complete detailed information concerning the roads, garages, hotels and State laws. Your Connecticut registration will be good for the trip.

**ARE THERE ANY SUCCESSFUL AIR-COOLERS ?**

Editor THE AUTOMOBILE:

[1,266.]-Are there any thoroughly successful air-cooled motors built? If so, by whom? If not, is there a demand for an air-cooled motor that will do all that a water-cooled motor will? Mt. Zion, Ind.

G. W. BROWN.

Your query savors of a rare lack of knowledge of what has been going on in the automobile world during the past five or six years. Have you never heard of the Franklin, Knox, Marmon, Corbin, or Frayer-Miller cars? The many hundreds, if not thousands, of these makes that are in daily use in all parts of the country would appear to be ample evidence of the fact that successful air-cooled motors are not a rarity by any means.

**IRREGULAR FIRING OF ONE CYLINDER.**

Editor THE AUTOMOBILE:

[1,267.]-I operate the two-cylinder Autocar-1907 Runabout—and for some time I have observed that by cutting out cylinder No. 2, by holding down the trembler when the motor was at good speed, the engine would almost or perhaps quite stop running. To give cylinder No. 1 the same speed requires much earlier spark and more throttle than does No. 2 for the same speed. The lack of harmony in velocity of the two cylinders, of course, results in loss of power, and perhaps may damage the power plant finally. The ignition does not seem at fault, as I can trade lines and coils without remedying the sluggish engine and without retarding the more

active one. The exhaust and inlet valves have been scrutinized and the compression is good. Have I loose connections at the piston end of crankshaft, or what must I look for next?

Farmland, Ind.

L. N. DAVIS, M.D.

Judging from the description you give of the trouble, we should put it down, either to the carbureter, or to the manifold, and probably it is more apt to be the latter. See if there is a leak in the manifold where it enters the first cylinder, or any other reason why that cylinder does not get the same amount, or the same quality of fuel as does No. 2, which runs satisfactorily. Irregular working of this nature is most often traceable to the fuel supply.

**WANTED: AN IMITATION RADIATOR FRONT.**

Editor THE AUTOMOBILE:

[1,268.]-Will you kindly let me know where I can buy an imitation front part of hood to represent a water-cooled machine? I am repairing an air-cooled hood and want the front piece to hide the motor and represent a water-cooled machine. New York.

JOHN A. WESER.

If you will look through our columns you will find the announcements of makers of such parts, or if this letter comes to their attention we will be pleased to forward any information they care to supply.

**REGARDING VERTICAL AIR-COOLED MOTORS.**

Editor THE AUTOMOBILE:

[1,269.]-Please tell me the name of a four-cylinder, vertical, air-cooled car that has a forced down draft pipe to each cylinder? Also please give me the name of some four-cylinder, vertical, air-cooled cars other than the Corbin. Rockdale, Tex.

PRESTON H. PERRY.

This is the Frayer-Miller.

The Franklin, Knox, Aerocar, Cameron, Marmon, Logan. Probably there are others that we do not happen to call to mind at the moment.

**DEVELOPMENT OF THE AUTOMOBILE.**

Editor THE AUTOMOBILE:

[1,270.]-Could you give me the name of a book on the subject of "advance in automobile construction?" I would like to get a book that describes the old makes of machines and their inventors, as I have been asked to write on the subject. Plymouth, Ind.

FRED. H. KUHN, JR.

Probably Homan's "Self-propelled Vehicles" will give you what you want in this connection.

**INFORMATION ON FRICTION SUPPLIES WANTED.**

Editor THE AUTOMOBILE:

[1,271.]-Will you please send me addresses of firms where I can obtain friction paper, strawboard, etc., suitable for fillers of friction wheels? Kenesaw, Neb.

C. G. SCHLEGEL.

Will some advertiser or subscriber please come to the assistance of Mr. Schlegel by furnishing the information desired?

**ANOTHER IDEAL "CAR OF THE FUTURE."**

Editor THE AUTOMOBILE:

[1,272.]-Being a subscriber of your most valuable paper and interested in former articles appearing in the same on the subject of the "Car of the Future," would like to give my ideas along the same lines. Having been in the automobile business from almost the beginning, bulder of one car in the earlier days, and also an old bicycle man, I thought my article would probably interest some of your readers, to a certain degree anyway. The specifications of my ideal or "car of the future" are as follows:

Axle.—(Rear.) Live, and of the full floating type. Annular bearings throughout; (front) I-beam section, ball bearing, steering knuckles, roller bearings in front wheels.

Frame.—Ashwood, selected, reinforced with steel radius rods, etc., nickel steel.

Springs.—Full elliptic, 40 inches long, clipped. Front and rear the same.

Wheels.—34-inch, selected, white hickory, artillery pattern.

Tires.—34 inches by 4 inches front and rear, on detachable rims.

Brakes.—Double-acting on transmission shaft, operated by foot pedal. Two double-acting, one on each rear hub, operated by hand lever.



Tank Capacity.—14 gallons gasoline; 1 gallon lubricating oil.  
 Tread.—56 inches.  
 Wheelbase.—100 inches.  
 Motor.—Two-cycle, four-cylinder, 3 3/4 by 3 3/4 inches, having only nine moving parts, four pistons, four connecting rods, one crankshaft.  
 Cooling.—Air, copper radiating flanges on cylinders, etc., fly-wheel suction fan in rear.  
 Lubrication.—Oiler, gear driven from crankshaft.  
 Carbureter.—Float feed, auxiliary air inlet, needle valve, adjustable from the seat.  
 Ignition.—Atwater-Kent system, with dry batteries.  
 Spark Plugs.—Glass base.  
 Control.—Spark and throttle levers on top of steering post; also foot accelerator.  
 Starter.—Cylinder primer located on dash, so as to start from the seat.  
 Transmission.—Selective sliding, three forward and reverse, ball bearing.  
 Clutch.—Expanding ring.  
 Drive.—Nickel steel shaft.  
 Muffler.—As nearly silent as consistent with back pressure.  
 Steering.—Wheel irreversible.  
 Lighter.—Electric lamp lighter to light gas lights from seat.  
 Body.—Aluminum, side entrance, running boards, divided front seats, seating five persons.  
 Hood.—Aluminum, circular shape, instantly removable.  
 Weight.—2,000 pounds, scale weight.  
 Equipment.—Two oil side lamps, 2 by 8 inches, short focus lens, mirror headlights, set on car even with top of hood or a little higher; good horn, with screen; good generator with swinging basket, or gas tank; cravenette top; folding glass front; full tool equipment, with jack; tires equipped with tire treads, made from chrome leather, thick and heavy, with nickel corrugated rivets in the tread, round headed rivets on the sides to protect tires from ruts; fastened on the tires with steel wire rings through loops in the side of the treads.  
 The above car should give excellent service on our American roads, with a minimum amount of expense. The vibration and road shocks should affect the engine and other vital parts so slightly that the repairs should be very light. This car would be very easy on the tires. The long, full elliptic springs will make it very easy riding. This car should be marketed at \$2,250, f.o.b. factory, and would afford a fair profit at that figure.  
 Corsicana, Tex. CLARENCE THOMAS.

### WILL THE TIRE EXPERTS PLEASE ANSWER ?

Editor THE AUTOMOBILE:

[1,273.]—I have long been a close observer of the pneumatic tire problem, but this is the first time I have ever got up "in meetin'" to air my views. I am not going to bore you with any spring wheel or other fantastic and revolutionary cure-all for tire troubles on the pleasure automobile, as experience with the types in daily use, extending over several years, has convinced me beyond a doubt that there is only one tire, and that is the pneumatic. It is like gold—entirely in a class by itself, but just as we have "near-gold" and "like-gold," we have lots of "near" pneumatic tires, some of which look all right, but the majority of which are neither one thing nor the other, while all are merely more or less recent newcomers to the "just-as-good" class of substitutes.

However, what I would like to obtain some definite information on is the matter of the heating action of the pneumatic tire. It is a matter of common knowledge that running even a comparatively short distance at high speed generates a great amount of heat in a tire—so great that the bare hand cannot be borne on the shoe of the tire, even for a moment, and water thrown on the tires is partially converted into steam. A little consideration shows that there are several sources of this heat. Starting from the outside, these are: First, the friction between the shoe of the tire and the road, and probably this is much greater than is generally imagined; second, heat due to the side bending of the shoe and the working of its various plies, one upon another, this doubtless not being very great, as otherwise the tire would be apt to disintegrate very much sooner than experience shows to be the case; third, the friction between the inner tube and the fabric lining of the shoe, this doubtless also being a matter of minor importance, as if there were much relative movement between the two, the valve stem would soon be damaged; fourth, the continuous compression and expansion of the air in the tube, which is already under considerable pressure. If we have a five-inch tire inflated to 100 pounds to the square inch, this being the pressure to which it is subjected under the load of the car and passengers when standing, it must be evident that every blow which the tire receives in meeting obstructions, dropping into gullies and in otherwise overcoming obstacles, causes a reduction of its interior volume and a consequent rise in the pressure which is accompanied by the generation of heat. The causes of this super-compression, so to speak, follow one another with such

great rapidity when the car is running at high speed that the attendant expansion has but a slight cooling effect.

What I would like to find out is, whether the outside friction with the road, or this super-compression of the contained air, is responsible for the major portion of the heat generated in the tire, and if the latter be the chief cause, would it be of any benefit to interpose a heat-insulating substance between the inner tube and shoe, so as to confine the heat to the former? PNEUMATICS.

### CRITICISES DR. HARD'S IDEA OF COASTING.

Editor THE AUTOMOBILE:

[1,274.]—Dr. Hard, in his letter No. 1,229, seems to have a very hard time to tell whether the motor is pulling his car or the car pulling the motor, and if he is going up hill it is a question with him if it is advisable to use the high speed to gain power or the low speed. Compression is also a doubtful quantity with him. I quote, "when an automobile weighing 2,000 pounds descends a 25 per cent. grade, it is propelled by the force of gravity equal to one-fourth of its weight, plus the propelling force of its motor. The retarding forces to be overcome are total friction, air resistance, and the resistances to be overcome before the motor car delivers power. If the motor is turned by force applied to the drive wheels, these resistances remain constant, just the same as if the explosions overcame them. The faster the drive wheels turn the motor, the greater will be the resistance to be overcome and the slower the car will move. We will get the greatest service by using high gear with the spark throttle closed. Therefore, to coast down hill using the motor as a retarder, we should have a convenient circuit breaker and use the speed gear that gives the required resistance for steep hills, and intermediate or low for hills of less grade."

After all, the study of medicine does not make a man a mechanic. If the M.D. was to apply his medical skill to his patients as his letter would indicate he does his mechanical skill to his machine, his would be a good place for an undertaker.

Minneapolis, Minn.

JESSE JENNINGS.

### COMMENDING THE HAZLETON STEAMER.

Editor THE AUTOMOBILE:

[1,275.]—The letter by W. Hazleton on his steel-tired steamer was very interesting to me. We see little enough about steam automobiles in the papers these days, and this seems strange, because there are plenty of steam enthusiasts on deck, and the subject seems worthy of more attention.

The use of coal in an automobile has never, to my knowledge, been attempted, at least in a pleasure vehicle, and while this would result in economy it seems to me that this is not the place for coal. In regard to the evaporating capacity, Mr. Hazleton does not state whether this is based on evaporation alone from and at 212 degrees, or whether he means evaporating water as at the temperature fed to the boiler into steam, under the conditions which it leaves. If the latter, his boiler must have an efficiency of about 90 per cent., which would be very remarkable.

I think that Mr. Hazleton is mistaken in his statement that one pound of kerosene will evaporate 25 pounds of water. There is no question, however, but what the Hazleton type of boiler is very efficient and has great capacity.

New York.

GEO. F. WOOLSTON.

### BEST ROUTE FROM SPRINGFIELD TO ALBANY.

Editor THE AUTOMOBILE:

[1,276.]—Answering inquiry No. 1,214 for best route from Springfield to Albany: Via Westfield, Huntington, over "Jacob's Ladder," which, by the way, is only play for a good car, through East Lee, leaving State road just beyond at fork, direct to Stockbridge. Continue through West Stockbridge, State Line, East Chatham, Old Chatham, Malden Bridge, Nassau, Schodack Center (slow down for Judge Van Ness), Albany, 92 miles. Have made nineteen trips over this route, and find it the best. The direct Pittsburg-Albany road will be torn up this summer.

Albany, N. Y.

C. S. RANSOM.

### WHO CAN HELP OUT ON THIS?

Editor THE AUTOMOBILE:

[1,277.]—Last summer I drove a Ford runabout with which I repeatedly had the same trouble complained of by F. R. Zeigler in letter 1,217 of your issue of March 12, 1908. I note your reply to his query, but am very confident that in the case of the car to which I refer, the difficulty was not due to alteration of the needle adjustment by jolting or otherwise, while the car was running.

It may be that some others of your readers have had this same trouble and have succeeded in remedying it. If so, I trust one of them will be good enough to communicate with you on the subject.

New York City.

D.

## INDIANA'S AUTOING WEEK IS IN SUCCESSFUL PROGRESS

**I**NDIANAPOLIS, IND., March 25.—The second annual automobile show given by local dealers and manufacturers opened Monday. The largest automobile parade the city has ever seen took place to-day. The number of automobiles in line exceeded expectations, and a successful week is anticipated. There were four sections to the parade, which was headed by C. W. Newby, grand marshal, followed by Mayor Charles A. Bookwalter, members of the board of works, board of safety, the police automobiles and the Indianapolis military band riding on a big five-ton truck.

Following came one model each of the different cars handled by local dealers, each car bearing a card of uniform size with the name of the car, its price and the name and address of the dealer handling it in Indianapolis. The commercial vehicle section was a special feature, with trucks and delivery wagons ranging from a little Waltham-Orient to a big five-ton Pope-Waverly. Following this came scores of automobile owners, including individuals and clubs from all parts of Indiana.

Tuesday morning at 11 o'clock the hill-climbing contest was held at Michigan Hill, northeast of the city, and there were fifty contestants, including a special event for motor trucks and delivery wagons.

The obstacle race will be held Thursday afternoon on Capitol Avenue boulevard. The week closes with a dinner at the Grand Hotel Saturday night.

In order to carry out the events of the week successfully, the Indianapolis Automobile Trade Association was organized and incorporated last week, as a voluntary association, without capital stock. Frank Staley, of the H. T. Hearsey Vehicle Company, was elected president; A. E. Vinton, of the G & J Tire Company, vice-president; P. D. Stubbs, local representative of the American Motor Car Sales Company, and secretary of the Overland Automobile Company, secretary; Frank L. Moore, of the Fisher Automobile Company, treasurer, and B. W. Twyman, of the Gibson Automobile Company, Charles R. Newby, manager of the Capital Auto Company, R. H. Losey, of the Buick-Losey Company, D. B. Sullivan, of the D. B. Sullivan Auto Company, and Paul Smith, of the Indianapolis Motor Car Company, directors.

Each dealer will exhibit in his own garage during the week. Several automobile manufacturers from over the State have obtained space in different parts of the city in which to exhibit their cars, and the accessory dealers will show their goods in the hotels.

## BOSTON'S SHOW STARTED BOOM IN LOCAL TRADE

**B**OSTON, March 23.—That the much talked about success of the Boston show and the heavy business reported was not all due to imaginations unduly excited by the predominating red in the show building decorations has been indicated since the show was closed, and the exhibitors have been in the quieter atmosphere of their salesrooms. Instead of the reaction which commonly follows show week, and which leads the exhibitors, after footing up their expenses, to say that a show is an interruption of business and costs as much as it comes to, the Boston dealers are enthusiastic over the results which were obtained, and they are producing bunches of signed contracts and long lists of people to be followed up, which they obtained during the week in Mechanics' Building. It is estimated that \$500,000 worth of cars were sold, but these actual sales are as nothing to the business that was started and which the dealers expect to close within the next few weeks.

Very conclusive evidence that the show started a boom in the local trade may be obtained at the automobile department of the State Highway Commission. The week previous to the

show only 314 automobiles were registered, show week the total was 438, while during the week following the show the registrations reached a total of approximately 600 cars. Motor cycle registrations also took a jump. This increase shows only a part of the effect of the show, for many of the cars that were purchased, probably the larger part, will not be delivered for several weeks. During show week, sixteen new dealers were registered, and the past week eight more have taken out certificates. Since the first of January, when the law required that all motor vehicles should be registered, the Highway Commission has issued about 6,900 certificates for automobiles, 300 for motor cycles and 275 for dealers. Only 346 new private operators' licenses have been issued, but it was unnecessary to take out new licenses of this sort as the old ones held over. There have been issued since the first of January 231 new chauffeurs' licenses, and 460 have been renewed. Up to the middle of the month, when the returns from the automobile department were last tabulated, the commission had taken in more than \$40,000 from this source.

### NEW HAVEN'S SHOW PROVES SUCCESSFUL.

NEW HAVEN, CONN., March 25.—The largest automobile show ever held in this State was brought to a most successful close here to-night. The New Haven Automobile show opened a week ago last Wednesday night. Mayor Martin, of this city, President Fuller, of the Connecticut State Automobile Association, and Montague Roberts, who piloted the Thomas car the first leg of the New York-Paris race, were present. The exhibition was held in Music Hall, the largest auditorium in the city, which was beautifully decorated, the decorations including several novel electrical effects. Every auto dealer and agency in the entire city was represented at the show, there being a complete accessories exhibit in the basement of the building.

Aside from the big show, there was an annex exhibit of Maxwell and Stoddard-Dayton cars in a building only two doors from the main show.

The Yale Automobile Club successfully held its first annual banquet last Wednesday night at the University Club.

### DELAWARE TO HAVE ROAD SIGN BOARDS.

WILMINGTON, DEL., March 23.—Recently it was announced that the Delaware Automobile Association had decided to have sign boards placed at the road intersections in New Castle county, and now comes the announcement that the work will be done by the county, at the suggestion of Road Engineer James Wilson, who will supervise the project. In order to work in harmony in its efforts to insure the enforcement of the automobile law, the executive committee of the Delaware association has had a conference with the police commissioners.

### AUTOISTS ENDORSE GOOD ROADS ADVOCATE.

MILWAUKEE, WIS., March 23.—That the good roads question is liable to become a political issue in Wisconsin was demonstrated last week, when a number of Janesville autoists endorsed J. B. Brown for the State Senate. Brown will make good roads his whole platform, and, judging from reports from that place, he will have a walkover.

### FARMAN ECLIPSES ALL FLYING RECORDS.

PARIS, March 21.—Before a large gathering at the parade grounds of Issy-les-Moulineaux, Henry Farman to-day successfully accomplished the greatest feat that has ever been achieved in aeronautics. He made a continuous circular flight of two and a half kilometers, or about two miles, in 3:21, which is at the rate of 38 miles an hour. At least half of this time he sailed directly into the teeth of a stiff breeze, and that the latter did not perceptibly diminish the machine's speed is considered Farman's greatest triumph. The machine was of the heavier-than-air type of his own invention, and rose from the ground like a bird, without the slightest hitch, then circling around under perfect control at a height of about 30 feet. The course followed measured a mile, but the distance actually covered was easily twice this, as the inventor caused the machine to make long swerves one way and the other to show under what perfect control it was.

Yesterday Farman made a flight of two kilometers at a greater height and is confident that, within a year, machines will be made capable of flying fully 12 miles without coming to the ground. He also predicts that the sport will never become general, as it is not only costly, and real flying is too hard to learn.

Following his record-breaking performance, Farman accepted an invitation from Leon De La Grange to enter his machine, with which the latter had been making successful short flights throughout the day. De la Grange sent the machine over the ground at the rate of 30 miles an hour and then went into the air, succeeding in making a short flight. This is the first time on record that two persons have been aloft in an aeroplane of the heavier-than-air type.

### INTEREST ACTIVE IN BALLOON CUP RACE.

PARIS, March 21.—A. B. Lambert, secretary of the Aero Club of St. Louis, is here, his chief object being to awaken interest in the aeronautical contests to take place at St. Louis next Fall, when the club will distribute \$35,000 in prizes. He is also reported as stating that the St. Louis club is anxious to take over the International cup race again in the event that the German club is not able to make the necessary arrangements. The French club announces that there are so many desirous of representing France in this event that the choice of three contestants to go to Germany has had to be deferred. The club has recently received a concession of a large plot of ground at the Issy-les-Moulineaux parade and will shortly erect ten sheds for aeroplanes. The Spanish Aero Club has arranged an elaborate program for the season and will start it with a long-distance balloon flight, which will start from Barcelona on May 17. The prizes are 9,000, 4,000 and 1,500 pesetas for the first, second and third arrivals, respectively.

### CORRECTING THE STEARNS' 1908 DESCRIPTION.

In publishing a detailed description of the Stearns car for 1908, which appeared in the March 19 issue of THE AUTOMOBILE, on pages 401 and 402, a half-tone illustration foreign to the car was inadvertently inserted on page 402, and captioned "Bronze to Steel Emergency Brake and Its Housing." As a matter of fact, this was a photographic view of the new Le Moon rear wheel clutch, designed to do away with the differential, and its appearance in connection with the Stearns car was entirely out of place.

### L. E. FRENCH TO EDIT A. S. M. E. PUBLICATIONS.

The American Society of Mechanical Engineers is to be congratulated upon the acquisition of Lester E. French to head its editorial department. Mr. French has had a long technical and newspaper experience, having been for nine years past editor-in-chief of *Machinery*, besides having compiled numerous textbooks on technical subjects. So many improvements are planned in the society's editorial work that no progressive engineer can afford to miss its various publications.

## THE AUTOMOBILE CALENDAR.

### AMERICAN.

#### Shows and Meetings.

- Apr. 4-11.....—Pittsburgh, Pa., Duquesne Garden, Annual Show. Automobile Clubs of Pittsburgh. Thomas I. Cochran, manager.  
Apr. 5-12.....—Montreal, Canada, Arena, Third Annual Automobile and Sportsman's Show. R. M. Jaffray, Mgr.  
Apr. 6-8.....—Denver, Mammoth Rink, Annual Automobile Show. G. A. Wahlgreen, manager.  
Apr. 16-18.....—Memphis, Tenn., Automobile Show, Memphis Automobile Dealers' Association. William Bruce, secretary.

#### Race Meets, Hill Climbs, Etc.

- Apr. 6-10.....—New York City, Automobile Carnival, Illuminated Parade, Hill Climb, etc., New York Automobile Trade Association.  
Apr. 24.....—Briarcliff Trophy Race, Westchester County, N. Y. Robert L. Morrell, chairman.  
May 4-5.....—Harrisburg-Philadelphia and Return, 300-mile Endurance Run, Motor Club of Harrisburg.  
May 15.....—Chicago, Algonquin Hill Climb, Chicago Motor Club.  
May 16.....—Hartford, Conn., 200-mile Endurance Run, Automobile Club of Hartford.  
May 30.....—Bridgeport, Conn., Sport Hill Climb, Bridgeport Automobile Club.  
June 24-27.....—Chicago, 1,200-mile Reliability Run, Chicago Motor Club.  
July 6-8.....—Buffalo, National Convention of the A. A. A., and Start of Fifth Annual A. A. A. Tour.  
Sept. 14.....—Chicago, Annual Economy Run, Chicago Motor Club.

### FOREIGN.

#### Shows.

- Mar. 26-April 4.—London, Olympia Industrial Vehicle and Motor Boat Show.  
Mar. 28-April 6.—Paris, Alcazar d'Ete, Small Inventors' Exhibition.  
May 17-31.....—Austria, Budapest Automobile Show.  
May 17-June 2.—Moscow, Russia, International Automobile Exposition, Automobile Club of Moscow.  
December.....—Paris, Eleventh Annual Salon de l'Automobile, Grand Palais, Automobile Club of France.

#### Race Meets, Hill Climbs, Etc.

- April 1-13.....—Monaco Motor Boat Races and Motor Boat Exhibition, International Sporting Club of Monaco.  
April 25-May 25—Industrial Vehicle Competition, Automobile Club of France.  
May.....—Paris, Competition for Agricultural Automobiles, auspices of "L'Auto." (Date to be announced.)  
May 7.....—Sicily, Palermo, Targa Florio Circuit, Voiturette Race, Automobile Club of Italy.  
May 11-16.....—Ireland, Irish Reliability Trials.  
May 1-31.....—Automobile Taxicab Competition, France, Automobile Club of France.  
May 10.....—Sicily, Targa Florio, Automobile Club of Italy.  
May 31.....—Russia, St. Petersburg to Moscow Race.  
June 1-18.....—Reliability Trials for Pleasure Cars, Automobile Club of Great Britain.  
June 14.....—Mount Cenis Hill Climb, for Voiturettes.  
June 9-17.....—Touring Competition for the Prince Henry of Prussia Prize, Germany, Imperial Automobile Club of Germany.  
June 15-19.....—Scotland, Scottish Reliability Trials.  
July 6.....—Voiturette Grand Prix, Dieppe Circuit (Automobile Club of France).  
July 7.....—Grand Prix of Automobile Club of France, Dieppe Circuit.  
July 13-17.....—Ostend, Belgium, International Race Week, Automobile Club of Ostend.  
July 20-30.....—Ardennes Circuit Races and Coupe de Liedekerke, Automobile Club of Belgium.  
Aug.....—France, Coupe de la Presse, Automobile Club of France. (Exact date to be announced.)  
Aug. 29-30.....—France, Mont Ventoux Hill Climb, Vauclusien Automobile Club.  
Sept. 1-8.....—French Voiturette Contest, auspices of "L'Auto."  
Sept. 6.....—Bologne, Italy, Florio Cup Race, Automobile Club of Bologne.  
Oct. 11.....—Berlin, Germany, Gordon Bennett Balloon Race, Aeronautical Club of Berlin.

## CALIFORNIANS PREPARING FOR AN ACTIVE AUTOING SEASON

**SAN FRANCISCO, CAL.,** March 20.—For the first time in the history of automobiling on the Coast, an organization devoted to the sport has systematized a schedule of events and has issued a full program for the season, in advance. This is the Automobile Dealers' Association of California, and, judging from the ambitious sale on which it has outlined its program, there should be no dearth of interesting events. The dates and runs are as follows:

Monday, March 29, club run by members and their friends to the summit of Mt. Hamilton and return, leaving San Francisco on the 7 A. M. boat for Oakland, thence southward to San José, stopping at Smith's Creek for luncheon. Then the trip up the mountain and return to San José, going home on either side of the Bay.

Saturday, April 11, hill-climb in or near San Francisco. The cars will be classified as follows: Gasoline runabouts, \$1,500 and under, two passengers; touring cars, \$1,500 and under, four passengers; touring cars, \$2,000 and under, four passengers; runabouts, \$2,000 and under, two passengers; touring cars, \$2,500 and under, five passengers; runabouts, \$3,500 and under, five passengers; free-for-all, gasoline or steam, two or more passengers. The entry fee will be \$20, to be returned if the entrant starts.

Saturday and Sunday, May 30 and 31. Two-day endurance

run round the Bay. First day, by way of Mission road to Uncle Tom's Cabin, round Spring Valley water works' lakes, to Half-Moon Bay, to San Gregorio, La Honda, Redwood City, by way of the Summit to Mountain View, to Los Gatos by way of the Saratoga road, and to San José. Second day, to Mission San José, through Livermore, Concord and Walnut Creek, over the Fish Ranch grade to Berkeley and finish at Oakland.

Saturday, July 4. Two days' trip through Marin, Sonoma and Napa counties. This event may be postponed, should the Automobile Club of California plan one for the same time.

Sunday, and three days following, September 6, 7, 8 and 9. This stretch covers two holidays, Labor Day and Admission Day, and may be utilized for an extended endurance run to Los Angeles. Nelson's record for the distance of 520 miles is 18 hours 13 minutes, but 48 hours will be allowed for the run each way, with a day's rest at Los Angeles.

As a curtain raiser to the program the association, through its Runs and Tours Committee, will welcome the contestants in the New York-Paris run to the Golden Gate. A. B. Watson, chairman of the committee, will head a delegation that will go south as far as San José, and will assume the duties of piloting them to San Francisco, this task having been undertaken by the Santa Clara Automobile Club as far as San José. The local club is preparing to make a great deal of the event.

## A. M. C. M. A. NAMES ITS COMMITTEES FOR 1908

**COMMITTEES** for 1908 were announced last week by Benjamin Briscoe, chairman of the committee of management of the American Motor Car Manufacturers' Association. There are few changes in the committees over last year. The show committee, which is always an active one, will again have H. O. Smith, president of the Premier Motor Manufacturing Company, as its chairman. Associated with him will be S. H. Mora, of the Mora Motor Car Company, and R. M. Owen, of the Reo Motor Car Company. The following are the committees in full:

**Show.**—H. O. Smith, Premier Motor Mfg. Co., chairman; S. H. Mora, Mora Motor Car Co.; R. M. Owen, Reo Motor Car Co.

**Tours and Races.**—W. C. Marmon, Nordyke & Marmon Co., chairman; H. O. Smith, Premier Motor Mfg. Co.; A. C. Newby, National Motor Vehicle Co.

**Good Roads.**—Chas. E. Lewis, Jackson Automobile Co., chairman; James Couzens, Ford Motor Co.; R. E. Olds, Reo Motor Car Co.; H. B. Krenning, Dorris Motor Car Co.

**Legislation.**—R. E. Olds, Reo Motor Car Co., chairman; C. G. Stoddard, Dayton Motor Car Co.; A. C. Newby, National Motor Vehicle Co.; R. A. Palmer, Motorcar Co.; R. E. Graham, Acme Motor Car Co.

**Advertising and Publicity.**—Barney F. Everitt, Wayne Automobile Co., chairman; Harry Fosdick, Moon Motor Car Co.; G. B. Louder-

back, Buckeye Mfg. Co.; Theo. P. Bailey, St. Louis Car Co.; Leon Myron Bradley, New York office; Charles E. Duryea, New York office.

**Membership.**—W. H. VanDervoort, Moline Automobile Co., chairman; Morris Grabowsky, Rapid Motor Vehicle Co.; R. E. Burroughs, Abendroth & Root Mfg. Co.

**Finance.**—James Couzens, Ford Motor Co., chairman; W. G. Morse, Atlas Motor Car Co.; J. B. Bartholomew, The Bartholomew Co.

**Standardization and Technical.**—John D. Maxwell, Maxwell-Briscoe Motor Co., chairman; Henry Ford, Ford Motor Co.; R. S. Crawford, Crawford Automobile Co.; L. P. Mooers, Moon Motor Car Co.; R. E. Olds, Reo Motor Car Co.

**Freight and Transportation.**—Harry Knox, Atlas Motor Car Co., chairman; H. W. Mack, Mack Bros. Motor Car Co.; R. Harry Croninger, Pennsylvania Auto-Motor Co.; J. N. Willys, Overland Auto Co.; G. D. Wilcox, Gearless Transmission Co.; C. C. Hanch, Nordyke & Marmon Co.

**Tires.**—G. V. Rogers, Mitchell Motor Car Co., chairman; James Couzens, Ford Motor Co.; Frank Briscoe, Brush Runabout Co.; O. Stevenson, York Motor Car Co.

**Agencies.**—W. H. VanDervoort, Moline Automobile Co., chairman; A. R. Welch, Welch Motor Car Co.; H. S. Leyman, DeLuxe Motor Car Co.; Frank L. Pierce, Gaeth Automobile Co.; H. B. Larzelere, Chadwick Engineering Works.

## NEW JERSEY'S AUTO AGENTS BEGIN ATTACK ON POLITICIANS

**NEWARK, N. J.,** March 23.—That no stone is to be left unturned to rout the politicians who have been making auto legislation to suit themselves is evident from the first move in the campaign undertaken by the New Jersey Automobile and Motor Club and the New Jersey Automobile Trade Association, who are acting in conjunction. To demonstrate to the public the value of the automobile industry to the State of New Jersey, the Trade Association is sending broadcast to manufacturers a request to state from what makers in Jersey they buy parts of various kinds. The circular letter is signed by Secretary Ellis and President Paddock, of the association, and outlines the reasons for this particular move. It is, in part, as follows:

"Our politicians are blind to the extent to which our State is benefited by the automobile and the great number of people who

depend on it for a livelihood, for the reason that they do not see a complete car made here, but the fact is that New Jersey, more than any other state, benefits by the automobile.

"1.—From the fact that almost every part entering into its construction is made by our factories, including forgings, castings, bearings, springs, tires, lamps, bodies, varnish, leather, paint, electrical appliances, wire, tools, jacks, machinery, wheels, axles, gas tanks, trunks, radiators, gears, etc.

"2.—The peculiar location of our State makes it most attractive for tourists, and great amounts of money are annually left with our hotels, summer resorts, garages and merchants generally, and the automobile has immeasurably benefitted the real estate business and brought more desirable residents to the State than anything except the railroads.

"We are going to fight and fight hard. We will make it a paramount political issue with us and will look to parties rather than to persons for results."



### ADVANCE OF THE CARRIAGE-MAKERS' ART.

Ever since the time, three or four years ago, when the carriage-maker first awoke with a start to the possibilities of the automobile and its future, there has been a keen rivalry on the part of different makers to see who could bring forth the most artistic and completely furnished closed body. As a result, many closed cars have come to represent a standard of

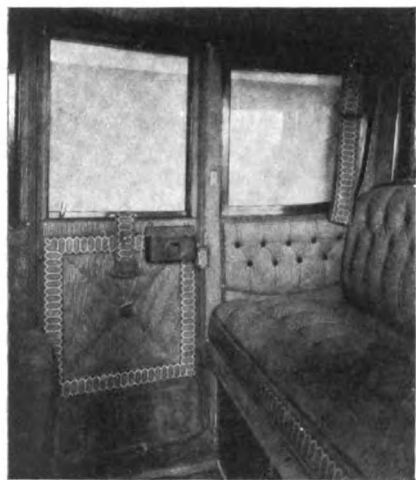

Interior Finish of Franklin Coupé.

taste and equipment far in advance of anything that had been thought possible in connection with body-building on the horse-drawn vehicle. A good example of this refinement of interior finish that forms one of the striking developments of the industry during the past few years, is represented by the accompanying photograph of a special four-passenger Franklin coupé.

This is finished in striped buff, French whipcord with lace to match, the broad lace around the door and front edge of the seats being designed especially to harmonize with the whipcord cloth. Quite a unique effect has been produced by lining the ceiling of the car, which carries a neat dome electric light, with the same pattern of cloth used on the remainder of the interior. The curtains are of light brown French silk and the carpet of French wilton, all harmonizing in the general buff color scheme, which is extended even to include the handles, these being made of brownish-yellow horn. The windows are all arranged to drop in pockets, and have frames of polished mahogany. The car is very roomy, and is said to be one of the best of its kind ever turned out by the Franklin Company, which has only turned its attention to the closed vehicle within the past two years.

### NEW MODEL LOCOMOBILE ON VIEW.

One of the new models unveiled at the recent Boston show is the Locomobile roadster shown by the accompanying photograph. The chassis resembles the Locomobile, "Type 40," in most particulars, but the springs have been made lighter, owing to the reduced weight of the body employed, while the low seats give the car a lower appearance than it ordinarily has.

The designers have taken particular pains to secure a combination of style, conservatism and comfort, as it has been noticeable that many cars of this type are extremes,

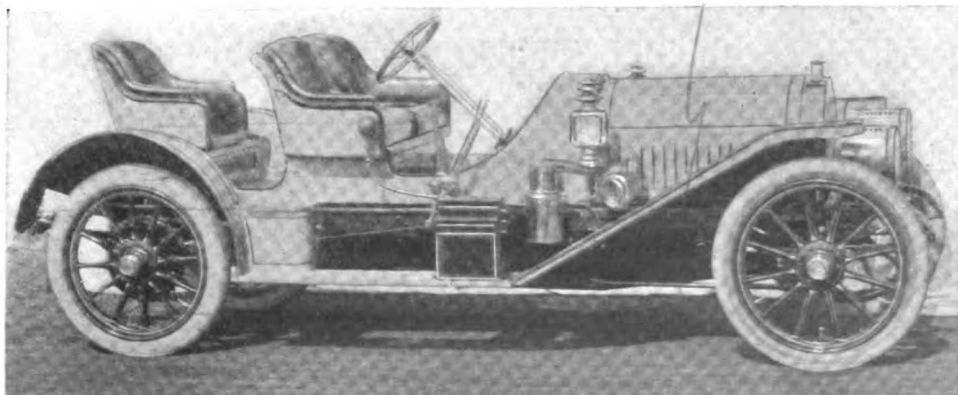

First Roadster Type of the Locomobile Turned Out from the Bridgeport Factory.

some even having the driver's seat almost over the rear axle, so that the seats are far from comfortable.

In this Locomobile "40 runabout" the seats are large and comfortable, and the seating capacity is variable, the two rear seats being placed on an artillery tool box. One of these seats may be removed, and the other placed on the center of the box, thus making it a three-seated car, or both of these seats may be removed. There is ample space between the box and the back of the front seats to carry a good-sized trunk or hamper, or the box itself may be removed, leaving the platform free. Some of these cars have already been placed, and the makers are planning for April deliveries.

### STRIVING FOR RAMBLER CLUB PRESIDENCY.

KENOSHA, WIS., March 23.—Competition is keen for the presidency of the recently formed Rambler Fifteen Thousand Mile Club, every member of which must have covered at least 15,000 miles in a Rambler car. Major Edwin S. Muir, of the city of Winona, Minn., a formidable candidate for presidency, has a record of 20,000 miles from one Rambler car, 18,000 from another, and 6,000 from a third. Joseph I. Bennett, Boston, is a strong second with 19,000 miles from one car, the first 5,000 of which were traveled with an expenditure of but 85 cents for repairs. From the letters received from owners desiring membership in the club, it is shown that the average cost is a little more than two cents a mile, many owners having run forty to fifty thousand miles at a cost of less than \$200, exclusive of tires. Oil and gasoline averages one cent a mile, and repairs make up the remainder. Thomas B. Jeffery & Company offer a handsome watch fob as a membership token and as an incentive to owners to send in facts about the cost of keeping their cars. One hundred members are now enrolled in twenty-six different States. According to recent registration returns, 10 per cent. of the 2,211 automobiles in Nebraska are Ramblers; Illinois possesses 738 Ramblers out of a total of 9,799 cars, and Wisconsin claims 477 cars from the Thomas B. Jeffery factory among the 3,852 in daily use in that State.



### ENTRY BLANKS READY FOR HARRISBURG RUN.

HARRISBURG, PA., March 23.—Rules for the second annual endurance run of the Motor Club of Harrisburg, to be held May 4-5, were issued to-day. This year's run will be over 300 miles in length, and will have the night control established at Philadelphia. On the first day, 168 miles will be traversed by the contestants via Lebanon, Reading, Allentown, Easton, Doylestown to Philadelphia. On the return trip, the mileage will be 145 miles, via Norristown, Reading, Lancaster, Columbia, Marietta, Mount Joy to Harrisburg.

There will be four classes in the run, as follows: Class A, for touring cars costing \$2,250 and over; Class B, for touring cars costing less than \$2,250; Class C, for runabouts costing \$2,000 and over; Class D, for runabouts costing less than \$2,000. Handsome silver loving cups will be awarded as prizes in each class to the winning cars.

**ELIMINATING THE DIFFERENTIAL.**

Ever since automobiles have come into practical use, attempts have been made to do away with the balance gear, or differential, which has been found necessary to enable the car to take turns and to save the wear on the tire of the wheel which takes the inside of the curve. One of the latest of these is known as the Le Moon axle, the chief feature of which is that it transmits the

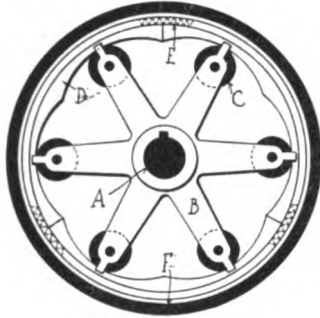

power through the slow-turning wheel alone when rounding a curve. It consists of a special form of automatic clutch applied to each rear wheel, one of these clutches being illustrated in elevation and section by the accompanying illustration.

These clutches consist of a spider *B* keyed to the driveshaft *A* of the axle. The end of each star piece carries a roller *C*, which bears upon an arc segment *C* of an expander *D*, which expander is forced outwards against the drum *F* on the rear wheel, thereby locking the axle *A* to the road wheel. The expander *D* is made in three sections, with springs *E* separating them, these springs serving to disengage when the clutch releases. The spoke of the wheel is designated *W*, and the wheel, loose on the driveshaft *A*, is only connected thereto when the expander *D* engages with the drum *F*. The driveshaft *A* extends from end to end of each axle and carries

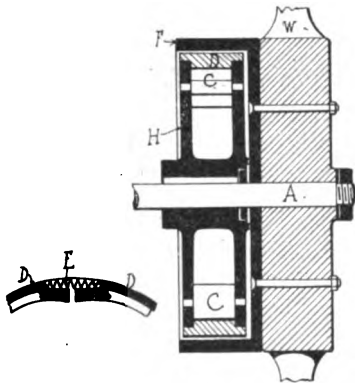

Elevation and Sectional Views of Le Moon Clutch In Place.

a spider *B* on each end. Whether going straight or turning corners the axle and both spiders revolve at the same speed. When driving on the straightaway, the rollers *C* in their efforts to revolve, attempt to climb the curvature of the arc of the expander *D*, thereby expanding *D* and locking it to the wheel and rotating it. Should a corner have to be turned, the outer wheel is compelled to travel faster than the spider *B*, and so runs away, as it were, with the expander *D* until the rollers *C* are in the middle of the arc, at which point there is no engagement between the clutch *D* and the drum *F*, and then the inside wheel is carrying the car around the corner. When the corner is rounded and the road wheels run at the same speed, the clutch operates and the drive through both wheels is resumed. The claim that this device reduces skidding is based on the fact that the inner wheel drives when turning the corner.

According to the inventor, Mr. Le Moon, where a car starts turning to the left, if the outer wheel does the driving, its tendency is to keep moving in a straight line, irrespective of the turn made by the front wheels, and this tendency to drive in a straight course, results in the skidding. When the inner wheel drives, it also tends to follow the straight line or direction the car was following before the turn, but the direction of its effort is practically through the center of the car. Inventor Le Moon attaches great importance to this feature and claims remarkable freedom from slipping on cars equipped with his clutches. Dr. J. R. Pennington, 103 State street, Chicago, who is exploiting the merits of the invention, claims to have given some most satisfactory exhibitions of its work, and is confident that the Le Moon can be employed most satisfactorily as a substitute for the differential balance gear now universally employed. This would tend to both simplify and strengthen rear-axle construction to a very great extent.

**PACKARD NEGOTIATING FOR E. V. CO. PLANT.**

HARTFORD, CONN., March 23.—Though none of the terms of the deal are forthcoming, nor is it definitely settled that it will be consummated, it is known that the Packard Company is negotiating for the purchase of the Electric Vehicle Company's plant in this city. This much the officials representing the Packard interests, H. B. Joy and M. J. Budlong, are willing to admit. The hopelessly entangled condition of the defunct company's affairs is given as the reason for the delay that is bound to ensue before it will be announced definitely whether the plant will be taken over or not. In the meantime, it is currently reported that the purchase has practically been completed and that the only thing remaining is to settle the details.

It is rumored that M. J. Budlong, formerly president of the Electric Vehicle Company, will take charge of the Hartford works when they pass under Packard control, and that the plant will be used for the manufacture of commercial cars and taxicabs. What will become of the Selden patent, and whether it is included in the sale as an asset, is a matter for much speculation. It still has four years to run and, should it be upheld by the courts, its value will be tremendous.

**TWO STUDEBAKERS FOR THE A. A. A. TOUR.**

It has been formally announced by C. F. Reddin, of the Studebaker Bros. Company, New York City, that at least two Studebaker cars will be entered in the A. A. A. Glidden tour. "The consensus of opinion," says Mr. Reddin, "seems to favor an endurance test of some kind, and the Glidden tour is, perhaps, the most satisfactory solution of the problem. Unquestionably, some of the faults which developed in the rules of the 1906-07 tours will, from experience, be eliminated in the tour of the coming season. Whatever the rules are, it is now my intention to enter at least two of our cars, and I feel certain that they will make as good a showing as they have in every contest in which we have entered."

**AMERICAN TAXICABS BECOMING NUMEROUS.**

Interest in the solution of the cab problem on the part of American manufacturers is growing apace to judge from the number of new cars designed for this service that are making their appearance on the market. The latest of these to be brought out is the Oakland, of which a photograph is shown here. It is being produced by the Oakland Motor Car Company, of Pontiac, Mich., and is the work of Alanson B. Brush. It is the first of its kind to be placed on the market at such a low price, as it lists at \$1,850 in complete running order, as shown. It is of extremely light, yet stanch, construction and has been designed particularly with a view to economical running and maintenance; in other words, as a dividend-earner.

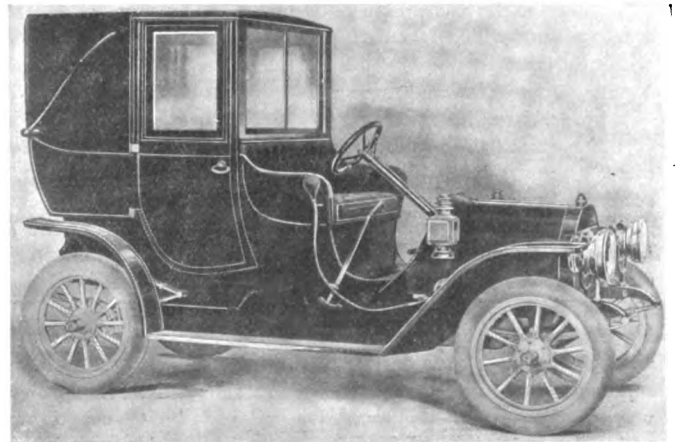

Attractive Lines of the New Oakland Taxicab.

### HOWARD NOW MARKETS ASSEMBLED CAR.

Since adopting its plan of selling the complete parts for six-cylinder and four-cylinder cars, which was described in these columns some time ago, the Howard Motor Works, Yonkers, N. Y., find that there are a great many prospective purchasers who doubt whether the assemblage of parts thus supplied "will go together or not." They have accordingly decided to modify their plan of marketing these materials to the extent of giving

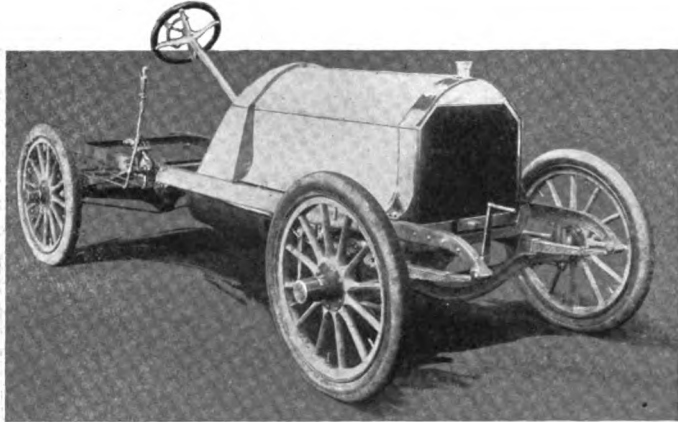

Complete Assembly of Howard Six-cylinder Parts.

the purchaser the option of taking the car in pieces, or completely assembled and ready for the body as shown in the accompanying illustration, which shows one of the six-cylinder type. These cars are equipped with the well-known Howard four- and six-cylinder, four-cycle, vertical, water-cooled motors, which are designed and constructed according to the best engineering standards. They are equipped throughout with the best grade of accessories, such as the Hill Precision oiler, and have numerous special features of construction, such as the Delahaye type of slip joint on both the water piping and inlet manifold.

The clutch is of the conical type, with cork inserts and the change speed gear provides three forward speeds and reverse on the selective plan of operation, the clutch and gear being inter-connected by means of an ingenious and positive interlocking device which prevents the shifting of the gears until the clutch is disengaged. Final drive is by propeller shaft to a live rear axle. The six-cylinder car is geared 2.5 to 1 on the high speed, while the four-cylinder car is geared 3 to 1. The complete parts of the six-cylinder car, including tires, list at \$1,200, or \$1,500 assembled as shown, while two-seated bodies may be had from \$100 upward. The touring car lists at \$1,100 and \$1,400 respectively and will accommodate a five-passenger touring body.

### HUNTING ANTELOPE IN AN AUTOMOBILE.

"Although it is some time ago now, doubtless the story of the antelope hunt which I made in my car last fall will be of considerable interest to you," writes M. L. Woodman, of Lewistown, Mont., to the National Motor Vehicle Company, Indianapolis. "However, I will confine myself to a bare statement of the facts," continues Mr. Woodman, "leaving all literary embellishments to yourselves, that being, if my information is correct, an accomplishment with which every Indianian is gifted.

"Accompanied by an expert chauffeur, Johnny Warner, we left Lewistown, where I reside, about 8 o'clock in the morning of October 10 last, and set out in my National for the foothills of the Belt Mountains, located in Meagher County, Montana. Lying about twenty miles northwest of Harlowtown and sixty-five miles from this city is a spring where I was sure we could find some antelope. The roads were superb and we let her out on the way over, covering the sixty-five miles without even a pause and making the distance in an even two hours. Upon arriving at the spring we drove around for a few minutes until, with the aid of a powerful field glass, I located a bunch of about twenty-

five antelope lying down at a distance of about five miles.

"We headed the machine in that direction and succeeded in getting within one mile of the antelope before they jumped up, ready for the race. The country is of a rolling nature that has been close-cropped by thousands of sheep, so that we could make out all holes and stones some distance ahead. The antelope broke into a run when we were within about three-quarters of a mile of them. We started after them at a moderate pace to get some idea of their speed, gradually creeping up. After following half a mile or so in the rear for a short time, we let the machine out and the way we began to close the gap made it appear as if the animals were standing still. After running about two miles we came within fifty feet of them. Going at a 35-mile an hour rate, I brought down one of them and then took the wheel while Warner handled the gun and brought down another.

"We dressed the antelope, loaded them on the car and started for home, arriving back in Lewistown in the afternoon, having traveled fully 150 miles in the short time we were out. This was my first hunt for big game in an automobile, but it is my intention to repeat the experience next year, having fully convinced myself that my National can easily outrun even an antelope, which is one of the fleetest animals to be found on the plains."

### IMPROVED WHEELS FOR PORTABLE TANKS.

Wire wheels not having proved satisfactory on their special portable gasoline tanks, owing to their continually catching on projecting parts of the cars, and wood wheels not being practical, S. F. Bowser & Company, Fort Wayne, Ind., have adopted the indestructible steel wheels made by the Indestructible Steel Wheel Company, 1304 Michigan Boulevard, Chicago. These wheels are very light for their size and are extremely strong. As is the case with the pleasure type for automobile use, the steel stampings are perforated, as will be noted on reference to the accompanying illustration of a Bowser portable tank equipped in this manner. The makers of the indestructible wheel are now perfecting a type for motor-cycle use, which will be placed on the market in the near future, as these wheels are especially adapted for service calling for extreme strength and a minimum weight.



Bowser Garage Tank with Indestructible Steel Wheels.

**IMPROVING CARBURETER AIR REGULATION.**

Doubtless the question of automatically altering the amount of air supplied to the mixture provided by a carbureter has been by far the most puzzling that the maker of a carbureter has had to contend with. Certain it is that it has been the subject of a greater number of inventions and patents than probably all the other parts of the carbureter put together. One of the most

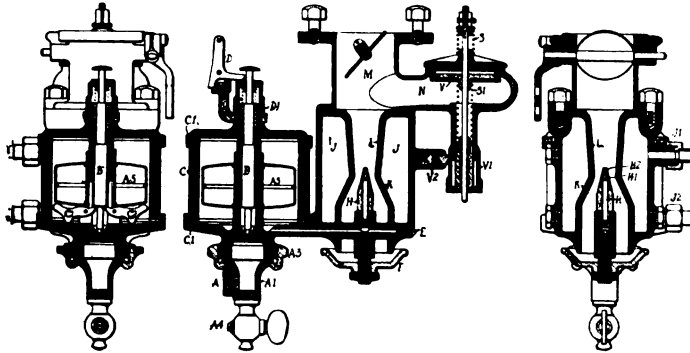

Sectional Views of the New Goldberg Carbureter.

recent attempts to solve the problem and one that has met with unusual success, is the Goldberg carbureter, made by the Goldberg Motor Car Devices Manufacturing Company, 1253 Michigan avenue, Chicago. It is the result of more than two years' close study of the subject on the part of its inventor, although it has now been on the market but half a year.

The chief features of its design will be apparent from the accompanying sectional illustration, which shows it to be of the float type, the gasoline entering from below at the point *A*, this being a universal type of coupling permitting the end *A'* to be turned in any direction. Departing from the usual practice of making the interior of the float chamber a closed book, it has been made of Macbeth glass 1-4 inch thick, which is claimed to be practically unbreakable. This glass chamber rests on combination rubber and cork washers *C*<sup>1</sup>, so that by screwing the cover down tightly on its central support it is made perfectly gasoline tight. The needle valve *B* is purposely made of heavy and durable construction. It is operated by the two triangular-shaped levers *C*<sup>2</sup>, formed with toe-pieces resting against a shoulder on the valve and the high heel parts on which the drawn brass float *A*<sup>3</sup>, rests. The valve *B*, is held on its seat by the spring *D*<sup>1</sup>.

Another feature in which the Goldberg carbureter differs is in the nozzle, which is not provided with any means of adjustment, but has openings of three different diameters, the largest, *H*<sup>1</sup>, being near the top, while one of medium diameter is a short distance above it, this being shown at *H*<sup>2</sup>, and the smallest, *H*<sup>3</sup>, is in the tip of the nozzle. The exterior of the cone, *H*, bears a definite relation to the conical sides of the chamber *K*, which is such as to produce a strong current of air at low speeds, the auxiliary air inlet meanwhile remaining closed. The gasoline level is 5-16 inch below the top of the cone, or approximately at the bottom of the smallest opening. The mixing chamber is water-jacketed and an unusually large amount of water used, as is indicated by the size of the spaces *J*, thus insuring against condensation even in the coldest weather, while should this occur higher up, as at *M*, the liquid will fall back into the heated zone. The thimble, *F*, at the base of the chamber, regulates the size of the normal air opening, and when starting any overflow from *H* falls into *F* and is there vaporized on the principle of the surface carbureter.

The spring-controlled auxiliary air-valve, *V*, takes care of this essential, which is controlled by a high-speed spring, *S*, and a low-speed spring, *S*<sup>1</sup>, the latter giving an opening of 1-64 to 1-32 inch, while the former permits the maximum opening of the valve, one coming into action as the other stops, *S*<sup>1</sup> acting alone on the low speed, the relative tension of these springs hav-

ing been carefully worked out. The Goldberg is made in 1, 1 1-4 and 1 1-2-inch sizes, the various parts being exactly proportioned in each case, so that a carbureter of this make when purchased for a motor of a certain size may be said to be accurately adaptable to it, as if designed expressly with its needs in mind, and with the present demands for greater economy and efficiency this is what is required in every instance.

**SIMPLIFYING THE GLASS WINDSHIELD.**

One of the most important developments in the design of that essential that few drivers care to be without for any length of time—the windshield—has been the elimination of the array of bolts, nuts and fasteners which had to be manipulated every time an adjustment was necessary. This was a distinguishing feature of the early types of glass windshields, and the culmination of its development toward the other extreme, that of simplicity, is to be found in the new Williams divided windshield, now being placed on the market by the Twentieth Century Motor Car Company, South Bend, Ind. It is so constructed that the top sash can be placed in any one of three positions without touching a nut, thumbscrew or bolt. The operation is accomplished with the aid of a simple locking device, the design of which will be clear at a glance at the accompanying illustration, showing it in longitudinal section.

One of these locking devices is placed at each side of the frame, and by taking hold of them and pulling down and outward, the sash may be moved to any position desired. The forward position leaves a space through which the driver can see the road very plainly, but still serves as a protection against rain and snow, while in summer it acts as a dust and bug shield though giving ample ventilation. The design and construction of the brass frame type of shield made by this firm is shown in the larger illustration. These fittings are machined throughout, all parts being made on jigs and templates, thus making them all interchangeable. On both the brass and the mahogany frames they are assembled with "anti-rattlers," which prevent them from becoming noisy. The wood frames are made in two styles, for touring cars and runabouts. On the brass frame there is not a nut or bolt to hinder cleaning, which will be found a great advantage.

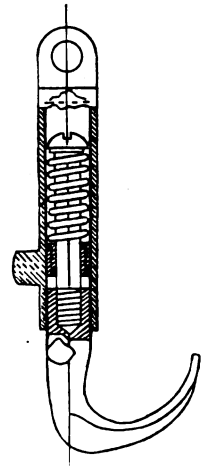

Automatic Hook of Williams Shield.

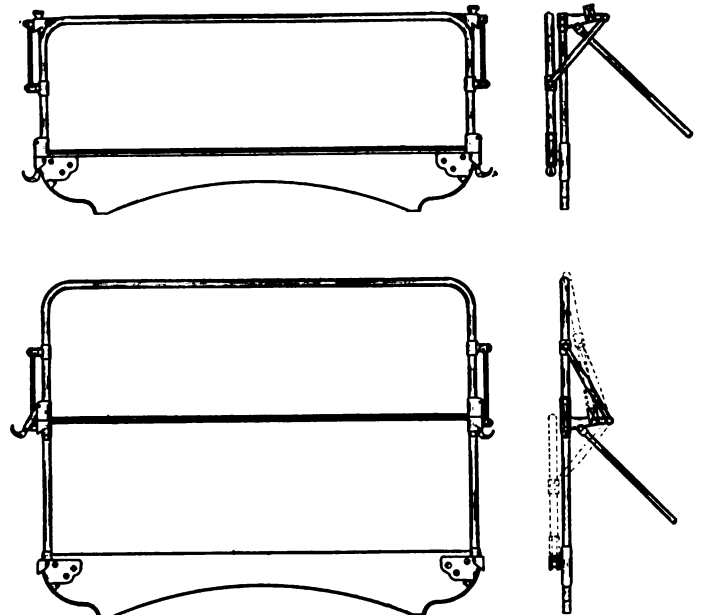

Showing the Williams Divided Windshield, Open and Closed.



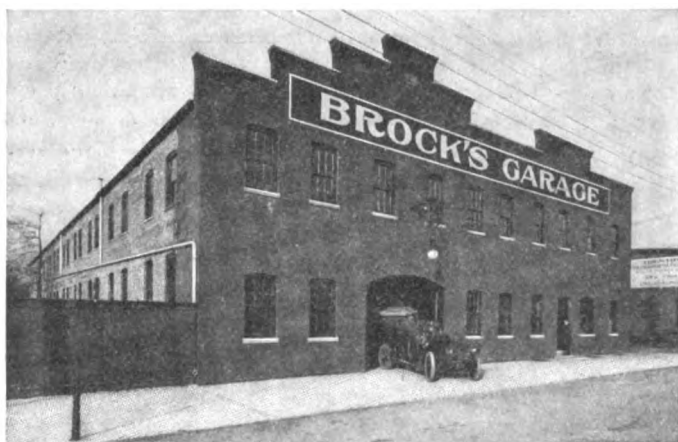

Showing the Extent of Trenton's (N. J.) Big Garage.

## THINGS DOING AMONG THE GARAGES.

### System Essential in Automobile Garage Business.

ROCHESTER, N. Y., March 23.—As many an experimenter has learned to his cost, the automobile garage business, by reason of its many ramifications, is one in which it is easy to lose money. A reliable system of bookkeeping and consistency in carrying it through are in every case essential to success. The United States Automobile Company, of this city, has evolved a system which appears to keep a very close check on all departments and to preclude possibility of waste of time or material.

As far as customers are concerned the charges are the usual ones for live and dead storage. The internal working embodies the use of a time clock for all arrivals and departures of men, cars, liveries, etc. The same system applies to the workshop, where every man must account for each half-hour of his time, besides reporting to the garage foreman if he is employed in the shop. Such general terms as "cleaning up," "shop work," etc., are unknown. For all accessories delivered a signed receipt is demanded, thus obviating any later claim that goods were not delivered. In connection with this is the usual system of receiving goods through a receiving clerk.

Just what it costs each day to run the garage is shown by a special daily form, giving the exact amount paid in and paid out in connection with the establishment. The bookkeeping system comprises about twenty-five different headings, with a debit and credit account for each, thus keeping an absolutely correct distribution of payments and earnings in all the different departments into which a garage business can be divided.

### New Jersey's Capital Has a Fine New Garage.

TRENTON, N. J., March 23.—Quite a notable addition to this city's garage facilities—in fact to that of the State of New Jersey—was made last fall in the shape of the new Brock garage, located on Canal street, just off East State street and near the Pennsylvania railroad freight depot. Its owner is John L. Brock, who has had a number of years' experience in the business, and who planned the building throughout with a view to handling the largest number of cars without confusion. The building is of brick construction, two stories high, and measures 80 feet front by 154 feet in depth. The first floor is devoted to storage, making it easy to run cars in and out of the garage at short notice. An independent locker is provided on this floor for each one of the cars stored there. Access to the second floor is by means of an electric elevator which conveys cars to the repair shop and electrical department. Both of the latter are of the most modern type throughout, the repair shop being completely equipped with the latest improved machinery, all of which is motor driven, while the electrical department affords facilities for the charging of a number of cars simultaneously and has a storage capacity for 60 cars. A

special reception room is provided for women, and every provision has been made both for the ready handling of the car, as well as the comfort of the drivers. The establishment represents an outlay of \$25,000 and is reputed to be one of the largest and best equipped of its kind in the State. Mr. Brock is the Trenton representative of several well-known cars, and also carries a full line of accessories. He is a member of the contracting firm of Prior & Brock.

### An Imposing New York Up-State Garage.

GLENS FALLS, N. Y., March 23.—Nothing is so strongly indicative of the permanent nature of the automobile business in the smaller cities of upper New York State as the imposing character of the buildings that are being put up within the last year or two for garage purposes, as well as the amount of money that has been spent on facilities for the comfort of the automobile owners who look to these establishments for the storage of their cars, as well as their supplies.

The Miller Brothers Garage, located at 12 Maple street, in this city, forms a typical example of this, and some idea of the size of the establishment may be gained from the accompanying reproduction from a photograph. The building is two stories in height, of fireproof construction throughout, and with its wide front and ample depth affords storage and washing facilities for a large number of cars. The building is devoted exclusively to garage purposes, the office of the proprietors being situated at 7 Bay street. As Glens Falls is located right at the entrance to the Adirondacks and lies between Saratoga and Lake George, the number of tourists that pass through it daily during the season is unusually large, and the demand for garage accommodation and facilities is correspondingly large. This accounts, to a certain extent, for the size of the Miller Brothers' establishment, though there are quite a number of cars of various makes owned by local residents in the city and suburbs.

### Delaware City's Garage Facilities Growing.

WILMINGTON, DEL., March 23.—The T. C. Bradford Company, which conducts a large automobile, motorboat, bicycle and general sporting goods establishment at 711 Market street, will shortly undertake the establishment of an up-to-date automobile garage which will represent a welcome addition to the city's facilities in this respect. The large Tanguy stable property, located at Tenth and Tatnall streets, has already been leased for ten years and the work of remodeling the former dwelling place of the equine motor into a modern automobile garage will shortly be undertaken. Every modern facility will be installed and the establishment will be a model of its kind when completed. The lessees will take possession this week.



The Garage that Glens Falls, N. Y., Is Proud of.

## FORT GEORGE HILL-CLIMB TO BE FROM STANDING START

FOR the first time in the history of events of its class in this country, the Fort George hill-climb, New York City, which will be run off on Thursday, April 9, as one of the features of the auto carnival to be given under the auspices of the New York Automobile Trade Association, will be made from a standing start. This is done for two reasons, probably the chief of which is the danger of a flying start, owing to the obstructions in the shape of the pillars of the elevated structure at that point, and on which one of the contestants came to grief last Summer. It is also a much more severe test of a motor's power and will not be a great disadvantage, as a short run will be available before taking the grade. No alterations on stock cars will be permitted, other than that of gears and the removal of mufflers, tops and windshields.

Since first issuing the program of this event, the hill-climb committee of the association has revised the classification of the different entrants so that they now stand as given below, the chief changes being the addition of two open classes in which steam and gasoline cars may compete together, beside special classes for steam and electric cars. The list of events will be:

- 1.—Gasoline cars selling for \$850, or less.
- 2.—Gasoline cars selling from \$851 to, and including, \$1,250.
- 3.—Gasoline cars selling from \$1,251 to, and including, \$2,000.
- 4.—Gasoline cars selling from \$2,001 to, and including, \$3,000.
- 5.—Steam, gasoline or electric cars selling from \$2,001 to \$3,000.
- 6.—Gasoline cars selling from \$3,000 to, and including, \$4,000.
- 7.—Four-cylinder cars selling for more than \$4,000.
- 8.—Six-cylinder cars selling for more than \$4,000.
- 9.—Free-for-all, open to cars of all motive powers.
- 10.—Open to steam cars only.
- 11.—Open to electric of all types.

Entry fee for each car for each event, \$10.

Early entries for the carnival parade, to be held on the evening of Tuesday, April 7, include 50 Oldsmobiles, 25 Maxwells, 6 Stearns and 6 Studebakers, the other entries already bringing the total over 200, although the blanks have only been out a short time. Several entries of floats have already been made for the dealers' division, prominent among them being one of Jones speedometers and one of P. & H. tires.

The search for the oldest car still in use has brought forth a two-cylinder, six-horsepower Panhard imported in 1898. It will be driven by George Robertson and will be given the post of honor, unless something antedating it should be unearthed in the interim. It has been decided to start the parade at 7:30 in the evening from Broadway and Fifty-seventh street, the route being as already given in THE AUTOMOBILE. The reviewing stand will probably be located on Broadway at or near Eighty-sixth street.

### THIRD ANNUAL HILL-CLIMB AT BRIDGEPORT.

BRIDGEPORT, CONN., March 23.—Preparations are well begun for the third annual hill-climb of the Bridgeport Automobile Club, at Sport Hill, Easton, on the morning of May 30. Chairman Ralph M. Sperry, of the contest committee, has obtained permission from the selectmen of Easton to use the road on the hill on the morning of Memorial Day, and during the present week a meeting of the committee will be held and the classes arranged. A. H. Crawford, of New York, who won the Yale cup last year, has expressed his intention of offering a special prize cup. A. L. Riker, of the A. A. A. racing board, has been asked to officiate as referee.

### QUAKER CITY M. C. ROADABILITY CONTEST.

PHILADELPHIA, March 23.—On Saturday, April 11, the Quaker City Motor Club will run off the second event of its season's program—a "roadability" contest from Philadelphia to Cape May. The winner will have to be an excellent judge of pace, for drivers will have absolutely nothing to go on except the speedometer. The chief emblem, the handsome \$500 silver Hotel Cape May cup, will go to the car that most nearly approaches the official schedule time figured out for the course by the officials.

Time allowances will be secret, each driver carrying a sealed envelope, which will not be opened until the finish is reached, when the start and finish times will be compared and the relative positions of the contestants figured out. Second and third cars will be awarded certificates of merit, while the drivers will receive medals. The event will be open both to club members and outsiders, the latter "coming up double" on the entrance fee.

### POWELL EVANS HEADS A. C. OF PHILADELPHIA.

PHILADELPHIA, March 23.—Powell Evans has been elected president of the Automobile Club of Philadelphia, to serve during the year 1908-09. The other officers elected are: Vice-president, Stedman Bent, and S. Boyer Davis, secretary and counsel. The new board of governors will be made up of Stedman Bent, S. Boyer Davis, George B. Linnard and Isaac Starr, who will serve for one year, and Henry P. Baily, Powell Evans and Jacob J. Seeds, whose terms will expire in March, 1910.

### A. C. A. ESTABLISHES SUPPLY DEPARTMENT.

With a view to affording its members reduced prices, the Automobile Club of America has added a supply department, located on the third floor of the clubhouse, and will handle a complete line of tires and accessories.

### NEW YORK MAY HAVE F. A. M. NATIONAL MEET.

In response to a call sent out by Henry Wehman, secretary of the Federation of American Motorcyclists, there was an enthusiastic gathering at the Grand Union Hotel on Monday evening last. The outcome of the meeting was the formation of the Federation of American Motorcyclists 1908 Meet Club, which was organized for the purpose of conducting the next annual meet. Toledo, O., was an applicant for the event, and the only one outside of New York. As the sentiment in favor of holding the affair here is very strong, there seems to be little doubt that New York will be decided upon. The dates are to be fixed by mail, and will not be announced for a fortnight or more.

The officers of the newly organized club are: President, R. G. Betts; vice-president, L. H. Gutermann; secretary, Henry J. Wehman; treasurer, David Dessau. Both President Betts and Secretary Wehman hold the same relative positions in the national governing body.

### PROVIDENCE COMPANY GETS TAXICAB ORDER.

It has been known for some time that the William H. Seach Company, of New York, which has the cab privileges of the Waldorf, Holland House and the Park Avenue hotels, was in the market for taxicab equipment to take care of these stands, and it has been rumored from time to time that the order for them had been placed with various companies. It is now known definitely that an initial order for 100 cars has been placed with the American Locomotive Automobile Company, Providence, R. I. Two of the latter company's make have been plying in New York streets experimentally for several months past, and they won out against the entire field of both foreign and domestic types. No details are forthcoming as to the design of this smaller brother of the American Locomotive auto, but it is presumed that it will be found a most representative type of its class.

## BRIEF ITEMS OF NEWS AND TRADE MISCELLANY

The West-Stillman Motor Car Company, Philadelphia, agents for the Pennsylvania and Mercedes, have secured the agency for the Atlas car in the same territory.

Charles A. Bebbler, Jr., formerly a partner in the North Side Vulcanizing Company, has just branched out for himself, establishing headquarters at 331 Michigan avenue, Chicago, where he will carry on a general tire repair business, dealing in all makes of tires and accessories.

Dating from March 16, the firm of Robert Bosch, New York, Inc., has been changed to the Bosch Magneto Company, in order to more clearly identify the name of the company's products in the public mind. The change is wholly one of title, and is merely for the reason indicated.

Pirelli & Company, the Italian tire manufacturers, who have an American branch house at 296 Broadway, New York, have just issued a revised price list on their tires, which went into effect on March 15. This concern is the oldest manufacturer of rubber goods in Italy, and has a most complete equipment of modern machinery for tire making.

Louis Strang's work on the Isotta-Fraschini at Savannah, on Thursday last, was a Michelin victory as well, for which Strang was awarded \$200 in cash, as his car was equipped with the Michelin compressed tread tires. This is the second victory for Michelins, as Bernin's Renault, which made a world's record at Ormond, was similarly equipped.

Memphis (Tenn.) automobile dealers have just formed a trade association, under the title of the Memphis Automobile Dealers' Association, of which Jerome P. Parker is president, and William Bruce, secretary. Arrangements have been completed for an automobile show, to be held on April 16, 17 and 18, next, the building having 30,000 square feet of floor space.

One of "Pal's" latest industrial works of art is the Continental Caoutchouc Company's poster advertising the Continental "Rouge Ferre" tires. It consists of a female figure surmounting one of the tires of the type in question, and as it is executed in brilliant colors, the effect is striking and unique. It is looked upon as one of the best specimens of this artist's poster work.

The Palmer & Singer Manufacturing Company, New York City, has just received its first consignment of Selden cars. The new car is a 30-horsepower, five-passenger touring type, and is universally considered one of the best of its kind ever offered at such a low selling price, namely, \$2,000. It follows standard engineering practise throughout, and is very well built, bearing no resemblance to the "original" Selden.

The Hartford Suspension Company has just been granted an injunction against the Motor Car Equipment Company, New York, agents of the Hercules Auto Specialty Manufacturing Company, of Los Angeles, Cal., restraining them from making or selling the Hercules shock absorber, which the Hartford company claims is an infringement of the well-known Hartford-Truffault device, covered by patents.

When it comes to original and attractive forms of advertising literature, Colo-

nel Sprague, of umbrella fame, who has made Norwalk, O., one of the best known cities in the country, ranks with the top-liners. His latest takes the form of a pair of calendars that will be honored with a place on the wall after their value as such has departed. They are entitled a "Bold Bluff" and "A Waterloo," and show groups of dogs playing poker, and are handsomely lithographed.

The rumor that the Winton company would market an eight-cylinder car next season is untrue. The success of the Six-Teen-Six has justified Mr. Winton's enthusiasm as to sixes, which to his mind, are infinitely superior not only to fours, but also to eights. The racing car, *Bullet No. 2*, had eight cylinders, and although this car was highly successful, Mr. Winton asserts, it is not to be compared for an instant with the Six-Teen-Six.

✓ Motor car shipments for the second week in March amounting to more than twice as much as the shipments for the first week of the month are reported by the H. H. Franklin Mfg. Co., of Syracuse, N. Y. Twenty carloads of automobiles were sent out during the week to points widely distributed throughout the country. Orders were well in advance of those for the preceding week. The Los Angeles dealer wired in for two carloads, and urgent orders for carload shipments were received from other Pacific Coast points.

"We have already received orders for 500 more cars than our agency contracts call for," says R. E. Olds, of the Reo Motor Car Company, Lansing, Mich., "despite the fact that the majority of these contracts were made as early as last September, when there was no suspicion of a financial slump. Confronted with these conditions, we have been compelled to increase our facilities for the production of 1908 models of the Reo cars, although we now have 1,100 men who have been working all winter, the Reo plant having been worked to its full capacity right through."

The Chicago Motor Car Company, which sells Packards in Chicago, figures out the question, "What becomes of all the automobiles that have been used for several seasons," thusly: These figures show that of 100 per cent. of the Chicago owners of 1908 cars, 91 per cent. of the owners of 1907 cars, 82 per cent. of the owners of 1906 cars, 80 per cent. of the owners of 1905 cars, and 50 per cent. of the owners of 1904 Packard cars, still drive their original cars. For a period of five years, 95 per cent. of all purchasers of Packards are still driving them, 87 per cent. retaining their originally purchased cars, and 8 per cent. having purchased later models of the Packard. Of the remaining 5 per cent. 2 1-2 per cent. are now driving other makes, while 2 1-2 per cent. have none.

English automobile papers have been devoting a great deal of space and attention to the recently concluded "standardization" test which was carried out with the aid of three single-cylinder Cadillac cars. The conditions were that these cars be totally dismantled, their parts being placed in three heaps. The Royal Automobile Club's technical committee then intermingled the parts promiscuously, and from the lot it was the duty of the Cadillac mechanics to reassemble three complete machines. This was done at the

garage of the Anglo-American Motor Car Company, London, agents for the Cadillac in England. After being reassembled, the cars underwent a long and strenuous test on the Brooklands race track, proving in a striking manner the accuracy of American methods of multiple production as exemplified by a car of which thousands have been turned out.

At the recent Buffalo show, the local Aetna Insurance Company agents, Knoll & Turgeon, who make quite a specialty of automobile insurance, had engaged a very prominent space, when they were confronted with the regulations that "no signs, and no advertising placards would be allowed." They were in a quandary as to how to "get their money's worth," as they had no mechanical devices to exhibit, but the difficulty was solved by mounting on a small box a toy circular saw and a toy trip hammer, operated by belts made of elastic bands, the power being supplied by a small motor. The sharp, insistent and rapid tap-tap-tap of the hammer drew the crowd, and the onlooker's gaze passing to the mechanical toys rested on a neat placard behind them, reading "We will keep right on hammering and sawing wood until we get your automobile, accident and health, and liability business," which effectively told the story.

### NEW AGENCIES ESTABLISHED.

The Continental Caoutchouc Company, makers of the Continental tires, have taken on a new representative in Buffalo, N. Y., their distributing agents in that territory from now on being the Centaur Motor Company, 59 Franklin street.

The Ranger-Barrett Auto Company, Minneapolis, Minn., has taken the agency for the Glide line of cars for that city and St. Paul. This arrangement was concluded during the recent visit of R. A. Whitney, general sales manager of the Bartholomew Company to that city.

On April 1, the White Company will open a large branch house in Pittsburg, having secured the building at 138-148 Beatty street, formerly occupied by the Liberty Auto Company. W. B. Yoder will be in charge. This is the eighth White branch, and it will cover Western Pennsylvania.

R. E. Graham, of the Acme Motor Car Company, Reading, Pa., is making an extended trip through the West visiting the company's different agencies. In Chicago arrangements have been made with Webb Jay & Co., to handle the Acme line. Mr. Jay intends to enter the Acme in all events in the West to which the car is eligible.

### PERSONAL TRADE MENTION.

Edward B. Lausier has resigned as sales manager of the motor department of the American & British Mfg. Co., Bridgeport, Conn., to accept an important position with the Timken Roller Bearing Axle Company, of Canton, O.

John C. Spiers, formerly factory manager of the Autocar Company, Ardmore, Pa., has just gone with the Standard Roller Bearing Company, Philadelphia, and will take full charge of the latter concern's manufacturing department.

INFORMATION FOR AUTO USERS

**Duplex Carbureter.**—No matter how superior the design and workmanship of a motor, or the material used in its construction, the service rendered will not be very great unless it is equipped with a satisfactory form of carbureting device. The converse is true, in that many a very ordinary engine could be vastly improved

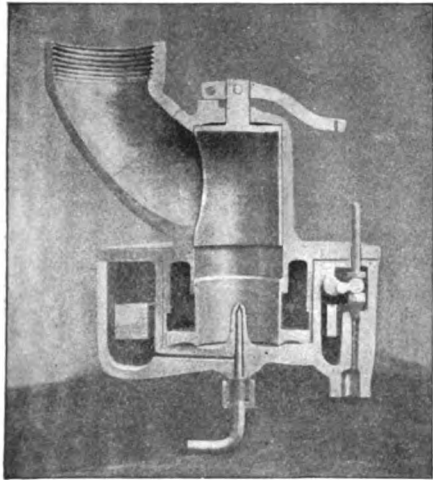

SECTION OF THE DUPLEX CARBURETER.

by putting a good carbureter on it. The Duplex Roller Bushing Company, Belfast, Me., in their extended experience in building motor boats, some of them very fast, have had an excellent opportunity to study the problem of carburetion, and in the "Duplex," are confident that they have evolved something which fills the bill. Simplicity and reliability have been the chief aims, and following them out has resulted in a carbureter without springs or auxiliary valves. It is of the concentric float type, and has but one adjustment and one throttle, as will be seen by the accompanying sectional view illustrating the Duplex carbureter in its entirety. No provision has been made for priming, as it has been found to be totally unnecessary with this new type.

**Quick-Acting Grease Gun.**—Miller & Starr, 250 Green street, Brooklyn, N. Y., are placing on the market a special type of grease filler known as the Miller "Quick-Acting" grease gun, designed for replenishing the change-speed gears and shaft bearings on automobiles and motor boats. The Miller grease gun is made of the best bronze and consists of a barrel with a nozzle at one end and a cap at the other, the plunger having its shank extended through the cap, the shank itself being provided with spiral grooves. Spiral lugs in

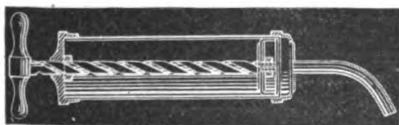

MILLER & STARR'S QUICK-ACTING GREASE-GUN.

the cap engage these grooves to reciprocate the plunger as the shank is rotated. The plunger is advanced rapidly and with a uniform movement by turning the handle shown, only four revolutions being necessary, so that the makers claim that this gun will empty a charge of eight ounces of grease in three seconds. It can be as quickly recharged by unscrewing the cap,

and its construction obviates the tedious process of unscrewing the plunger. The lubricant can also be ejected in exactly the quantity desired by turning the handle. Moreover, it will not spill nor lose its contents through the jolting of the car.

**Salisbury Wheels.**—In the mind of the autoist, "wheels is wheels," and provided they do their duty uncomplainingly there is probably no one part of the car that receives so little attention as the wheels. But that there are wheels and wheels is amply evident from the catalogue of the Salisbury Wheel & Manufacturing Company, Jamestown, N. Y. The hub is the vital part of any wheel, and as it is strong or weak, the wheel itself must be likewise.



DETAILS OF THE SALISBURY WHEEL AND HUB.

It is on this account that the makers of the Salisbury wheels dwell particularly on their patent Improved Artillery hub. This is made in two parts of malleable material, the inside flanges of each half being ribbed as shown. These ribs serve to stiffen the flanges, prevent torsion, keep the bolts from shearing off, and maintain the spokes in the proper alignment, from which it will be apparent that their advantages are more numerous than would appear at first sight. This company makes wheels of this type in all sizes, from those designed for the lightest runabout up to the heaviest car, turning out special sizes and patterns to order.

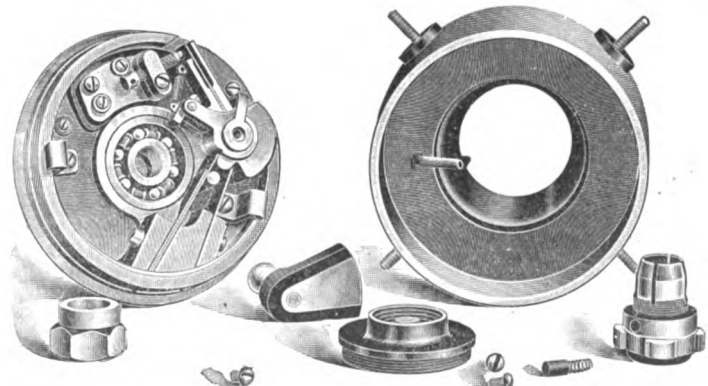

SHOWING THE PITTSFIELD SPARK COIL COMPANY'S NEW ACME IGNITER.

**Flentje Shock Absorber.**—This is a new device of the hydraulic type, employing glycerine as the operating fluid, and on which patents have been applied for. As will be apparent from the illustration, it is of extremely simple design and construction, consisting of a piston and cylinder, the latter adapted to be attached



FLENTJE GLYCERINE SHOCK ABSORBER.

to the axle of the car by means of a special bracket, while the former is made fast to the frame. The best grades of steel and phosphor bronze are used in its construction, all parts being heavily coppered and nickel-plated. The piston is pierced with six ports, allowing the glycerine to pass freely on the downward stroke, but partly closing automatically, thus checking the rebound by only permitting the fluid to pass slowly. It is being manufactured and marketed by Ernst Flentje, 1643 Cambridge street, Cambridge, Mass.

**Pittsfield Acme Igniter.**—This is a new combined contact maker, timer and distributor just brought out by the Pittsfield Spark Coil Company, Dalton, Mass., in response to the demand for greater economy and reliability in ignition systems us-

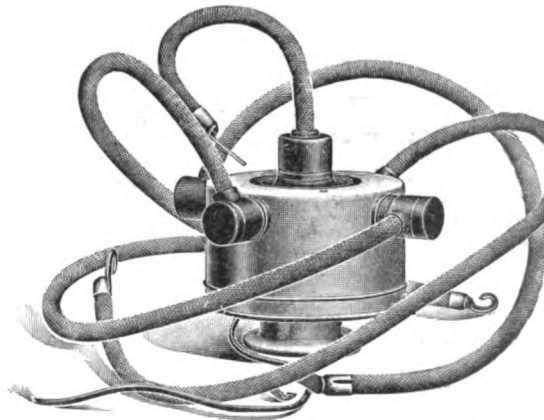

EXTERIOR VIEW OF NEW ACME IGNITER.

ing batteries, and particularly dry cells, as the source of current. It is, in short, a synchronous timing system in itself, as with the addition of a single vibrating coil it is adaptable to a motor having any number of cylinders. Its increased economy



is due to the fact that contact is made mechanically, so that it is always positive, regardless of the speed of the motor or the condition of the batteries, while it also eliminates the possibility of having the contacts "freeze" together. The contacts are insured long life as the circuit make and break is provided with a magnetic "blow-out," which prevents arcing and keeps the single large platinum contact cool. As will be evident from the accompanying illustration showing the Pittsfield Acme Igniter dismantled, it consists of but a few simple parts, and as its only moving member runs on an annular ball bearing, its life is practically indefinite. No changes are required to adapt it to the average car, as it is designed to be attached to the half-time shaft usually provided for the ordinary ignition timer.

**Emergency "Mud Hooks."**—This is a novel and ingenious device which has just been brought out by the Garage Equipment Company, Milwaukee, Wis., and is being placed on the market in the East by the Post & Lester Company, Hartford, Conn. It is intended for emergency use on occasions which occur so frequently on American roads—that of being hub-deep in mud, snow or sand. The makers guaran-

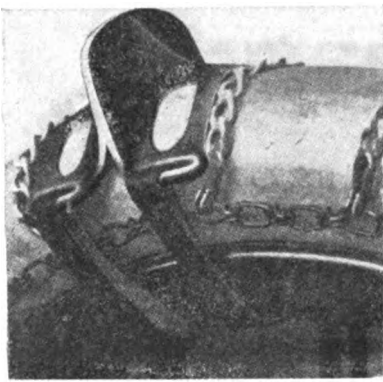

SHOWING THE EMERGENCY "MUD-HOOK."

tee one set of them to be sufficient to enable the car to pull itself out of bad places in which any one of these obnoxious materials happens to be the retarding element, and once the car is out they can be removed again. As the makers say, "The farmer will charge the price of two sets to pull you out of one hole." For long stretches of mud or deep sand two or three sets can be used to advantage. They are made of malleable iron, weighing 5 pounds per pair and can be applied to any tire from 3½ to 5½ inches. They are supplied either with or without straps.

**Invincible Schacht.**—One of the handy buggyabout type of cars that has forged quickly to the front is the Invincible Schacht, made by the Schacht Manufacturing Company, Cincinnati, O. It was one of the first of its kind to be seen at the Boston Show recently, and attracted far more attention than did many of the high-powered and high-priced cars, as the down-Easters had heard a great deal of it, but had never seen this truly middle Western type of automobile. It is distinguished by numerous features of design and construction, employing no gears or clutches. A friction type of transmission is used, the flywheel disc of the engine being brought into contact with the driving wheel on the main countershaft by means of a pedal. Any speed from one to thirty miles an

hour can be attained by shifting the hand lever at the side of the body, and this can be operated at any time, regardless of the speed that the car happens to be traveling at. The long Concord springs and high-cushion tired wheels of second-growth hickory were familiar sights to the New Englanders, but they had never seen them



THE "INVINCIBLE" SCHACHT RUNABOUT.

combined with an automobile power-plant before. It is equipped throughout with roller-bearings, and its general appearance is quite a pleasing contrast to that of many of the high-wheelers. Its makers have been building automobiles for a number of years, so that it represents the culmination of a long experience in this line. Many agencies have been placed in different parts of the country this Spring.

**Improved Tire Casings.**—Unprotected casings, though they may never be called upon to do any work, deteriorate so rapidly that it is rare for an automobilist to carry them on his car without some cover. From the earliest types, in which the tire was protected by a rough canvas cover secured by buttons, various improvements have been made, until now pneumatic tires are as carefully gloved as a lady's hand. One of the latest types of casing, patents for which have been issued to H. R. Teele, is marketed by Hopewell Brothers, Cambridge, Mass. Instead of the buttons or laces usually employed, the duck or leather

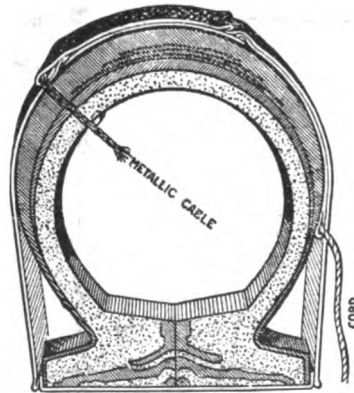

SECTIONAL VIEW OF THE TEELE COVER.

casing is attached by means of a metallic casing at one end and a cord at the other. As will be seen from the sectional view, the inner diameter of the tire case does not pass over the outside diameter of the tire; consequently the inner portion of the tire case makes a perfect fit to the tire, avoiding the customary wrinkled appearance.

**The Scientific Carbureter.**—This is a new type of carbureter that is the invention of E. W. Stevens, East New Market, Md., and is the result of three years'

constant study of the problem of carburetion, supplemented by exhaustive experiments. The "Scientific" carbureter is not of the float feed type, as will be evident from the accompanying sectional view of Model A, designed for two-cycle motors. Probably a description of its method of operation will suffice to make matters clearer than merely describing its construction. The fuel enters at *A* and is strained by *C*, then passing the needle valve *D*. The plate *J* is pierced by four triangular openings coinciding with ports, and is moved by *K* to open them more or less as needed. The valve *D* is threaded into the piece *Y*, and at its outer end carries a pinion meshing with a rack carried by *J*, so that moving the latter causes *D* to open more or less as the throttle is moved, so that the amount of fuel used is always in proportion to the air admitted. The draught through the mixing chamber causes the wheel *N* to revolve at

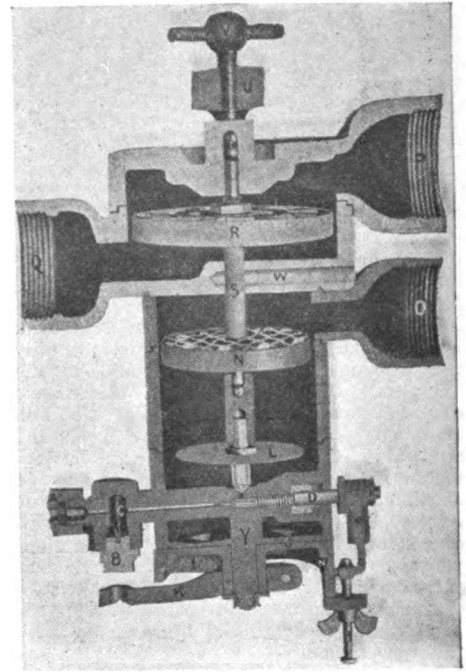

DETAILS OF THE "SCIENTIFIC" CARBURETER.

high speed, thus increasing the suction on the opening of the inlet valve of the motor, causing the valve *L* to lift and admit a predetermined amount of fuel which is thoroughly mixed with the air by the revolving wheel and being blown against the hot plate of the member *Q*, and issuing at *O*. The exhaust from the engine enters at *P*, sets the wheel *R* spinning, and as the latter retains its momentum it greatly increases the scavenging of the engine. The "Scientific" carbureter is being manufactured in both two and four-cycle types by the E. W. Stevens Company, East New Market, Md.

**Brampton Auto Chains.**—Charles E. Miller, 97-101 Reade street, New York City, has just received a large shipment of the well-known Brampton English chains and is now in a position to supply all calls for both American and foreign standard sizes. Mr. Miller has been importing these chains for a number of years, during which time the demand for them has increased to a very great extent, as they are their own best advertisement.

# THE AUTOMOBILE

## AMERICAN LEADER NOW ON ITS WAY TO ALASKA

SEATTLE, WASH., March 31.—If it had not been for the seventy cars lined up on the steamship pier, waiting to act as a special escort to the Thomas, it would have seemed as if the American leader in the Paris-New York race were the first and only automobile that the inhabitants of this city had ever had an opportunity to see. Nothing brought home so strikingly to the observer the fact that the West is taking the event with the greatest interest, as the reception that the Thomas crew received on its arrival here. It was one thing for San Francisco to go wild over the Thomas, because it rolled into that city's midst right over the road it had been traveling for almost 4,000 miles, whereas here the car was hoisted out of the hold of the steamer *City of Pueblo*.

But that made no difference to the huge crowds that assembled along the waterfront two hours before the steamer was due. As soon as the tires touched the dock and the chain slings were removed the car was mobbed by autograph cranks, who wished to scribble their names all over it, so that it was some

time before the crew could get near enough to start. To do so, they had to shake hands with every one who could get close enough. Finally the Thomas, with Schuester at the wheel, led the procession through the streets, which were so packed that traffic was completely demoralized for the time being. After the parade, the Thomas was taken to a garage to be given a final rubdown before being shipped on the *Santa Clara*, which leaves for Valdez, Alaska, to-morrow. Similar scenes of enthusiasm were enacted on the occasion of the car's departure, and the Thomas, with its crew, received a truly Western send-off and God-speed on their long journey. The *Santa Clara* is due at Valdez on April 6.

Seattle is the chief winter resort of Alaskans, and men who know the country that the cars will have to traverse are here in plenty at this time of the year. Their opinions of how far the Thomas will get out of Valdez would hardly be called encouraging, and are remarkable for the unanimity, only differing slightly on the mileage question. Many are quite certain that one



The Thomas Globe Girdler Among the Current Creek Mountains, Utah, Where the Sage Brush Is Luxuriant.



Crossing a Rocky Ditch Where Differential Broke.

mile will mark the end of the journey, while it is conceded that ten miles out of Valdez will be a world's record. Charles H. Hamilton came from Fairbanks to Valdez early in February, over the same trail that the Thomas is to take, and is probably best qualified to speak. "There's no crust on Alaska snow," he says, "and it won't hold a man except on snowshoes, and the trail, or so-called post-road, is only 42 inches wide, while 10 miles beyond Valdez is Keystone cañon, where the trail narrows to 30 inches, so what is your 56-inch wide automobile going to do? Outside of the trail is nothing but snow, anywhere from 6 to 26 feet deep. At times the Delta river has three or four feet of water over the ice even in the coldest weather, so that you can't depend upon that."

#### Zust Enthusiastically Received at Los Angeles.

LOS ANGELES, CAL., March 31.—Upon their arrival here last night, the Italian crew were fairly mobbed by their countrymen, who showered them with oranges and flowers, and tried to drown them in champagne. The official welcome was tendered by Consul Giacomini and a large delegation from the Italian Club. From Cajen Pass, 70 miles out, where they were met by Capt. S. C. Ryus, the run was made in good time until within a few miles of the city, when a stump burst the gasoline tank. They were able to reach here without assistance, despite the accident, and ran the car to the White garage for repairs.

The De Dion reached Tonopah to-day, where it was met by a special reception committee from Goldfield, and requested to make its entry into the latter place in the afternoon. The Frenchmen complied, and found that a reception and ball had been prepared in their honor. The De Dion crew has been making up for lost time, as the 250 miles of desert from Ely to Tonopah were made in 13 hours, or a day and a half less than the Thomas required. The Protos is struggling between Granger and Evanston, Wyo., and is having a very much harder time of it than the other cars, owing to the recent thaws.



Indians at White River, Nev., Interested in Car.

### A STATEMENT FROM THOMAS COMPANY.

From the E. R. Thomas Motor Company comes this emphatic statement, signed by its president:

While many competitors are fair and realize our victory benefits the whole American industry, certain knockers, to boost their sales and injure ours, have made false and malicious statements that the Thomas Flyer was not a stock car, that cylinders were changed, and that the car was necessarily rebuilt during the race. We hereby notify them that their statements are false and malicious and must cease, or they will be prosecuted to the fullest extent of the law. We make the following statement in order that our friends and the public may know the truth, and we offer \$1,000 reward for proof to the contrary:

We hereby certify that the Thomas Flyer in the New York-to-Paris race is absolutely an ordinary stock car, selected only six days before the race, and was not specially prepared or tested. Furthermore, it is identical in motor, clutch, driving shaft, radiator, carbureter, transmission gears, frame, wheels, bearings, and in all other essential features of its mechanism now in use by Thomas owners.

We also certify that the Thomas Flyer ran from New York to Cheyenne, a distance of 2,028 miles, almost entirely over roads made practically impassable by snow and mud, climbing mountains, plunging through ruts, and fording streams without overheating once; without repair or replacements of cylinders, spark plugs, transmission, radiator, bearings, clutch, carbureter, or other mechanical parts. In fact, the only breakage was two chain links, easily replaced, and a sprocket housing.

Detailed reports beyond have not been received, but telegraphic reports state repairs were insignificant and that the car arrived in



Starting Out from Tonopah, the Miners' Paradise.

San Francisco in splendid condition, ready to proceed on the long journey, a feat unparalleled in the history of automobiles—the longest and severest endurance contest in the history of the world, and one that makes the Glidden tour on well traveled roads, between large cities, pale into insignificance by comparison. The Thomas was only entered because we believed it to be a reflection on the American industry to have five foreign cars carry five foreign flags across the American continent without an American car contesting for American supremacy.

(Signed) E. R. THOMAS MOTOR COMPANY,  
By EDWIN ROSS THOMAS, President.

### A. C. C. OF N. J. ELECT POST PRESIDENT

TRENTON, N. J., March 31.—The annual meeting of the board of directors of the Associated Automobile Clubs of New Jersey was held here this afternoon. Wilbur F. Sadler, Jr., of this city, declined another term as president, and George A. Post, of Paterson, was elected to succeed him. Other officers chosen were: W. C. Crosby, Newark, first vice-president; Walter E. Edge, Atlantic City, second vice-president; H. A. Bonnell, Newark, secretary and treasurer. The report of President Sadler showed that during the past year the membership of the association had doubled. The directors passed a resolution indorsing a bill introduced in Congress providing for the erection of a bridge over Newark Bay, and a bill pending in the Legislature which authorizes Freeholders to issue bonds for the repair and betterment of roads.



Thomas Coming Round the Turn Near Corinne, Utah.



Crossing a Mountain Range In Nevada.

**HOW MONTAGUE ROBERTS TOLD HIS STORY.**

**A**T the recent banquet of the Yale Automobile Club, held at New Haven, Montague Roberts was one of the guests.

"I can tell you a few things about the price of teams, and pancakes, and how it feels to be scared to death by a cowpuncher," he began. "That trip to Cheyenne was a pretty tough one, but the Harry S. Houpt company and I were too patriotic to allow any race to be run off without an American car being represented, and so when the Thomas was entered I agreed to pilot it.

"The time for me to run the machine was limited to four weeks, on account of my engagement at Briarcliff and in the Grand Prix races. After the Briarcliff races—if I don't kill myself—I shall start for France, and later take the American racer again in Siberia.

"Well, after we left New York, the snow wasn't so bad until we got to Albany. There we had to take the Erie towpath to Syracuse, where we again took to the roads as far as Buffalo. I've had dealings with farmers—I was born in Pittsburg myself—but never such dealings as I had from Buffalo on. We bucked the snowdrifts straight through to Toledo, and from there on—well, I never thought there was as much snow in the skies. Just beyond Toledo we put the car up in the village livery stable and went into a little country store to warm up. I started to wrestle with one of the boys to get my blood circulating and accidentally put my elbow through a showcase. Then the lady put me out. All the fellows followed, and we struck out for the next town. Honestly, it took us 14 hours to go 17 miles the next day, and then I was arrested for cutting down a wire fence and forced to pay \$15 in settlement. In the next town we landed in more snow, and it cost \$102 to hire four more teams to haul us out.

"In one place where we were stuck, we hired a 12-horse sled and hauled the car up on it. The car slid off into a ditch and pulled two horses in with it. It took three hours to get the car and horses out again, and some warm arguments with the teamsters regarding the cost followed. We ran the next 23 miles over the railroad ties. It wasn't so bad bumping the rails; but those thundering 'frogs' gave us a great time as we drew near Chicago. In Chicago we put on a new set of tires. It took the next two days to run 190 miles and we ruined the set. In northern Iowa the 'gumbo' mud, as they call it there, averaged anywhere from two inches to a foot deep all the while. Honestly, you'd have to help the car down hill at full speed. The sandy hills of Nebraska came next. There are no roads there—just a lot of ranches. I always had a longing to see a real cowpuncher. I've had a horse of my own, and now I've got a pair of those pants with the fuzz all down the side of 'em. They were given me by the Cheyenne Auto Club.

"Well, I met a cowpuncher near there. We were driving along at dusk, when I heard the sound of horse's hoofs behind, and then a yell. I looked around and saw one of them dashing down the line. I took out my own gun, as I did not know whether there was going to be something doing or not. He galloped up alongside, and I waited for something exciting to happen. To my surprise, he pulled out a little bunch of flowers, wrapped up in a small American flag, and said: 'Here, boys, plant these here colors in Paris. Luck be with you—go ahead!'

"At Cheyenne, the Thomas car had a lead of 516 miles. I made the driver who took my place promise to hold that lead, and I assure you that nobody will try to get a car to Paris more than the Thomas people."



On the Ferry from Oakland to San Francisco.

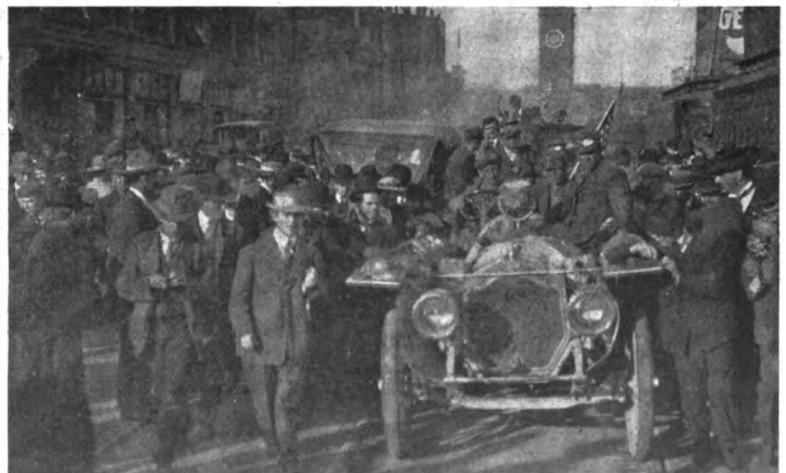

Arrival of the Thomas on Market Street, San Francisco.



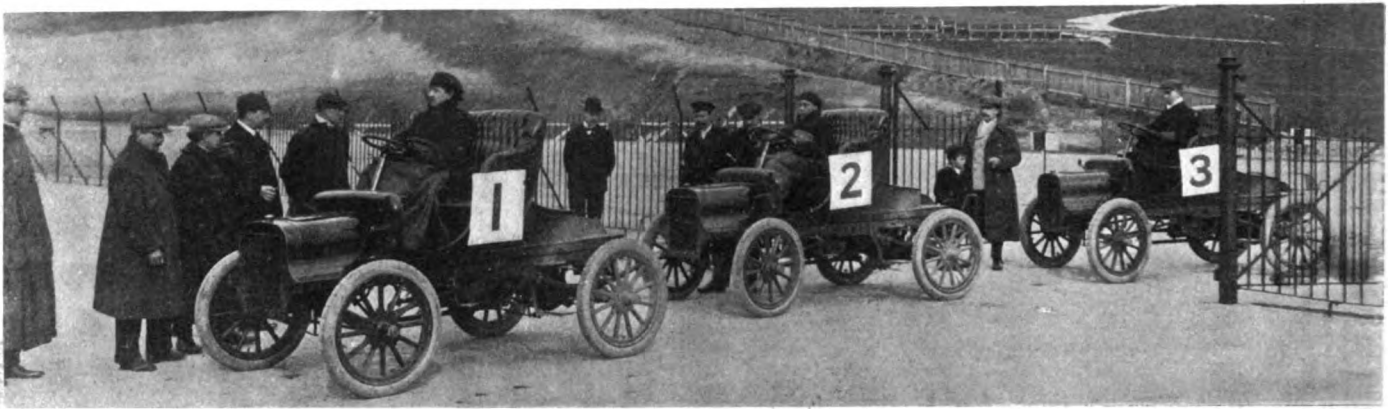

Finish of the 500-miles Trial of the Reassembled Cadillacs at Brooklands Track, England.

### BRITISH SUCCESS OF CADILLAC CARS.

LONDON, March 19.—A trio of Cadillac cars have just successfully emerged from a most severe test of standardization at the hands of the Royal Automobile Club. These popular cars are noted on this side for their reliability, and it was in order to establish an equally strong reputation for their parts standardization that F. S. Bennett, the manager of the English branch, proposed the present test.

Two members of the trials committee of the club visited the Cadillac sales depot and selected three 10-horsepower cars at random out of the stock. These were run under observation to Brooklands and straightway driven round the track for 50 miles. At the end of this preliminary jaunt the cars were taken to pieces and in three compartments of the Brooklands garage were to be seen three heaps each composed of 721 separate pieces of a 10-horsepower Cadillac. From these the judges selected at random the parts necessary for the rebuilding of the three cars, and, to show the practical utility of the standardization system, no less than 90 parts were picked out and ordered to be replaced by spare parts from the London stores. The reerection was successfully completed in quick time, the engine of the first car being started and ready to run the car round the track in 71-2 hours from the commencement.

On the two following days the three cars were run a distance of 500 miles each, the average speed for the three being 34 miles per hour and the maximum speed 39 miles per hour. The whole distance was completed without a single mechanical stop. Since this test the cars have been taken charge of by the Royal Automobile Club, and when the date of the 2,000 miles reliability trial arrives, one of the cars will be chosen by the judges to run through the trial without any preparation.

### LOCOMOBILE WINS RECORD CUP CONTEST.

MEXICO CITY, March 20.—In the race for the cup offered by the *Mexico Daily Record*, a 40-horsepower Locomobile driven by J. L. Lawrence, for the Compania Mexicana de Vehiculos Electricos made the round trip between the Country club in Chirubusco and Cuerravaca, in 3:21 flat, beating a Thomas, driven by Leandro Cuevas, by 21 minutes. Owing to the narrow roads and their crowded condition, the contestants ran over the course on different days. Considering the condition of the route, which is very hilly, and the fact that it was very crowded for a greater part of the way with peones on the way to market from Morelos, the speed made was remarkable, quite a few stretches being done at 60 miles an hour and better. No tire trouble was encountered, and but five minutes were lost in replenishing the radiator, this being the only stop on the trip aside from those necessary to avoid pedestrians and burros.

### HOTCHKISS TALKS TO THE CANADIANS.

TORONTO, ONT., March 28.—The annual dinner of the Ontario Motor League, held last night, was a notable affair. One of the principal speakers was President William H. Hotchkiss, of the American Automobile Association, whose remarks found much favor with those present, for the reason that just now the Canadians are experiencing some very annoying forms of drastic legislation which they hope to have modified.

Duncan McDonald, president of the Automobile Club of Canada; U. H. Dandurand, vice-president of the Ontario Motor League; Mayor Oliver, E. B. Ryckman, K.C.; Dr. Godfrey, M.P.P.; Lloyd Harris, and William Stone were among the other speakers who addressed the gathering.



Committee of the Royal Automobile Club Mixing the Parts of the Three Cadillacs, and Handing Out Set for No. 1 Car.

# GRAND PRIX PLANS ARE NOW WELL UNDER WAY

PARIS, March 28.—After considering several schemes the Automobile Club of France has decided on a form of grandstand for the Grand Prix differing from any adopted heretofore. The main stand and everything connected with it is on the outside of the course about half a mile from the Dieppe hairpin turn. On the inside of the course is nothing but the starter's box and the scoreboard, this latter being a long, low placard, its highest point less than three yards from the ground. Opposite the grandstands the road has been made double width, the inner half being reserved for cars running in for tires, gasoline, or other provisions. A long, shallow pit has been built the full length of the inner road, and it is in here that the gasoline and tire stations will be established. Behind this row of boxes is a passage communicating with the entrance to each stand. The grandstands proper commence some distance from the tire stations and rise up at such an angle as to allow a perfect view from every row. The general arrangement recalls forcibly that of Madison Square Garden for the six-day bicycle race; the circular passage between the spectators' seats and the track, in this case, being the tire and gasoline stations. At one end of the grandstand will be a high tower, one story of which will be reserved for notables and the other to members of the press, telegraph connection being brought into the rear of the press room. Behind the main buildings will be the garages.

Being on the outside of the course access to and from the grandstands will be possible at all hours, even the main road from Dieppe can be kept open until a quarter of an hour after the start. Should it be considered necessary the racers will be started from the inner half of the road leaving the main portion of the course free for the passage of cars finishing the first round and passing at speed. As each machine must cut in for stoppages to take on gasoline and change tires the full width of the road opposite the grandstands will never be encroached upon for this purpose.

Racing drivers are already active on the Dieppe course, and so great has been the rush of automobiles to the Dieppe triangle that the police have had to take special measures to enforce the

speed regulations in all villages. Panhard, Brasier, Bayard-Clement, and Renault have been among those putting in a large amount of time during the past week. The three Renault racers now out have a close resemblance externally to those of last year. The four cylinders, cast in pairs, are 155 millimeters bore by 160 millimeters stroke, which is rather less than the majority of French cars constructed for the Grand Prix. Valves are all on one side, operated by a single camshaft. The engine is cooled on the thermo-siphon system, with multi-tubular radiator behind the engine, according to general Renault practice. There are three speeds forward by progressive sliding gear, shaft drive, and according to the driver's declaration, no differential. It will be remembered that the Renault which captured the first Grand Prix was also without differential.

An idea of the effort that is being made by Mercedes to recapture speed laurels may be judged from the fact that ten racing cars are being built, three of which are already on the road. In general lines there is nothing which distinguishes them from last year's models. The engine is declared to have the maximum bore and a stroke of 170 millimeters. Low tension magneto is employed with Bosch magneto.

Great Britain has selected an excellent team of racing drivers for the three Austin cars entered in the Grand Prix. Lee Guinness, the rich amateur driver, known to the world by reason of his connection with a certain brand of stout, stands forth in the automobile world as the owner of the 200-horsepower eight-cylinder Darracq, recognized as the fastest car in the world. Resta, who will handle the second car, has an excellent reputation as a driver of fast cars on Brooklands track, and Warwick Wright, the Darracq representative in England, has already won sufficient races at Brooklands and on the road for him to be considered the equal of any of the Continental drivers. Weigel, who drove his own car in the last Grand Prix, will be a spectator this year, the withdrawal of his license making it impossible for him to handle a car in his own country. The only driver who has been definitely selected is Coleman, an automobilist little known outside of home circles.

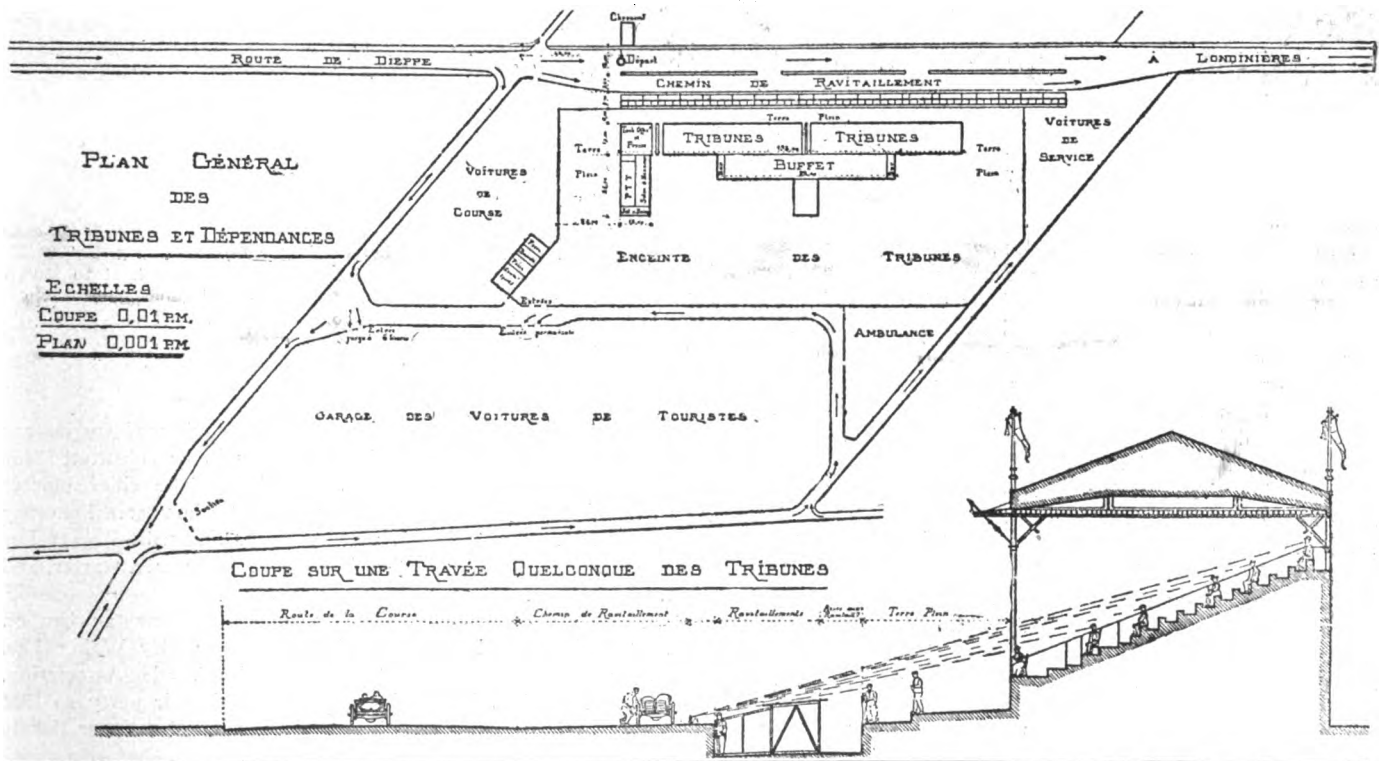

Grand Stand Arrangement for the Grand Prix—Upper Design Shows Floor Plan—Lower Design Shows Side Elevation of Stand.

## FATHER KNICKERBOCKER SEEMS KEEN FOR THE CARNIVAL

EVERYTHING is now in readiness for next week's carnival in New York City to celebrate the tenth trade birthday of the automobile in this country and to formally open the selling season of 1908. Indications point to an automobile function far greater in magnitude than the most sanguine of its promoters of the New York Automobile Trade Association ever expected. Already "Automobile Row" is beginning to take on its holiday dress of bunting and carnival flags. Letters are pouring in on the dealers telling them of the intention of the writers to make a week of it in New York. Whether the big selling counted on occurs during opening or at a later week, the New York tradesmen are well satisfied that they will have given automobiling locally a big and beneficial boom at a time when some weak-kneed ones were a bit shaky over trade prospects.

Carnival week will be marked by four specially scheduled features, three of them taking place at night so as not to interfere with the examination and purchase of cars, which will be one of the main objects of many of the visitors to town.

mally entered in competition for first and second prize trophies for artistic beauty of embellishment. A trophy will also be awarded the most grotesquely decorated car. No names, signs, or other advertising features will be permitted in this division.

A division, which promises much in the way of exploitation of the business utility of the automobile is the fourth, whose place of assemblage will be Fifty-fourth street. To it are assigned not only commercial cars of every type, but also floats for advertising purposes.

On the night of the parade Eighth and Ninth avenues will be closed between Fifty-third and Fifty-eighth streets.

Novel judges' and reviewing stands have been conceived. They will consist of sight-seeing 'buses and touring cars parked on either side of the esplanade on Broadway between Eighty-seventh and Eighty-eighth streets facing the curbs on either side.

The hill-climb will take place at half past one o'clock on Thursday afternoon on Fort George hill, starting at Dyckman street, which has a station on the Broadway division of the



A Practice Trial by a Rambler on Fort George Hill, where Carnival Event Will Take Place.

On Tuesday night there will be a monster parade of illuminated and decorated cars. Thursday will be given over to a series of hill climbing contests at Fort George. A joy ride is scheduled for Friday night with Gramatan Inn, at Bronxville, as the place of rendezvous, and a banquet there as the attraction. Carnival week will wind up with a trade smoker at the A. C. A.

The trade will have for its grand marshal R. G. Howell and will move in four divisions. The route to be followed will be down Broadway to Twenty-fifth street, east to Fifth avenue, north to Fifty-ninth street, west to Broadway, and north to One Hundred and Tenth street, where it will countermarch down Broadway and disband at Columbus Circle. The first division will form in Fifty-seventh street. The place of honor in it will be given to the pioneer models of 1903 and earlier vintages. Following the old 'uns as an escort will be the racing cars, veterans of famous contests of the past, and candidates for coming struggles on road and track. The second division will line up in Fifty-sixth street. This will be the dealers' section and be a moving exhibition of all the models of 1908. No decorations or advertising will be allowed on the cars beyond the name of the dealer.

Great interest from a spectacular and competitive standpoint will attach to the third division, which will form in Fifty-fifth street. It will be made up exclusively of decorated cars for-

subway. The program as arranged by the committee follows:

1. Gasoline cars selling for \$850 or less.
2. Gasoline cars selling from \$851 to, and including, \$1,250.
3. Gasoline cars selling from \$1,251 to, and including, \$2,000.
4. Gasoline cars selling from \$2,001 to, and including, \$3,000.
5. Steam, gasoline or electric cars, selling from \$2,001 to \$3,000.
6. Gasoline cars selling from \$3,000 to, and including, \$4,000.
7. Four-cylinder cars selling for more than \$4,000.
8. Six-cylinder cars selling for more than \$4,000.
9. Free-for-all, open to cars of all motive powers.
10. Open to steam cars only.
11. Open to electrics of all types.

It has been decided that if a sufficient number of entries are received for the climb, suitable trophies will be substituted for the ribbons originally intended as prizes. The chief officers chosen for the climb are Jefferson deMont Thompson, honorary referee; A. R. Pardington, referee; C. J. Edwards, Robert Lee Morrell and A. G. Batchelder, judges; F. J. Wagner, starter, and the Timers' Club of New York, timers.

Those desiring to join the banqueters at Gramatan Inn on Friday night should not later than Monday notify Walter Lee, secretary of the New York Automobile Trade Association, Bryant Park building, giving the names of their party so that seats may be reserved together. The price of the dinner tickets have been set at \$1.25. It is not a stag affair, ladies being also expected.

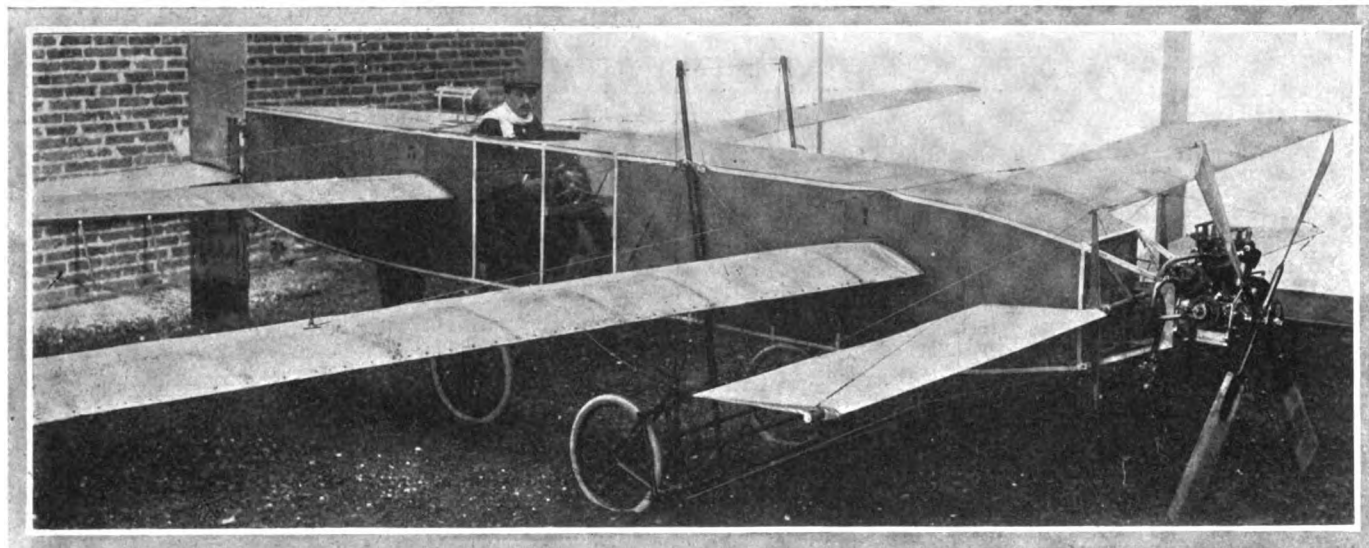

The New Paulham-Kaepferrer Aeroplane with Its 35-horsepower, Six-cylinder Motor and Four-bladed Propeller.

**FARMAN IS STILL THE AIR CHAMPION.**

PARIS, March 28.—Henry Farman is still the world's champion flyer. Since winning the Deutsch-Archdeacon prize, the Anglo-French aeronaut has been occupied almost exclusively with the rebuilding of his machine. Yesterday evening, at the Issy-les-Moulineaux ground, he made two flights of the most successful nature, the first one being over a distance of one and a half miles in 2 minutes 50 seconds, and the second over a circle estimated at 1.8 miles in 2 minutes 55 seconds. Unfortunately, the officials of the Aero Club were not present to control the flight, and, in order that all may be regular, Farman has given official notice of his intention to fly in the presence of an Aero Club delegation against his own record.

In the course of the trials, while Farman was practising circling, he gave the machine too much inclination, and, as the machine was close to the ground, one of the wings struck the ground while going at a good rate of speed and threw the inventor out. He left some of the skin of his nose and forehead on the ground, but was otherwise unhurt.

**An Appeal for Prizes.**

PARIS, March 28.—Ernest Archdeacon, who, with M. Deutsch, gave the \$10,000 prize recently won by Henry Farman, has made an appeal, through the Paris *Herald*, to wealthy Americans to subscribe the sum of one million francs (\$200,000) for prizes to encourage the science of aviation. By offering prizes instead of spending money on personal experiments, M. Archdeacon says that fully \$100,000 was expended in attempting to win the prize, and unthought-of progress was the result. He is of the opinion that there are plenty of men in America who can afford to give largely, and he may even undertake an expedition to America for that purpose. How much success he will have should he cross the ocean is considered rather problematical.

**GERMAN AERONAUTIC INTEREST KEEN.**

BERLIN, March 27.—German patriotism has been aroused to the extent of offering a prize of \$10,000, which has been handed over to the German Aeroplane Club by Karl Lanz, a Mannheim merchant, to be contested for by machines of the heavier-than-air type. They must be constructed entirely in Germany, and of German materials. The competition will be held on the Tempelhof parade ground. Herr Lanz has also donated \$2,500 to aid poor German aeroplane inventors.

Progress has been so rapid that the Aero Club has now established itself in a splendid new home at Wollendorf Platz, No. 3, the quarters comprising meeting, dining, smoking and tea rooms, beside an assembly hall, and are elaborately fitted throughout. The club has also taken a country house, and its members are looking forward to a most prosperous future. It is understood that the emperor is taking increased interest in aeronautical matters, and greater recognition is expected from him in future.

**AERONAUT BISHOP TALKS**

NEW YORK, April 1.—At the fortnightly entertainment of the Automobile Club of America, held at the clubhouse Tuesday evening, Cortland Field Bishop, president of the Aero Club of America, delivered a lecture, entitled, "Some European Highways as Seen by an Automobilst." His lecture dwelt particularly upon the value of the strategic mountain roads of the French side of the Franco-Italian frontier, and was profusely illustrated with lantern slides made from negatives taken by Mr. Bishop himself while touring the Continent. The talk was one of the most interesting that the club members have been treated to in a long while, and was enthusiastically received, as it showed in a most striking manner the tremendous amount of work that must be done in this country before America can claim to have a highway system that can be dignified by this title.

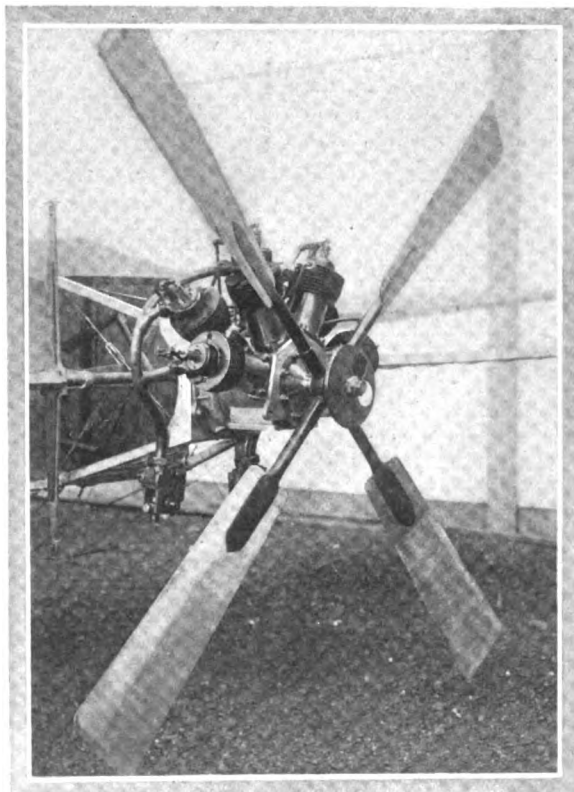

Propeller and Housing of the Paulham-Kaepferrer.



# WHAT IS BEING DONE IN CLUBDOM

## FIGURES FROM CLUB DYNAMOMETER TESTS.

NEW YORK CITY, April 1.—A report has just been issued by the Automobile Club of America showing the results that have been obtained in the dynamometer tests of 17 different machines, most of them being owned by members. As will be recalled the dynamometer is designed to show not only the working horsepower of a car, but also the speed in miles per hour and feet per second, according to the gear used; the hill-climbing ability, and the holding-power of the brakes. The power reading is taken at the rear wheels in contrast with the usual motor rating, which does not take account of transmission losses, usually averaging about 25 per cent.

Although the cars are tested on all speeds and on each gear, in the following tabulated results of the tests, only one speed is given. In this table, it will be noticed that some of the cars give an output at the rear wheels in excess of their rating, though the latter is, in many cases, only nominal. One of the Packard "30" 1907 models, belonging to J. M. Fiske, showed 33 horsepower, on the first speed, while G. E. Schanch's "30" Peerless also showed the same rating on this speed. The smallest car tested was a Delahaye taxicab, which is in daily service about the city. On third speed it showed an output of 5.25 horsepower. The table is as follows:

Car, H.P., and Type	Maximum H.P. at Wheels	Miles Per Hour	Gear
Mercedes, 40, runabout.....	29	42	4th
Pope-Hartford, 30, touring.....	25½	36	3d
Westinghouse, 35-40, touring.....	30	25½	2d
Stoddard-Dayton, 40, runabout.....	30	43	3d
Packard, 30, runabout.....	33	12	1st
Pierce Arrow, 40 (6 cyl.), touring.....	30	43	3d
Pierce Arrow, 28-32, touring.....	21½	11	1st
Simplex, 50, touring.....	44	46	3d
Packard, 24, limousine.....	20%	13	1st
Stoddard-Dayton, 40, runabout.....	24	44½	3d
Oldsmobile, 35, runabout.....	15	34½	3d
Stevens-Duryea, 30 (6-cyl.), touring.....	26	40	3d
Delahaye, 8-9, landaulet.....	5½	25	3d
Locomobile, 15-20, limousine.....	13½	7	1st
Thomas, 40, runabout.....	23	40	3d
Peerless, 30, touring.....	33	14	1st
Packard, 30, touring.....	35	28	2d

## NOTED NAMES AMONG A. C. A. NOMINEES.

NEW YORK, March 30.—The regular ticket put forth by the nominating committee of the Automobile Club of America will give the club several new officers not hitherto connected with the management of the club. It embraces names high up in financial business and social life, whose various connections therewith are well known. The nominees, who have been approved by the board of governors and will be voted upon at the annual meeting of the club on April 14, are: President, Judge E. H. Gary; first vice-president, Henry Sanderson; second vice-president, William G. McAdoe; third vice-president, Robert Lee Morrell; treasurer, Edgar L. Marston; governors, Cornelius Vanderbilt, General Horace Porter, F. D. Underwood, W. Pierson Hamilton, Colgate Hoyt, Waldron Williams, and Dr. Schuyler S. Wheeler. The governors who will remain in office are: Winthrop E. Scarritt, Dave Hennen Morris, Col. John Jacob Astor, George F. Chamberlin, and Albert R. Shattuck.

## CINCINNATIANS SECURE HOTEL CLUBROOMS.

CINCINNATI, March 30.—Permanent clubrooms have been secured on the second floor of the Gibson House for the use of the Automobile Club of Cincinnati. The recent annual election of the club resulted in the choice of the following: President, Dr. Charles L. Bonifield; first vice-president, C. Gordon Neff; second vice-president, D. McKim Cooke; secretary, Dr. L. S. Colter; treasurer, Harry L. Manss; consulting engineer, E. J. Carpenter; board of governors, G. W. Drach, Val Duttonhofer, Jr., Dr. A. B. Heyl, C. E. Bultman, Paul H. Verkamp, and Louis Merkel. The three last named are recent recruits.

## \$10,000 IN GUIDEPOSTS FOR CHICAGO.

CHICAGO, March 30.—Thanks to the signboard committee of the Chicago Motor Club, 1,000 miles of roads embracing eleven different routes leading from the city, are to be marked by guideposts. The cost of this great plant is estimated at from \$7,000 to \$10,000. Already the order for the first 1,000 signs has been placed. Most of the work will be done this summer, and when completed Chicago will have set a shining example to motordom of what can and ought to be done by the clubs, dealers, and automobilists at large of every city. The setting out of the posts and the erection of the signs will be begun by May 15. The committee counts on having at least four of the routes covered by June 1. A donation of \$1,000 by the Chicago Motor Club, and of \$350 by the Chicago Automobile Trade Association, added to \$539 from the old signboard commission, formed the nucleus of the fund. The signs will be of cast iron and the posts of cedar, 10 feet high. The posts and the background of the signs will be painted white to contrast at night with the black letters. The metallic paint will be renewed annually.

The routes to be marked are those to South Bend, Ottawa, Rockford, Cedar Lake, Ind., Kankakee, Lake Geneva, Milwaukee, Fox Lake, and Aurora and Elgin. Members of the signboard committee, which consists of J. V. Lawrence, Harry Branstetter, E. Q. Cordner, Paul Picard, Berne Nadall, W. H. Mason, O. G. Temme, N. H. Van Sicklen, Jr., and William R. Johnson, have already marked out the location of the posts. The signs will also give warning of hills, deep cuts, turns, railroad crossings, and other danger places ahead.

## FIRST RUN OF NEW PENNSYLVANIA CLUB.

PHILADELPHIA, March 30.—Many local automobilists are preparing to take part in the first annual endurance run of the Norristown Automobile Club, which is scheduled for Tuesday, April 28. The route selected, which is about 123 miles in length, will be triangular in shape, with Norristown, Lancaster, and Reading at the three corners. A total of 7 hours 15 minutes will be allowed to cover the course. There will be checking stations at Coatesville, Lancaster, Reading, Pottstown, and Norristown. The going is sufficiently varied to make the run a hard test. The Lancaster-Reading leg, 31.7 miles, for which 1 hour 55 minutes will be allowed, will furnish the hardest going, and, if the weather be wet, clean scores will be a *rara avis*.

## MILL CITY AUTOMOBILISTS ORGANIZE.

FALL RIVER, Mass., March 30.—Autoists of this city and vicinity have formed the Fall River Automobile Club. The new club has secured a charter from the Secretary of State and elected its first board of officers as follows: President, Dr. George L. Richards; vice-president, Earle P. Charlton; secretary, Arthur S. Phillips; treasurer, Albert A. Harrison; directors for three years, Earle P. Charlton, Robert Marshall, John P. Hilton; directors for two years, George L. Richards, Edward B. Jennings, Edmund Cote; directors for one year, Herbert C. Talbot, George D. Flynn, and Edward B. Remington.

## DEAD HORSE HILL CLIMB MAY BE REVIVED.

WORCESTER, Mass., March 30.—The governors of the Worcester Automobile Club have called a meeting to decide on a date in May, at which time the annual meeting of the club and the elections of officers for the ensuing year will be held.

It is expected that the Dead Horse Hill climb will come up for consideration and discussion at this meeting.

At this meeting will be chosen the successor of the late secretary of the club, Robert M. Pratt. I. C. Caton has been acting as secretary since Mr. Pratt's death.

## GOVERNMENT TESTS ALCOHOL AND GASOLINE

THE Technologic Branch of the United States Geological Survey, under the direction of J. A. Holmes, has recently completed an elaborate series of tests on the relative value of gasoline and alcohol as producers of power. The tests, over two thousand in number, probably represent the most complete and exact investigation of the kind that has been made either in this country or abroad, and include much original research.

Professor R. H. Fernald, Engineer in Charge of the Gas Producer Section and professor of mechanical engineering in the Case School of Applied Science, Cleveland, O., was in general charge of the tests. R. M. Strong, formerly connected with the engineering department of Columbia University, had personal supervision of the work. He was assisted by a corps of specially trained men. These tests were conducted at the Fuel Testing Plant of the Geological Survey at Norfolk, Va., and show the following results in regard to the comparative fuel

revolutions per minute, while the alcohol engines were of similar construction and identical in size with the gasoline engines. The air was not preheated for the tests, and the engines were equipped with the ordinary types of constant level suction lift, and constant level pressure spray carbureters. Many special tests with air preheated to various temperatures up to 250 degrees Fahrenheit, and tests with special carbureters were made, but no beneficial effects traceable to better carburetion were found when the engines were handled under the special test conditions, including constant speed and best load.

The commercial completely denatured alcohol referred to is 100 parts ethyl alcohol, plus 10 parts methyl alcohol, plus .5 part benzol, and corresponds very closely to 94 per cent. by volume, or 91 per cent. by weight, grain alcohol. No detrimental effects on the cylinder walls and valves of the engines were found from the use of the denatured alcohol. The lowest consumption

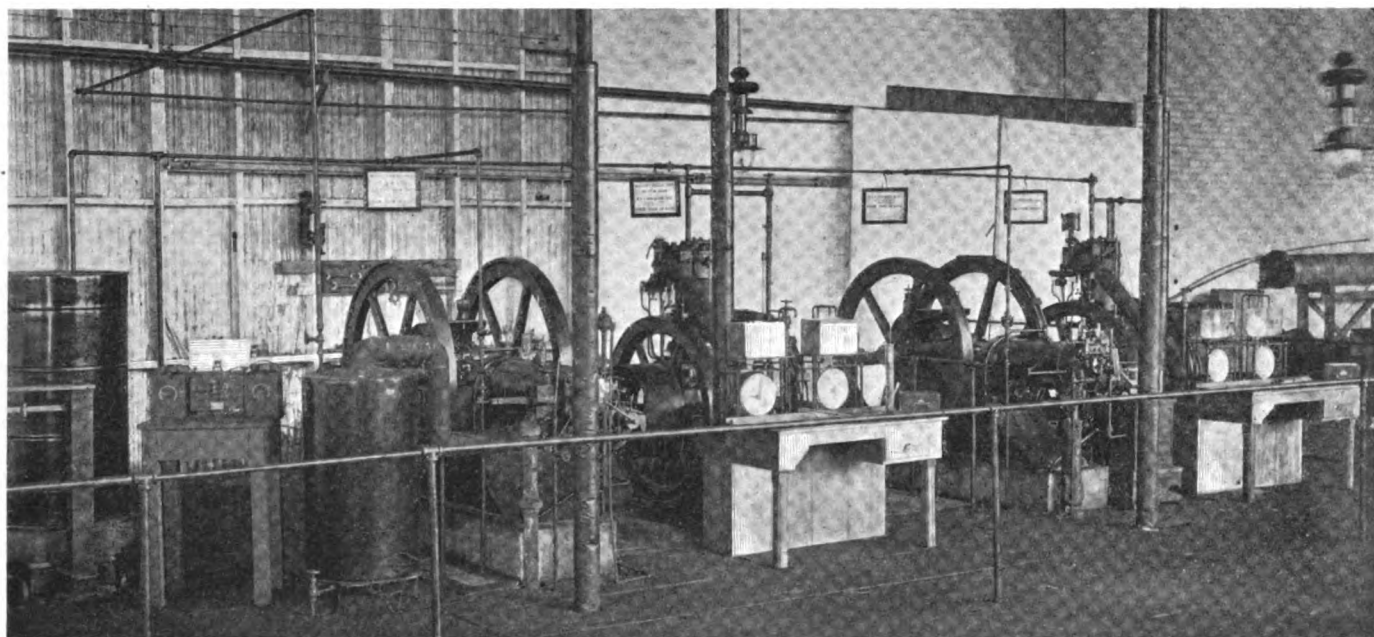

Interior View of the Government's Specially Equipped Fuel-testing Plant at Norfolk, Va.

consumption of 73 degree specific gravity gasoline and commercial completely denatured alcohol, per unit of power.

Correspondingly well-designed alcohol and gasoline engines, when running under the most advantageous conditions for each, will consume equal volumes of the fuel for which they are designed. This statement is based on the results of many tests made under the most favorable practical conditions that could be obtained for the size and type of engines and fuel used. An average of the minimum fuel consumption values thus obtained gives a like figure of .8 pint per brake horsepower hour for gasoline and alcohol.

Considering that the heat value of a gallon of the denatured alcohol is only a little over .6 that of a gallon of gasoline this result of equal fuel consumption by volume for gasoline and alcohol engines probably represents the best comparative value that can be obtained for alcohol at the present time, as is also indicated by Continental practice. Though the possibility of obtaining this condition in practice here has been thoroughly demonstrated at the government Fuel-Testing plant, it yet remains for the engine manufacturers to make the "equal fuel consumption by volume" a commercial basis of comparison.

The gasoline engines that were used in these tests are representative of the standard American stationary engine types, rating at 10 to 15 horsepower, at speeds of from 250 to 300

values were obtained with the highest compression that it was found practical to use; for the denatured alcohol, this ranged from 150 to 180 pounds per square inch above atmospheric.

Eighty per cent. alcohol (alcohol and water), for use in engines of the present types, would have to sell for at least 15 per cent. less per gallon than the denatured alcohol, in order to compete with it. The minimum consumption values in gallons per brake horsepower hour, for 80 per cent. alcohol, is approximately 17.5 per cent. greater than for the denatured alcohol used, or for gasoline. A series of tests made with alcohol of various percentages by volume, ranging from 94 per cent. to 50 per cent., showed that the minimum consumption values, in gallons per brake horsepower hour, increased a little more rapidly than the alcohol decreased in percentage of pure alcohol. That is, the thermal efficiency decreased with the decrease in percentage of pure alcohol. This decrease in thermal efficiency, or increase in consumption referred to for pure alcohol, is, however, comparatively slight from 100 per cent. alcohol down to about 80 per cent. alcohol. Within these limits, it may be neglected in making the calculations necessary to compare the minimum consumption values for tests with different alcohol percentages.

The purer the alcohol is, the greater the maximum horsepower of the engine. The reduction in maximum horsepower for 80 per cent. alcohol, as compared with that for denatured alcohol

used, was less than 1 per cent., but the starting and regulating difficulties are appreciably increased.

With suitable compression, mixtures of gasoline and alcohol vapors (double carbureters) gave thermal efficiencies ranging between that for gasoline (maximum 22.2 per cent.) and that for alcohol (maximum 34.6 per cent.), but in no case were they

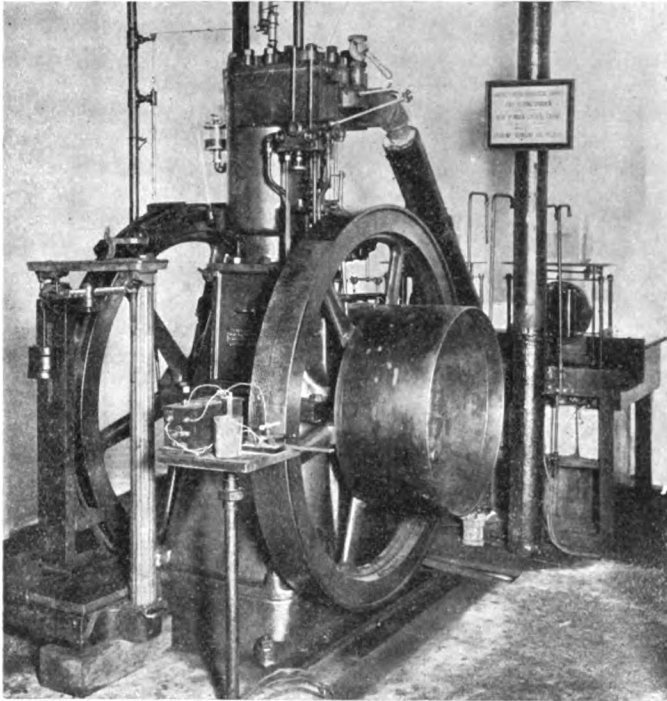

One of the 10-Horsepower Nash Engines Used.

higher than that for alcohol. The above thermal efficiencies are calculated from the brake horsepower and the low calorific value of the fuel, which, for the gasoline, was 19,100 B. t. u. per pound, and for the denatured alcohol, 10,500 B. t. u. per pound.

As has been previously published, alcohol can be used with more or less satisfaction in stationary and marine gasoline engines, and these gasoline engines will use from one and one-half to twice as much alcohol as gasoline, when operating under the same conditions. The possibilities, however, of altering the ordinary gasoline engine as required to obtain the best economies with alcohol are very limited. The amount that the compression can be raised without entirely redesigning the cylinder and valve arrangement, is ordinarily not sufficient, nor are the gasoline engines usually built heavy enough to stand the maximum explosive pressures, which often reach six and seven hundred pounds per square inch. With the increase in weight for the same size engine designed to use alcohol instead of gasoline, comes an increase in maximum horsepower of a little over 35 per cent., so that its weight per horsepower need not be greater than that of the gasoline engine, and probably will be less.

The work was taken up to investigate the characteristic action of fuels used in internal combustion engines with a detailed study of the action of each fuel as governed by the many variable conditions of engine manipulation, design and equipment. These variables were isolated, as far as possible; their separate and combined effects were determined, worked out under practical operating conditions, and led up to the conditions required for minimum fuel consumption. The results show the saving that can be obtained over conditions for maximum consumption, and also establish a definite basis of comparison under conditions most favorable to each fuel. This latter is a point of much commercial interest, and a study of the comparative action of gasoline and alcohol may be of great service in solving some of the general internal combustion engine problems where other than liquid fuels are used.

A large number of fundamental tests were necessary in order

to clearly define conditions and interpret results. In a way, they follow the work conducted by the Department of Agriculture, supplementing to a certain extent, but not duplicating, Bulletin 191, which gives much data of general value. Many of the tests of internal combustion engines have been made, but most of them, especially in this country, were by private concerns, for a specified purpose, and the results are not generally available. Furthermore, as is generally recognized by those familiar with gas, and especially gasoline engine operation, the conditions influencing engine performance are so numerous and various as to make the value of off-hand comparison very limited and often misleading, exact comparisons only being possible under identical conditions, or with reference to the actual known differences in all conditions that influence the results.

### FASTENING FLANGES TO TUBES.

By E. T. BIRDSALL, M.E.

In the design of most automobiles and motor boat engines, steel and copper tubing having comparatively thin walls is used for inlet, exhaust and water conduits. This tubing is connected to the engine and its accessories by means of flanges, usually by soldering or brazing. The brazing of the flanges to the tubes is an expensive operation calling for a brazing plant, and the soldering always gives more or less trouble. In addition, there is the labor of cleaning off the scale and surplus brazing or soldering material from the parts, which are often seriously damaged by the heat required in the operation.

The process of rolling or expanding the tubes into the flanges, or other parts, in exactly the same manner as boiler tubes are secured into a boiler shell, has been used by the writer for some time with perfect success. The only tool necessary is a roller-expander having the rolls specially shaped for the work. In the illustration, the flange is shown with a recess turned in its interior and the roller is so shaped and adjusted that when the stop on the expander is against the end of the tube, the greatest diameter of the rolls will be opposite the recess of the flange.

The job shown is a 1 3/4-inch O. D. seamless steel exhaust pipe of No. 16 gauge, expanded into a steel casting flange. The pipe projects 1-8 inch beyond the face of the flange and into the exhaust manifold in order to prevent the gasket from blowing out.

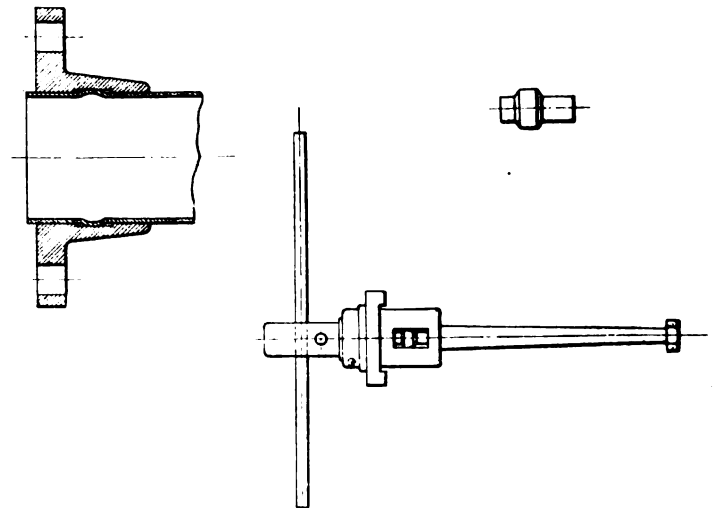

Simple Method of Fastening Flanges to Tubes.

These joints can be made by one man and require about five minutes each. They are absolutely gas-tight and present a very neat and workmanlike appearance. A tube can be securely fastened in this manner to a part, that, owing to its low melting point, shape, location, or other cause, would not admit of the brazing process, and the job when made in this fashion is not only far neater in appearance, but is likewise much more durable and is not apt to give trouble at an unexpected time.

# COMPARISON OF FOUR AND SIX-CYLINDER MOTORS

By ARTHUR H. DENISON.

NOW that the amusing comparisons by enthusiastic manufacturers of four and six-cylinder engines of the centipede, spider, horse, ostrich, and "even peaches growing on cedar trees" types is at an end, the purchasing public is interested mostly in the dollars question; also what actually takes place in the four-cylinder and the six-cylinder motors, that one is claimed to be so much superior to the other. Judging from questions asked on the subject, there may be a widespread impression that the addition of two cylinders is merely an excuse to hide defects in the design and construction of the four-cylinder motors. Here

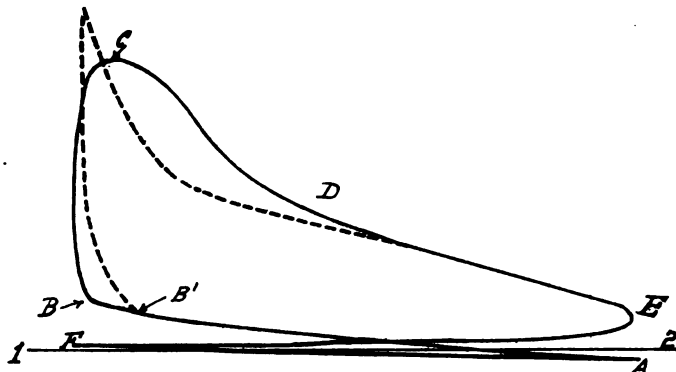

Fig. 1.—Typical indicator diagram showing average efficiency.

it may be said that a theoretically perfect motor, if such could be built, will give most unsatisfactory results, if subjected to inexperienced handling.

Consider first the four-cylinder, four-cycle motor. This represents the highest efficiency possible to obtain for general touring purposes, from the least number of cylinders and the minimum weight. Giving one power impulse for every half revolution of the flywheel the four-cylinder motor when turning at a speed of 300 revolutions per minute or more and propelling the car, causes so little vibration that one is conscious only of the smoothness and quietness of the machinery—assuming a well-built car, of course. If the car is standing and the motor running slowly, vibration cannot be escaped under any conditions or with any motor, and usually it is disagreeable to the occupants of the tonneau. In order to effectually compare the four and six-cylinder motors, we must thoroughly understand the relations of the essential parts of each motor, the flywheel, pistons, carbureter, etc., and their influence on the action of the motor.

Fig. 1 is taken from a photographed diagram of a four-cylinder motor, but the diagram, showing what took place in an individual cylinder, may be considered as a typical diagram of one-cylinder, irrespective of whether a one, two, four, six, or eight-cylinder motor is under discussion. *F* indicates the beginning of the suction stroke; *A* the lower dead center and commencement of the compression stroke, ignition taking place at *B*, the pressure rising to about 15 atmospheres at *C*, and the curve *D*, the drop in pressure to the exhaust valve opening at *E*. Therefore, the distance from *F* to *A* represents one-half revolution of the flywheel on the length of the motor's stroke. The line 1-2 indicates the line of atmospheric pressure. This diagram represents a fairly high standard of efficiency. Its faults are: Ignition was a little retarded, taking place almost on dead center. The exhaust stroke finishing slightly above the line of atmospheric pressure indicates trouble in getting rid of the exhaust, possibly in valve-timing or in the muffler, and this will materially affect the action of the carbureter and quality of the mixture in the following suction stroke. This is indicated by the end of the suction stroke lying below the line of atmospheric pressure; therefore, what we really have during the compression stroke

is a mixture of burnt and new, or fresh, gas that will cause a fairly high compression, yet poor explosion, because we cannot burn gas twice, and a portion of the charge is burnt gas. This diagram, considered as taken from cylinders No. 2 or 3, may show a slightly higher efficiency than from cylinders No. 1 and 4, due to inlet and exhaust manifolds and water connections. If ignition had taken place nearer the theoretical point *B I*, the dotted line would represent the curve, showing slightly more power developed.

In a four-cylinder motor, while one piston is descending on its power stroke, another one is ascending on its compression stroke. Considering the diagram, the piston on power stroke is subject to effective pressure for about 1-4 to 1-3 of its stroke, the pressure gradually becoming weaker until, when the exhaust valve opens, it has fallen to about 1-4 of its initial pressure.

With the valve opening 30 degrees ahead on a motor with a 5-inch stroke, this represents 1-6 of the stroke or 5-6-inch. This amount of lead is absolutely necessary to allow the expanding efforts of the gas to be directed through the open valve, thus relieving the motor of much work in clearing them out, and also to reduce back pressure. There is, therefore, during each one-half revolution power being developed in one cylinder and three other pistons working yet using power. There is also a period of constant pressure against the piston lasting only a fraction of the stroke, and this energy must be stored in such a manner that the rest of the motor may draw on it without materially affecting the speed of the engine. Consequently, we have flywheels weighing up to 150 pounds and up to 28 or 30 inches in diameter. This flywheel may seem to keep the engine running smoothly, yet actually it is far from doing so.

The cylinder, whose piston is on its compression stroke, is constantly demanding more power to overcome the resistance of the gas at a time when the power stroke has practically ended and ignition taken place before dead center puts a heavy load on the flywheel to carry the piston over dead center against the pressure of the expanding gas, as the diagram, Fig. 1, shows, running as high as 15 atmospheres. Those who have felt a back-kick when cranking will realize the amount of power needed. The two other cylinders, one on the exhaust stroke and the other on the suction stroke, are also using power to overcome the resistance of valve springs as well as friction at every contact

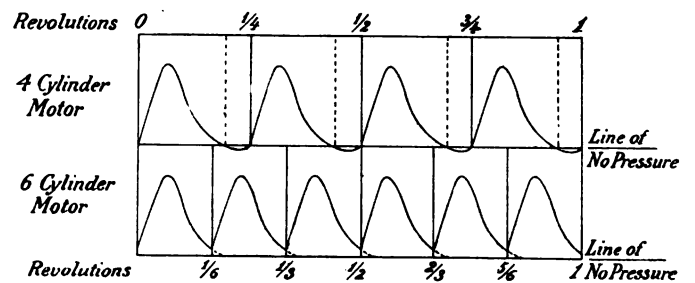

Fig. 2.—Diagram showing how in four-cylinder motor a large portion of each stroke is not developing power, the curve passing below the line of no pressure. In the six-cylinder motor the curve never reaches the line of no pressure.

point, and the flywheel must supply all of this. Thus, in one complete revolution, the flywheel must alternately receive and give energy. During this revolution, the flywheel receives energy through about 1-3 of the stroke; therefore, 2-3 of the stroke, or 2-3 of the revolution, the motor is dependent upon it, the proportions being the same.

Considering the six-cylinder motor from the same standpoint, Fig. 1 may be taken as a diagram from one of its cylinders, the dimensions being the same in both motors. The individual



operation is similar to that in the four-cylinder motor. There are also two more cylinders working; consequently, that much more power to be utilized. This is done by constructing the crankshaft in three series of two rows—see Fig. 3 and pistons Nos. 1 and 6, 2 and 5, and 3 and 4 on the same horizontal plane. Each cylinder fires separately, and,

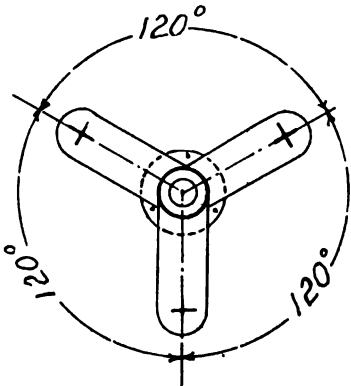

Fig. 3.—Diagram showing relative positions of the crank pins of a six-cylinder motor flywheel flange in rear. Shaft viewed from the front end.

Summing up theoretically, there is a decided advantage in favor of the six-cylinder motor, but there are many other things worthy of being taken into consideration. In the four, the flywheel, receiving and then giving energy, is subject to a certain amount of fluctuation in its speed. The impulses delivered by the motor may be likened to an alternating current wave, rising to maximum pressure, then dying away. This produces considerable vibration, which will be apparent by watching mudguards, searchlights, dash-lamps, and, in large motors, a very pronounced quivering of the whole car is seen. It also has a bad effect on the machinery, locking of nuts and bolts, and hastens fatigue. The six, on the other hand, with the steadier flow of power and the energy developed by each impulse being used directly, does not require as large a flywheel or shake things up nearly as much. The sound resembles a contented purr, the note from one exhaust blending into the next, instead of the sharp beat noticeable in the four.

The six-cylinder car cannot be called a fad. Many manufacturers are building both four and six-cylinder cars, and some exclusively sixes. One successful six-cylinder car, the Stevens-Duryea Big Six, with cylinders 4 3-4 by 5 1-4 inches, uses a flywheel catalogued at 90 pounds. On the 1906 Thomas four-cylinder 5 1-2 by 5 1-2-inch motor the flywheel weighed 105 pounds, and on the 1906 Peerless four-cylinder, 4 1-2 by 5-inch motor the flywheel weighed 96 pounds. Weight of flywheel has been a strong six-cylinder talking point, yet these figures denote much weight saved. Possibly the reason for using so large a flywheel is to take care of the motor in case of trouble: two cylinders giving trouble would have a more marked effect on the performance of the motor than one cylinder in the four, considering crankshaft in arrangement and resistance of dead cylinders. Another point is the extra weight of the engine. This is important, as a car able to stand pounding over indifferent roads must, even with fine materials, go over 3,500 pounds fully loaded and with passengers. This, with added weight of accessories, water, extra length in crankshaft,

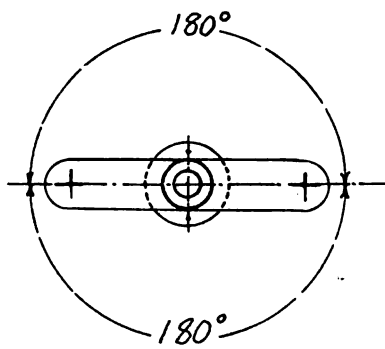

Fig. 4.—Diagram showing relative positions of the crank pins on a four-cylinder motor, with flywheel flange in rear. Shaft viewed from front end.

case, and manifolds, means a substantial amount. To keep the extra cylinders cool means larger water capacity and increased radiator surface. The increased length necessary in engine is obtained by sacrificing space in the body or tonneau, or a wheelbase so long as to make the car unwieldy. The extra power means a larger factor of safety generally, and with a motor bolted solidly to the frame, the twisting due to rough roads imposes a bending strain on the crankshaft, in addition to the load of the power impulses. This bending and twisting of the frame throws the bearings out of line also, and the crankshaft endeavoring to maintain its alignment increases enormously the strain on the bearings. This is sufficient to force the oil out, and then the shaft and bearing suffer.

The peculiar phenomenon presented by a child's top or toy gyroscope is also present in the automobile flywheel. On a powerful motor, running light, its action may be noticed by the slight movement of the frame in the direction opposite to that in which the motor is turning. The force of gyroscopic action is said to increase with the weight of the spinning disc and its speed, but this force is not very well known, and it presents many peculiar and unexplainable properties. It is seriously considered as responsible for different troubles, such as broken steering gears, tire troubles, etc., that cannot be accounted for otherwise, and its influence on the long crankshaft of the six-cylinder motor might form an interesting chapter. Recent foreign reports seem to indicate that prominent French constructors will pin their faith on four-cylinders in the coming Grand Prix race. They are also willing to build anything the public will pay for. In conclusion "price" must be put down as the deciding feature. Both types are standardized, both giving excellent service. While the six-cylinder motor overcomes the disadvantages of the four in a marked manner, the purchaser must decide for himself whether on the whole the increased weight, cost, and advantages are worth the increased price.

### GAS FLAME TO REPLACE SAW.

The employment of the oxyhydrogen blowpipe flame for industrial purposes is rapidly extending, says Robert Grimshaw in *The American Machinist*. Recently it has come into play for melting out "scaffolded" blast furnaces. It is further being used for melting off fins from castings, cutting off iron and steel, cutting out manholes—or cutting out the metal and leaving the holes, as it please you better—and naturally, for welding. This latter operation has long been done with a blast flame consisting of hydrogen and ordinary air, where of course the oxygen being less plentiful, the heating effect is not so great. Among the welding processes thus carried out is the manufacture of wrought-iron tubes from strips of wrought iron wound about a mandrel. The Ferrum Iron Works, in Upper Schlesien, has extended the oxyhydrogen welding process to the manufacture of tubes, which being intended to withstand a very severe internal air, water or steam pressure without leaking, are made of quite heavy strips of iron or steel sheet; the latter by reason of their comparatively great thickness would not lend themselves very well to the spiral rolling process, hence are made with a lengthwise weld. The principal advantage of the gas weld is, independently of the greater speed and convenience in making it, the fact that no slag is formed between the welded surfaces, hence the seam is more truly "metal to metal." The Deutsche Oxhydric Gesellschaft has for some time been making experiments as to the shape of burner, etc., best adapted to do neat and rapid work in cutting off, or in cutting out metal plates, etc. The most recent development in this line is the combination of a foreheating apparatus employing oxygen and hydrogen, with a cutting jet of pure oxygen playing on the surface previously made red hot by this oxyhydrogen jet. In the course of time, its use will doubtless be extended to a great many other processes.

# ABOUT FORGINGS FOR AUTOMOBILE WORK\*

BY RICHARD W. FUNK, MEMBER SOCIETY OF AUTOMOBILE ENGINEERS.

AS the complete subject outlined in the title may not be embraced in a short article, I will confine myself to the presentation of some few facts showing the effect of certain forging methods on nickel chrome steel as against the processes known as hydraulic and drop-forging. The information includes some results of personal experience gained in the business of making alloy steel forgings.

A certain operation known as drawing down is performed on most forgings, and it consists of hammering the piece on the square until near finish size, when the operation of rounding up begins. I have noticed that all good smiths follow this method, but have never had one in my employ who knew exactly why this was done, except that it was the quickest way to do the work. It is not uncommon to see a smith, while drawing down, allow the steam-hammer to strike with such force as to all but crush the material, often rending the structure in the case of poorer materials. Others again are timid about drawing down close to finish size before rounding up and begin the latter operation too soon, keeping the piece rolling on the anvil in the endeavor to produce a round section.

It is generally understood that hammering with care and at the proper heat improves steel, and my experience with alloy steels—that have been tested before and after being worked under the hammer—has taught me that the process of drawing down square should endure until finish size is practically reached, and that not until then should the rounding process begin; and then not by rolling around on the anvil indiscriminately, but by taking the corners with comparatively light blows. When drawing down square the blows should as nearly as possible be so gauged as to penetrate to the center and a very little beyond. The unmistakable sign will be that, in the finished piece, the core at the end will protrude a very little; not too much, as that would indicate that excessively powerful blows have been used and a crushing effect produced. As for the smith who draws square and starts to round up long before finish size has been reached, he will inevitably ruin the material.

The result of his handiwork is commonly known as piping. That is, the blows have had the effect of forming an outer shell which is drawn over the core and often separated from it in spots. This procedure leaves a hollow in the end which, in itself, should proclaim the fact that the material was not properly worked. If, on the other hand, the blows are powerful enough to penetrate to the center while working round, instead of square, there are set up continued sidewise shearing effects, shifting or sliding half of the section over the other half; in other words, the operation amounts to nothing more or less than continued violent disruptions, leaving a jagged hole extending through the length of the piece. To give some idea of the importance of the proper gauging of the hammer blows as described, in conjunction with the proper heats, I will name some actual tests in this connection that stand out in my memory.

I had occasion quite some time ago to forge a 600-pound crankshaft billet for Mr. Herreshoff, of whose endeavors you all have heard.

The normal figures of the material used were:

Tensile strength.....	125,000 lbs. per sq. in.
Elastic limit.....	118,000 lbs. per sq. in.
Elongation.....	18 per cent. in 2 inches.
Reduction of area.....	48 per cent.

The billet was hammered by myself and, after being annealed, was ready for machining, having been given no other heat-treatment of any kind.

At the works of the American and British Mfg. Co. test pieces were cut which gave the following figures:

Tensile strength.....	204,000 lbs. per sq. in.
Elastic limit.....	174,200 lbs. per sq. in.
Elongation.....	14 per cent. in 2 inches.
Reduction of area.....	45 per cent.

Against this performance I can place the figures found by Mr. Fay, our president, on testing some crankshafts of the same material, which I had the opportunity of supplying about the same time. The shafts in question were forged by the hydraulic press method—which is eminently a crushing process—then heat-treated twice most carefully, according to the best known methods at the mill where the steel was originally made, and the figures resulting were:

Tensile strength.....	154,400 lbs. per sq. in.
Elastic limit.....	133,300 lbs. per sq. in.
Elongation.....	11 per cent. in 3 inches.
Reduction of area.....	25 per cent.

The hammer method of treating shows an average improvement of 48-1-2 per cent., while the other method in combination with heat-treatment shows the slight average loss of 4 per cent.

Of course, the shafts were not made of the same piece of steel, but I have in my two years' handling of the same material found it to be what may be called uniform. Besides, as stated, the heat-treating was done at the home mill in Germany, where I know them to be very careful and painstaking, and the billet first described was forged here under very adverse and crude conditions. Again, I would not think of putting this in writing if the two years following I had not observed the same condition numberless times.

This seems to show that heat-treatment is valuable as a means of shifting the figures of physical properties to suit desired ends, but does not so much mean an all round improvement, while the material may, without a shadow of a doubt, be improved all round by observing the proper care in heating and hammering. I have further found that a shifting of physical properties may be obtained besides, as readily and nearly as accurately as by different heat-treatments. As for instance: If highest tensile strength and elastic limit with correspondingly low percentage of elongation be desired, I would work the steel at a lower heat than I would if higher figures were desired for elongation or reduction of area. In conclusion I would like to observe that I have seen figures advertised that would not uphold my conclusions, but I have in mind actual tests made by customers who wished to satisfy themselves, and not catalogue figures.

## AUTO AS AN AID TO SURGERY.

Upon being called to attend a patient far out in the rural districts, and finding him in immediate need of surgical attention with the nearest hospital 15 miles away and night falling, Dr. W. B. Reid, of Rome, N. Y., was not in a quandary but immediately set to work. The kitchen was converted into an operating room and the ironing board constituted the operating table, but the question of suitable light where nothing but unshaded kerosene lamps were to be had presented a problem until Dr. Reid thought of his auto, which was a Ford runabout. It was backed up until right under the kitchen window, one of the headlights removed and an extra length of rubber tubing attached to the tank, so that the lamp could be brought close to the improvised operating table. In the doctor's opinion, the automobile with its gas tank and lamp proved a strong factor in saving the patient's life, as he happened to have appendicitis, and the disease had already reached such an advanced stage when the doctor was called in that a delay of a few hours would certainly have proved fatal, and any attempt to move the patient, even with the aid of every facility, could only have had the same ending.

\*Paper read before the Society of Automobile Engineers at Boston, March 10-11, 1908.

## GEAR ARRANGEMENTS AND RATIOS IN AUTOMOBILES

THE fact that in the recent Scottish trials of motor cars no less than 27 per cent., or 22 out of the 81 cars which completed the trials, failed to take their load up all the hills, shows that the calculation of the gears for a car is not yet always understood, says *Engineering* (London). The fact that in the three and four-speed cars the ratio between the top and bottom speeds varied from 2 to 1 to 10 to 1 confirms this view. There were cases, no doubt, in which the failure in hill-climbing was due to defects in the engine, but in the majority of cases it was simply due to the bottom gear not being low enough, and the result could perfectly well have been foretold.

In the present state of knowledge as to motor cars there are ample data to calculate the performance of a car beforehand with as great accuracy as that of most other kinds of machinery, and, therefore, the whole subject of gears should be treated in a scientific manner. In order to calculate the performance of a car under certain specified conditions, we want to know the resistance and tractive effort. The resistance depends on—

1. That due to rolling resistance on the road.
2. That due to the gradient.
3. That due to wind.

At the speeds at which reasonable motorists go, the latter is comparatively small, and for hill-climbing purposes negligible.

The tractive effort depends on—

1. The torque the engine will give.
2. The friction of transmission.
3. The ratio of gear between the engine and back wheels.
4. The diameter of the back wheels.

Although we seldom know all these factors with absolute accuracy, we know them near enough for practical calculations.

Taking the question of the greatest resistance to be overcome first, we may take it for granted that a modern motor ought to be able to take its full load up any hill on a road habitually used for horse traffic. This means that it must take it up short stretches of 1 in 4. The resistance expressed in pounds per ton (2,240 lbs.) due to this gradient is 560 pounds. Rolling resistance will vary a good deal with the surface of the road; but as the surface on steep hills is generally bad, it may reach 100 pounds per ton, making a total tractive force required of 660 pounds per ton.

Assuming that we know the brake horsepower of the engine at the revolutions at which it gives its greatest torque, we can calculate the tractive effort as follows:

$$\text{The torque in inch pounds} = \frac{\text{Brake horsepower} \times 63,024}{\text{Revolutions per minute}}$$

$$\text{The tractive force in pounds per ton is then} = \frac{\text{Torque} \times \text{ratio of gear} \times \text{efficiency of transmission}}{\text{Weight in tons} \times \text{radius of driving wheels in inches}}$$

If there should not be an actual brake test of the engine available, as in the case of a design which has not yet been built, it is usual to estimate the power the engine will give by assuming a torque equivalent to a mean pressure in the cylinder which is estimated by experience. In this case it is simpler to use the assumed mean pressure directly to calculate the tractive force, as follows:

$$\text{Tractive force per ton} = \frac{\text{Cylinder area} \times \text{stroke} \times \text{mean pressure} \times \text{ratio of gear} \times \text{efficiency}}{\text{Circumference of driving wheel} \times 2 \times \text{weight in tons}}$$

all dimensions being in inches. If more than one cylinder, the total area to be taken.

In these formulas the only uncertain factor, if we have a brake test of the engine, is the coefficient of friction of the transmission gear. Absolutely definite experiments on hardened-steel gear wheels running under the varying conditions of motor work

are wanting; but an assumption of a loss of 8 per cent. for each pair of gear wheels through which the power passes corresponds very closely with the actual performance of cars on the road.

If we assume that there is a loss of 8 per cent. of the power transmitted for each pair of gear wheels it goes through, the following will be the efficiencies of the various arrangements. In these some small losses, such as that of the back shaft, when running idle, and that of the universal joint, are omitted. These may vary slightly in different cars, especially that of the universal joint. In a well-designed car, however, this should run practically straight, and all the small losses together should be a negligible amount. The shaft-to-shaft gear box will have an efficiency of 92 per cent on all the speeds, and as the efficiency of the bevel drive is 92 per cent., the efficiency of the whole transmission from the engine to back axle will be 92 per cent. of 92 per cent. = 85 per cent.

The direct-drive gear box, when the direct speed is in use will have an efficiency of 100 per cent., and therefore the efficiency of the whole transmission will be 92 per cent. of 100 per cent. = 92 per cent.

The direct drive-gear box, with any of the indirect speeds in use will have an efficiency of 92 per cent. of 92 per cent. = 85 per cent., and the efficiency of the whole transmission will be 92 per cent. of 85 per cent. = 78 per cent. In the case of a car with side chains there will be the friction of these in addition, which will lower the above efficiencies to about 5 per cent. all around.

In estimating the torque we are likely to get from an engine, we should assume that it is not likely to materially exceed that corresponding to 95 pounds mean pressure, even if the compression, etc., are arranged for getting the greatest possible power; though a few engines, when carefully tuned up, may reach 100 pounds. If, on the other hand, power is sacrificed to other considerations, such as extreme silence, it may be a good deal less.

It is, perhaps, easiest to show the working of a formula by taking a definite instance. Let us assume a car with four cylinders, 3 1-2 × 5 inches, weighing, with passengers, 3,360 pounds, having 32-inch driving wheels, a live axle, and a direct drive on the top speed. Assuming a torque equivalent to 95 pounds mean pressure and 78 per cent. efficiency on low speed, we get a tractive force for gear ratio 1 to 1 of

$$\frac{38.48 \times 5 \times 95 \times 0.78}{100.5 \times 2 \times 1.5} = 47.3 \text{ pounds per ton.}$$

Consequently for a tractive force of 660 pounds we must have gear ratio of

$$\frac{660}{47.3} = 14.0 \text{ to } 1,$$

equivalent to a speed of 8.2 miles an hour at 1,200 revolutions per minute of the engine.

A moderate powered car should probably be able to take its full load up about 1 in 16 on a road with a pretty good surface, which means a tractive force of about 200 pounds per ton, *i. e.*, a ratio of 3.3 between the tractive force on the top and bottom speed. The ratio of gear between the top and bottom speeds will have to be greater than this, owing to the lower efficiency of the low speeds, which is only about 85 per cent. of the top. It will therefore be about 3.9 to 1. In a low-powered car the ratio should be greater than this, as we shall not be so ambitious as to go up hills at our top speed. In a very high-powered car, however, it can be a good deal less. Probably while the low and moderate-powered car wants a ratio of about 4 to 1, the high-powered car should be about 3.5. Experience in these trials showed conclusively that it was merely a matter of either straining a point to gear a car too high for the load it was designed to carry on stiff grades, or of simply guessing at what its gear ratio should be.

## LETTERS INTERESTING AND INSTRUCTIVE

### FOUR-CYLINDER SEQUENCE OF IGNITION.

Editor THE AUTOMOBILE:

[1,278].—The writer is an owner and amateur driver who reads "The Automobile" with interest each week, and herewith takes the liberty of requesting your decision on the following point in settlement of an argument. I maintain that a four-cylinder motor, four-cycle, with piston numbers 1-4 and 2-3 parallel on a 180 degree crankshaft, must fire either 1-2-4-3 or 1-3-4-2. An automobile factory man tells me that it fires 1-4-3-2, and scolds at my assertion that this firing order is impossible.

My contention is that with piston number one at the beginning of the firing stroke, number four on the same downward stroke, and traveling parallel with number one, will be commencing its intake, and that it can fire only after another cylinder has intervened between it and number one.

My point is that, regardless of arrangement of cams for intake or exhaust, a motor cannot fire 1-4-3-2, and that with such a firing order an entire half stroke with no power application would result in number four, as the piston must, of course, be at the top of the cylinder at the time of firing. Moreover, I contend that such a sequence of firing would result in the same conditions between numbers three and two.

HARRY S. HALL.

New York City.

Your contention is quite correct. It would not be possible for the average four-cylinder automobile engine, which is constructed with the crank-throws in pairs, each pair being 180 degrees apart, to fire in the sequence 1-4-2-3, as cranks Nos. 1 and 4 and 2 and 3 are in the same plane. Counting from the forward cylinder rearward, it would ordinarily be 1-3-2-4, though this is naturally not arbitrary, as any arrangement in which a cylinder having its crank in one plane is followed by a cylinder with its crank in the opposite plane is permissible, and it will be found that many makers set their motors to fire differently in this respect. If the timer were set to spark the cylinders in the sequence 1-4-2-3, only two cylinders would be operative, the sparks for the other two occurring at a time when there was no charge under compression. A canvass of the six-cylinder motors staged at the two New York shows last Fall revealed the fact that practically every one of the permissible sequences of firing was employed on one or another.

### SELF-STARTING WITH MAKE-AND-BREAK.

Editor THE AUTOMOBILE:

[1,279].—Can you give me directions for remodeling a make-and-break ignition system so as to make a car self-starting from the seat, if this is practicable with this type of engine? The ignition system, as it is, gives excellent service, the current being supplied by a magneto, but there are times when I am almost disposed to exchange it for a high-tension system, as a means of avoiding a large part of the labor of cranking.

A. W. INGLIS.

Lafayette, Ind.

To make the change is not so simple a matter as might appear, but it can be done without resort to a high-tension system. The first essential, of course, is a battery to supply the current at starting, the magneto being capable of generating current only after the motor is under way. Then, by the provision of switches for connecting the battery and disconnecting the magneto, and some manual device for contacting and separating the make-and-break elements in all the cylinders, it becomes possible to produce the necessary spark for self-starting. As soon as the motor has taken up its cycle and is running regularly, the battery can be switched off and the magneto switched on. Naturally, with the great diversity of make-and-break systems that are in use, the application of these modifications to any given car must be worked out to suit individual conditions and requirements. With at least one system of magneto ignition now applied to a modern car, provision is made for self-starting by hand rotation of the magneto armature, which is for the moment disconnected from the regular drive.

### DIRECT-CURRENT DYNAMO FOR IGNITION.

Editor THE AUTOMOBILE:

[1,280].—I have a dynamo, manufactured by the Hillsdale Igniter Company. This dynamo has been used for current supply for a sixteen-horsepower stationary gasoline engine. Please state if the following plan will work successfully?

Place this dynamo so as to drive from the flywheel of a 22-horsepower Buick car. Run two wires to a storage battery, from storage battery to coil and commutator in the ordinary manner. Run two other wires from the dynamo to large lamps with electric globe attachment. What I want to know is, will this work satisfactorily for igniting and lighting purposes? If you think not, will you kindly suggest some plan to do away with storage battery, if possible?

Sumter, S. C.

E. W. MOISE, JR.

The dynamo may be used successfully if it is equipped with a reliable governor to prevent it attaining an excessive speed, which would cause the armature to burn out, and there is a cut-out device placed in the circuit between the generator and the storage battery to prevent the latter from overcoming the voltage of the dynamo and discharging through it when the speed drops. The lamps could not be wired directly from the generator, as the voltage fluctuates so much, due to the extremely irregular speed of an automobile motor that at one moment they would be dim and the next the filaments would burn out, due to the excessive rise, unless the governor held the dynamo speed within permissible limits. The use of a small direct-current generator is not feasible on a car without a storage battery, and there must be a reliable governor to protect the generator and a cut-out to protect the battery. There are outfits of this kind on the market that have been in successful use for a number of years. The reason why such a dynamo can be used with a stationary engine without these protective devices is because of the speed remaining constant.

### COMPUTING AN AUTO'S TRACTIVE POWER.

Editor THE AUTOMOBILE:

[1,281].—Will you please favor me with the formula for computing the tractive power of an automobile? W. W. WALLER. Washington, D. C.

The tractive force of a motor-driven vehicle may be computed with the aid of the following formula:

$$T = [a + rf + b(v-3.28)] W \div R$$

in which

$T$  = traction in pounds, this value being the sum of the two calculations for the forward and rear pair of wheels.

$W$  = gross weight in pounds upon the wheels, including the weight of the wheels themselves.

$R$  = radius of the wheels in inches.

$r_1$  = radius of sprocket, or chain-driving wheel.

$f$  = coefficient of friction for wheel bearing, which will vary according to type.

$a$  = value of rolling constant for wheels with pneumatic tires, this being 0.14 for the latter.

$b$  = value of speed constant for wheels of springed vehicles on an ordinary macadam road in fair condition, this being given as 0.25.

$v$  = velocity of vehicle in feet per second.

Of course, there are other factors to be considered, such as the resistance of the air and the extra pull required by a grade.

The gradient may be taken as 1 in a distance equal to  $N$ , and, taking  $T_1$  as the additional traction due to the incline, we have:

$$T_1 = (W + T) \div N$$

In pounds per square foot of the surface presented, the air resistance generated by the car itself alone being considered, as the wind is entirely too variable a factor, this equals the velocity of the car in (miles per hour)<sup>2</sup>, times 0.00492, or, in (feet per second)<sup>2</sup>, times 0.002288. Taking this resistance as  $P$ , and writ-



ing  $T_2$  = additional traction due to this resistance, then

$$T_2 = P(R + rf) \div R$$

But the pull of the chain in a car of that type, or the thrust of the gearing, in a shaft-driven car, produces extra pressure on the bearing, equal in a chain-driven car approximately to

$$(T + T_1 + T_2) (R - r) \div R$$

Denoting this additional traction by  $T_3$ , whence

$$T_3 = rf (T + T_1 + T_2) (R - r) \div Rr_1$$

This, then, includes all the factors of resistance to be taken into consideration, and their total may be represented by  $T_0$ , then

$$T_0 = T_1 + T_2 + T_3$$

Example: Find the tractive pull of a car of one ton gross weight, on springs, to travel at 14 miles per hour up a gradient of 1 in 30, weight assumed equally distributed on four pneumatic-tired wheels, driving wheels 36 inches, front wheels 28 inches. Driving sprocket 12 inches, axle 1 1-2 inches diameter, area of car exposed 30 square feet.

The tractive pull of the front axle will be

$$T_0 = T + T_1$$

$$= 51.6 + 39$$

While that of the driving axle will be

$$T_0 = T + T_1 + T_2 + T_3$$

$$= 40.1 + 38.6 + 29 + 1.6$$

which gives the total traction as equivalent to 200 pounds, equal to 7.4 brake horsepower. The foregoing data is from the *Practical Engineer*, London.

#### ABOUT THE RELIABILITY OF AIR-COOLING.

Editor THE AUTOMOBILE:

[1,282.]—Having read your paper for almost a year now, I am very much interested in the "Letters" on the different subjects that are brought up in each issue. I have a subject which I, with lots of other subscribers, am interested in.

Are there any air-cooled, two-cylinder, four-cycle automobile engines on the market which are as reliable and successful as the same in a water-cooled engine? In brief, is an air-cooled engine as economical or reliable and successful as a water-cooled? In your estimation would an engine air-cooled, with cylinder 5 inches in diameter by 5 1-2 inch stroke, be as efficient as one 3 1-2 inches in diameter by 4-inch stroke? Which size would be the most successful, or would there be any difference in the cooling effect?

Is friction drive on an automobile efficient and successful?

Would solid tires be successful on an automobile equipped with full elliptic springs, or would they be injurious to the car in general? Which kind would give the most and best service, a cushion or solid gum?

WM. McLOY.

Elizabeth, Pa.

There are quite a number of two-cylinder, air-cooled, four-cycle engines on the market, practically all of the horizontal opposed type. Some of them have been used on hundreds of cars that have seen service for several years, from which we should judge they were successful, otherwise they would have been abandoned long since. An air-cooled engine is more economical of fuel than a water-cooled type owing to its greater thermal efficiency, and for this reason it requires more lubricating oil, as it runs much hotter. The difference in lubricating oil consumption is nothing like sufficient to offset the economy in fuel.

If both engines were of exactly the same design and were worked under equally favorable conditions, there should be no appreciable difference in their efficiency. Judging from the fact that, except for racing purposes, air-cooled automobile motors are seldom built to exceed 4 to 4½ inches bore, probably the smaller engine might give better service in unskilled hands and under adverse conditions, but the successful performance of larger air-cooled motors would appear to indicate that there is no reason why the dimensions in question cannot be exceeded. It is more a matter of compression than of size, as the latter would only imply an increase of volume, and the former an increase in the temperature, other things remaining the same.

Judging from the number of cars equipped with a friction drive that are turned out annually, both in this country

and Europe, this type of transmission would appear to be entirely practical for every-day use.

It depends entirely upon the car and the service that is required of it. If excessive speed be not desired and the roads ordinarily traversed are fairly smooth, solid or cushion tires should give satisfaction. The solid rubber tire would probably give the better service. We do not believe there are any cushion tires for automobile use on the market to-day, though some of the solid tires made have a small hole running through the center.

#### MORE ABOUT BRAKING WITH THE HIGH.

Editor THE AUTOMOBILE:

[1,283.]—Being a constant reader of "The Automobile," I naturally take quite an interest in the "Letters Interesting and Instructive." I notice on page 358, of the March 12 issue, a letter headed the "Practical Side of the Question." In this, the man from Minnesota mentions the use of the motor as a brake, or retarder. He states that the faster the drive wheels turn the motor, the greater will be the resistance, or braking effort, which is very true. Then he says to use the high gear on a very steep grade, and the intermediate on a lesser one, which is entirely erroneous, as on the high gear the motor runs slower than on any of the others, and hence gives the least braking effort.

On the high gear, the motor turns from 2 1-2 to 4 1-2 times, according to the design of the car, while the rear wheels are turning once, while on the low gear the motor turns 9 to 11 times, and more, also varying with the design. Which will produce the greatest braking effort?

C. E. CARR.

Frederika.

Naturally, the low gear will always give the greatest amount of resistance in the motor when the latter is being driven by the road wheels, as in coasting down a hill with the ignition, or fuel, entirely cut off. Evidently, Dr. Hard got the thing confused in his own mind, and several other subscribers have already called attention to the matter. On anything but very stiff grades, however, it is customary with the general run of drivers not to drop from the high gear when coasting, the foot-brake being relied upon to supply whatever retarding effect is required in excess of that provided by the motor.

#### FOUR-CYCLING OF TWO-CYCLE MOTORS.

Editor THE AUTOMOBILE:

[1,284.]—I have a three-cylinder two-cycle boat engine which has developed a peculiar tendency to "four-cycle"—that is, for the explosions in each cylinder to occur on every other instead of on every down stroke. I had never heard of this phenomenon until I experienced it with my motor, but several friends tell me that it is a well-known effect, which never has been explained satisfactorily. This seems unreasonable, because if a thing cannot be explained or is not understood, it would appear impossible to rectify the fault it may occasion, yet I am not altogether prepared to believe that the engine in question must continue in its erratic working, for until recently it operated perfectly. The four-cycling occurs chiefly at high speeds and seems especially prone to occur at high speeds under light loads, as when the engine races through the propeller being lifted out of the water in a rough sea. The motor is an ordinary three-port type, the product of an amateur builder, but it possesses no "freak" elements in its design and has given a great deal of good service. Any information you can give on the subject, and especially anything that will directly help the situation with which I am confronted, will be appreciated.

Sandusky, O.

C. E. WATKINS.

It is a fact that at one period in the development of two-cycle motors there was a good deal said about their mysterious "four-cycling" under some conditions, and, for anything that we would be able to prove to the contrary, it is entirely possible that some of the factors in this phenomenon may be unascertained. Nevertheless, we know positively that in a majority of such cases of "four-cycling" it is due to a comparatively simple set of causes, the existence of which must readily appear from a consideration of the functioning of a two-cycle motor. In these, to begin with, unless they are of unusual type, the displacement of the exhaust gases subsequent to each power stroke is effected almost wholly by the incoming charge, so that no more exhaust goes out than charge comes in. The result of this is that under

extreme throttled conditions, usually coincident with light load, there is an enormous retention of exhaust gases, with which only a small percentage of fresh charge is intermixed. Consequently, if this condition is made still more unfavorable to correct operation by some derangement of the mixture, ignition, which perhaps occurs none too readily anyway under the circumstances, may fail altogether. However, as the motor continues to turn over, a portion of a charge thus left unexploded is in due time exhausted as though it had exploded, with the simultaneous access of another increment of fresh mixture. This may improve the cylinder contents to the point of ignitability, and, as long as the condition persists, the motor will thus fire on alternate strokes—"four-cycling." From all of which you will see that carbureter trouble is implied—probably some maladjustment calculated to set up the peculiar balance necessary to produce the effect you note. We shall be interested to know how you make out, and to hear from others who may have had experiences along this line.

**GEAR RATIOS OF A 45-HORSEPOWER CAR.**

Editor THE AUTOMOBILE:

[1,285.]—Referring to letter No. 1,251, of "Letters Interesting and Instructive," in your current number, is your reply correct? My impression is that the gear ratio in the bevel geared drive is either 3 to 1 or 2 1-2 to 1, this being optional, and the former being the one that is put in unless the other is specially specified.

The additional reduction in the gearcase of the Pierce-Arrow a few years ago was 1 to 2 for the intermediate, 1 to 3:54 for the low, and 1 to 4:56 for the reverse.

Taking the ratio of 3 to 1 in the rear axle, we would have the following ratios between the engine and the hind wheels:

- On high gear..... 3 to 1
- On intermediate gear..... 6 to 1
- On low gear.....10:62 to 1
- On reverse .....13:68 to 1

and without being positive, my impression is that their present car is not very different from this. In lower powered cars three to one is quite usual in the rear axle, and doubling this for intermediate, and again doubling for low is, I think, quite customary. An improvement on this is to raise the speed on the intermediate so as to get about 3 to 1 on high, 5 to 1 on intermediate, and 12 to 1 on low. The design of the sliding gear transmission is such that of necessity the reverse must be somewhat lower in speed than the low speed ahead. "GASOLINE SAL."

New York.

Probably the makers misunderstood our question when supplying the information, as what you state concerning the gear ratio is correct for the average car. We will let the makers answer.

**HOW MANY DROPS OF OIL PER MINUTE?**

Editor THE AUTOMOBILE:

[1,286.]—Please let me know, through "Letters Interesting and Instructive," how many drops of oil per minute each cylinder of my double opposed 4 9-16 by 5-inch horizontal engine should have. Portsmouth, O. SUBSCRIBER.

This is a matter that can only be determined exactly by experimenting a little, as different motors of the same make will frequently differ in this respect. Try 18 to 20 drops per minute for each, in order to be certain of having sufficient. If there is much smoke in evidence, cut the quantity down until it ceases to appear. Note the quantity of oil in the crankcase before beginning the experiment, and if no sign of smoke appears with the rate given above, run the motor under average normal load for 15 minutes steadily. Then examine the quantity of oil left in the crankcase, and, if unduly diminished, or increased, regulate the supply accordingly. A well-designed motor of this size, in good condition, should run smoothly on 10-12 drops per cylinder per minute, but it is better to go over, rather than under, the quantity, and it is quite a general practise with drivers to feed all the oil possible short of causing smoke. This is not a particularly economical procedure, but as the quantity of lubricating oil required to keep the average modern car in good running order is small under ordinarily favorable conditions, it is generally considered far better to use an excess.

**A FURTHER DISCUSSION OF MOTOR EFFICIENCY.**

Editor THE AUTOMOBILE:

[1,287.]—In your reply to Mr. Frost (1,206) and also to Mr. Pierson's statements (1,235) you claim that the power and efficiency of a gas engine are increased by lengthening the stroke. In regard to the power, I agree with you that there is an increase by lengthening the stroke, but there is not the same gain as obtained by increasing the bore for the same piston displacement increase.

Now as to the efficiency. Efficiency, in the first place, is the ratio of the heat converted into mechanical work to the total amount which enters the engine. Of course, the efficiency depends on the expansion of the charge, as stated by Mr. Pierson, but also on the heat loss to cylinder wall. Therefore, the most efficient motor is the one which not only gives the largest expansion or piston displacement for a given volume of charge, but also the one that does this with the least cylinder wall area. These two requirements cannot be fulfilled by a long stroke motor (i.e., a larger stroke than bore), but can be had with a short stroke motor (larger bore than stroke) of the proper proportions.

You also state that short-stroke automobile motors exhaust at terminal pressure as high as forty or fifty pounds, while stationary motors of good design get as low as ten or fifteen pounds terminal pressure. The utilization of the difference in pressure mentioned makes for greater efficiency, and is brought about directly by the stroke. Now this conveys the impression that the motor efficiency is greater with long-stroke, low terminal exhaust motors. Whereas, if the same expansion or piston displacement (with the same charge) were used on a larger bore than stroke motor, the efficiency would still be greater, even though the terminal pressure were higher (due to less cylinder wall heat loss), as reduction of terminal pressure by larger cylinder wall area will not increase efficiency, but lower it. The average stationary motor is also cooler.

We have all noticed the increase in motors using valves direct in the head, also the gain in power, flexibility and efficiency at slow and medium speed over the old style T-shaped chamber.

The gain in this type of motor is on account of a spherical combustion chamber, with reduced cylinder wall heat loss and charge reduction through heating on the suction stroke, as they have less cylinder wall area for a given volume. Now, if there is quite a noticeable gain in reduction of compression chamber area (for a given volume), should there not be a gain in reducing cylinder wall area for a given piston displacement as in using a larger bore than stroke motor in the proper proportions? The conclusions at which I have arrived are that the most efficient motor is the one with valves in the head, larger bore than stroke, high compression with fuel injection and expansion to nearly atmospheric.

With fuel injection, the compression can be increased to as high as five hundred pounds, as in the Diesel engine, without pre-ignition, as fuel is not injected until the end of the compression stroke or center. Again, if this feature should be applied to an automobile motor, it would be very beneficial when running on a throttle charge with the possibility of increased power for hill climbing, when desired, at slightly reduced efficiency. Of course, it is not necessary to increase the compression to five hundred pounds to gain in efficiency; one hundred and fifty pounds, or even one hundred and twenty-five would be a practical increase.

Philadelphia, Pa.

W. E. HAUPT.

**SUCCESSFUL EXPERIMENTS WITH DEAD CELLS.**

Editor THE AUTOMOBILE:

[1,288.]—Referring to Letter 1,233, in regard to rejuvenating dry cells and your answer thereto, we are not seeking to advertise our method of doing this, but, as a matter of "common knowledge" that certain alkaline solutions do as you say, there are others more adapted for still better results. As to cells being absolutely dead, twelve of them would not move a volt-ammeter, and for the same reason three of them are known to have been cast aside five years ago. It will be remembered, though, that whatever the age, the zinc must be in good condition. And when thus thoroughly treated, which requires but a few minutes, and at a cost of a few cents, it is certainly without a doubt profitable, for the additional period of activity will exceed more than half the original life. SELFE & WHITEFORD.

Darlington, Md.

**HOW TO RENEW TOP LININGS.**

Editor THE AUTOMOBILE:

[1,289.]—I notice you want an answer to inquiry No. 1,208. I had a customer bring me a repair job of that kind, and it puzzled me some before I thought of a scheme to remedy it. I bought a can of dull black "Jap-A-Lac," thinned this out with turpentine, and gave the cloth lining one coat of the same, covering the surface all over, let that dry and gave a second. This made it look almost as good as new. I hope this will help Mr. Fay out.

Corsicana, Texas.

CLARENCE THOMAS (Auto Doctor).

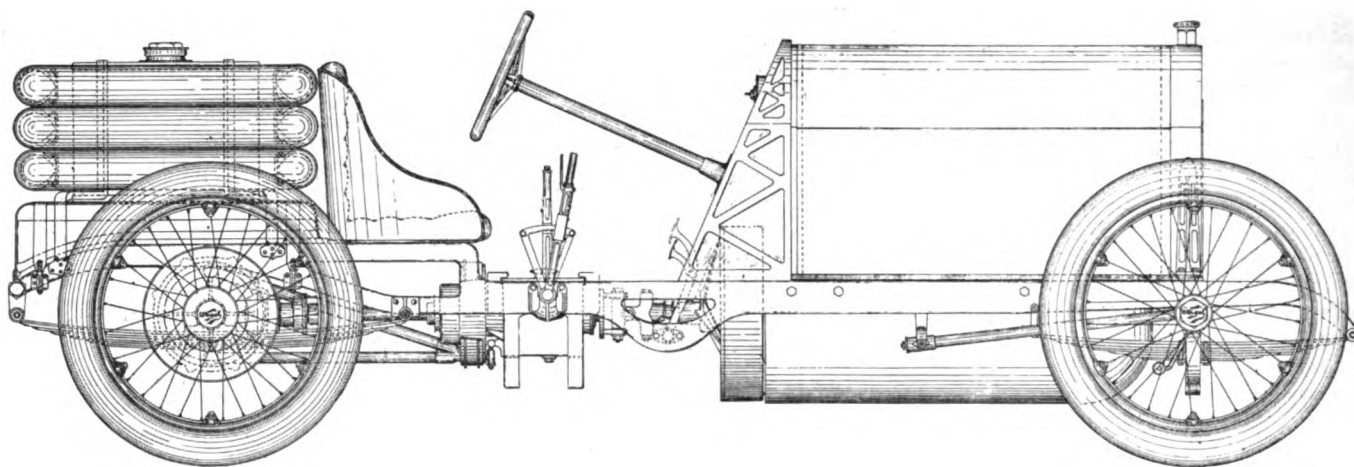

Side Elevation of 1908 Weigel Racing Car, Which Will Compete in the French Grand Prix.

## ABOUT BRITISH CONTESTANTS FOR THE GRAND PRIX RACE

LONDON, March 20.—The number of British firms who are to try their fortune at Dieppe in July is now finally reduced to two. There is no prospect of the Napiers competing on account of the detachable wheel dispute, while nothing has been heard of the Ariel cars, of which the first was shown at last Olympia. With regard to the actual entries, the Austin cars are still under construction, but will probably be on the road by the beginning of April. The engines have six-cylinders 127 mm. by 140 mm., and the gearbox is provided with four speeds, the third being direct drive, with the fourth geared exceptionally high to enable fast work to be done on favorable grades. Two of the cars have chain transmission, the third and also the spare car having live axles. Although this is the first appearance of the Austin in road racing events, its designers have had long experience and before the formation of the present concern, made the Wolseley racers of 1905 and 1906.

The Weigel cars made their first appearance in last year's Grand Prix, and though they did not meet with much success, owing mainly to the type of detachable rims employed, they attracted much attention on account of the fact that nothing but parts of the standard 40-horsepower touring car were used. The engines were two four-cylinder units coupled together.

This year, however, a special car has been designed throughout and it is particularly remarkable for the lowness of the

center of gravity. The engine has four cylinders 155 mm. bore and 175 mm. stroke, the four cylinders being cast in one piece. The valves are of unusually large size and are set to open directly into the combustion chamber at an angle of 45 degrees to the vertical. They are operated by a camshaft running above the cylinders. The pistons are of cast steel of very light section and the connecting rod bearings are of phosphor bronze with white metal linings. As regards lubrication the oil is forced by a pump through jets directly below each crank and the spray effectually lubricates the parts without excess of oil being able to reach the combustion chamber. The oil drains back to a pump at the front of the crankcase from which the pump is supplied. Two ignitions are employed, high tension magneto for normal running and battery and coil as a standby. A cone clutch replaces the flat plate type employed last year, and a three-speed gearbox conveys the power to the rear live axle. The frame, of channel steel, is kept low down, except at the rear, where it sweeps up to give the clearance for the back axle and to provide a seat for the driver, who is in this way only 28 inches from the ground. Detachable rims are used and the spares can be conveniently arranged round the fuel tank. These cars are practically completed, and will be put through extensive trials at Brooklands track, before being tried out on official circuit at Dieppe.

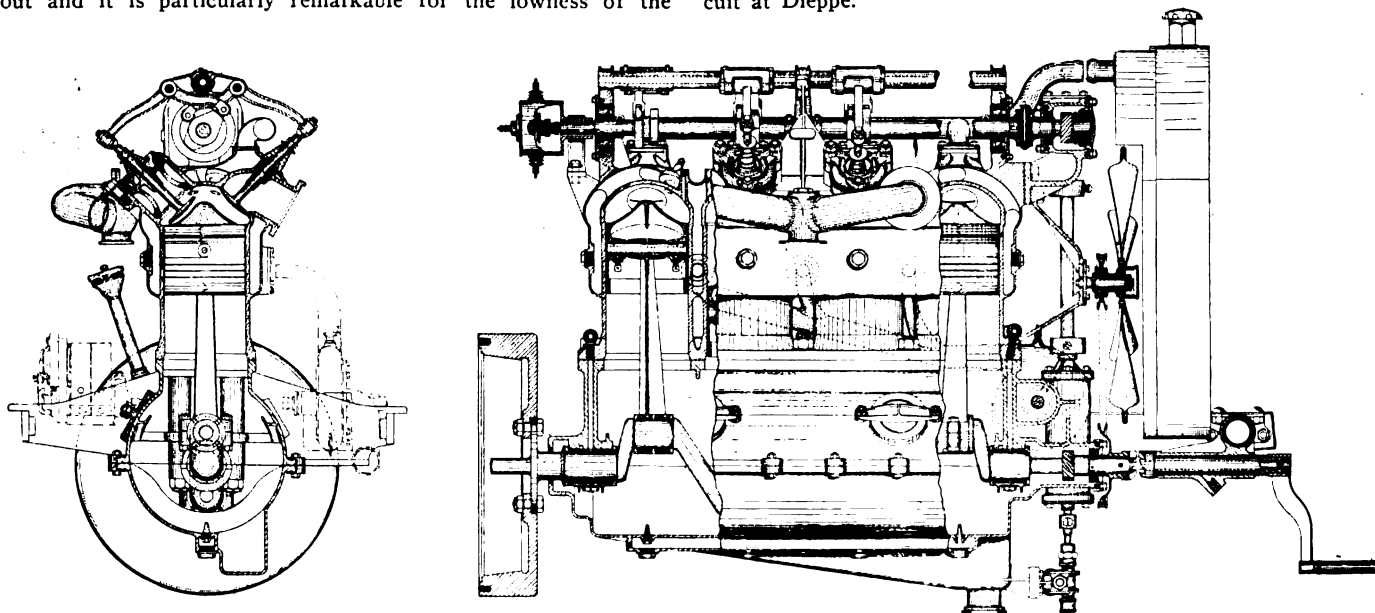

Sectional End and Side Views of Four-cylinder Motor Which Will Be the Power Equipment of the Weigel Racer.

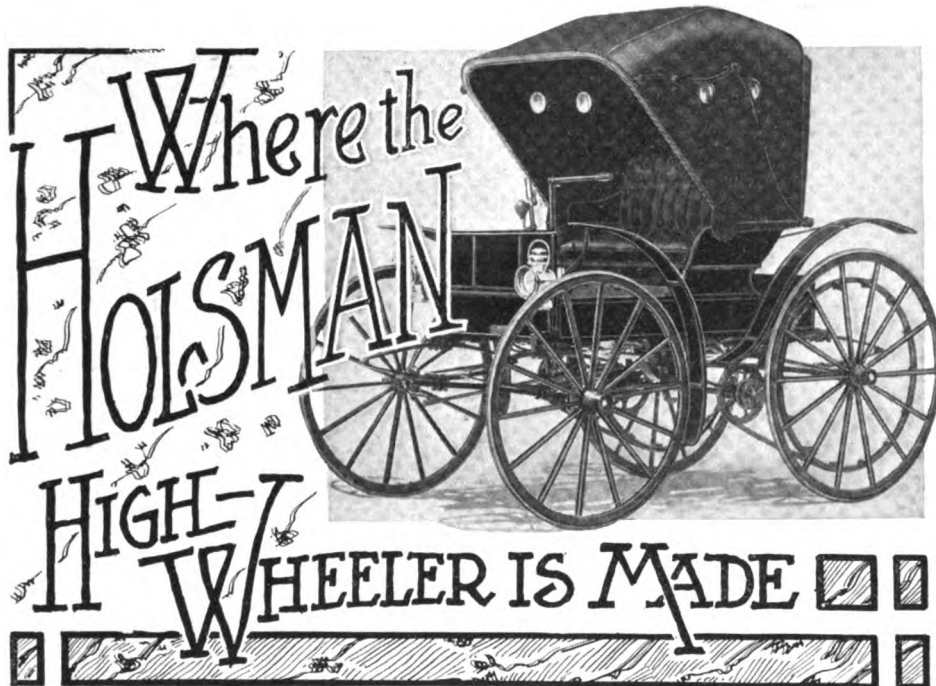

Model 5, the Latest Holsman Type of High-wheeled Auto.

THE owner of a Holsman car recently paid a visit to the factory of the Holsman Automobile Company at Chicago, for the purpose of investigating the new No. 5 model which the company is just putting on the market and has penned the following description of what he saw in that well-conducted plant:

"I expected to see a nice little runabout that would be serviceable and reasonable in price, and to say that I was agreeably surprised is putting it very mildly. I think this latest creation of their skilled mechanics will not be equaled for a long time to come. The lines on which it is built are artistic in every sense of the word, and the finish of every part speaks of good workmanship and good material.

"After arriving at Chicago, I first visited the Holsman general offices. These occupy the entire south end of the fourth floor of the Monadnock building. This building is said to be the largest office building in the world. Enough people go and come from this building every day to populate a city. I found this department of the Holsman Automobile Company a veritable bee-hive of business, and the whole place seemed alive with activity. After being most cordially received and shown the greatest consideration, I was given a letter admitting me to their factory. This document, I found, not only admitted me to their factory, but brought me the kindest attention from everyone in this great and busy place, which I understand is the largest producer in the world of the carriage or buggy type of automobiles, that truly American product.

"After viewing the No. 5 machine referred to above, I was shown first the wonderful motor which, connected with the countershaft and stripped of all other parts, constitutes the entire power plant for the different models of their machines. I was also very generously provided with photographs of the interior of the factory, along with one of the motor and countershaft. I consider this the simplest, lightest and most skillful power transmission for automobiles that was ever designed. The superintendent assured me that this was the secret of making a light machine. He also assured me that a light machine is a durable one.

I believe this to be a fact, because it is in line with reason and common sense that extra weight in an automobile makes traction greater, uses more fuel and soon racks it to pieces.

"I then visited the machine shop on the first floor. Every inch of space in this wonderful machine shop is utilized with metal-working machinery. I believe this is the busiest place and can furnish a larger variety of noises than any other place I ever visited in my life. Here emery wheels by the dozens are spitting fire, blacksmiths are forging red-hot irons, automatic saws are slowly cutting through large shafts of steel, also a hundred lathes are turning, groaning and screeching with turning off long, beautiful curls of metal from the parts which are being shaped. Hundreds of busy men are grinding, polishing, boring and fitting as if their lives depended upon it. This wonderful place with its hundreds of peculiar noises and clatter goes steadily on, night and day, for the plant is running to the extreme limit of its capacity.

"The motor assembling department on the next floor is where the most skilled mechanics in this branch of the work assemble and fit to the one-thousandth of an inch the various articles of bronze, steel and iron which go to make up the motor.

"The vehicle assembling room, illustrated in one of the photographs, is a busy place indeed. Here scores of men take the parts made in the machine shop and fit them together into the completed vehicle. Every man seems to know just what to do and how to do it with the least possible expenditure of energy.

"After being shown through this department, I was next taken to the testing room. This is a separate building. In this place a large number of motors are running at the same time at the rate of 1,200 to 1,500 revolutions per minute. Each motor is driving a large fan, which represents a certain amount of horsepower. This place is so filled with the hum of motors, the whirl of fans and the whirling of air that one is reminded of a Kansas cyclone.

"The trimming room is on the top floor. Here the humming noise of the sewing machines is about all there is to be heard. In this department leather is cut, formed and stitched, the but-

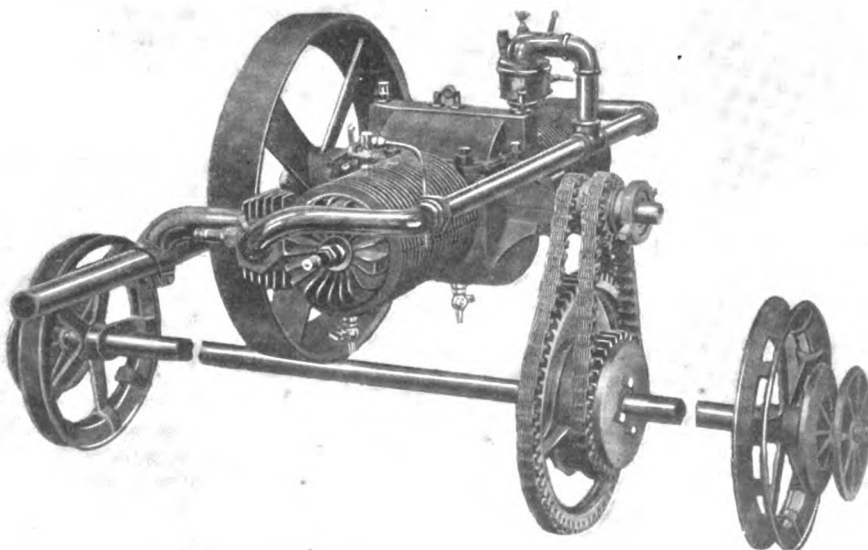

Holsman Motor and Countershaft, which Constitutes Power Plant and Drive.



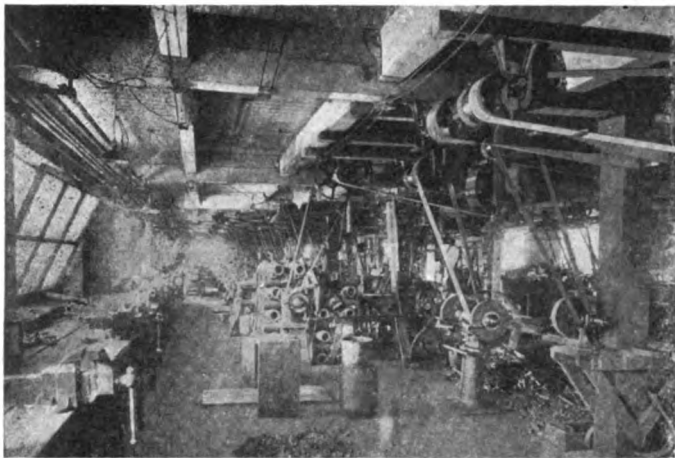

An Aisle in the Machine Shop of the Holsman Factory.

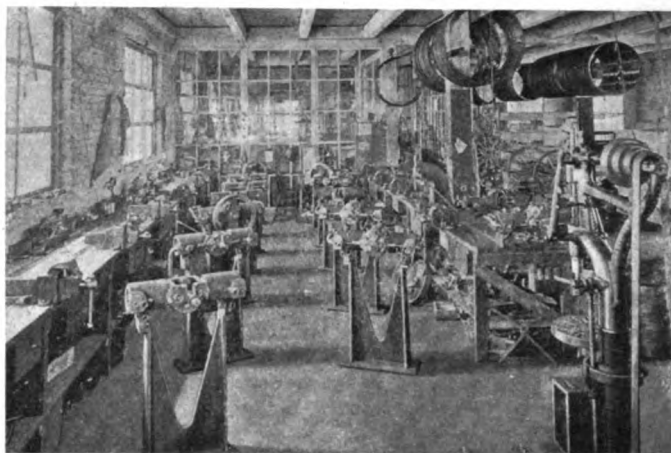

Corner in the Well-lighted Motor Assembly Room.

tons put into place, the finish put to artistic designs of backs and seats with the most wonderful skill. Here common everyday articles such as leather, wool, hair and cloth are fashioned into tops of perfect artistic beauty.

"The paint shop is also on this floor. A hundred or more vehicles are lined up and being painted. A blind man could easily tell when he was in this paint shop by the striking odor of turpentine and paints. These subtle artists are all plying their trade quietly but with great diligence. A person who has never seen it can never imagine the great change which takes place in the general appearance of an automobile after these tradesmen have given it their magic touch.

"We next visited the crating department. Here the men drive nails all day long, making the framework to protect the vehicles from damage during transit. The cars are taken apart, covered with cloth, and very carefully boxed. One vehicle was being prepared for shipment to India. A complete little house was being built for it and lined with waterproof roofing paper. Vehicles which go to this far-away country must be protected from moisture as well as from damage in transit. After crating is completed a large elevator drops the crates to the door of the cars which are waiting on the private track, and this track connects with every railroad and transportation line in the world. I have seen factories in all parts of the country, but I have never been so impressed with the system, workmanship, exactness of detail, wonderful management and large amount of work done, as in this up-to-date automobile factory, and that is saying a great deal, as it is a matter of common knowledge that the adoption of systematic methods of manufacturing has been carried to a much greater extent in the construction of American automobiles than is the case in almost any other line of industry which involves the use of such a vast amount of intricate and expensive metal-working machinery of every possible type."

### CONTINENTAL MOTOR WORKS TO ENLARGE.

MUSKEGON, MICH., March 30.—If evidence to support the claim that Michigan automobile interests felt the effect of the recent slump to a comparatively small extent were needed, the fact that the Continental Motor Manufacturing Company, of this city, has just let contracts for the erection of a new machine shop to measure 110 by 175 feet, to be completed by June 1 next, should be sufficient to show that the depression has not deterred this concern from going ahead with what appears to be much-needed expansion. The building is to be one story high, of the saw-tooth roof type, and of absolutely fireproof construction throughout. The present machine-tool equipment will be housed in the new building and extensive additions and improvements will be made in the shape of automatic machine tools.

A new motor-testing house, which is also fireproof, has just been added to the facilities of the Continental plant. It is claimed to be the largest and best-equipped of its kind in the country, as its permanent equipment provides a capacity for testing 50 motors at a time. The proposed improvement, *i. e.*, the large new machine shop, is the fourth addition that the Continental company has found necessary during the two years that it has been located in Muskegon, and the reason for making it just at this time is said to be because of the fact that orders now in hand are sufficient to keep the entire plant busy for many months.

The company is now making a very complete line of motors for touring cars, commercial vehicles and special taxicab and marine types, in addition to which it has been found necessary to largely increase their output owing to the demand for motors of the automobile type for various industrial applications, such as electric lighting, ditching machines, gang-plows, lawn-mowers, etc., owing to their compactness, and a large share of this demand has been filled by Continental motors.



The Department Where the Holsmans Are Assembled.

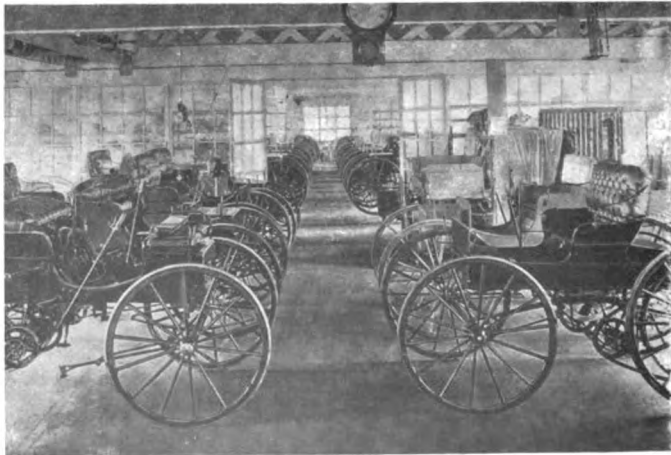

Where the Paint is Applied and the Finish Perfected.

## LONDONERS TAKE TO AUTOBUS VERY KINDLY

LONDON, March 23.—If any one had had the temerity to make the prophesy ten years ago, or even five, that to-day would see the streets of the world's metropolis full of machine-driven 'buses, he would have been derided. But then, no Britisher would have ever dreamed of making such an assertion. The old-time arks with their spavined and underfed motive power, which had to exert far more than the unit of energy which Watts has perpetuated, to get their load under way, were revered far too highly as a time-honored institution to be treated thus lightly. What would London be without its fleet of 'buses? Though the horse has been relegated to the limbo of forgotten things that the automobile has been responsible for banishing, and his place has been taken by a vehicle with a far greater capacity, still there seem to be more 'buses in London's streets to-day than ever there were.

From one point of view, the change has been merely one from flesh and blood to iron and steel—the smell of the horse and his stable have been bartered for the odor of petrol and lubricants, and the vast number of petrol-driven 'buses that now course the streets have given the London atmosphere another and a decidedly distinctive flavor. It had enough of its own before the passing of the horse, and whether this new one is the result of a chemical combination of exhaust gases from petrol motors with those that already existed, or is merely a blend in which the characteristic odor of half-baked petroleum products is uppermost, is a question for the connoisseur to decide. Certain it is that the question is one that has agitated London and Londoners not a little. As a matter of fact, at one time it appeared as if an ultimatum would be issued by the authorities that either the smell or the 'buses would have to go.

It is a most peculiar thing about the average London dweller that he never asked to have the atmosphere cleared of any of the many and sundry half-burnt products of combustion from other sources that continually fill it, nor could he distinguish any particular source of noise that afflicted his hearing unduly among the many that comprise the hum and roar of London

streets until the advent of the petrol 'buses. Then it suddenly became apparent that the smoke from the exhaust of hundreds of big cars and the clash of their sliding gears were things not to be grouped in the same class with similar annoyances, and were, consequently, not to be tolerated.

Like every other innovation, the petrol 'bus had to fight its way into favor, and the rapidity with which it has done this is quite in keeping with the advance that it marks over its predecessor, for the Londoner has already come to accept the power-driven 'bus and regard it as a hallowed institution, native to the soil—much as he did the trio of straining horses and the mountain of creaking, swaying carriage work they pulled. There are now some seven to eight hundred motor 'buses in London, of which more than 600 are owned and operated by two large companies, the London General and the Vanguard. Like everything else, the motor 'bus was



A View of the Strand, Showing the Passing of the Horse 'Bus.

made the plaything of the stock speculator in its earlier days and, as a result, the Vanguard Company is overburdened with watered shares. Though the statement has been contradicted and denied as often as it has been announced in the press, it is known definitely that there is a movement afoot to amalgamate these two concerns into one corporation—a step that cannot fail to have a far-reaching and beneficial effect upon London's surface transport facilities, which are not of the best by any means.

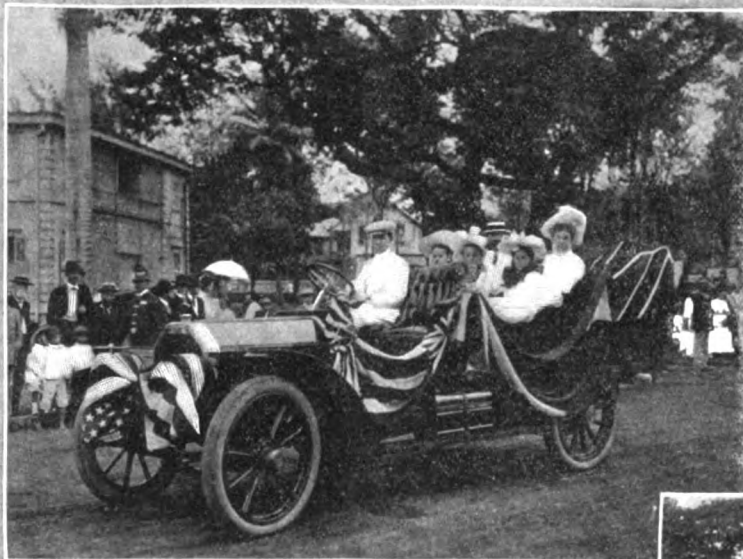

Governor W. F. Frear of Hawaii leading the  
**Floral Parade**  
 Washington's Birthday  
 at  
 Honolulu H.I.





## TEN YEARS AGO FIRST WINTON WAS SOLD IN CLEVELAND

TEN years ago—to be exact, Tuesday, March 24, 1898—the Winton Motor Carriage Company made its first sale of a motor carriage, and the sale was traceable directly to an advertisement.

On that morning, Robert Allison, a mechanical engineer of Port Carbon, Pa., called at the little Winton factory and asked if he might see one of the "horseless carriages" which had been advertised. "Surely," responded Mr. Winton. "And I'll give you a ride in it, too, if you like."

Mr. Winton's suggestion pleased the caller immensely, for he had just visited two places in other States where "horseless carriages" were said to be in process of making, but had been received coldly and denied even a peep at the mysterious machines.

The Winton car was scrutinized critically for an hour or more. Then a journey several miles across town was undertaken, one or two stops being made while Mr. Allison called out mechanical engineers, friends of his, to pass judgment upon the machine. Early in the afternoon, being assured that a machine could be ready for shipment to him within a week, Mr. Allison signed

his name to an order and became the first American purchaser of an American-made, standard-model, self-propelled road wagon.

H. C. Sargeant, of Westfield, N. J., also a mechanical engineer, visited the plant that same afternoon and was surprised to find there his friend, Allison. Mr. Sargeant absorbed a great deal of Allison's enthusiasm and followed his lead, buying car No. 2. Thus on its first day of actual business, the Winton Company sold two machines.

The first batch of cars consisted of four machines, one of which Mr. Winton himself used. Only one of the four now remained, and this car was bought by John Moody, a manufacturer of Hamilton, Ont. This sale, made two days after the Allison and Sargeant sales, completed the output and gave the struggling Winton Company the moral and financial encouragement which ultimately resulted in the establishment of the greatest exclusive automobile factory in the world. Mr. Allison's car was shipped from Cleveland promptly on April 1. A week later the vehicles for Messrs. Sargeant and Moody were on the railroad cars.

## AUTOMOBILE HAS BECOME A NECESSITY IN EVERYDAY LIFE

"WE are reaping the reward of faith," said Benjamin Briscoe, in discussing the present marked revival in the automobile business. The Maxwell factory has not laid off a man all season, but, on the contrary, has been working to capacity during the past few months of business depression, while other factories either closed down entirely or worked a short force.

"That we not only did not curtail our output, but actually increased it over our original schedule, was due to our unbounded faith in the stability of the country and of the automobile industry—at least that part of it engaged in the production of moderate priced cars—and that we have been unable to accumulate a single car against the heavy spring demand is proof that our optimism was justified. Ordinarily, we plan to produce several hundred cars over the delivery demands in the months from November to March, but this season we have been hard pressed to keep up with current orders.

"At the time when the breaking of a few banks threw some of our competitors into a fit, and pessimism was rife, I looked the situation over and came to the conclusion that that was our time to make a ten-strike. I was certain of the ultimate recovery of trade and I believed the period of depression would be short-lived. On those grounds we determined to push work in

all four plants so as to have Maxwell cars ready for delivery early—a most important advantage to be gained over those of our competitors who were standing idle or undecided as to what to do. Then I figured that, as almost all other factories had canceled orders for material—indicating that they would turn out only about half as many cars as we had previously estimated they would—there would be still more room—and more demand—for Maxwells. So we increased our output 25 per cent.

"Our faith is being rewarded in a way that surpasses our fondest hopes. Our sales since August 1 show an increase of 42 per cent. over those of the same period last year and those of January, February and March surpass last year by 50 per cent. When I say sales, I mean deliveries—not merely orders. Seems as if this showing gives the lie to the too general supposition that the automobile industry is to suffer more than other branches of commerce from the temporary depression. For my part I predict that the total business of 1908 will exceed that of 1907 by greater or as great a margin as that of 1907 was in excess of the year before. In other words, I believe the automobile has become a necessity in the everyday life of every successful business and professional man, and if any additional evidence of this were necessary the constantly increasing sales should be sufficient."

## FARMERS GENERALLY ARE NOT HOSTILE TO AUTOMOBILES

IT has become the fashion among some writers and not a few autoists to credit the farmer with a feeling of animosity toward the automobile. In the New York to Paris race some of the drivers complained that the "peasants," as they called them, charged exorbitant rates for the assistance rendered the snow-bound machines.

G. B. Sharpe, publicity manager for the Studebaker, stated in a recent interview that his own experience with the Studebaker Army dispatch car that made the run from New York to Fort Leavenworth, Kansas, most of the way over the same route, would lead him to an entirely different conclusion regarding the farmer's attitude. Said Mr. Sharpe:

"The farmers helped us dig through snowdrifts and brought their horses out to assist us through drifted roads where or-

dinarily a farmer would not think of asking his horses to go, and, considering the service rendered, I do not believe their charges were exorbitant. Furthermore many of them exhibited an enthusiasm that was, to say the least, cheering to our tired drivers and crew. All along the line our drivers reported the same kind of treatment, and nowhere were they more enthusiastically welcomed than in the great farming State of Kansas. I believe that almost invariably if the motorist will regard the farmer as a friend instead of an enemy and accord him the gentlemanly treatment which is his due the farmer will be only too glad to meet the motorist on the same footing. The selfishness of the few who thought that superior speed and power gave them the earth and all that was on it, has been the mainspring of the farmer's dislike for the automobilists as a class."





Two Ships of the Desert

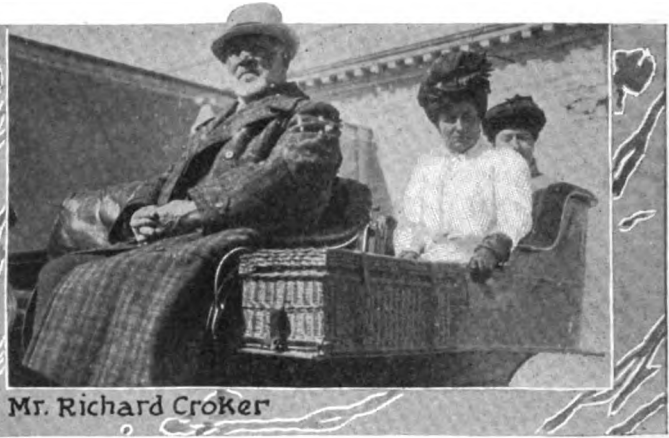

Mr. Richard Croker

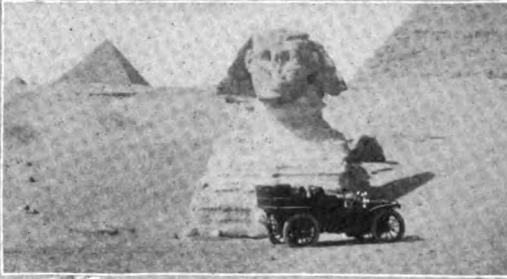

First Car ever on this spot

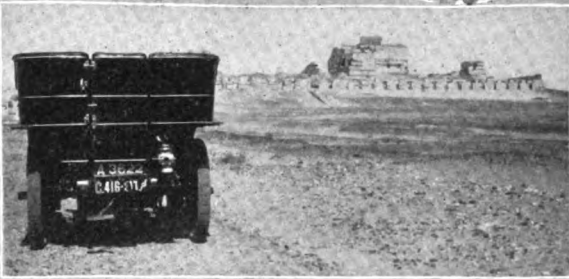

Abandoned Castle



Pacha Hassan. H.H. Prince Aziz

MR. GLIDDEN IN THE LAND OF THE PHARAOHS.

February 27, Mr. and Mrs. Charles J. Glidden completed their tour of the land of the Pharaohs, which was started on February 13. The roads of Egypt are limited but good, the longest continuous drive being 60 miles, from a point on the desert, east of Cairo, through that city to the Pyramids.

On completing his tour of Egypt, Mr. Glidden, having obtained permission from the Sultan of Turkey, proceeded to Palestine. He cables from Jerusalem that it was impossible for him to land his Napier car at Joppa, and he was obliged to proceed farther north to the port of Haifa. From that point he drove by way of Athlit, Caesarea and Joppa to Jerusalem. It was the first automobile ever seen on that route, and caused much excitement among the natives. Mr. Glidden's total mileage to March 18, on his world's tour, was 43,137 in 37 countries visited. From Jerusalem Mr. Glidden drives his car to the sea of Galilee, returning to Haifa, and sends his car from there by train to Damascus, 176 miles, driving to several places out of Damascus, and finally reaching Beirut via Balbec.

The next country visited will be Greece, followed by Montenegro, Dalmatia, Croatia, to Trieste, crossing the Dolomites, and reaching Paris early in May and London about May 15.



An Egyptian Village



A Native Chauffeur

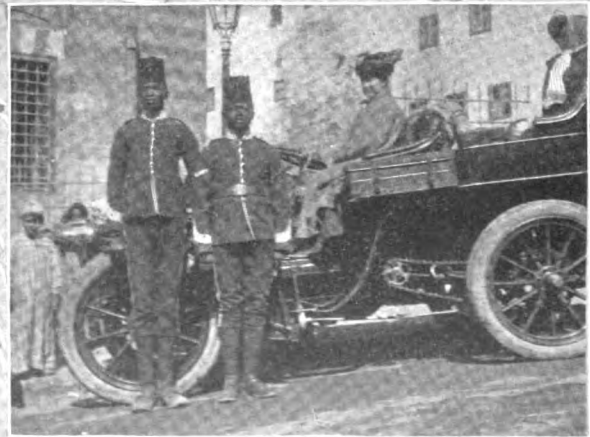

Soudan Police

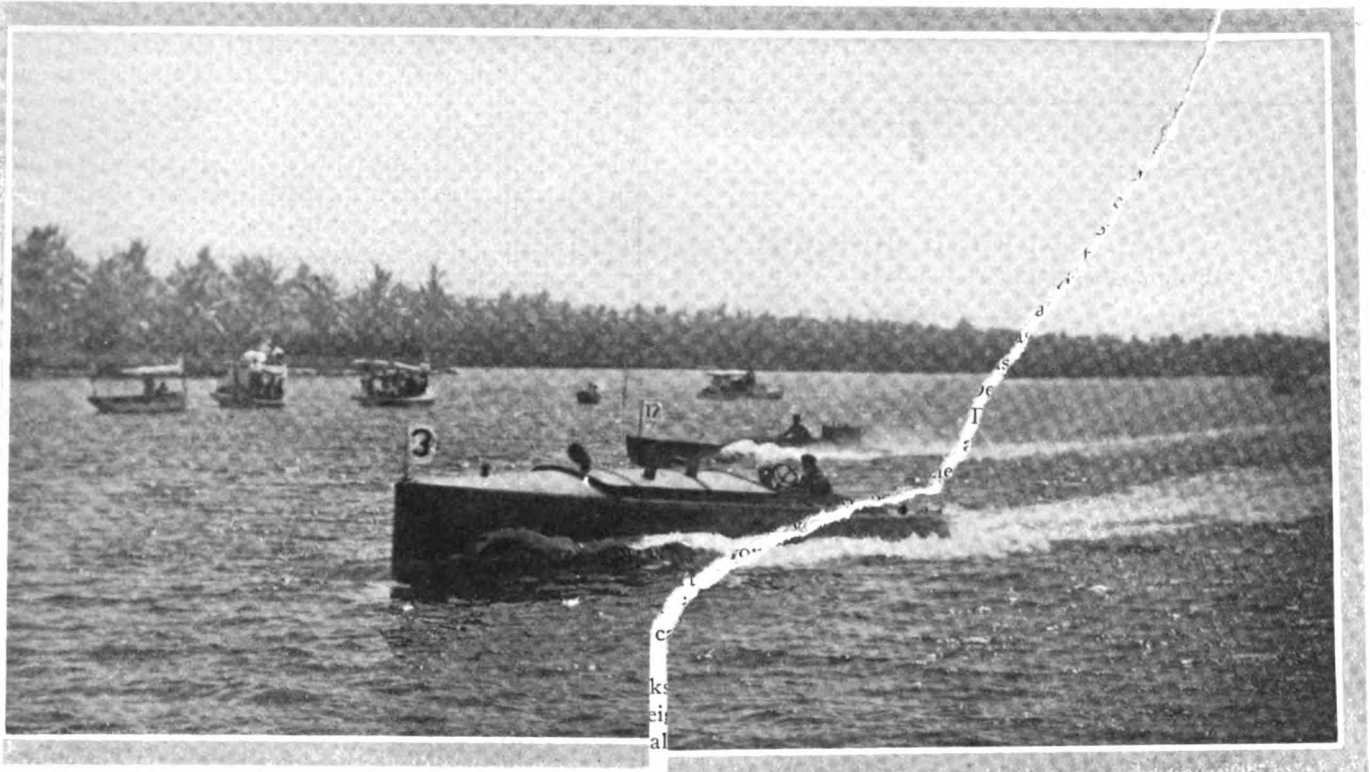

"Dixie" Leading "General" in 41-2-Knot Race at Palm Beach, Fla.—Finish Was Two Seconds Apart.

**THE PALM BEACH MOTOR BOAT RACES.**

**H**OW broad in scope has become the work being done for motorists by the American Automobile Association is illustrated by the information for tourists now in hand and being compiled. Speaking of the work of the touring board, and how the fact of the A. A. A. being truly national in character enabled it to do what none other can, Chairman Hower says:

"It must be remembered that the touring board, besides the chairman and Secretary Lewis, has ninety members, located in as many sections of the country. During the past year, the local clubs of the American Automobile Association have been laying out routes, radiating from their respective cities, copies of which have been forwarded to the touring board office in Buffalo and by the touring board arranged in files, from which copies can be readily made on the application of members. This information could not be gathered by an individual, nor by an individual club, at any cost, but only by a body such as the American Automobile Association, by reason of the clubs affiliated with it, numbering now 126.

**A** home. While they were rearing its walls of sea-shells and mortar, Michelangelo was building the famous dome of St. Peter's in Rome. Back across the Atlantic, the forefathers of Washington and Lincoln were living in England, unmindful of the unborn descendants who were to make their names imperishably illustrious, but in spite of their labors the religious peace that they sought came not. Instead came Spanish adventurers, who interfered with their form of worship and at length butchered them. From 1565 to 1580 the house was used as a home for the monks, chauffeur and the chauffeur's personal expenses. These arrangements can be made at the touring board offices in Buffalo, or at the secretary's office in New York, and the car selected will be at the place in Europe designated, at the time named. The touring board files contain information of all description, such as import duties, car and driver's licenses, together with routes, descriptions and conditions of roads. Arrangements have been made with the American Express Company covering the shipment of automobiles to any foreign port at a rate lower than can be obtained by any one other than A. A. A. members. All of this assistance is absolutely free to members."

**E. P. CHALFANT TAKES CHARGE OF LICENSED ASSOCIATION**

**A**T a meeting of the executive committee of the Association of Licensed Automobile Manufacturers, at the New York City, Tuesday, March 21, specially called to take action in the

**THE OLDEST HOUSE IN THE UNITED STATES.**

A celebrated French author, referring to a very aged person, remarked that death seemed to have forgotten him and passed him by. In like manner it may be said that the furies of fire, frost and blistering sun seem to have forgotten an old house that stands in St. Augustine, Fla. It is the oldest house in the United States—built 345 years ago, in 1565—yet, with a new roof and new siding, it stands there to-day like a sturdy bit of the sixteenth century carried over into the twentieth. The house was built by French Huguenot emigrants, who came to a new world to seek the religious peace that they could not find at

mobile Manufacturers. Prior to entering the automobile field, Mr. Chalfant was assistant to the president and head of the sales department of the International Tire Company. His experience in the sales end of the industry dates back some fifteen years.

When seen after the meeting to-day Mr. Chalfant said: "I have been very much interested in the work and policies of the Association ever since I became a board member, nearly four years ago. Although I have not held an executive position, I have been in close touch with things relating to the Association and the Selden patent. The general policy inaugurated by the members of the Association will not be materially changed, and I believe that the near future will develop some interesting facts as the result of the close relationship that the members have with the Association."

**PEOPLE WHOSE OPINIONS ARE WORTH WHILE.**

**S. H. Mora, Mora Motor Car Co., Newark, N. Y.**—"We are firm believers in the six-cylinder proposition's future. Our agents seem to look at it as we do; for our orders are two to one for the 'sixes' as compared with the 'fours.' To my mind the aim of construction has been to attain flexibility equal to that of the steam car. Two cylinder cars supplanted 'one lungers' and the double cylinder gave way to the quadruple. So I believe that the 'six' will supplant the 'four' at the high price end of the business. Continuously applied power is an advantage not to be disputed. We have tried to produce as light a car as is consistent with strength and average power. We are satisfied with the progress we are making; for the engine and transmission of our 'six' weigh but 15 pounds more than those of our 'four'."

**H. O. Smith, Premier Motor Car Co., Indianapolis.**—"Our trade opening in Indianapolis scored a far greater success than ever the most sanguine expected. The selling results of the week showed fully three cars purchased to every one sold in any week in March 1907, or, putting it in another way, the sales were equal to the business done in any three weeks in March last year. The carnival was on a more elaborate scale than the initial one last season. Among the features were various competitions of the obstacle order to show the control of the cars. We also had a successful hill climb. I was much disappointed in not getting our Premier to Savannah, but we could not spare our factory men to look after it. We shall have two or three cars in the Glidden Tour."

**G. V. Rogers, Mitchell Motor Car Co., Racine Junction, Wis.**—"The expansion of our factory is continuing. We have broken ground for three new concrete buildings which will bring our total floor space up to 14 acres. One is 600 by 130 feet for a paint shop; a second, 130 by 160 feet, for a shipping department; and the third, 100 by 130 feet, an addition to our main machine shop. We are making great preparations for our big reunion of agents on August 27, 28, and 29. The entertainments will run from prize fights up through the whole gamut of motor car functions. We will start day and night shifts on April 1. Business in the West is booming."

**W. H. Van Dervoort, Moline Automobile Co., Moline, Ill.**—"The selling season in the West has opened a month earlier than last. The demands for cars are coming to us in larger quantities than in March, 1907. This is especially true of the small towns, which everywhere have had a brisk trade. I have an idea that this is explained by the fact that the second hand cars and machines taken in exchange have been dumped into the big cities and have interfered more with the sale of new cars than have the few exchanges in the little places."

**R. M. Owen, of R. M. Owen & Co., Selling Agents of the Reo.**—"Things are going smoothly enough at the factory at Lansing to admit of Mr. Olds continuing his sojourn at Florida to this late spring date. Speaking as selling agent I can say that actual sales of Reos to date are ahead of last year and you must not forget how big a year 1907 was for the Reo."

**C. F. Wyckoff, of Wyckoff, Church & Partridge, Eastern Selling Agents for the Stearns.**—"I have just returned from a visit to the factory at Cleveland, where I found the production progressing satisfactorily. While West I stopped at Chicago. The agent there reported that Stearns sales were double those of last year to date."

**Milton J. Budlong, President Packard Motor Car Co., of New York.**—"I am a newcomer to the Packard fold. I am amazed at the vogue the car has. Close to 1,000 cars of the 1908 output have already been shipped from the factory."

**A. A. A. RACING BOARD IN SESSION.**

A meeting of the A. A. A. Racing Board is to-day in session at the Association's headquarters, 437 Fifth avenue, New York City. Rules and the Vanderbilt race are under discussion.

**PULLMAN IS PHILA.—SAVANNAH WINNER.**

PHILADELPHIA, March 30.—At a meeting of the Contest committee of the Quaker City Motor Club, last Saturday afternoon, the protest of the Pullman people against the awarding of the honors in the recent race to Savannah to the Studebaker was sustained. The latter car arrived at the finish first by nearly 24 hours and came in for a great reception, while the Pullman was almost lost in the shuffle. The crew of the latter, however, proved that they had adhered to the course laid out before the start, while the Studebaker people, who were miles behind, left the course and cut across country to dodge the bad going; that they had lived up to the agreed-upon conditions regarding drivers staying with their cars, while the Studebaker sent in relays and shipped the worn-out man ahead by rail to get him in shape for the next relay; that their observer had stayed with the car, while the Studebaker observer was absent from the car on several occasions. In view of this testimony, which the Studebakerites failed to successfully meet, the committee spent little time in coming to a decision.

**Banquet at York to the Pullmanites.**

YORK, PA., April 1.—Over three hundred persons attended a banquet in this city on Saturday night, which was given by the employees of the York Motor Car Company in honor of Paul Gillette, Newark; G. W. Daley, Philadelphia; Robert Morton, York; the crew of the Pullman automobile, which won the race from Philadelphia to Savannah, and James A. Kline, general manager of the York Motor Car Company. Many of the most prominent autoists from this section of the country were present, and the function was enjoyed by all who participated. The toastmaster was W. W. Williams.

The banquet tables were arranged in a letter "P," and the dining hall was decorated with large American flags and bunting. During the evening Manager Kline read a telegram he received from the Quaker City Motor Club, which stated that the Pullman car had been awarded the race. Mr. Kline then announced that the York Motor Car Company had challenged the manufacturers of the Studebaker car to race one of their 40-horsepower machines any distance up to 1,000 miles for a purse of \$5,000.

Preceding the banquet was an automobile parade, in which twenty-five of the Pullman models took part. There was a band, and each automobile was decorated. The Pullman "Swamp Angel," which won the race to Savannah, headed the procession. It was driven by Robert Morton, and, besides him, contained General Manager James A. Kline and M. H. Schuler.

**E. V. CO. TO BE LEGALLY WOUND UP.**

HARTFORD, Conn., March 30.—It is reported that foreclosure proceedings will be instituted in the United States Circuit Court for the district of New Jersey this week, with a view to legally winding up the affairs of the defunct Electric Vehicle Company, as it is said to be the desire of the bondholders of the company to dispose of it as a going concern to the Packard Motor Car Company of Detroit. The situation is somewhat complicated by the efforts of the Electric Storage Battery Company of Philadelphia, the largest single stockholder, which holds \$6,500,000 of the paper, to reorganize the company, though its attorneys would give no information on this point.

When called upon to confirm the report of the foreclosure proceedings, the attorneys for the receiver in New Jersey, Lindabury, Depue & Falks, stated that they knew nothing of it and that an application to continue the manufacture and sale of cars from parts and material on hand, had been made to the court and granted on Monday last. Receiver Nuckols has been in Chicago during the past week, closing the branch in that city on April 1. The New York branch is to be closed on April 25. It is reputed to be the intention of the Packard company to devote the Hartford plant to the manufacture of commercial trucks, the motors of which will be built in Detroit.

## CHICAGO'S CARNIVAL IN SUCCESSFUL PROGRESS

CHICAGO, March 30.—On a most pretentious scale the spring carnival of the Chicago Automobile Trade Association was inaugurated Saturday night, and to-day there is every indication that the affair will be a huge success. Every one of the stores along the row has been artistically decorated for the occasion with ferns and other potted plants; some of them have added outside decorations, and all along the street there is a carnival spirit that cannot help but enthuse dealers as well as prospective customers. In fact, every one of the sixty and more members of the trade association has entered into the spirit of the affair, and, with their shoulders to the wheel, they are pushing with a unanimity that cannot help but bring success.

A census taken of the row Saturday shows there are fifty-two representatives of car concerns participating, while there are thirteen tire concerns and eleven houses handling accessories. This, it is calculated, means the carnival is a million-dollar show, for the total list of the 216 different models on view reaches \$900,000, while the tire and accessory exhibits easily add the other \$100,000. This census also disclosed the fact that there are seventy-six different makes of cars on exhibition, of which number all are American-made except two, the Renault and Isotta. In this lot are several motor buggies and commercial propositions, while the motor cycle is well represented.

The carnival was opened with an illuminated parade Saturday night, and it was the grandest affair of its kind ever witnessed in Chicago. The weather man, though, had a grouch. The judges, Ira M. Cobe, John W. McKinnon, and George C. Greenburg, counted ninety-two cars in line when the parade went past the reviewing stand for the first time. All of them were not dec-

orated, however, it being Chairman Paulman's idea to alternate an illuminated, then an undecorated car, in order that the spectators might better study the beauties of the illuminated display. It was no easy task picking the winners—there were so many beautiful designs. There were three prizes, but, in addition, it was decided that there should be ten given honorable mention. The judges' decisions were as follows:

First prize.—Thomas Flyer roadster, driven by C. A. Coey.  
 Second prize.—White steamer, driven by Miss Mildred Plew.  
 Third prize.—Woods electric, driven by Paul Frank.  
 Those to get honorable mention were as follows:  
 Apperson, driven by J. F. Gunther.  
 Ford roadster, driven by Robert Bartel.  
 Vesta battery, a Thomas-Detroit, driven by C. E. Gregory.  
 De Luxe, driven by E. E. Read.  
 Stoddard-Dayton, driven by Marshal Rapp.  
 Gearless, driven by H. W. Russell.  
 Peerless, driven by John Bonschein.  
 Pierce-Arrow, driven by Paul Hoffman.  
 Pennsylvania tires, Mason car, driven by W. D. Rockwell.  
 Indian motorcycle tri-car, ridden by John T. Fisher.

The awarding of first prize to Coey met with the approval of most of the critics, for the Thomas was most elaborately decorated. Coey, being president of the Aeronautique Club of Chicago, seized the opportunity to advertise the sky pilots by using an airship for his main idea. Simplicity and beauty were aimed at in the White steamer, and the judges hesitated a long time before they gave the first award to Coey. Miss Mildred Plew drove the steamer, a big White car, and was dressed in white. Carl Metzger, on the Woods electric, won third prize, his car being very expensively decorated.

### SITUATION AT ALBANY IS COMPLICATED.

ALBANY, N. Y., March 31.—With the failure of the revised motor vehicle law bill to make its appearance in either house, although it was practically drawn and all but a few details agreed upon prior to the break between the New York State Automobile Association and the Automobile Club of America, there has come a decided activity in separate amendments to the existing automobile law. Those bills already in show an inclination to move, and others are being introduced.

At the session of the Senate last evening Senator Grady of the Sixteenth Kings district introduced a bill amending the motor vehicle law so as to include in the requirements for a licensed or registered chauffeur a minimum age limit of 18 years, and also the furnishing of a bond in the penal sum of \$2,000 for the payment of any injury, loss, or damage resulting either to person or property by reason of the unskilful or negligent management or operation of a motor vehicle by said registered chauffeur. The bill was referred to the committee on internal affairs.

### KISSEL KAR CUTS CALIFORNIA RECORDS.

News comes from Los Angeles of another victory for the Kissel Kar on the Pacific coast. After breaking the Los Angeles to Daggett record, it followed up this creditable feat the very next day by setting up new figures for a run from Los Angeles to Victorville, a distance of 105 miles in 3 hours and 50 minutes, and also from Los Angeles to San Bernardino, covering 65 miles in 2 hours 5 minutes.

### DAYTON DEALERS ORGANIZE TO HOLD SHOW.

DAYTON, O., March 30.—At a meeting of the local trade, held here late last week, the Dayton Automobile Dealers' Association was formed, G. G. Peckham being elected president, and A. M. Dodds, secretary-treasurer. Plans are already under way for the holding of the first automobile show this city ever seen. It will take place at Armory Hall, April 20-26 next.

### MARYLAND WILL NOW HAVE ROADS.

ANNAPOLIS, Md., March 30.—The Good Roads bill has finally passed the Legislature. It is now a law, and has been signed by Governor Crothers. The bill was passed without a dissenting vote, after an agreement had been reached with reference to the provision relating to the taxing of railroad franchises on turnpikes. In the shape it has finally passed the bill appears to satisfy every element of both parties, and the most delighted of all are the automobile clubs of Washington and the State of Maryland, including the Automobile Club of Maryland. The work the bill calls for guarantees to Maryland the best roads in the country, and in the future tourists between New York, Philadelphia, Baltimore and Washington will not have to travel through a sea of mud in passing through Maryland.

In its present form it includes the best features of the bill that Benson presented, and the men who were instrumental in bringing about the result contend that it means that \$5,000,000 will be spent in this State within the next few years in building good roads and that not one cent of this amount will be taken directly from the masses. The tangle, which for a while threatened the bill, was finally straightened out by an amendment. The bill then went through both houses a-flying. The amendment regarded the United Railways franchises and turnpikes, by which the right of the city to collect the park tax in Baltimore from the company over those highways is guaranteed.

### APPERSON WILL MAKE VANDERBILT ENTRY.

CHICAGO, March 30.—Edgar Apperson has announced his intention of entering an Apperson Jackrabbit in the next Vanderbilt Cup race under the colors of the Chicago Automobile Club. "If the race for the Vanderbilt Cup," said he, "is held in the vicinity of New York or at Savannah, I will enter a car in that event." This is believed here to be the first positive announcement of any American maker that he will be represented in the great American classic race on the road.



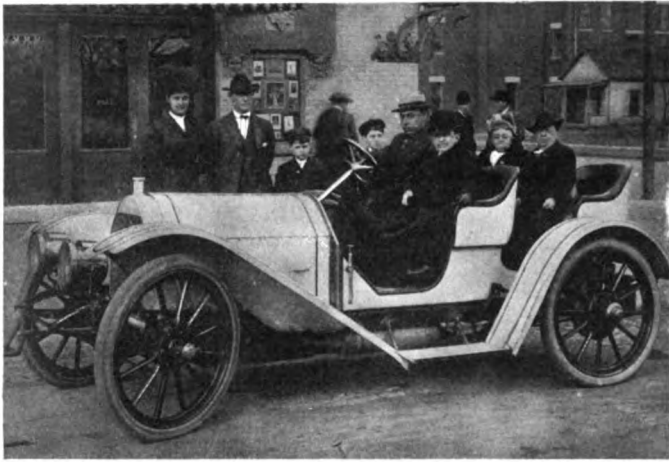

Midgets Touring the West in Their Imperial Roadster.

Count and Countess (nee Mrs. Tom Thumb) Magri and Baron Magri on their arrival at Topeka, Kan., in their Imperial car, in which they are traveling the country.

**SEASON'S PACKARD OUTPUT FINISHED EARLY.**

DETROIT, March 30.—In accordance with its long-established custom of making early deliveries of its product, the Packard Motor Car Company is busy to the full capacity of its immense plant, getting out the last 400 cars of its season's output. Already a thousand 1908 Packard "Thirties" have been delivered to purchasers, and the 2,000 men at work in the different departments of the factory, which covers a floor space of eleven acres, are now turning out cars at a rate which will probably complete the annual program of production on schedule time. Last season the final car was finished a month ahead of the scheduled time of delivery, and the company is anxious to be well advanced at the close of this season.

There is no long period of inactivity between seasons in the Packard factory. The production of cars of successive models is so arranged that, as one department completes its work for 1908, it picks up that for 1909. Thus the immense body-building department, which makes all of the Packard bodies, including the limousines and landaulets, naturally completes its output for the season before the assembling, painting and other finishing departments, and is one of the first to start on new work. The company's new power plant now being in operation, giving a total of 2,500 horsepower, the factory is in much better shape than ever to produce cars expeditiously.

**INDIANA'S AUTO WEEK A SUCCESS.**

INDIANAPOLIS, March 30.—Taken from both a commercial and an educational standpoint, the annual automobile show given here last week under the auspices of the Indianapolis Automobile Trade Association, was distinctly a success. Sales aggregating fully \$400,000 were made during the week, a comparatively low estimate considering the fact that about 200 automobiles were sold. Throughout the week there was the greatest harmony between the dealers and manufacturers. All of the salesrooms were elaborately decorated, and several concerns gave neat souvenirs or arranged for some special entertainment. At the last minute the parade to have been given Monday was postponed until Wednesday afternoon, but it suffered nothing from the delay.

Tuesday several hundred persons witnessed the four-tenths of a mile climbing contest on Michigan hill near the city, which followed a short parade on downtown streets by the contestants. The timing was accomplished by a very unique device, the contesting car breaking a thread which started a stopped watch which was stopped by electricity as a second thread was broken at the top of the hill. Rules of the American Automobile Association were observed in the events. The summary follows:

**Cars Listing at \$1,000 or Under.**

- 1. Buick, Buick-Losey Co., W. B. Peterson..... :48 3-5
- 2. Ford, Gibson Auto Co., Frank Menthorn..... :56

**Cars Listing from \$1,000 to \$1,800.**

- 1. Overland, H. T. Hearsey Vehicle Co., C. P. Brockaway.. :50 3-5
- 2. Stoddard-Dayton, Fisher Automobile Co., Guy Simmons. :51 2-5

**Cars Listing from \$1,800 to \$2,740.**

- 1. Stoddard-Dayton, Fisher Automobile Co., Howard Hodson :38 4-5
- 2. Thomas, Indiana Automobile Co., L. E. Finch..... :40 4-5

**Cars Listing from \$2,750 to \$3,500.**

- 1. Stoddard-Dayton, Fisher Automobile Co., Howard Hodson :37 2-5
- 2. Thomas, Indiana Automobile Co., L. E. Finch..... :40 4-5

**Cars Listing Above \$3,500.**

- 1. Stoddard-Dayton, Fisher Automobile Co., Howard Hodson :39
- 2. National, Fisher Automobile Co., Thomas Kincaid..... :39 2-5

It is estimated that fully 100,000 persons from all parts of Indiana saw the parade held Wednesday afternoon, when 226 automobiles, of which 175 were entered by local dealers and manufacturers, were shown. The others were driven by individual owners, and one of the interesting features was the first attempt in the city to show commercial vehicles on a large scale.

The week closed with a supper and smoker at the Grand Hotel beginning at 10:30 o'clock Saturday night, at which there was also a lively vaudeville entertainment. About 250 members of the trade, and their friends, attended.

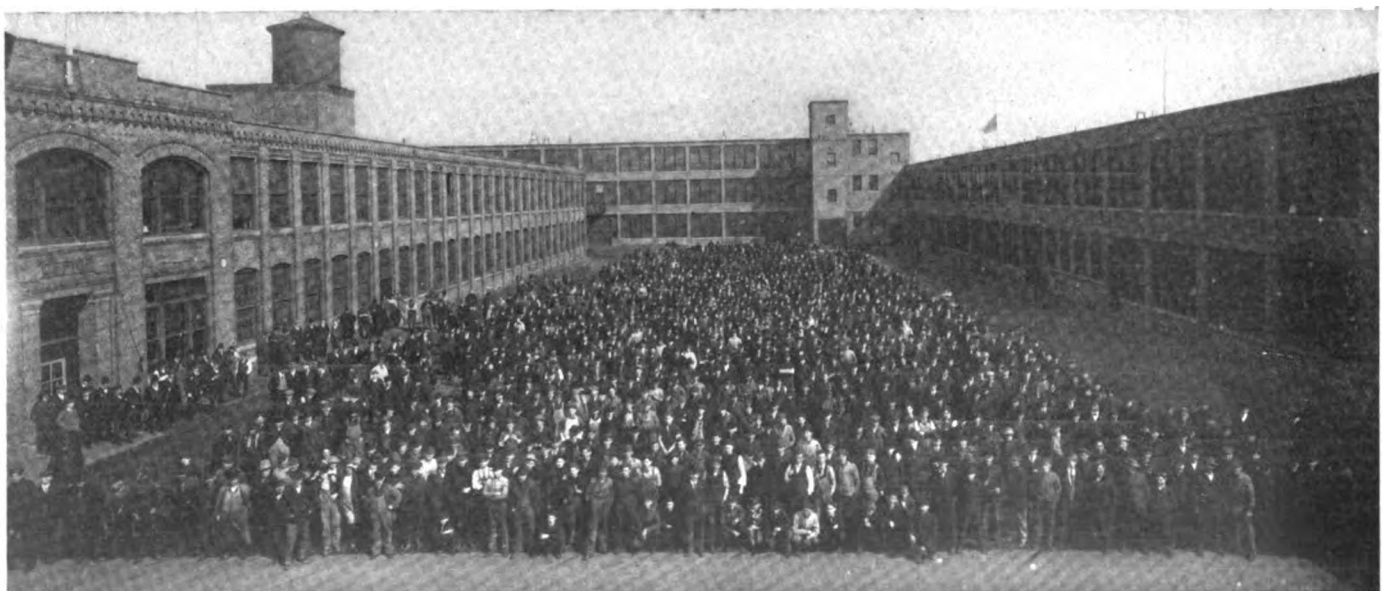

Employees of the Packard Motor Car Company in One of the Courtyards of the Company's Plant at Detroit.

## BRIEF ITEMS OF NEWS AND TRADE MISCELLANY

The Continental Caoutchouc Company has offered \$1,000 in prizes to the finishers in top places in the Briarcliff race whose cars are fitted with Continental tires.

The Atlantic Motor Car Company, agents for the Stoddard-Dayton, with headquarters at 1776 Broadway, are the latest to expand, having been compelled to lease the adjoining store, thus doubling the size of their salesroom.

The Michelin Tire Company has confirmed its offer of cash prizes to successful contenders in the Briarcliff race equipped with its product. The prizes for entrants are: \$500 for first, \$350 second, \$200 third, \$150 fourth, \$75 fifth, with like prizes for the drivers of the cars.

By way of winding up the affairs of the bankrupt Dragon Motor Car Company, successor to the Dragon Automobile Company, the receivers will offer in April at public auction at the factory in Philadelphia the assets of the company. Included among them are said to be some seventy Dragon touring car chassis.

It is interesting to note that while pessimistic reports occasionally crop out regarding the automobile trade in general the actual facts of the case belie the opinion of the pessimists. The Bosch Magneto Company reports that it sold during the week ending March 14, 4,970 magnetos and that it is over 1,000 machines behind in its orders.

Unlike the Vanderbilt Cup course, there are not many places on the Briarcliff course from which an unobstructed view of the course can be obtained. A grand stand is being erected at the East View turn, which gives a clear view of the course for a half mile in each direction. Information concerning tickets for this stand can be had of Koenig Brothers, Tarrytown, N. Y.

Evidences of the scale on which the recently reorganized Wayne Automobile Company, Detroit, Mich., is planning to turn out cars are to be seen in its order for \$200,000 worth of machinery, most of it designed by W. E. Flanders, general manager, who, with President B. F. Everett, have been given carte blanche by Messrs. Palms and Book, the backers of the concern.

The New Departure Manufacturing Company, Bristol, Conn., recently received a strong testimonial letter from Apperson Brothers, of Kokomo, Ind., regarding the very satisfactory performance of the New Departure annular ball-bearings, which were used in the winning Apperson at Savannah, Ga. These bearings will form part of the regular equipment of all the Apperson cars turned out during 1908.

Cartier, Chapman & Company, Ludington, Mich., report that business is better than it ever has been in the history of the concern. They are the makers of the Breeze windshields, and the improvements recently added to their line have created a demand that is bringing them orders from all parts of the country. The company states that it has not had occasion to lay off a single mechanic or lose an hour's time throughout the past winter.

"According to figures compiled by the American Motor Car Manufacturers' Association, it is apparent that enthusiasm has been rekindled with the coming of spring," says F. P. Brand, president of the Imperial Motor Car Company. "The registrations at Albany have been unusually heavy this month—751 cars having been registered in New York State during the first three weeks of March. I believe 1908 will witness the breaking of all automobile sales records."

An incident which marks an epoch in the automobile industry was the shipment of the first car from the new Maxwell factory at Newcastle, Ind., last week. From now, each Maxwell plant will devote itself exclusively to the manufacture of but one model in its entirety—the light runabout being made at Pawtucket, R. I., the four-cylinder, 28-horsepower touring car at Tarrytown, and the two-cylinder Model "H" roadster and touring car at Newcastle, Ind.

"The recent Boston show brought us the best business we have ever had from an automobile show," said B. A. Becker of the Elmore Manufacturing Company, Clyde, O. "The public would be very much surprised to learn how well-posted auto purchasers are becoming on the question of the two-cycle cars," he added. "The simplicity of this type of motor, together with the low cost of maintenance, are such strong points that the Elmore factory is unable to keep up with the demand."

The touring bureau of the White Company, Cleveland, O., has just compiled the sixth in the series of White route books. The new issue covers the route from Philadelphia west over the National highway, as far as Springfield, O., and then southward as far as Savannah. It gives the first definite data published on the roads of Kentucky, Tennessee, Alabama and Georgia, with directions for following the National highway through Maryland, Pennsylvania, West Virginia and Ohio, which are given for the first time with accuracy and in detail. No less than 1,800 miles of road are covered, beside which there are numerous illustrations, a double-page map and articles descriptive of the route. Copies may be obtained gratis on application to the White Company or any of its numerous branches, or to the White touring bureau at 1402 Broadway, New York.

### RECENT BUSINESS CHANGES.

The R. E. Hardy Company, manufacturers of Sta-Rite spark plugs, has moved from 86 Watts street to 25 West Forty-second street, New York City.

The Auto Tire Company, of Kansas City, Mo., has removed to its new location, 605-607 Fifteenth street, that city, where a new tire repair plant, said to be one of the most complete in the West, has been installed. Victor Nelson is the proprietor, and the concern carries a full line of Morgan & Wright tires, for which it is general agent.

John H. MacAlman, for the past two years manager of the Columbia Motor Vehicle Company, Boston, has taken a lease of the Columbia salesroom and repair shop on Stanhope street, that city,

and will continue business under his own name. He will continue to handle Columbia cars, having been assured of a supply from the Hartford factory, and may later take on some other line in addition. Mr. MacAlman is president of the Boston Automobile Dealers' Association and one of the best known tradesmen in the New England States.

### NEW AGENCIES ESTABLISHED.

The French Manufacturing Company, Waterbury, Conn., who make a full line of seamless tubing for automobile use, are now turning their attention to lighting tubing, of which they will make a specialty.

The Curtis-Hawkins Company, the Motor Mart, Boston, has just secured the agency of the Speedwell cars for that territory. The Speedwell is a comparatively newcomer and is made in Dayton, O.

George H. Lowe has just closed a contract with the makers of the Imperial Roadster, the Imperial Motor Car Company, of Williamsport, Pa., to handle it in Boston and vicinity during the coming season.

The Butte Novelty Works, Butte, Mont., have just taken on the Franklin line for 1908. They also handle the White steamer. The Warren Automobile Garage, Warren, Pa., which also handles the Franklin, is now owned entirely by D. M. Jackson, the firm formerly being Jackson & Cross. It is said that applications for the Franklin sales agency have been received at the rate of eight per day since March 1.

### PERSONAL TRADE MENTION.

General Manager S. A. Miles, of the N. A. A. M., who is touring abroad, has completed a run of over 400 miles in Wales.

J. H. Baer, designer of the Buffalo carbureter, has been on a trip visiting the Eastern trade. The National Sales Corporation, 296 Broadway, New York, is the factory sales agent for this make of carbureter.

W. B. Hurlburt and C. R. Teaboldt, manager and secretary of the Garford Motor Car Company of New York, have been constant visitors at the factory at Elyria, pushing deliveries of Garford cars for the Eastern market. A large number of orders have been booked.

J. F. Somers, formerly with the automobile department of Brown, Thompson & Company, Hartford, Conn., has been engaged as manager of the Post & Lester Company's retail branch store, situated at 175 Asylum street, in the same city, and has already taken up his new duties.

INFORMATION FOR AUTO USERS

**"Uphrow-Cushion" Springs.**—This is an ingenious and simple device recently placed on the market by the Thomas Spring Works, Canisteo, N. Y., and is designed to prevent the breakage of leaf-springs by "upthrow." As will be noted from the accompanying illustration, the complete device consists of a special form of coiled spring, adapted to be clamped



UPTHROW CUSHION SPRINGS.

on the axle and strapped to the frame, though two styles are made permitting them to be attached either under, or over, the axle. Four comprise a set, in order to protect each one of the springs of the car. Perfect freedom of spring action is allowed on the downward movement, but the Uphrow-cushion comes into play as soon as the upward thrust of the body rises above the normal and the coil springs then begin to resist, softly but surely. The straps shown are designed to be attached to a forged hanger bolted to the frame inside near the bottom. These straps are drawn taut and buckled after the car has its normal load aboard, and after that do not need to be disturbed.

**Swinehart Detachable Solids.**—Great pains and study have been devoted to the perfection of detachable devices for pneumatic tires, but up to recently this has not been the case with the solid tire for commercial use, though the loss of a tire means more to the owner of an automobile truck than it does to the autoist who drives for pleasure alone. To supply this

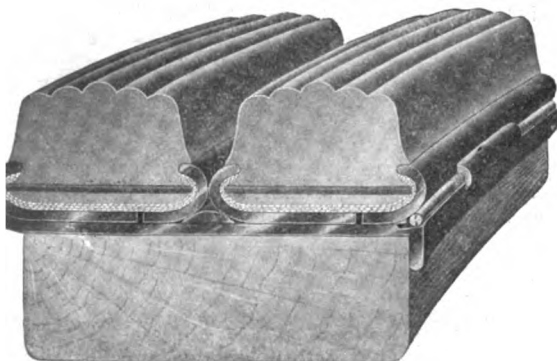

applied within twenty minutes, so that there need be no delay worth speaking of. The locking device not only secures the rim laterally, but it also wedges it tightly on to the retainer so that there can be no play between the rim and the rim retainer. The endless wire connected with the right and left-hand threaded turnbuckle can be loosened in less than half a minute; it can also be removed, reapplied and tightened up in about the same time. The method of mounting this new Swinehart rim and tire is clearly shown in the cut.

**Koehler's Universal Auto Spring.**—From the very start, auto makers have adopted the old-time carriage types of springs, and no attempt has been made to depart from these time-tried designs, although it has been apparent that the suspension of an automobile required something different. Hence, the shock-absorber. But this new device, which is made by the Universal Auto Spring Company, Broadway and Branch street, St. Louis, Mo., is complete in itself and requires no supplementary devices. As will be seen from the illustration, a section, of about 8 inches, is cut out of the center of the half-elliptic spring, or the lower

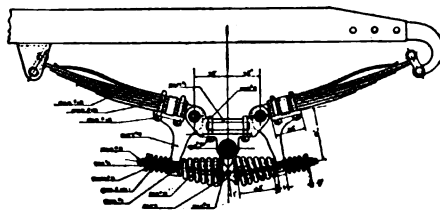

DETAILS KOEHLER'S UNIVERSAL SPRING.

member, where a full elliptic is used. A fulcrum bracket is then placed in the same relative position on the spring seat, as shown, directly over the axle, while fulcrumed to this bracket is a drop-forged steel arm, called the spring equalizer. To these equalizers, on the upper part, are fastened the ends of the quarter elliptic springs, and, on the lower ends, between the two equalizers, is placed a barrel-shaped compression spring, beside two coil-springs of smaller dimensions on the opposite side from the compression spring. The last-named spring is adjustable to fit the height of the body, the adjustment being made through the equalizer spring. This combination of balanced forces effectively prevents all shocks and jars from being transmitted to the body or mechanism of the car, as they are entirely absorbed in the springs.

**K-W Magneto.**—Though the K-W magneto has now been on the market less than two years, the makers—The K-W Ignition Company, 34 Power avenue, Cleveland, O., report that the demand for it is increasing so rapidly that they have become compelled to increase their facilities for manufacturing, and have also had to add to their working force. An improvement has been made in the friction drive used on this year's model of the magneto, the face of the friction wheel having been made twice as wide as formerly. It is built up of a number of rings of chrome-tanned leather, making it oil-proof, and according to the makers this type of friction wheel will give as positive a drive as a chain or gear. The K-W type of magneto occupies a unique position in the igni-

tion field, as it is the only one of its kind that does not have to be positively driven in order to give good service. It is intended principally as a substitute for the battery and is employed in connection with the usual vibrator coils. The current generated is known as a "sine wave" current, in contrast with the usual high peaked wave alternating current, thus making its output of a uniform value above a certain speed which permits of the operation of the magneto by means of a friction drive or belt, without interfering with the synchronism of the ignition sparking. The magneto is of the inductor alternator type, thus having no moving wires, or brushes, which make it extremely simple.

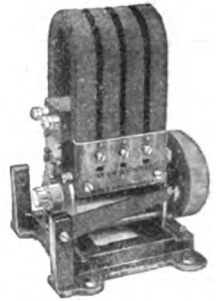

K-W MAGNETO.

**Oberdorfer Carbureter.**—This is a new representative of the concentric float carbureter, and is being made and marketed by the M. L. Oberdorfer Brass Company, Syracuse, N. Y. It is provided with central air-opening, auxiliary air-valve, and has usual adjustments for needle valve of the spray nozzle to regulate the flow of fuel from the float chamber. The method of adjusting the tension of the auxiliary air-valve spring is by means of a screw, as shown, and this, as well as the other adjustments, with the exception of the gasoline feed valve *B*, may be made from the outside without disturbing any other parts. To adjust *B*, the cover *B*<sub>3</sub> must be removed and the valve lifted out. The cone *B* can be driven up or down its stem, to increase or diminish the part of the stem *B*<sub>2</sub>, which bears on the top of the lever *B*<sub>4</sub>, arching over the upper part of the

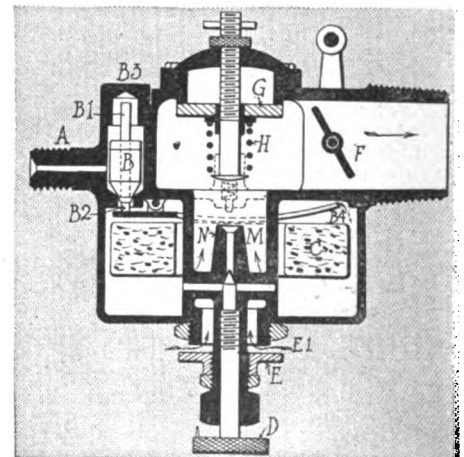

SECTIONAL VIEW OBERDORFER CARBURETER.

float *C*. The length of the arms of the lever *B*<sub>4</sub> is such that the rise and fall of the needle *B* is just half that of the float *C*. The normal air supply enters as shown by the arrows *E*<sub>1</sub>, the size of the opening being varied by raising, or lowering, the regulator *E* and locking it in place. The needle valve *D* does not rise to the tip of the nozzle *N*, thus retaining a small quantity of gasoline in the hollow between the tip and the opening of the nozzle, to facilitate starting. The auxiliary air-valve *G*, with its spring *H*, is of the conventional type, as is also the butterfly throttle *F*.

# THE AUTOMOBILE

NEW YORK'S automobile carnival is in full swing. In the elaborateness of the decorations, in the universality of the participation of the trade, in the co-operation of the entire Automobile Row district, in the general hurrah, in the interest this celebration of the tenth birthday of the motor car industry in this country has aroused, and in Tuesday night's monster parade, the carnival has surpassed in magnitude

and magnificence the fondest hopes of its promoters, the members of the New York Automobile Trade Association.

The two miles of Broadway from Forty-second to Eightieth street, comprising Manhattan's automobile row, is ablaze with flags and bunting. Not only is every building having to do with the industry decorated from cellar to roof, but the hotels, restaurants, saloons, and many shops have joined in making this carnival week a New York holiday so far as the hotel and motor car district of the city goes.

Along upper Broadway throngs parade the great thoroughfare rubber-necking at the decorations above and peering into the corridors below. The salesrooms and garages are ablaze with lights and gay with decorations. Demonstrators are at hand to answer questions and point out the particular features of the cars. All along the line there are reports of sales, consummated even thus early in the week and glad tidings of bright prospects ahead.

The dealers, however, have little time or inclination to talk of individual benefits derived. All have been fairly carried off their feet by the magnitude the carnival has assumed and the response New Yorkers have

given to their efforts. All are confident that the carnival will show results at once which will extend far into the season; to put it more truly and frankly, all rejoice in the conception and promotion of the celebration as a means of stirring up the motoring metropolis from its semi-lethargy and cynical pessimism to a realization of how very much alive the automobile is in New York. They are happy, too, at the successes Chicago and Indianapolis have scored through seizing so promptly their suggestion of a carnival and proving by prompt promotion the worth of the idea.

It is a revelation of the innate possibilities for enthusiasm and local patriotism the co-operation the carnival scheme has met with from the general New York public. Automobile Row furnishes an eye opener, indeed, of the extent of the local industry as emphasized by the fact that from Forty-eighth to Sixty-fifth street on both sides of Broadway there is an almost unbroken line of automobile trade establishments. The decorations pick them out. The spots between, occupied by many hotels, restaurants and saloons, are decorated, too, thus making the string of flags and bunting continuous along the route.

Below Forty-ninth street lies the hotel and restaurant district around Times square. This leads the building dressing with brave displays. Flags float from every window of the Times Building. Rector's, Shanley's, Churchill's and the Cadillac are smothered in bunting. The decoration fever is spreading and the professional decorators are as busy as bees adding red, white and blue to Broadway. Even as far down as the twen-



given to their efforts. All are confident that the carnival will show results at once which will extend far into the season; to put it more truly and frankly, all rejoice in the conception and promotion of the celebration as a means of stirring up the motoring metropolis from its semi-lethargy and cynical pessimism to a realization of how very much alive the automobile is in New York. They are happy, too, at the successes Chicago and Indianapolis have scored through seizing so promptly their suggestion of a carnival and proving by prompt promotion the worth of the idea.



King Clark in a Waltham.



Queen Joan in a Mora.



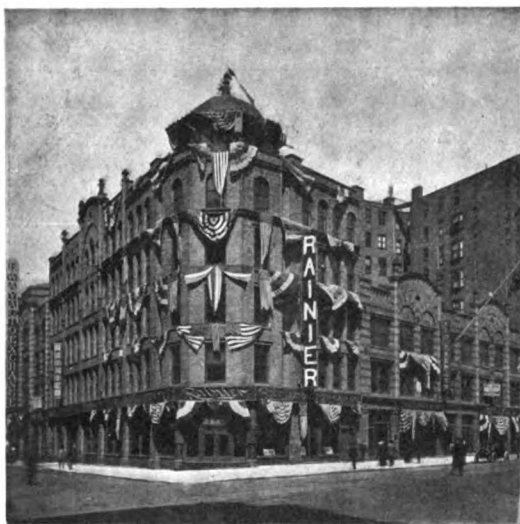

ties and thirties, Martin's, the Breslin and the Grand have hung out bunting and flags. Above Sixty-fifth street the automobile establishments are a bit more scattered. Here, though, the Belle-claire and other hotels have helped out in the decorations.

Automobile Row has many great garages and big buildings. None of their owners or tenants has been feazed by the expense or difficulty their size presents for decoration. Every one of the big establishments has been completely decorated from sidewalk to the roof. The great buildings occupied by the Palmer & Singer, Ford, Lozier, Rainier, Haynes, Southworth, Stearns, White, Panhard, Homan & Schultz, Corbin, and American Locomotive branches and agencies are ablaze with flags and bunting.

Father Knickerbocker, in a word, is doing himself proud during this his first automobile carnival week.

**'Twas a Most Convincing Parade.**

Automobilists Tuesday night gave to New York another great night celebration. To Father Knickerbocker's New Year's eve racket and his Election night hurrah must now be added the Automobile parade; for this annual spring opening carnival will doubtless be perpetuated. The automobile celebration stretched for nine miles. Along Broadway from Twenty-fifth to One Hundred and Tenth street, and on Fifth avenue from Twenty-fifth to Fifty-seventh street, crowds jammed the sidewalks on both sides. Allowing but 3,000 spectators to a block, the figures will reach 560,000 to view Tuesday night's parade. Such a demonstration of the magnitude of the industry, it is safe to say, this or no other country ever saw before.

The parade was a monster affair. In its broken form, slowing down in places and racing in others, it took 1 hour 40 minutes to pass the west side of the reviewing cars at Eighty-fourth

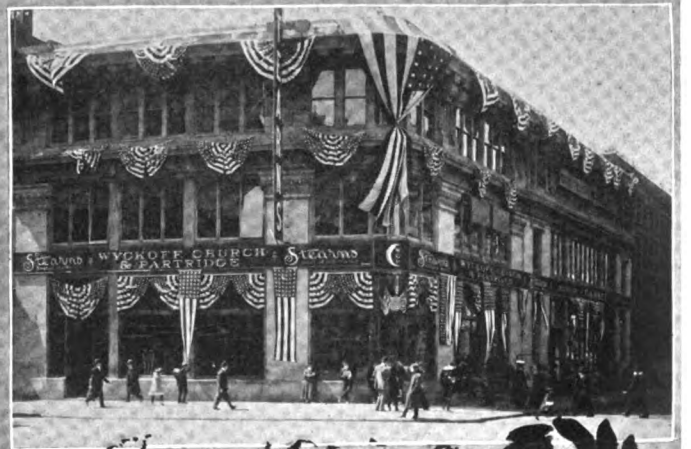

street. In solid order, after Grand Marshal R. G. Howell had waited for the ranks to close up, the procession was an hour in passing the judges. At its slowest gait, fourteen cars went by a minute and at a faster pace twenty-two were counted in the same time. This would indicate some 1,200 cars in line; in fact, the committee's conservative estimate put the total at about this number, distributed as follows: Ancient and racing cars, 100; dealers' division, 800; decorated cars, 50; commercial cars, 250. New York's biggest previous parade numbered less than 300 cars.

The four divisions formed in Fifty-seventh, Fifty-sixth, Fifty-fifth and Fifty-fourth streets, west of Broadway. They began to assemble after 6 o'clock, and at 8:35 the procession started down Broadway, its route taking it to Twenty-fifth street on that thoroughfare, then to Fifth avenue up to Fifty-seventh street, crossing over to Broadway and up to One Hundred and Tenth street and countermarch back to Columbus Circle, where it disbanded. Colored lights were burned on much of the route and along lower Broadway confetti was showered upon the spectators. New Yorkers, in a word, made a night racket of the parade, packing the restaurants until daybreak.

Features of the parade were too multitudinous to be catalogued in a single story, in which only comparatively few details can be touched upon. Inspector Schmittberger led the parade in a car trimmed with N. Y. A. C. emblems. He was followed by a squad of cycle cops, preceding Grand Marshal R. G. Howell in a Northern runabout, decked with flags and bearing his title in an electric frame. Mrs. Joan Newton Cunco, the Queen, came next in a six-cylinder Mora car, seated on a flower-decked throne, smothered in roses. Leonard K. Clark, the King, in a Waltham, followed, also on a throne.

The first division was made of a mixture of the old and the

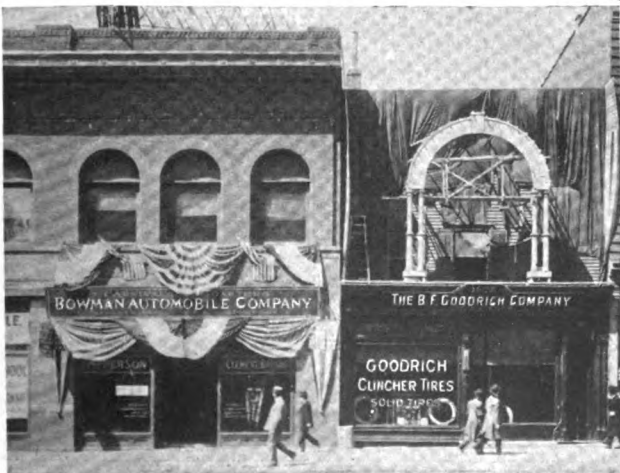

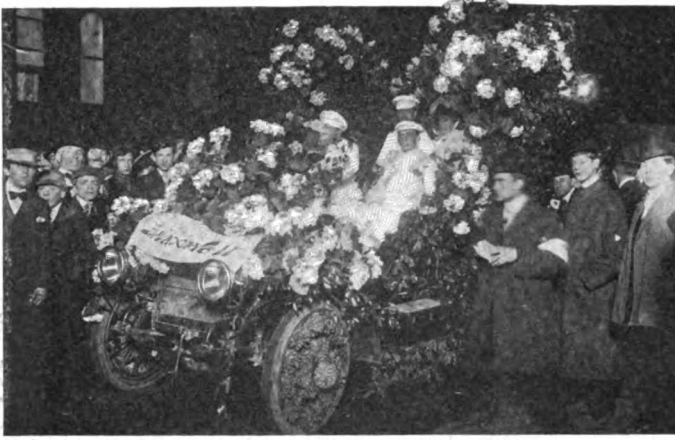

Benj. Briscoe's Maxwell—Winner of Second Prize.

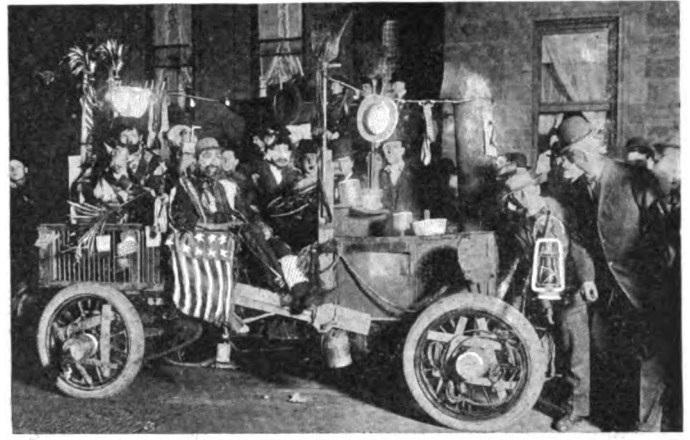

DeWitt Company's Hobo Car—Grotesque Winner.

new. There were chronological series of Haynes and Autocar machines, from 1898 to 1908; ancient Panhards, the original Welch, and 1898 Gasmobile, with "Birdie" Munger at the wheel; a '95 Apperson, a two-cylinder Locomobile, and an ancient White steamer among the racing cars of former and present times; Panhard, Renault, Mercedes, Lozier, Stearns, Simplex, Maja, Fiat and Allen-Kingston machines, Barney Oldfield and Joe Tracy being noticeable among the drivers.

The dealers' division followed. It was an almost endless procession, most of the makes being designated by special flags. Prominent in the line were 200 Maxwells, 70 Fords, 50 Oldsmobiles, and close to 40 White steamers. The Stearns cars had their names on red strips on a raised framework, and the Berliets bore big red flags, whereon were great white locomotives. The American Locomobile Automobile Company's garage, by the way, was the most elaborately decorated building en route, being festooned with electric lights from top to bottom. Rambler, Rainier, Haynes, Stevens-Duryea, and Pope-Hartford also make a brave numerical showing.

In the decorated division there were some notably elaborate creations. The first prize went to Gen. John T. Cutting's Oldsmobile. It was a dream in white, being completely smothered in pampas grass. Beneath a canopy a beautifully dressed girl sat; red electric lights illumined the canopy and a cluster of colored lights blazed in front. The driver and mechanic were dressed as white-hooded Arabs.

Benjamin Briscoe's Maxwell carried off the second prize. A queen surrounded by her ladies-in-waiting sat beneath a canopy of lilies and hydrangeas. The wheels were banked with chrysanthemums and the bonnet and driver's seat were enveloped in hydrangeas, colored electric lights illuminating the whole. Honorable mention was accorded the Oldsmobile company's other entry, a lilac-decked car, beneath whose canopy stood the Goddess of Liberty surrounded by pretty girls garbed in white.

The prize for the most grotesque car went to the DeWitt Auto Company's "hobo" car. A cooking stove with standing pipe formed the bonnet and tomato cans abounded. The wash was hung out to dry and brooms and brushes were elevated, while

behind a boy's box goat-wagon dragged. The driver and passengers of this were made up as tramps.

Another clever comic conception consisted of the presidential candidates in a Lozier, in which the driver was Roosevelt; the mechanic, Taft, and the passengers Hughes, Cannon, and Bryan, all being well made up to resemble the famous men named. The sign above the driver's seat was: "Me or Him;" on the tonneau it read: "Have We a Show?" "My Message to My People" being behind. It was blank. Peter J. Fisher's car was dressed with all the flags of the hockey teams, while L. A. Hopkins' American Mors limousine was most artistically decked with colored electric lights. Dr. Julian P. Thomas, the aeronaut, had a flying machine rigged up on a motor tricycle. It did not, however, get as far as the reviewing stand.

Two boys rigged up a curved-dash Oldsmobile runabout as a 'round-the-world car that left Paris, April 7, 1907, and reached New York, April 7, 1908. It was loaded with tire and camp utensils and covered with mud. In the commercial section there was a stunt that aroused much merriment. Hitched to the tail of a motor truck was an old equine quadruped with a sign: "The Passing of the Horse."

One of the most amusing incidents of the entire parade was the arrest of Elwood Haynes by Bicycle Policeman T. H. Kerrigan, who discovered that the original Haynes of 1893 was minus a license number, and he accordingly placed the veteran auto builder under arrest at Broadway and Fifty-seventh street. The magistrate, however, decided that he could release Mr. Haynes without violating the law.

The commercial vehicle division was an amazing demonstration of the varied utility of the automobile. It embraced sight-seeing 'buses, furniture vans and many types of delivery wagons. The B. F. Goodrich Company had an elaborate float showing a monster Goodrich tired wheel illuminated by electric lights. The Continental and Firestone people also had trucks. Other trade exhibits included the Studebaker, Frayer-Miller, Panhard, Splittorf, Fickling and Jones Speedometer. The Hewitt Motor Company showed many varieties of trucks and the New York Transportation Company put out a squadron of taxicabs.



Three Tire Companies Figured Prominently in Commercial Vehicle Divisions—Continental, Firestone, and Goodrich.



# CHICAGO'S CARNIVAL CONTENDED AGAINST WEATHER

CHICAGO, April 4.—The first experience of the Chicago Automobile Trade Association in the promotion of a Spring carnival has left a satisfied feeling among the dealers, the only regret being that the weather was a little too chilly for comfort. The carnival came to an end to-night, after a week's run, and the local trade now is prepared to fall back to the routine pace and await the results of their show efforts. Summing the situation up, one feels that the affair would have been a much greater success had it really seemed more like Spring. Four days it either rained or was so cold that few cared to venture out for demonstrations, but the latter end of the week the weather man relented, and the brand of weather improved.

It was more a promoter of sporting events than as a show impressario that the trade association shone, the illuminated parade, two gymkhanas, and a tug-of-war affording enough variety to interest the public and attract it to the "Row" in goodly numbers. But again the weather was against these events. The parade last Saturday night was witnessed by some 30,000 people, but it was a shivery lot, and the occupants of the cars braved pneumonia in making the circuit of the three sides of the city. Wednesday night had been selected as gymkhana night, but at noon that day it was raining, and Chairman Paulman decided to postpone until the following night. At 4 o'clock, however, the weather man was proved a false prophet. He had predicted snow, and that scared Paulman. However, at 4 o'clock, the sun came out, the clouds disappeared, and Paulman immediately decided to run the affair, after all, that night. He did, and it was a great success—so great, in fact, he decided to repeat Thursday night, with the tug-of-war as an additional feature.

The gymkhana was the first one Chicagoans ever had seen, and they liked it immensely. The technical committee of the Chicago Motor Club was requested to handle it, and it framed the rules, appointed the officials, and scored another success in the promotion line. The rules divided the gymkhana into five sections, the route being laid between Twelfth and Sixteenth streets.

### Ford and Elmore Were Winners.

These five sections made a gymkhana which certainly furnished enough novelty to amuse the bystanders, who thoroughly appreciated the efforts of the drivers. In four of them it was necessary to drive on the high gear, but in the teter it was allowable to switch gears and to use the brakes. Twenty-four cars took part in Wednesday night's gymkhana, and twenty-eight on Thursday night. In each a different winner was evolved—a Ford run-about, driven by M. J. Lanahan, capturing the honors of the first affair, and an Elmore touring car, driven by Harry Sultzpaugh, taking the renewal. That experience counts was shown Thursday night, when much better work was done by the contestants. The Ford was first Wednesday night, with seven points penalization against it, while the Elmore improved on this the next night by going through with only one demerit, that imposed in the lemon-spearer stunt. Eight of the cars Thursday night beat the Ford's score, showing that practice makes perfect. The Ford was one of those to eclipse the first night's performance, but it only landed in a tie for fourth with the Mitchell, which was a runner-up in the first affair.

### Average Race Was a Feature.

Probably the feature of Thursday night was the average race, in which the object was to maintain a 4-mile pace. In this, two cars hit it on the dot, the Elmore and the Welch. Wednesday night no one was perfect, the Pierce-Arrow and Mitchell being closest, with one point penalty. In the apple race, too, there was marked improvement, only three being perfect in the first attempt, and nineteen in the second.

The Elmore, despite its almost clean sheet, did not have much

to spare, for it was pushed closely by the Overland and Buick. Price, in the Overland, missed out through failure to maintain the 4-mile clip, being penalized two points, the only demerits he drew. The Buick, which was not in the first gymkhana, also slipped up in the average race, being penalized four points.

In the test Wednesday night the drivers clearly showed lack of experience, Lanahan being about the only one to have his lesson anywhere near perfect. His margin of victory was great, he being twenty-one points to the good of the Mitchell. He handled his car cleverly in the teter and obstacle events, and might have been tied with the Overland Thursday night had he not knocked over three blocks in the obstacle race in his anxiety to make a good score.

### Rapid Wins Tug-of-War.

The tug-of-war Thursday night resulted in a clean-cut win for the Rapid truck, which outpulled the Meiselbach with little apparent effort three successive times. It was best three in five, and it was necessary for the winner to pull the other truck 10 feet. Each car was loaded with about 800 pounds of pig lead to give traction, William Duffy driving the Rapid, and Harry Endicott the Meiselbach. Both trucks were equipped with two-cylinder double-opposed motors, the Rapid being 24-horsepower and the Meiselbach 28. The former had planetary gear and the latter is friction-drive. In none of the three trials did the Meiselbach make a fight, the Rapid getting the jump each time and hauling its rival the required 10 feet without any apparent effort. Herewith are the scores:

### Wednesday's Gymkhana.

Pos.	Car	Average Race	Apple Race	Saber-ing	Teter-Board	Obsta-cle Race	Penalty Points
1	Ford	4	1	2	0	0	7
2	Mitchell	1	1	25	0	1	28
3	Pierce-Arrow	1	0	0	28	2	31
4	Rambler	2	4	1	25	0	32
5	Stoddard-Dayton	7	25	2	0	1	35
5	Franklin	3	0	2	30	0	35
7	Woods	25	4	7	0	1	37
8	Diamond T.	4	25	1	0	10	40
9	Overland	2	25	2	15	0	44
10	Holsman	4	0	25	25	0	54
11	White	3	25	0	25	2	55
12	Autocar	5	25	1	30	2	63
13	Knox	8	25	25	6	0	64
14	National	4	25	26	30	0	65
15	Welch	2	25	25	0	14	66
16	C-F	6	25	4	30	2	67
17	Baker electric	2	25	25	18	0	70
18	Royal	7	25	1	30	10	73
19	Pierce-Racine	25	25	25	0	1	76
20	Thomas-Detroit	4	25	25	25	1	80
21	Lambert	2	25	25	30	1	83
22	Maxwell	25	25	25	0	12	87
23	Queen	25	25	25	0	12	87
24	Apperson	25	25	0	30	14	94

### Thursday's Gymkhana.

Pos.	Car	Average Race	Apple Race	Saber-ing	Teter-Board	Obsta-cle Race	Penalty Points
1	Elmore	0	1	1	0	0	1
2	Overland	2	0	0	0	0	2
3	Buick	4	0	0	0	0	4
4	Ford	1	1	1	0	3	5
4	Mitchell	3	1	1	0	0	5
4	Knox	1	0	2	0	2	5
5	Oldsmobile	4	0	2	0	0	6
5	Moline	2	0	4	0	0	6
6	Stoddard-Dayton	4	0	1	0	2	7
6	Rambler	4	0	1	2	0	7
7	Diamond T.	6	0	3	0	0	9
8	Pennsylvania	9	0	2	0	2	12
9	Pierce-Arrow	2	0	0	23	0	25
10	Franklin	25	0	2	0	0	27
11	C-F	4	0	0	15	11	30
12	Autocar	2	0	0	30	1	33
12	Stearns	2	0	2	25	4	33
13	White	1	0	0	30	4	35
14	Lambert	3	1	0	30	1	35
15	Welch	0	0	3	30	4	37
16	National	5	3	1	30	0	39
16	Woods electric	4	0	5	30	0	39
17	Queen	25	3	3	23	3	57
17	Corbin	25	0	2	30	0	57
18	Pierce-Racine	25	25	25	0	3	78
19	Thomas Forty	8	25	25	30	0	88
20	Cleveland	7	25	2	30	25	89
21	Simplex	25	25	25	30	0	105



### PARIS SORE OVER BAD BEATING.

PARIS, March 31.—There will be no glad hand, champagne, bouquets or official receptions for Brinker, Roberts, or whoever may succeed in piloting the Thomas Flyer to the French capital. Paris has received news of the American car's arrival at San Francisco and has not thrown its *bonnet rouge* into the air. It would be more correct to say that Paris has damned the New York-Paris tour, not in a polite, genteel, fashionable manner, but in that vehement style that is characteristic of the Gaul.

Godard has written home hair-raising accounts of the dangers and difficulties of a run to San Francisco. In wild language he tells his compatriots how the "peasants" have robbed and deceived him, how wicked they are and how they took advantage of his lack of knowledge of the country. The meager 24 horses under tricolor bonnet were insufficient in competition with the 60-horsepower of the American, and the trail of gold which the Yankee could scatter along the road appalled the Frenchman.

What Godard has to say does not influence the public very much, for there is a strong impression since some of the Pekin-Paris facts came to light that the French driver is not a very reliable individual. Georges Prade, editor of *Les Sports*, may be taken as a person holding a much more sober view of the situation, but he has to write that "the sole effect of New York-Paris has been to give the Americans an opportunity of proving that on American roads an American car is capable of meeting three French automobiles and scattering them all."

Says the Parisian editor: "The American car has triumphed because its ignorant, ill-equipped and unskilled rivals have had breakdown upon breakdown. The lesson of Pekin-Paris ought to have been sufficient for us; now it is New York-San Francisco, a defeat in the only country in the world in which French automobile commerce is increasing. At the bottom all the interest of the trip lies in this journey to San Francisco; afterwards it is a succession of boats and of journeys in British Columbia and Alaska, where there is nobody to see the competitors and where they can do no harm except to themselves. But a defeat in the United States—and defeat is but a feeble word—a defeat in which our best car is dead heat with the last, cannot but be deplorable to the name of France.

"I am certain that Motobloc and De Dion are not proud of the fact that they have been beaten by an American car that in this country we should place in the second class, by an Italian car which is not in the first rank, and to be dead heat at the rear with a German that has just entered the automobile industry. Happily the Grand Prix is coming, and the Thomas car is engaged in this great event. Then, I am certain, the American car will be brought down to its correct level. It is sad, however, to have to wait for the Grand Prix to save the French industry from the evil effects of the Round-the-World tour."

#### About the Alaskan Route.

The cars are to travel over the Government mail route to Fairbanks, down the Tanana to Fort Gibbon, and down the Yukon to Kaltag, across the trail to Unalakleet, and along Norton Sound to Nome. The distances are varied and some of the stretches will require extra fuel preparations:

To—	Miles	To—	Miles	To—	Miles	To—	Miles
Comfort Camp...	10	Creek .....	156	Clark's .....	334	To—	Miles
Workman's .....	18	McMullin's .....	172	Thirty-five-mile .....	341	Kofrine's .....	614
Roadhouse .....	26	Paxton's .....	188	Piledriver .....	346	Malols .....	640
Ptarmigan Drop .....	26	Yost's .....	206	Byler's .....	356	Kayukak .....	680
Beaver Dam .....	34	Casey's Cache .....	216	Johnson's .....	358	Nulato .....	700
Tiekhill .....	48	McDevitt's .....	223	Murray's .....	365	Kaltag .....	735
Ernestine .....	60	Parker's .....	237	White's Road-house .....	367	Old Woman .....	775
Tonsina Road-house .....	77	Donnelly's .....	249	Fairbanks .....	376	Unalakleet .....	835
Willow Creek .....	90	Sullivan's .....	293	Chena .....	388	Shakolik .....	880
Copper Centre .....	102	Little Delta .....	314	Tolovana .....	444	Bonanza .....	908
Taslina .....	114	King's .....	324	Baker .....	474	Isaac's Point .....	948
Gulkana .....	132	Munson's .....	333	Fort Gibbon .....	534	John Dexter's .....	1,008
				Mouse's Point .....	584	Bluff .....	1,036
						Solomon .....	1,062
						Nome .....	1,098

### THOMAS FIRST ON ALASKAN SOIL.

SAN FRANCISCO, April 7.—By the arrival of the De Dion here, where they received an enthusiastic reception, the Frenchmen will be enabled to start on an equal footing with the Italians in Alaska. The Germans are in hard luck, having broken down again at Kelton, Utah, compelling a second return to the Union Pacific shops at Ogden, Utah.

Monday was a day of rest for all the participants in the New York-Paris automobile race, as the arrival of the Thomas on the *Santa Clara* at Valdez, the overhauling of the Zust at San Francisco, and the repairing of the De Dion and the Protos at Tulare, Cal., and Kelton, Utah, respectively, could hardly be called work, when compared with what the crews have been undergoing on the road. By reaching Alaska at this time, the Americans in the Thomas gain a full fifteen days' lead over their nearest competitors, the Zust crew, but as the latter cannot leave San Francisco until April 10, and cannot sail from Seattle until April 16, the De Dion will have an opportunity to get on an even footing with them, so that the Italian and the French cars will arrive in Alaska together. Two weeks at this season of the year may make a tremendous difference in the conditions in Alaska, and it remains to be seen whether the lead thus gained will be an advantage to the Thomas or not.

For a time it looked as if the German crew would have an opportunity to catch up with their Italian and French contemporaries and take the same steamer for Alaska, but they had the misfortune to break the differential at Kelton, Utah, which caused a delay of two whole days. They still have Death Valley to cross in their heavy car, and then the run up through California, either through the interior, as the Thomas and De Dion went, or along the coast, following the track taken by the Italians. The distance is 1,200 miles, which will mean at least eight days of traveling, so that there is no hope of the Protos leaving Seattle with the Zust and De Dion. But for its mishap between Los Angeles and San Francisco, which cost a day, the Zust crew would have been able to sail from Seattle April 8.

The cordial receptions that they have received at every point along the route since leaving the snows of Wyoming, not alone from their own countrymen, but from the entire population of every town passed through, have done much to encourage the foreign crews. They have had tremendous odds to contend against—conditions far worse than they had ever dreamt of, but a few days in a milder climate and the comparatively easy going of the last stretches of the transcontinental trip have sufficed to make all of them very optimistic, and they will begin the second installment of the race with renewed vigor.

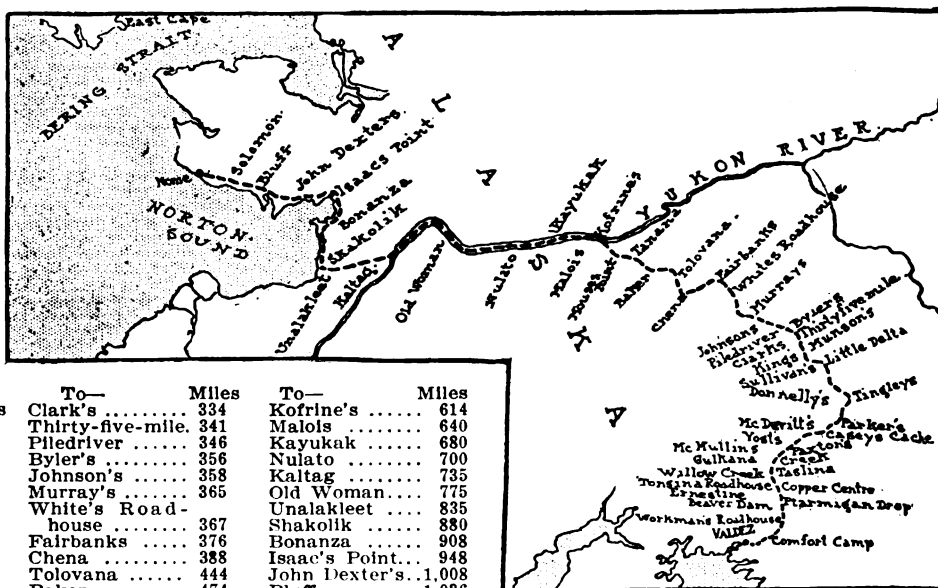

Map of the Route Through Alaska.



Oldfield Trying Course with H. W. Whipple's Stearns.

**BRIARCLIFF TROPHY RACE, APRIL 24, SURE.**

There will be no postponement of the Briarcliff trophy race after all, despite the fact that some parts of the course were so deep last week as to be impassable. At a meeting of the entrants, held on Thursday of last week, at which 17 of the 20 cars nominated were represented, to discuss the situation, it was decided to go ahead with the contest on the date originally scheduled, April 24. It was pointed out that a month's delay would be very expensive to the concerns that had engaged crack drivers and prepared for elaborate training outfits that the race was originally intended to be a strenuous road rather than a mere speed test of cars and that the contest had been scheduled for April to boost early Spring trade. Besides assurances were forthcoming from the management that a big force of workmen could be put on the road so as to have it ready, not only for the race but for preliminary practice as well.

Entries were announced as finally closed with 22 nominations in all, four additional cars having been added to the list at the eleventh hour, a Simplex, named by C. A. Singer; a Benz, entered by Louis J. Bergdoll, of Philadelphia; a 40-horsepower Bianchi, entered by Percy Owen, Inc., the American representative of the Italian car, which will be handled on the course by Felix Prossen, and a 35-horsepower Renault, similar to the first car of the same make that has been listed, and which has been entered by Robert Guggenheim. It is not known as yet who the driver of the second Renault will be. The entries in full are:

Car.	Entrant.	Driver.
Hol-Tan .....	C. H. Tangeman.....	Hilllard
Renault .....	Paul La Croix.....	Bernin.
Stearns .....	A. W. Church.....	Vaughan.
Stearns .....	H. W. Whipple.....	Oldfield.
Flat .....	E. R. Hollander.....	Cedriño.
Isotta .....	J. H. Tyson.....	Strang.
Isotta .....	C. M. Hamilton.....	Poole.
Isotta .....	C. M. Hamilton.....	Harding.
Stearns .....	F. B. Stearns.....	Leland
Allen-Kingston .....	A. Hammersteln.....	Campbell.
Panhard .....	A. Massenat.....	Robertson.
Lozler .....	H. A. Lozler.....	Mulford.
Maja .....	J. J. Brown.....	Murphy.
Flat .....	Joseph Josephs.....	Parker.
Thomas .....	H. S. Houpt.....	Roberts.
Apperson .....	S. B. Bowman.....	Lytle.
Simplex .....	C. A. Singer.....	Watson.
Benz .....	L. J. Bergdoll.....	Bergdoll.
Simplex .....	C. A. Singer.....	Seymour.
Bianchi .....	Percy Owen, Inc.....	Prossen.
Renault .....	Robert Guggenheim.....	

It was finally decided at this meeting to make the distance 10 laps of the course, or approximately 300 miles, and as it is not to be expected that the roads will be in the very best of condition, the running of the race will probably consume six hours. The event will be one wherein the skill of the driver will be a big factor, and victory may not go to the fastest car. The brash one may have his chances spoiled by eagerness and speed.

**HOW TO REACH BRIARCLIFF COURSE.**

By H. A. GRANT.

Probably every automobilist within range of the stock chassis race course at Briarcliff plans to be there on and before April 24. The writer lives but a few miles from the course, and has motored all over this section. Possibly, the following information may be of use to your readers:

I would say that in an article recently published, stating that the Harlem Railroad reached Briarcliff is an error. Briarcliff is reached by the Putnam Division.

To reach Briarcliff by automobile: From New York City follow up Riverside Drive to Kingsbridge, thence to Yonkers, Hastings, Ardsley, and Tarrytown. At Tarrytown, at the corner of Broadway and Main street, turn sharply to the right and follow the trolley tracks for about 200 yards; here the trolley line branches off through a cut. Continue along the road until you reach the summit of the hill and follow straight and *do not* turn to the left.

After descending a slight grade, you will cross the Putnam Railroad tracks; after crossing, follow along the shore of the lakes to East View, a small town situated on the course. At East View, I am informed, a grandstand is being erected. For particulars, inquire of Koenig Bros., Tarrytown, N. Y.

The race starts at Briarcliff. At East View, any one can direct you to Briarcliff, which is about six miles away.

To reach it by railroad: Those who go by train should take the Putnam Railroad at One Hundred and Fifty-fifth street. Get off at East View, where a stand is being erected, or at Briarcliff.

Another way to reach the course is to take the New York Central, Hudson Division, to Scarborough, and drive about two miles to the Briarcliff Inns. Unquestionably, these will be filled to overflowing, and, therefore, rooms should be engaged now.

The Harlem Railroad reaches Valhalla, a small station about a mile beyond White Plains. This brings you at a point in the course from which an excellent view can be had of the race.

There are other points, reached both by trolley and railroad, but the three mentioned above give the best hotel accommodations. Those who decide to witness the race from East View will find accommodations at the Florence House, Tarrytown, from which arrangements have been made to take people to the course.

**[CONNECTICUT WANTS VANDERBILT CUP RACE.**

BRIDGEPORT, CONN., April 7.—At the annual meeting of the Bridgeport Automobile Club, held last night, F. T. Staples was elected president. The club is greatly interested in the effort to secure the Vanderbilt Cup Race for Connecticut. Highway Commissioner James B. McDonald was present at the meeting and stated that in his opinion Connecticut had the roads for such a contest. A. L. Riker was selected as chairman of a special committee to look into the matter of a course.



Maja Entrant on a Picturesque Briarcliff Stretch.

## FIFTH ANNUAL A.A.A. RELIABILITY TOURING CONTEST

**F**RANK B. HOWER, chairman of the A. A. A. Touring Board, has promulgated the rules for the great national trade and pleasure run of 1908. Giving its new and official title, however—a matter of no little significance, by the way—it will be known as the "Fifth Annual Reliability Touring Contest of the American Automobile Association." It also includes the contest for the Charles J. Glidden trophy for touring cars, and the Hower trophy for runabouts.

It will start at Buffalo, July 9, and end at Saratoga, on or about July 24.

Entries will close with Chairman Hower at noon, July 3, at the Touring Board office, 760 Main street, Buffalo. The entry fee for each car is \$200 and must accompany its nomination. Numbers for the tour will be issued in the order of the receipt of the entries.

The rules for this year's contest, which were framed after consultation with and approved by manufacturers of various affiliations, embracing makers of different cars, present not a few noteworthy changes from those of last year, and to some considerable extent show signs of the rule-makers having given some heed to last year's criticisms and complaints.

The most radical innovation is that calling for a classification of the contesting cars by price, accompanied by a corresponding variation of the daily miles per hour scheduled for the different classes of entrants, for both the Glidden touring car and the Hower runabout trophies. Touring cars have been divided as follows:

- Class A.—Cars valued at \$3,500 and upwards.
- Class B.—Cars valued at \$2,500 and up to \$3,500.
- Class C.—Cars valued at \$1,500 and up to \$2,500.
- Class D.—Cars valued under \$1,500.

In the matter of time schedule requirements when the running time shall exceed 7 1-2 hours, the running time will be:

- Class B.—Will exceed that of Class A 15 minutes.
- Class C.—Will exceed that of Class A 30 minutes.
- Class D.—Will exceed that of Class A 45 minutes.

When the daily running time shall be less than 7 1-2 hours, the running time will be:

- Class B.—Will exceed that of Class A 10 minutes.
- Class C.—Will exceed that of Class A 20 minutes.
- Class D.—Will exceed that of Class A 30 minutes.

Runabouts have been divided as follows:

- Class A.—Cars valued at \$1,500 and upwards.
- Class B.—Cars valued under \$1,500.

When the daily running time shall exceed 7 1-2 hours, the running time of Class B will exceed Class A 15 minutes.

When the daily running time shall be less than 7 1-2 hours, the time of Class B will exceed that of Class A 10 minutes.

The running time will be posted the night before and each contestant must calculate his own schedule.

Another radical change lies in absolving cars detained by tire troubles from penalization for tardiness. Motors, however, must be kept running all the time the tire repairs are being made. If the motor stops or other work on the car be done, then there will be no raising of the penalizations.

This year official observers will have to be carried, who must make their reports each night. They will, to speak comprehensively, have to be identified with the entrants, if makers, as officials, employes or dealers. Non-trade entrants will also name observers for their cars, subject to the approval of the chairman. Observers will, of course, ride in makes of cars other than those entered by their nominees. They must remain with their cars at all times.

There will be no prohibition of a club making up its team of cars of a single make, as there was last year. A club

team must have at least three cars, but a club may enter several teams, if it so desires. This may add, it is easy to see, a factor of trade rivalry within a club.

Each entrant must be a member of the American Automobile Association. If a contender for the Glidden trophy, he must belong to a club affiliated with the A. A. A.; but if a Hower trophy candidate he need only be an individual member of the national organization.

Spare parts used in making repairs and replacements must have been carried on the car and included in the catalogue list submitted to the chairman. No repairs or replacements can be made at the night controls.

The acceptance of outside assistance in an emergency is covered by the following rule:

Where road conditions are so bad that a car cannot get sufficient traction to move, or is ditched, after reasonable effort has been made to extricate it, towing or other external means may be used to relieve the immediate distress only, but under no circumstances shall a car enter a night or any other control except under its own power. Where towing, or assistance from any external source has been received by the car, its observer must make a full and complete report, giving time, place, conditions, length of tow, and any other important details.

Candidate cars for the Glidden and Hower trophies will have to be given into the hands of the chairman at Buffalo 24 hours before the start of the contest for official examination and the checking of its list of spare parts carried.

The route will be marked as formerly by confetti: "Each day's tour will be preceded by a pacemaker's car, and any entrant or representative thereof who passes the pacemaker will be disqualified. If the pacemaker's car breaks down, or is compelled to travel at a rate of speed so slow as to impede the progress of the tour, his flag shall be transferred to the first car overtaking him, which car shall thereafter become pacemaker's car subject to the same conditions."

Provision is again made in this year's rules for a running off of any ties that may arise at the end of the Hower trophy competition.

The scheme of penalization is along the lines of that of last year. Each team is given an initial credit of 1,000 points. There is a penalization of a point for each minute or fraction thereof of tardiness at controls in excess of 2 minutes, and a point for each dollar or fraction thereof of value of parts used in replacements as per manufacturers' catalogues. These points of penalization are divided in each case by the number of cars constituting a club team.

Checking stations will be established along the route, but only so far as to prevent racing. Each driver will receive a card when checking out in the morning, which will name checking stations, so he can estimate his running time during the entire day.

Thos. Cook & Son will again have charge of hotel arrangements. Each entrant will have to take care of and handle such baggage as he and his guests may need.

### "GOOD ROADS" HOOPER "PENNSY" PRESIDENT.

LANCASTER, PA., April 4.—At the annual meeting of the Pennsylvania Motor Federation, held at the Hamilton Club, this city, Saturday last, Robert P. Hooper, chairman of the A. A. A. good roads committee, and treasurer of the Automobile Club of Germantown, was elected president for the ensuing year. The other officers chosen are: Dr. S. T. Davis of Lancaster and Peter A. Meixell of Wilkes-Barre, vice-president, and Paul C. Wolff of Pittsburg, secretary and treasurer. Norristown and Williamsport clubs were elected to membership. Twenty clubs now belong to the federation. Over 2,000 members are now enrolled.

# THE POWER AND SPEED OF RACING CARS

By HERBERT L. TOWLE, MEMBER SOCIETY OF AUTOMOBILE ENGINEERS.

A SHORT time ago a case was tried in New York City, which concerned a racing car of high power, for which the defendant in the suit had refused final payment on the ground that the car had failed to perform as expected. It fell to the lot of the present writer to analyze the more prominent features of design in the car in dispute, and determine whether or not they could be made satisfactory without radical reconstruction.

The car had made no sort of a speed showing under test, and one reason for this, which would have been enough even had the car been otherwise perfect, was found in the gear ratio. The motor was asserted by its designer to be capable of developing considerably over 250-horsepower. It might, in reality, have gone as high as 120- or even 150-horsepower, if the crankcase had not cracked, and if the camshafts had not been so light and springy as to demoralize the valve timing. But the rear wheels, which were 34 inches in diameter, were geared to make two turns to the engine's one. In other words, the engine had to overcome a leverage (even neglecting gear losses) double that against which it would work with 1-to-1 gearing; and at the

step further, and show how the right gear might have been determined without great labor or experiment, and using only data available to the designer when the car was built, a year and a half ago. Since that time, record performances have been made which make the selection of a proper gear somewhat easier; but, so far as the writer knows, no quick method of calculation has been pointed out which is of general application. Therefore, the method used by the writer in the above connection seems to be of interest. It is based on the determination of tractive effort—i.e., road plus wind resistance, or the equivalent of the drawbar pull of a locomotive.

Power is the product of force and velocity. The tractive effort in pounds, multiplied by the car's velocity in feet per minute and divided by 33,000, is the horsepower developed at the rear wheels. This power, plus that lost in transmission, is the brake power of the motor at that speed. This neglects slip, but for beach work that is not material.

According to data, for which the writer is indebted to Thomas J. Fay, the net mean effective pressure of a motor of

POWER, SPEED AND TRACTIVE EFFORT OF CARS AT ORMOND, JANUARY, 1905.

Name of Car.	Cylinders	Bore	Seconds Per Mile	Miles Per Hour	H.P. a if Piston Spd. = 1,100 ft. M.E.P. = 67 lbs.	H.P. b if Piston Spd. = 1,000 ft.	H.P. a x K.	H.P. b x K.	Tractive Effort (a)	Tractive Effort (b)
$T = \frac{375 \times \text{H.P.} \times K}{\text{miles per hour}}$										
Bowden's Mercedes	8	5.75"	32 4/5	109	117	106	88	79.5	302	273
W. K. V., Jr., '90" Mercedes ('04)	4	6.67"	39	92.5	78	71	58.5	53	237	215
Wallace, '90" Flat	4	6.5"	39 1/5	92	74	67	55.5	50	226	204
Stevens, '90" Mercedes	4	6.67"	40 2/5	91.5	78	71	58.5	53	240	217
Hawley's '90" Mercedes	4	6.67"	40 2/5	89.2	78	71	58.5	53	244	223
W. K. V., Jr., '90" Mercedes	4	6.67"	42 1/5	85.5	78	71	58.5	53	257	233
Sartori, '90" Flat	4	6.5"	45 1/5	80	74	67	55.5	50	260	235
Brokaw's Renault	4	5.9"	45 2/5	79.5	62	56	46.5	42	217	193
Vaughn, '40" Decauville	4	5.12"	48 1/5	75	46	42	34.5	31.5	175	157
200-h.p. Darracq ('06)	8	6.67"	29 2/5	122.44	156	142	117	106.5	357	325
Croker's Simplex	4	6.5"	.....	86	Actual H.P. 66		49.5			216

For piston spd. 1,000 ft. per min.:  $\text{H.P.} = \frac{D^3 C}{2.5}$ . C = No. of cyls. K is transmission efficiency. T is tractive effort. 1 H.P. @ 1 mile per hr. =  $\frac{33,000}{88} = 375$ .

highest velocity which the car could be expected—even by its designer—to attain, the engine speed would be far too low to permit developing the maximum power.

Let us illustrate by supposing a case: At 80 miles per hour, on level macadam, a car having side chain drive shows a rear wheel slip of about 3 or 4 per cent. On the beach (for which the above car was designed) the slip and rolling resistance are both less, the same gear giving a car speed of about 86 miles an hour. Allowing, in round numbers, 2 per cent. for beach slip, a 34-inch wheel makes 600 turns in one mile. At a mile a minute, this would be 600 r.p.m., and at two miles per minute 1,200 r.p.m. With the 1-to-2 gearing described, the engine would make 300 and 600 r.p.m. in the two cases. But an engine having a stroke between 6 and 7 inches should run between 1,000 and 1,100 r.p.m., having due regard for risk of breakage due to piston inertia; so that the power actually developed would not suffice to drive the car at the highest speed. The designer of the car stated in his testimony that he expected to achieve a speed of 150 miles per hour; but at that speed the engine would run only 750 r.p.m., and would develop, at best, three-fourths of its maximum power. As a matter of fact, it would evidently fail to drive the car anywhere nearly as fast as it might with proper gearing, or the balance between driving torque and road plus wind resistance being struck at some extremely moderate speed.

It was not difficult to show that the gear ratio chosen by the designer was farcically incorrect; but it was desirable to go a

racing dimensions—that is, the indicated M. E. P. multiplied by the mechanical efficiency of the engine—cannot be relied on to exceed about 67 pounds to the square inch. In moderate-sized motors—say, below 5 inches bore—higher compression is feasible, bringing the net M.E.P. up to 70 or 75 pounds. A handy formula is:

$$\text{H P} = \frac{D^3 \text{ L R C P}}{1,008,500} \text{ in which}$$

- D is piston diameter in inches.
- L is stroke in inches.
- R is revs. per minute.
- C is number of cylinders.
- P is net M. E. P.

Assuming a piston speed of 1,000 feet per minute, and 67 as the value of P, this formula leads directly to the A. L. A. M. formula

$$\frac{D^3 C}{2.5}$$

For a piston speed of 1,100 feet per minute, we have

$$\text{H P} = \frac{D^3 C}{2.27}$$

The power developed by any racing motor, or certainly any motor built between two and four years ago, is likely to fall within or very close to the values given by these formulas. It is true that the powers thus calculated often fall considerably



short of the reputed power of particular motors, but that need not worry us, particularly in connection with the present subject. It was quite a common fault with the motors of a few years ago to disappoint their designers in this respect.

**An Analysis of the Florida Speed Efforts.**

Nearly all the best speed records at Ormond Beach were made in January, 1905. A few were made in 1904, and in 1906 the eight-cylinder Darracq put the highest mark for a gasoline car at 122.44 miles per hour, where it has since remained. All but the last of these records were made before work on the racing car above mentioned was begun. The cylinder dimensions of most of these cars had been published, and it was, therefore, easy to calculate their approximate horsepower by the above formulas, assuming 1,000 and 1,100 feet per minute piston speed. From these the power developed at the rear wheels followed by deducting a suitable percentage for transmission losses. So far as the writer is aware, no reliable published data were available two years ago on transmission losses, but 25 per cent. appears a fair average. So long as similar cars are considered, its precise value is not important, since its only effect is to scale all the computations up or down alike and on that account it is not at all necessary to take it into consideration in the present connection.

From the best speed of the car, and the computed horsepower at the rear wheels, the tractive effort was obtained by the formula:

$$T = \frac{375 \times H P \times K}{\text{Miles per hour}}$$

in which

- T is tractive effort in pounds.
- H P is engine brake horsepower.
- K is transmission efficiency, or 75 per cent.

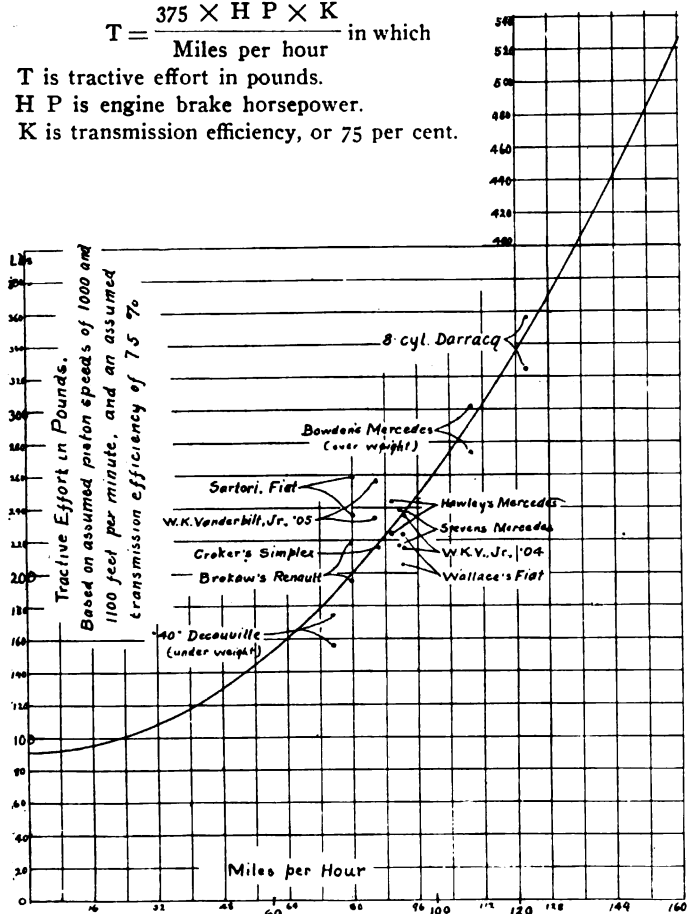

Fig. 1.—Relation between tractive effort and speed of standard racing car.

This formula is derived as follows:  
One mile per hour is 88 feet per minute.

Tractive effort for 1 H P at one mile per hour is  $\frac{33,000}{88}$  or 375 pounds.

Obviously, the tractive effort as thus derived is actual only if the motor actually developed the full power called for by the

formula. If the motor was not perfectly tuned up, or if it was overgeared, the car would run slower than it should, and the apparent tractive effort, being in inverse ratio to the speed, would be correspondingly greater than the actual. Similarly, a motor exceptionally well tuned, or speeded to run faster than usual, would result in a higher car velocity; but this higher velocity, though in reality accompanied by increased tractive effort, would not appear thus on calculation, since the formulas take no account of unusual M. E. P. or engine speed. On the contrary, the apparent tractive effort would be less instead of greater. For this reason, the method is only safe as a means of obtaining averages from a considerable number of cars. When thus used, however, the apparent tractive efforts may be plotted, and a curve drawn, which will fairly represent the speed and tractive effort for any new case.

The above process was followed for the cars enumerated in the table. It will be seen that for the Mercedes and Fiat cars, which preponderate, the apparent tractive efforts lie very close together in the diagram. In all cases the tractive efforts have been calculated for both 1,000 and 1,100 feet piston speed. Of the cars which lie conspicuously outside the curve, two—the Fiat, driven by Sartori, and W. K. Vanderbilt, Jr.'s Mercedes, in 1905—were evidently not working at their best. The third, the Decauville, was about 700 pounds under the racing weight to which the others closely conformed, and its very low tractive effort is thereby explained.

A curve of tractive efforts was first sketched in by hand, and then was found by trial to conform very closely to the formula:

$$T = .035 W + .0017 A V^2$$

in which

- W is a total weight of car and driver, taken as 2,600 pounds.
- A is front area of car and driver, taken as 10 square feet.
- V is velocity of car in miles per hour.

The first expression of the formula represents the road resistance, the second the wind resistance. The coefficients, of course, are subject to change, but for average conditions, as represented by cars of Mercedes form, the curve seems to fit quite closely. As finally drawn in, it represents the formula accurately. It will be noted that the Simplex, driven by the unfortunate Frank Croker, appears in the diagram very close to the curve. I am told by Mr. Fay, the designer of that car, that it actually developed the horsepower and speed credited it in the table, so that it gives a good check on the correctness of the curve at that point.

**A Curve of Tractive Efforts for Universal Use.**

We thus have a curve to which we can determine approximately the performance and required gear ratio of any racing car of standard type. Suppose we have an eight-cylinder motor of six inches bore and stroke, designed to stand a speed of 1,200 r.p.m. and develop its full torque at that speed. This is 1,200 feet piston speed, or one-fifth greater than the A. L. A. M. formula assumes. The power, therefore, will be:

$$H P = \frac{D^3 C}{2.5} \times 1.2 = 138.$$

At the rear wheels it will be  $138 \times .75 = 103$ .  
By our formula:

$$T = \frac{375 \times 103}{\text{Miles per hour}} = \frac{38,600}{M P H}$$

This enables us to determine the speed at once by applying trial calculations to the curve. Thus for 110 miles per hour, the tractive effort required by the curve is 296 pounds; that obtained by calculation, 350. For 120 miles per hour, we have 335 pounds required, and 321 available. For 118 miles per hour, we have 328 required, and 327 available. Therefore, 118 miles per hour will be our speed, representing 1180 revs. per minute of the wheels. This is so near the engine speed that it may not be worth considering, but if the driving bevel could be made one tooth smaller than the driven, to permit the engine to turn a very little faster than the wheels, some advantage might be

gained; or the difference could be adjusted between the gears and sprockets.

Up to this point we accomplish little by the method proposed that might not be more directly reached by a simple horsepower speed curve, such as may readily be constructed from the curve of tractive effort (See Fig. 2). Working on the tractive effort curve, however, has two advantages. It separates clearly the driving force required to overcome wind resistance from that absorbed by the beach itself. The latter works out by the formula to about 90 pounds for cars weighing 2,600 pounds complete; and, so far as the writer is able to learn, this is not far wrong. By separating these two elements in the total resistance, we are able readily to adapt our calculations to cars of other than the Mercedes-Fiat weight and front area.

The second advantage of using the tractive effort curve is that it enables us to ascertain at once,

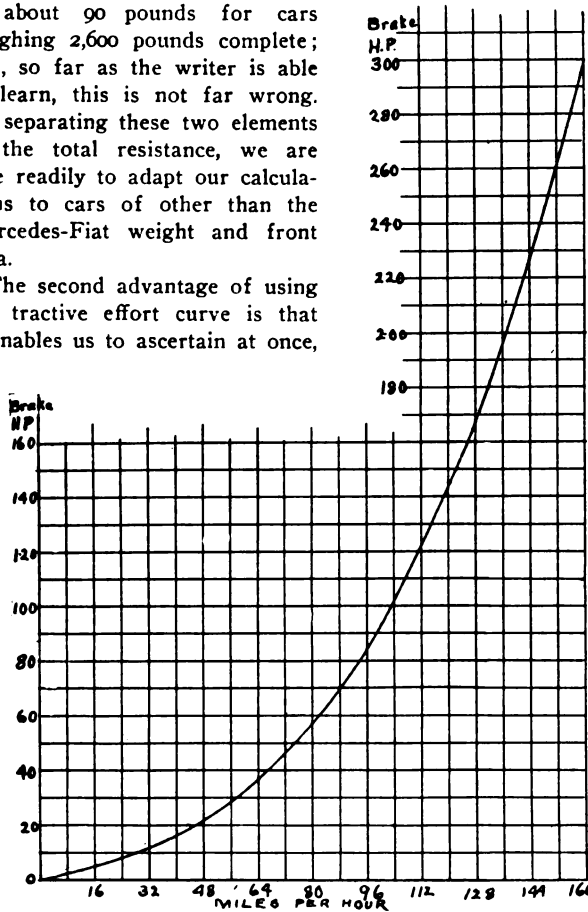

Fig. 2.—Relation between motor horsepower and speed of standard racing car.

within close limits, the speeds obtainable with incorrect gear ratios. In doing this, it is only necessary to know how the M. E. P. developed by the engine at the car's actual speed compares with that expected under correct conditions. If there be no material difference, we simply calculate the mean torque developed by the engine, multiply it by the product of the mechanical efficiency and the gear ratio, and divide by the rear wheel radius, thus obtaining the tractive effort. From this, the attainable speed with that gear ratio follows at once by the curve.

To illustrate this point, let us assume the eight-cylinder 138-horsepower motor, above supposed, has been geared to make 8-10 of a revolution to one turn of the rear wheels. One horsepower at 1,200 r.p.m. giving a torque of:

$$\frac{33,000 \times 12}{1,200 \times 2 \times 3.1416} = 52.5 \text{ inch-lbs.}$$

Therefore, a motor developing 138 horsepower at that speed will exert a torque of  $52.5 \times 138 = 7,250$  inch-lbs. Multiplying this by 75 per cent. and dividing by the wheel radius (17 inches) and gear ratio, we have

$$\frac{7,250 \times .75 \times .8}{17} = 256 \text{ lbs. tractive effort.}$$

On the curve, Fig. 1, this corresponds to a speed of about 98 miles an hour, as against 118 for the correct gear. At that speed the motor would be running  $980 \times .8 = 786$  r.p.m.

If the motor be undergeared so that it makes 1.2 revolutions to one turn of the rear wheels, we shall have

$$\frac{7,250 \times .75 \times 1.2}{17} = 383 \text{ lbs. tractive effort.}$$

This indicates a velocity of about 133 miles per hour, provided the motor maintains its torque at the excessive speed—1,600 r.p.m.—which it will have to develop, and provided it does not break down somewhere from the violence of the piston inertia forces, which augment as the square of the speed, and are, therefore, 78 per cent. greater at 1600 r.p.m. than at 1,200 r.p.m.

To illustrate further, let us suppose that the engine which figured in the lawsuit above mentioned had been able to give 120 horsepower at 1,000 r.p.m. This represents a torque of 7,570 inch-pounds. Assuming a transmission efficiency as high as 75 per cent., despite the adverse gear ratio, we have:

$$T = \frac{7,570 \times .75}{17 \times 2} = 167 \text{ lbs. for 34 inch}$$

wheels. This tractive effort will give a speed of only 67 miles an hour, at which the engine speed would be but 335 r.p.m. At that speed the torque would probably be considerably below the normal, which would cause the actual speed to be still less. If the actual torque were 20 per cent. below the maximum, the tractive effort would be  $1,674.8 = 124$  lbs., representing a car speed of 50 miles per hour. What the torque really was can only be guessed, as the motor was never tested; but the retarding effect of an excessively high gear is plain.

It will be noted that calculations, which do not assume some definite speed for the motor, but aim only to ascertain what car velocity can be attained with a certain gear ratio, cannot be made from the horsepower-speed curve, since the horsepower which will be developed is not known. On the other hand, if we arbitrarily fix the engine speed, we thereby fix its power, and can, therefore, determine the proper gear ratio from the car speed given by the power-speed curve.

To show their character, the curves of tractive effort and horsepower have been extended to their values for a speed of 160 miles per hour. At the present time, any such speed is merely speculative, and calculations regarding it must await the confirmation of practice. However, it is of interest to note that 527 pounds, the calculated tractive effort for 160 miles per hour, is close to the slipping point for rubber tires on macadam, assuming average weights on the rear wheels of racing cars. Apparently, therefore, that speed is near the theoretical limit unless rear wheel weight be increased. From the horsepower required, it is evidently quite close to the practical limit likewise.

### CONCERNING SHAFT VERSUS CHAIN.

Inch by inch, or, perhaps, it would be better to say link by link, chains are giving way in the battle for transmission supremacy abroad, says *Motor Talk*. Chains may well cry to be saved from their friends, for verily some of their champions treat them most shamefully. Too much confidence in the chain's durability and efficiency leads apparently to the most disgraceful neglect. If driving chains had no more important duty to perform than to keep a dog in his kennel, there would no fault be found with their neglect; but where is the sense, I should like to inquire, in paying the most elaborate attention to one end of the car—the motor end—timing the valves to half a hair-breadth, finishing off the valve seats with crocus powder, etc., and then leaving the chains to grind themselves to pieces in all the grit and mud they can collect? Power microscopically conserved in one place only to be wasted in the most uncalled-for manner at another! There cannot be so very much power lost, say the wise ones, otherwise chains would wear out quicker. Such wisecracks cannot appreciate the difference in efficiency between a new chain and one that is stretched out of pitch. In fact they hardly know what pitch means, except in the vaguest kind of a way, until some day the chain mounts the teeth and crumples up a stay rod.

# COMPARING AMERICAN AND FOREIGN LIGHT CARS

By G. H. GODLEY.

TO the American observer, one of the most striking features of the English and French trade is the great demand for small four-cylinder cars of from 12 to 20-horsepower. These cars form a distinct class, and by no means an unimportant one, which is almost entirely unknown here. They are, in the main, designed along the lines of standard touring cars of higher power, but often a surprising amount of ingenuity is shown in the simplification of details.

These motor cylinders are cast either separately, in pairs, or *en bloc*, with a pronounced tendency toward the last method. The Darracq has the four cylinders, and their inlet and exhaust piping all in one casting. Magnetos form a part of the regular equipment on many cars, and provision is made for them on practically all the others. Air-cooling is unknown, but in some cases the water-cooling system has been simplified by the omission of the pump, the water circulating naturally, and often the radiator fan has been dispensed with also. Clutches are of different patterns, cone types being rather in the majority, with the multiple disc a close second, but there are also a number of special designs. Change gears are sliding with three forward speeds, often selective. Drive is almost invariably by shaft and live axle. Some makers, on account of the excessive cost of the drop-forged I-section front axle, have adopted a built-up design formed of two channel sections riveted together, back to back. Frames are usually pressed steel, carried on semi-elliptic springs in front, and either semi-elliptic, three-quarter, or platform springs in rear. The dimensions of a number of representative cars are given in the following table:

Name	H.P.	H.P. by Formula	Bore and Stroke mm.	Wheel-base In.	Tires In.	Chassis in London £
Argyll.....	14-16	20.1	.90 x 120mm	100 1/2	810 x 90	325
Darracq.....	14-16	17.9	.85 x 100	100	760 x 90	335
De Dion.....	12-14	14.0	.75 x 100	108	810 x 90	330
Gladiator.....	12-14	15.9	.80 x 110	100	810 x 90	325
Gregoire.....	10-14	15.9	.80 x 110	96	810 x 90	304
Gregoire.....	16-20	20.1	.90 x 120	103	{ 875 x 105, front 880 x 120, rear }	400
Horbick.....	12-16	15.9	.80 x 90	96	810 x 90	300
Humber.....	10-12	17.5	.84 x 95	102	760 x 90	{ 250 with body }
Mors.....	10-14	15.9	.80 x 90	102	820 x 90	350
Panhard.....	10-15	15.9	.80 x 120	112	{ 870 x 90, front 880 x 120, rear }	400
Renault.....	10-14	14.0	.75 x 120	107	{ 800 x 85, front 810 x 90, rear }	410
Scout.....	15	20.1	.90 x 115	112	810 x 90	355
Unic.....	16-20	18.7	.87 x 110	118	810 x 90	415
Vulcan.....	14	19.6	.84 x 110	102	810 x 90	315
West-Aster.....	14-16	17.5	.84 x 110mm	102	810 x 90	345

The only American cars which would come in this class are the 16-horsepower Franklin and the 16-22-horsepower Thomas town car—both too well known to need description.

## American Makers Have Developed Horizontal Type.

Instead of this type, American manufacturers have developed cars with two-cylinder horizontal opposed engines, placed either under the seat, with center chain drive, or in front, with shaft drive. It is true that these cars are usually considerably cheaper than the foreign cars listed above, the prices of the American type varying from \$1,250 to \$1,500, while the foreign type, after a body had been fitted, would average over \$2,000. There is one significant exception, however—the Humber. This car has a very wide reputation in England, and is undoubtedly of the very best construction throughout, yet by standardization and manufacturing in quantities its makers have been able to sell it, complete, with touring body, at £250, equivalent \$1,215. I take this to be sufficient proof that American manufacturers of small cars could do the same if they desired to replace their two-cylinder models by four-cylinder ones.

The question then stands: Which of these two types would be preferred by the average man about to spend \$1,250 on a car? There are several considerations on both sides. In the first place, the two-cylinder has comparatively large cylinders, with much less wall surface than a four-cylinder of the same

piston displacement. They also run at a lower speed. Consequently, other things being equal, the two-cylinder is the more economical, both in fuel and oil. If batteries are used for ignition, it is also more economical in current. Of course, no estimate can be made of the actual saving, but it would certainly be very noticeable on a monthly bill.

On the other hand, the four-cylinder car has the advantage in both silence and smooth running. Two-cylinder cars have made wonderful improvement in this respect, but from their very nature they can never hope to equal the four-cylinder. Another advantage of the latter is the use of shaft drive instead of center chain. A number of two-cylinder cars are now built with motor in front and shaft drive, but with a good-sized engine the narrowness of the available space makes necessary a very short stroke, with consequent loss of the efficiency and economy of this type. Further, the removal of the engine from under the seat allows the body to be hung much lower; this, together with the increased wheel-base, makes a great improvement in appearance and comfort. The old fallacy, that a short wheel-base, and high, full elliptic springs are peculiarly adapted to American conditions, has long been exploded.

## Necessity for Simplicity Is Self-evident.

As cars of this size are almost invariably driven by their owners, they must be as simple and easily cared for as possible. This condition seems at first to favor the two-cylinder. However, the horizontal opposed engine is, by its nature, spread out over three or four feet of space, with many long pipes and wires, which even the best designing cannot keep straight and clear. The new four-cylinder engines, on the other hand, and especially those *en bloc*, are so neat and compact that they seem much simpler than the others, while pipes and wires are remarkable chiefly through their scarcity. When the hood is lifted, the four spark-plugs stand up in a row, ready to the hand, instead of one being under the footboard and the other under the tonneau.

The choice lies, then, between economy of fuel and oil on the one side, and comfort, appearance and accessibility on the other.

Economy is doubtless an important consideration, but here it is outweighed. The day has passed when an automobile of any sort whatever was sufficient to glorify its possessor. The business man who has \$1,250 to invest in an automobile wants one which will compare in style and comfort, if not in speed, with the more expensive ones, and he will not haggle over 10 per cent. on his gasoline and oil bill.

The two-cylinder horizontal opposed engine is now finding its proper field in the auto-buggy, and I think it is a pretty safe prophecy that it will soon die out in the touring car. And, meanwhile, there is a great opportunity for the manufacturer who does in America what Argyll, Horbick, Humber and others have done in England.

## STEADY INCREASE IN AUTO EXPORTS.

Government statistics for the month of February, 1908, compiled by the Department of Commerce and Labor, show that 213 complete automobiles of a value of \$368,309, were sent out of the country, as compared with 151 cars of a value of \$301,240 for the same month a year previous. During the same periods, the value of the automobile parts exported reached \$75,394 in 1908, and \$47,124 in 1907. For the period of eight months ending with February in the years 1906, 1907 and 1908, the total values were \$1,771,313; \$2,873,246 and \$3,061,823 respectively. The most striking feature of the February, 1908, report is an increase of more than 100 per cent. in the value of the cars exported to Italy, although France also shows an increase of about 12 per cent., and other European countries are taking American cars.

## LETTERS INTERESTING AND INSTRUCTIVE

### QUERIES ON A NUMBER OF TOPICS.

Editor THE AUTOMOBILE:

[1,290.]—I write to you for information in regard to an article on "The Rubber-Knobbed Tire," by A. E. Morrison. Would write to him direct, but do not know his address. Who are the manufacturers of this tire, and is it in general use? Would like the editor's opinion concerning its durability.

How should one make a test to show the amount of current being consumed in operating coil? By placing the ammeter between the screw at base of trembler and the upright holding adjusting screw, thus cutting out the trembler, I find the ammeter always reads the same as is shown in testing the cells, so conclude it is not the correct method. My machine consumes an enormous number of cells. Placed another coil on it, but the tremblers on the new coil were so stiff that none but brand new cells seemed able to operate it at all, and these only in a very imperfect manner. Would it be advisable to grind down or weaken these tremblers, or is it probable that the trouble lies in the internal construction of the coil, which is so made that each unit contains two cores, i.e., two primary and two secondary windings?

Should not an exhaust valve seat more than 1-16 inch on the valve seat? The valve has nearly 1-4 inch bevel, but seats only on the very edge, and I am able to get but little compression in the corresponding cylinder, although cylinder wall and piston is in good condition. It looks to me like faulty construction, but the makers of the machine will give me no satisfaction. I have been told by repairmen that a larger valve will have to be used and a new seat bored, since the small valve has ruined the old valve seat.

Is there on the market any cable dressing which will prevent the cables of a cable-driven machine from slipping? The makers of the machine guarantee in their catalogue that the cables will not slip, but this is not true, as the makers well know, for they have printed instructions to send owners of their machines, when they begin to kick, telling them to sprinkle cables with ashes or rosin—a pleasant pastime on a muddy road.

Glyndon, Minn. L. M. LOWE, M.D.

We are under the impression that what Mr. Morrison had in mind is what is known as the "Bailey tread," the shoe of the pneumatic tire being molded in series of round, flat-topped projections, which give it a better grip on the road, particularly where the surface is slippery. Quite a number of the tire manufacturers list tires with these treads.

Connect the ammeter in series, i.e., simply disconnect the primary wire leading from the battery to the coils and place the ammeter in the gap thus made, connecting the wire to one of its terminals and touching the coil terminal with the connection of the instrument. The motor should be running while the test is being made, as a test made with the motor stopped is no indication of what the consumption may be. A properly designed and adjusted coil should not require more than .5 to .7 ampere to operate it. Write the makers of the coil for information, stating the nature of your trouble, as each type has its peculiarities.

We believe it is customary to make exhaust valve seats at least 3-16 to 1-4 inch wide. It looks to us as if the repairman's diagnosis was correct. There are numerous dressings on the market, intended to prevent leather belts from slipping, but we do not know that there is any compound of this kind that is made for the same purpose where cables are concerned.

### FURTHER DATA ABOUT A MOTOR.

Editor THE AUTOMOBILE:

[1,291.]—In using the dimensions stated in letter No. 985, in your issue of November 28, 1907, will you please tell me what the compression would be, and also the horsepower and the speed of the engine?

Worcester, Mass.

Assuming the combustion chamber to represent 30 per cent. of the total piston displacement of the motor in question, the compression (gauge pressure) would be slightly over 70 pounds to the square inch, or about 85 pounds absolute. The indicated horsepower would be 20 in round numbers and the speed 1,500 r.p.m.

F. BALL.

### EXPLANATIONS ARE NOW IN ORDER.

Editor THE AUTOMOBILE:

[1,292.]—Kindly explain the following, which strikes me as very peculiar and somewhat disconcerting to the fellow who is just trying to find out. About a year ago I bought an ammeter of French make, which reads up to three amperes, by tenths. I have used this when adjusting the coils on my car, adjusting each unit until it showed .7 ampere. Running the engine would show a consumption of .4 ampere. That to me was satisfactory, the engine ran well and I got good long life from my dry cells.

Some weeks ago I loaned my ammeter to a friend. He used it in adjusting his coils, and was so well pleased that he spent some of his good money and bought a similar meter. This was of American make, and showed 4 amperes also by tenths. He took this home and was surprised to find that the adjustment which showed, under continuous current, .7 ampere with the French meter only showed .5 with the American. He brought the meter to me and my results were the same, and on my car when the engine was running the French meter showed .4 and the American .25. Note that in every case the American meter showed the lowest consumption.

Now comes the surprising part of my story. Being anxious to know which meter was more nearly correct, I carried both into a well-known electrical supply house and asked if they could test them for me. They were very obliging, and made a test in my presence, which showed, in amperes:

Their Standard	The French Meter	The American Meter
1.00	1.00	1.25

This was very good for the French meter, but reversed the position of the two, making the American read the higher. This did not satisfy me, so I took both meters to a well-known manufacturer of electrical meters and had him make a test. His results were as follows:

Standard	French	American
1.00	.85	1.10
2.00	1.80	2.30
3.00	2.80	3.50

This also makes the American meter read the highest.

The voltage on my car comes from four dry cells in series, and as they have now been in use for some time it probably does not exceed five. The first test was made by using one dry cell (fresh) and was probably one and one-half volt. The second test was made with (I believe) one-half volt. I mention these as they may have had some bearing on the matter.

However, I am "all at sea" and will appreciate any explanation which may come to hand through "Letters Interesting and Instructive" as to why the meter showing the higher reading under test shows the lower reading in actual service.

New York.

"FOUR-CYLINDER SAIL."

Assuming that tests of the different ammeters were always made under the same conditions, which was doubtless the case, we must confess ourselves to be equally "at sea," and, accordingly, invite explanations from those of our subscribers who think they can throw any light on the subject.

### A CHANCE FOR MAKERS TO EXPRESS OPINIONS.

Editor THE AUTOMOBILE:

[1,293.]—If I may have the necessary space in your next issue, I should like to ask the following questions of the various automobile manufacturers and others:

First: I should like to have some of them inform me as to why it is that there are not more of the high grade cars driven by air-cooled engines? Is it a case of prejudice, precedent, or inability to see the good and efficient work done by the greater part of the air-cooled automobiles now on the market? I realize that it would be hard to convince the entire buying public of the good features of the air-cooled engine, or any other entirely new feature of construction, for any given make of car all at once, but if some half-dozen or more manufacturers of high grade water-cooled cars would put out an air-cooled engine as an option, and push that option, it would not be a great while before the major portion of the cars sold would be equipped with air-cooled engines.

I should like to hear from some of the manufacturers of high grade cars as to their views of the matter. FRED B. FAY.

Worcester, Mass.

The frequency with which "air-cooled" questions have come to light within the past few weeks leads us to place the following opinion on record, and we trust that manufacturers of air-cooled cars will correct us, if necessary, or supplement it by their



own views. In reality, the following is a statement of fact, and not merely an opinion. The air-cooled car has shown itself to be eminently practical, highly efficient, more economical in fuel consumption than the water-cooled type and fully as reliable as the latter. A great number of the victories in automobile contests held in this country stand to the credit of air-cooled cars. Regarding the prevalence of the water-cooled type, we think the matter can be most easily explained by the fact that the average manufacturer of automobiles is in business to make and sell cars, and though he may have very decided opinions of his own, he is quite willing to make what the public wants. In other words, it appears to be more difficult to sell air-cooled cars, and makers generally prefer to work along the line of least resistance rather than undertake an expensive educational campaign. The water-cooled car was already on the scene in numbers before the air-cooled began to make any impression, so that the former became the fashion, and its sway is hard to dispute. This is doubtless a basis of what may be termed a prejudice against it. Because A, B and C have bought water-cooled cars their friends do likewise, and, as the owners of air-cooled cars are in the minority, their influence is not so far-reaching. The air-cooled motor needs no defenders, as its record speaks for itself.

### POOR WORKMANSHIP DECREASES EFFICIENCY.

Editor THE AUTOMOBILE:

[1,294.]—I am a subscriber to your valuable paper, and would like to have the following answered in "Letters Interesting and Instructive": Would it make any material difference in a two-cylinder opposed motor of 18 to 20-horsepower if, through imperfections in workmanship, the pistons did not come up into the explosion chamber within 1-8 of an inch of where they were originally designed to? I hold that it would, but my foreman says it would not. Which is right?

Also, I would like to ask about the Renault device for starting from the seat. As far as I could see from cut in the March 12 issue of "The Automobile" there was no provision made for backward motion of the shaft. Should think in that case that the motor would do considerable damage in case it should backfire.

A. K. W.

This would lower the compression of the motor according to the ratio that the distance in question bears to the length of the combustion chamber, as originally designed. It may be that the loss is actually negligible in the motor you speak of, though a brake test would quickly reveal it. Very small errors of construction are fatal to the efficiency of a motor when they affect its compression. Your foreman must have a very peculiar idea of the principles of the internal combustion motor, as if 1-8 inch loss would have no effect whatever, it would follow logically that any amount of error here would not reduce the motor's efficiency, and it would work equally well even if there were one or more inches added to the length of its combustion chamber, regardless of the designer's ideas in the matter. It may be that the dimension in question strikes him as being so small that it could not have any appreciable effect, one way or the other, but in a small, high-compression motor, such as is used on a motorcycle, it would mean a loss of fully 10 per cent., or more.

You evidently did not read the description of the Renault self-starting device very closely, as it reads, in part: "The pinion G, the rotation of which commands the crankshaft, is provided with a free-wheel ratchet device, shown in the separate drawing." This provides both for the disengagement of the self-starting device when the motor gets under way, and for taking it out of engagement should the motor "backfire."

### IS ANYTHING GAINED BY USING HOT AIR?

Editor THE AUTOMOBILE:

[1,295.]—Please answer the following, through your "Letters Interesting and Instructive": I have a Schebler Model F carbureter which can be heated by the exhaust by putting on some pipe. Is anything gained by heating the mixture while passing from the carbureter to engine in cold or warm weather?

I would say in regard to letter No. 1,218 that I have had trouble

much like he has. To overcome it I put several thin pieces of leather between the float and the lower end of lever to which the float is fastened, so that it does not allow the gasoline to raise so high. Care must be taken that the float does not touch on sides of the float chamber. I also lowered the gasoline tank and raised carbureter, and everything is working right now. Have had no trouble with the carbureter since.

Could you tell me if a car registered in Alberta can tour in Montana and North Dakota without going to the trouble of registering in each State? If you have the laws of these States, please give most important parts in your answer.

High River.

E. H. SCHROEDER.

Ease of starting is gained by heating the mixture and condensation is prevented in cold weather, this being the case where the manifold is unusually long. The cold mixture is more effective, however, as the colder the air is the denser it is, and, consequently, the more oxygen it contains. Many foreign cars are so equipped that either hot or cold air may be used at will, while others circulate the cooling water round the carbureter to keep it warm, this being found on some American cars as well.

The Montana law, which became effective early in March, 1905, does not provide for registration, so that unless it has been amended in the interim, a foreign number is good there. This is also true of the North Dakota law, passed in the same year. The principal sections of both laws are: "Speed rates (Montana, 20 miles outside, and 8 miles an hour in cities; North Dakota, 15 miles outside, 8 miles inside, and 4 miles an hour on city crosswalks when persons are using same), Duties upon meeting horses, Definition of motor-vehicle, Punishment for violations, Muffler, lamps, bell, etc., Laws of the road," etc., which are virtually the same in both, and correspond to those generally embodied in laws of this kind throughout the United States.

### SUBSTITUTING SILVER FOR PLATINUM.

Editor THE AUTOMOBILE:

[1,296.]—I have an Indian motorcycle, 1906 model. I lost the platinum out of the circuit breaker and the platinum is burnt or worn off the screw. Do you think that silver is a good substitute for platinum?

C. C. M.

Stockton, Cal.

If silver were an effective substitute for platinum it would be generally employed by manufacturers, as the cost is but a fraction of the latter. It will give good service in an emergency, as in case where the platinum contact has dropped out, or worn away entirely, but it is not proof against oxidation to the same extent, and will wear away much more rapidly, as it fuses readily.

### WHAT CAR HAS THESE FEATURES?

Editor THE AUTOMOBILE:

[1,297.]—Is there an automobile manufactured in the United States that uses both the friction transmission and two-cycle motor?

JOS. H. STRAWN.

Star Junction, Pa.

We are under the impression that such a car is built in this country. If we recollect aright, it is of the high-wheel, or "buggyabout" type, but we cannot recall its name at the moment. If any of our readers can help us out, we will be pleased to publish their answers for the information of the inquirer.

### HOW MUST BRAKES BE APPLIED LEGALLY?

Editor THE AUTOMOBILE:

[1,298.]—Will you kindly furnish me with the following information: Is there a law in any State requiring the application of brakes to the wheels direct on motor-driven vehicles? If so, in what State, and where can I secure a copy of the ruling?

Chicago, Ill.

J. A. HERZOG.

While a majority of the so-called motor-vehicle laws of the various States provide that automobiles shall be equipped with breaking devices, we do not know of any that specify in detail just what part of the car the brakes shall be applied to. Much of the proposed legislation of earlier days was of an extremely weird brand, and in it many of the Solons tried their hands at

specifying just how a car should be built, some thinking that the machine should be so constructed as not to be able to exceed a certain speed limit. None of these ever became law. If any of our readers are better informed on this subject, we should be pleased to hear from them.

**EXPLAINING THE CARBURETER DIFFICULTY.**

Editor THE AUTOMOBILE:

[1,299.]—Every time a tire "gets bad" or "blows out" it is immense satisfaction to know exactly the service it has given. Without a written record an estimate is either unjust to the owner or the manufacturer.

First, if the tire does not bear a serial number for identification, it can be permanently marked on the inside, using a wet sponge plus a heavy indelible pencil. The water will soak the marks deep into the canvas.

Next, for each tire numbered, prepare a large card similar to the following form, upon which the whole performance of the tire can be intelligently noted. For example, the first line to be the descriptive:

No. 100. Kind, 36 x 5, smooth tread. Bought of..... 1/1/08. Cost, \$75.00

	Date	Wheel	Miles Registered	Total Mileage	Remarks	Total Cost
Put on....	1/15/08	Right rear.	1,000	.....	Kind of car.....	.....
Removed..	4/1/08	.....	5,000	4,000	To factory for retreading, \$20.00.....	\$95.00
Put on....						
Removed..						
Etc.....						

Using heavy pasteboard cards and an indelible pencil will furnish a complete, accessible, and permanent record of each and every tire, and can be easily filed in a prepared rack. Believe that the tire manufacturer could please many of his customers by having a neat form printed similar to the above, as well as an advertisement for him.

M. G. AUGSPURGER.

Cincinnati.

**ABOUT THE DEALERS AND THE SUPPLY HOUSES.**

Editor THE AUTOMOBILE:

[1,300.]—In a recent issue of "The Automobile," I noticed an article regarding agent complaining that factories were selling cars direct to the consumers and sign contracts with any Tom, Dick, and Harry, in which case they used to form a club for buying a few cars at a time so as to fulfill the contract. Now, I think that agents and retailers also would have a reason to complain about supply houses selling supplies by mail direct to consumers. I, most of the time, found that when a consumer needs any accessories or supplies, he will ask for a catalogue price and then ask for the discount on it. In most cases, if they do not give him the discount that is given by the supply house, those parties will send to the supply house themselves and order what they want. I do not see any reason why the supply houses should limit themselves to do business with bona fide dealers only, as I am almost certain that the public would be buying just as much, regardless whether they could get it from the supply house or from their local dealer. Now, why could not retailers in automobile supplies, and garagemen, form an association, in which case each member would have to prove himself to be a dealer and running a garage or repair shop as a business. If this could be realized, it would be easier for the supply houses to know with whom they deal, and it would also be easier to keep a standard price on each and every article. As it is, at the present, with no fixed price on the products, one dealer will charge more and others less than the catalogue price, and I believe this to be the cause that the motoring public generally prefer to send to a supply house for their supplies, where they know that there is only one price.

I would like to hear the opinion of others on the same subject, as I really believe that sooner or later something must be done in this line so as to better regulate the trade.

ARTHUR BEIJER.  
Phillips, Wis.

**CONCERNING THE QUESTION OF TIRE HEATING.**

Editor THE AUTOMOBILE:

[1,301.]—"Pneumatics," in his letter of March 26, on the heating of tires, goes at the subject in the right way, but I should like to take exception to some of his reasonings. He concludes that the heating is probably due to compression of the air in meeting obstructions, because "the causes of this super-compression follow one another with such rapidity that the attendant expansion has but slight cooling effect." This is rather hard to follow. There

must be as much expansion as compression, no matter what the speed, and it is an invariable rule that as much heat is lost in expansion as is gained in compression. On the other hand, I believe that a large part of the heat is caused by internal friction in the shoe—a possibility which "Pneumatics" dismissed without much consideration. Rubber is not perfectly elastic; consequently a large part of the work done in distorting it is transformed into heat. My conclusion would be that the heating is due both to internal friction and road friction, the proportion, of course, depending on the smoothness of the road.

G. H. GODLEY.  
Cambridge, Mass.

**DR. HARD ANSWERS HIS CRITICS.**

Editor THE AUTOMOBILE:

[1,302.]—My critics are partly right. Billed down into a few words, a car is retarded most when the drive wheels make the motor run at the highest speed. But the all-round and most serviceable method of retarding the progress of the car by using the motor for a brake, is to simply cut out ignition and leave the high speed on. The Minneapolis critic requires no reply. The factors of resistance, such as compression, friction, etc., were correctly stated. Old tire casings placed on the wheels, as directed in my former article in "The Automobile" gave better results than any other way of protecting that I have seen, and I am not without experience. This letter will serve to answer the published criticisms, and also quite a number of private communications on these subjects.

Marshall, Minn.

A. D. HARD, M.D.

**EXPLAINING THE CARBURETER DIFFICULTY.**

Editor THE AUTOMOBILE:

[1,303.]—In answer to letter No. 1,218, I would suggest to him that he reduce his air in same way I did on Schebler carbureter, the air opening just above the valve is, I judge, about one-half by three-quarters. I took a small piece of tin and inserted it down inside air intake. Closing that opening to about 1-4 by 3-4, drilled small hole through pipe, fastened with small bolt, so it could not get out of adjustment. My motor will start now 8 times out of 10 on compression. Previous to my doing that I had same trouble he complained of. Was evident to my mind that the air valve did not begin to work until you speed up motor. Consequently, was getting too much air to start motor properly, or could not start motor at all until I cranked my head off.

McKeesport, Pa.

A. C.

**ANOTHER EXPERIENCE WITH DECARBONIZER.**

Editor THE AUTOMOBILE:

[1,304.]—Noticing in your "Letters Interesting and Instructive" an article on "Lubrication," and in letter No. 1,253, J. L. Williamson stated he believed he was the only one using decarbonizer in his oil. Last fall I had trouble with dirty and greasy plugs, and tried several things, but had to clean my plugs every day to get any kind of service until I tried decarbonizer in the cylinders and found it helped. Since November I have used a tablespoonful in each cylinder every two weeks, and also about 10 ounces of the same in every gallon of lubricating oil. As I drive a Winton and have no splash system, have had my plugs out once since November and found them clean but slightly colored, but never touched them.

Davenport, Ia.

H. LEASE.

**WHY THE GASOLINE DRIPPED CONSTANTLY.**

Editor THE AUTOMOBILE:

[1,305.]—In answer to letter No. 1,218, I should think your trouble is caused by a leaky carbureter, either from the setting of the float, or from the seat of the needle valve, thus allowing the gasoline to collect in the bottom of the carbureter. This would naturally drip out, as there are some small holes in the bottom of the Schebler carbureter—these must be stopped up.

When the engine is cranked it draws a lot of gasoline to the cylinders, which is too rich to explode, and thus the cranking continues until this gasoline is got rid of. I had this same trouble, which was remedied by regrinding the needle valve to its seat.

Providence, R. I.

E. T. P.

**CARBON DEPOSITS CAUSED THE TROUBLE.**

Editor THE AUTOMOBILE:

[1,306.]—I note in letter No. 1,277 that a reader asks if any other reader has had the same trouble F. R. Zeigler complains of in the March 12 issue. I have had the same trouble with my Ford. I found my trouble was carbon deposited in the carburetion chamber, and I found heavy carbon deposits around the valve seats, and after removing the carbon my engine ran like new.

Uhrichsville, O.

J. W. LYTLE.

# BIRTH, DEVELOPMENT, AND FUTURE OF THE SIX

By C. C. HILDEBRAND.

ENGLAND has been generally credited with being the birthplace of the six-cylinder idea, but the records seem to indicate that the first car having a six-cylinder vertical engine was the "Gasmobile," which was built in this country and exhibited at the New York show of 1901. A search through the back files of the English trade papers does not disclose any word concerning the six-cylinder Napier previous to October, 1903, nearly two years later. The Standard Motor Construction Company built their first six-cylinder engine in 1902, and had it running in a boat in the spring of 1903. About this time two other American manufacturers built a six-cylinder car, but these were not successful nor satisfactory, and hence discontinued.

Although America can probably claim the honor of having made the first six-cylinder, the American makers were so sure that the one and two-cylinder cars had all the cylinders needed that they failed entirely to appreciate the value of the multi-cylindered engine. Therefore much of the credit for the present popularity of the "sixes" abroad must be given to the Napier company and the present popularity of the "sixes" in this country must be given to the Stevens-Duryea Company.

J. F. Duryea, who built the first successful automobile in America, has had vastly more experience than any other designer in this country. He realized long ago that the six-cylinder type eliminated intermittent torque, dead center and lack of balance—the three defects of the one, two and four-cylinder engines. The Stevens-Duryea Company, believing that the acceptance of the six-cylinder car in higher horsepowers would be general as soon as the public realized its advantages, disregarded the universal antipathy to "sixes" which has existed and began the development of a six-cylinder model far in advance of other makers.

The manufacture of the Stevens-Duryea "Big Six" was begun in 1905, which makes the Stevens-Duryea Company the first American manufacturer not only believing in the six-cylinder idea, but backing up their belief by manufacturing sixes and ordering material for over half a million dollars. The success of the "Big Six" was instantaneous, and the result of this success was evidenced by five American manufacturers making sixes in 1906. In the foreign field four manufacturers were building sixes. The design of the "Big Six" that was made in 1905 was so perfectly worked out in the drafting room that no changes in mechanism have been necessary up to this writing.

In the meantime the obvious superiority of the six-cylinder car resulted in a heavy demand for this type, and the Stevens-Duryea Company had produced the "Light Six" and were marketing both the "Big Six" as well as the "Light Six" while other makers were hurrying designs and testing out new six-cylinder models.

In 1907 the six-cylinder idea had so spread and manufacturers had so rushed to meet the increased demand for them that we find a total of seventy-seven foreign makers producing six-cylinder cars and many others working on them. In America there were exhibited forty-six six-cylinder cars at the New York show in 1907, and there are at the present time twenty-seven American concerns manufacturing six-cylinder cars. The fact that the people demanded sixes had the effect of bringing the manufacturers to time, and they ceased opposition and designed sixes.

At this time the Stevens-Duryea Company had hundreds of sixes in the hands of owners giving entire satisfaction. Some of the advantages of the six:

- It runs more slowly on high gear.
- It picks up speed faster and more easily on the throttle.
- It has much less vibration.
- It runs with a silence unknown to the four.
- It makes gear shifting almost unnecessary.
- It is decidedly better for hill climbing.

A thorough test of the Stevens-Duryea six through crowded streets, through stretches of sand, and over difficult hills will easily prove these statements to be true.

All mechanical engineers admit that the six has more flexibility than the four, on account of having a more perfectly balanced engine, and it is this perfect balance that produces absence of vibration and smoothness of running. This flexibility is also brought about by the power stroke overlapping each other. Before the first cylinder has stopped delivering power, in fact when the piston is about two-thirds of the way down, the second cylinder begins, and so on. This means that even when the engine is running very slowly the power is absolutely continuous, and that during three periods in each revolution two cylinders are working at the same time.

In the Stevens-Duryea sixes the unit power plant and three-point support are used, which are so designed as to secure unvarying alignment between the various points of the power plant, and if there is one thing that spells failure for a six-cylinder car it is to have the car so built that the engine and transmission are exposed to every twist and bend and strain that come with traveling over this country's strenuous roads.

At the present time there are eight hundred and fifty-eight Stevens-Duryea six-cylinder cars in use from Portland, Me., to Portland, Ore., and from Minneapolis, Minn., to Mexico City, Mex., all of which are giving entire satisfaction. It has been the experience of the Stevens-Duryea Company that anyone who has ever driven one of their sixes will never go back to a four, except for a smaller car, and this fact strongly shows the tendency of the future. They believe that anyone purchasing a four-cylinder car of more than 40 horsepower and paying more than \$2,750 for it, should buy a six. The single-cylinder, two-cylinder and four-cylinder engines will be used indefinitely to fill that demand, and it is the concensus of opinion of Stevens-Duryea owners, a great many of whom have owned two and four-cylinder cars and have driven in and are familiar with certain four-cylinder types higher in price even than our Model U, that after every such experience they have invariably returned to the six-cylinder with added enthusiasm. The flexibility, smoothness and surprises of the six-cylinder engine surely have brought the enthusiastic and exacting automobilist more than ever to the realization of his dream.

Unless an extraordinary revolution in gas engine design takes place, the six-cylinder engine will continue to represent the best in motoring, as it means smoothness, silence and ease of operation to a degree unknown in any four-cylinder car.

## FOR PRESERVING THE HORN BULB.

A stitch in time certainly saves nine with the rubber bulb of the average horn, says the *Autocar*. Most of them have a raised ring in the middle of the bulb just where the thumb of the driver comes, and very soon at this spot the rubber gives way. As we have pointed out before, the bulb can be mended quite well with a solutioned patch, but this is apt to give way from time to time. The best method is to deal with the bulb before it commences to leak. The first thing to do is to fill up the space inside the raised ring with a solutioned disc of rubber. Then solution another ring of rubber round the raised ring, about half an inch wide, and on top of this place still another piece of rubber. If this work is carefully done, it results in the part of the bulb which is most subjected to wear being greatly strengthened, and they will last for a couple of years without renewal. The operation may be simplified by paring the ridge away with a sharp knife, until flush with the bulb, then placing a large patch right over the top of the entire bulb. There is no better material for the purpose than an old inner tube.

# Skyward in a Northern

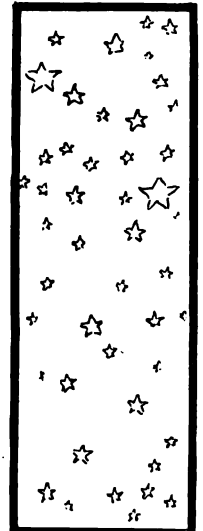

A Five to Twelve Per Cent. Grade Marked the Way Up Mt. Hamilton.

JUST twenty-seven miles east of the beautiful city of San José, in the sunny land of California, old Mt. Hamilton rises up in solitary splendor a sheer 4,409 feet above the sea level. Capping it, much like a monk's tiny skull cap, is the famous Lick Observatory, known the world over for its great telescope, its remarkable photographic apparatus and appliances for making pictures of the heavens and their celestial bodies, and for its marvelous instruments for recording the time and velocity of the wind, atmospheric conditions and seismic disturbances.

Thousands visit the Lick Observatory yearly and pay tribute to Mt. Hamilton in enthusiastic expressions, marveling at its grandeur. Few, however, have experienced the sensation of flying up its dizzy heights as did John D. Swan in his Northern touring car, February 22, of the present year. But Mr. Swan's story is best told in his own words:

"Leaving San José, decked in gorgeous flowers, as it always is at this period of the year, a light breeze fanning the slender giant palms that line each side of the road we headed our Northern across the level roads, four miles to the foot hills, where the first grade was reached. The road was as smooth as a city pavement. As far as the eye could see, fruit, orchards in bloom dotted the rolling hills, while here and there a little brook sparkled in the morning sunlight. The whole scene was enchanting. To fly swiftly along, up and down grades, across miniature bridges and around curves, much as if the car was being drawn by some distant star or pushed over the hills by an unseen hand, provokes sensations wonderfully exhilarating and joyous—feelings that can hardly be expressed in words, but which every autoist who takes such a trip can well understand.

"The last stage-station was reached before we knew it. Thirteen miles away and four thousand feet above us the great Observatory shone, looking for all the world like a lilliputian monument. From this station our quiet car glided down a slope to the valley below, little thinking that immediately on the other side the real climb commenced, and

that, from there on, the smoothly running motor under the hood must push the car and its passengers up and above the clouds.

"The road led on round and round the mountain, the grade meter on the dash indicating at times a grade ascent of 12 per cent. Never did it drop below five or six, although the high-speed clutch of the car was in, practically sealed, because from the time the car left San José it had not been pulled out of position. Not an inch of the road was level not a yard straight; the road wound in and out around rocks, skirting precipices and cañons, for all the world like a giant serpent with its fanged head in the skies and its tail in the valley below.

"About half way up the mountain we felt the first effects of the perennial snow, the road on the north side being very slippery, and on the second winding the snow made its presence felt in earnest. Not only was it much colder, but huge drifts appeared on either side of the twisting road. The snow is always particularly bad on the mountains of California in February. The road is kept open by shovelers, and the Northern never wavered in its progress up the winding way to the final spurt up the 12 per cent. grade to the mountain crest. The road in this particular spot is covered with broken stone, made slippery by the constant moisture, and we learned from the keepers of the Observatory that this had proven the 'last straw' for many an auto which had striven gallantly to reach the dizzy height which the Observatory occupies.

"Our car glided swiftly up to the very door of the Observatory, and for the first time I pulled out the clutch and brought the car to a stop. The kindly guide at the Observatory looked over the Northern in amazement, and informed me that on only one or two previous occasions had a car been driven to the door of the Observatory, and that the record time was held by a racing machine which had dashed up the mountain in the heat of summer over dry roads in 1 hour 17 minutes. The 24-horsepower Northern had not been driven against time, but when watches were referred to it was found



At the Mountain's Top in Front of Lick Observatory.





Northern Car In Mt. Hamilton's Perennial Snow.

that the long non-stop run had been made in just 1 hour 50 minutes from San José, and this at a constant speed without changing gears or a single stop. Mrs. Swan accompanied me on the trip and was much impressed with the beauty of the scenery and the glorious possibilities of exploration which the automobile offers.

"The old bewhiskered stage driver who approached our car, clambered down from his heavy stage, announcing his guests to the guide, and came over to look at his apparent competitor standing before the Observatory door. After I had assured this quaint character that I did not intend to compete with him in his passenger service and answered his many questions, I asked him why he did not drive four or six horses, instead of two. The driver looked at me as if contemplating whether or not I was joking with him, and, seemingly convinced that I was in earnest, answered: 'Wal, you see. It's like this. In the first place, four horses would cost twice as much as two. Then they'd stow away twice as much feed and take twice as much looking after, and what's the use of having four when I can do the work with two?' Going down the mountain, after we inspected the Observatory carefully, we had an opportunity to test the efficiency of the brakes."

### A CLUB RUN IN CALIFORNIA.

SAN FRANCISCO, April 1.—The first scheduled event of the season under the Automobile Dealers' Association of California took place last Sunday, and lay from this city to the summit of Mt. Hamilton and return. Most of the cars left on the 7 o'clock boat, but all day they left the city for a run to the blossom district. The run was made down the Oakland side to San José, out Santa Clara avenue to the Alum Rock road, from which on the right branches the Mt. Hamilton road. There was no contest of endurance or speed in connection with the event, which was purely one of a social nature. The distance from San José to the summit is twenty-eight miles, the last seven being characteristic of the entire route, having, in the course of the seven miles, 365 turns. It is a most picturesque trip, over excellent roads. The hills and valley were carpeted with bright green grass, splashed here with the flaming orange of the California poppy, and there with the yellow of the buttercup, while in shadier places were masses of purple and pink. At the foot of the hills and along their bases nestled the symmetrically laid-out ranches and orchards, with their carefully kept-up fields and outhouses. In the far distance could be seen the sparkle of the waters of the Pacific. The day was exceedingly clear, with a bright, warm sun and just enough breeze to carry the scent of the blossoms, hundreds of acres of which looked like blocks of snow. More than fifty automobiles made the run, and, on an average of four persons to a car, fully two hundred persons visited the Lick Observatory, which crowns the summit of the mountain. The run back to San Francisco, from San José, was made on the coast side, over the new boulevard being constructed through the untiring efforts and supervision of R. P. Schwerin.

### INTERESTING TEST OF NEW FRICTION CLUTCH.

After a year's experimenting and study of the problem, Forrest R. Jones has brought out a new friction clutch, which has been termed the "Atorqlim." In a recent shop test to determine uniformity of torque limitation, rapidity of picking up full load and releasing it completely, and the effect of heating on the bearings and other parts of the clutch, the driving member rotated at 450 r. p. m., the "driven" side being held so as to prevent its rotation. The turning force transmitted to the driven side was weighed on a pair of scales, as when using a Prony brake. The adjustment of the clutch was for 105 foot-pounds torque, corresponding to 20 horsepower at 1,000 r. p. m.

During most of the time the clutch was mechanically let into engagement and released, as by a foot lever, at the rate of 170 times a minute. The duration of each full frictional engagement was half the total time between successive releases. Several times during the test, and at the end, the mechanical releasing device was thrown off, and the clutch left in continuous full frictional engagement for five to ten seconds, sometimes fifteen seconds and longer. After running half an hour in this manner, the clutch became so hot that black smoke began to puff out at every release and ordinary machinery oil vaporized rapidly from the outside. This continued till the end of the test, which covered something more than an hour.

The torque limit, as indicated by the weighing scales, did not vary beyond 25 per cent. in the tests where the clutch was left in full engagement for several seconds continuously. When released 170 times a minute, the variation was within 5 per cent., as shown by keeping the scales adjusted so that the beam was lifted each time but did not strike at the top. No adjustment of the clutch was made during the test. At each release the lever arm resting on the scales could be lifted by a slight pressure of one's little finger. An attempt to weigh the drag when the clutch was released was unsuccessful on account of its being so small, except that it was plain that it was within a foot-pound. No indication of wear or injury to any part on account of this test was found when the clutch was taken apart after the test. The originally bright parts enclosed by the friction rings had become thoroughly blued and blackened by the heat. Black smoke continued to come off for more than a quarter of an hour after the opening. The clutch was still in perfect working order.

In earlier trials the friction rings were left annealed very soft in order to see the effect of their cutting and abrasion, and of the resulting chips of metal, on the action of the clutch. It took care of them satisfactorily. More than half a pound of these chips was removed from the clutch just before beginning the test described. The friction rings were, of course, roughened in

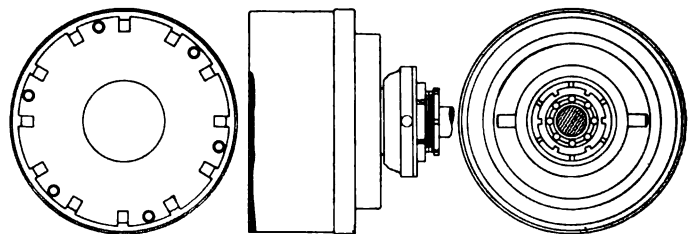

Details of the New Atorqlim Friction Clutch.

the earlier tests, but the internal bearings were not affected at any time, since they are made to withstand temperatures far above that which blues steel. The maximum to which the torque is limited is reduced by pressure on the releasing lever; the clutch can therefore be operated the same as any other type, for more gradual starting than complete engagement gives, and still retains its advantage over the usual types in that the torque is prevented from exceeding the limit determined by the pressure of the foot. The accompanying illustration shows a side elevation of the complete clutch, while at the right is a plan view, the third sketch showing one of its components.

## HOW FARMAN AND DELAGRANGE MADE RECORD FLIGHTS

PARIS, March 25.—One mile 428 yards 32 inches is the world's official flying record, established by Henry Farman, in his Voisin Frères aeroplane at Issy-les-Moulineaux, Saturday, March 21. In reality, the distance is over two miles, for, during the 3 minutes 31 seconds that Farman remained aloft, he made two complete circles round the two flagstuffs planted in the military ground at a distance of 547 yards 8 inches, one from the other. Four times the distance from flag to flag gives the official record; but, as it is impossible for a mechanical bird measuring more than 33 feet from head to tail to swing round as easily as a taxicab, considerable allowance must be made for the turning curves, the preliminary flight, and the final sprint prior to coming to earth.

When the officials of the Aero Club of France planted the two flags at the extremities of the measured track, the monotonous plain on the banks of the Seine was so enshrouded in fog that it was almost impossible to distinguish both flags at once. Farman was ready first, and, after a little preliminary cantering, started from the outermost edge of the ground for one of the flagstuffs, rounded it with but three or four feet to spare, and rushed toward the opposite one. In a few seconds another

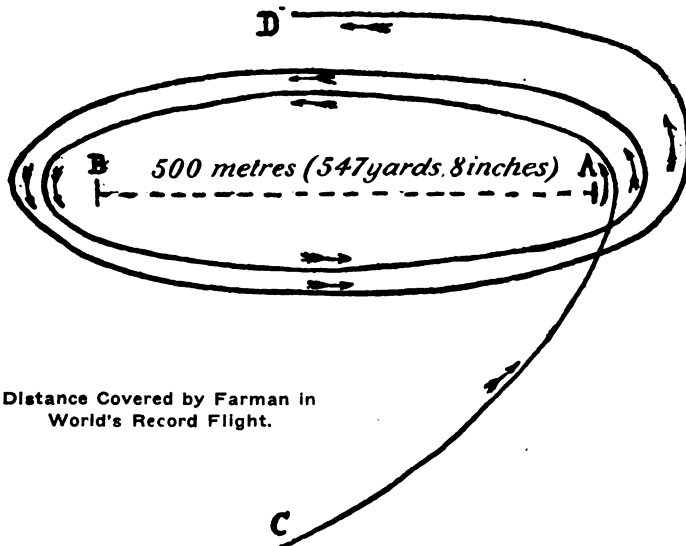

huge circle had been described around the two fluttering flags; but when the official starting point had been crossed for the second time Farman still continued, flying wider afield, and coming to earth gradually at the outside of the ground.

So far as could be judged, only the limitations of the motor prevented a much longer aerial flight. Since winning the Deutsch-Archdeacon prize, Farman's aeroplane has been dismantled and reconstructed on identical lines, with rubbered cloth, manufactured by the Continental Tire Company, this material replacing the former varnished silk covering. The new Renault air-cooled eight-cylinder motor was also fitted, but when experiments were made, was found to need some tuning up, and was dismantled and sent to the factory. It was, therefore, the original eight-cylinder water-cooled Antionette which drove the aeroplane in its world-record flight. Though running without a skip from beginning to end, the Antoinette has the serious disadvantage of possessing a very small quantity of water in its jackets and tanks, and to be limited by reason of weight in the amount of gasoline it can carry. Thus a flight of any length is almost an impossibility unless more fuel is carried.

"Climb in and Fly with Me," said Delagrange.

Leon Delagrange entered the arena at noon, when a little of the excitement attending Farman's victory had subsided. A little preliminary cantering over the ground to the healthy roar

of the eight-cylinder motor, then the signal for an official flight, and 2 minutes 30 seconds later a circle of 1,640 yards had been described. Had Delagrange started first his performance would have been a record, for the previous long-distance flight was one kilometer, covered by Farman on January 13.

Farman had remained an interested spectator of the flight of his friend and rival, and was but a few yards from the aeroplane when it came down. "Climb in, Farman, and I will take you back to the sheds," cried Delagrange. In a second Farman was mounted behind Delagrange for the trip to the sheds.

### Michelin Increases Aero Prizes to \$52,000.

In consequence of Farman's new record, the committee of the Aero Club of France fixed the distance to be covered this year to win the Michelin prize at 12.4 miles. During 1908 the prize may be competed for after April 10, and for the succeeding seven years the dates, distances and conditions will be determined by the French Club. M. Andre Michelin announced that he would increase the total amount offered for these competitions from \$50,000 to \$52,000. For eight successive years the sum of \$4,000 and an artistic cup valued at \$2,000 will be given for the longest flight in France or any country having an aero club affiliated with the French organization. Originally, it was intended to make the first year's distance double that of Farman's record in January, 1908, doubling the distance each year.

For the \$20,000 Michelin prize, an aeroplane with two persons on board must start from any point in the Seine or Seine and Oise department, encircle the Arc de Triomphe at Paris, fly to Clermont-Ferrand, encircle the Cathedral of that city, and descend on the summit of the Puy-de-Dome. The distance from Paris to the Puy-de-Dome is about 220 miles, and must be covered in a time limit of six hours. The Puy-de-Dome being 5,800 feet above the level of the sea, an aeroplane would have special difficulty in making a flight to such a height, owing to the rarification of the air, which, it is calculated, would decrease the sustaining power of the machine by at least one-sixth. Resistance would necessarily be less, the machine operating in a fluid of lesser density. Ten years are allowed for the accomplishment of this long-distance flight.

### Details of Farman's Nearly Serious Accident.

PARIS, March 28.—Henry Farman's aeroplane, the modified machine with which the flyer won the Deutsch-Archdeacon prize, is no more. Farman was training on the Issy-les-Moulineaux ground Friday morning, in the presence of a small number of spectators, when, on making a turn, the left wing of the aeroplane came in contact with the ground while traveling 30 miles an hour. It collapsed under the blow, throwing the pilot violently from his seat. Farman lost consciousness, and is only able to give a meager account of what happened. It is his opinion, however, that he attempted to turn too near the ground, at a height of 2 to 2 1/2 yards, the inclination of the machine causing the lower part of the left wing to touch. It is also extremely probable that, at the moment of turning, the machine was driven still nearer the ground by a gust of wind.

Louis Bleriot, who had been timing Farman's attempt, rushed to the spot immediately. Farman was lying face downward, his chief injuries being to the face and mouth. Upon being carried into one of the temporary sheds, he regained consciousness, and was taken home in an automobile. Fortunately, no part of the aeroplane, or its motor, fell upon him, and it is to this fact that he owes his life. The aeroplane was completely destroyed, but the Antionette motor is intact. Farman will probably be out again within a week.

### To the South Pole by Auto Sleigh.

Automobile sleighs have come to the fore in such numbers for the purpose of Polar exploration that a meeting was recently

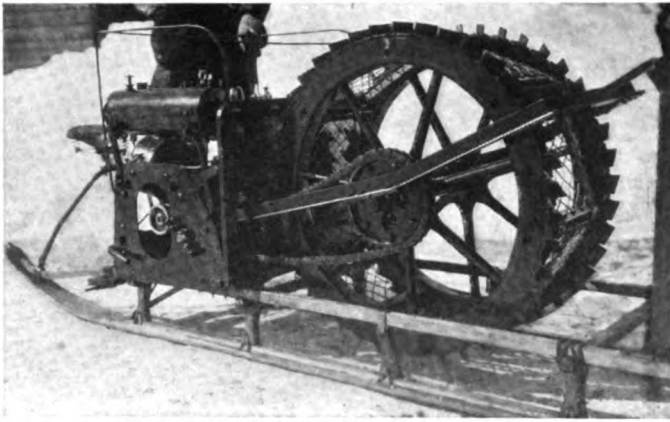

Dr. Charcot's Auto Sleigh for Polar Exploration.

held on the Col de Lauteret, in Dauphine, to try them out. One of the explorers present was Dr. Charcot, who will head an Antarctic expedition, sailing on the *Pourquoi-Pas*, August 1 next. The type of sleigh he will use is shown by the accompanying photograph. It consists of three distinct parts, comprising the sleigh proper, which is of Norwegian build; the power plant, placed at the rear, and entirely protected from the snow; and the propelling wheel. The motor is rated at 23-4 horsepower, and the transmission provides two forward speeds, enabling the sleigh to travel at four kilometers an hour on the low, and eight on the high. The propeller consists of a wheel with two rims placed 28 centimeters apart and mounted on the same felloe, each being provided with grips designed to take hold of the ice.

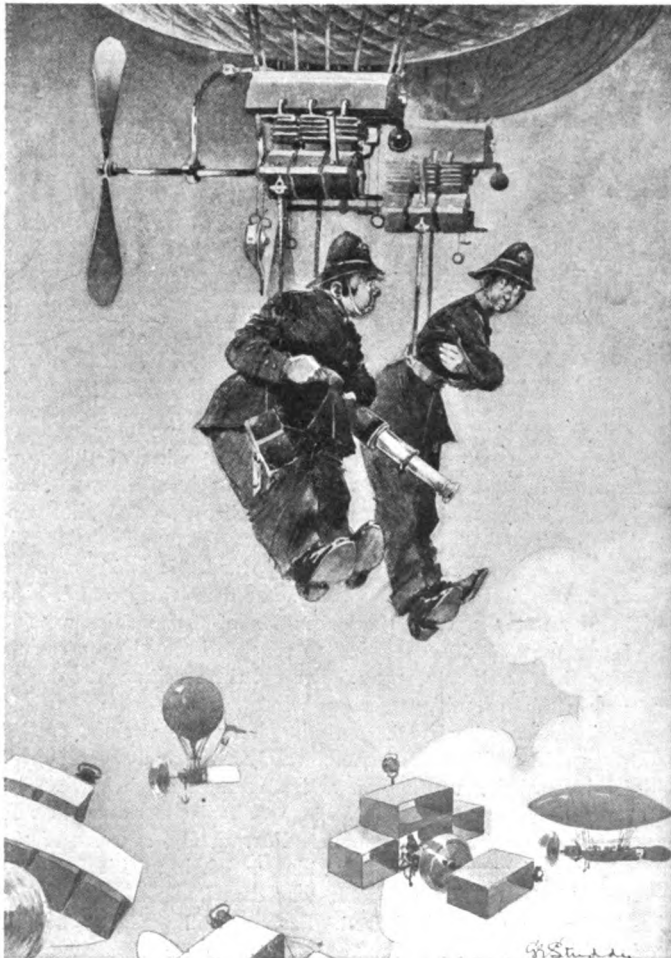

On Their Mettle—From "The Car" (Eng.).

P. C. Trappe (aeroplaintively): "Flings is fair rotten! 'Ere I've been 'idin' in a cloud for three hours an' ain't nabbed one of 'em!"  
P. C. Spotte (ditto): "Nor me, neither. Strikes me every balloonatic knows the clouds 'as got a 'copper' linin' nowadays!"

## THE AUTOMOBILE CALENDAR.

### AMERICAN.

#### Shows and Meetings.

- Apr. 4-11.....—Pittsburgh, Pa., Duquesne Garden, Annual Show, Automobile Clubs of Pittsburgh. Thomas I. Cochran, manager.  
Apr. 16-18.....—Memphis, Tenn., Automobile Show, Memphis Automobile Dealers' Association. William Bruce, secretary.  
Apr. 21-23.....—Louisville, Ky., New Coliseum, Automobile Show. Hubert Levy, manager.  
June 25-27.....—Detroit, Third Annual Summer Meeting of Society of Automobile Engineers.

#### Race Meets, Hill Climbs, Etc.

- Apr. 11.....—Philadelphia, Roadability Contest to Cape May, Quaker City Motor Club.  
Apr. 24.....—Briarcliff Trophy Race, Westchester County, N. Y. Robert L. Morrell, chairman.  
May 4-5.....—Harrisburg-Philadelphia and Return, 300-mile Endurance Run, Motor Club of Harrisburg.  
May 15.....—Chicago, Algonquin Hill Climb, Chicago Motor Club.  
May 16.....—Hartford, Conn., 200-mile Endurance Run, Automobile Club of Hartford.  
May 30.....—Bridgeport, Conn., Sport Hill Climb, Bridgeport Automobile Club.  
May 30.....—San Francisco, Endurance Run under the auspices of the Automobile Dealers' Association.  
June 24-27.....—Chicago, 1,200-mile Reliability Run, Chicago Motor Club.  
July 6-8.....—Buffalo, National Convention of the A. A. A., and Start of Fifth Annual A. A. A. Tour.  
Sept. 5-9.....—San Francisco-Los Angeles Reliability Run, under the auspices of the Automobile Dealers' Association of San Francisco.  
Sept. 14.....—Chicago, Annual Economy Run, Chicago Motor Club.

### FOREIGN.

#### Shows.

- May 17-31.....—Austria, Budapest Automobile Show.  
May 17-June 2.....—Moscow, Russia, International Automobile Exposition, Automobile Club of Moscow.  
December.....—Paris, Eleventh Annual Salon de l'Automobile, Grand Palais, Automobile Club of France.

#### Race Meets, Hill Climbs, Etc.

- April 1-13.....—Monaco Motor Boat Races and Motor Boat Exhibition, International Sporting Club of Monaco.  
April 25-May 25.....—Industrial Vehicle Competition, Automobile Club of France.  
May.....—Paris, Competition for Agricultural Automobiles, auspices of "L'Auto." (Date to be announced.)  
May 7.....—Sicily, Palermo, Targa Florio Circuit, Voiturette Race, Automobile Club of Italy.  
May 11-16.....—Ireland, Irish Reliability Trials.  
May 1-31.....—Automobile Taxicab Competition, France, Automobile Club of France.  
May 10.....—Sicily, Targa Florio, Automobile Club of Italy.  
May 31.....—Russia, St. Petersburg to Moscow Race.  
June 1-18.....—Reliability Trials for Pleasure Cars, Automobile Club of Great Britain.  
June 14.....—Mount Cenis Hill Climb, for Voiturettes.  
June 9-17.....—Touring Competition for the Prince Henry of Prussia Prize, Germany, Imperial Automobile Club of Germany.  
June 15-19.....—Scotland, Scottish Reliability Trials.  
July 6.....—Voiturette Grand Prix, Dieppe Circuit (Automobile Club of France).  
July 7.....—Grand Prix of Automobile Club of France, Dieppe Circuit.  
July 13-17.....—Ostend, Belgium, International Race Week, Automobile Club of Ostend.  
July 20-30.....—Ardennes Circuit Races and Coupe de Liedekerke, Automobile Club of Belgium.  
Aug.....—France, Coupe de la Presse, Automobile Club of France. (Exact date to be announced.)  
Aug. 29-30.....—France, Mont Ventoux Hill Climb, Vauclusien Automobile Club.  
Sept. 1-8.....—French Voiturette Contest, auspices of "L'Auto."  
Sept. 6.....—Bologne, Italy, Florio Cup Race, Automobile Club of Bologne.  
Oct. 11.....—Berlin, Germany, Gordon Bennett Balloon Race, Aeronautical Club of Berlin.

**EDGE, PUBLICITY-GETTER PAR EXCELLENCE.**

England possesses a publicity expert who stands head and shoulders above the leaders in what is generally supposed to be an American profession, and the land of the Union Jack is in ignorance of the fact. It is because S. F. Edge can always keep himself and the six-cylinder interests he has at heart fully in the limelight without any apparent show of commercialism that he has been accepted in a land where "big drum" methods are usually frowned upon, as the outstanding figure of British motoring. Edge is the winner of the Gordon-Bennett cup—way back in the early days of the century; he is the holder of the world's twenty-four hour record; he is the eternal winner on Brooklands track. But Edge as a publicity man, such a connection never occurs to the Englishman. The crowning point of Edge genius is that whether he wins or loses in a contest, starts in a race or remains quietly at home, he is always, by a happy turn of circumstances, more prominently in the public eye than the man who wins or struggles to win the laurel wreath. Edge has already secured more prominence



S. F. Edge.

and enrolled more fervents for his cars in connection with the French Grand Prix than will the lucky mortal who passes the winning post and is carried up to be presented to some French potentate on the Dieppe course next July. Commanding those happy turns of circumstance is genius. There are plenty of drivers who are not afraid to match their skill against that of Edge; there are many who, like him, have graduated from a bicycle to a racing car; there are just as many who have reached the top rounds of commercialism, but there is no other man who can combine with such qualities an ability to keep the world's tongue continually wagging about Edge. A publicity expert has to retire after his third coup, declared an authority. It is false, and S. F. Edge, ex-cyclist, racing automobilist, business manager and letter writer is daily proving it so.

**WHITE STEAMER GETS WILKES-BARRE PRIZE.**

WILKES-BARRE, PA., April 6.—By the forwarding of a gold medal to the White Company, Cleveland, O., a settlement of the dispute between the latter and the Wilkes-Barre Automobile Club, which has existed since the running of the Giants' Despair hill-climb on Decoration Day last year, has been reached. The medal in question was the first prize in the free-for-all event, which was won by Walter White in a steamer. At the same time an offer for settlement of the dispute over the prize for another open event was sent to Mr. Harper, of Philadelphia, and it is expected to be accepted. When this is done, the American Automobile Association will sanction the third annual hill-climbing contest, which is to be held on Giants' Despair on May 30 next. After the contest last year, the Wilkes-Barre club refused to award the prizes to the drivers of the steamers, and a protest by the latter was sustained by the A. A. A.

**LOUISVILLE TO HAVE AN AUTO SHOW.**

LOUISVILLE, KY., April 6.—Through the efforts of Hubert Levy, of the Kentucky Automobile Company, Louisville is to have an automobile show, which will be held in the Coliseum on April 21, 22 and 23. It will be managed by Mr. Levy, and a large number of representative cars will be staged.

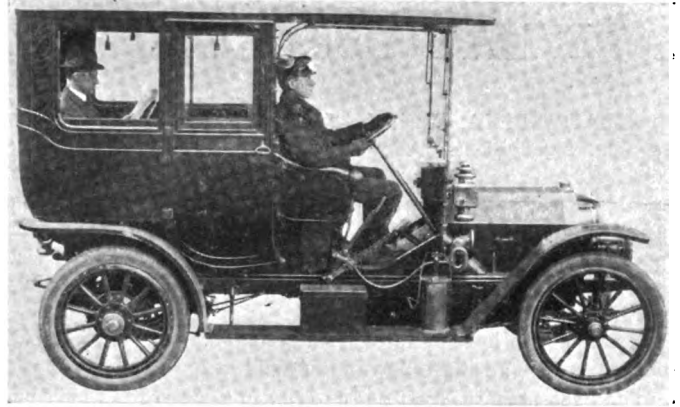

Designer E. J. Moon in 1908 Limousine Moon Car.

**STEARNS WINS ATLANTA CLIMB'S OPEN.**

ATLANTA, GA., April 4.—Atlanta's second annual hill-climb, held recently on the Stewart avenue hill, was decidedly a success, despite a protest over the timing in the free-for-all event and a smash-up at the foot of the hill, when a car ran amuck.

Ed. Inman's 1907 Stearns, which won the free-for-all event last year, and set a record for the hill of 1:06, again captured the free-for-all, covering the slightly longer course in :51 1-4. This time was protested by John F. Kiser, who was second, with his Thomas, in :54. He claimed that the timers at the bottom of the hill caught the Inman car in 1:01. Here are the winners:

**CLASS 1, RUNABOUTS COSTING \$1,000 OR LESS.**

- 1. Buick..... 18 .....William Oldknow..... 1:20 3-5
- 2. Ford..... 15 .....M. C. Hule..... 1:28
- 3. Ford..... 15 .....J. H. Bryant.....

**CLASS 2, TOURING CARS OR RUNABOUTS COSTING \$2,000 OR LESS.**

- 1. Reo..... 20 .....Joe Landers..... 1:29 3-5
- 2. Cadillac..... 20 .....C. E. Travis..... 1:29 4-5
- 3. Ford..... 15 .....J. H. Bryant..... 1:23 3-5

**CLASS 3, TOURING CARS COSTING \$3,000 OR LESS.**

- 1. Pope-Hartford..... 25-30 .....J. P. Grady ..... 1:06 1-5
- 2. Oldsmobile..... 35-40 .....H. J. Lamar, Jr..... 1:11 3-5
- 3. Stoddard-Dayton..... 30 .....L. E. Fain..... 1:13 2-5

**CLASS 4, TOURING CARS COSTING \$4,500 OR LESS.**

- 1. Thomas Flyer..... 60 .....C. C. Rooney..... 1:07 2-5
- 2. Pope-Hartford..... 25-30 .....J. P. Grady..... 1:11
- 3. Ford..... 40 .....J. H. Bryant..... 1:16

**CLASS 5, FREE-FOR-ALL.**

- 1. Stearns..... 30 .....A. L. Almand..... :51 1-5
- 2. Thomas Flyer..... 70 .....J. F. Kiser..... :54
- 3. Pope-Hartford..... 25 .....J. P. Grady..... :59 4-5



Driver Almand in Stearns Winner of Atlanta Hill Climb.



## WHAT ONE CLUB IS DOING FOR GOOD ROADS

PHILADELPHIA, April 6.—The committee on roads, maps and signs of the Automobile Club of Philadelphia, with Powell Evans as chairman and W. O. Griffiths and C. S. Wurtz, Jr., as associates, has prepared a local road book of Philadelphia and vicinity for the use of its members. The club is giving a good deal of attention to the matter of good roads, and is also erecting signboards on all the important routes in the vicinity of Philadelphia.

Explaining its interest in the matter of good roads, the club's committee includes the following material in its little volume:

"The widespread interest and activity in good roads which has of late shown such general strength throughout the country has its origin largely in the growth of automobilism.

"The principal cause of the great European road system was military necessity—the provision of proper highways in surface, line, and grade to admit of speedy passage of troops and armament throughout the year. Highroads so constructed primarily by the State were preserved and maintained in more peaceful times for the different phases of their economic value. Hence

good roads. The excellence of the road system of any country largely measures the progress and intelligence of its people.

"**Second.**—Roads should be constructed and maintained by the community (State, county, or local authority, as the law requires). Main highways between centers should be constructed by the State or National government; crossroads by the local authorities; toll roads should be abolished.

"**Third.**—Roads should be constructed and maintained under a uniform and modern road law providing a common tax on property and its collection. Road work should be prosecuted by the designated authorities, without option to taxpayers of 'working out' the road tax—whereby citizens under inspection of local officials may neglect or evade their obligations by use of their influence as voters.

"**Fourth.**—Roads should be free to all travelers of the community alike under just and equal common conditions and limitations as defined by law. For example: Speed should be regulated by conditions of time and place, so that driving is not to be the common danger, without arbitrary limits and referable to the control possible for each vehicle. Lights should be carried during the night by all vehicles alike.

"**Fifth.**—Roads should be maintained by the community for use of all the people alike, with reasonable wear expected and allowed to admit of proper vehicle control. For example: Reasonable anti-

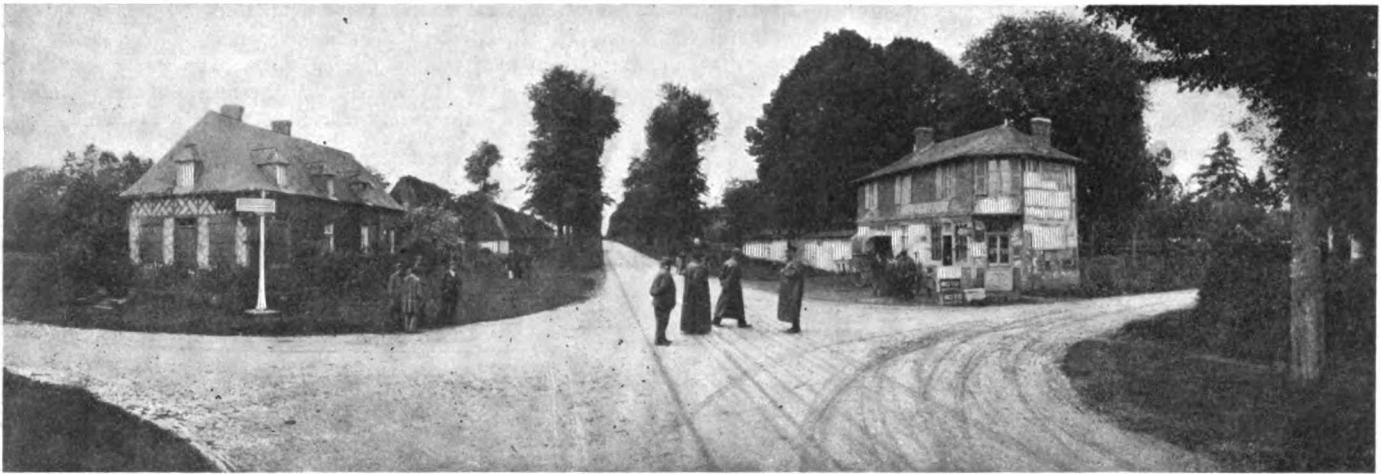

In France Roads Are Built and Kept in Repair and also Properly Marked by Comprehensive Signboards.

there has come down to modern days in many old countries complete road systems and experience practically unknown in this country. The United States was too large, new, and isolated to need or provide like highways prior to the advent of the railroad for transportation, and with this great want filled during the last half century, our road systems have been left to the mercy of careless and fortuitous development and maintenance. The reluctant restriction in traversible radius at any reasonable speed with any sort of load, together with the increase of cost from loss of time and maintenance of conveyance, is only beginning to be understood throughout the country.

"The advent and tremendous increase in the swift and comfortable motor car has enticed an ever-growing number of people into spending their leisure along the highways here and abroad. The contrast has been a revelation, and the sentiment of a few is growing into the action of a host who demand that this rich and beautiful country shall no longer lag behind others of like civilization and less wealth in the provision and maintenance of a highway system second to none anywhere.

"One of the moving reasons for the issuance of this pamphlet at this time by the Automobile Club of Philadelphia is to place before its members and friends the consideration of *principle* and *detail*, which are thought of value in advancing the cause of good roads in this part of the country where our interest centers, and where rapid progress can be made. We hold that:

"**First.**—Civilized communities should construct and maintain

skid tires in winter are as permissible for motor cars as calks in horses' shoes, even if road wear is increased, because such tires are as essential for driving to the common security as roughened shoes on horses. Both are certainly more injurious to roads than types for summer use. All or none of the traffic should be taxed.

"**Sixth.**—Every violation of road law should be notified by proper road signs placed by the authorities as precedent to a possible legal violation. For example: Many minor crossroads are so unapparent to the average traveler (especially a stranger) passing within legal speed as not to be recognized as such for the purpose of blowing a signal. The local authorities charged with the highways know these roads, if any do, and they should be required to erect warning signs at such crossings, giving plain notice to the traveler that a signal is to be blown there, before an arrest and fine for failure so to do is permissible.

"The Automobile Club of Philadelphia hereby announces and favors the above principles. It also counsels its members to fully learn and obey the road use laws, and to comply fully and carefully with all the rights and courtesies of the highway.

"The Automobile Club of Philadelphia, in advancing the work of good roads through the territory naturally falling under its activity, delegated to a Committee on Roads, Maps, and Signs, the work of surveying the highways for the preparation of maps and the location of signboards. This committee found few and inferior maps only partially covering the section, imperfect and unconnected road systems, and few and unreliable signs placed at random. It has for the greater part of a year given as much time as its members could devote to the subject without conflict with their other engagements."

## APRIL DAYS AMONG THE AUTO CLUBS

### PENNSYLVANIA CLUBS HAVE FULL SCHEDULE.

PHILADELPHIA, April 6.—Local automobilists are conditioning their cars for a severe campaign, which opens next Saturday with the Quaker City Motor Club's roadability run to Cape May, to be followed by the Norristown-Lancaster-Reading endurance run of the Norristown Automobile Club, April 28, the Harrisburg-Philadelphia-Harrisburg endurance run of the Harrisburg Motor Club, May 4-5, and the Wilkes-Barre hill-climb, May 30. These, with the York Automobile Club's endurance run, with another Quaker City Motor Club run to Wildwood, and at least one race meet at Point Breeze, will offer more than sufficient motor pabulum for even the most exacting.

Next Saturday's event for the Hotel Cape May cup already boasts 22 entries, with several more days to hear from. The start will be made after midday, with the finish less than five hours later, the 92 miles of fairly good roads offering no obstacle to the average car unless the weather be decidedly wet.

The Wilkes-Barre hill-climb is becoming as much of an annual fixture for the Quakers as for the Diamond City enthusiasts. Coming on Memorial Day, which falls on Saturday, there will be a week's end hegira of local automobilists to the Luzerne capital to take a hack at the plunder which the Wilkes-Barreans usually hang up to attract them. Arrangements are already afoot for a three-day run to and from the "American blue ribbon hill-climb," and probably the Quaker City Motor Club will call a run, as was done last year.

### NEW PRESIDENT FOR ROCHESTER CLUB.

ROCHESTER, April 6.—In the annual meeting and election of officers of the Rochester Automobile Club, President Harry S. Woodworth retired in favor of Harry G. Strong, and in a farewell speech congratulated the members on the progress made during the year. The new officers are: President, H. G. Strong; vice-president, William C. Barry; secretary, Bert Van Tuyle; treasurer, Rudolph Schmidt. The new board of governors includes James E. Gleason, W. W. Hibbard, John E. Morey, F. E. Mason, Richard T. Ford, George E. Gordon, John S. Bingeman, A. F. Crittenden and Harry S. Woodworth. Until this election Mr. Van Tuyle has filled the office of treasurer and secretary.

In presenting his annual report Secretary Van Tuyle said that the past year showed a net gain of 75 members. At the last annual meeting the number of members in good standing was 335 and the club now musters 410. The stealing of cars has also been stopped, thanks to the action of the club and the co-operation of the police. This year it is proposed to have an additional safeguard in the shape of a filing system, whereby the club office will always have at hand a complete description of the cars owned by members.

The annual banquet of the club will be held Monday, April 13, at the Genesee Valley Club.

### AUGUSTA, GA., CLUBMEN MEAN BUSINESS.

AUGUSTA, GA., April 6.—At a meeting of representative owners, held last Tuesday night at the Chamber of Commerce, steps were taken to thoroughly reorganize the Automobile Association of Augusta to insure great activity in the future. New officers were chosen as follows: President, C. B. Garrett; first vice-president, F. B. Pope; second vice-president, J. H. Davidson; secretary, Dr. Eugene Murphy; treasurer, C. D. Carr.

The club has aims other than mere social intercourse. Plans were discussed for the enrollment of the 110 owners of cars in the city, and for the adoption of speed and other regulations for the mutual protection of the members and the general public. The club will become a member of the Georgia State Automobile Association of the A. A. A., which shortly will be organized.

### DEAD HORSE HILL CLIMB PROBABLY JUNE 6.

WORCESTER, MASS., April 6.—The governors of the Worcester Automobile Club lost no time in calling a special meeting of the board in the clubrooms, upon receipt of word that the bill introduced by a club member and fathered for two years by the club, allowing the mayor and the board of aldermen of cities and the selectmen of towns in Massachusetts to issue permits to hold automobile hill-climbing contests, had passed the legislature. As a result of the meeting, it is announced that the famous Dead Horse Hill contest would be revived probably June 6. This committee was appointed to confer with the mayor and board of aldermen of Worcester and the selectmen of the town of Leicester in regard to the date: John S. Harrington, George Stowe, J. P. Coghlin, D. F. Gay, and F. E. Frost. Both bodies will have to be seen, as the Dead Horse hill course lies partly in Leicester and partly in Worcester.

The passage of the bill is a great victory for the Worcester club, and entailed no little work, in view of the fact that it legalizes speed contests on the fine State highways of Massachusetts, and during the holding of such contests bars the general public off the course, unless it sees fit to pay the admission price charged by the management of such a contest. The committee further announced that it had decided to bar from competition in the mile-long climb all specially constructed speed cars and freak cars. The climb this year—and, probably, in years to come—will be a competition for stock cars only.

### DETROIT CLUB HAS OUTGROWN ITS HOME.

DETROIT, MICH., April 6.—The first warm days of Spring have brought the motorists out in full force, and many runs have already been made to the home of the Automobile Club of Detroit, at Pine Lake, twenty miles distant from the city. The clubhouse will not be opened for the season for some time yet, although plans are being perfected for the housewarming, which will mark the official advent of another season.

The only thing worrying the members now is the question of accommodations. Last year the commodious clubhouse had its capacity tested almost daily, and since that time the membership of the club has increased materially. When the home at Pine Lake was secured it was thought that all future trouble in the way of accommodations had been disposed of, but so firm a hold has motoring taken on Detroiters, and so popular is the club, that at the present rate it will soon be necessary to limit the membership or seek larger quarters.

### PEORIANS DINE AND PLAN FOR TOURS.

PEORIA, ILL., April 6.—The Glide Automobile Club, of Peoria, which is an outgrowth of the old Peoria Automobile Club, held its first annual banquet at the Creve Coeur Club last Monday evening. There were some forty members present and guests from out of the city. A most enthusiastic time was had and a number of plans were outlined for runs and tours during the coming season. The club is collecting information regarding routes and road maps covering Illinois territory.

### CHICAGOANS GO THROUGH "WILDEST CUBA."

CHICAGO, April 7.—Members and guests of the Chicago Automobile Club had a rare treat to-night in an illustrated lecture, "Through Wildest Cuba," setting forth the adventures encountered last winter by S. D. Walden, Ralph Estep and other Detroiters of Packard proclivities in a tour through the island. The lantern slides were all from negatives made by a member of the party that made the trip, and showed, in a striking manner, some of the difficulties met with in touring the island.

## RAPID GROWTH OF AUTOMOBILING IN SOUTH

By F. S. SLY, TRAVELING CORRESPONDENT OF THE AUTOMOBILE.

CHARLESTON, S. C., March 26.—Owing to its location, this city is a good field for both automobiling and motor boating, and some of the dealers handle both marine motors and automobiles, though the latter is their chief standby. There are now about 125 cars in use here and, as some of the autoists are enthusiastic, there has been some talk of organizing a club in the near future, but as yet nothing definite has been done.

C. V. Boykin, a resident inventor, has perfected a very simple little device to enable the driver to always start the motor from the seat on the spark. He has had it in constant use on a Mitchell four-cylinder car here since last July and it has proved very satisfactory in service. Patents were applied for some time ago and will be issued shortly. The inventor does not expect to manufacture the device but is desirous of selling the right to make it on royalty.

The prospects for selling a number of low-priced cars here are excellent. Roads in this part of the State are sandy, in contrast with the heavy clay soil to be found a little further north, and light, low-powered cars seem to fare much better on these sand roads than do much more powerful cars, owing to their weight. The cars represented here are the Premier, Reo, Rapid, and Manhattan, handled by the Charleston Motor Company; the Cadillac and Buick, represented by the Army Cycle Manufacturing Company; and the Ford, Maxwell and Mitchell, which are sold by the Automobile & Marine Motor Company. These three firms all maintain good-sized garages and repair shops, beside which there is the Automobile Repair Company.

### Atlanta Claims Greatest Number of Autos in South.

ATLANTA, Ga., March 28.—This city is really the greatest automobiling center of the South, as it can boast of between 500 and 600 machines—a number equivalent to those owned in a great many other Southern cities put together. A club was formed about a year ago, but through lack of initiative on the part of its organizers interest in the movement was allowed to lapse and no meetings have been held. The project has recently been taken hold of anew and a reorganization of the existing club is now assured. Much interest is manifested in the annual hill-climb, which is to take place to-day. The course is about a mile long, and the start is made from what is practically a standstill, only 100 feet being allowed for the driver to get into high-gear before crossing the line.

The roads around Atlanta are fairly good in dry weather, though most of the cars in use here do not go far outside the city at any time, driving being confined to comparatively short runs. This city's importance as a Southern center of automobiling is reflected in the number of agencies and garages there are here, as well as their prosperous condition. The Packard and Pope-Hartford are represented by F. C. Steinhauer, while the Peerless and Buick are handled by H. C. Nesbit, and the Ford interests are taken care of by the Ford Auto Agency, in Houston street, which maintains a special garage for Ford cars. The Field Auto Company, and the Southern Auto & Equipment Company, the Columbia garage, and F. C. Steinhauer are the principal depots that take care of and repair cars.

### Montgomery Believes in the Building of Good Roads.

MONTGOMERY, ALA., April 1.—The roads about Montgomery are an exception to the usual run of those found in the South, and that much of this is doubtless due to the influence of the automobile is evident from the fact that the county commissioners have recently been prevailed upon to appropriate an additional \$250,000 for the purpose of extending the improvements to the county line on the roads radiating from the city in each direction. This will make Chatham county one of the best equipped of its kind in the South. The Montgomery Auto-

mobile Club has been responsible, in a measure, for the good work thus accomplished.

The Cadillac, Pope-Toledo and Columbia are handled by the Montgomery Automobile Company, which maintains a good garage, as does also the Mosler-Hagler Electric Company, representing the Thomas and Babcock electric; the Capitol City Garage handles the Franklin, Buick and Pope-Waverley, while the Mitchell and Oldsmobile are represented by the Patterson-Ingalls Motor Car Company.

### Jacksonville for Autoing Despite Scarcity of Roads.

JACKSONVILLE, FLA., April 3.—Considering that Florida is generally reputed to have less available road mileage than almost any one of the Atlantic Coast States, the fact that Jacksonville can boast of no less than 375 cars, affords excellent proof of the manner in which interest in automobiling grows, even under adverse conditions. There is an automobile club here, of which Charles Clark is president, and Herbert Race, secretary, but interest in its affairs has been permitted to lag somewhat. The city streets make excellent driving, but immediately outside there is nothing but loose, shifting sand. In addition to this, practically all of the wagons have the wide tread prevalent throughout the South. This is 60 inches, so that the traveling is made even worse for the 56-inch automobile. Cognizance is now being taken of the fact that the five-foot tread is standard down here, and the Ford Company make their light cars conform to this, when so ordered.

A number of cars are represented here, the Premier and Rambler being handled by R. W. Atkinson; the Cadillac and Buick, by Hutto & Co.; the Reo, Stoddard-Dayton, Atlas and Maxwell, by T. E. Gilbert, and the Ford, by L. C. Oliver, each one of these concerns maintaining a well-equipped garage.

### Birmingham Has About 150 Automobiles.

BIRMINGHAM, ALA., April 6.—There are about 150 automobiles owned in this city, which possesses excellent streets, and the roads in the country are fairly good. Preparations are quite advanced for the betterment of country roads, and it is safe to state that in the near future there will be many miles of first-class highways in this vicinity. As one investigates the South, he is constantly surprised by the widespread growing interest in the matter of roads, and, furthermore, roads are actually being constructed.

The automobile trade is quite well represented in Birmingham. The Automobile Exchange handles the National and Ford, also Baker electrics. C. C. Nixon sells Locomobile and Cadillac, and also conducts a garage. The Southern Garage handles Franklin and Brush cars, and the Birmingham Garage looks after Maxwell, Reo and Stoddard-Dayton.

James J. O'Rourke is about to open a new garage, 50 by 90 feet, two stories high, and will represent the White steamer.

Birmingham has a club whose activities have been somewhat apathetic. Its officers are: President, R. S. Munger; vice-president, J. E. Deadman; secretary-treasurer, Charles Denagre.

### An Automobile Course from Chattanooga to Knoxville.

CHATTANOOGA, TENN., April 6.—According to the Chattanooga News, there is a movement on foot to establish an automobile course from Chattanooga to Knoxville. The plans provide for building a 75-foot automobile drive through the Mission Ridge tunnel, and then to Cleveland, and later to Knoxville. When built, it will be used exclusively by autoists, and no horse-drawn vehicles will be allowed on it. According to the News: "The first cost in the building of such a course would be about all the expense there would be attached to its building, because there would be very little wear and tear on such a drive if horses and vehicles drawn by horses are to be kept off it."

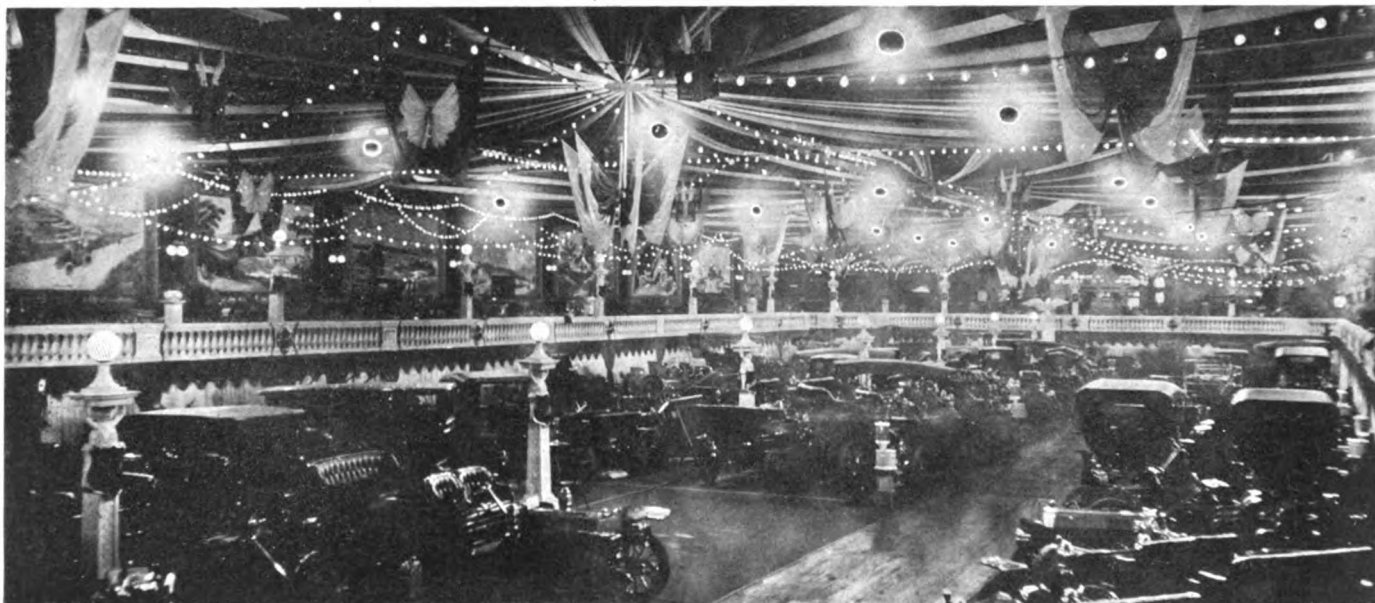

Imposing Display in Duquesne Garden, Pittsburg, Where the Show's the Thing During the Present Week.

### PITTSBURG SHOW BRILLIANT SUCCESS.

PITTSBURG, PA., April 6.—When the Smoky City's 43 automobile dealers, representing no less than 82 different manufacturers of cars, get together and bend their efforts toward the attainment of an object, the result is a foregone conclusion. What they can do was amply illustrated when the doors of the Duquesne garden were thrown open on last Saturday afternoon. Pittsburg is young in the automobile show business, as this is but her second attempt. That the 1907 show was a complete success in every way goes without saying, but the manner in which even that laudable effort has been surpassed in the present event is enough to make manager Thomas L. Cochran and William M. Murray, president of the local trade association, swell with pride. Their contemporaries on the special show committee are W. H. La Fountaine and Earl Kiser.

Prominent among the exhibitors of complete automobiles are two newcomers in the shape of distinctively Pittsburg cars, one being the Belden, of which E. H. Belden is the inventor and which will be manufactured here on a small scale this year, while the other is the six-cylinder roadster being turned out by the Fort Pitt Automobile Company, at New Kensington, a few miles from here. Pittsburg's part in the making of accessories is well represented in the display of the Pittsburg Auto Top & Equipment Company; L. Glasenkamp Sons & Company, manufacturers of limousine bodies; the E. J. Thompson Company, who are also makers of limousine bodies; the Air-Tight Steel Tank Company; the Auto Tire Repair Company; the Auto Specialty Manufacturing Company makers of windshields and Joseph Woodwell & Company, who show a general line of accessories.

The Pittsburg Dealers' Association is issuing an attractive souvenir program giving considerable automobile information, such as routes, maps and the like, and has good reason to congratulate itself on the great success of the show.

#### Automobile Exhibitors.

- Allegheny Automobile Co.—Pierce-Racine, Rapid Truck.
- American Automobile Co.—Pope-Hartford, Pope-Waverley, Pope-Tribune.
- Arlington Motor Car Co.—Jackson, Acme.
- Banker Brothers Co.—Pierce-Arrow, Stevens-Duryea.
- Belden Motor Car Co.—Belden.
- Bellefield Motor Car Co.—Couple Gear Freight Wheel Truck, De Luxe, Pennsylvania.
- Bensen, B. F. & Co.—Rapid Motor Vehicle Truck, Rainier.
- Collins, D. P. & Co.—Lozler, Moon, Studebaker Electric.
- Colonial Automobile Co.—Pope-Toledo, Apperson, Baker Electric.
- Central Automobile Co.—Reo, Premier.
- Diamond Automobile Co.—Buick.
- Fort Pitt Automobile Co.—Locomobile, Oldsmobile.
- Fort Pitt Motor Mfg. Co.—Pittsburg Six.
- Hiland Automobile Co.—Peerless.

- Iams Motor Car Co.—Royal Tourist, Corbin.
- Imperial Motor Car Co.—Cadillac.
- Keystone Automobile Co.—Welch, Stoddard-Dayton, Columbia Electric.
- Liberty Automobile Co.—Mitchell, Wayne, Mora.
- Pittsburg Motor Vehicle Co.—Pittsburg Truck, Babcock Electric.
- Miller Bros.—Model.
- Standard Automobile Co.—Packard, Franklin.
- Schroeder Automobile Co.—Payne-Modern, Cameron.
- Wilkinsburg Automobile Garage.—Elmore.
- Winton Motor Carriage Co.—Winton.
- The White Co.—White Steamer.

#### Accessories Exhibitors.

- |   |  |
|---|--|
| Acetyvone Co.                             | Henry Hubbard.                               |
| Atlantic Refining Co.                     | Iverson Mfg. Co.                             |
| Air Tight Steel Tank Co.                  | Kowalsky, Jno., Motor Works.                 |
| Auto Igniter Co.                          | Kent, A. E.                                  |
| Automobile Specialty Co.                  | Motor Tire Repair & Supply Co.               |
| Barcus, J. C., Farina, III.               | March Metts.                                 |
| Bowser, S. F., Tank Co.                   | Morton, U. F.                                |
| Banker Bros. Co.                          | N. Y. & N. J. Lubricant Co.                  |
| Cleanola Co.                              | Oakmont Motor Boat Co.                       |
| Doubleday-Hill Electric Co.               | Pittsburg Auto Tire & Repair Co.             |
| Davies, J. P. & Co.                       | Pittsburg Hardware & Home Supply Co.         |
| Diamond Cycle Co.                         | Pittsburg Rubber Co., Morgan & Wright Tires. |
| Diamond Tire Co.                          | Robbins Electric Co.                         |
| Eyler & Henry.                            | Union Electric Co.                           |
| Echo Horn Co.                             | Saiman, John A., & Co.                       |
| Firestone Tire Co.                        | Sprague Umbrella Co.                         |
| Fiska Rubber Co.                          | Standard Automobile Co.                      |
| Gabriel Horn Mfg. Co.                     | Sanford, Earl L.                             |
| Goodrich, B. F. Co.                       | Thompson, E. J., & Co.                       |
| Goodyear Rubber Tire Co.                  | Woodwell, Jos. Co.                           |
| Gibney, Jas. L. & Co., Continental Tires. | Warner Instrument Co.                        |
| Hartford Suspension Co.                   | Whitmer & Rung.                              |
| Hartford Rubber Works Co.                 |  |
| Half-Nelson Tire Co., Minneapolis, Minn.  |  |

### MONTREAL SHOW IN SUCCESSFUL PROGRESS.

MONTREAL, QUE., April 6.—Montreal's third annual Automobile and Sportsman's Show opened in the Arena Saturday night. All the spaces are occupied, and several of them overoccupied. It is, of course, too early to form any estimate of the amount of business, but quite a number of out-of-town buyers are in attendance and others have intimated by letter or otherwise that they will be on hand. The exhibitors are quite optimistic as regards the week's outlook. The marine displays are a notable feature of the show.

The Automobile Club of Canada, under whose auspices the show is being held, are to be congratulated in having the joint cooperation of such an able show manager as R. M. Jaffray, who is assisted by Dai Lewis, of Buffalo. Duncan McDonald, the president of the club, introduced Mayor Payette of Montreal, who spoke briefly, and then the show was officially open. The decorations are those used at the Sportsman's show in Buffalo, and the general consensus of opinion is that nothing to equal it has ever been seen here before.





Vol. XVIII

Thursday, April 9, 1908

No. 15

THE CLASS JOURNAL COMPANY

Flatiron Building, Madison Square  
New York City

H. M. SWETLAND, President

EDITORIAL DEPARTMENT

A. G. BATCHELDER, Managing Editor

R. F. KELSEY, Associate Editor C. B. HAYWARD, Engineering Editor

W. F. BRADLEY

BUSINESS DEPARTMENT

A. B. SWETLAND, Business Manager

LOUIS R. SMITH

FRANK B. BARNETT

W. I. RALPH, 1035 Old South Building, Boston, Mass.

C. H. GURNETT, H. E. WESTERDALE, 1200 Michigan Ave., Chicago, Ill.

Cable Address - - - - - Autoland, New York  
Long Distance Telephone - - - - - 300 Gramercy, New York

SUBSCRIPTION RATES:

United States and Mexico - - - - - One Year, \$3.00  
Other Countries in Postal Union, including Canada - - - - - One Year, 5.00  
To Subscribers—Do not send money by ordinary mail. Remit by Draft,  
Post-Office or Express Money Order, or Register your letter.

FOREIGN SUBSCRIPTION AGENTS:

ENGLAND:—Illiffe & Sons, Limited, 29 Tudor Street, London, E. C.  
FRANCE:—Boyveau & Chevillet, 22 Rue de la Banque, Paris.  
GERMANY:—A. Seydel Mohrenstrasse 9, Berlin.

Entered at New York, N. Y., as second-class matter.  
The Automobile is a consolidation of The Automobile (monthly) and the Motor  
Review (weekly), May, 1902, Dealer and Repairman (monthly), October, 1903,  
and the Automobile Magazine (monthly), July, 1907.

Copies printed in 1905	- - - - -	730,000
" " in 1906	- - - - -	791,000
" " in 1907	- - - - -	888,900

A SANE LAW GOVERNING AUTOMOBILING.

No longer the luxury of the few, but now the pleasurable and business necessity of the many, it is a natural sequence that the goings and comings of the automobile should be regulated by common-sense law, preserving the rights of other users of the road and establishing conditions to meet the requirements of the new method of transportation, destined, for economical and time-saving reasons, ultimately to replace vehicles.

Here is the kernel of the proposed New York State law—sponsored in the Senate by such an astute lawmaker as Armstrong and introduced in the Assembly by the experienced Merritt—and it refers to the much discussed miles-per-hour:

**Speed Permitted.**—No person shall operate a motor vehicle on the public highways of this State at a rate of speed greater than is reasonable and proper, having regard to the width, condition, and use of the highway at the time, and the general and usual rules of the road, or so as to endanger property, or the life or limb of any person.

Connecticut has successfully abolished all of the minor speeds up to 25 miles an hour, and now the Empire State appears willing to return actually to first principles—“having regard to the width, condition, and use of the highway at the time and the general and usual rules of the road,” etc.—and the changed attitude of the public seems to harmonize with this most sensible solution of the situation. “Trapping” for excess of eight miles per hour would no longer be possible; there would be no

enforcement of the “law” for purposes of revenue; tourists would not be mulcted for their day of “pleasure.”

But the inconsiderate autoist, who, though in a meagre minority, has brought trouble in plenty to the big majority, will find his pathway beset with difficulties in the way of surer identification, heavier punishment, and, finally, banishment from the highway if he does not curb his reckless abuse of the motor-driven vehicle.

Then, recognizing that he may use the road more frequently than the horse-drawn vehicle, the autoist has accepted the situation as he finds it at present and has willingly agreed to an annual registration fee at increased rates—provided that fee is expended in the maintenance of the roads over which he drives his automobile in the pursuit of both business and pleasure. But the fee is also designated as a tax, and the automobile will no longer be taxable as personal property.

While the law would not be exactly as the autoist would like to have it in every particular, it is by all odds the most progressive statute that has ever been proposed. As President Quayle of the New York State Automobile Association puts it: “It is a long step toward the day when motor vehicle laws will be as dead letters as are the bicycle laws passed fifteen years ago and still on the books.” And Armstrong was a vital factor in getting some excellent bicycle legislation. It seems perfectly logical that he should lend aid in securing the just rights of the automobile, as he did in obtaining equitable laws for the once great but now lowly bicycle.



AUTO SELLING PROSPECTS EXTREMELY GOOD.

That the unseasonable weather was responsible in large measure for much of the financial trouble that beset automobile dealers and makers last summer, long before what has since come to be called the “late depression” set in, is that much more cause for congratulation on the favorable weather conditions that now appear to be in prospect for this year’s selling season. The prospective purchaser of an automobile is not anxious to become the possessor of a machine unless there is some chance of using it and the freezing weather that prevailed last year, practically up to the end of what constitutes the better selling season for autos, namely, June 15, placed an effective damper on stocks in agents’ hands.

An open season such as the present gives a greater stimulus than any other single factor possibly could. Every autoist feels the influence of spring and begins to plan runs and tours. Cars that have been laid up for the winter are taken out, and those that have seen constant service during the cold weather are given an overhauling. The man who has been deferring the purchase of a car feels that he can no longer put it off; new accessories are needed by those who already own cars, and, in a hundred and one different ways, business immediately begins to feel the effect of the stimulus afforded by a favorable season. When it is considered what the industry has passed through—practically unscathed—it may well be said that prospects were never better. Much that was undesirable has been weeded out, and, as a whole, the industry has been benefited far more by the process than it has been harmed. It is quite probable that the present season’s business will show it.

## NEW YORKERS CONTEND FOR COMMON-SENSE LAW

ALBANY, N. Y., April 6.—A bill regulating the use and identification of motor vehicles while operated on the public highways of the State was introduced in the Senate and Assembly on Friday last. Senator W. W. Armstrong, well remembered as the man responsible for the once famous bicycle baggage bill and chairman of the insurance investigations, stands sponsor for the bill in the Senate. In the lower house, Assemblyman Merritt is the introducer. The bill is understood to represent the result of several conferences between the New York State Automobile Association representing the motor users of the State, and the prominent members of the Legislature, and will undoubtedly become a law. It will take the place of the present Motor Vehicle law passed in 1904. It follows quite closely the so-called Uniform Motor Vehicle bill proposed by the American Automobile Association and now being considered by the legislators of other States, and will take effect July 1, 1908. Commenting upon the measure, President O. A. Quayle, of the New York State Automobile Association, says:

"The bill makes several notable changes in the present statute. To meet the prevailing view that motor vehicles seriously injure the improved highways and should, therefore, contribute a considerable sum toward the maintenance of such highways, the bill substitutes for the present small registration fee an annual registration tax graded upward from \$5 for small vehicles, and dependent upon the weight of the vehicle. This, it is estimated, will result in a revenue which, under the terms of the bill, must be used in the maintenance of the improved roads of the State, amounting to upwards of \$400,000. The registration tax includes the furnishing by the State without cost of the two number placards which the new bill requires every vehicle to carry.

"Recognizing that this fee is a tax, the bill exempts all motor vehicles from taxation as personal property. Vehicles used solely for commercial purposes will be registered at half the fees required of the owners of pleasure vehicles, in no event more than \$10, and will not be exempted from ordinary taxation.

"The bill also includes several clauses making far easier identification; thus it requires new numbers annually, the number plates to be of different color each year. More, it requires that these numbers be displayed on both the front and rear of the vehicle; that they be fixed rigidly to the vehicle so as not to swing, and that the rear number be illuminated at night. Still further, and perhaps more important, the display of any number on a motor vehicle other than that issued by New York is prohibited.

"As a means to the detection of chronic offenders, the Secretary of State is required to furnish each county clerk with a list of registered vehicles and registered chauffeurs, and provision is also made for the entry on these lists of the records

of violations of the new speed provisions of the proposed law.

"It being thought that the time is come when the common law rule applicable to the speed of horse-drawn vehicles can be applied to motor vehicles, the arbitrary limit of miles per hour is eliminated and permissive speed is made dependent solely upon the width, condition and use of the highway at the time, and the general and usual rules of the road. Conversely, it has been thought proper to make the penalties for the violation of the speed provisions of the law much more severe and to give a wide discretion in the matter of punishment to magistrates charged with the enforcement of the law. Hence, should the bill become a law, it will hereafter be possible for a magistrate to penalize excessive speeding by a fine of not more than \$250 for a first offense and by a fine not exceeding \$500 for a second offense, or imprisonment not exceeding six months, or both. In no other way has it been thought possible to enforce the common law rule as to permissive speed as above stated. Nor is it believed that the extreme penalty will ever be asserted against any but old offenders and those who by their conduct on the streets and public highways bring motorists generally into dispute.

"The bill takes from local authorities all power to regulate the use of or to tax motor vehicles. The bill also provides that non-skidding devices may be used only when the highways are wet, slippery or covered with ice and snow, and contains the usual provisions exempting manufacturers and dealers from annual registration. There are also provisions requiring lamps, horns, brakes, and the like, and provisions compelling motorists to stop on signal, and exempting non-residents of the State from registration providing they have registered their vehicles under similar laws in their own States and that they display their State numbers when operating such vehicles in this State.

"It is thought that this bill, when passed, will mark the beginning of a new era in the treatment of motor users by government, and that it is a long step toward the day when motor vehicle laws will be as dead letters as are the bicycle laws passed fifteen years ago and still on the books.

"While its penalties will at first blush seem severe, the placing of the motor vehicle on a parity with all other vehicles on the highway and the removal of all arbitrary miles per hour restrictions is the high-water mark in motor vehicle legislation thus far. On the other hand the autoists of New York, thoroughly organized and militant, and thus able to make their views felt, are the first of the organized motorists of the world to formally recognize that until highways can be constructed that will resist the suction and wear of these vehicles and their rubber tires, government has the right to ask a toll or tax from such vehicle owners, which can be used in repairing the damage thus done."

## VANDERBILT CUP RULES SET NEW WEIGHT LIMITS

A WEIGHT limit, which will bring all candidate cars within the present international restrictions in that particular and at the same time serve as a comprehensive standard of eligibility, was adopted by the Racing Board at its meeting, April 2, at A. A. A. headquarters, to discuss, determine and promulgate rules for the Vanderbilt Cup race for 1908.

This weight was set at a minimum of 900 kilograms or 1,983.6 pounds, and at maximum of 1,200 kilograms or 2,644.8 pounds, the previous sole limit having been 1,000 kilograms or 2,204 pounds. The minimum limit is that set for the next Grand Prix contest, in which there is no maximum weight limit, the cars being restricted solely to piston displacement.

Other rules of importance governing the next race for the

Vanderbilt Cup provide that 10 cars may represent any one country; that the entry fee for each car shall be \$1,000; that entries shall close on September 1, and that entrants after that date up to October 1, the date of the final closing of entries, shall pay double entry fees.

The date and route of the race will be announced by the Cup Commission not later than July 1. Already the nominations of two Locomobiles, two Thomas Flyers, two Appersons, a Darracq, and a Renault are practically assured.

The Savannahians, encouraged by the success of their stock car races, are hustling hard to comply with any requirement that may be made as to a longer course and assurances of their ability to accommodate the visiting throng. Missourians have not given

up hope that the choice of the course may fall upon St. Louis. A course in Connecticut has also put forth tentative claims to consideration.

The racing rules submitted by the special committee, made up of Jefferson deMont Thompson, A. L. Riker, S. A. Miles and Alfred Reeves, were considered and slightly amended. They will be promulgated later.

Frank C. Battey, president of the Savannah Automobile Club, was appointed a member of the Racing Board by Chairman Thompson. A resolution was unanimously adopted extending a vote of thanks to President Frank C. Battey and officers of the Savannah Automobile Club, Mayor George W. Tiedeman, Major

William B. Stephens, and Captain R. J. Davant, in command of the military forces patrolling the course, Captain W. G. Austin, chief of police of the city of Savannah, the trade and civic bodies, Governor Hoke Smith, General Clifford L. Anderson, and other State officials, for their splendid cooperation and support in the successful conduct of the automobile races.

The racing Board members in attendance at the meeting were Jefferson deMont Thompson, chairman; Frank G. Webb, M. Rossiter Worthington, Harry W. Knights, A. G. Batchelder, Alfred Reeves, A. L. Riker and Frederick H. Elliott, secretary. Telephonic communication was had with W. K. Vanderbilt, Jr., concerning cup-race matters.

## CHAIRMAN THOMPSON OFFERS CUP FOR STOCK CAR EVENT

THERE was a meeting Tuesday morning last in New York City, at the offices of the American Automobile Association, 437 Fifth avenue, of the Central Conference committee, representative of the American Automobile Association, the National Association of Automobile Manufacturers, and the American Motor Car Manufacturers' Association, at which the following representatives were present:

Representing the A. A. A.—President Wm. H. Hotchkiss; Chairman Thompson, of the Racing board; Chairman Hooper, of the Good Roads board; Chairman Hower, of the Touring board; F. H. Elliott, secretary; L. H. Speare, first vice-president; O. A. Quayle, president New York State Automobile Association.

Representing the National Association of Automobile Manufacturers.—S. D. Waldon, Windsor T. White.

Representing the American Motor Car Manufacturers' Association.—Alfred Reeves, R. M. Owen, Harry Fosdick.

Numerous matters of common interest to such bodies were discussed, among them the following:

**Touring.**—Chairman Hower of the Touring board of the American Automobile Association outlined his plans in connection with the tour and asked for suggestions from the representatives present in regard to the fifth annual reliability touring contest for the year 1908, and received several suggestions which will be incorporated in the rules.

**Racing.**—The racing season being about to open, Chairman Thompson of the Racing board asked for suggestions in connection with the miscellaneous races on circular tracks, and also in connection with the Vanderbilt Cup race. He announced that the Cup race would certainly be held, and that negotiations for a course in the States of Missouri, Georgia and Connecticut were already well

under way. He called attention to the success of the recent Savannah stock touring car races. The representatives of the manufacturers present suggested that there should be but one contest of the latter kind each year, and that it should be international in its character.

This view met with the approval of all of the representatives present, whereupon Chairman Thompson announced that if the manufacturers would support such an international contest, he would be pleased to give to the American Automobile Association, as the national governing body, a cup valued at \$3,000, to be known as the Jefferson DeMont Thompson Cup, similar to the Glidden and Vanderbilt trophies, which might be competed for solely by stock cars in one great annual event. His offer was enthusiastically approved, and the representatives of the manufacturing bodies stated that they would present the matter to their associations at the first possible opportunity. It is likely, therefore, that hereafter there will be one great classic event for stock touring cars in this country.

**Buffalo Convention.**—The proposed convention of the American Automobile Association, to be held at Buffalo coincident with the beginning of the fifth annual tour, was also considered, Chairman Hooper of the Good Roads board being present. It was the opinion of the various representatives that good roads should be the keynote of such convention, and that, if possible, other organizations interested in the subject be asked to co-operate.

**Sanctions.**—Numerous applications which are being made for sanctions for endurance contests and hill climbs were brought to the attention of the Conference committee, and the representatives of the manufacturers' associations assured the A. A. A. that it would stand back of such association in granting or withholding sanctions for such contests as well as any similar action as to races on circular tracks.

**New York Bill Approved.**—The pending bill for a new motor vehicle law in the State of New York was also brought up for consideration and discussed.

**Other Conferences.**—The conference is doubtless the first of several which will be held during the summer season, and illustrates the close relationship which exists between the representative body of motor users in this country, viz.: the American Automobile Association and the representative bodies of automobile manufacturers, viz.: the National Association of Automobile Manufacturers and the American Motor Car Manufacturers' Association.

## PRESIDENT BATTEY PRESENTS SAVANNAH'S PROPOSITION

THE monthly meeting of the executive committee of the American Automobile Association, held Tuesday afternoon at the national headquarters, No. 437 Fifth avenue, developed the fact that no report has yet come from the Judiciary committee of the House of Representatives concerning the Federal Registration bill. President William H. Hotchkiss stated that, despite a news dispatch printed with a Washington date, he was positively informed that the committee had yet to reach a decision on the matter.

The Kentucky State Automobile Association was admitted to membership, now possessing the requisite three clubs.

Chairman F. B. Hower of the Touring board reported the rules for the annual tour, which were adopted without discussion.

Chairman J. D. Thompson of the Racing board presented the revised racing rules, which, with slight modifications, were adopted.

The Technical board was authorized to draft rules for technical contests and reliability runs and tours, and asked to report at the May meeting of the executive committee.

Mr. Battey thoroughly presented the claims of Savannah as a place for the holding of the Vanderbilt Cup race, read a letter from Governor Hoke Smith guaranteeing sufficient troops for the guarding of the course, and said the Georgia city would provide comfortably for all who come to see the race. Since the

matter is one for decision by the Vanderbilt Cup Commission, Savannah's application was referred to that body, which is practically the Racing Board of the A. A. A.

S. D. Waldon, representing the N. A. A. M., and Alfred Reeves, representing the A. M. C. M. A., were announced as being added to the executive committee for the Buffalo convention.

Present were: President William H. Hotchkiss, O. A. Quayle, Jefferson DeMont Thompson, F. B. Hower, A. G. Batchelder, of the New York State Automobile Association; L. R. Speare, Massachusetts State Automobile Association; G. E. Farrington, Associated Automobile Clubs of New Jersey; Windsor T. White, Ohio State Automobile Association; Robert P. Hooper, Paul C. Wolff, Pennsylvania Motor Federation; F. C. Battey, Savannah (Ga.) Automobile Club; Secretary F. H. Elliott.

### CLEVELAND'S CLIMB TO BE HELD JUNE 13.

CLEVELAND, O., April 7.—The date for the annual Cleveland hill climb, originally announced as May 30, has been changed to June 13, in order that there may be no conflict with other events of a like character in other cities on the same date.

The annual meeting of the Ohio State Automobile Association has been set for June 13, the date of the hill climb.



### PEOPLE WHOSE SAY-SO IS WORTH WHILE.

**Roy D. Chapin, Thomas Detroit Motor Car Co., Detroit, Mich.:** "On my return from my trip to the Pacific coast I found conditions at the factory most satisfactory. They are working day and night shifts and on Sunday too though, perhaps, I ought not to let that cat out of the bag. We have produced more cars to date than last season and have led our 1907 production every month except February and March. Sales though, were 25 ahead of March of last year. I always watch the spare part department demands with interest, for its reports always show the weak spots in a car. There seems to be no demand yet for parts for our 1908 car, so I infer it is standing up all right. In fact, I think that this year in the Thomas Detroit we have a mighty well balanced car."

**H. O. Smith, Premier Motor Car Co., Indianapolis, Ind.:** "I am glad to see that the A. A. A. has decided to officially call this year's tour a reliability contest. I have always been opposed to the name of tour, as it makes the event appear more like a joy ride. The object of the event is to demonstrate the reliability and staying qualities of the cars entered, rather than an affair for a good time, as the word tour implies. The contest for the Glidden trophy as conducted by the A. A. A. has accomplished wonders for the industry as it has shown the public that the American-built car is capable of withstanding the most severe tests and can perform the exacting duties expected of it over all kinds of roads and under trying circumstances."

**E. H. Parkhurst, Peerless Motor Car Co., Cleveland, O.:** "In my opinion, the talk of depression in the automobile business is not borne out by facts. In comparison with other industries near Cleveland, I find we have maintained a larger proportion of our full factory force at work than in any other industry of similar size. What depression there has been is incidental to general business depression. In spite of all the talk, our deliveries for March were greater this year than last."

**Benjamin Briscoe, Maxwell-Briscoe Motor Co., Tarrytown, N. Y.:** "Every Spring one hears the question asked, 'Of what use is automobile racing, what good purpose do hill-climbing contests serve, of what practical value are records made in economy, reliability, sealed bonnet, and other stunts?' Participation in these contests is expensive; but I believe they are worth all they cost. Of course, if the maker could sell his product, unsight-and-unseen, have the money he expends in advertising in various forms, eliminate the agent and realize a lot of other weird dreams, it would be fine—for the maker. But it has been ordained that nothing may be had without effort or cost, and to this the automobile buying public has added the further condition, 'You'll have to show me.' Contests do show them."

**W. H. Van Dervoort, Moline Automobile Co., Moline, Ill.:** "New Yorkers live too near Wall Street. They ought to take a trip West, get a breath of fresh air, and throw off the scare. Why, out in Moline we heard about a 'panic,' but until I saw the blanched faces here I didn't know such a strong term was necessary to express the conditions. Lately the banks have loosened up for all we needed, so we suppose the little unpleasantness had passed and been forgotten. But you don't seem to know the war is over yet."

### DETROIT'S BOARD OF COMMERCE IMPRESSED.

DETROIT, April 6.—One afternoon last week the Detroit board of commerce was impressed with the magnitude of the automobile industry. The board had decided to make a tour of the many large factories in Detroit, and began with a visit to the Packard plant. The party was carried from the Board of Commerce Building to the Packard factory in a dozen Packard cars, and then made the tour of the different departments of the factory under the guidance of Sales Manager Waldon, and with other Packard executives to explain the why and wherefore of

motor car construction. The general opinion was expressed by Secretary Ritchie, as follows:

"When we laid out Detroit's Boulevard, we had no idea that any factory with eleven acres of floor space would be built on it. Nor did we know until to-day, that such a thing had been accomplished. Of course, it is natural that a manufacturing company should choose such an advantageous site as the junction of the Boulevard and Belt Line Railway. And we are glad that this location has the country's largest automobile factory, in beautiful modern buildings, instead of the clutter of shanties which generally characterize railway crossings."

Even those of the board who had barely a speaking acquaintance with things mechanical were visibly impressed by the fact that hundreds of diversified lines of work, employing high-grade machinery and skilled labor from nearly all branches of industry, had been organized into a smoothly running system for just the one purpose of manufacturing Packard cars.

### POWERFUL RACERS FOR MONACO BOAT MEET.

PARIS, April 1.—Paris having sent away its annual load of motor boats for the Monaco exhibition and races, speculation is rife as to the records that may be made by the fast craft. From April 1 to 4, the public exhibition and trials will take place, the competitive races opening on Sunday, April 5, for cruisers only. The real interest centers round the last days of the meet, when the championship of the sea, the mile and kilometer, and 50 kilometer events are held.

Half a dozen boats stand out prominently as possible creators of record speeds, the most popular among them being the *Panhard-Levassor*, a 49-foot boat, built by Tellier of Paris, and engined by Panhard. The power plant consists of four Panhard motors of four cylinders each, grouped in tandem, and operating two propellers. Each cylinder having a bore of 7.2 inches, the rating of 120-horsepower per engine, or 480 for the entire plant, is not exaggerated. In the trial spins on the Seine, before being shipped for the South, the *Panhard-Levassor* attained a speed of 38 miles an hour upstream, and 39 miles with the current, which is certainly remarkably fast going for a preliminary test. In the smaller series, Tellier and Panhard will be represented by the *Rapier III.*, successor in a series of exceptionally fast boats.

Brasier will be represented by the *New Trefle*, owned by the English sportsman, Mr. Thubron, and prepared for the races by Gustave Caillois, after an unsuccessful showing last year. A second Brasier, to sail under the name of the *Grand Trefle*, has its steel hull filled with three powerful Brasier racing motors, rated at 130-horsepower each. Despujols, who built the hull, appears to have erred in not sufficiently protecting the engine from water. In a calm sea the boat should be able to get near to 40 miles per hour, but it is doubtful if she will be able to maintain a high rate of speed in a swell.

Italy will send the *Jeanette*, owned by Vincenzo Florio, and equipped with a couple of 120-horsepower Itala engines. *Fiat-Gallinari* has in her 40-foot hull a couple of six-cylinder engines, developing a total horsepower of 250. The boat is looked upon as one of the most serious rivals of the French fleet.

Great Britain is pinning her faith to the *Wolseley-Siddley*, built by Saunders, one of the most skilled of British boat builders, and engined by the Wolseley firm. Its power plant consists of a couple of eight-cylinder motors, developing 200-horsepower. The engines are placed side by side in the hull, and operate independent propellers. In Southampton waters, the English boat attained a speed of over 30 knots an hour. Her victory is looked upon as certain if the weather is rough. *Scarlet Runner*, which will compete under the Union Jack in the small racer class, is only looked upon as a winner under rough weather conditions.

America will not be represented in the racing classes, W. H. Fauber, well known in the States in connection with the bicycle industry, has promised a new type of boat with aerial propeller, but, according to the latest indications, has not been able to advance the work sufficiently to appear at the Monaco meet.





Roomy Lines of the New Renault Taxicabs.

### LACROIX' NEW RENAULT TAXICAB LINE.

By the way of a nucleus of a new taxicab line just started in New York, Paul Lacroix has secured a 10-14-horsepower Renault of this kind. It will be followed by some 50 others, which are expected to arrive from France before July 1, though within a month it is anticipated by Mr. Lacroix that enough will have come to have 20 cabs in operation. The Renault taxicab in question has two seats upholstered in leather, electric lights, hanging speaking tube, cigarette case, ash receiver, and other fittings, and is equipped with four anti-skid tires. Special attention has been paid to providing easy riding springs. The headquarters of the service will be at the Renault branch, Broadway and Fifty-seventh street, though stations at three prominent restaurants have been arranged for by Mr. Lacroix.

### ANOTHER TAXICAB FROM THE WEST.

One of the latest entrants into the field of taxicab building is the Jackson Automobile Company, Jackson, Mich., and the result of their efforts in this direction is illustrated by the accompanying photograph. This newcomer to the Jackson fold has a 90-inch wheelbase, 30-inch wheels and 3 1-2-inch tires. It is equipped with a 2-cylinder, 16-horsepower, horizontal, 4-cycle, water-cooled motor, and has a planetary change-speed gear, giving two speeds forward and reverse, so arranged that they may be operated by pedals, for convenience in city driving. It is hung on full-elliptic springs in the rear and semi-elliptic front. The car is geared for a speed of 25 miles an hour, and is built to carry four passengers inside. Some of them have already been delivered in New York and Boston, where they are greatly admired. Durability and economy of maintenance have been the chief objects of the designer, and the car claimed to greatly excel in these features.



First of the Horizontal-Engined Taxicabs.

### FIRST "PITTSBURG SIX" ON THE ROAD.

NEW KENSINGTON, PA., April 6.—On the occasion of its test, made recently by the designer, B. G. von Rottweiler, the first "Pittsburg Six," as the new cars being turned out by the Fort Pitt Motor Manufacturing Company are known, showed a speed of 68 miles an hour. Mr. von Rottweiler has been building four-cylinder cars in Europe for a number of years, and until recently would not hear of lengthening the motor by an additional pair of cylinders. Now he is an enthusiastic six-cylinder advocate, and his new creation has exceeded his fondest expectations in the way of power and speed. Foreign lines have been very closely followed, as may be seen from the accompanying photograph of the car, as it has the Mercedes type of radiator, axles and wheels. The motor is capable of delivering 75-horsepower at 1,000 r.p.m., its normal speed being lower than this. The car lists at \$2,100, completely equipped as shown.

At the present writing, Mr. von Rottweiler is working on a special six-cylinder racing car, to have a motor measuring 162 mm. bore by 155 mm. stroke, and to give 160-horsepower, which, he thinks, will be the fastest thing on wheels. When it is completed, he expects to issue a general challenge to all comers for a trial of speed, which should prove interesting.

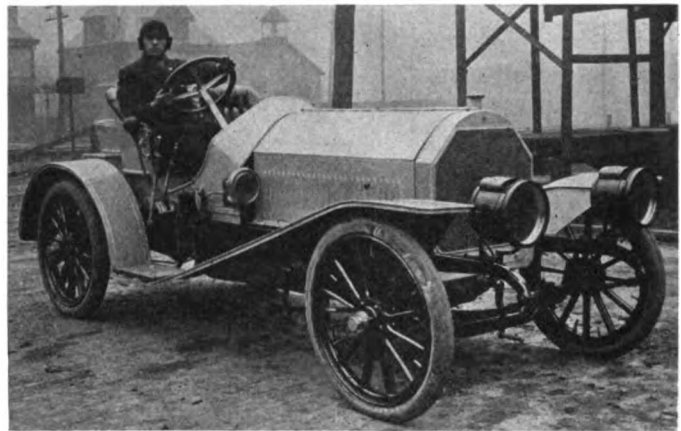

"Pittsburg Six," a Newcomer from the Smoky City.

### FAIRWEATHER CLUB HONORS COL. PARDEE.

NEW YORK CITY, April 6.—High flights of oratory were handed out to a hundred members of the Fairweather Club on April 1, when they gathered at the Cumberland Hotel for their second dinner, with Col. K. C. Pardee, manager of the Maxwell-Briscoé local branch, for the guest of honor. There were a pair of speakers at hand of almost national reputation. The toastmaster, Henry M. Duncan, who has charge of the automobile department of J. B. Brewster & Co., also proved himself capable as an after-dinner talker a bit above the average, and perhaps the best heard at the general run of trade and club banquets. He had pretty poetry to quote galore, and springtime thoughts.

Colonel Pardee, after making his acknowledgments of the compliments paid to him, switched to a historic outline of the birth of the motor microbe, a review of its growth, and a peroration as to its future.

Then came John S. Crosby, a follower of Henry George, who, after touching humorously for a few minutes on the automobile, launched forth in an oration on "The Right of Way," pleading for the right of man to life, liberty, property, contract and land.

Benjamin Briscoe thought that Mr. Crosby was a bit too severe on corporations and suggested that they were, perhaps, after all, but a forerunner of co-operation and mutuality of human endeavor.

Creswell McLaughlin, editor of *The Schoolmaster*, after some funny stories and merry quips, switched to a warning of the dangers besetting the republic, with a glowing tribute to President Roosevelt for his courage in battling against them. "Tom" Moore also talked, with the Briarcliff race for a topic.

## BRIEF ITEMS OF NEWS AND TRADE MISCELLANY

The completed stock and supplies of the Dragon Motor Company have been sold to the Gorson Auto Exchange, 617-619 Arch street, Philadelphia.

Monday at 10 A.M., the first day of New York City's Carnival Week, Percy Williams purchased from Paul Lacroix a 35-45-horsepower touring car. This is the first recorded sale of Carnival Week.

The Matheson Automobile Company, of Wilkes-Barre, Pa., employing 400 hands, resumed operations on April 1 after two months of idleness. Orders have been received for \$400,000 worth of cars and all the old hands were put back to work.

In the issue of THE AUTOMOBILE of March 26, on page 452, H. R. Teele was given as the patentee of the tire case shown. This was an error, as the patentee of the case in question is F. B. Hopewell, of Hopewell Brothers, Cambridge, Mass.

Andrew Carnegie, the well-known ironmaster, has purchased a Studebaker car for his tour through the Scottish Highlands the coming summer. The car is equipped with a low-g geared axle and a strongly reinforced limousine top, for the purpose of carrying heavy baggage and touring equipment.

A new repair shop and garage has been opened at Peoria, Ill., at Madison and Liberty streets, by Phil Stein and Clarence Christ. They will make a specialty of catering to users of the Glide car, which are numerous in its home city. Both members of the firm were formerly connected with the Glide factory.

The Rochester Tire Company, Rochester, N. Y., capitalized at \$20,000, filed its certificate of incorporation last week. The concern will deal in automobiles, and the directors are Percy W. Hodgkinson, Robert B. Cochrane, Emil Broeker, Charles H. Hall, Thomas J. Thurber, Richard P. Martin, and Charles D. Camp.

Complete to the minutest detail, the handsome new salesrooms and garage of the Bergdoll Motor Car Company, at 325-327 North Broad street, Philadelphia, will be thrown open to the public during the present week. "Open house" with all the usual floral, musical and gastronomical trimmings will be in order.

In the recent automobile races held in Havana, Cuba, a Winton Sixteen-Six won the race for runabouts of 25-50-horsepower, defeating one American and four foreign entries. The time was 2:11 3-5, over a 1.7-mile course, with one sharp and very dangerous turn. The second car finished four seconds later, and the last foreign car was 31 seconds behind.

The affairs of the Boyer Motor Car Company, of San Francisco, are being wound up. The company suffered two fires during the past year, and was unable to successfully pull through the recent business depression. The Boyer Company handled the Franklin and Royal lines. Mr. Boyer will continue as a leading selling factor with the new Franklin agency, the Consolidated Motor Car Company.

Wm. P. Miller's Sons, Long Island City, N. Y., manufacturers of Pan-o-lite oils and greases have begun the erection of a new factory and office building on Hancock street, near Webster avenue. The building

will be brick and iron, two stories high, and will give the concern the much needed room it desires to handle its growing business.

The Corbin Motor Vehicle Corporation, of New Britain, Conn., has increased its capital stock from \$200,000 to \$500,000. The increase was made necessary by the expanding demand for its product, which had to be met with increased facilities for production. The company states that the sales of Corbin cars for the first three months of the present year far exceed those for the same period of last year.

### RECENT BUSINESS CHANGES.

The Penn Motor Car Company, agent for the Mitchell car in Philadelphia, removed last week from Broad and Ridge avenue to new and much larger quarters at 138-140 North Broad street.

Owing to the necessity of being located at a better distributing point, the Slama Tire Protector Company has removed its general offices from Humboldt, Neb., to 609 East Fifteenth street, Kansas City, Mo. The factory will remain at Humboldt.

The Continental Caoutchouc Company, which has had its headquarters for a number of years at 43 Warren street, New York City, announces its removal to 1788-1790 Broadway, corner of Fifty-eighth street, the premises formerly occupied by the Baker Electric Company. The Continental people will take immediate possession. General Manager Gilbert reports an increasing demand for Continental tires this season, particularly for the new demountable rim carrying ready-flated tires.

### NEW AGENCIES ESTABLISHED.

The Babcock electric was last week added to the long list of cars represented in Philadelphia. Prescott Adamson, Broad and Spring Garden streets, who handles the Columbia gasoline and electric cars, will look after the interests of the new comer in the Quaker City.

The Consolidated Motor Car Company, 402-406 Golden Gate avenue, San Francisco, has taken the agency for the Franklin and will be exclusive Franklin dealers in that city. The officers of the company are: President and manager, S. G. Chapman; vice-president, J. H. Doust; secretary, Max L. Rosenfeld. Other new Franklin agencies established are with the Brown Brokerage Company of Coffeyville, Kans., which has opened a new modern salesroom and garage, and with W. B. Jernigan, who will open a new salesroom and garage at Pensacola, Fla., and handle the Franklin exclusively.

New agencies for Jewel automobiles have been established by the makers the Forest City Motor Car Company of Mazon, O., as follows: Jewel Automobile Company, 210 Temple Court, Denver, Col.; J. A. Lory, Rock Rapids, Ia.; Wm. Tobin, Decorah, Ia.; L. N. Simon, Goff, Kans.; Henry Humfreville, Waterville, Kans.; Edward C. Hubert, New Orleans; L. E. Gordon, Deer Lodge, Mont.; M. J. Cook, Holland, Mich.; Boyce Carriage Company, 324 Ross avenue, Winnipeg, Canada; O. S. Sagmoen, Cray, North Dakota; M. A. Grant, 1016 Prairie avenue, Houston, Tex.; Herman F. Gerhard, Austin, Tex.; C. H. Dean, 226 South Flores street, San

Antonio, Tex.; Ray-Wortham Company, 609 Throckmorton street, Fort Worth, Tex.; Auto Service & Motor Company, Cheyenne, Wyo.; Coatsville Carriage Company, Coatsville, Pa.

### PERSONAL TRADE MENTION.

Charles B. Shanks, sales manager of the Winton Motor Carriage Company, Cleveland, O., is taking the baths at Mudlavia, the famous Indiana health resort. Major H. L. Kramer, proprietor of Mudlavia, is a Winton enthusiast of long standing.

Leman Greenwald has resigned as superintendent of the Empire State Tire Company of Buffalo, N. Y., to whom he sold one of his inventions, the Greenwald internal protector. Mr. Greenwald will devote his time to perfecting some other inventions in the tire equipment line, a public announcement of which will be made later.

Carl Kaufman, general manager and treasurer of the Motor Car Equipment Company, 55 Warren street, New York City, sailed for Europe on Tuesday, April 7, where he will spend two months getting into touch with the leading manufacturers of automobile equipment and supplies, and place large orders for the new goods on the European market.

Dr. Chas. G. Percival, until the beginning of the present month sales manager and publicity promoter for the Cleveland Motor Car Company, of New York City, will, in the future, be associated with F. Edward Spooner in conducting the automobile department of the A. W. Erickson Advertising Agency, and in the publicity work of Mr. Spooner. Dr. Percival has been identified with the automobile industry since its earliest inception in this country as a publicity expert.

Through the efforts of the E. A. Jenkins Motor Company, R. M. Owen, of R. M. Owen & Company, general sales agents for the Reo and Premier lines, was given an enthusiastic reception on his recent visit to Columbia, South Carolina. He was made the guest of honor at a banquet at which most of the prominent autoists in that vicinity were present. At this banquet a movement was started to improve the road between Columbia and Camden, S. C., and almost \$1,000 was subscribed.

Charles M. Steele, a former Chicago newspaper man, has joined the E. R. Thomas Detroit Company. Mr. Steele will have charge of all publicity for the Thomas Detroit Company and will assist Lee Counselman, the sales manager. Mr. Steele comes from the H. H. Franklin Mfg. Co., of Syracuse, N. Y., where he held the position of advertising manager. Prior to his connection with the Franklin Company he was in charge of the publicity department of the National Cash Register Company. Mr. Steele's work there first brought him to the attention of Hugh Chalmers, formerly general manager of the cash register company and now president of the Thomas Detroit Company.

### BYRON J. CARTER DEAD.

DETROIT, MICH., April 7.—Byron J. Carter, vice-president and general manager of the Motor Car Company of Detroit, and inventor of the friction type of drive applied on the well-known Carter car, succumbed to pneumonia yesterday.

## INFORMATION FOR AUTO USERS

**Rex T-Socket Wrench.**—There is no task so difficult as that of making repairs or adjustments without the aid of the proper tools, and autoists have learned to their cost only too often that tools made for ordinary purposes are not suited to the special needs of the automobile. This is particularly true of the wrenches generally provided, for despite the best efforts of the designer, it is impossible to make every part of the mechanism of a car as accessible as it would have to be in order to permit of reaching it with an ordinary wrench. Many nuts and bolts have to be turned around a corner, and here is just where the value of a special set of wrenches, such as the Rex, comes in. It is being manufactured and marketed by the Rex Wrench Company, Boston, Mass. A Rex wrench outfit consists of a full set of interchangeable steel sockets of special form and a handle to which they may be attached and instantly locked at any desired angle. These sockets are in a series, comprising the standard sizes of nuts. The crossbar in the handle may be firmly set at any position to give the best hold for getting into corners. Screwdriver and spark plug wrench parts are also provided, and may be fastened to the handle in the same way.

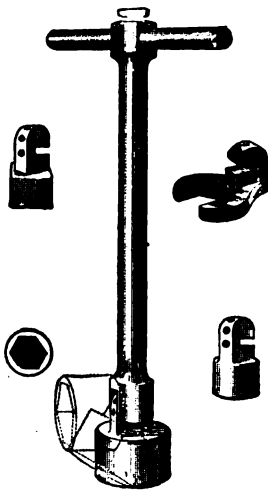

REX WRENCH AND PARTS.

**Automatic Fuel Feed.**—One of the greatest drawbacks of the early steam automobiles was the difficulty encountered in maintaining a constant and uniform fuel feed. To overcome this, F. W. Ofeldt & Sons, Nyack-on-the-Hudson, N. Y., have invented and perfected a device which they term an "Automatic Fuel Feed." Its greatest advantage is that it does away with air pressure for feeding the fuel and saves much laborious pumping that makes running a steamer far from a pleasure at times. It permits of any quantity of fuel being put into the tank, and of the tank being examined at any time to learn how

much it holds, without loss of pressure and the consequent necessity of hand pumping. It gives from 100 to 150 pounds pressure for starting the burner in half a minute or less, by operating a small fuel hand pump

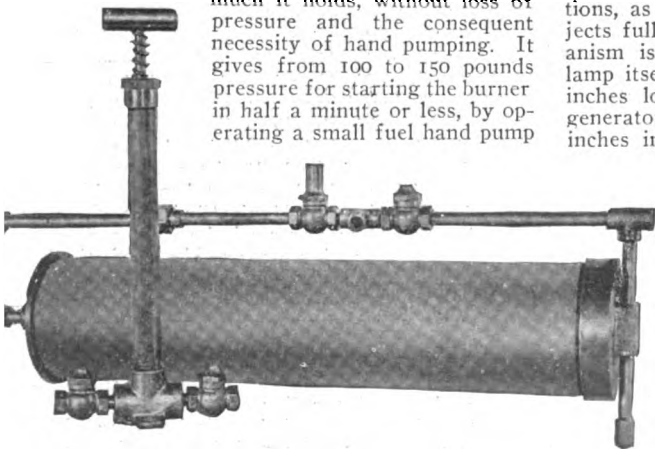

OFELDT AUTOMATIC FUEL FOR STEAM CARS.

with the thumb and forefinger. A perfectly tight fuel line is always possible with it, as any leaks can be seen and repaired, and it makes the steam car the easiest to start, in addition to making it far safer than where a large tank of kerosene or gasoline is constantly carried under a high air-pressure, as in the Ofeldt system, only about three pints of fuel are under pressure at one time in the 18-inch automatic fuel feed.

**Electric Arc Searchlights.**—To supply the demand for a *real* searchlight, i. e., one of the electric arc type, for automobile use, the Richardson Engineering Company, Hartford, Conn., has just brought out the style shown by the accompanying illustration. It is equipped with a Mangin mirror and takes current from a small direct-current generator run by the engine. Unlike previous attempts at this form of lighting direct from the generator, the new Richardson searchlight throws an effective beam at all speeds over a walk, and does not go out as long as the engine continues to run at anything above the rate at which it is

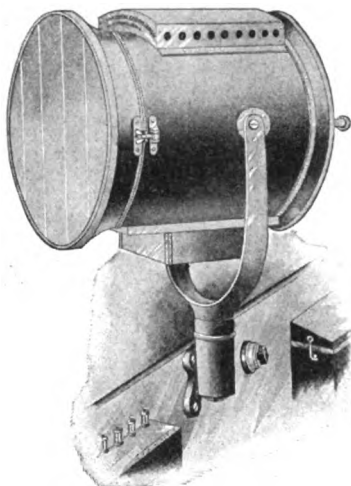

RICHARDSON ELECTRIC SEARCHLIGHT.

merely turning over. Naturally, the light is diminished at low speeds but the makers claim that it is greater than that given by an acetylene lamp, even under such conditions. At normal speed it is capable of lighting up comparatively small objects fully one-fourth mile away. D. A. Richardson has tried one of these searchlights out on his own car and found that the results surpassed his most sanguine expectations, as he was able to pick up large objects fully one-half mile away. The mechanism is strong, simple and durable, the lamp itself measuring 8 inches wide, by 12 inches long by 12 inches high, while the generator necessary to operate it is 7 1-2 inches in diameter and weighs 45 pounds. The dynamo is of the direct-current type, and has been designed especially with a view to this particular service.

**Tray Plate Batteries.**—In adapting accumulator to auto service for ignition, the chief difficulty encountered at the outset was the rough usage to which they were subjected, and which caused the plates to disintegrate, the active material soon piling up on the

bottom of the cell and short-circuiting the different elements. The Tray Plate Battery Company, 5 Frederick street, Binghamton, N. Y., have made a special study of the conditions of automobile ignition service and as a result have brought out a cell particularly designed to give the



TRAY PLATE IGNITION ACCUMULATOR.

maximum life and efficiency under rough usage. They have made a series of practical road tests extending over the past three years, and have found that their batteries will run a four-cylinder touring car as far as 3,400 miles on a single charge. The grids employed are constructed to give a large amount of active material with ample conducting surface for the current, and all materials used are chemically pure. The cells are so made that they may be inverted without spilling any of the acid, thus preventing corrosion of the terminals.



ANOTHER STYLE TRAY PLATE BATTERY.

The makers also guarantee the Tray Plate cells to be non-sulphating, so that they have a long life with a minimum up-keep expense. The accompanying illustrations show two types of complete batteries.

**"Non-Gran" Bronze.**—According to the makers of "Non-Gran" bronze bearing metal, "granulation is the basic cause of all cutting," and one of the greatest advantages of their product is that it is absolutely proof against granulation. It is positively smooth-wearing and works for long periods under constant, heavy service with a minimum of friction. The makers, the American Bronze Company, Berwyn, Pa., have been supplying a number of the most prominent American builders of cars for several years past, and are always ready to answer inquiries concerning the nature of their product as well as its adaptability for special forms of automobile service. Prime lake copper is the basis of the "Non-Gran" bronze bearing metals and everything used in its manufacture is of the highest grade.

# THE AUTOMOBILE

## Next the Race for the Briarcliff Trophy



WITH the carnival successfully disposed of, the Briarcliff Trophy race, which will be run over a 30-mile course in Westchester county during the forenoon hours of next week Friday, monopolizes the attention of the metropolitan automobile world. Dealers and importers and individuals have given the contest support to the extent of 22 entries, equally divided between the domestic and the foreign product. The American end of the contest will be held up by three Stearns, two Loziers, two Simplexes, a Thomas Flyer, an Allen-Kingston, a Hol-Tan Shawmut, and an Apperson. French importers will be represented by two Renaults and a Panhard. Rival Italian teams will be a Bianchi, a pair of Fiats, and a trio of Isottas. Austria will be in evidence with a Maja and Germany with a Benz.

The committee in charge has been lenient in its interpretation of the rules of the race restricting the cars to stock chassis, deciding that cars with Kaiserpreis equipment are eligible, on the theory that the big annual struggle in Germany is intended to be a race for touring cars, and by accepting other entries on the assurance that at least 10 cars of the competing model had been or would be built.

The normal difficulties of the course, arising from numerous sharp turns, narrow stretches, and an absence of macadam surface for nearly one-third of the way, are likely to be considerably magnified by soft and rough going on the dirt road sections due to early spring mud. These obstacles will, it is believed, come pretty near to placing all of the cars on a fairly even footing and leave the outcome largely dependent on the skill of the

pilots. It has been persistently reiterated by its promoters that the contest is intended to be a test of stock chassis under touring conditions rather worse than normal. It looks now as though the conditions alleged to have been aimed at had been secured to an extent a bit beyond the hopes of the management or the expectations of those that made the entries. A fortnight ago there was some talk of the advisability of a postponement to a later date, when a dryer and better prepared course might be expected; but the entrants decided to take all risks, and voted against a postponement. The question of added practice expenses and the original promise of the promoters to furnish the local trade with an event that should stir up spring business a bit earlier than formerly, were also among considerations that influenced the New York tradesmen in their vote against postponement.

Criticisms of the unpreparedness of the course by the entrants and the local press have spurred the committee in charge to greater efforts to eliminate the early spring ruts and mud holes, and not only possible but fair racing conditions are promised by the promoters by the day of the race, and perhaps in time for a little more universal practice with the competing cars than prudence has so far permitted. Much of the preliminary training thus far has been confined to a study of the sharp turns in touring cars. Spring rains have been a delaying factor in this preparation of the course, and difficulties have been added to the work by the general character of the country, which is hilly, and, therefore, subject to miniature streams that seam the surface.





BERNIN.....Renault HILLIARD.....Hol-Tan LYTLE.....Apperson ROBERTS.....Thomas VAUGHAN.....Stearns



STRANG.....Isotta



CEDRINO.....Fiat



POOLE.....Isotta



ROBERTSON.....Panhard



HARDING.....Isotta

Drivers Who Have Won Their Spurs.

The American racing world has been explored for its best drivers, and eighty per cent. of the pilots signed have won fame or are more or less well known as contestants in prominent racing events. The Stearns people have secured a rather formidable trio in Oldfield, Vaughan and Leland. It will be the track champion's first essay at road racing. Vaughan and Leland have both scored successes in track races and hill climbs, but they, too, have not heretofore figured in road events. The Isotta aggregation has picked up a clever trio in Strang, who won the Savannah cup; Poole, who was Tracy's mechanic in his big races, and Harding, who won the 1906 Wilkes-Barre hill climb. Paul Lacroix will pin his faith on Maurice Bernin, who has driven in Vanderbilt contests and at Ormond and won for the Renault 24-hour honors at Morris Park. Herbert Lytle, of Vanderbilt Cup fame, who was a winner at Savannah, will be at the wheel of the Apperson Jackrabbit. Montague Roberts, the Thomas Flyer pilot, has had a lot of varied experiences on the track and road, having driven in Vanderbilt Cup elimination trials, won the 24-hour Brighton Beach race, and piloted the New York-Paris Thomas part way across the continent. Emanuel Cedrino, a Vanderbilt Cup and track driver, will man the Fiat, and Arthur Campbell, another contender in the Long Island classic, an Allen-Kingston. Michener and Mulford, the Lozier pilots, were at Savannah, and have been inveterate contestants in the big 24-hour track races. Bergdoll, who won the stock car race at Ormond in record time, will drive his Benz again, unless he decides to surrender the wheel to Parker, his racing expert. W. M. Hilliard, to whom the Hol-Tan Company has entrusted the Shawmut, is a Boston racing expert, who has driven at Ormond, up Mt. Washington, and on various tracks.

Incidents of the Training Have Been Lively.

Racing camps have been pitched at convenient locations around the course. The Lozier, Simplex and Stearns are at Briarcliff; the Maja and Isotta at White Plains; the Thomas and Hol-Tan at East View; the Panhard at Valhalla; the Apperson and Fiat between Hawthorne and Briarcliff.

The candidates have for the most part prudently confined their preliminary practice to a study of the difficulties of the route in touring cars. So bad has been the roadway in places that drivers have actually taken to the ditches to avoid the bad spots.

The early crop of practice disasters has been already quite large. Two were reported to have occurred on Sunday morning. Joseph Seymour, a member of the Simplex team, in rounding a sharp turn near Mt. Kisco, ran into a stone wall, throwing out Seymour and his three companions, R. C. Watson, another Sim-



OLDFIELD.....Stearns



LELAND.....Stearns



MICHENER.....Stearns



MULFORD.....Stearns



BERGDOLL.....Benz



PARKER.....Fiat



WATSON.....Simplex



MURPHY.....Maja



CAMPBELL.....Allen-Kingston



SEYMOUR.....Simplex



Between Wampus Lake and Armonk, One of the Most Picturesque Stretches on the Varied, Tortuous Yet Picturesque Course.

plex driver, and Phil Fehr and Thomas Corter, mechanics. The front wheels of the car were badly bent.

The same morning David Murphy was putting through its best paces the Maja, entered by Major J. J. Brown, of White Plains, when the car struck a small stone, skidded and was overturned in the ditch. Murphy's arm was badly cut, and the steering rod of the car was broken and its frame bent.

On Saturday, Montague Roberts, while taking a sharp turn in a Thomas Flyer runabout, skidded off the road so sharply that he and his mechanic were thrown out.

The Hol-Tan Company has made an eleventh-hour substitution of a Shawmut for its Hol-Tan. W. M. Hilliard, who will pilot it in the race, drove it down from Boston on Sunday, making the 250 miles over bad roads in 10 hours. The Shawmut is quite a well-known Boston product, having been manufactured by a company at whose head is Elliot C. Lee, former president of the A. A. A. and a prominent banker. Negotiations are in progress for the Hol-Tan Company to add the Shawmut locally to its Hol-Tan line. The Shawmut will be one of the smallest and lowest powered cars in the race, being rated roughly at 40 horsepower, with a piston area of a fraction over 72 cubic inches. Hilliard at once took up his quarters on the course.

The present bad condition of the course, or its probable state on the day of the race, after all promised repairs have been made, not being taken into consideration, the route normally

presents great obstacles to high speed. The curves are practically continuous and sharp turns frequent. In fact, eighteen bad turns to the circuit are admitted by the management. It will be remembered that the sinuosities of the Savannah course, even with the sharp curves well banked, slowed down cars that had shown a 70-mile an hour ability on the straightaways to an average of 50 miles an hour in the race. The Georgia circuit was a race course as compared with the Westchester route. Accordingly, the possible and probable average rate per hour likely to be attained by the Briarcliff candidates becomes a matter for the committee's serious consideration, in view of the fact that the road will be closed against the racing cars at 1 o'clock in the afternoon. The impression prevails that the winner of the Westchester race will be that driver who sets a steady and safe pace and pursues the even tenor of the way without any reference to the perhaps more brash efforts of his competitors.

**Start of Race Will Be at 4:45 A.M.**

With the start set for 4:45 o'clock in the morning, there will be 8 1-4 hours available for the 300-mile run at present scheduled. This will require an average of 36 1-3 miles an hour to complete the race in time. The fastest single laps in practice so far reported were done in about 50 minutes, an average of 36 miles an hour. There is every hope, though, that by the day of the race the course will be so far improved as to admit of a cut of

**DETAILS OF THE CARS THAT WILL COMPETE FOR BRIARCLIFF HONORS.**

No.	CAR	Entrant	Driver	Cyls.	Piston Displacement	H.P.	Ignition	Clutch	Drive	Tires
1.	Hol-Tan-Shawmut	Hol-Tan Co.	W. M. Hilliard	4	72.88	35	Bosch H. T.	Disc.	Shaft.	Continental
2.	Renault	Paul Lacroix	M. G. Bernin	4	86.59035	35-45	Bosch H. T.	Cone	Shaft.	Michelin
3.	Stearns	W. C. & P.	Guy Vaughan	4	90.7286	30-60	Bosch H. T.	Cone	Chain.	Pennsylvania
4.	Stearns	W. C. & P.	Barney Oldfield	4	90.7286	30-60	Bosch H. T.	Cone	Chain.	Pennsylvania
5.	Isotta	Isotta Company	Al. Poole	4	102.88	50	Eisemann H. T.	Disc.	Chain.	Michelin
6.	Fiat	Fiat Company	Emanuel Cedrino	4	96.0336	60	Bosch L. T.	Disc.	Chain.	Continental
7.	Allen-Kingston	W. C. Allen	Arthur Campbell	4	78.54	40-45	Bosch H. T.	Disc.	Chain.	Michelin
8.	Isotta	Isotta Company	H. J. Harding	4	102.88	50	Eisemann H. T.	Disc.	Chain.	Michelin
9.	Isotta	J. H. Tyson	Louis Strang	4	102.88	50	Eisemann H. T.	Disc.	Chain.	Michelin
10.	Stearns	F. B. Stearns	Frank Leland	4	90.72	30-50	Bosch H. T.	Cone	Chain.	Pennsylvania
11.	Simplex	Palmer & Singer	R. C. Watson	4	103.884	50	Bosch H. T.	Disc.	Chain.	Continental
12.	Panhard	Panhard & Levassor	George Robertson	4	103.884	50	Eisemann H. T.	Disc.	Chain.	Continental
13.	Lozler	Lozler Company	Ralph Mulford	4	86.59035	45	Bosch H. T.	Disc.	Shaft.	Diamond
14.	Lozler	Lozler Company	Henry Michener	4	86.59035	45	Bosch H. T.	Disc.	Shaft.	Diamond
15.	Maja	J. J. Brown	D. D. Murphy	4	58.92	35-40	Bosch L. T.	Disc.	Chain.	Continental
16.	Fiat	Fiat Company	E. H. Parker	4	96.0336	60	Bosch L. T.	Disc.	Chain.	Continental
17.	Thomas	Harry S. Houpt	M. Roberts	4	96.034	60	Bosch H. T.	Disc.	Chain.	Diamond
18.	Apperson	S. B. Bowman	Herbert Lytle	4	103.86	50	Bosch H. T.	Con. Band	Chain.	Not decided.
19.	Simplex	Palmer & Singer	Joseph Seymour	4	103.884	50	Bosch H. T.	Disc.	Chain.	Continental
20.	Benz	L. J. Bergdoll	L. J. Bergdoll	4	103	80			Chain.	Diamond
21.	Renault	Paul Lacroix	Julian Bloch	4	86.59035	35-45	Bosch H. T.	Cone	Shaft.	Michelin
22.	Bianchi	Percy Owen, Inc.	Felix Prossen	4	82.48	40	Bosch L. T.	Disc.	Chain.	Michelin



"Prepare to Meet Thy God" is Inscription on Stone.



A Good Stretch of Road Near Echo Lake.



A Bad Stretch of Road Near Valhalla.



A Railroad Crossing in Mount Kisco.

five minutes per lap at top speed going. This would give 40 miles an hour average. Unless the course be improved far beyond expectations, it would seem highly improbable that an average speed of 45 miles an hour will be attained. The cars will have to hustle to finish within the time limit, and there is very likely to be more than one weak brother to get the flag before he has finished his entire course.

**Order in Which They Will Start.**

The drawing for the order of start in the race took place on Tuesday afternoon at the committee's headquarters in the Bryant Park Building. By way of preliminary to the drawing, Robert Lee Morrell, the chairman, outlined a scheme of drawing following the method employed in drawing the positions of the members of the various national teams in the Vanderbilt Cup race, the different makes being given recognition as teams. His idea was that the makes should be separated, to do away with possible team work. This plan would have divided the entrants practically into three divisions.

C. F. Wyckoff, of Wyckoff, Church & Partridge, was on his feet in an instant with a protest, pointing out the fact that this arrangement would insure one Stearns and one Isotta being at the tail end of the procession. At once representatives of other makes were adding their protests and calling for a free-for-all drawing.

The chairman retreated from his position and put the question to vote. The single entries, of course, all liked the Morrell plan, as it would insure them a place in the first fourteen, and the multiple entries just as naturally preferred to take their chances in a general drawing. The Morrell plan was voted down and a free-for-all drawing substituted by a vote of 11 to 8, Mr. La Croix declaring he had no preference and not voting. Bergdoll, the Benz entrant, was absent.

It was subsequently agreed, however, that should two makes be brought together in line the second one should be moved down a place. There was a preliminary drawing for the order of drawing and then came the final drawing, which resulted as follows:

No.	DRIVER	CAR	COUNTRY.
1.	Felix Prossen.....	Bianchi.....	Italy
2.	Emanuel Cedrino.....	Flat.....	Italy
3.	Herbert Lytle.....	Apperson.....	America
4.	Louis Strang.....	Isotta.....	Italy
5.	F. W. Leland.....	Stearns.....	America
6.	E. H. Parker.....	Flat.....	Italy
7.	Harry Michener.....	Lozler.....	America
8.	Guy Vaughan.....	Stearns.....	America
9.	Ralph Mulford.....	Lozler.....	America
10.	D. S. Murphy.....	Maja.....	Austria
11.	Al. Poole.....	Isotta.....	Italy
12.	Montague Roberts.....	Thomas.....	America
13.	Barney Oldfield.....	Stearns.....	America
14.	M. G. Bernin.....	Renault.....	France
15.	George Robertson.....	Panhard.....	France
16.	W. M. Hilliard.....	Hol-Tan-Shawmut.....	America
17.	A. C. Campbell.....	Allen-Kingston.....	America
18.	Julian Bloch.....	Renault.....	France
19.	H. N. Harding.....	Isotta.....	Italy
20.	L. J. Bergdoll.....	Benz.....	Germany
21.	M. J. Seymour.....	Simplex.....	America
22.	William Watson.....	Simplex.....	America

The two Simplex cars having drawn positions together at the end a question arose as to what was to be done. The suggestion that one of them be moved to the head of the line was not received with favor and the pair were with universal consent left in *statu quo* at the tail end.

**Substantial Prizes Hung Up for Drivers.**

With their usual generosity, the tire companies have come forward with substantial rewards for the drivers of cars who finish in the first three places on cars equipped with their tires. The Continental Caoutchouc Company is offering \$650, \$250 and \$100 for the drivers finishing in first, second and third places, respectively, on cars equipped with Continental tires, while the Michelin Tire Company is offering similar



prizes of \$500, \$300 and \$100 for cars equipped with Michelin tires, finishing in the same order. In addition to this, Henry Hess, of the Hess-Bright Manufacturing Company, has deposited a check for \$100 with Chairman Morrell, to be awarded to the driver finishing first with a car equipped with the HB or DWF ball-bearings.

**'WARE ABOUT NEW HAVEN.**

NEW HAVEN, CONN, April 13.—New Haven these days is a good place for visiting autoists to slow up when passing through, owing to an energetic campaign recently instituted by the police against auto speeders. Measured courses and traps have been prepared all over the city and officers in plain clothes are daily detailed to guard them and time all automobiles passing. Several prominent automobilists have been arrested and heavily fined in the police court. The police activity is the result of a number of flagrant cases of over-speeding and accidents, two of which resulted fatally.

**NIAGARA FALLS BOULEVARD.]**

BUFFALO, N. Y., April 13.—Every member of the Automobile Club of Buffalo is working industriously for the plans which mean the construction of a boulevard between Niagara Falls and Buffalo. The necessity for such a boulevard is felt by all automobilists. Secretary D. H. Lewis, of the club, is looking after the project, and there is no let-up in his efforts. The fund started at the last automobile show is being increased by subscriptions. Mr. Lewis says of the plan: "That a boulevard is needed between Buffalo and Niagara Falls is conceded, and it is not beyond the pale of possibility that the agitation will bring results before the year passes into history."

**G & J CO. LOSES SUIT.**

Following upon the adverse decision of the United States Circuit Court last summer in the action brought against the Pennsylvania Rubber Company by the G and J Company, for infringement of its patents on the clincher type of tire, the case was carried to the United States Circuit Court of Appeals for the Third District, which has just handed down a decision affirming in every respect the findings of the lower court. The latter were to the effect that the tire on which the G & J Company claimed the Pennsylvania Rubber Company to be an infringer was not the tire described in its patents, which were the basis of the action, and further that the patents in question described a device which the plaintiffs were not using on their tires, and which, consequently, could not have been infringed.

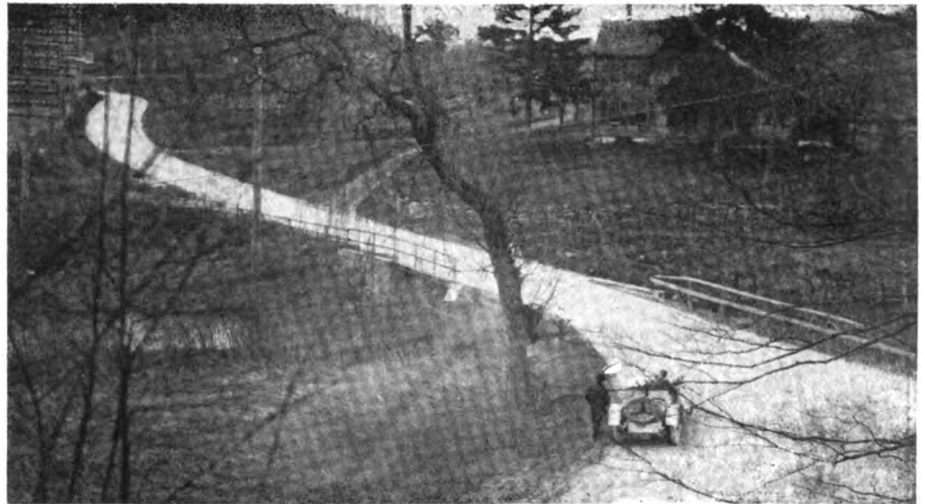

This, One of the Many Windings, Is Near Hawthorne.

"In regard to tires," says S. F. Edge, "the first thing that struck me in running cars at Brooklands was that a certain degree of inflation was the most important point. All previous instructions from tire manufacturers, and others, who should know, were summed up in the words, pump hard. We, therefore,

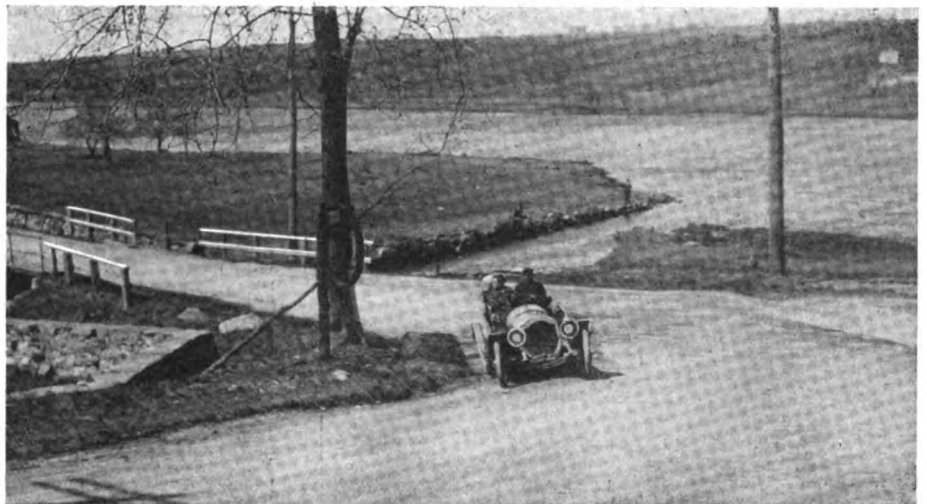

This Turn, in the Vicinity of Kensico, Is Particularly Difficult.

pumped our tires up to the pressure recommended by the tire companies. The result was extreme discomfort at high speeds, owing to the wheels continually leaving the ground; by high speeds, I mean traveling at a rate of 100 miles an hour; in other words, covering the ground at the rate of 146 2-3 feet per second."



Near Mount Kisco, Road Surface Excellent, but Usual Turns Exist.



HOW TO REACH BRIARCLIFF COURSE.

The course in Westchester County for the race follows from the starting point at Briarcliff the main road north-east to Pines Bridge, passing through Millwood and Kitchawan. Turning southeast, it winds down to Mount Kisco, on the Harlem Division of the New York Central, and then runs south through the Wampus Lake section and Armonk,

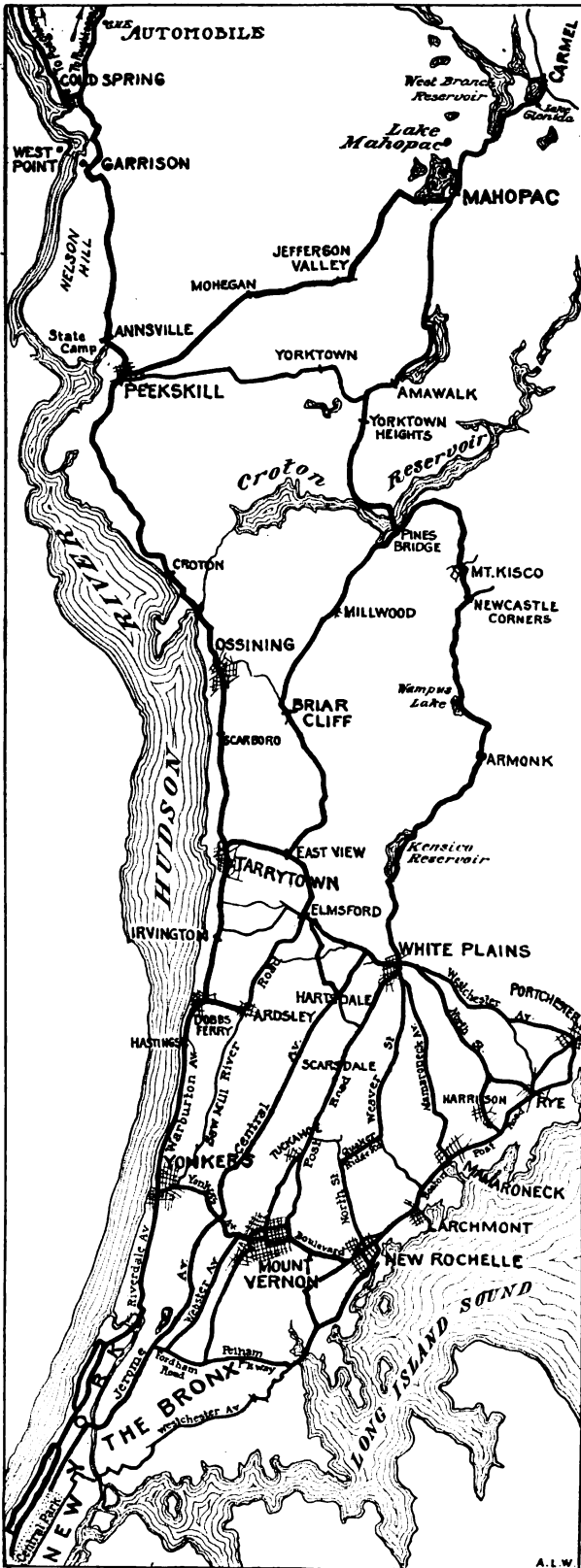

circling the Kensico Reservoir at Valhalla. From Valhalla, it runs directly west to East View and then north through Hawthorne, returning to the starting point. Briarcliff is on the Putnam Division of the New York Central Railroad. Here will be situated the official grandstand. There will be other stands, though, at East View and above Armonk, Valhalla, Hawthorne, and Mount Kisco. Points on the course can be reached by the Harlem Division trains and East View by trolley from Tarrytown.

NEW YORK TO BRIARCLIFF MANOR, N. Y.—32.3 MILES.

Via Broadway, 156th St., Central Bridge, Jerome Ave. and Central Ave. to Hart's Corners (2 miles below White Plains), thence by the new short-cut road to Elmsford and East View. Good macadam throughout.

This is "The Official Automobile Bluebook" Standard Northbound Route to Points in Westchester County or Beyond Briarcliff Manor.

Columbus Circle—59th St. and Central Park West. Run up Broadway to 72nd St.; at subway entrance (on left—7-10 M), keep to right of Monument one block on Amsterdam Ave. Turn left on 73rd St. (8-10 M) and 1st right—again up Broadway (closed to northbound vehicles 72nd to 73rd Sts.).

Follow double car-tracks across 110th St. (Cathedral Parkway—2.7 M), downgrade along elevated "subway," crossing Manhattan St. (3.5 M—caution for trolleys and vehicles from right and left.) Ascend grade, direct to 155th St. (upper boundary of Trinity Cemetery—4.8 M); turn 90° right, straight ahead across 155th St. viaduct onto 5.2 Central Bridge. (No toll, but draw frequently open.)

Straight ahead (leaving trolleys to left—5.4 M), into Jerome Ave. meeting car-tracks from left (5.7 M) follow them across Fordham Road (8.3 M). Continue on Jerome Ave.—several curves, but no turns—crossing (at right angles, just after passing Empire Race-track on right),

13.1 Yonkers Ave.—(About midway between Yonkers and Mt. Vernon.)

The next 7.7 miles (to Hart's Corners) straight macadam—no trolleys or towns of size, but occasional autotraps in the few cross-roads hamlets.

Direct up Central Ave. across Tuckahoe Road (15.6 M), running through Greenville (19.3 M) to Hart's Corners (20.8 M—easily missed at speed, fire station on left, wagon shop on right). Here turn 90° left; 200 feet beyond turn right and immediately left, taking right fork 50 feet beyond, ascending long hill—fine views!

Coming to end of road (21.4 M) turn right, straight ahead through cross-roads (caution for vehicles from right and left), descending—more fine views—to trolley line at foot of hill (23.7 M). Bear left across car-tracks (caution) into the White Plains-Tarrytown road to 4-corners just beyond (immediately before RR.).

23.8 Elmsford.—(A notorious autotrap.)

Turn 90° right, direct 2 3-10 miles to "T" in road at East View (26.1 M—Westchester Co. Alms House on right); again turn 90° right—across concrete bridge (26.9 M), taking left at fork (28.5 M). Thence on main-traveled road running diagonally across Putnam Division, N. Y. C. RR. (dangerous grade—30.7 M); at fork immediately beyond bear right through 4-corners (large stone church on left), at 32.3 Briarcliff Manor—Briarcliff Lodge; Pocantico Lodge (open throughout the year).

NEW YORK TO BRIARCLIFF MANOR, N. Y.—31.9 MILES.

Via Broadway all way across the Harlem River Ship Canal to West 230th St.; thence by West 230th St. and Riverdale Ave. to Yonkers—extended to Dobbs Ferry via Warburton Ave., Yonkers and Hastings-on-Hudson. Turning inland at Dobbs Ferry to the Saw Mill River road, this route reaches Briarcliff Manor via Ardsley and Elmsford. Columbus Circle—59th St. and Central Park West.

Run up Broadway to 72nd St.; at subway entrance (on left—7-10 M), keep to right of Monument one block on Amsterdam Ave. Turn left on 73rd St. (8-10 M) and 1st right—again up Broadway (closed to northbound vehicles 72nd to 73rd Sts.).

Follow double car-tracks across 110th St. (Cathedral Parkway—2.7 M), downgrade along elevated "subway," crossing Manhattan St. (3.5 M—caution for trolleys and ve-

hicles from right and left). Ascend grade, direct to fork (5.5 M just after passing base-ball grounds on left); bear diagonally left with Broadway (St. Nicholas Ave. continues straight ahead), following double car-tracks all way to and under elevated "subway" (8.1 M).

Straight ahead across drawbridge over Harlem River Ship Canal (8.3 M—no toll) to 230th St. (8.6 M—just before left curve of elevated structure). Turn 90° left on 230th St. to end of same at Riverdale Ave. (8.9 M); here turn right, upgrade on macadam. Run direct through Riverdale and Mt. St. Vincent (10.9 M); picking up trolleys (11.3 M) follow tracks to intersection of Main St., 12.8 Yonkers.—Riverdale Ave., Main St. and Warburton Ave.

Park Hill Inn; Francfort's Restaurant, both on Broadway, below Getty Sq. Yonkers Auto Station, 71 S. Broadway.

Straight ahead across Main St., into Warburton Ave., past Manor Hall and Monument (on left—12.9 M), following trolley to and over viaduct at Hastings-on-Hudson (16.9 M). Immediately beyond curve left (leaving car-tracks to right), direct on main road to fork just below Dobbs Ferry (18

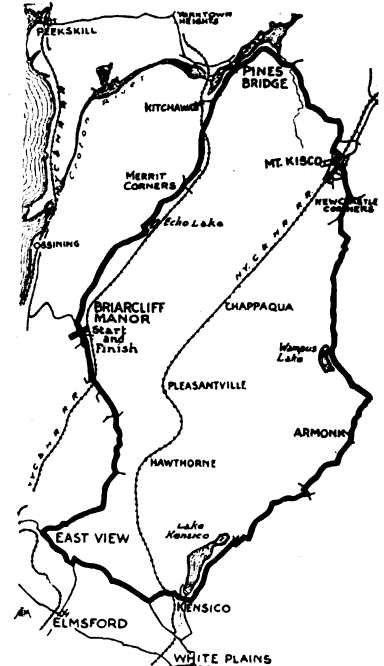

Map of the Course.

M); here (tablet on right marking Washington's Headquarters, 1781), keep right.

Descend grade (18.5 M), passing stone watering trough in road (18.6 M); at fork immediately beyond (18.7 M—light-colored stone church on left), run nearly straight ahead (road to Irvington and Tarrytown takes left). Thence straight ahead on Ashburton Ave. (macadam), crossing RR. at Ardsley station (19.7 M); at drinking fountain just beyond (19.8 M) bear left into the Saw Mill River road.

Avoiding all right-hand macadam forks (uphill), keep on macadam in valley, direct to trolley line at 4-corners, Elmsford (23.4 M). Continue straight ahead (road from New York via Central Ave. and Hart's Corners comes in from the east and turns right), 2 3-10 miles to "T" in road at East View (25.7 M—Westchester Co. Alms House on right); here turn 90° right across concrete bridge (26.5 M), taking left at fork (28.1 M). Thence on main-traveled road running diagonally across Putnam Division, N. Y. C. RR. (dangerous grade—30.3 M); at fork immediately beyond bear right through 4-corners (large stone church on left), at 31.9 Briarcliff Manor, Briarcliff Lodge.—Pocantico Lodge (open throughout the year).



Paul Cornu's Helicopter Which Recently Scored Fairly Successfully Near Paris.

PARIS, April 5.—For the first time, a *helicoptere* machine, built on a large scale, has been able to raise its motor and mechanic from the ground and fly in the presence of a number of spectators. This is the Paul Cornu apparatus, and recently it raised itself about 1.50 meters from the ground. It consists of a tubular frame stayed by cables. The seat of the aviator is placed at the center, as is also the Antoinette motor. By means of a special transmission using flat belts, the latter operates two large screws, 6 meters in diameter, and fixed at the ends of the frame. The entire machine measures 12 meters in length and is dependent entirely upon these screws for its elevation. The propelling and steering members consist of two planes, mounted at the forward and rear extremities of the apparatus, immediately beneath the screws. By means of a lever, the aviator can regulate the inclination of these planes, as well as the speed and the direction of the flight, ahead or astern. A second lever commands the lateral displacement of the same planes, which

then perform the office of steering and permit the machine to go to the right or left. The weight of the apparatus, including the aviator, is 260 kilos, and it is sustained in the air by the turning of the screws at the rate of 90 revolutions per minute. Propulsion is effected by the reaction of the air thrown by the propellers against the planes. A 24-horsepower motor is employed, but in the course of the trials the best results were obtained when the motor was only delivering 12 horsepower.

The aviation section of the Aero Club of America held a meeting at the club's rooms in New York City on Monday.

It developed into an interesting experience meeting, during the course of which various members had adventures to relate and suggestions to make. Lee S. Burbridge, who recently arrived from Europe, where he investigated the status of aerial navigation in France, argued that progress in the air in this country was hampered by the fact that it was not more generally accepted by the public as an accomplished fact.

In the course of the discussion, Albert C. Triaca, chairman of the committee, Daniel L. Braine, Augustus A. Post, and S. Y. Beach were agreed that what the art in this country demanded was sufficient prizes to attract attention and to insure the efforts of American inventors to the solution of the airship problem. Mr. Triaca prophesied that within two months the Wright brothers, who have a contract to build an airship for the government, would show a flight of 100 miles without stop.

For some time there has been a great deal of confidence expressed by those who claim to know, in upholding this opinion.

## A. C. A. ELECTS AND RETIRING PRESIDENT HOYT RECOMMENDS

THE annual meeting of the Automobile Club of America took place Tuesday night at its clubhouse on West Fifty-fourth street, New York City. These officers were elected:

President, E. H. Gary; first vice-president, Henry Sanderson; second vice-president, William G. McAdoo; third vice-president, Robert Lee Morrell; treasurer, Edgar L. Marston; one governor to serve one year, class of 1909, Gen. Horace Porter; three governors to serve three years, class of 1911, Frederick D. Underwood, William Pierson Hamilton, and Waldron Williams; three governors to serve four years, class of 1912, Cornelius Vanderbilt, Colgate Hoyt, and Dr. Schuyler Skaats Wheeler.

In his annual report, Colgate Hoyt, the retiring president, called attention to the fact that he is still of the belief that the A. C. A., and apparently not the American Automobile Association, with its 200 clubs, should be the national organization of the country. The manufacturers of automobiles are told by Mr. Hoyt that they are now sufficiently strong to conduct their own shows, "without our support or assistance, and that the club should now retire from the field."

Attention is called to the successful good roads and good laws conference held by A. A. A. clubs at Springfield, Mass., last September, and which will be repeated in a national manner at Buffalo on the two days preceding the start of the annual A. A. A. tour for the Glidden and Hower trophies. Mr. Hoyt recommends that the A. C. A. organize such a congress, seeming to consider that the Buffalo affair will not be sufficient to answer the needs of the situation. Mr. Hoyt also recommends that there

"be held this spring or summer an international touring car trial, somewhat on the lines of the trial to be held by the Royal Automobile Club of Great Britain, to provide an exhaustive test of touring cars, each car being given a definite rating under a standard formula, and that an exhaustive tire test be held in connection with such trial."

Reference is made to the fostering of inter-club relationship, and the statement is made that an agreement has been reached with the Massachusetts Automobile Club. It is a well-known fact that the A. A. A. clubs throughout the country now have an existing understanding concerning reciprocal courtesies, though Mr. Hoyt ignores this fact.

The statement is made that the A. C. A. declined to endorse the Federal Registration Bill of the A. A. A., on the ground that it is unconstitutional in its provisions. Mr. Hoyt calls attention to the rejection (?) of the bill by the Judiciary Committee of the House of Representatives, though Chairman Jenkins the other day publicly stated that his committee had yet to reach a decision.

Mr. Hoyt mentions the activities of A. R. Shattuck in good road matters. Mr. Niles is also commended for his services.

The total cost of the new clubhouse is placed at about \$800,000, the total mortgage obligations of which is now \$610,000, \$40,000 of the second mortgage bond having been cancelled during the past year with the club's show profits, initiation fees from new members, and fees from life memberships. The present active membership is 1,223, with 30 life members, and 287 associate members. The net gain in membership during the year was 291.

## FOREIGNERS DECLINE TO WAIT AND SAIL FOR JAPAN

BY way of reward for having gained sufficient lead to investigate Alaskan conditions before any of its competitors could follow, the Thomas now finds itself a tail-ender, bound back for Seattle on the steamer *Bertha*, while the *Zust* and *De Dion* crews, who were a fortnight behind it at San Francisco, are on the *Aki-Maru*, bound for Yokohama, Japan. Lieutenant Koepfel, of the *Protos* crew, who is at Seattle, announces his intention of sailing for Vladivostok with the Thomas, even if necessary to ship the car from Ogden, Utah, where it is now undergoing repairs. This would naturally cost the German car its status as a contestant. The *Zust* crew left Seattle in charge of Heinrich Haaga, the mechanic, Sirtori's frequent differences with the management having caused his contract to be summarily terminated at Seattle. According to R. W. Volmoeller, of the *Zust* Company, who is now in New York, the shipment of the *Zust* with the *De Dion* was contrary to explicit orders to await the arrival of the Thomas, and to sail with the latter direct to Vladivostok. Mr. Volmoeller declared it was necessary to do this in view of the agreement with the Thomas Company, in anticipation of the possibility of being unable to cross Alaska, due to the thaw.

The Thomas crew received as enthusiastic a reception at Valdez as the entire population of that frontier settlement could possibly provide, and were taken out to Keystone cañon the day after their arrival to investigate conditions. They went as far as Comfort Camp, the first station on the trail to Fairbanks, with the aid of a one-horse sleigh, and tests showed that it would be utterly impossible to proceed over the same route with a heavy car. It was the consensus of opinion that the chances would not be much better, even in winter, and it did not take George Schuester long to make up his mind to return, the Thomas being put aboard the *Bertha*, which sailed the following day on the return trip to Seattle.

According to advices from Seattle, the *Bertha* is due there Friday next, April 17, and the Thomas will be immediately transferred to the steamer *Glenlogan*, leaving on Saturday direct for Vladivostok. With good weather, the passage should not exceed 20 days, so that the Americans should arrive in Siberia on May 7, not more than two or three days after the French and Italian crews, and if the latter should miss connections in Japan, might reach that country before them.

The following statement issued by the E. R. Thomas Company last Saturday, throws an interesting side-light on the matter, the conclusion of which may involve international correspondence:

"The announcement that the Thomas Flyer, America's entry in the New York to Paris race, is returning to Seattle from Alaska, has put the whole outlook of the race in a peculiar light, and one which raises some interesting questions. Perhaps the American car has already won the race without continuing the race to Paris. In the original rules, which were, however, very vague, it stated that should the journey not be continued, the winner would be that car which went the farthest on the original route. This the Thomas has done by going to Alaska, and it is altogether unlikely that any other car will go by way of that country.

"The Thomas car has lost the lead of two weeks which it had on its nearest competitor at San Francisco, through a lot of strategy which was played by the foreigners. Arriving at San Francisco, about a thousand miles ahead of the race, there was no opportunity for any conference nor any decision as to the future course, and it remained for the Thomas car either to await the coming of the other competitors or to start on the route originally planned. No satisfactory direction nor explanation could be received from the officials and committees in charge of the race and, therefore, the car was shipped to Valdez by the steamship *Santa Barbara*. Upon their arrival at Valdez the American crew apparently discovered what people familiar with Alaska had already surmised—that the roads were absolutely impassable—and it remained for them to retrace their course to Seattle. Here they will find the Italian and French cars, and it is altogether probable that the three cars will be shipped direct to Yokohama, continue thence to Vladivostok and by the Central Asiatic route, rather than by the north coast. This will put America's champion again back on an equal footing with its two nearest foreign competitors and within halting distance of the third. The lead of about a thousand miles, or, reckoned in days, of about two weeks, which it had upon the foreigners at San Francisco, is lost.

The advantage which it would have had by arriving in Alaska on an earlier steamer, is also lost. It now has no advantage over the foreigners, except its reputation, its crew of American experts and the excellence of its American manufacture. On the other hand, it now has an opportunity to win this race for the third time. It has already defeated the entire field by a sufficient margin to prove finally and conclusively that it is the best car for American road conditions and American road travel. Secondly, it has won the race according to the original rules, by going farther over the original course than any of the other competitors. It now remains for the Thomas, starting on an even footing with the foreigners on foreign soil, to demonstrate its superiority over these cars on their soil as conclusively as it did in its own country.

E. R. Thomas Motor Company.

Buffalo, N. Y., April 11, 1908.

## MAXWELL WINS A THOUSAND-DOLLAR CROSS-COUNTRY

PITTSBURG, PA., April 13.—The Maxwell-Reo \$1,000 match race to Philadelphia and back ended this morning in the victory of the Maxwell. C. W. Kelsey and Joe Emerling, its initial and homestretch pilots, arrived here at 9:30 o'clock this morning, having made the round trip of 592 miles in 44 hours. E. L. Seeley and Greenwood, his mate, who manned the Reo, did not reach the finish until 18 hours later.

The match was the outcome of a series of advertising challenges published during the Pittsburgh show. The Reo agent was stirred up by the Pelletier publicity methods, and declared he would "call the Maxwell bluff," so he offered to make an endurance run match to Philadelphia and back for \$500 a side. The Maxwell folks did not like the "bluff" innuendo a little bit, and promptly accepted the challenge. The terms were more quickly arranged than is generally the case in these exchanges of advertising compliments between dealers, and with no superfluous nonsense over conditions beyond the agreement that each car should carry an observer acting for the other, an out and out race was arranged.

The race was started at 1:30 o'clock on Saturday afternoon, the route laid out being in order through Laurel Ridge, Bedford

Springs, Gettysburg, York and Lancaster, much of which was embraced in the course of last year's Glidden tour. The Maxwell arrived at the Bellevue-Stratford in Philadelphia at 11:30 o'clock on Sunday, Kelsey and Emerling having covered the intervening 296 miles in 22 hours. The Reo was over six hours behind, not arriving until 6 o'clock, having been detained by an accident.

The Maxwell at once started on the return trip. Longstreth and Gates, of the Maxwell-Briscoe Philadelphia branch, were its pilots as far as Bedford Springs, where Kelsey and Emerling again manned the car for its run over the homestretch to Pittsburgh. The return run was made in exactly the same time required for the outward bound trip. The first and last 100 miles of the route was rough going up and down hill and through mud. The remaining 400 miles was over macadam most of the way with altogether excellent traveling, the season of the year being considered.

The winning car, which was shod with Ajax tires, had good tire luck, sustaining but five punctures during the long 592 mile run, despite the fact that rough mountain roads had to be traversed for one-third of the distance.

# New York's Successful Carnival Means Annual Event

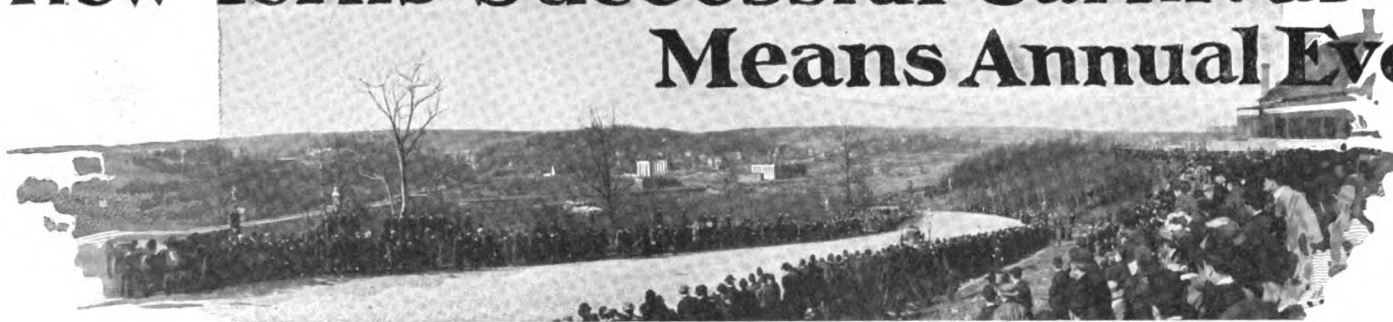

From the Top of Fort George Hill a Magnificent Panorama Is Presented of the Country for Miles Around.

"CARNIVAL WEEK," as a formal inauguration of the business season and as a "get up" to the automobilist from his long winter sleep to the realization that spring, with all its joyous saunterings and delightful tours, is at hand, is now assured as an annual fixture on the metropolitan outing calendar. The phenomenal success of last week's New York automobile celebration, backed by triumphs along the same line in Chicago and Indianapolis, makes the spread of the spring carnival idea all over the country by next year more than a mere probability.

As an eyeopener to the extent of automobiling and the magnitude of the motor car industry, New York's carnival was a revelation. A half million people turned out to see Tuesday night's parade. Ten thousand more faced a chilling wind to watch the cars climb Fort George hill on Thursday afternoon. To the practically universal decoration of the hundred or more buildings devoted to New York's trade was added a remarkably widespread decorative emulation by the great hotels and big restaurants along Broadway until an embellishment was attained seldom surpassed even on the occasion of great national celebrations.

And what of results? Just here comes an illustration of the carnival spirit that pervaded the local tradesmen. Their main idea was the success of the carnival as a celebration and demonstration of the sport and industry first, last, and all the time. As a matter of fact, they have been too busy with helping and hurrahing to permit so insignificant a matter as their own personal resultant benefit to intrude upon their discussion of the carnival. They were out to wake up New York; to dispel pessimism; to arouse the public to the permanency and greatness of the automobile rather than to put in six days to pulling purchasers into their sales-rooms. They all had a lot of visitors, gave many demonstrations, and made sales, some more, some less. They are willing to let it go at that. But every one of them believes the much too prevalent pessimism of the past winter has been scattered to the winds and that a harvest will follow, wherein will be reaped a crop in satisfactory proportion to the reduced output of an off year following a financial panic and embracing the business-halting conditions of a presidential election.

The energy and the *esprit de corps* displayed in the promotion of the carnival have been among its most gratifying and encouraging features. "Automobile Row" has proved it pos-

sible to pull together when the common weal has been at stake. Dealers have come to know one another better and to realize what really good, hard-working, honest fellows make up the local trade fraternity. The "Knockers' Club" will now lose many of its members to the "Helping Hand Society."

The committee in charge, with General John T. Cutting, who was at the bottom of the start of the carnival and to whose energy, youthful enthusiasm, and limitless unselfishness much of the success of the carnival is due, at its head, did splendid work, each separate department looking after its own details without a hitch.

Colonel K. C. Pardee, chairman of the hill climb and parade committees; R. G. Howell, grand marshal; Walter R. Lee, secretary of the New York Automobile Trade Association, and C. W. Wurster, who looked after the advertising and publicity, proved able executive heads, but worked no harder and no more efficient than did Percy Owen, Frank Eveland, C. R. Teabolt, C. P. Skinner, R. W. Newton, and Alexander Howell, their associates on the executive and finance committees.

The response of the trade was generous to the call for contributions. Some \$8,500 was subscribed to the general fund. General Cutting says that the raising of \$20,000 next year will be easy. It is planned to make next year's carnival far more elaborate, and have the week not only embrace a parade and hill climb, but racing and other contests as well; in fact, a varied program.



Starting at the Bottom of the Grade.

## Story of the Fort George Climb.

How great an interest had been aroused, not only among automobilists but also the public at large, in the carnival was attested by the enormous crowd in attendance at the hill climb, which took place on Fort George hill on Thursday afternoon. Every point of vantage at the top and even at the bottom of the grade was occupied by automobiles. The crowd was massed at the start and finish, packed along the curb on either side, and perched upon the rocks on the precipitous hillside. There could not have been far from 10,000 onlookers. The throng was well repaid for facing a stiff wind, more than bordering on the merely chilly, by a series of snappy uphill rushes that kept interest at fever heat from start to finish. The management of the affair and the promptness of the dispatch of the climbers were perfection itself. That 71 cars were started, finished and timed in 109 minutes gives an idea of the efficient handling.





No 66 STEVENS DURYEYEA



No 37 CORBIN

No 12 JACKSON



ROBERT GUGGENHEIM RENAULT AMATEUR

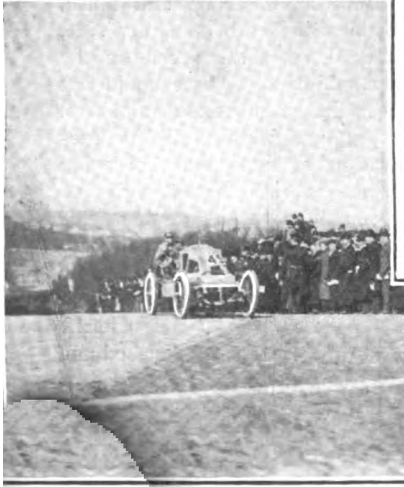

R.S. CRAWFORD AMERICA'S OLDEST COMPETING DRIVER

No 71 WHITE STEAMER

### FORT GEORGE HILL CLIMB RESULTS.

#### Open Free-for-All. All Types and Motive Power.

No.	Car	H.P.	Price	Driver	Time
71	White	30	\$3,700	Walter C. White...	0:32 1-5
70	White	30	3,700	Walter C. White...	0:32 2-5
69	Apperson	62	8,000	Edgar Apperson...	0:36
76	Fiat	60	Special	Emanuel Cedrino...	0:37
75	Stevens-Duryea	50	6,000	P. J. Robinson...	0:37 3-5
50	Apperson	62	7,500	Edgar Apperson...	0:38
73	Matheson	60	7,500	J. B. Ryall...	0:40 2-5
74	Pope-Hartford..	30	2,950	J. P. Grady...	0:42 2-5
77	Knox	30	2,650	William Bourque...	0:43 4-5
67	Pennsylvania ..	50	3,000	Leonard Zengle...	0:45 1-5
68	Renault	35-45	8,000	Robert Guggenheim.	0:47 4-5
79	Stoddard-Dayton	40	2,700	H. S. Hodson.....	0:49
72	White	20	2,500	Clarence H. Lane...	0:52 1-5

#### Six-cylinder Gasoline Cars, Over \$4,000.

66	Stevens-Duryea	50	\$6,000	P. J. Robinson.....	0:38 4-5
65	Stearns	45-90	6,250	Guy Vaughn.....	0:46 4-5
63	Hotchkiss	65	4,000	Charles Gatzten....	0:52 3-5
62	Acme	45	4,250	Adam Arnold.....	0:55

#### Four-cylinder Gasoline Cars, \$4,000 and Over.

57	Stearns	30-60	\$4,600	Guy Vaughn.....	0:42 1-5
59	Stearns	30-60	4,600	D. E. Farrell.....	0:42 2-5
58	Stearns	30-60	4,600	Kingsley Swan.....	0:42 3-5
61	Stearns	30-60	4,600	L. M. Travis.....	0:42 4-5
52	Simplex	50	5,750	Frank Lescault....	0:43 3-5
51	Simplex	50	5,750	Carl Broessel.....	0:44
64	Stearns	30-60	4,600	A. J. Picard.....	0:44 3-5
55	Stearns	30-60	4,600	Barney Oldfield....	0:46
60	Stearns	30-60	4,600	Halstead Swan.....	0:46
56	Stearns	30-60	4,600	Arthur Warren.....	0:47
85	Stearns	30-60	4,600	Irving Pickling....	0:48 3-5
49	Renault	35-45	8,000	Robert Guggenheim.	0:49

#### Steam, Gasoline or Electric Cars, \$2,001 to \$3,000.

37	Corbin	30	\$2,500	J. W. Swan.....	0:42 4-5
40	Knox	30	2,650	William Bourque....	0:45
36	Corbin	30	2,650	W. G. Barbour.....	0:48 4-5
39	Pullman	40	3,000	F. Cimiotti.....	0:49 4-5
41	Knox	25-30	2,500	Jerry Lynch.....	0:52 4-5
38	White	20	2,500	Clarence H. Lane...	1:07

#### Gasoline Cars, \$2,001 to \$3,000.

18	Corbin	30	\$2,500	J. W. Swan.....	0:43 4-5
34	Knox	30	2,650	William Bourque....	0:46 2-5
20	Pope-Hartford	30	2,950	J. P. Grady.....	0:47
19	Stoddard-Dayton	40	2,750	Charles Miller.....	0:47 4-5
15	Pennsylvania ..	50	3,000	Leonard Zengle....	0:49
21	Pope-Hartford.	25	2,650	J. P. Grady.....	0:49
22	Pope-Hartford.	30	2,950	Philip Heiner.....	0:50
17	Corbin	30	2,650	W. G. Barbour.....	0:50
28	Pope-Hartford.	25-30	2,950	C. Pentoney.....	0:50 1-5
26	Pullman	40	3,000	F. Cimiotti.....	0:49 4-5
16	Stoddard-Dayton	40	2,700	H. S. Hodson.....	0:54 2-5
23	National	45	3,000	D. C. Teetor.....	0:55 4-5
27	Glide	45	3,000	J. C. McCaffrey....	0:58 2-5
32	Crawford	40	3,000	R. S. Crawford....	0:59 4-5
29	Oldsmobile	35	2,750	Arthur Weisbecker.	1:00 1-5

#### Gasoline Cars, from \$3,001 to \$4,000.

46	Stevens-Duryea	35	\$3,500	P. J. Robinson.....	0:45
45	Cleveland	40	3,500	Frank McCaffrey....	0:55 3-5
47	Mora	42	3,500	W. W. Burke.....	0:58 3-5
44	Allen-Kingston.	40-45	3,900	Ralph de Palma....	1:05 1-5

#### Steam Cars Only.

82	White	20	\$2,500	Charles H. Lane....	0:54
----	-------	----	---------	---------------------	------

#### Gasoline Cars, from \$1,251 to \$2,000.

12	Jackson	35	\$2,000	Bob Burman.....	0:52 3-5
9	Corbin	24	1,250	Harry B. Tucker....	0:55 4-5
8	Aerocar	30	1,850	Chris White.....	0:58
7	Mitchell	35	2,000	A. D. Edgerton....	1:00 3-5
10	Maxwell	24	1,750	Charles Fleming....	1:02 2-5
11	Pullman	20	2,000	R. Morton.....	1:05 2-5
14	Oldsmobile	32	1,900	E. Stuenwald.....	1:11 1-5

#### Electric Cars, All Types.

3	Mitchell	20	\$1,000	Ward Olney.....	1:07 1-5
5	Reo	16	1,000	R. L. Lockwood....	1:14 1-5
6	Overland	22	1,250	Thomas Forbes....	1:14 1-5
4	Jackson	22	1,250	Bob Burman.....	1:34 3-5

#### Gasoline Cars, \$850 or Under.

1	Maxwell	14	\$825	Charles Fleming....	1:19 1-5
2	Maxwell	14	825	J. Ross.....	2:22 1-5

#### Gasoline Cars, from \$851 to \$1,250.

84	Babcock	3	\$1,500	H. E. Wagner.....	1:24
83	Babcock	3	1,700	Robert Clyde.....	1:49 3-5

No 57 STEARNS



No 3 MITCHELL

No 1 MAXWELL



EDGAR APPERSON AND BLACK DICK



R.S. CRAWFORD AMERICA'S OLDEST COMPETING DRIVER



The White Steamer, Winner of the Free-For-All, in Full Whistling Cry on Its Upward Journey to the Finishing Point.

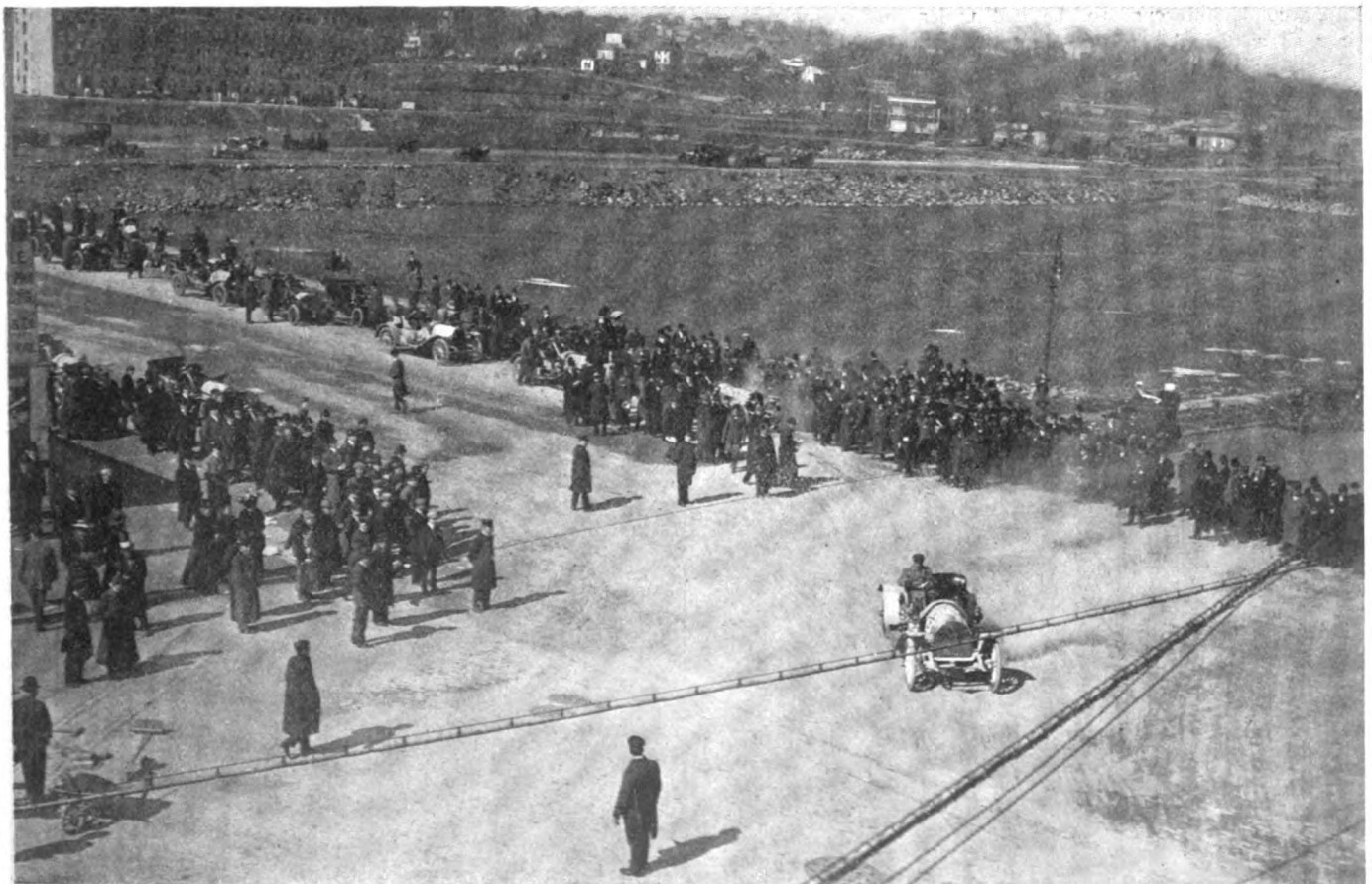

Before the Climb Began the Cars Were Lined Up at the Bottom, and Starter Wagner Thus Made His Work the Easier.



Rocks Supplied Uncomfortable Vantage Points.



Packard's Truck Sturdily Made the Climb.

With A. R. Pardington as referee, Fred J. Wagner as starter, and the New York Timers' Club in command of the timing machine, S. M. Butler, C. J. Dieges, Lieutenant P. A. Sayles, and E. LeRoy Pelletier holding the watches, everything moved with the precision of well-oiled machinery.

The enthusiastic co-operation that marked the progress of the whole carnival was in evidence in the response of the dealers to the call for entries, 71 cars actually starting in the 11 events scheduled. The contests were essentially dealers' demonstrations, for with the single exception of the free-for-all, every event was for stock cars and stock cars with every bit of equipment carried at that. The difficulty of the climb was greatly enhanced by a start from an absolute standstill with a run-in of less than 200 feet before the actual climbing began, the time, be it remembered, being taken from the actual start of the car and not from the time of its beginning the ascent. In last year's contest with a flying start, Frank Leland set a record mark of 29 seconds with a six-cylinder Stearns. The estimate of 10 seconds difference to the bad under this spring's conditions as compared with last autumn's was confirmed by that drop in times of the average of the big Stearns brigade. The Fort George hill course, over which the cars were timed, is a 1,900 foot stretch of Belgian block and a finishing stretch of macadam, with an average rise of 11 per cent.

The high speed honors of the climb were carried off by Walter C. White, who captured the free-for-all trophy and also the cup offered for the fastest time, with a score of 32 1-5 seconds. The White steamers gained added laurels by Walter White's putting across the tape a second car in :32 2-5, thus capturing second speed honors as well, and by a stock car of this same make also winning the event for steam machines.

Edgar Apperson proved his Apperson to be the fastest of the gasoline contenders by a record of 36 seconds in the free-for-all. Referee Pardington, by the way, barred this Apperson "Black

Dick," which was said to be a counterpart of the company's Vanderbilt Cup racer of 1906, from the stock car class on the ground that it did not comply with the stock car conditions of the rules.

The best climber in the stock car division evolved in the Stevens-Duryea "Big Six," which, piloted by P. J. Robinson, captured not only the \$3,001 to \$4,000 gasoline event, but the six-cylinder cup as well.

Four-cylinder gasoline stock car supremacy perched upon the banners of the Stearns, Guy Vaughan winning the \$4,000 and over event in 42 1-5 seconds.

A double victory went to the Corbin, J. W. Swan capturing not only the \$2,001 to \$3,000 gasoline climb from the biggest field of the day, but the all-type class with the same price limitations.

The other gasoline events went to a Maxwell in the \$850 and under, a Mitchell in the \$851 to \$1,250, and a Jackson in the \$1,251 to \$2,000 class. H. E. Wagner carried off the electric cup, his Babcock making the ascent in 1:24.

A score of carloads of enthusiasts braved the storm and ploughed through the mud on Friday night to make good the "joy ride" feature of the carnival program, which had Bronxville as its objective point and a dinner at Grammatan Inn as its wind-up. There were 171 tickets sold for the banquet and 125 were on hand at the door with their meal tickets; many, of course, had come by train. At the conclusion of the dinner, General Cutting circled around among the tables and jollied the newspaper boys and others into indisputably impromptu speeches.

Carnival Week wound up with the presentation of the prizes at the vaudeville smoker, given by and at the Automobile Club of America. Following the presentation of the prizes, a surprise was sprung on General Cutting by Col. K. C. Pardee, presenting to him a handsome silver loving cup on behalf of his associates on the carnival committee.

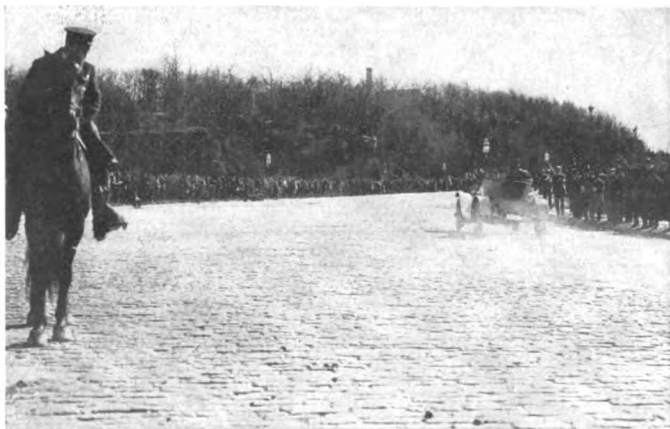

Very Efficient Were the Police Guard.



Referee Pardington and Chairman Thompson.





**L**ONDON, April 10.—There is no necessity to visit Olympia to know that the Britisher is intensely interested in the application of motor vehicles to business purposes; a run through the streets of the capital is sufficient. But to realize to what extent the commercial vehicle has taken a hold on the Britisher, the big inartistic Olympia hall at West Kensington should be entered. Right here credit should be given to the Englishman for the preponderating position he has won in the commercial vehicle world. Though working under the disadvantage of a late start, and having his doors wide open to all foreign products, he is fully master of his own market, as is shown by the proportion of British and foreign firms at the second annual commercial vehicle and motor boat exhibition, organized by the Society of Motor Manufacturers and Traders.

America has as her sole representative in the vehicle class a Frayer-Miller truck and engine, shown by the Darwen Automobile Agency, recently appointed sole representatives for the Oscar Lear Company in the British Isles. McCord oilers were handled by an agent, and Goodrich tires occupied a large stand under the name of the British representative. France had as its chief representatives, Renault, Berliet, De Dion, Darracq, Darracq-Serpollet, Georges Richard and Royal. Italy had Fiat; Germany had a couple of representatives; Switzerland one; but the rest—and they were a large majority—were British firms.

Three distinct classes might be formed of the commercial vehicles prominent before the British public. The taxicab, together with the light delivery wagon, the two being one so far as mechanical features are concerned, occupy first position. Large passenger vehicles for service in connection with railroad companies come second in importance, closely followed by gasoline and steam trucks, of from two to ten tons load capacity. This year the motor 'bus is in the minority, probably owing to the fact that in the metropolis, at any rate, the supply has exceeded the demand. Passenger vehicles for other services, however, such as auxiliary railroad work, feeders in connection with surface cars, and observation automobiles in holiday resorts are plentiful. For heavy traction, steam more than holds its own in England, and for vehicles carrying but three ton loads there is keen competition between the two systems.

**Taxicabs Are Now the Center of Interest.**

In the taxicab field, the French lead in workmanship and the British appear to have the advance in originality. Darracq, Renault and Unic each present a type of cab excellent in workmanship, but which cannot be considered as other than a reduc-

tion of the touring models. The new Renault has three-quarter elliptic springs in the rear, but otherwise is similar to those in use in New York. One improvement has been made, and this applies equally to all foreign taxicabs, by the cutting away of the driver's double seat and utilizing the space gained for carrying baggage. On the Fiat, additional width is obtained by a leaf folding over the running board. Suitable hangers and a broad strap allow of attaching the trunk in position on the driver's left hand.

Among the British makers there is a strong tendency to get away from the touring car standards and build the taxicabs with the engine forward, but under the driver's seat. A very good example of this is shown in the new Austin cab,

in which the four-cylinder engine in one casting is immediately under the driver's seat, the pedal connections being under the foot-boards and the gasoline tank on the dash. For all ordinary purposes, the engine can easily be reached through side doors, or can be fully accessible by taking down the seat. This disposition of the power plant brings the gear box right under the body of the cab, necessitating the lifting out of the floor boards before it can be reached. The driver's seat is centered and rather higher than usual, owing to it being above the engine. For cab work, the pronounced tendency is toward single ignition by high tension magneto, thermo-syphon water circulation and small compact engines in one casting; in these features the British designers are in harmony with those of the Continent, and it is quite evident that they have been following closely along very similar lines to those adopted by their French and German competitors in the same field of endeavor.

On the Lotus car was employed a 12-18-horsepower two-cylinder "V" engine, also under the driver's feet, with valves, carbureter and ignition occupying the angle formed by the two cylinders. So far as compactness is concerned, the arrangement is an excellent one, the removal of the floor boards uncovering the entire engine, making every part as accessible as it would be on a vertical type. On this car the use of planetary trans-

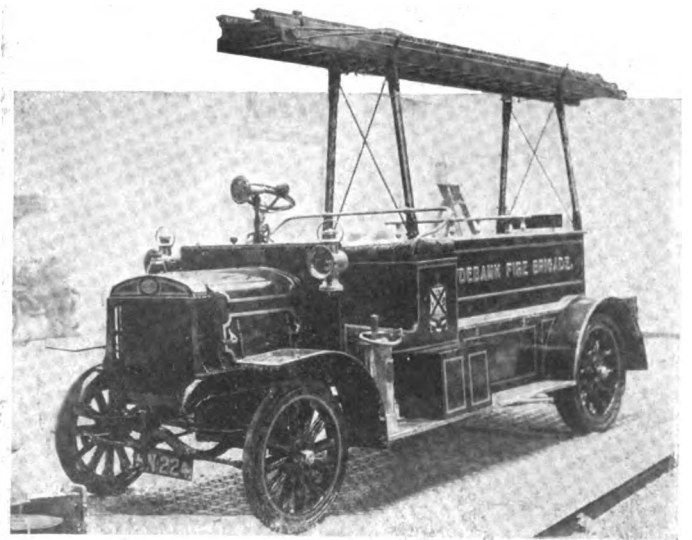

One of the Latest Types of British Auto Fire Engines.





The Taxicab as Exemplified in the Beeston-Humber.

mission and spur gear differential gave a smack of Americanism, European designers as a rule adopting sliding gear transmission, even for the smallest powers.

#### Broughams for Commercial Travelers.

A side issue of the taxicab business is the construction of commercial travelers' broughams. Mechanically, this type of vehicle is identical with the taxicab, but in bodywork there is considerable difference. Thus, on the De Dion stand was shown one of these vehicles with a single cylinder ten-horsepower engine and closed body, with only one inside seat, the remaining place being occupied by a series of drawers, cupboards and trays. As English commercial travelers have to operate over big but closely populated areas, in which both trains and street

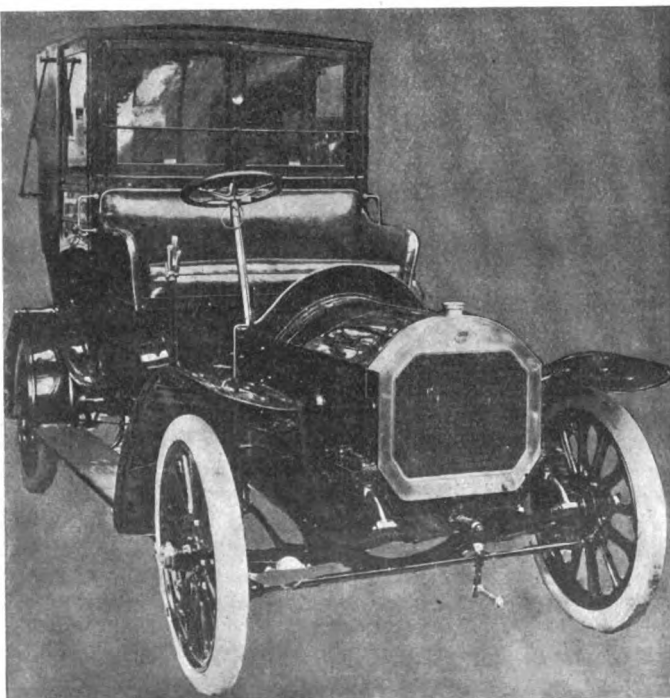

Unic Taxicab, Another Newcomer at Olympia Show.

cars can be of little service, an economical vehicle of this type should have an immense success.

In the lightest type of delivery vehicles there was a surprising scarcity, in view of the fact that English retail trade is still largely held by small and medium-sized firms having quick deliveries to make. In this class the only vehicle which attracted attention was the Royal, with the entire power plant over the rear axle, leaving nine-tenths of the wheelbase free for bodywork. Single-cylinder engine, gear box and drive were all lodged transversely in the rear of the frame, as accessible when the seat was removed as if on a shop bench; the only part in connection with the engine which was carried forward was the radiator under the front end of the body. Engine control was exclusively by variable exhaust lift.

#### Delivery by Motor Vehicles Is Booming in England.

For loads of from one to five tons, and still higher, by the use of steam tractors, there is a display at Olympia which proves conclusively that the British merchant is desirous of something more efficient than horse delivery service. The interesting feature about the entire exhibit is that commercial motor manufacturers do not show a chassis only, but series of vehicles completely fitted for different classes of trade. To the business man, the feature is an important one, for, though he is interested in good mechanical construction, he is equally concerned about load capacity, carrying surface and convenient handling. Practically every branch of trade is represented, in many

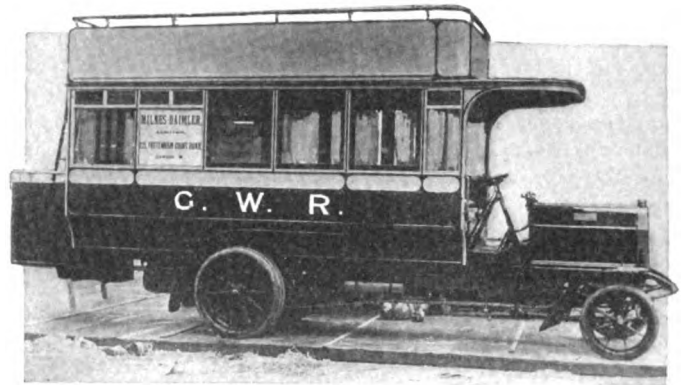

Auxiliary Railway Auto of Heavy Carrying Capacity.

cases vehicles which have been in use with well-known metropolitan houses being shown loaded up for daily work.

From one to three tons gasoline holds its own, steam being in a decided minority, and electric transmission very feebly represented. Electric trucks are entirely absent; indeed, the only vehicle in the exhibition obtaining its power from storage batteries is an electric 'bus, representing a line recently put in operation in London. For three-ton loads and above, steam is a serious rival of gasoline, and for the heaviest types of traction, as, for instance, breweries and the building trades, is in a leading position.

Engine design for trucks follows well defined lines in general principles with considerable diversity in details. Excepting the American Frayer-Miller, there are no air-cooled engines, and but few examples of kerosene or alcohol-driven motors. Four-cylinder water-cooled vertical engines, either forward under a bonnet or below the driver's seat, are the standard type. It is in transmission, and especially in final drive, that diversity of design is apparent. Sliding gear, a countershaft and side chains, as in heavy touring car practice, hardly occupies first position in the commercial field. Parenthetically, it may be mentioned that where this type of drive is employed chain cases are always fitted. Cardan shaft, with final drive through rear live axle, strengthened for the heavier work it has to perform, is prominent for the medium weight truck, while worm drive is noted in many cases. Internal spur-gear final drive was noted in a number of cases on the more powerful units.

The commercial steam automobile, being really a development of the traction engine, the construction of which was carried on long before Britain was freed from the red flag law, it was natural that a nation that has always led in steam engine work should turn to the tractor for heavy road work.

**Automobiles Compete and Co-operate with Railroads.**

For country haulage, for use by market gardeners, millers, brewers, etc., the steam tractor, carrying a load of three, five or

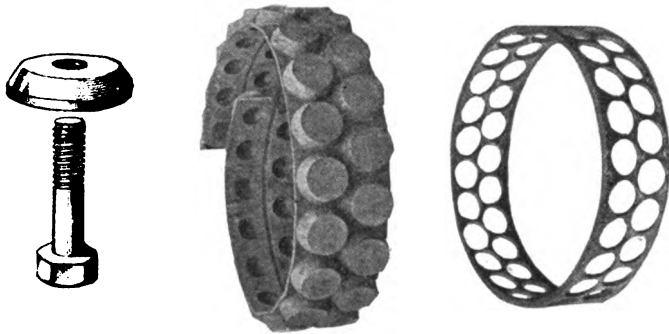

Component Parts of New Cushion Tire for Trucks.

six tons, and capable of taking up to ten tons, by means of trailers, has won a strong position in England. A large number of the manufacturers of these vehicles hail from the coal, iron and woolen manufacturing districts of the North, where steam engineering has always been well developed, and where heavy traction in connection with the varied industries is common. Under the Motor Car Acts, these vehicles are allowed to run at a speed of eight miles an hour with steel tires, and twelve miles an hour with rubber tires. Especially in the Northern manufacturing districts they are now being extensively used, not only as an auxiliary of the railroad, but competitively for journeys of less than forty miles in length.

Owing to their use with and without trailers, and at different legal speeds, provision is made on many of the steam tractors for the convenient changing of road wheels, steel bandages being employed for country work in summer, rubber for town service without trailer, and timber-faced wheels over greasy or frozen roads. A good type of changeable wheel was noticed on a Sentinel steamer, the fixed wheel being one shaped and the dismountable part being shaped to fit over it, attachment being by lugs on the dismountable rim to take bolts passing through holes on a fixed felloe.

A very convenient type of gasoline tank filler was seen on an Arrol-Johnston 'bus chassis. The tank, which was under pressure at the rear, had a projecting pocket 4 inches in diameter by 10 inches deep, fitted with a bucket strainer. Gasoline could thus be poured in without the use of a funnel, and should any of it be spilled there was no danger of it running over the woodwork of the car. With the increase of motor 'buses and taxicabs in the city of London, special police regulations have been brought out to protect against fire, one of them being the carrying of a fire extinguisher on each vehicle.

**Payment on Results Is Now Practiced.**

Though not a very common practice, it was learned in conversation with exhibitors that several firms supply their vehicles to business houses at a fixed monthly rental covering all costs. The manufacturer undertakes to have the vehicle at the disposal of the customer, in charge of one of his own drivers, for a certain number of hours per day, and to keep it in working condition on the terms stipulated. Though the arrangement is one of limited application, the fact that it is being entered into by reliable firms is conclusive proof of the strong position that the commercial vehicle has attained here.

A new type of cushion tire displayed in the well-fitted accessory section consisted of lengths of rubber with projecting rubber

studs forced into a perforated steel rim, so that the studs will project. The bases of the air spaces are closed by the insertion of steel dives or washers, some of which are tapped to take the screw ends of bolts. The cushion tire thus formed is forced over the felloe of the wheel, a few bolts being passed through the felloe and binding rim into the tapped washers to make all secure.

**REPAIRING A CRACKED CYLINDER JACKET.**

The accompanying figure shows a cylinder which has been cracked by frost, writes T. W. Holloway in *The Engineer*. Making good such a cylinder jacket may appear to be a very difficult job at first sight, but upon second consideration it will be apparent that there are a number of different ways in which it may be effectively repaired with few facilities. First drill a 1-4-inch hole at the end of the crack shown at A, to prevent it from extending further, then shrink a steel or iron band on the end of the cylinder as shown at B. Then take a chisel about 3-16 to 1-4 inch wide and cut a groove along the line of the crack, making the groove widest at the bottom, as shown at C. Next secure a piece of 1-4-inch copper wire which has been well annealed and hammer it tightly into the groove. By careful calking, a crack of this kind can be made perfectly tight. The copper wire can readily be annealed by heating it and then cooling it suddenly by plunging it into water.

If the crack extends only a short distance as D E, it is not necessary to shrink a band on the jacket, but a hole can be drilled at each end of the crack and the dovetailed groove cut and the copper wire hammered in and calked as previously explained.

Sometimes a short crack is repaired by drilling a series of 1-8 or 3-16-inch holes as close together as practicable for the entire length of the crack, the first and last holes being at the extreme end of the crack, as shown at F G. The holes are then tapped out and cast iron or metal plugs, which are sometimes made for the purpose, are screwed into the holes and cut off even with the surface of the jacket. The job is then completed by rusting in with sal ammoniac.

A very small crack is sometimes rusted up with a saturated solution of sal ammoniac which is poured into the jacket. The solution is then forced into the crack by putting a pressure on the solution. This is sometimes done by means of a tire pump or bicycle pump.

Another method of repairing a short crack consists in applying an iron plate about 1-8 inch thick. Before putting on the plate drill a small hole at each end of the crack, then cut a V-shaped groove along the crack from end to end. Then

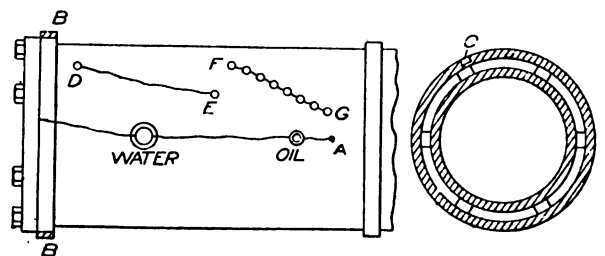

Cracked Cylinder Jacket and Suggested Repair.

in the groove put a packing of thin asbestos wick soaked in white lead paste, after which a packing of sheet asbestos the size of the plate and dipped in water is placed over the surface to be covered by the plate. The plate is put on with small screws (about 1-4 inch). The screws should be about 1 inch apart and about 1 inch on each side of the crack. If the jacket is so thin that it is necessary to drill through, then the screw heads should be packed with hemp or asbestos soaked in white lead paste.

## SMALL INVENTORS MAKE ANNUAL SHOWING

By W. F. BRADLEY.

PARIS, April 9.—Original and useful ideas of value to the automobile industry are as capable of being produced by humble workers as by persons in outstanding positions, declared a Paris newspaper, and to encourage the introduction of such works it formed a small inventors' exhibition to be held annually.

The fourth event, though more pretentiously installed than its predecessors, is hardly as strong in inventive value, and when the patent collar button, fountain pens, and other automobile novelties have been removed, there is only a small selection.

To prevent a light-fingered gentleman cranking up a car and driving away with it while the owner is temporarily absent has more than once been the object of a competition in France. One invention of this nature shown at the exhibition consists in attaching a locking cage to one of the cross members or side frame and passing through it a squared section of one of the brake connections. When the brake is put hard on a combination keyway on the squared section corresponds with a combination on the locking cage, allowing a pin to be dropped through and turned round so that

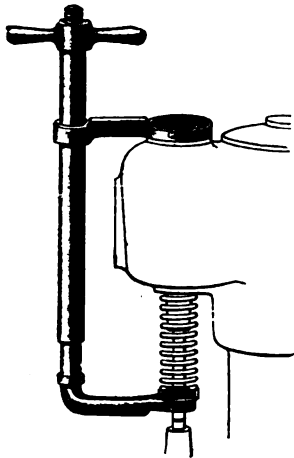

New Valve Remover

it cannot be withdrawn unless the combination is known. The principle is one that has been applied with a considerable amount of success to keyless locks. A marked collar above the locking cage allows of several combinations being made.

Allowing an automobile to smoke is an offense in most French towns. To keep drivers out of the hands of the police, therefore, an inventor runs the lubricating oil into a float chamber similar in principle to that of a carbureter. A needle adjustment allows of regulating the height of the float. Thus, only a determined amount of oil can pass through feed to engine.

### Two Inventors' Ideas of Mechanical Self Starters.

Mechanical self starters were but two in number. On one a coil spring mechanically wound up by the motor, was contained within a metal casing mounted in the usual position of the starting handle. By the release of a lever on the dashboard, the internal spring was disconnected, allowing the box to revolve rapidly on its shaft and at the same time engage with the forward extension of the crankshaft, thus rapidly turning over the motor. When the engine started up it would overrun the apparatus, then rewind it ready for future use. Owing to the absence of competent attendants, it was impossible to see what device had been adopted to obtain rewinding.

In the second invention a small aluminum case in front of the engine provided two fingers to engage with a steel pin traversing the end of the crankshaft. Normally the fingers were contained on a sleeve within the case and were only brought out to engage with the crankshaft on the drawing over of a side lever, which also, by a reciprocating motion, caused the sleeve and fingers to revolve together, carrying with them the engine. When the motor overran the starter, the fingers only being held out by coil springs were pushed back into their sleeve until withdrawn by placing the lever in neutral position.

Valve removal is simplified by an instrument known as the Palita, which fits one arm over the compression cock or the base of the plug and inserts a lower one with forked end under the base of the valve spring. A few turns of a screw and the lower arm is raised and the valve spring compressed. The device is a

simple one, but is obviously limited to use on an engine with valves in pockets.

A radiator without radiating tubes was formed by a tank divided by horizontal divisions into three distinct compartments. In the top one was contained the hot water coming from the engine; the center one was an air tank, and the lower one received the cooled water by means of a couple of connecting pipes. By means of an air pump driven off the engine shaft by belt and pulley, a strong current of air was sent into the central chamber and through a serpentine pipe passing through the hot water compartment and outletting at the head of the tank.

An air-cooled spark plug sounds anomalous, yet this is what was shown on one stand. The porcelain was baked with a number of holes passing down from the head and coming out immediately above the metal cup of the plug. By thus exposing a greater surface to the air, heat would be more readily carried off and less risk incurred of cracked porcelain.

An extensible pulley for belt transmission on light cars consisted of two pairs of metallic discs mounted on separate shafts, one of each being fixed, the other being keyed so as to give a slight lateral movement. On the inner face of each disc was an extensible pulley formed by six metallic sections, each one of which was connected by an arm passing through a slot in the disc to a sleeve on the pulley shaft. Thus, as the sleeve was pulled towards the disc the segments forming the pulley would be moved farther towards the circumference, forming a larger but broken pulley.

### Two Attempts to Improve Heavy Road Wheels.

Though patent road wheels have always been an enticing field for inventors, only two were shown at the exhibition. A solid rubber tire was shod with a series of metal plates or shoes, each one being held by a pin passing through rubber and felloe so as to allow a slight pivoting movement. Each bolt was threaded to allow of regulating the normal pressure on the rubber bandage. Instead of the rubber coming in contact with the road, the chain of metal shoes took the road wear and by their pivoting arrangement allowed compression and expansion of bandage.

A dismountable, extensible road wheel for commercial vehicles, providing for changing of rims, consisted of a forged steel hub with fixed collar, on which were mounted, in the form of a double cone, tangential wooden spokes. Each spoke lodged in a suitable assembling plate on the hub, and in a steel socket on the inner face of the felloe. By screwing up at the hub the

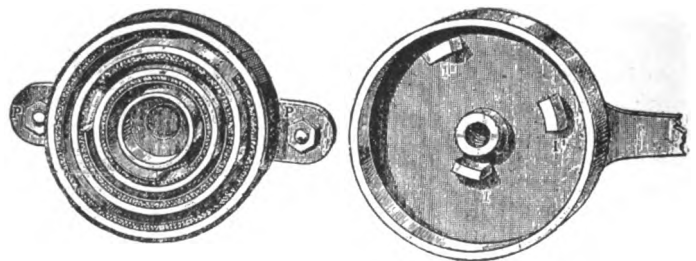

Working Parts of New Type of Shock Absorber.

split felloe was expanded until it bound tightly the steel rim. The hub cap acted as a locking nut and a double wedge inserted in the opening on the felloe prevented further traction.

A very simple type of shock absorber was formed by a circular metallic case containing three projecting rings, one within the other, each one fitted with a leather-faced ring of spring steel. Three projecting studs on the cover of the case engaged progressively between the spring and the crown, thus giving three increasing ranges of compression and resistance as the cover revolves. A pivoting connection linked up the arm of the shock absorber with the spring seating in the usual manner.

## LETTERS INTERESTING AND INSTRUCTIVE

### ABOUT TESTING THE LUBRICATING OILS.

Editor THE AUTOMOBILE:

[1,307.]—Is there any test by which a good lubricating oil can be differentiated from a bad one, without actually trying them all on my machine? Is there anything in this "Color Test for Carbon" that I have seen advertised? It is claimed that the light-colored oils contain less carbon than dark-colored oils. A. RAFELSON.

New York City.

The chief essentials of a good lubricating oil are freedom from acid, and, where intended to be used in the motor itself, a sufficiently high flash point. To test oil for the first quality, take a piece of bright machinery steel and a short strip of cotton wicking. Soak the latter in the oil to be tested and wrap it around the bright metal. Place it where the sun will shine on it and allow it to remain there for some days. If the oil undergoing the test is absolutely free from acid, there will be no indication of etching on the steel, no matter how long the test may be extended, but even a comparatively small percentage will make its presence known at the end of a week or so.

In order to ascertain the flash point of an oil, heat a sample of it over a Bunsen burner, or on a gas stove, placing a thermometer in it so that the bulb does not come in contact with the wall, or bottom, of the containing vessel. When the oil begins to vaporize, take a lighted taper and pass it back and forth through the vapor. When its flash point is reached, the vapor will ignite in short blue flashes, but it will not continue to burn, nor will the oil itself take fire. The temperature at which this occurs is its flash point, and for automobile cylinder oil it should be quite high. We have never had any experience with the so-called "color test."

### ANOTHER WAY OF REPAIRING A JACKET.

Editor THE AUTOMOBILE:

[1,308.]—Being a subscriber to "The Automobile," I write to ask how to repair the water jacket on a gasoline engine cylinder having a portion broken out. I have been told there is a way they are repaired with a piece of copper, without using any bolts or clamps. G. I. THEW.

Osseo, Wis.

The method you refer to is known as "calking," and consists of filling the opening in much the same manner as a seam in a ship is calked. Take a piece of soft copper, preferably copper wire, slightly larger than the crack to be closed, and force it into the latter. The idea is to fill the opening as closely as the original material did, and, as soft copper is very ductile, it may be forced into intimate contact with every variation of the surfaces of the fissure. The opening should be cleaned out first, and, if possible, its interior made slightly larger than at the surface with a file, thus permitting of a rivet fastening, the amount of copper in the crack being greater than that at the opening. A file, hammer and cold chisel are about the only tools required, and as the jacket is not subjected to much pressure, it is not difficult to make a joint that will not leak.

### SOLDER AND FLUX FOR ALUMINUM.

Editor THE AUTOMOBILE:

[1,309.]—Please advise me if there is anything for immediate use in the shape of solder for aluminum ware, or if there is a flux that can be used with common solder for this purpose? Will you please let me know if I can obtain this anywhere?

West Liberty, Ia.

LOUIS K. NICHOLS.

There are numerous formulæ for solder and fluxes to be used on aluminum given in various works, but usually they call for the materials not readily procurable in small places, and the method of preparing them is not always possible to the worker with average facilities, so that you will find it much better to buy solder of this kind, which is now on the market. You will find the announcements of manufacturers of aluminum solder in our advertising columns.

### IS CAST STEEL A GOOD AXLE MATERIAL?

Editor THE AUTOMOBILE:

[1,310.]—Will you please let me know whether cast steel can be used for the front axles of an automobile, the axles to be cast hollow? Also, whether any manufacturer is at present using cast steel for that purpose. O. M. BOSART.

Indianapolis, Ind.

We hardly think it is a particularly suitable material, whether cast hollow or solid, and do not believe that any American manufacturers are putting out cars with cast-steel front axles. However, as the tensile strength of good cast steel will run as high as 50,000 pounds to the square inch, with an elastic limit of 30,000 pounds, it might do for low-priced and low-powered cars. These are not maximum figures by any means, as cast steel has been produced with a tensile strength as high as 84,000 pounds, and an elongation of 15.6 per cent. It seems, however, that silicon is a requisite to making successful steel castings, and as one of the prime requirements of an automobile axle is "shock ability," or capacity to resist dynamic stresses, great care would have to be taken to keep this element, as well as the phosphorus, as low as possible in order to avoid brittleness. We have heard tales to the effect that motors have been discovered with cast-iron connecting rods, so it is quite possible that cast-steel axles have been employed. Steel castings have been very largely used for heavy marine work. If any of our readers can throw any more light on the subject, we should be pleased to hear from them.

### LOOK FOR AN INTERMITTENT SHORT-CIRCUIT.

Editor THE AUTOMOBILE:

[1,311.]—Should the coil vibrate when the terminal is disconnected from the spark plug? On my Reo runabout, when the engine is turned over with the terminal disconnected, the coil vibrates. I can find nothing wrong with the wires. By adjusting the timer so as not to have any vibration with the terminal disconnected, on connecting the terminal without readjusting the timer, there is no spark. The engine seems to run as well as when I first got it, but I do not know whether the ignition system acted in this way originally, or not. W. E. SHARKEY.

Middletown, O.

Judging from the description of the trouble given, there would appear to be an intermittent short-circuit in the timer. That is, it only occurs when the latter gets in a certain position. There may be sufficient strain on the wire leading from the timer to the plug to prevent its occurrence when the two are connected up, and taking the terminal from the plug would relieve this and allow it to make contact. This seems to be the case, in view of the fact that you state the wiring to be in good order throughout. No ignition system should be in this condition. The coil should only vibrate when contact is made at the timer as intended.

### ABOUT IMPROVING AN OLD MODEL CAR.

Editor THE AUTOMOBILE:

[1,312.]—Will you kindly give me some advice as to what to do with an automobile? I have a Model A Cadillac, single-cylinder, 10-horsepower car. The compression of the motor is not good. There are three piston rings, and I put on two new rings, the middle one being allowed to remain as it did not appear to be much worn. I noticed that the grooves in the piston were more worn than the rings. The new rings made the compression a little better, but not what it should be. Should I have put on three new rings? Is there anything I can put in the cylinder to improve the compression, yet not interfere with the spark plugs? I use grade A Mobiloil. Is that right for such a motor? I also have trouble with the motor popping some times, when starting. It generally runs all right on low speed, but when I throw the lever into the high speed, the motor starts popping as though the spark advance lever was advanced too much. I am sure the spark is not set too early. I also have trouble with the clutch disk slipping, and am compelled to use rosin, as the leather on the disk becomes smooth. Is that right, or do you know of something



better? The motor makes considerable noise when running in slow speed; apparently in the transmission gear, though an examination showed it to be all right.

R. H. HARRINGTON.

Newcastle, Del.

In replacing the piston rings, three new rings should have been put on. The fact that the grooves show wear is evidence that the motor has been run for a long while after the piston rings had lost their effectiveness. If the use of three new compression rings does not restore matters almost to their normal condition, probably a new piston will be the only remedy. Any other method of increasing the compression could only be a makeshift—that is, such expedients as placing an iron plate on the head of the piston and the like. Examination of the piston may show it to be possible to turn new grooves in it, requiring a slightly wider piston ring, in consequence, and, next to a new piston itself, this is doubtless your best remedy.

Most refiners recommend certain of their brands for use on certain makes and models of cars, and you will seldom go wrong in following their advice. We cannot state definitely whether the brand of oil in question is the best for your car, and, except by making experiments, the only way of finding this out is to apply to the builder of the car. Popping in the carbureter is usually due to a weak mixture which continues burning in the cylinder throughout the exhaust stroke and until the inlet reopens, the escape of the gases still under pressure being responsible for the noise.

We do not find your statement, "popping as though the spark advance lever was advanced too much," entirely clear. Do you mean an actual popping, *i. e.*, like a slight explosion of gas in the open air, or a knock? It would appear to be the latter, from your description, especially when taken in connection with the condition of the other parts of the motor. This would result from a loose big-end, or wrist-pin, bearing, and always makes itself manifest when the load is applied. The fact that it runs fairly well at all times is merely evidence that it is being run under conditions sufficiently favorable to call for but a fraction of the motor's power to propel the car. The noise from the change speed gear is only an indication of its worn condition. The planetary type is far from being noiseless, even at its best, when run on the low speed. There is no remedy that we know of, except a new gear set, which would be an expensive repair. Filling the gearcase with "dope," or heavy grease, may suffice to stifle the noise to a certain extent, but it imposes an added resistance on the gear, and is usually not recommended by manufacturers, though very generally practised by repairmen. Probably the high-speed clutch may need adjustment, bringing its faces closer together, or a new leather facing, or both. Soaking the new leather disc in neatsfoot oil, before applying it, will prevent its drying out and becoming polished, through the lack of proper adjustment is doubtless responsible for the latter, as the leather is only held against the metal with sufficient force to grip when the load is light; the rest of the time it is the same as if it were being pushed against a polishing wheel.

### BALANCING A TWO-CYLINDER ENGINE.

Editor THE AUTOMOBILE:

[1,313.]—Will you please inform me if my four-horsepower, two-cylinder engine should be balanced? The piston, wristpin and connecting rod weigh 10 pounds. Would it be just as well to bore four 2-inch holes through the balance wheel to take out 10 pounds? The balance wheel is 3 inches thick. Will the engine run any better if I balance it this way, or is it just as well to let it be the way it is?

H. E. COVILL.

New Bedford, Mass.

By all means, let the engine remain as it is, as the expedient you mention would hardly tend to improve its running any. It is to be presumed that the designer of the engine provided for balancing as well as could be done with the particular type that it happens to be, and there is not only nothing to be gained by attempting such a makeshift as you propose, but it would, in all probability, end by ruining the engine. There certainly does not appear to be anything to be gained by such an expedient.

### UNIQUE EXPERIENCE WITH A FRANKLIN.

Editor THE AUTOMOBILE:

[1,314.]—An experience that I had recently in driving my Franklin may be of interest to your readers, as constituting a striking illustration of what an automobile will sometimes go through without suffering anything more than merely nominal damage. I was running over a piece of road that had just been repaired, and was very rough. While going at a pretty good pace my hat blew off, and I made a grab for it instinctively. Just as I did so the front wheel struck a boulder and the right side pair of wheels went into a ditch about 18 inches deep. At the same time a small boy ran out in the road directly in the path of the machine. I make a quick swerve to escape the boy, but as the right side of the car was 18 inches lower than the left, the whole car "turned turtle."

Fortunately for me, I landed on my feet and escaped without so much as a scratch. The engine continued to run undisturbed until I crawled under the car and opened the switch. With the assistance of three boys, ranging from 12 to 15 years old, I righted the car, picked up the cushions and tools, straightened the steering gear a bit, and ran the machine home. The only damage to the car was the bending of the hood, mudguards and the brass spokes of the steering wheel. A few hours' work remedied things.

Dania, Fla.

JOHN W. MULLIKIN.

### VALUABLE HINTS FOR FORD OWNERS.

Editor THE AUTOMOBILE:

[1,315.]—Referring to your column "Letters Interesting and Instructive" and to the letter of F. R. Ziegler (No. 1,217), in your March 12 issue, and to No. 1,277, in your issue of March 26, regarding trouble which these gentlemen have experienced with Ford runabouts. The writer had the same difficulty, and the local agent for the Ford assisted me. If the following is of any benefit to these gentlemen, it may be worthy of space in your interesting columns.

The gasoline supply pipe runs near the exhaust pipe for several inches in front of the gasoline tank, in the Ford runabout. After the engine has run for some time the heat from the exhaust pipe becomes sufficient to vaporize the gasoline in the supply pipe before it reaches the carbureter. The trouble is one that is baffling because a short stop is all that is required to permit the cool gasoline from the tank to sufficiently lower the temperature in the small feed pipe to permit liquid gasoline to flow to the carbureter again. Hence, any alteration in the carbureter or ignition or any other part of the car which occupies a few seconds is apparently all that is needed to cause the engine to start again. If these parties will bend the gasoline pipe away from the exhaust pipe and wrap that portion of the exhaust pipe coming nearest the gasoline supply pipe with asbestos, they will probably overcome the difficulty.

PAUL A. DINSMOOR.

Lawrence, Kan.

### MR. HAZLETON CITES FACTS AGAINST HIS CRITIC.

Editor THE AUTOMOBILE:

[1,316.]—Referring to Mr. Woolston's statement in the March 26 issue, he thinks 25 pounds of water cannot be vaporized with one pound of kerosene. I made experiments at Nevada and San Francisco, Cal., on both coal and crude oil, and in both cases I could vaporize double the water with oil that I could do with coal. I sold the Atlas Engine Company two 700-horsepower Hazelton boilers, with a guarantee to do 12 pounds with one pound of combustible, and putting the water in boilers from a heater that raised the feed water 2 to 12 degrees, with 100 pounds on boiler. I fulfilled my contract. If kerosene is as valuable as the California crude oil, and it should be better, I can vaporize 25 pounds with one pound of oil. I will use kerosene on my first auto, as I expect to run it to Chicago. Later will try coal.

M. W. HAZELTON.

Oneonta, N. Y.

### A HELPFUL SUGGESTION FOR NUMBER 1,218.

Editor THE AUTOMOBILE:

[1,317.]—Have just read letter No. 1,218, and would suggest that the trouble may be in the timer; that is, it may not make contact at the right time. To-day I had trouble very much like this, and while it was not in the timer itself, I found it in the coil—Splitdorf—the connection between the different units being broken and almost every time I started the motor it would fire back through the carbureter.

C. R. HASTINGS.

San Francisco, Cal.

### CAMERON ALSO MADE FOR SOUTHERN TREAD.

Editor THE AUTOMOBILE:

[1,318.]—We notice, in one of your late editions, a letter from one of your readers relative to the supplying of a 60-inch tread on cars for use in the South. We wish to state that we supply the 60-inch tread on all of our four models, when specified.

CAMERON CAR COMPANY,

Beverly, Mass.

H. W. Doherty.

## COMPARE MAINTENANCE WITH OTHER TRANSPORTATION

BY H. O. SMITH, TREASURER AMERICAN MOTOR CAR MANUFACTURERS' ASSOCIATION

WHAT has been done in automobile manufacturing is only a repetition of history as it relates to other commodities which America has been attracted to and has taken up to develop. The American has proven himself capable of quickly grasping the situation and foreseeing the future possibilities.

It would be difficult to fully realize that from so humble a beginning, and with seemingly so little that is practical to build on, an industry would develop in less than ten years to the enormous proportions of the automobile industry to-day. It promises to continue to expand, and, at the present rate, will in a very few years assume such magnitude that it will be equal to our most important and thriving industries.

A few years ago the belief was general that the automobile would not prove a practical conveyance. One basis on which this opinion seemed to be founded was the fact that our roads had not reached the same standard as European roads, and it was not generally believed that even the most able engineers could design and build a road locomotive to be placed in the hands of inexperienced drivers and used successfully on the roads as we find them, and especially when machinery like that of the railway locomotive was not subjected to rigid expert supervision.

A casual observance of the motor cars in use, supported by the figures, shows that the volume of business done in 1907 represents more than \$100,000,000. This unquestionably proves that the motor car is, and must have been for some time, taken seriously, and that it is no longer considered a luxury or a fad, but is very properly regarded as a practical, economical and dependable conveyance.

A close observer will note that among the standard makes of cars there have been but few radical changes in the last two or three years. It is safe to say that such changes as may characterize the succeeding years' models for some time will be only in the nature of minor changes or improvements and possible body design. It is quite probable that the foremost products of the day will not be considered *passé* several years hence, and for this reason the purchaser of a motor car will not necessarily feel that it is important to sacrifice a car which has seen but one season's service. It is possible for the casual observer in looking over a motor car to appreciate what the automobile of to-day really represents. It is not only a self-contained power plant, refined to a degree of simplicity which makes it possible for those who are inexperienced in mechanics and the handling of machinery to successfully operate a car, but, in addition, the car represents the carrying conveyance itself.

Compare this for a moment with the locomotive which is seldom permitted to travel 200 miles even in the hands of skilled engineers before it is thoroughly inspected and overhauled, notwithstanding the fact that it has not been forced to encounter irregularities in road surface or excessive grades, all of which evidences the fact that careful thought and research are necessarily behind the designing, developing and producing a satisfactory automobile.

It is necessary that a successful builder of motor cars be an able mechanical engineer, but, more than this, he must also be capable of determining necessary sizes and dimensions, and so designing each part as to make it most efficient in service, and of determining those metals which are least affected by the strains and vibrations. It is necessary that anti-fatigue metals be used throughout to avoid the tendency towards crystallization, and, in addition to all these, he must possess a large experience with the motor cars in actual service to best determine the peculiar requirements of the various parts of a motor car when in actual service. We have not only developed the automobile in this country, but we have developed the engineers. The question is often asked: What is the life of the motor car? It would be quite as appropriate to ask how long the engine in a power plant would last. As a matter of course, in either instance the article must be well designed, of proper proportion representing good workmanship and material, and adapted to the service required of it. These requirements being met, the life of the automobile depends upon the care given it. If it is kept properly lubricated and adjusted (which does not mean dismounting and reassembling frequently), the life should be indefinite, except the occasional refitting of certain bearings and minor parts. With actual records of many cars being from 30,000 to 50,000 miles, and all seemingly in good running condition, it is evident that the life of the automobile is not limited.

The future of the motor car depends entirely upon the way it compares with any other means of transportation: first cost, maintenance, and results considered. It is safe to say that a standard well made car of medium size can be driven an average of 30 miles a day, or 900 miles a month, at a cost for fuel, including oil and gasoline, of from fifteen to twenty-five dollars per month. Records can be produced showing that with reasonable care the cost of maintenance, aside from the items mentioned, mishaps, and tire renewals, is from \$25 to \$50 a year. Compare these figures, which are not necessarily the most conservative, with any other means of transportation, and the real worth of an automobile can be obtained.

## SEE NO IMMEDIATE FUTURE FOR THE ALCOHOL MOTOR

SYRACUSE, N. Y., April 13.—Extensive experiments have been carried on with the alcohol motor in the laboratories at the Franklin auto factory. The results obtained equal the results obtained in France and also the results obtained by Professor Lucks at Columbia University. The Franklin people, however, conclude that the results do not warrant the belief that there will be an immediate demand for the alcohol motor. But the Franklin people do not consider that they have finished the work and are continuing the experiments. Results to date show that even if alcohol and gasoline could be purchased at the same price per gallon, the gasoline motor would be the more economical. In other words, with the two fuels at the same price it would be cheaper to use gasoline. This is because there is a great deal more energy in a given amount of gasoline than there is in a given amount of alcohol, and up to date there is no way known by which the handicap can be overcome.

There is another very serious drawback to the use of alcohol as against the use of gasoline, say the Franklin experts. The motor can use practically any amount and not suffer. In the gasoline motor, the "mixture" must be right or the motor does not work well. If the gasoline is used too freely and the "mixture" becomes too rich, the operator knows it at once by the loss of power, etc. This is not true with alcohol. For example: If the alcohol motor was running at the rate of three miles to one gallon of alcohol and some little change in the adjustment or conditions caused the alcohol to be fed faster, the motor might consume a gallon to a mile and the operator would not know it. Therefore, under all conditions known to-day the Franklin people conclude that there is no immediate future for the alcohol motor, but they do believe that it is of sufficient importance to merit further experimenting with the possibility that the problem can finally be solved.

# THE AUTOMOBILE THAT I DREAM OF THESE DAYS\*

By HENRI FARMAN.

SOMEbody asked me the other day if I had completely renounced the automobile, and if I had definitely abandoned the course for the domain of the air. The fact is that the numerous forms of work to which I have to devote myself, the multitudinous and incessant cares which are involved in the con-

struction and surveillance of apparatus, which, it must be admitted, is still in its infancy, have scarcely allowed me time to think of anything else. Flight is a thing so novel, and the sensations that spring from gliding above the surface are so totally different from anything anticipated, that you will readily understand, that any one who has once tried them can hardly think of anything else but a repetition of the experience. But I cannot forget the road course altogether—the scene upon which I made my debut in the world of sport, and which, by a curious coincidence, led me through the very capital of Auvergne, above which we must fly, sooner or later, in order to gain the prize offered—another coincidence—by the generosity of Michelin. I cannot forget that it was in the Paris-Berlin, in the Paris-Vienna, and in the Paris-Madrid, that I acquired the habit of flying that enabled me to maneuver my aeroplane above the drill ground at Issy-les-Molineux. But my already numerous trials have shown me what can be obtained from an aerial propeller. One seldom thinks of the air as a supporting material, and many doubt the assertion that the air is almost as solid as the surface of our roads, when one knows how to make it serve his purposes. However, many interesting experiments have already been made on that subject.

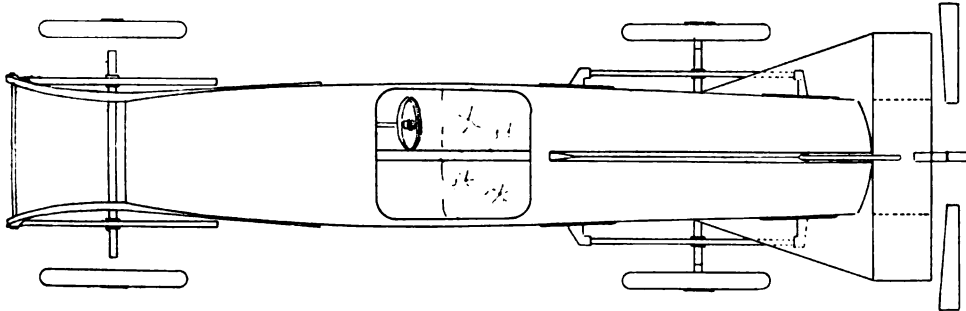

The Wings, Even With Limited Area, Will Decrease the Car's Weight.

struction and surveillance of apparatus, which, it must be admitted, is still in its infancy, have scarcely allowed me time to think of anything else. Flight is a thing so novel, and the sensations that spring from gliding above the surface are so totally different from anything anticipated, that you will readily understand, that any one who has once tried them can hardly think of anything else but a repetition of the experience.

But I cannot forget the road course altogether—the scene upon which I made my debut in the world of sport, and which, by a curious coincidence, led me through the very capital of Auvergne, above which we must fly, sooner or later, in order to gain the prize offered—another coincidence—by the generosity of Michelin. I cannot forget that it was in the Paris-Berlin, in the Paris-Vienna, and in the Paris-Madrid, that I acquired the habit of flying that enabled me to maneuver my aeroplane above the drill ground at Issy-les-Molineux. But my already numerous trials have shown me what can be obtained from an aerial propeller. One seldom thinks of the air as a supporting material, and many doubt the assertion that the air is almost as solid as the surface of our roads, when one knows how to make it serve his purposes. However, many interesting experiments have already been made on that subject.

It will be recalled that as early as 1906, Archdeacon experimented with a motorcycle with an aerial propeller placed forward. That machine, with the screw propeller turned by a 6-horsepower motor, was tried out at Acheres. Driven by Anzani, it attained a speed of 79 kilometers 500 meters an hour, a

\*Translated from *La Vie au Grand Air*, by Charles B. Hayward.

speed practically equal to what it would have been capable of had the power been applied to the rear wheels, although the propeller was completely demolished by an accident. On an automobile, the results will be even better, and particularly on bad ground, for then, with the increasing speed it will frequently happen that the wheels will leave the ground and this friction will be eliminated, thus avoiding a serious waste of power. Since the time in question, screw propellers have been perfected. A propeller easily has an efficiency of 50 per cent., delivering half the power of the motor, while the best automobiles scarcely do better than 75 per cent., counting the power delivered at the rear wheels. But that is not their true rating by any means, as account must be taken of the tremendous losses, due to the slipping of the wheels on the road surface,

this being the greatest evil to be contended against in this method of transmitting the power. With a propeller, on the contrary, the transmission is superb, as the effort is constant, while with wheels it is intermittent and jerky.

If, then, I ever return to the road course, it will not be on an ordinary racing car, but one constructed according to the plans which I will outline to you. The car will be composed solely of two axles, the motor, and the screw propeller, the illustrations reproduced here being the result of collaboration with the Voisin brothers. It will have no clutch and no differential. Stripped of all the complications customary on ordinary cars, it will consequently be very light, and should not exceed 400 kilos. With a 50-horsepower motor and a screw propeller 1 meter 80 in diameter, I estimate that it should be capable of at least 150 kilometers an hour. Its form will be very much tapered, in order to diminish the resistance of the air. It will be provided with flat wings, and, even with a reduced area, these wings will be capable, at a speed of 100 kilometers an hour, of relieving the car at least 200 kilos of its weight, so it will be very easy on pneumatics. I have, moreover, a certain criterion to judge by, and that is that my aeroplane, while over the training ground at Issy, is faster than cars of the same power. I thus believe I am right in affirming that my car with its aerial propeller will be faster than a car of any other type, of the same power. Certain it is, that it will be by far the simplest thing on wheels that will have the power to make this speed, and its coming will doubtless make a revolution in racing design.

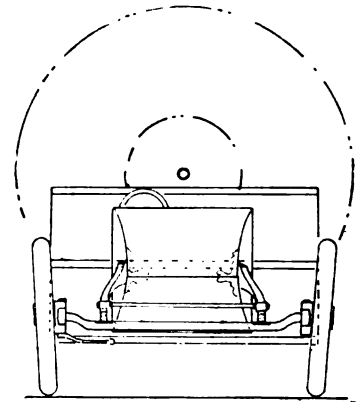

Area of Aerial Propeller.

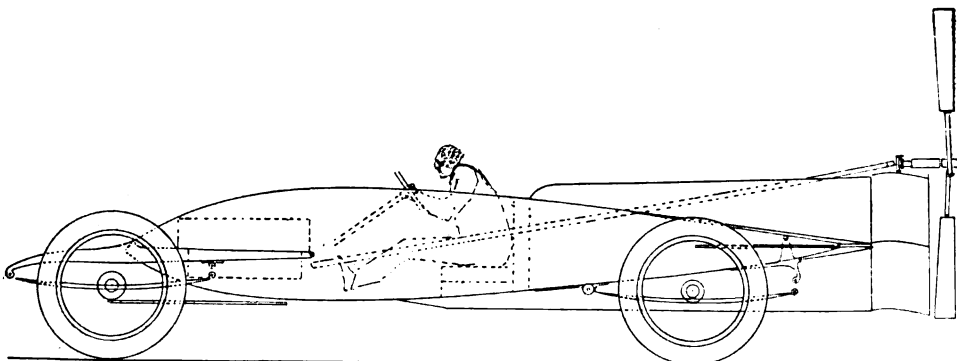

This Car, Weighing About 400 Kilos., Should Make 150 Kilometers per Hour.

But will it ever see the light?

**CONCERNING THE EARL.**

While the expansion of the motor buggy field in the Middle West was having new converts daily through the steadily increasing numbers of friction-driven cars, a new concern, the Earl Motor Car Company, was locating in Kenosha, Ill., and manufacturing on a medium scale friction-driven cars of the two-cylinder type and employing that conventional disc-and-wheel transmission system, although using new methods of engaging these friction members. The car then marketed was a 16-horsepower design with an opposed motor in front and the transmission located midway between the motor and rear axle, permitting of the use of reasonably short side chains for transmitting to the rear wheel. Since then the company has climbed one round higher in the ladder of automobile manufacture by bringing out a larger 20-horsepower two-cylinder car and a four-cylinder roadster for the present season, the manufacture of

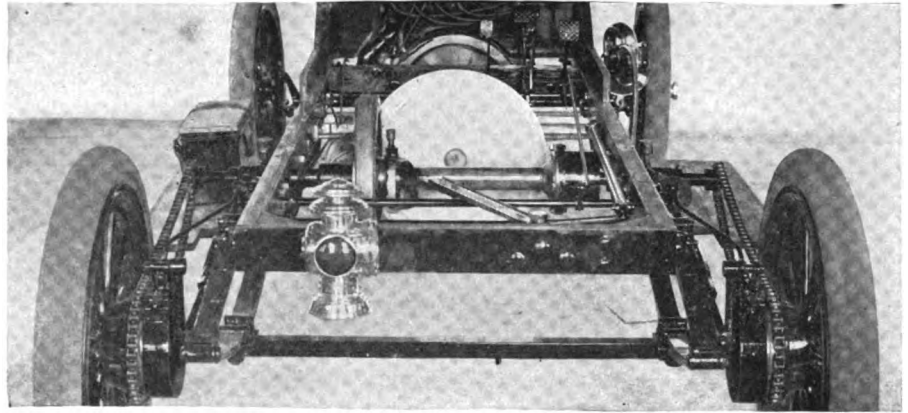

Rear View of Chassis of Earl Friction Drive Car.

pedal, whose connections are illustrated herewith, is used, and by means of which the disc is locked by the ratchet in its disengaged position, the coil spring at this time being under greater compression. Should, however, the spring not give sufficient engagement then the left pedal is used to assist in forcing the disc against the wheel to increase the pressure.

The much talked of slip between the disc and wheel is not looked upon as sufficient excuse for a differential, and consequently fitted to the right end of the cross-shaft is a spur-gearred differential.

Conspicuous in the running-gear of the Earl roadster is the employment of a wooden chassis frame, the sills being reinforced by steel plates 3 1-2 inches wide and taken from 3-16-inch stock. Spring suspension throughout is by full elliptics, the driving strain of the rear axle being absorbed by a pair of turn buckle radius rods, extending between the axle and the jackshaft. Braking effort rests with a pair of band brakes on the rear wheel, to which can be added the action of the friction-driven reverse when occasion demands it.

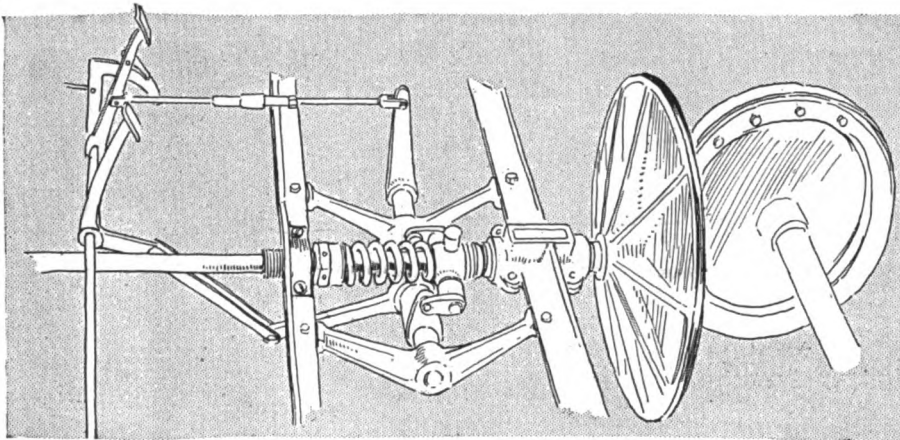

Detailed Outline Sketch of Earl Friction Drive Mechanism.

which now occupies the major energies of the Kenosha plant.

The style of transmission used in the two and four-cylinder cars is alike and central picture illustrates its general design. At the rear face of the flywheel is a universal joint, and a longitudinal driveshaft, which at its forward end is a sliding fit within this joint, carries on its rear end the radially-ribbed friction disc shown in the illustration and which contacts with sliding friction wheel of the regulation type on a rigid cross-shaft. The friction disc with its longitudinal shaft slides endwise for engagement with the friction wheel and disengagement therefrom, but the novelty in connection with this is that a heavy helical spring keeps the disc constantly pressed against the friction wheel, the same as a clutch spring keeps the clutch engaged except when released by the driver by pressure on the clutch pedal. Should this spring, due to any cause, not give sufficient contact between the disc and wheel, pressure on a pedal may be used to augment such engagement. The reader will at once recognize the difference between this friction scheme of constant engagement and that generally used; the general scheme being to keep the disc and wheel separated normally and bring them together by ratchet retained pedal, thereby depending solely on mechanical means for engagement.

Used in this car is a 22-horsepower Waukesha motor, characterized by 4 by 4-inch cylinders, both sets of valves carried in chambers on the left side, a jump spark ignition with one set of plugs carried, not in the valve caps, but in the angle between the intake and cross valve and the cylinder dome. Cooling and lubrication are patterned after the regulation types endorsed by standard engineering practice, and in fact this is true of the remainder of the car.

In disengaging the disc and wheel, the control, consisting of the ratchet-retained

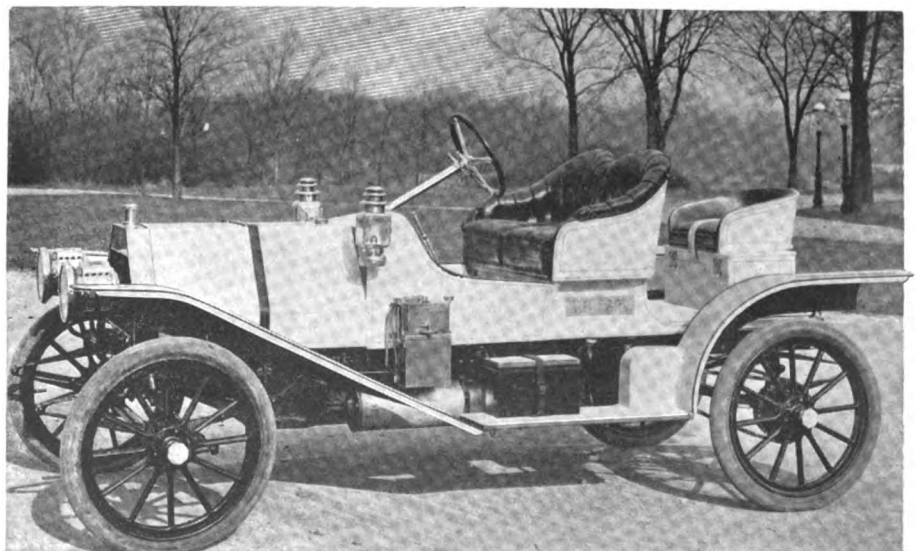

Earl Four-cylinder Roadster—a Newcomer This Season.



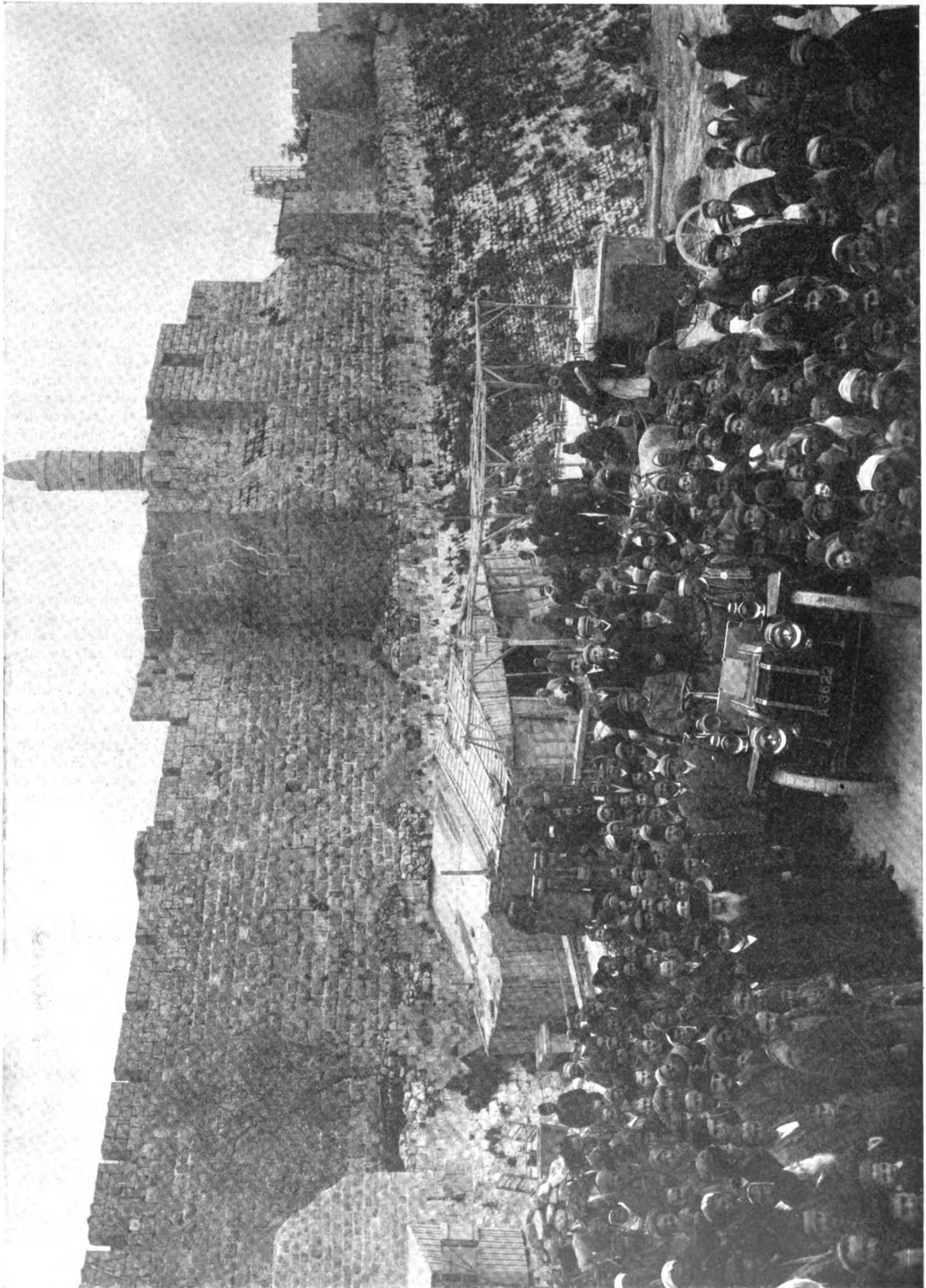

The Array of Jerusalem's Denizens that Greeted Mr. and Mrs. Charles J. Glidden, on March 13, on Their Arrival at David's Tower, Jaffa Gate.



**THE GLIDDENS IN THE HOLY LAND.**

Hitherto the official successors of Mahomet have positively declined to issue firmans permitting an automobile to traverse the Holy Land, and it remained for Globe Girdler Charles J. Glidden to so ingratiate himself into the Sultan's favor that he was the first automobilist to be honored with the official permit. As noted in THE AUTOMOBILE of April 2, Mr. and Mrs. Glidden landed their car at Haifa, going thence to Jaffa and Jerusalem. Later advices state that they have completed the tour of the Holy Land, driving in all a total of 500 miles in that world-famed region.

Their arrival at the Jaffa gate of the Holy City was the signal for much excitement among the natives. A great crowd collected to bid them welcome, and foremost among those to extend greetings were the American Consul, the Hon. T. R. Wallace, and Mrs. Wallace, who, with their young son, are seated in the car with Mr. and Mrs. Glidden, in the photograph on the opposite page. After leaving Jerusalem the tourists proceeded to Hebron, thence to Jericho, and along the River Jordan to the Dead Sea, and returning visited the Mount of Olives, and thence to the port of Haifa, via Nablus.

According to Mr. Glidden a carriage with high clearance is necessary to successfully negotiate the roads of the Holy Land, which are stony and sometimes have muddy grades up to twenty per cent. His total world's tour mileage up to March 19 is 43,367 in thirty-seven countries traveled, and he has been on the road a total of 350 days.

**NANTUCKET'S FIGHT TO BE AUTOLESS.**

BOSTON, April 11.—The island-county-town of Nantucket, in Massachusetts, which has waged war on the automobile ever since that type of vehicle became sufficiently perfected to venture so far at sea as Nantucket, has scored an important point in its campaign of exclusion. A week ago the island authorities invited the legislative committee on Roads and Bridges to visit the island and look over the possibilities of the use of its narrow, cobble-paved town streets, and its one good piece of State road for automobiles. The committee spent a day or so at the island, and when it returned was so well satisfied with what it saw that it has reported a bill exempting Nantucket from the working of the general automobile law for three months of the year.

For several years Nantucket has tried to exclude automobiles under the general law, but it has not been altogether successful and automobiles have actually invaded the streets held sacred during the summer boarder season to the livery stable surrey. Under the bill reported this week, however, it is provided that the part of the law which permits of review of local regulations by the Highway Commission shall not apply to Nantucket from June 15 to September 15. As this is the only time anybody wants to go to Nantucket the bill amounts to exclusion.

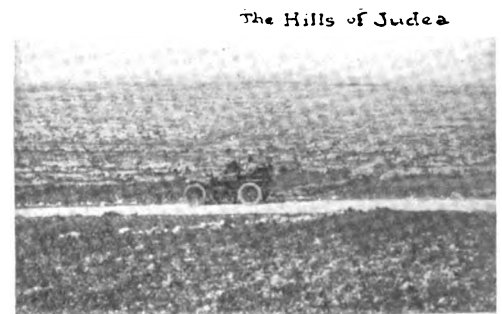

## THE AUTOMOBILE CALENDAR.

## AMERICAN.

## Shows and Meetings.

- Apr. 21-23.....—Louisville, Ky., New Coliseum, Automobile Show. Hubert Levy, manager.
- June 25-27.....—Detroit, Third Annual Summer Meeting of Society of Automobile Engineers.
- January, 1909...—New York City, Madison Square Garden, Ninth Annual National Show of the Association of Licensed Automobile Manufacturers. (Exact date to be announced.)
- February, 1909.—Chicago, Coliseum and First Regiment Armory, Eighth Annual National Exhibition, National Association of Automobile Manufacturers. (Exact date to be announced.)

## Race Meets, Hill Climbs, Etc.

- Apr. 24.....—Briarcliff Trophy Race, Westchester County, N. Y. Robert L. Morrell, chairman.
- Apr. 28.....—Norristown, Pa., 125-mile Endurance Run, via Lancaster and Reading, Norristown Automobile Club.
- May 4-5.....—Harrisburg-Philadelphia and Return, 300-mile Endurance Run, Motor Club of Harrisburg.
- May 15.....—Chicago, Algonquin Hill Climb, Chicago Motor Club.
- May 16.....—Hartford, Conn., 200-mile Endurance Run, Automobile Club of Hartford.
- May 30.....—Bridgeport, Conn., Sport Hill Climb, Bridgeport Automobile Club.
- May 30.....—Wilkes-Barre, Pa., Giant's Despair Hill Climb, Automobile Club of Wilkes-Barre.
- May 30.....—San Francisco, Endurance Run under the auspices of the Automobile Dealers' Association.
- June 6.....—Worcester, Mass., Dead Horse Hill Climb, Worcester Automobile Club.
- June 24-27.....—Chicago, 1,200-mile Reliability Run, Chicago Motor Club.
- July 7-8.....—Buffalo, N. Y. National Convention of the American Automobile Association.
- July 9.....—Buffalo, N. Y., Start of the Fifth Annual A. A. A. Reliability Touring Contest.
- Sept. 5-9.....—San Francisco-Los Angeles Reliability Run, under the auspices of the Automobile Dealers' Association of San Francisco.
- Sept. 14.....—Chicago, Annual Economy Run, Chicago Motor Club.

## FOREIGN.

## Shows.

- May 17-31.....—Austria, Budapest Automobile Show.
- May 17-June 2.—Moscow, Russia, International Automobile Exposition, Automobile Club of Moscow.
- December.....—Paris, Eleventh Annual Salon de l'Automobile, Grand Palais, Automobile Club of France.

## Race Meets, Hill Climbs, Etc.

- Apr. 25-May 25.—Industrial Vehicle Competition, Automobile Club of France.
- May.....—Paris, Competition for Agricultural Automobiles, auspices of "L'Auto." (Date to be announced.)
- May 7.....—Sicily, Palermo, Targa Florio Circuit, Voiturette Race, Automobile Club of Italy.
- May 11-16.....—Ireland, Irish Reliability Trials.
- May 1-31.....—Automobile Taxicab Competition, France, Automobile Club of France.
- May 10.....—Sicily, Targa Florio, Automobile Club of Italy.
- May 31.....—Russia, St. Petersburg to Moscow Race.
- June 1-18.....—Reliability Trials for Pleasure Cars, Automobile Club of Great Britain.
- June 14.....—Mount Cenis Hill Climb, for Voiturettes.
- June 9-17.....—Touring Competition for the Prince Henry of Prussia Prize, Germany, Imperial Automobile Club.
- June 15-19.....—Scotland, Scottish Reliability Trials.
- July 6.....—Voiturette Grand Prix, Dieppe Circuit (Automobile Club of France).
- July 7.....—Grand Prix of Automobile Club of France, Dieppe Circuit.
- July 13-17.....—Ostend, Belgium, International Race Week, Automobile Club of Ostend.
- July 20-30.....—Ardennes Circuit Races and Coupe de Liedekerke, Automobile Club of Belgium.
- Aug.....—France, Coupe de la Presse, Automobile Club of France. (Exact date to be announced.)
- Aug. 29-30.....—France, Mont Ventoux Hill Climb, Vauclusien Automobile Club.

## THE FIRST 1908 BLUE BOOK.

This week the Class Journal Company, publishers of THE AUTOMOBILE and MOTOR AGE, bring out the first of the 1908 series of "The Official Automobile Blue Book," carrying forward by a second full year the work first undertaken on broad and permanent lines in the compilation and publication of the one-volume edition of 1906.

While covering practically the same territory as the corresponding 1907 volume, approximately one-half of the entire territory has been written new from personal observations with odometer measurements—a wider sweep of the country than was ever before attempted to cover by this means.

There are 292 separate routes in the book, totaling 19,135 miles. Of the 313 maps, 133 are route maps, principally in the margins of the pages; 137 city maps, with 35 full-page maps. There are, in addition, three double-page maps, whose six pages cover the territory in general from the Hudson River, Long Island Sound and Lake Champlain to the Rhode Island-Massachusetts Coast, the upper Maine border and the Canadian line. By the aid of these maps and the index (both of places and of trunk lines, the latter being a framework by which separate runs are listed consecutively as through routes), a tourist is able to find his way with a convenience and certainty never before approximated, practically throughout New England.

As an example of the thorough character of the present work, it may be cited that one is able to plan a round trip to and from the White Mountains from New York by three different trunk-line routes, complete connections to and from which are easily made by the regular routes of the different sections from practically any point in New England. The highest point reached by the matter compiled new for the 1908 edition is Dixville Notch, N. H., this route skirting the upper Connecticut River Valley to Colebrook, crossing over through Dixville Notch to Errol on the N. H.-Me. border, thence down the Androscoggin Valley to Gorham and the White Mountains.

The important stretch between the White Mountains and Portsmouth was written new from personal observation for the first time, with odometer mileages throughout, and many another stretch that has heretofore been traveled with uncertainty, if not with actual difficulty, has been made plain by this latest edition, the number of whose pages have been increased over 200 to accommodate the additional material.

The Blue books are again brought out under the exclusive official endorsement of the American Automobile Association. The New York State volume is now entirely in press, and will shortly be issued, followed by Volume No. 3, dealing with New Jersey, Pennsylvania, the South, and the West. There is shortly to be an addition of a fourth volume, covering the Middle West, announcement of which will soon be made.

The extension of routes to and from the Middle West evidences both the rapidly broadening field of the Blue books and the growth of touring in that territory. A separate volume, published by the Class Journal Company, is the "Metropolitan Automobile Guide," comprising 74 separate round trips to and from New York and Brooklyn, ignoring the State lines and other divisions that necessarily exist in a work as large as the Blue books.

A striking example of the past and present was accorded Hartford, Conn., voters at the recent city election. It has always been the custom in Hartford, as in other cities, to round up delinquents at the polls, and for this purpose horse-drawn vehicles have been used. This season, however, there was hardly a horse outfit to be seen, and the automobile had things pretty much its own way. Every dealer in the city rented all his spare cars, and these were at a premium. Both candidates made their campaign speeches in autos. One owner of a commercial car fitted up the vehicle with side seats and brought the voters from the factory districts by the dozen or more. Of course, the livery men, that is, those who do not use autos, are sore all through.



REVISED AND COMPREHENSIVE OFFICIAL AUTOMOBILE BLUE BOOK CHART OF AUTOMOBILE LAWS ENFORCED AND IN EFFECT UP TO APRIL 15, 1908. When travelling in "exempt" States, automobilists should display home license numbers and tags. When travelling in non-exempt States remove number and tags of home and other States.

	Registration with	Fees	Numbers	Lamps	Non-Residents	Speeds
CONN.	Secretary of State Hartford.	Annual registration of car. Less than 20 H. P., \$3.00; 20-30 H. P., \$5.00; 30 H. P. up, \$10.00. Operator's license (annual) \$2.00.	Must be obtained from Secretary of State—\$1.00 for set of two	Front and rear lights required	Exempt 10 successive days, but home-State number must be carried.	Must not exceed 25 miles per hour, "or at a rate of speed greater than is reasonable and proper"
DEL.	Secretary of State. Dover.	\$3 for registration; \$2 for driver's license, both annually on January 1st.	5 in. high, front and rear, with year and initials of State.	1 white forward; 1 white rear illuminating number; 1 red rear.	Exempt 10 days a year.	10 m. curves and intersections; 12 m. cities and towns; 20 m. elsewhere. Chains prohibited except on dirt roads.
D. C.	The Automobile Board. Washington.	None, but license to operate required	3 in. rear; initials "D. C." 1 in. high.	2 forward at sides, and 1 rear showing red and white.	Exempt 60 days; but non-residents must register with the Automobile Board within 24 hours.	Fire limits, 12 m.; 15 m. parks; 8 m. across streets; 6 m. corners; 4 m. certain designated streets and corners; 20 m. outside fire limits; 12 m. meeting and passing vehicles.
ILLINOIS.	Secretary of State. Springfield.	\$2.00; professional chauffeur \$1.00	Front and rear 4 in. high; letters "ILL" 1 in. high, black on white ground.	2 in front with Nos thereon 1 in. high; 1 red rear.	Exempt so far as State is concerned.	15 m. outskirts; 10 m. built-up section; 6 m. corners and crossings; 20 m. elsewhere.
INDIANA	Secretary of State. Indianapolis.	\$1.00.	4 in. front and rear, 1st 3 letters of State, 4 in. high; white on black.	"Shall carry lighted lamps."	Exempt.	8 m. closely built portions, 15 m. other portions; 20 m. outside.
KY.	No State provision. Local authorities should be consulted.	No State provision.	No State provision.	1 white front, 1 red rear.	Exempt so far as State is concerned.	6 m. crossings, bridges, curves and descents; 15 m. elsewhere
MAINE	Secretary of State. Augusta.	\$2.00 registration; \$2.00 license. Both indefinitely	Supplied by State.	1, location and color not specified.	Exempt	8 m. cities, towns, etc. 15 m. elsewhere; prohibited certain roads, Bluefield, Camden, Mt. Desert, Readfield, Eden, Castine.
MD	Secretary of State. Annapolis.	Owners \$3.00; chauffeurs \$2.00. Perpetual; owner needs no driving license.	3 in. high front and rear, white on black background, 1/4 in. wide. Remove all other tags.	2 white front, with number 2 in. high; 1 red rear.	Not exempt	6 m. sharp curves, intersections of prominent cross-roads; built up portion of city; elsewhere, 12 m.
MASS	Highway Commission. Boston	\$5.00 registration, annually. \$2.00 private operating license, perpetual. \$2.00 pro. chauffeur's license, good year from date.	Front and rear. Plates furnished free.	1 white each side front, containing numbers 1 in. high.	Exempt 7 successive days	12 m. cities; 20 m. country; 8 m. curves and intersections.
MICH	Secretary of State. Lansing	\$1.00; 50c. renewal. Same for chauffeur. Both good year from date.	Front and rear 3 in. high, with State abbreviation 1 in. high; black on white or vice versa.	2 white front, 1 red rear	Exempt if home State grants reciprocity	8 m. business portions, 15 m. other portions; 25 m. outside.
MO.	Secretary of State. Jefferson City.	\$5.00 owner; \$2.00 chauffeur.	Front and rear 3 in. with "Mo." 1 1/2 in. white on black.	2 white front; 1 red rear.	Exempt.	Business portion cities or villages 8 m.; elsewhere 15 m. Corners and crossings 6 m.
N. B. Canada.	Secretary of Public Works. Fredericton	Registration \$5.00; renewal \$1.00; chauffeur \$2.00.	Tag in rear, numbers 3 in. high, black on white. Letters "N. B." 1 in. high.	1 white light front showing numbers 1 in. high.	Not exempt.	Built-up sections 7 1/2 m.; elsewhere in town or city 12 m.; 15 m. open country; 4 m. bridges, curves, descents and crossings.
N. H.	Secretary of State. Concord.	Registration \$3.00, perpetual \$1.00 for yearly operator's license annually. Chauffeur's \$5.00 annually	Front and rear, supplied by State.	2 containing number not less than 1 in. high.	Exempt	8 m. business districts, compactly built sections of cities or towns; elsewhere 20 m.
N. J.	Commissioner of Motor Vehicles, Trenton, or Deputies, of which there are several in the State and two in New York City.	Registration \$3.00 for under 30 H. P., \$5.00 for 30 H. P. or more. License fee \$1.00 under 30 H. P.; \$2.00 above; good one year from date	Front and rear 15 in. and not more than 36 in. above ground. Must be 4 in. high and 1/2 in. wide, with letters of State same dimensions.	2 white front, showing numbers 1 in. high; 1 red rear.	Not exempt.	1 m. 7 min. curves; 1 m. 4 min. intersections or within 200 ft. of horses or animals upon highway; 1 m. 5 min. built-up portions of city, town or village; elsewhere 1 m. 3 min. Chains prohibited on macadam, unless 2 in. ice or snow.
N. Y.	Secretary of State. Albany	\$2.00 owners, chauffeurs, manufacturers. 50c for manufacturer's duplicate. Good for all time. (Owners do not need driver's license.)	Rear 3 in. high, with initial letters of State not less than 1 in. high.	2 white forward, with number not less than 1 in. high; 1 red rear.	Exempt.	10 m. business and built-up portions; 15 m. where houses average less than 100 ft. apart; 20 m. country; 4 m. curves, bridges and steep descents
OHIO (Old Law).	No State provision. Local authorities should be consulted.	No State provision.	No State provision.	1 or more white, front; 1 red, rear.	Exempt so far as State is concerned,	8 m. business and closely built up portions of municipality; 15 m. other portions; 20 m. elsewhere.
OHIO (New Law) Not yet in operation because declared unconstitutional.	Secretary of State. Columbus	Owner's registration, \$5.00 under 30 H. P.; \$8.00 each additional 10 H. P. Owner's license, \$5.00 30 H. P. or less; \$8.00 each additional 10 H. P. Chauffeur's, \$2.00.	Rear, white on black ground, 4 in. high and 1/2 in. wide, with letters "OH." 4 in. high	2 white front, showing numbers 1 in. high and 1/2 in. wide; 1 red rear.	Exempt	10 m. built-up portions of city, elsewhere in city 15 m.; elsewhere 20 m.; approaching bridges, dams, sharp curves or descents. 4 m.
ONTARIO. Canada	Provincial Secretary. Ottawa.	\$4.00 for first year, \$2.00 for each renewal. Good calendar year	Front and rear; plates free.	1 front with number 2 in. high; 1 rear illuminating number. Search lights not allowed.	Not exempt.	Cities, towns and villages 10 m.; outside 15 m.
PENNA.	State Highway Department. Harrisburg.	\$3.00 for driver's license, yearly renewal Jan. 1. Registration of car unnecessary, but driver's license must be affixed.	5 in. high, front and rear. Tags supplied free; remove all other tags.	At least 1 white front and 1 red rear, showing number	Not exempt, except from municipal license in Philadelphia 48 hours.	10 m. cities and boroughs; elsewhere 20 m.
QUEBEC. Canada.	Comptroller Provincial Revenue. Quebec, or Agents	\$5.00 registration. Owners' and chauffeurs' license \$5.00. Expires April 1st each year	4 in. high, 1 in. wide, front and rear with "Quebec" same size underneath.	2 white forward, showing number 1 in. high, 1 red rear. Searchlights not allowed.	Non-resident Canadians exempt; others must register	Towns and municipalities governed by Municipal Code, 9 m.; 15 m. elsewhere; 7 m. sharp curves, bridges, steep descents, intersections and crossings.
R. I.	Secretary of State. Providence.	\$2.00 owners; \$10.00 manufacturers and dealers.	3 in. high rear	Such as Secretary of State approves.	Exempt.	No State provision, but local authorities should be consulted
VERMONT	Secretary of State. Montpelier.	30 H. P. or less, \$3.00 more than 20 H. P.; \$5.00 \$2.00 operating license both perpetual. Chauffeur's \$2.00 annually	Front and rear supplied by State.	2 white front showing nos.; 1 red rear illuminating nos.	Exempt if registered in a home State granting reciprocity	10 m. cities, villages; 25 m. outside
*VIRGINIA. (New Law.)	Secretary of State. Richmond.	\$2.00. Postage on plate 15 cents.	Rear; supplied by State	At least 1 white forward, and 1 red rear, illuminating number.	Not exempt.	6 m. curves, intersections; 10 m. built-up portions of cities, villages or where there is a gathering of persons or horses; elsewhere 15 m.
WEST VIRGINIA.	State Auditor, Charleston.	\$10.00. Good May 1 to April 30.	Front and rear, supplied by State.	No provision.	Not exempt.	No State provision. See local authorities

\*VIRGINIA: The new law of Virginia is only applicable in those counties adopting the act. Most of the counties have adopted the law

The State of New Jersey has just adopted a number of changes in its automobile law which will go into effect June 1, 1908. (For details see page 544.)



# THE AUTOMOBILE

Vol. XVIII Thursday, April 16, 1908 No. 16

## THE CLASS JOURNAL COMPANY

Flatiron Building, Madison Square  
New York City

H. M. SWETLAND, President

### EDITORIAL DEPARTMENT

A. G. BATCHELDER, Managing Editor  
R. F. KELSEY, Associate Editor C. B. HAYWARD, Engineering Editor  
W. F. BRADLEY

### BUSINESS DEPARTMENT

A. B. SWETLAND, Business Manager  
LOUIS R. SMITH FRANK B. BARNETT  
W. I. RALPH, 1035 Old South Building, Boston, Mass.  
C. H. GURNETT, H. E. WESTERDALE, 1200 Michigan Ave., Chicago, Ill.

Cable Address - - - - - Autoland, New York  
Long Distance Telephone - - - - - 300 Gramercy, New York

### SUBSCRIPTION RATES:

United States and Mexico - - - - - One Year, \$3.00  
Other Countries in Postal Union, including Canada - - - - - One Year, 5.00  
To Subscribers—Do not send money by ordinary mail. Remit by Draft,  
Post-Office or Express Money Order, or Register your letter.

### FOREIGN SUBSCRIPTION AGENTS:

ENGLAND:—Illiffe & Sons, Limited, 20 Tudor Street, London, E. C.  
FRANCE:—Boyveau & Chevillet, 22 Rue de la Banque, Paris.  
GERMANY:—A. Seydel Mohrenstrasse 9, Berlin.

Entered at New York, N. Y., as second-class matter.  
The Automobile is a consolidation of The Automobile (monthly) and the Motor  
Review (weekly), May, 1902, Dealer and Repairman (monthly), October, 1903,  
and the Automobile Magazine (monthly), July, 1907.

Copies printed in 1905	- - - - -	730,000
“ “ in 1906	- - - - -	791,000
“ “ in 1907	- - - - -	888,000

## WHEREIN SPEED WILL BE A MINOR FACTOR.

It is a more or less general consensus of opinion that those who look for speed in the coming Briarcliff race will be greatly disappointed. Then, why the race? ask many, for what is a race without speed? This, in brief, may be put down as representing the views of a large number whose chief desire is to see speed, and then more of it, and who look back upon a race merely as a milestone that marks some new achievement in record-making. Racing naturally involves competition, and the maximum speed that the competitors can get out of their machines, otherwise it would not conform to the name. But the mere fact that the maximum speed made does not form a close approach to existing records, or better them, is certainly no reason for prejudging the event as one of little value, as the speed enthusiasts have done.

Practical autoists, on the other hand, regard the event as one that will prove the ability of a car to stand the most gruelling test to which an automobile could possibly be put. The marvel will not be that the cars will be unable to break existing speed marks, but that it will be possible to drive them at anything more than an ordinary rate of travel over such a corkscrew course. It is, in fact, a test of their "rough-ability," and the honors will doubtless go to those that can stand the pounding and can still keep going, rather than those capable of high speed under favorable conditions. And the driver will be a factor fully as important as the car itself. Viewed in this light, the Briarcliff race should prove of

value, as it is an already well-established fact that the auto can go much faster than it is safe to drive it.



## WHY NOT AN AUTOMOBILE MUSEUM?

Progress in automobile building has been so astoundingly rapid that the machine of a decade ago compares with its present-day successors much the same as the first locomotive of Stephenson does with those of the present. The progress that it required almost a century to compass in the latter field of endeavor has been condensed into less than ten years in the case of the automobile, so that it would seem fitting that steps be taken without further delay, to preserve the prototypes of the power-driven road vehicle in the manner accorded the locomotives of bygone generations.

In other words, is it not time that an automobile museum were established to afford an honored resting place for those early American representatives of the automobile with which inventors struggled to make the modern vehicle possible? Things move so fast nowadays that, within a few years, it is doubtful if many of these first cars will still be in existence. They are antiques only as gauged by the measure of progress that separates them from the automobile of to-day, so that they are not hallowed by the three-score years or more of service that caused old locomotives to be treasured, but judging from the viewpoint of advance alone, they are equally venerable and should not be allowed to find their way to the junk-heap unhonored. The National Museum houses most of the early American locomotives and it already has an automobile exhibit or two. It seems fitting that it should have an automobile section wherein may be gathered to rest all that remains of pioneer attempts in this field on this side of the Atlantic.



## A SIDE LIGHT ON THE NEW YORK-PARIS RUN.

It is quite apparent from the contribution of our Paris correspondent last week, that the French manufacturers' plans in supporting the round-the-world race have sadly miscarried. It was confidently expected that the triumphal passage of several French cars across the United States would be exactly the thing that was required to demonstrate the overwhelming superiority of the foreign product, thus bringing before the population of a country that has bought more French automobiles than any other outside of England the fact that they were still immeasurably better than anything that could be turned out here, regardless of the great advances made in recent years. Government reports have it that French exports of automobiles to this country have been on the decline during the past few years, just as they are to other countries, but the United States constitutes a market not to be relinquished without a struggle, so that doubtless this most daring feat, engineered by two newspapers for publicity purposes, did present a much-sought opportunity. But alas for the triumphal progress! Gone forever, and with it one of the greatest opportunities for the French maker to shout *Vive la France!* There is still Siberia. Bah! says monsieur, disgustedly. Mongols and Tartars do not buy cars, French or American. Who cares what happens to the cars there? Wait for the Grand Prix. We will show them.

## CHICAGOANS WILL TRY A NEW FORM OF HILL-CLIMB

CHICAGO, April 13.—Chicago is so accustomed to setting the pace in the way of framing up original motor competitions that the townspeople are not at all surprised by the originality shown in the program arranged for the third annual hill-climb at Algonquin, Ill., drafted by the Chicago Motor Club, which were announced this week. In the first place, Chicago is the only promoting city in the country to hold a double climb, one from a standing start in the morning and the other from a flying start in the afternoon, two hills being used but both figuring in the final reckoning. It was the first to adopt the handicap formula which has proven so successful and all the way through it has shown originality far above the ordinary.

The fundamental principles of the previous climbs are retained in the rules just announced, but the technical committee, which is responsible for the conditions, has broadened the scheme until now it looks to be as near ideal as it is possible to arrange climbs. The handicap formula will be retained, and there will be four classes in this division, classified according to piston displacement. Then there are four other events which are free-for-alls, in which straight time will be the deciding factor, this part of the program being arranged to meet the demand of some of the dealers who assert the public cannot understand the handicap formula. Then there is a segregation of motor buggies which are put in a class by themselves, while the amateur driver will be given a chance to show his ability in two events, one a handicap and the other a free-for-all. The club has adopted the A. A. A. definition of an amateur, and will see that no wolf in sheep's clothing creeps in. Another feature of the card is a team competition. This will not be separate, however, the three cars of one make with the best percentage showing being declared the winner.

The handicap formula which will decide the winners in those events consists of multiplying the cylinder capacity of the motor

by the time in seconds, this result being divided by the weight of the car with driver, the winner being the one with the lowest percentage. The date selected is May 15, and Algonquin will again be the battleground, it being the intention to use Perry hill in the morning for the standing start effort and Phillips hill in the afternoon for the flying start trials. The entry fee is set at \$30 in all but the amateur events, for which \$20 is charged, but the club will rebate half the fee in case of starting. This is to prevent "four-flushing," and has worked well in previous events promoted by the club.

It has been decided that touring cars must carry four adults of an average weight of 132 pounds, while the roadsters, which carry two, will be penalized 264 pounds in the handicap formula to make up for the deficiency. The full card is as follows:

### Division 1.—Buggles and Roadsters.

- Class A—Open to motor buggies with wheels 36 inches or over and fitted with solid tires.
- Class B—Touring cars or roadsters of piston area under 50 square inches.
- Class C—Touring cars or roadsters of piston area over 50 and under 65 square inches.
- Class D—Touring cars or roadsters of piston area over 65 and under 90 square inches.
- Class E—Touring cars or roadsters of piston area over 90 square inches.

### Division 2.—Free-for-all.

- Class F—Stripped chassis, roadster, baby tonneau or racing cars of piston area 90 inches or over.
- Class G—Touring cars, five or seven passenger, of piston area 90 square inches or over.
- Class H—Two, three or four-passenger roadsters, stripped chassis or racing cars of piston area under 90 square inches.
- Class I—Five and seven-passenger touring cars of piston area under 90 square inches.

### Division 3.—Amateur Events.

- Class J—Western amateur handicap championship for four or six-cylinder cars, the winner to be determined by club formula.
- Class K—Amateur free-for-all, touring cars or roadsters of any power.

### Division 4.—Team Competition.

- Class L—For teams of three cars of the same make having the best average performance by club formula.

## N. A. A. M. VOTES TO ACCEPT THOMPSON CUP

PROMPT action was taken by the executive committee of the National Association of Automobile Manufacturers at its meeting last week—April 8—upon the report of S. D. Waldon, one of its delegates to the meeting of the A. A. A. central conference committee the previous day, on the matter of trade support to the American Automobile Association in its promotion of national contests of various kinds.

The members present voted unanimously in favor of accepting Jefferson deMont Thompson's offer of a \$3,000 cup for a permanent stock car race trophy by way of a prize for an annual international contest. The N. A. A. M. board also confirmed the pledges of its delegates to back up the A. A. A. in its withholding and granting of sanctions and to support ex-

clusively as national competitions the three great annual promotions of the national organization—the annual reliability touring contest, the Vanderbilt Cup race, and the proposed annual event for stock car chassis.

It is practically assured that the American Motor Car Manufacturers' Association at its next meeting of the committee of management will take similar action in conforming the pledges of its delegates to the central conference committee meeting.

At the N. A. A. M. an appropriation of \$500 was made toward entertaining the delegates to the good roads and good laws convention at Buffalo, which is to precede the start of the annual reliability tour on July 9.

### SEALED BONNET TEST FOR HOOSIERS.

INDIANAPOLIS, IND., April 14.—The first sealed bonnet endurance contest the city has ever had will be held under the auspices of the Indianapolis Automobile Trade Association on May 20. The three events will be arranged according to the horsepower and possibly for runabouts and touring cars. The course will be a triangular one, about 150 miles long. It is likely that the rules, which are to be arranged next week, will provide that cars shall run a certain number of hours each day, thus avoiding night running. There will be no great attempt at speed.

The routes will likely be arranged to include several good sized cities and towns so that the dealers and manufacturers entering cars can get full benefit of all the advertising possible.

### PHILADELPHIA'S USE OF A DUST-LAYER.

PHILADELPHIA, April 13.—After a long series of experiments extending back to last summer, the Fairmount Park Commission has directed Superintendent Vogdes to begin the regular use of terracolio over all the principal driveways in the park. This liquid, which is a composition of asphaltum oil and water, will be sprinkled liberally over the roads once every week or ten days throughout the summer. Superintendent Vogdes declares, as a result of his experiments, that the terracolio treatment will not only save the city money, but will add much to the comfort of those who use the drives, whether horsemen or automobilists. The estimated cost to the city is a half cent for every square yard sprinkled.

## WHAT MAY BE CONTAINED IN NEW MASSACHUSETTS LAW

BOSTON, April 13.—Automobilists from other States will have to toe the line when driving in Massachusetts if the bill which has been reported by the committee on roads and bridges passes the legislature. Under the law as it now stands, automobilists registered in other States are permitted to drive in Massachusetts for seven days without registering here. If they commit any offense against the automobile law during that time there is no penalty in the way of revocation or suspension of registration or license. As a matter of fact, many cars registered elsewhere have been driven in Massachusetts all summer, possibly going out of the State at intervals in seeming compliance with the law. Some of these visiting machines have been held up for overspeeding and other offenses, and their drivers have been fined. But, after paying the fine, they could continue to drive, whereas a Massachusetts driver in similar circumstances might lose his license and perhaps the registration certificate of his car.

The new bill proposes to correct this matter by adding to the clause permitting the operation of outside automobiles for seven days without a Massachusetts registration, the sentence: "But if any such non-resident be convicted of violating any provision of the laws of this commonwealth relating to automobiles and motor cycles and to the operation thereof, by any court or trial justice, whether or not he appeals, he shall thereafter be subject to and required to comply with all the provisions of this act relating to the registration of motor vehicles and the licensing of operators thereof." In other words, if the driver of a visiting automobile is convicted of overspeeding in a lower court, he must forthwith register his car in Massachusetts and secure a license to drive, thus putting himself and his car directly under the control of the Massachusetts Highway commission, the same as resident drivers and owners.

The new bill also contains a number of other provisions, among them being the granting to the Highway commission of the right to summons witnesses and administer oaths, and put-

ting on the commission the duty of investigating all fatal accidents by means of a corps of inspectors provided for the purpose, these inspectors to be paid by a special appropriation of \$3,000 and from fees received by the commission. The bill also gives the commission discretionary power to suspend the license of any person whom it may consider incompetent and improper to operate, and it further qualifies the law so as to prevent a person whose license has been suspended or revoked from continuing to drive by carrying his chauffeur in the tonneau. Failure to display the registration plate assigned a vehicle is made an offense punishable by fine or imprisonment.

Under the advice of the Attorney General's office the committee has changed the section of the bill which provided a fine or imprisonment and loss of license for going away "without stopping and making himself known after causing any accident to any person, or any serious accident to any property, unless he can prove a justifiable excuse." This clause now reads, "or who without a reasonable excuse therefor goes away without stopping and making himself known after causing injury to any person or property." The bill also provides for the immediate suspension of the license of a person convicted of reckless driving, operating while under the influence of intoxicating liquor, or running away after an accident, and this suspension is to take place whether or not the person appeals.

The commission is given power to issue certificates and licenses to members of the foreign diplomatic corps without charge, to collect a fee of two dollars for examination of applicants for licenses, and to charge fees of fifty cents each for duplicates of registration certificates or licenses.

The committee has reported "no legislation necessary" on the Governor's recommendation for a tax on automobiles, graded according to horsepower. This is not the end of the matter, however, for it is generally understood that there will be an attempt on the floor of the house to substitute a bill for the unfavorable report of the committee.

## NEW JERSEY'S NEW LAW WILL TAKE EFFECT JUNE 1

TRENTON, N. J., April 13.—Unusual preparations are being made to carry into effect the provisions of the new automobile law which becomes operative June 1 next. State Commissioner Smith now has 10 paid inspectors, and 20 unpaid inspectors on his staff, to instruct local authorities and investigate complaints. What interests the autoist most in the new law is the increased rate of assessment it reveals. Cars of less than 10 horsepower must henceforth pay \$3 annually, \$5 for machines of from 10 to 20 horsepower inclusive and \$10 for cars of 30 horsepower and above, while drivers' licenses have also been increased from \$1 and \$2, to \$2 and \$4, according to the horsepower of the car handled, the dividing line being at the 30 horsepower mark.

Makers' annual registration certificates will be at the rate of \$5 each, and will be limited to five cars, for which \$25 must be

paid. These licenses are to be transferable. To accommodate the cab companies, blanket licenses permitting them to drive their vehicles 15 miles within the borders of the State will be issued at a cost of \$100 per annum. Henceforth identification marks will be furnished by the State and all registrations will expire on December 31. Each number tag will also have stamped upon it the manufacturers' serial number, to prevent counterfeiting and running a car without renewing its license. Motorcycles will also be compelled to carry identification marks. Among the other changes in the new law as compared with the old, is a provision making it a misdemeanor to throw glass or other cutting substances on the roadway, also one empowering the road commission to expend not more than \$1,000 annually for the erection of warning signs. The money collected is to be expended for road improvements.

## INDIANA IS TROUBLED WITH DOUBLE REGISTRATION

INDIANAPOLIS, April 14.—City Comptroller Breunig has decided that automobile owners need not pay the annual city license of \$3 until the county and State courts have passed on the validity of the license ordinance. There was practically no other step the comptroller could take, in view of the fact that owners have refused to pay their 1908 license fees until a case now pending in the Circuit Court is decided. Should the Circuit

Court decide against the owners, the case will be carried to the Supreme Court, and by the time that court reaches a decision 1908 will probably be past history. About 900 automobile owners in Indianapolis and several hundred in cities where license fees are charged will be affected. It is believed that the State law, providing a State registration, forbids municipal ordinances conflicting with it.

## AUTO CLUBS FEEL THE IMPULSE OF SPRING

### CONNECTICUT'S BIG CLUB HELPS SIGN POSTING.

HARTFORD, CONN., April 13.—The fifth annual meeting of the Automobile Club of Hartford was held at the Rathskeller of the Hotel Heublein Wednesday evening and the following officers were unanimously re-elected for the ensuing year: President, W. F. Fuller; vice-president, C. H. Gillette; secretary, G. K. Dustin; treasurer, C. D. Alton, Jr. President Fuller in the annual message outlined the growth of the club during the past year, which showed that 150 members had been gained, the membership now being 200. Five new members were elected, and State Highway Commissioner James H. MacDonald was elected to honorary membership of the club. The matter of permanent quarters came up for discussion and was turned over to the entertainment and house committee, consisting of N. F. Allen, chairman; T. Welles Goodridge, R. D. Britton, W. L. Wakefield, and Albert M. Kohn. Clarence E. Whitney was elected chairman of the membership committee, N. F. Allen of the entertainment and house committee, H. P. Maxim of the contest committee, Colonel George Pope of the rights and privileges committee, C. H. Veeder of good roads committee, and C. D. Rice of signpost committee.

The State highway commissioner has been instructed that he will be accorded the hearty co-operation of the club in the work which he has undertaken, and the sign post committee will see to it that proper warning of dangerous spots is placed along the highway.

It was voted to hold the annual orphans' day run on June 5, the same date that other clubs in the American Automobile Association hold the event. Before a great while the club will doubtless be housed in its own quarters. The rapid growth of the organization renders this move essential. Interest runs high in the forthcoming endurance run, the initial attempt of the club, and every indication points to its complete success. The weekly club lunches at the Heublein have proven very successful and have stimulated interest in the organization. The members have been prevailed upon to obey the present law to the letter, as thereby only will the retention of this measure be possible. The present law, which was brought about mainly through the work of the local club, is everywhere regarded as one of the best in the country.

### CLEVELAND CLUB BUILDING MODEL ROAD.

CLEVELAND, April 13.—Earnest effort continues to characterize the administration of the Cleveland Automobile Club. Thanks largely to the active recruiting work of its secretary, C. J. Forbes, Jr., the membership has grown so rapidly that the club has aspirations toward pushing Buffalo for banner membership honors in another year.

The club has started work on the new model road just east of Cleveland. A three-mile stretch of road is being built, the entire work being undertaken by the automobile club. It is hoped that when completed it will serve as an object lesson to the State. The club officers have put more hard work and worry on this proposition than any work yet undertaken.

### ANOTHER ENDURANCE RUN AT HARRISBURG.

HARRISBURG, PA., April 14.—The Motor Club of Harrisburg has scheduled May 4 and 5 for its second annual endurance run. Five loving cups will be offered as prizes. One of them, which has been donated by Vance C. McCormick, president of the club, is for private owners driving their own cars. The classification will be: class A, for touring cars costing \$2,500 and over; class B, for touring cars costing less than \$2,250; class C, for runabouts costing \$2,000 and over; and class D, for runabouts costing less than \$2,000. There will be six checking stations on the first and three on the second day. At the conclusion of the run the cars will be put through a rigid examination.

### NEW LEADER FOR NEW JERSEY'S BIG CLUB.

NEWARK, N. J., April 13.—Announcement has just been made of the regular ticket nominated by the board of trustees of the New Jersey Automobile and Motor Club, to be voted upon at the annual meeting on May 4. The list of nominees will be formed to embrace some noteworthy changes in the official list. Angus Sinclair, a veteran automobilist, has determined to give up the cares of the presidential office. In his place the trustees have suggested that Paul Heller be placed. Another loss that the club will feel most keenly will come through the retirement of H. A. Bonnell from the secretaryship, for a rest demanded by his recent illness. Mr. Bonnell for the same reason will be compelled to relinquish the secretarial chair of the Associated Automobile Clubs of New Jersey. He has been a hustling, tireless, efficient and popular incumbent, and has consented to serve on the club's board of trustees. A. B. Le Massena, who is the local agent for the State Department of Motor Vehicles, has been nominated to succeed him. This will practically mean the moving of the local agency to the clubhouse.

W. Clive Crosby is the nominee for vice-president. Dr. James R. English has been named to succeed J. C. Coleman as treasurer. The trustees proposed are H. A. Bonnell, W. C. Shanley, Dr. F. B. Meeker, A. S. Scherer, and F. A. Croselmir. Messrs. Bonnell and Scherer and Dr. Meeker are new members and Mr. Shanley is named for re-election. Joseph H. Wood and W. F. Kimber hold over.

Although no definite announcement has yet been made, the chances favor the club's holding a 12-hour endurance run on Decoration Day, open only to members. The matter of a possible co-operation of the trade will be referred by Secretary W. H. Ellis, of the local trade association, to his organization. It is believed that the dealers will find more time to support an endurance run planned for later in the season.

### L. I. A. C. FITTING UP A COUNTRY HOME.

BROOKLYN, N. Y., April 13.—Much interest has been aroused among autoists generally in Greater New York by the Long Island Automobile Club's perfected plans to open a country clubhouse at Bay Shore, L. I. In this new country home they see advantages of which many would like to avail themselves. Accordingly the Long Island Automobile Club is looking for quite an influx of applications for membership from the members of the fraternity, not only across the big bridges but in the various towns of the island, to which the clubhouse would prove a convenient and attractive rendezvous. The board of governors are pushing preparations for the opening of the new home with vigor. The estate, which is locally known as "Bridgewaters," is a 39-mile ride from the club's city house in Brooklyn. The house is back about 300 feet from the Merrick road. It is 3,900 feet from Great South Bay, where an excellent beach, suited for bathing, is located. The grounds are large and laid out with shrubbery and shade trees. There are spacious piazzas on three sides of the structure. The house is to be conducted as a pleasant rendezvous for members and their families. A competent manager will be in charge, the table will be of the best, and a limited number of sleeping rooms will enable members who so elect to make the country house their living quarters.

### JOINT CLUB AT SAGINAW AND BAY CITY.

SAGINAW, MICH., April 6.—Saginaw and Bay City automobilists are planning the formation of an automobile club, for the purpose of promoting good roads in Saginaw, Bay City and surrounding counties, to give endurance and excursion runs, and to protect automobile interests. A meeting will be held this week to perfect the organization. If the club proves to be a success it is the intention eventually to build a fine clubhouse between here



and Bay City, near the Saginaw river. There are about 500 machines in use in Saginaw, Bay City and the nearby towns. It is the intention to have the club formed before the Detroit reliability run takes place.

**DETROIT'S CLUB TO LOOK AFTER ROADS.**

DETROIT, MICH., April 13.—If highways in the vicinity of Detroit are not kept in shape it will be through no fault of the Automobile Club of Detroit. Franchises on all the toll roads leading out from the city recently expired, and it is now up to private enterprise to make any improvements that are necessary. Realizing this, the club at its annual meeting raised the dues \$5 annually, the money thus secured to be used for good roads. Under the energetic direction of Edwin S. George, chairman of the good roads committee, a fine gravel road has within the last two years been built from Circle City to Pine Lake. Farmers who assisted in the work, although at first indifferent, now find they were benefited no less than motorists and are in hearty accord with the work. It is hoped to arouse interest on the part of residents along highways where toll roads are now no more, that good roads may become general.

The past year was the most successful from every standpoint in its history. Sixty new members were added, making a total of 252. The finances of the organization are in excellent shape, and it was decided to spend several thousand dollars enlarging the clubhouse at Pine Lake, so as to better care for the increasing membership. Officers elected for the ensuing year are: President, Harry Skillman; first vice-president, Arthur Pack, Pontiac; second vice-president, Christian H. Hecker; third vice-president, Walter Brooks; secretary, Frank H. Whelden; treasurer, J. T. Anketell; directors for three years, Dr. E. A. Christian, Pontiac; J. T. Anketell, Harry Skillman.

**AGAIN COUGHLIN MAY HEAD WORCESTER CLUB.**

WORCESTER, MASS., April 13.—Stillman L. Shaffer has been appointed active secretary of the Worcester Automobile Club. The club has engaged Arthur G. Dodge as secretary for the Dead Horse hill climb committee, which event will take place June 6.

The board of governors has named these officers to be voted for at the annual meeting, May 5: President, John P. Coughlin; vice-president, C. A. Harrington; secretary, George E. Stimpson; treasurer, H. P. Bagley; two members of board of governors, F. P. Gay and Alfred Thomas.

**FORT SMITH, ARK., ORGANIZES A CLUB.**

FORT SMITH, ARK., April 13.—Thanks to the efforts of Fred A. Rentzel, there was organized last Monday night the Automobile Club of Fort Smith. It started with 30 charter members and elected the following officers: President, John Vaile, Sr.; vice-president, George H. Lyman; secretary and treasurer, Fred A. Rentzel. The above, with Frank Handlin and C. E. Speers, will make up the board of governors. It will join the Little Rock club in organizing a State association with A. A. A. affiliations.

**ARKANSAS VALLEY CLUB'S NEW OFFICERS.**

PUEBLO, COL., April 10.—At its annual meeting last Saturday the Arkansas Valley Automobile Club elected the following officers for the ensuing year: President, Lee Graham; secretary and treasurer, Homer E. Brayton. These with the following were chosen as trustees: George E. King, Dr. Crum Epler, and L. G. Walker. The club will begin an active campaign for the betterment of the roads leading into Pueblo.

**100-MILE RUN "TO SHOW MISSOURIANS."**

KANSAS CITY, Mo., April 11.—The Automobile Club of Kansas City, at its regular monthly meeting on Thursday night, decided to hold a 100-mile endurance run to St. Joseph as soon as the proper details can be arranged. The treasurer reported a balance in the bank of \$1,787.47. The membership is now 180.

**WINTON OWNER WON CAPE MAY CUP.**

PHILADELPHIA, April 13.—"Winton No. 10," owned and driven by F. M. Johnson, annexed first prize, the handsome Hotel Cape May cup, in last Saturday's "roadability" run of the Quaker City Motor Club. Johnson drove his car over the 92-mile course at a rate of speed which brought him to the finish but a fraction of a minute shy of the 5 hours 54 minutes 18 seconds which the contest committee had agreed upon as the official legal speed limit time. Of course, none of the 29 contestants knew the limit agreed upon by the committee, and the majority of them were very circumspect, adhering very closely to the 10-mile-an-hour limit in towns and villages and opening up to the 20-mile limit in the country.

Dr. E. M. Lengle, driving his own Matheson, captured second place, arriving at the finish 25 minutes ahead of time. Another Winton, driven by A. E. Maltby, was awarded third place, having anticipated the official time by 26 minutes. Some of the contestants took chances and "beat it," not a few cars arriving at the "Cape" before 4 o'clock—a rate of speed which would render them amenable to the speed laws, if apprehended. Fortunately, the South Jersey *Vidocqs* were all looking the other way on Saturday, and no one reported having had a run in with them. Although heavy rains during the early part of the week had torn out the road badly in some places, the going generally could be characterized as "fair to fine," and that so many of the contestants honestly sidestepped the temptation to "throw 'er wide open" argues well for Quaker self-control.

Arriving at the "Cape," the automobilists found the town agog, the occasion being the official opening of the big new Hotel Cape May, a modern inn, with accommodations for a thousand guests and costing upwards of a million dollars. The awarding of the prizes to the winners was made the occasion for the exchange of felicitations by all hands over the bright prospects for Cape May's rehabilitations.

**FOR THE PRINCE HENRY TOUR.**

BERLIN, April 10.—The committee of the Imperial Automobile Club for the Prince Henry Tour points out the fact to intending competitors that every car must be fitted with a speedometer in such a position that official observer can always control the speed rate the car is traveling at. The new itinerary for the event, which has been greatly altered, runs as follows:

Berlin-Stettin .....	298.5	kilos
Stettin-Kiel .....	398.8	"
Kiel-Hamburg .....	368.3	"
Hamburg-Hanover .....	287.9	"
Hanover-Cologne .....	328.9	"
Cologne-Trier .....	250.3	"
Trier-Frankfort .....	230.5	"

Total.....2,163.2 kilos

The hill climb will take place at Bacharach in the Rhine district and the speed trials at Itzelioe.

Competitors must also note that a reduction has been made in the weight of the cars, which now must weigh 800 kilos and not 860, as in the first set of conditions. This does not include spare tires, inner tubes, petrol, water and oil, but in order to facilitate the weighing-in cars may appear at the scales with oil, water and petrol, the weight of which will be doctored against every car as 60 kilos and the minimum total weight must be at least 860 kilograms, with engines of a total piston surface of 227 square centimeters. The weighing-in takes place at Charlottenburg, June 7 and 8, and with two exceptions the vehicles start daily at 6 A.M. On June 12 they are let off at 5 A.M. and on the final day at 7 A.M.

**ANOTHER CLUB ORGANIZED IN IOWA.**

OLWEIN, IA., April 13.—The Olwein Automobile Club has been organized. It starts with a membership of 25, and with J. F. Cole as president and W. J. Brennan, secretary. Other officers will be chosen when the following committee on constitution and by-laws makes its report: Leo Kerwin, T. E. Kint, J. W. Ridler, W. H. Bloom, and R. C. Baker.

## THINGS NEW IN THE INDUSTRY AT DETROIT

By BERNE NADALL.

DETROIT, MICH., April 13.—THE AUTOMOBILE and *Motor Age* being desirous of ferreting out all the newest things on the tapis for the season, as well as the novelties in the way of tried and proved principles in which the makers are more particularly interested, I made it a point to call early at the Aerocar Company plant, as I had learned this concern intended to market a new model at a popular price. I found considerable activity in the various departments, and learned that C. A. Benjamin was in Los Angeles, pushing the Aerocar line on the coast. This year the Aerocar people will bring forth an entirely new model of slightly smaller type at a price that should be an attractive one to both the agent and the moderate-priced customer. This newcomer will be known as Model E, and will be water-cooled. The design of the car is nifty, and the body construction is of a triple combination type, being transformable into a two-seated, baggage-carrying runabout, or a three-seated runabout, or a four double-bucket-seated tourabout. In the illustration of this neat appearing combination car it will be noticed the general design shows a good balance, which is not always the case with constructions of this kind. It also will be seen by noting the illustration of the single rear seat that the various changes are made quickly, and without leaving that unfinished look such as often is found in detachable rear seats. This little car is fitted with a Continental engine, and the chassis contains long springs, racy fenders, and full equipment.

The policy of the Aerocar Company to supply either air or water-cooled engines as in former models will still be adhered to. These models also have been drawn down to finer lines, and the various refinements which the Aerocar people have put into them make them more attractive than heretofore. As this concern also is of the opinion that the time is ripe for a cheaper car it has sprung a surprise on the motoring world by listing these 4 by 4-inch air and water-cooled models at a considerable reduction, considering the class of articles made. Those who have wanted a good touring car of medium power at a medium price are certainly benefited by this tendency to market a smaller and lower priced car. If this is a criterion of the values to be offered the small town agent will be very much benefited.

A larger 40-horsepower model is also going through the factory. This model, designed by Mr. Melanowski, late of the Dragon and other firms, appears to be of good workmanship, and has ample power, but Advertising Manager Campbell declares the season for large cars will be an off one, and the company therefore would not now place this model on the market. As he termed it, the motor industry has its off seasons like other branches of the commercial world, which, he said, is a repetition of nature—as the apple tree does not bear good and sound fruit each season.

### The 1908 Thomas-Detroit Has Many Refinements.

Of the several new products which are finding a good market few are more appealing than the 1908 Thomas-Detroit. This car, with its numerous refinements, is very much like a French production. The design closely follows the lines of the best continental practice in every detail, even to the position of the front axle, which is thrown out almost in line with the radiator. The executive staff of this concern is made up of young men, from Mr. Chapin, who has only recently returned from the western coast, where he claimed to have found good picking,

down to the front door guardian seems to be well suited to meet the various requirements. Also the congenial works manager, Mr. Brady, was found at his desk filling in the morning orders for Thomas-Detroits in green ink.

When asked what particular feature of the car was his greatest delight, Mr. Brady replied, "the car itself." To judge it as a whole was his wish, and the remark became more forcible as more of the factory was visited. I found the car had no frills and was what one might call a common-sense engineer's job—a well balanced proposition, such as the very best representatives of the modern American automobile of the very highest type have come to be within the past three or four years. A construction eminently fitted to withstand unlimited hard usage.

One of the points that appealed as worthy of mention, however, is the oiling system of the engine. The system is not new, but the Thomas-Detroit people have made it quite successful by the application of a well-designed pump and sight feed. The pump is integral with the engine and is of the gear-driven type. It is placed on the bottom piece of the crankcase, and pumps from a duct in the bottom of same up through the dash sight feed, thence by outside leads to the three main bearings of the

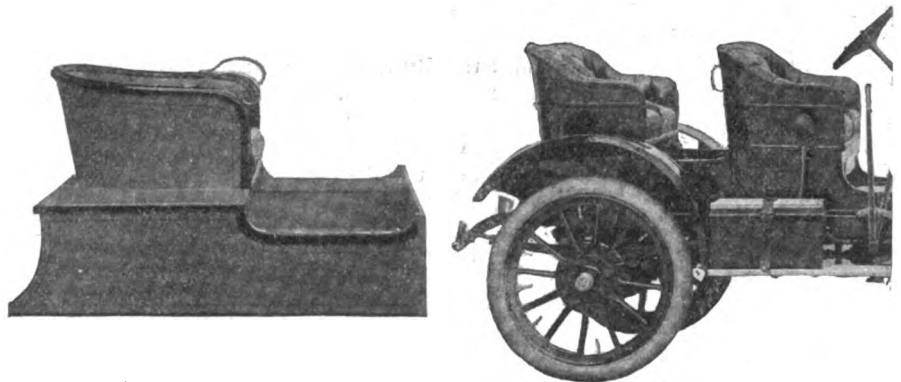

New Aerocar, Model E, with Triple Combination Body.

crankshaft. This is following the best European practice, as it gives a constant crankcase level as well as a splash feed; but the sight gauge seemed a decided improvement in that it forms a sort of visible tell-tale at all times of any obstruction in the flow of oil. As shown in an illustration, the complete system, with the leads to and from the pump and crankcase through the gauge, is compact. In another illustration the gauge itself is shown, with the pump pipe ending in a goose-neck shape in the glass gauge. It will be obvious to one that as the pump lifts the oil up to and through the gauge any debris that may perchance find its way into the leads will cause the sight gauge to fill up beyond the neck of the pipe as the pressure from the pump always is there; and unless free and continuous flow of oil is obtained the gauge must fill, which at once tells the driver something is wrong and needs attention. Usually there is nothing but a thin pipe with a glass tube inserted in it, or a drip arrangement which is, as a rule, so oily one cannot detect such discrepancies at a glance. In filling the case with oil the method of determining the quantity put in is by two pet-taps at different heights in the crankcase. If oil runs out of the highest tap the case is full. The Thomas-Detroit people claim 500 miles can be run on one filling.

As in all parts of the Thomas-Detroit, the gears are put through a rigid test to secure perfect working in every car sent out. Road tests of cars, even 200 or 300 miles, will not always secure the loosening up of stiff gear parts. While the engine generally is worked out, in many cases the gears or the gear

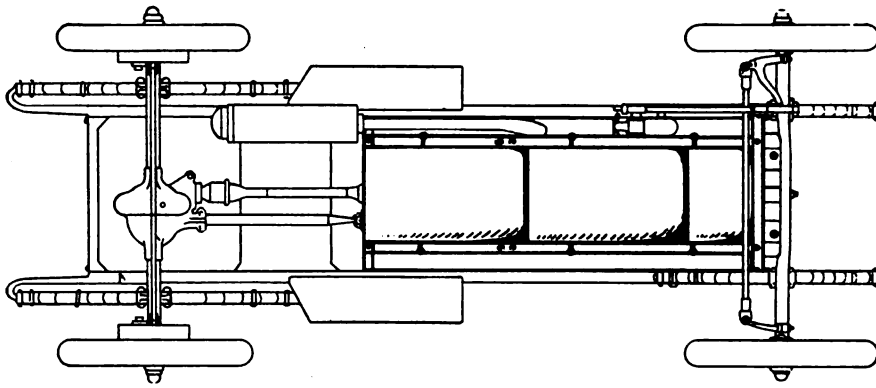

Detachable Mud Apron or Underpan of Thomas-Detroit

levers will still show newness, or stiff action. The Thomas-Detroit gear test is equal in every respect to the engine test or I might say sufficient for the demand. The gear set is of the Brown-Lipe pattern. I should term this pattern of gear-shifting the flip type.

Another point which deserves mentioning is the fine underpan, which is fitted. An underpan does not seem to be of much importance and often is considered a great nuisance. It is always clumsy, ugly and hard to take down. In the case of the Thomas-Detroit pan, the design has been studied with the same care that characterizes the running parts; in fact, I found this condition to prevail in numerous parts which are considered of minor importance by some of the makers. Detaching or attaching of the pan can be effected without the use of tools within two or three minutes.

In the first place the design is part of the design of the car frame itself, the sub-frame having grooves to take the swaged edge of the pan, which is slid into place from a point under the gearbox forward to the front of the car, making a dust-proof fit. In addition to the grooves supporting the pan, six spring clips or hooks are sprung into holes made for the purpose. The whole pan, which is semi-cylindrical, is 24 inches across, thereby taking up very little room under the car, and at the same time being almost unnoticeable.

The spring suspension is ample. It is a noticeable fact that this part of the American motor car has shown such improvement within the last two years that to-day it can claim to be the leader in this respect. The exemplification of this fact never was made plainer than when the foreigners recently commenced to traverse this continent in the New York-to-Paris tour. I also can include the frames, and other parts of the chassis of American-built cars, which no longer are a trouble, notwithstanding the almost impossible road conditions. A glance at the illustration, which also gives a view of the underpan, shows the long wide springs fitted to the Thomas-Detroit cars.

Numerous other interesting data could be given of this new

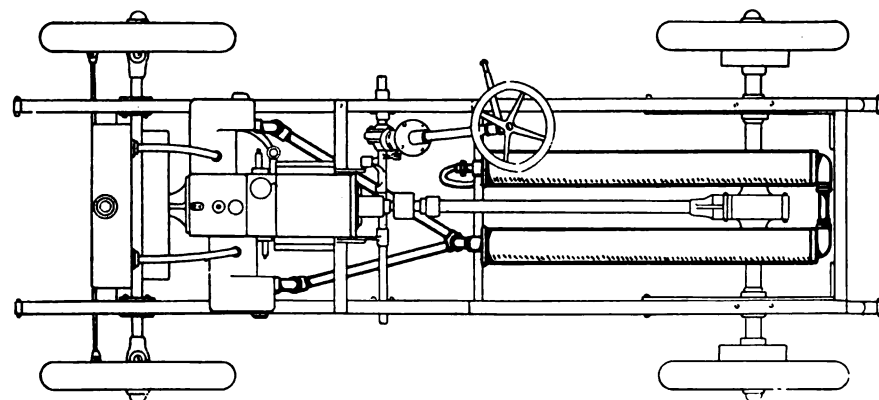

Double Muffler as Applied to the Silent Northern.

proposition, but as I am dealing only with special matters space limits me. However, it is worthy of note to point out advantages shown in the use of large ball-bearings, and solid plain crankshaft bearings which usually are not considered good practice; but in the case of this firm, good design and careful assembling have been found to give every satisfaction. Also the good balance of the car enables the engine to produce a horsepower for every 60 pounds it carries in dead weight. Considering that this firm is hardly two years old, and that it has turned out something more than 600 cars, which are giving satisfaction in every part of the country, the achievement stands out as a credit to the industry.

There is nothing that succeeds like success and when it is applied to actual experience it becomes the concrete fact. No prejudice can assail the product of an institution that has become successful no matter what opposite view one might make of it. It is often said that the double opposed or the one-lunger is a freak or a frost or some such expletive as ruthlessly slaughtering in its purport; but the proposition remains defensible as long as the promoters can show a return for their investment.

**The Silent Northern.**

Since the day the Silent Northern received its appropriate name it has steadily gained in favor. Northern cars, those of the double-opposed, two-cylinder type, are better to-day even than ever before. They are made in a first-class shop and made well. There are not many cars of medium price that can boast of so well equipped a shop and such a good organization as have the Northern. The main office is located in Detroit, but an equally large factory at Port Huron is under the same control. A visit through the Detroit works was sufficient to learn that this place is a solid institution and that it is a fine plant. To acquaint the reader with practices such as might interest the engineer as well as the layman buyer, it is not amiss to point out one or two advantages such as have been obtained by the above mentioned conditions. In the first place, it is plain that manager, foreman and mechanic are wholly in touch with each other. This unity of officers and men means that any leak that might otherwise occur will be detected almost at once and made right before it is too late. Also any cheaper or better way to perform a difficult piece of work would just as readily be discovered. A case in mind is one where sand-blown cylinders are transformed into first-class bright castings, by galvanization. These castings, like most castings of such a nature, were too often of the pinhole variety, or sandy, and sometimes porous—which condition was not always discovered until the casting had been machined, fitted in a car and sold. I am told that as high as 45 per cent. of the castings received was sometimes rejected, much to the annoyance of the foundry and the recipient, and that it is imperative to do something to overcome the trouble.

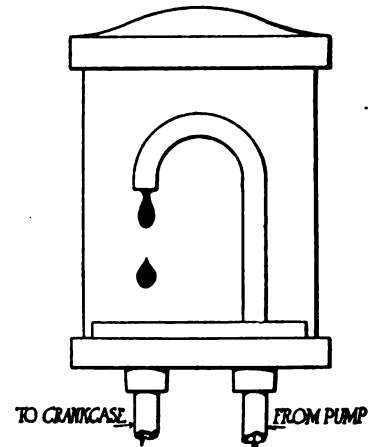

Thomas-Detroit Dash Tell Tale Lubricator.

While I did not learn whose idea it was to galvanize the cylinders, I found them to be clean and clear and of a close and smooth texture. The cleanliness alone seemed to compensate for the extra cost incurred galvanizing them, which is stated to be about \$1.25 each. The rejected castings at the present time do not equal two per cent. and the fact that the interior of the cylinders also is coated makes them somewhat proof from quick carbonization, the surface being more of a repelling nature than one of adhesion, which is obvious from the very nature of the rough interior of an ordinary casting, the pebbly surface holding dirt much firmer, especially gas burnt oil products. Also it is noticeable in machining that the interior of the cylinder is of such a reflected brightness that the work became much easier on account of being quite visible. Thus it is explained that a vital benefit is obtained by the unity of an establishment.

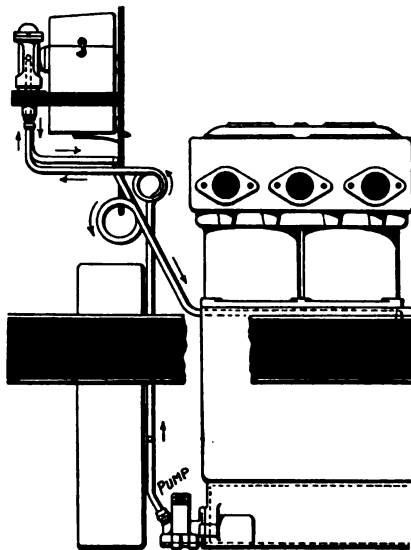

Thomas-Detroit Oiling System

Other novel things on the car are the exhausting of the engine gases, the spring and shackle suspension, the plug position, and the absence of torsion or stay rods, also the interesting manner in which the finished cars are tested with regard to hill-climbing ability. Taking the plug position first, it will be seen in illustration how the plug is pocketed in a remote corner of the cylinder. I am told the position given the plugs in Northern double-opposed engines is one which was adopted after much experimenting on the subject. While it seems wholly contrary to all laws regarding spark plug theory this firm advises that its plug trouble since placing it as shown has quite vanished. The sooting, carbonizing and oil-wetting troubles so frequent in the four-cylinder upright engines are thus eliminated by what most people term very bad practice, or, in fact, a practice I never before saw, except, I believe, some years ago when the Mercedes firm tried it for a while. This is such an interesting subject a whole book could be written on it, and I would very much like to hear from other sources on experiences gained by others, as much data could be collected that would be of general benefit to the trade. In drawing attention to the general suspension of the car one illustration, which shows the car on the roller-testing stand, gives a profile of the runabout where it is plainly seen that no torsion rods or stay supports of any kind are used. This is another instance where everyday practice has been thrown to the winds, but, from what I learn, good results accrue. Heretofore the one or two other firms I have known which have tried the torsionless chassis have eventually given way to popular sentiment—or perhaps for other reasons—and fitted such members, but this firm refrains from believing that it is necessary in the car in question, and it states it has been experimenting on such lines for a number of years. It has even followed, or perhaps originated, certain spiral spring principles which have been incorporated into the drive shaft—only to be thrown out again as no good, after long experience.

This spring idea, which once I saw in

France, was at one time heralded as the solution of the flexible drive *trés bon*, but it soon went the way of other such arrangements, yet the difficult problem as instituted into this car seems to work out well. The firm states it has yet to have a complaint from that source. The Northern people believe in it and claim their numerous cars now running in all parts of the country bear them out. I have made it a point to try the principle since leaving the works and find in the action a lifting and falling of the full elliptic rear springs which are fitted to the car. While it may appear from the fact that the remark implies a defect in the spring and falling of the spring ends E and F the reverse is the case. This rising and falling in no way seems unsound no more than the deflection of a spring. In starting, which I had demonstrated by using the high gear, I saw a clear swiveling action, apparently thoroughly practical in this case, receiving the sudden application of the power to the outer periphery of the driving wheels through the springs, giving a partially retarded movement to the car. The jerk, so prone to the usual direct drive, is quite absent and it seemed quite unlikely much trouble could occur from the adoption of such a principle here. Suddenness of action does not take place and therefore any carelessness that might seemingly cause a snap somewhere appears very remote. Only one universal joint is used at the front end. The engine also is set slantwise, declining towards the rear, making the drive more direct. At the universal joint a sleeve is fitted, which practically is unlimited in its movement either forward or backward, as much as 1 1-2 inches being apparent under the most sudden conditions. As one must judge by ocular demonstration, as seeing is believing, it cannot be said the practice of the Northern is wrong. The isolated position of the spark plug, the torsionless drive and the galvanized cylinders should be enough at one time to talk about, but in the case of the Northern it apparently thinks from both ends, as it were, like the burning of the candle; however, it does not believe in hiding its light under a bushel as it makes it a point to bring all prospective buyers into the works to see with their own eyes.

The company also works from both ends, as Mr. Gunderson, the manager, puts it, in that it commences to assemble its chassis by fitting the monster mufflers first. As it seems correct to do it, it again is another unorthodox proceeding which is in no wise a derogatory or assailable practice. The manner adopted of exhausting the engine gases is novel in the practice of carrying it out only. It is exactly what others are slowly coming to, namely, expansion room spread over large areas and a minimum of baffling. Look at the large four-cylinder cars of good make to-day and you will see a 50 per cent. increase in the size of the exhaust pipes, expansion chambers or mufflers over what existed only a few years ago. Everybody knows that if they could hold the exhaust gases long enough to cool to a temperature equal to that of the outside atmosphere, when deposited into the open air there would be no sound at all. This is just what is happening everywhere now. The Oldsmobile was one of the first to give plenty of expanding area in America and that car has become known as one of good muffling. The manner of passing away the hot gases on the Northern is illustrated, the

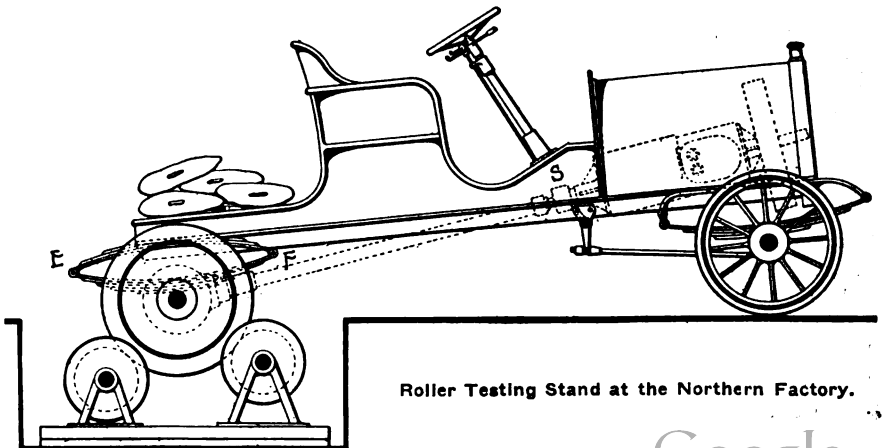

Roller Testing Stand at the Northern Factory.



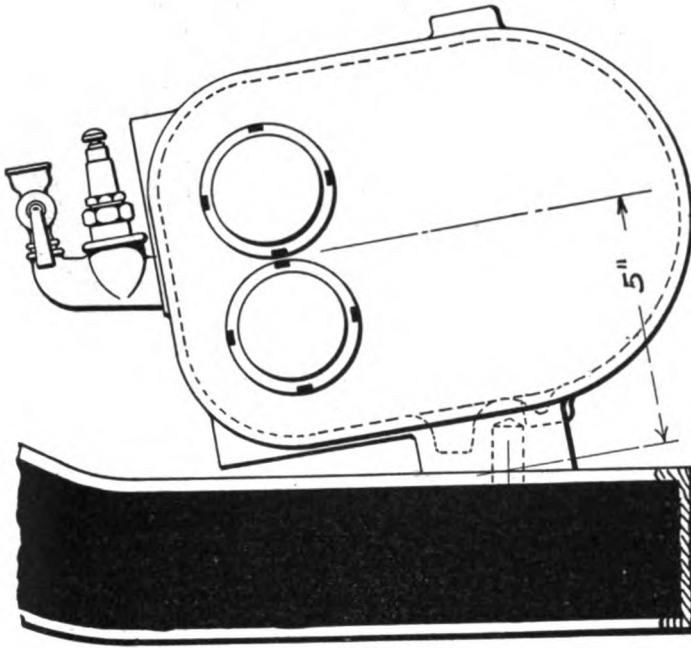

Northern Motor Spark Plug Scheme, Showing Isolation.

drums being what is termed the high pressure and the low pressure boxes respectively. The left box only has a perforated pipe running through its extreme length which retards the passage of the fresh hot gases enough to reduce their expansion properties to a point low enough to cause them to be quite weak, after which they are passed into the second right chamber and allowed to flow out upon the air, quite cooled and weak. It is claimed the two-cylinder horizontal engine is much harder to make quiet than the vertical engine; however, the Northern motor seems to have earned its sobriquet honestly and simply. It will be obvious to anyone that back pressure almost is reduced to nil.

Detroit is known for its motor car originality, and I have found it quite true; but it should also imply that its originality is mostly sound as I have found any variation from the regular paths to be based wholly on good engineering practice. Sometimes art or style will predominate over science, but not so marked here. Take, for instance, the French custom of hanging the spring shackles, which is followed the world over. It may be right to design that little shackle to hang obliquely always. It looks as if it need not be so, but the whole world seems to have followed the French. And perhaps the French only copied it from the landau of German origin or the calèche which we Americans can see by taking a little trip to the town of Quebec in Canada where they are the favorite horsedrawn vehicle to-day. One illustration shows the style the Northern has adopted. The company points out the reason for such a change and the feasibility of it seems apparent. It is a fact that an obliquely hung shackle will only allow of a spring rebound equal to the tension in the spring. A quick drop into a hole and a further sudden fall of a motor car running at good speed will be sufficient to show what happens to the body, or a car when the shackles are oblique. The hinge movement of the shackle on the return of a spring is not the same as that on its downward throw, and it is apparent the shock absorber has its existence mainly from this cause. Hang the little shackles vertical—or nearly so, sufficient to act as desired—and the return of the spring will be confined to the power of its tension or deflected state. It must return through the shackle on dead center, as it were, and not through the shackle as a hinge. That is the reason the Northern has so set its shackles. If this argument can be assailed I fail to see how, as the function of the shackle primarily is to allow for the varying lengths of the spring under the varying stresses. In the shop I find good engineering practices of the modern school and the equipment is

first class. The gears are cut right in the factory and one of the latest Gleason arc machines is turning them out at a good rate of speed. Jigs are used throughout the shop and no fewer than twenty-four separate parts are being ground for model C, a remarkable instance of good shop practice when the price of the car is considered. Organization and practical mechanics alone can account for such results.

Particularly interesting is the manner in which this firm tests its cars for hill-climbing. I specially asked Mr. Gunderson for a sketch of the rollers on which his tests are given. The idea as applied here is novel, particularly the means of altering the stiffness of the grade. The rollers are such as are used in other places to run out the engines, but in this instance the Northern people have so arranged the rollers that simply altering the spindle distances, which allows the car driving wheels to drop lower or rise higher as the case may be, changes the resistance given to the power plant. It is plain that such a principle theoretically figured out would give such results as could only be obtained by actually driving the car up inclines, the only difference presumably being the taking away of the traction of the front wheels. This, however, is no doubt partly compensated for by the small resistance that must necessarily occur at the point of the driving wheels where they are in contact with the rear roller. It must be remembered that the drivers must touch on two points and the weight is as great on the rear roller as on the forward one. It strikes me that this idea is one that while crude to begin with will work out to a greater degree of satisfaction than any other of which I know.

#### APPLE ELECTRIC COMPANY IS ORGANIZED.

DAYTON, O., April 13.—H. V. Apple, O. D. Apple, and V. G. Apple have withdrawn from the Dayton Electrical Mfg. Co., and have gone into business on their own account as the Apple Electric Company. The new company has already placed on the market its improved storage battery, and will shortly announce its new dynamo-floating storage battery ignition system, which will embody a number of up-to-date improvements. V. G. Apple still retains his interest in the Dayton Electrical Mfg. Co., and will continue to serve as vice-president.

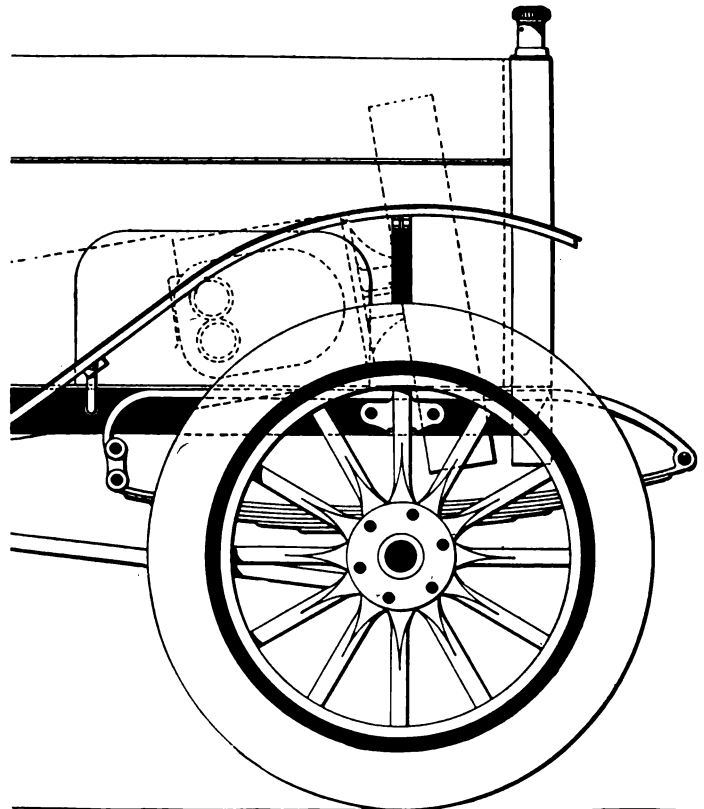

Vertical Spring Shackle as Shown on the Northern.

## AUTO INDUSTRY NEWS FROM HARTFORD MOST PROMISING

**H**ARTFORD, CONN., April 13.—The outlook for the coming season in this city is particularly bright, and both the local factories report business as good. The Electric Vehicle Company's plant is running with a force of about 250 men, and all the 29-horsepower cars that can be built are being sold as soon as ready. The Boston agent wanted 50 cars for immediate delivery, and made good his request by a certified check for the amount of purchase, but delivery in the desired time could not be made. The Pope Manufacturing Company is shipping quite a batch of the Hartford models, and on one day last week 14 were sent over the rails to buyers. The Hartford Rubber Works Company is running overtime. This is another tangible indication that business has improved. This plant has been operated on a short time schedule more or less all winter.

The retail dealers have had a very satisfactory time of it since the Hartford show last January. The Capitol City Auto Company will market the Mitchell this season, and thus far have made many sales. A. W. Peard has taken on the Overland runabout, heretofore unknown in this city. The Connecticut Steel & Wire Co. have taken on the Stoddard-Dayton, in addition to the Reo, both new ones to Hartford. The Elmer Automobile Company continues another season with the Ford runabout, the Britton Brothers sell the Maxwell, while the Palace Automobile Station will market the Thomas, Autocar, and Oldsmobile. Every one of these dealers has had a lively season and things look unusually bright. The same holds true of Brown, Thomason & Co., agents for the Packard, Stevens-Duryea, and Cadillac. T. Dudley Riggs represents the Isotta Fraschini and Simplex, and regards the outlook as most promising. The Post & Lester

Co. have opened a downtown branch on Asylum street in the heart of the business district. Hartford motoring circles are optimistic, and there is no reason to be otherwise.

Despite all denials to the contrary, there is every reason to assume that the Packard Motor Car Company will shortly be in possession of the Electric Vehicle Company plant. It is rumored that the Columbia light gas car will be continued as Packard No. 2, and that a Packard transmission on the rear axle will be substituted. The motors for the commercial vehicles will be built at Detroit and shipped complete for assembly to this city. The least that can be said, is that when the plant goes it will be acquired by the Packard company, and this move is much desired by local interests.

Halsey M. Barrett and Henry W. Nuckols, receivers of the estate of the Electric Vehicle Company in the district of Connecticut, have filed with the superior court the following report of March business. The report shows charges on account and cash sales of \$37,457.21, with purchases of \$7,740.27.

The cash statement shows balance on hand, March 1, of \$30,056.90; collected on Electric Vehicle Company account, \$1,138.37; collected on receivers' account, \$41,514.16, and on miscellaneous sales, \$157, showing a total of \$72,711. Disbursements were: Pay roll, \$10,997.49; traveling expenses, \$240; purchase creditors, \$4,152.04; receivers' salaries, \$1,800; receivers' bond, \$400; refund of advance payment, \$1,500; freight and express, \$291.46; telephone and telegraph, \$163.80; salesmen commissions, \$188.18; petty cash, \$181.12; operators, \$2; total, \$19,894.09; balance on hand, April 1, \$52,816.91. This shows a good increase in the cash on hand over the month of March.

## INDIANA FARMERS ARE BUYING AUTOS AND BUILDING ROADS

**I**NDIANAPOLIS, IND., April 13.—Although the season has not far advanced, practically every county in Indiana is arranging to build several miles of roads during this Spring and Summer. In fact, the amount of road building will doubtless exceed that of last year, and the year 1907 was a record-breaker.

As a result of last year's and this year's road building activities, Indiana will have one of the finest networks of improved roads in the country. Practically all road improvement is being done under the recent State law, providing that on the application of fifty property holders in a county an improved road not more than three miles long and connecting two other improved roads, shall be built.

Inquiries have been directed to a large number of counties on the subject of road building, and it is evident that road building in Indiana in 1908 will aggregate fully \$8,000,000, all of

which must be borne by the property holders by assessment.

In Hamilton County, of which Noblesville is the county seat, bids are now being asked for the construction of thirty-six roads, to cost about \$150,000, and aggregating sixty-four miles. Blackford County is preparing to build thirteen new roads; Bartholomew, three miles; Dearborn County, two and a half miles; Hendricks County, two and a half miles; Knox County, three miles; Jackson County, about twelve miles; Clinton County, twenty miles; Daviess County, ten miles; Lawrence County, eight and one-half miles.

It is interesting to note that in almost every instance the farmers are back of the good roads project, lending their best efforts and spending their money. The fact that farmers want rural routes, and are rapidly adopting the automobile, are the principal reasons for the great amount of road building.

### PITTSBURG SHOW RESULTED IN SALES.

**PITTSBURG**, April 13.—With the starting of the Pittsburg-Philadelphia race between the Reo and Maxwell cars, the second automobile show at Duquesne Garden, Pittsburg, practically closed Saturday afternoon. More than 1,000 automobilists were gathered to see the start.

More than \$250,000 worth of automobiles were sold at the Pittsburg show. The Banker Brothers Company alone sold cars to the value of \$87,000. Of the 16 machines they disposed of, 13 were Pierce Great Arrows and 3 Stevens-Duryeas. The Moon people held a special show at the Hotel Schenley all the week and reported large sales. Nine Maxwell cars were sold during the week. Other agencies announced sales of from one to four cars. The sales of accessories were away ahead of the total last year. Manufacturers placed some good agencies.

### BOSTON'S 1909 SHOW TO BE IN MARCH.

**BOSTON**, April 11.—The first meeting of the directors of the Boston Automobile Dealers' Association since the Boston show was held a few days ago, and after Manager Chester I. Campbell's accounts had been examined, it was decided to declare a first dividend from the show profits. The earnings of the show were very satisfactory, though somewhat less than last year.

It was decided to hold the 1909 show at the corresponding time, that is during the second week in March. The directors have had under consideration several propositions for changing the scene of the show, but they decided to continue in Mechanics building, and voted to take a lease of that building for the next automobile show. The management of the show will be decided at the annual meeting in June, when the election of officers will be held, and possibly new members admitted.

### TRACY MAKES INTERESTING FUEL TESTS.

The fact that gasoline of the proper quality for automobile use has been constantly getting scarcer for several years past, has led numerous experimenters, both here and abroad, to try the virtues of alcohol and a number of other promising substitutes for gasoline. One of these that has come to the front is benzol, and Joseph Tracy, who has made a close study of the fuel situation for some time past, made some interesting experiments with this fuel last week, in connection with the dynamometer of the Automobile Club of America. A Simplex run-about handled by Frank Lescault, of the Palmer & Singer Company's forces, was mounted on the rollers of the dynamometer and first run on gasoline for a considerable length of time, and later on benzol. The car was geared high and special attention was paid to the results shown by the grademeter.

No carbureter adjustments were required on changing fuels, the results showing them to be perfectly interchangeable. The use of benzol showed a slightly increased power output and greater drawbar pull. With this fuel the power developed was sufficient to climb a grade of 12.1 per cent., which was increased to 12.2 per cent. by making a special carbureter adjustment, the drawbar pull being 398 pounds, while the maximum with gasoline was 383 pounds, representing an equivalent grade of 11.9 per cent. Mr. Tracy carried on his experiments throughout the week, culminating in the power tests on the club dynamometer, and he said that as a result of these tests and the close investigation that has been made of the subject abroad, he felt convinced that much of the doubt in the fuel situation was solved and that autoists need not fear anything from the rising price of gasoline for the next few years, at least. Benzol is a by-product of the manufacture of coal, and is water-white in color. For use on the automobile, little or no change in carbureter adjustment is necessary, as benzol vaporizes as readily as gasoline. Mr. Tracy will continue to prosecute his investigation, verifying the various findings.

### OLD AUTOCAR RECALLS ANCIENT HISTORY.

A car in the ancient and honorable division of last week's big parade in New York that attracted no little notice was an Autocar of 1901 model. It recalled some early history of the industry and a road feat of the long ago as well, particularly pertinent to a celebration of the wooden anniversary of the automobile. Designed by Louis S. Clarke, the present consulting engineer of the Autocar Company, the car was the first shaft-driven automobile built in this country, either experimentally or commercially, and at a time when there were but three other manufacturers in the United States. The widespread acceptance of the shaft drive theory added to the interest in this parade exhibit. This car established the first automobile road record between Philadelphia and New York, Mr. Clarke driving it from Madison Square Garden in 6 hours 10 minutes. This was in January, 1902, with the roads badly cut up and abounding in frozen ruts. A fresh battery and new tires was all that had been done for this early model to groom it for its appearance in the carnival parade.

The Autocar Company, it will be remembered, was formed and incorporated in Pittsburg in the summer of 1897, it being the outgrowth of the original ideas of Messrs. Clarke, who were firm in their deep conviction that the automobile's utility would be acknowledged by the public the moment it could be demonstrated. At that time, it must not be forgotten, the large rubber companies of to-day had not been formed. Solid tires were the vogue and pneumatic tires were but slightly removed from garden hose. Even more discouraging than the absence of suitable tires was the impossibility of securing a spark coil. None was understood and none was manufactured, so Mr. Clarke had to develop one of his own for the purpose. After three years in Pittsburg, the Autocar factory was moved to Ardmore to secure the benefits of the Eastern markets both as to sales and supplies and to take advantage of the unexampled good roads in the section for a thorough testing of the cars.

### PEOPLE WHOSE SAY-SO IS WORTH WHILE.

**General John T. Cutting, Oldsmobile Co., of New York:** "The prime object of the carnival parade was to give visible evidence to the people of the progress that has been made in the first decade of the automobile industry in this country. This object was skilfully carried out, and the almost total absence of breakdowns, even on the part of the old models, convincingly demonstrated, even to the most skeptical, that the era of practical perfection had been reached. I think nearly half a million persons lined the route of the triumphal march, attracted by nothing more than an industrial display, proving beyond the shadow of a doubt that we are only at the threshold as yet. What percentage of the huge throng will eventually drive their own pleasure machines or install automobiles in their commercial delivery departments it would be folly to guess, but it will undoubtedly be a large one. Every man in the business who rode through that vast assemblage which packed New York's finest thoroughfares was deeply impressed by the interest of the public."

**Benjamin Briscoe, Chairman American Motor Car Manufacturers' Association (discussing the proposed railway show):** "Such an elaborate affair as is under advisement by the A. M. C. M. A. would prove to be a great boon to the industry. The event as planned by the association would give the participants an excellent field of new buyers. It would take the cars to the very homes of the buyers, thus saving the public time and money as would necessarily be spent in attending a New York show. It would reach people who would not and could not attend the show. It is for this class of people that the event would be conducted, and I thoroughly believe it would be a paying proposition based from a strictly business standpoint. It would kindle motoring interests and arouse new enthusiasm in those who at the present time have no idea of purchasing an automobile."

**Hugh Chalmers, President E. R. Thomas Detroit Co.:** "Heretofore automobiles have been bought. Now they must be sold. Reliability in the car and organization in the company, are the two essentials in the future for automobile manufacturers. The country must be so districted and the selling force so organized that dealers or agents can call upon the prospective buyers quickly and frequently. These dealers or agents must be taught the superior features of the cars they sell. And their agencies or branches must be organized to give efficient service to users at reasonable prices. The automobile business has got to a point where it is going to be a case of the survival of the fittest. And the fittest will be those manufacturers who not only make the best cars, but also build up the best selling organization."

**Morris Grabowsky, Grabowsky Motor Vehicle Company, Pontiac, Mich.:** "What builders of commercial vehicles want most is better roads. Heavy motor trucks must have good footing or else they cannot do what is expected of them nor what they are equal of accomplishing. The first requisite in all cases is road conditions favorable to the operation of the commercial vehicle. When the various Legislatures will make adequate appropriations for road improvements then the transportation proposition solves itself."

### AUTO PARADE TO BE PART OF SUBWAY DAY.

JAMAICA, L. I., N. Y., April 13.—Jamaica, L. I., is to make an automobile parade a part of its celebration of the opening of the subway, June 4, 5 and 6. George Morris, chairman, J. P. Disbrow, John Leonardi, George K. Cooke and Charles C. Crossman are the committee in charge. It is proposed to hold the parade at night, to choose a king and queen, and to have a decorative division. A "rose section," in which the paraders will be solely women, their cars being decorated with roses, is to be made a special feature. Hillside avenue, a macadamized boulevard, fully 200 feet wide, running through a handsome residential district, is to be included in the route of the parade, which promises to be the largest ever witnessed in this section of Long Island.

**SUCCESSFUL TRY-OUT OF THOMAS DETROIT.**

After having completed a unique trip, consisting of a 2,000-mile run in midwinter with all the gears, including the reverse, removed, the Thomas-Detroit "Snowbird," a picture of which is shown herewith, has been placed on exhibition at the Chicago salesrooms of the E. R. Thomas Motor Company. The car has not been touched since it ended its trip, and its driver, C. A. Hills, says it is in fit condition for another 2,000 miles under equally strenuous circumstances. One of the most trying tests to which the car was subjected in the course of its run was the ascent of some of the bad hills for which Cincinnati is noted.

The start was made from Detroit in the thick of a blinding snowstorm, Salesmanager Lee Counselman piloting the car as far as Toledo, where C. A. Hills took charge, ice making steering difficult on the way to Findlay, O. From there to Columbus, O., the going was better; thence, the route lay to Dayton, O., much of this distance being a subaqueous trip, owing to the river having overflowed its banks. Salesmanager Counselman again took the wheel and drove the car to Cincinnati. The next large city on the route was Indianapolis, via Richmond. Then on to South Bend, via Peru, Ind., and from there to Chicago, where the test was officially ended.



The Thomas-Detroit "Snowbird" Living Up to Its Name.

**EXPLAINING THE PATRONYM OF THE MOON.**

St. Louis, April 13.—Automobilists and the public at large, particularly in the East, very frequently wonder where the Moon car obtained its name, and sometimes think its appellation is a tribute to the lunar system. However, practically everybody in the West is familiar with the record of Joseph W. Moon, president of the company that manufactures the car, and the source of its name as well. Mr. Moon is one of the oldest and most prominent manufacturers in the West, the name having been a household word in the Middle West for several generations, as the family first became famous prior to the Civil War, as manufacturers of the first rifled shoulder gun placed on the market. In earlier days, the possessor of a Moon gun was an object of envy by his fellow sportsmen, that firearm possessing some individual characteristics that were distinctive and desirable.

In after years Moon buggies and carriages became famous and made the name ever better known through the Central West, the growth of this business having had considerable influence on the success of St. Louis as a manufacturing city. Five years ago Mr. Moon embarked in the automobile business in the same thoroughgoing manner that has distinguished him in other lines, and extended his name to his latest product—hence, the Moon automobile, which was not long in making its title as well known as the other products for which its manufacturer has stood sponsor for many years past.

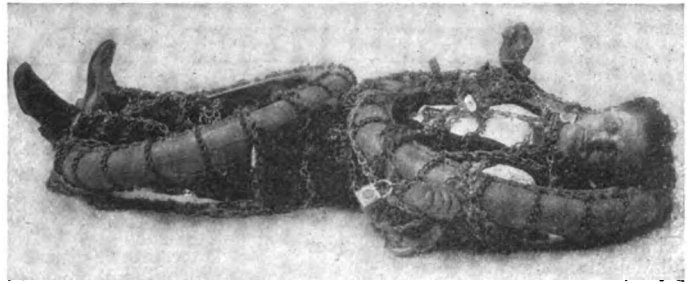

Houdini Enmeshed with Chains Ready for His Test.

**HOUDINI GIVES WEED CHAINS A TUSSELE.**

Harry Houdini, the "Handcuff King," went up against the Weed Chain Tire Grip Company's product at a New York vaudeville show last Friday night. Representatives of the company enmeshed the slippery gentleman in a flesh-cutting network of chains, embracing subsidiary loops, added a couple of chains, bound automobile wheels to the combination, and fastened the whole with padlocks, after laying Houdini on his back. The "Handcuff King" had a long struggle of it, but finally emerged from his cabinet, freed of his bonds, victorious.

**A RIDE FOR ATLANTIC CITY OFFICIALS.**

ATLANTIC CITY, N. J., April 13.—Members of the Atlantic City Automobile Club have been called upon by its officers to furnish 30 cars to carry the Board of Freeholders and prominent city officials on a day's tour of inspection of the roads, with a view to an intelligent and appreciative appropriation of the funds for highway improvement. The precedent set by the local club is one that might be followed to advantage elsewhere.

**INGENUITY OF A TIRE-MAKING PLANT.**

DETROIT, April 13.—It is a mistake to imagine that the ingenuity of tire manufacturers is confined solely to the production of automobile accessories. In proof of this, the Morgan & Wright plant in this city has just completed one of the most unique jobs of its nature ever undertaken. Eighteen pairs of rubber gaskets for use between the tubes of the Michigan Central tunnel under the Detroit River here have been turned out, their purpose being to make the tunnel water tight.

Each of the gaskets is an endless piece of solid rubber, forming a circle twenty-four feet in diameter, and weighs 425 pounds. One side of the gasket is grooved to receive the end of a tube, the other side being flat to meet a similar ring on the adjoining tube. A gasket is run out in a continuous piece by a tubing machine having steel shaping dies. Then it goes to steel molds with a hydraulic pressure of 2,000 pounds to the square inch. The platens of the molds are hollow, and the gasket is vulcanized and the ends joined as it goes through. Three days are consumed in turning out a single gasket.

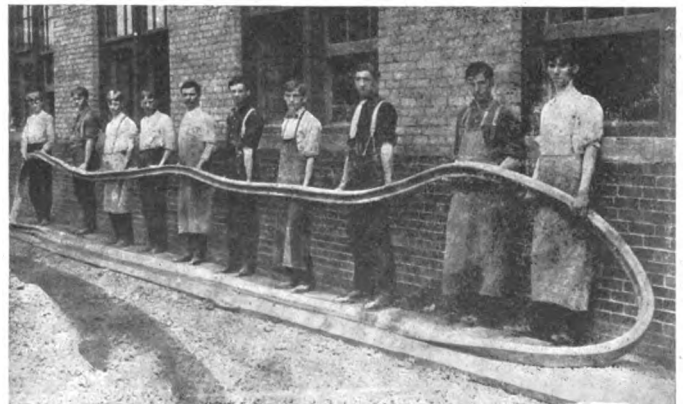

They also Make 24-foot Gaskets at Morgan & Wright's.



## BRIEF ITEMS AND TRADE MISCELLANY

The Chelsea Clock Company, 16 State street, Boston, Mass., announce that their factory and warehouses were not damaged by the recent conflagration which destroyed so large a part of the city of Chelsea, Mass.

The Bergdoll Motor Car Company, of Philadelphia, officially opened its big new establishment at Broad and Wood streets last week with a banquet to the press and trade. Upwards of 150 guests were present.

Z. E. Danner, formerly of the Commonwealth Power Company, Allegan, Mich., and J. W. Reek, formerly of Hillsdale, Mich., have formed a partnership and opened a general garage, supply and repair business under the name of the Angola Automobile Garage, in the Hendry Block, Angola, Ind.

Jacob W. Mason, one of the best-known and enterprising dealers in New Jersey, formally opened his new garage at 350-352 Halsey street, Newark, on Saturday afternoon and evening, April 11. There was music and refreshments; also a full line of Maxwell and Stoddard-Dayton cars, for which he is the Newark agent.

A company has been incorporated in Los Angeles to operate a taxicab service. The concern will be known as the Taxicab Company, its incorporators being Frank J. Spare, J. A. Murphy, M. G. Yoakum, W. J. Wren, and Donald Barker. Orders have been placed for three cars, and the company expects to have 25 in operation in the next few months.

Mrs. Florence Moore, of Seattle, Wash., sailed for Japan March 31, and in the hold of the steamship was her Winton roadster, in which she will tour Japan for two months, after which she will visit China for a tour of three months. Aside from Mrs. Charles J. Glidden, Mrs. Moore is the first American woman to undertake a journey of this nature.

There will be established at Coney Island for the accommodation of automobilists a commodious garage opposite the new Steeplechase, on the block bounded by Surf and Mermaid avenues, West Sixteenth and West Seventeenth streets, by George C. Tillyou. The garage will be able to accommodate 1,000 cars, and will probably be the largest of its type in the world.

Max Grabowsky, one of the founders of the Rapid Motor Vehicle Company, has organized the Grabowsky Motor Car Company. The new concern will have its headquarters in Detroit, and will manufacture a new style of motor for commercial and sight-seeing cars. The entire power-plant will be made removable, to that it can be taken from the car without disturbing any other part.

As an evidence that the Wayne Automobile Company of Detroit has an abiding faith in the future of the industry, it may be cited that the last of a series of contracts for new machinery, to the extent of \$100,000, were signed last week. The first of these new machines, a mammoth drill press, was received last week, and a number of other special pieces of machinery are being set up. President B. F. Everitt is now on an extensive Western tour, visiting the company's agencies.

The United States Navy Department has purchased two automobile ambulances from the White Company, of Cleveland. One of these is for use at the Naval Hospital at

Philadelphia, and the other at the Tuberculosis Hospital at Las Animas, Colo. The new ambulances are similar to those which have been purchased from time to time by the War Department from the White Company. The chassis of the two new ambulances are identical with those of the standard 30-horsepower White touring cars, except that the frame is lengthened out, increasing the wheelbase to 132 inches. The new ambulances have a capacity of four stretchers, besides accommodations for several surgeons, and space for carrying a considerable quantity of medical supplies.

The Mora Motor Car Company, Newark, N. Y., will shortly commence moving into its new plant, but as the whole force is working under considerable pressure at present it will probably be 60 days before the transfer is completed. The first main building, measuring 60 by 406 feet, and



How the Jones Decorated.

One of the most artistic yet simple decorations for New York Carnival Week was that of the Jones speedometer, whose New York headquarters are at the corner of Broadway and Seventy-sixth street.

which is two stories high of mill construction with full skylight, has been completed, as have also the boiler and testing houses. The ground floor of the large building will be entirely devoted to machine work, each department being supplied with power by an independent motor. The second floor will house the company offices, drafting-rooms, and the painting and upholstering departments. The machine tool equipment of the old plant is only two years old, and is the best obtainable. With the large additional quantity that has been ordered, and some of which is already on the ground, the company will have double its present facilities. The site of the new plant comprises a plot of seven acres, situated on the Northern Central Railroad. The testing house is complete in every detail, doors the entire length of the building permitting cars to be driven in and out freely. Five pits have been installed, and automatic ventilators supply them with fresh air and carry off the gas. Wash racks are provided, and all cars will be cleaned by steam.

### NEW AGENCIES ESTABLISHED.

Bert S. Morley, Abbott and Seventh streets, Detroit, has secured the Michigan sales department of the Ferro Foundry and Machine Company, of Cleveland, and is arranging for additional lines.

The Auburn Motor Car Company has just opened salesrooms at 441 North Broad street, Philadelphia. The new concern will handle the Auburn, and will be under the management of F. Liebfeld, Jr. and H. W. Trump.

John J. Gibson, of the Buffalo Automobile Exchange, has taken the agency of the Pope-Hartford car, and will handle it in connection with the Franklin. The Pope agency was formerly held by the Imperial Motor Company.

The Hamilton-Kull Company, 1677 Broadway, New York, has just taken the agency for the Oakland Motor Car Company's output in the eastern territory. The Oakland company is a branch of the Pontiac Buggy Company, Pontiac, Mich., and has been building popular-priced runabouts and taxicabs for about a year past.

The Grout Automobile Company, of Orange, Mass., has established its agency in Boston with Stade & Farrow, who have opened a store at 94 Massachusetts avenue, for the sole purpose of handling the Grout car. Mr. Farrow is an experienced automobile man and handled the Grout in Cambridge, Mass., last year, and Mr. Stade is a well-known business man of wide experience.

The Dow Portable Electric Company, of Braintree, Mass., announces that hereafter the company's entire product will be sold through the George Q. Hill Company, Boston. There will be no change in the local representation, which will remain as at present, viz: New England States, W. J. Connell, 36 Columbus avenue, Boston; Middle States, The Factory Sales Corporation, 235 Randolph street, Chicago; Pacific Coast, L. H. & B. I. Bill, 132 Valencia street, San Francisco.

### RECENT TRADE REMOVALS.

The Tinchler Motor Car Company, South Bend, Ind., has removed its Chicago branch from the Chicago Automobile Club building to 1220 Michigan avenue.

The Triumph Gear Company, Incorporated, formerly the Motor Parts Manufacturing Company, Detroit, has removed from Sixth and Congress streets to Seventh and Abbott streets, and will devote its entire factory to the exclusive manufacture of marine reverse gears.

### PERSONAL TRADE MENTION.

H. L. Thuma, formerly connected with the Imperial Garage, has been appointed general manager of the Columbus Garage & Machine Company, 35 West Mound street, Columbus, O.

R. D. Willard has resigned from the Harrolds Motor Car Company, metropolitan agents for the Pierce Arrow cars, and has gone with the Harry S. Houpt Company, agents for the Thomas.

Louis P. Mooers has left the Moon Motor Car Company, of St. Louis. He has completed designs for a popular priced car which, it is reported, will be manufactured by a new company soon to be formed.

W. M. Perrett, who until recently looked after the Diamond Rubber Company's interests in Detroit, will take charge of a branch of the Empire Automobile Tire Company, to be established there May 1.

Frank H. Yerger, who has gained considerable fame as a driver of the Studebaker on road and track during the past year, has been appointed manager of the Philadelphia branch of the Studebaker Company.

Edward H. Stickels, who has been connected with the Winton and Aerocar companies in New York City, has become connected with the Carlson Motor & Truck Company, 481-487 Sterling place, Brooklyn, as secretary and general manager.

W. H. Workman, of the Packard Motor Car Company, was scheduled to deliver at the Long Island Automobile Club last night an illustrated lecture, entitled "Through Darkest Cuba," setting forth adventures of the Packardians on their 1908 model try-out trip through the Island last January.

E. C. Morse, general sales manager of the E. R. Thomas Motor Car Company, is spending the week in New York City as the guest of Harry S. Houpt, the New York representative of the company. Mr. Morse expresses himself as well pleased with the present condition of the automobile industry.

George Parker, a prominent driver and salesman, has joined the corps of experts which the Bergdoll Motor Car Company is gathering together to man its new salesrooms, garage and repair shop, at Broad and Wood streets, Philadelphia. Parker will probably act as Mr. Bergdoll's mechanic in the Briarcliff race.



New York Renault Branch.

This new garage, spare parts, and taxicab department of the Renault Frères Selling Branch has just been opened at 214-216 West Sixty-fifth street, New York City.

NEW TRADE PUBLICATIONS.

**Matheson Motor Car Company, Wilkes-Barre, Pa.**—An unusual amount of attention has been devoted in the Matheson catalogue for 1908 to showing the essential features of the mechanism and describing its salient features in a clear, everyday, matter-of-fact manner, so that the average owner of a Matheson can recognize them at a glance and realize their method of operation and their importance in the economy of the car as a whole. Every important part of the car has received this same painstaking attention, and is attractively illustrated by half-tones so that the design and construction of the car may be studied in detail without trouble. The book is prefaced with a list of the Matheson agents in various parts of the country, followed by an introductory outline of the Matheson and several pages of half-tones showing the complete cars, while at the end a list of the many victories to its credit are given, together with a few letters from satisfied owners, under the significant heading, "One Hundred Per Cent. of Satisfied Customers."

**Charles E. Miller, New York City.**—This house is now sending out its tenth annual catalogue. It is a book of 216 pages and cover and probably contains more information regarding auto supplies and accessories than anything of the kind ever published. It is such a compendium in fact, that it has come to be known as "Miller's Blue Book of Auto Materials." In this latest catalogue, Mr. Miller lays particular stress upon the fact that the list prices scheduled therein are those given by the manufacturers of the articles, and are standard, and that none of the so-called bargain houses can give large discounts from them. It would be impossible to even give a resumé of the long list of articles catalogued. As the compilers put it, "We either carry it in stock, will get it, or it isn't made," which suffices to tersely sum up the matter where the question of thoroughly covering the ground of automobile supplies and accessories is concerned. Copies will be mailed gratis upon request to all applicants.

**Neustadt Automobile and Supply Company, St. Louis.**—This firm's mailing representative for 1908 is a book of 188 pages, of large size, bound in yellow covers, with a bright red band across the center, on which the firm's name is printed. Above this is the title, "The Growing House," as, in addition to the headquarters at 3948-3954 Olive street, St. Louis, a branch house has been established at 368 Golden Gate avenue, San Francisco, to take care of the Coast trade. The book itself is replete with a most complete showing of running gears, motors, transmissions, parts and accessories, all of which are of well-known standard makes. In fact, there is everything for the automobile and motorboat that can possibly be imagined and that covers a range of articles much wider than the average autoist has any idea of.

**Lozier Motor Company, New York.**—Under the title of "Lozier Logic" the publicity department of this concern has decided to issue a house organ which, as its head-line indicates, will be "published with more or less frequency and always on the square." It is an attractively made up booklet in small magazine form and is "in the perpetual interest of the Lozier motor car," after which it is hardly necessary to add that it is filled with Lozier, first, last and all the time, but so interestingly presented that the reader forgets he is reading a periodical catalogue. The frontispiece shows the "Peerless One," W. J. Bryan, in a Lozier, while the remaining twenty pages are generously interspersed with attractive illustrations showing Lozier cars in recent events and competitions.

**Haynes Automobile Company, Kokomo, Ind.**—It is one thing to compile a catalogue and quite another to make it a piece of interesting reading, though it is evident at a glance that this object has been attained in the case of the new pamphlet just received from the makers of the Haynes cars. The Haynes Company is, by the way, now entering upon the fourteenth year of its manufacturing career, so that the preliminary "argument" which prefaces the story of the 1908 Haynes cars is well worth reading. The booklet deals briefly with each salient feature of the Haynes design and construction, the parts being attractively illustrated. In fact, the whole catalogue is a business-like presentation of the maker's claims for superiority that is well-dressed typographically.

**Jackson Automobile Company, Jackson, Mich.**—"Jackson motor cars need no introduction to the public," say the makers, "as this is their seventh season." Accordingly they confine themselves to a brief description with a single illustration of each model, the catalogue being prefaced with an attractive frontispiece showing a landscape in col-

ors, a Jackson car at full speed occupying the foreground. Following the brief descriptions of each model for the coming season, which are accompanied by half-tone illustrations and set off by attractive headpieces in colors, there are two pages of views of the mechanism of the cars, three pages of the "Winnings of Jackson Cars," some testimonial letters and a page of illustrations of the various trophies won.

**Haschke Storage Battery Company, Chicago.**—"Facts—Real, Certain, Undeniable Facts, Concerning the Haschke Storage Battery," is the title of the opening page of a booklet being sent out by these makers of accumulators for light, power and automobile use. The pamphlet is only one of 16 pages and cover, but within its covers, the front one of which bears the significant quotation "fool proof," is condensed a great deal of information about the Haschke storage batteries. Nor is it all balled down facts, as the text matter is relieved by occasional half-tone illustrations showing the application of the batteries.

**Mora Motor Car Company, Newark, N. Y.**—In presenting its trade literature to the automobile-buying public for the coming season this concern goes into the why and whereof of the "Six vs. Four" problem and shows why it was convinced that the additional cylinders were an advantage, although the Mora four for 1907 was an unusually successful car. The catalogue attractively illustrates and describes each different type turned out, as well as a large number of the essential parts of construction, showing their design.

**Goodyear Tire and Rubber Company, Akron, O.**—Under the title of the query, "Are You Getting Your Share?" this company is sending out an interesting little sketch written in the vernacular and describing the experience and views of the driver who did not have Goodyear equipment, with those of a second chauffeur who stops to see if any assistance is required by the man who is struggling with a tire that has given up its life for the time being.

**American Gasoline Motor Company, Baldwinville, N. Y.**—This firm makes a specialty of supplying castings and machined parts of two-cycle motors to be built by their customers, and is sending out a pamphlet describing the various types and sizes offered, as well as the numerous accessories necessary to build the complete motor and install it in a boat, the motors being of the marine type.

**Pope Motor Car Company, Toledo, O.**—The distinguishing features of Pope-Toledo automobiles are well presented in the firm's 1908 catalogue just received. Three large illustrations of the Pope-Toledo touring car, limousine and runabout give an excellent idea of the company's lines. The get-up of the catalogue is of the highest class.

**Hatfield Motor Vehicle Co., Miamisburg, O.**—What can be obtained for an expenditure of a little over half a hundred dollars is attractively put forth in the 1908 Hatfield Buggyabout catalogue. The high-wheeler has its features well backed up in the catalogue and is thoroughly illustrated in detail and as a unit.

**The Angler Company, Boston.**—Very little that is in any way connected with automobile equipment has been omitted from the 1908 supply catalogue of the Angler Company, Boston. Everything from cotter pins to magnetos is described, illustrated and priced in the New England publication.

**Northwestern Storage Battery Co., Milwaukee, Wis.**—Storage batteries for automobile use and illuminating purposes receive the major portion of attention in this firm's recently published catalogue. Other lines handled and described are charging outfits, electric lamps and electric searchlights.

**Moon Motor Car Company, St. Louis, Mo.**—"Simplicity" is taken as the keynote of the Moon automobile, described in the 1908 catalogue. To show how the car excels in this respect numerous illustrations are given of various parts of the engine and transmission.

**Pope Manufacturing Co., Hartford, Conn.**—"Held High in Public Esteem" is how the testimonial handbook of the Pope-Hartford is presented. Usual methods of catalogue compiling have been departed from in this work, with very pleasing effect.

**The Bartholomew Co., Peoria, Ill.**—"Why I Bought the Gilde" is a satisfied customer's account of the reasons which induced him to invest in the machine from Peoria. The story is told in a little booklet printed in colors.

**Motor Car Equipment Co., New York.**—Two thousand articles are illustrated, described and priced in the 1908 catalogue of the Motor Car Equipment Company, Warren street, New York.

INFORMATION FOR AUTO USERS

**Diamond Repair Block.**—This has just been placed on the market by the Diamond Chain & Manufacturing Company, Indianapolis, Ind., and it has proved so successful that it promises to make a riveted chain easier to repair than one of the detachable type. It is smaller than any tool ever

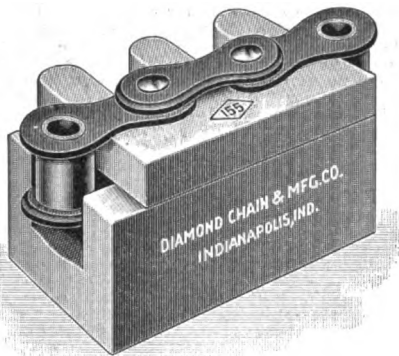

THE NEW DIAMOND REPAIR BLOCK.

brought out for the purpose and takes up but a very little space in the tool kit. By placing the chain in the block as shown in the illustration, and giving both rivet heads a light tap with the hammer, the side bar may be lifted and the repair link inserted, making the chain ready for use again in a minute or two, while the whole operation of taking the chain off, repairing it and putting it back again need not take more than ten minutes. If it is desirable to use the old link again, it is only necessary to put the link and side bar back into place and flatten out the two rivet ends with a hammer. It is a speedy means of repair that will be appreciated by owners of chain driven machines.

**Time Saver Tire Plug.**—This is a novelty recently placed on the market by the Auto Time Saver Repair Kit Company, 178 Devonshire street, Boston, Mass. With its aid it is possible to repair inner tubes



TIME SAVER PLUG.

permanently without the aid of vulcanizing apparatus, rubber patches, or cement. It consists of the rubber plug shown, which is first inserted in the puncture, and then firmly compressed by means of a pair of pliers as shown in the cut illustrating the operation. This grips the rubber around the hole and closes the puncture permanently. The Time Saver plugs are made of two circular brass discs, joined by a

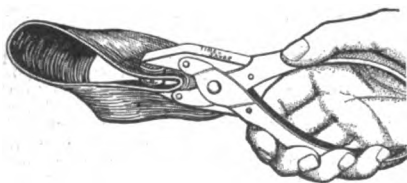

TIME SAVER PLIERS IN USE.

solid post 3-16-inch long. The discs are grooved, so that when clamped together, they hold the rubber securely. The solid post does not collapse, but remains intact, furnishing ample support for the pressure of the discs against the rubber so that there is no possibility of the discs becoming separated. The entire plug, being rubber-covered, presents a surface similar to

that of the inner tube. The special Time Saver pliers used for the operation, have circular washers attached to the jaws, the lower washer being perfectly flat so that it cannot cut the rubber, while the upper washer is made convex. The Thomas car in the New York-Paris run has been supplied with Time Saver plugs.

**Monster Gasoline Gages.**—One of the most striking accessory exhibits at the recent Boston show, was that of the Boston Auto Gage Company, which exhibited some monster gasoline gages, 11 feet in length, made especially to the order of a large dyeing and cleansing establishment in Philadelphia. The gage is known as the Triumph, and that its success is already a well-established fact is quite evident from its adoption by no less than eleven different manufacturers of high-grade American cars, on which it will be regularly included as a part of the stock equipment. The "Detachable Second" gage, which is used by the George N. Pierce Company, Buffalo, N. Y., on all the 1908 Pierce Arrow cars, is another one of the products of the Boston Auto Gage Company, and its presence on a car is highly appreciated by an owner or driver.

**Universal Tire Protector.**—Briefly described, this is an armored sleeve with a positive mechanical anchorage, which is being placed on the market by the Universal



UNIVERSAL TIRE PROTECTOR AND ANCHOR.

Tire Protector Company, Angola, Ind. The inventor of the Universal, having experienced the forms of tire trouble common to all autoists, has endeavored to bring out a combination having a positive mechanical anchorage, that shall be practically instantaneous in application, adjustment and removal, unyielding to the hardest usage, and universal in its application to all makes and sizes of tires, shapes of felloe and rim construction. It has only been after putting it to the most severe practical tests that it has been put on the market. The Universal Tire Protector is made of chrome leather specially selected for this purpose, and is equipped with a reinforced steel armored tread of special construction. Patent steel draft hooks and side plates produce perfect conformity to the shape of the tire. There are no lacings nor buckles, and only one small wrench is necessary to attach or release the fastening which holds the Universal where it is put, the operation requiring but a very short time.

**Gre-Solvent.**—Ever get your hands grimy? Every man who takes care of his car or motorboat, and what owner does not prefer to do so when he has the opportunity, cannot fail to get a liberal coating of grime and grease on his hands, and it is of the kind that resists all attempts

to remove it in the ordinary manner. For several years Gre-solvent, which is "miles ahead of soap," has been the friend of the man whose hands have become soiled through working around machinery. The quality of this cleanser has always been of the best, and this year, the manufacturers—the Utility Company, 332 Broadway, New York—have increased the size of the package, giving a much greater quantity without increasing the price or lowering the quality.

**Quick Tire Wrench.**—Any autoist who has tried to take off the lugs of a clincher tire in a hurry realizes that the process is one in which quick time cannot be made with the appliances ordinarily used for the purpose. To make this possible, John Kelly,



THE QUICK TIRE WRENCH.

Congress street and Forty-sixth avenue, Chicago, has brought out what he terms the "Quick Tire Wrench," which is illustrated by the accompanying line cut. It is an ingenious little device designed to be slipped over the lug cap until it engages the square part of the shank of the lug. By having the string wound up left-handed, the lug may be removed by a single pull, while to reseat it, the string is wound in the opposite direction. The maker claims that it is possible to save half the time in tire changing with the aid of the Quick Tire Wrench. It is made in three sizes, 1-2-inch, 5-8-inch and 9-16-inch.

**Ideal Automobile Switch.**—More batteries and coils have been condemned as the result of a poor switch than the recording angel could possibly take account of. The ordinary types of switches in common use when the automobile came upon the scene were not adapted to its use owing to the vibration and hard service to which they were put. Between constant shaking and the presence of dirt and grease they did not give a satisfactory contact for very long. To overcome these defects the Ideal

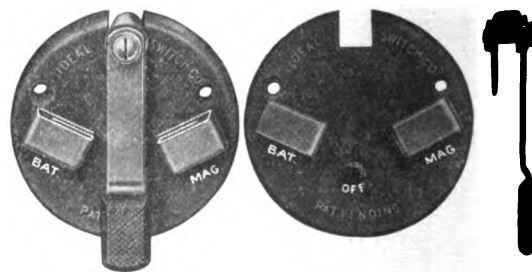

IDEAL AUTOMOBILE SWITCH AND PARTS.

Switch Company Inc. Plainville, Conn., brought out the type shown in the accompanying illustration. The blade is removable for safety and when in position gives a positive and clean contact; it cannot jar out of place owing to the construction of the spring contact posts which are self-locking. With the blade in the vertical position as illustrated, the switch is in the off position while turning to the right, or left, gives the magneto or battery connection, as desired.

# THE AUTOMOBILE

## NEW YORK-PHILADELPHIA—MINUS JERSEY TRIBUTE

By PATHFINDER.

CONTINUED inhospitable attitude of the New Jersey authorities toward automobilists, as evidenced by the recent passage of amendments to the existing motor vehicle law, making it still more drastic and unreasonable in its provisions, will result in the renewed decision on the part of many tourists to avoid that State altogether. Nevertheless, tourists are by no means desirous of discontinuing their trips to Philadelphia, or to the many places of interest lying to the south and west of that city, such as Baltimore, Washington, Gettysburg, the Shenandoah Valley, and the National Highway. It is obvious that the solution of this problem lies in making the trip between New York and Philadelphia without entering the State of New Jersey. That such a trip is possible, is evident by a glance at the map accompanying this article. But the desirability of such a route, the mileage, and other features, were matters which could only be determined by an actual tour of exploration.

I have had no little curiosity regarding the possibility of getting along without a New Jersey license of the 1908 model, and, accordingly, last week determined to make the trip to Philadelphia without entering the hostile borders of that Commonwealth, even if I spent a week in the task.

Leaving New York in our 30-horsepower White steamer, we first proceeded to Tarrytown. Here we were ferried across to Nyack, on the opposite shore of the Hudson. This is the only ferry on the new route, and should be compared with three ferries on the Staten Island-Trenton-Camden route, and two ferries on the route via Newark. The ferry at Tarrytown, it should be remarked, runs on practically an hourly schedule. Tourists starting from New York in the morning should make connections with the boat that leaves at 10:10 or at 11:10. The fare for car and passengers is \$1, and the ride is a pleasant one. From Nyack, we continued almost due west to Suffern, and



Typical Country Road Leading to Richmond, Penn.—One of the Many Picturesque Stretches of the Route.





Picturesque Waterfall at "The Gap."

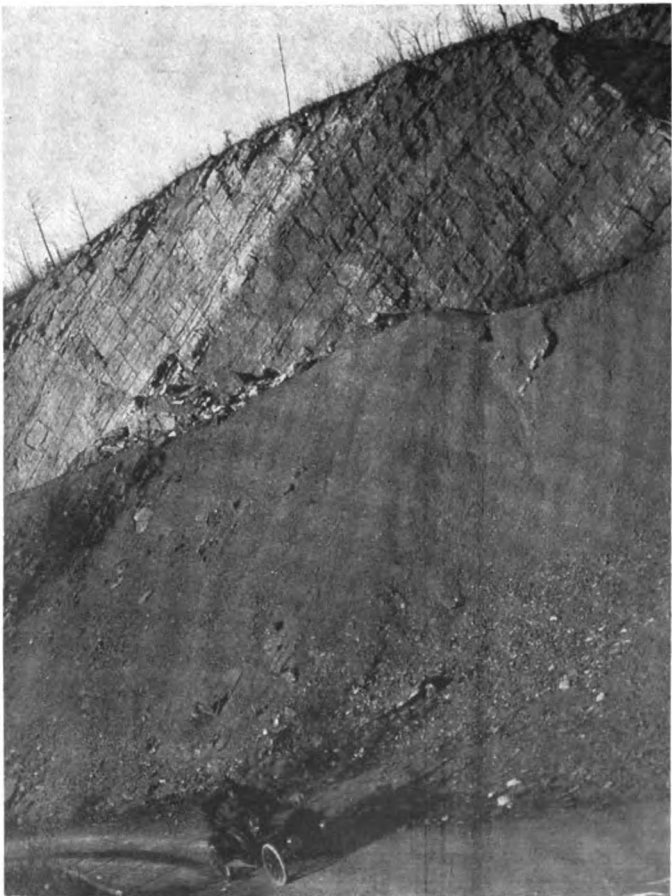

Seen on the Road Leading to Port Jervis.

here we struck the main route, which leads northward from Jersey City to Newburgh and other points on the west of the Hudson river. We followed this route through the beautiful Ramapo valley, passing Tuxedo and Southfield, and then proceeded over "Harriman's private road" through Arden to Turner. Here we turned off from the main north-and-south route, and struck out toward the west. The splendid roads which we had hitherto encountered continued without interruption, and we made quick time through Chester and Goshen to Middletown, this part of the route leading through a delightful rolling farming country.

We had anticipated that on the next stage of the journey we would have some very bad roads, particularly in view of the recent heavy rains. Just beyond Middletown we inquired of a lady what kind of a road we would have to Otisville, the next town.

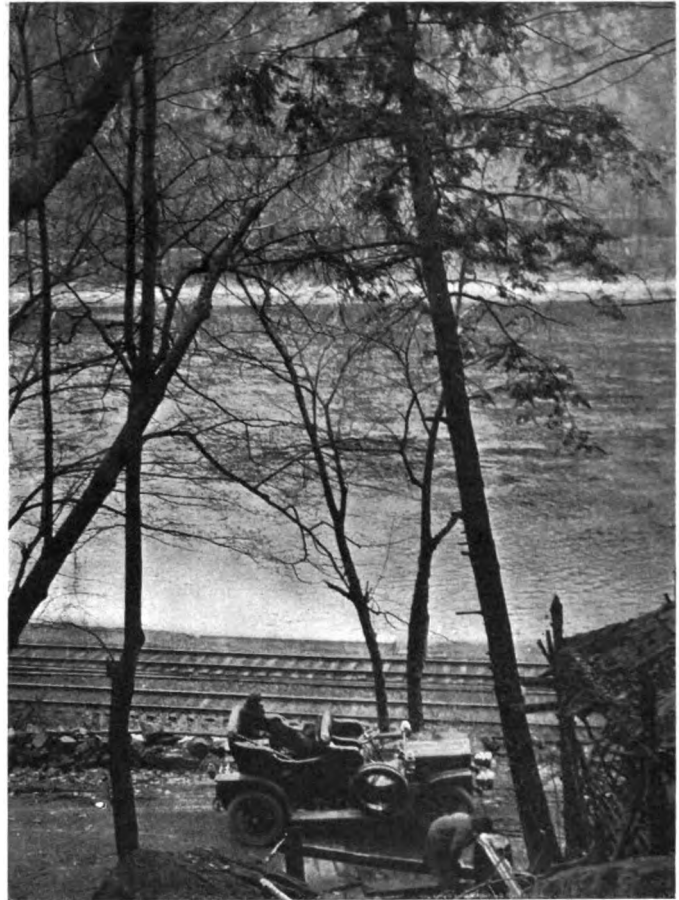

White Steamer at the Famous Delaware Water Gap.

"It is a lovely road," she answered, and "lovely" it proved to be—smooth, hard, well drained, and in every respect ideal. At the next little hamlet, Huguenot, we stopped a moment to exchange greetings with the postmaster. "Fine roads you have around here," we exclaimed. "Well," he replied, cautiously, "they will be when we get all the stones raked off." Such commendable fussiness! We had not noticed that there were any stones on the road. No wonder that there are good roads in that section! They are not State roads, by the way, but have been built and are kept in repair by the local communities.

The fine roads continued, and we drove into Port Jervis over as fine a straightaway as any racing driver could wish for. We did not see any hotel at Port Jervis which looked attractive, and, therefore, we kept on our way. We crossed the iron toll bridge over the Delaware river into Matamoras, in the State of Pennsylvania. Then commenced our ride down the valley of the Delaware. I doubt if more beautiful scenery can be found in any section so near to New York, barring, of course, the Hudson river scenery. On one side of the road, the Delaware river

flows lazily on its way, sometimes close to the road, sometimes a half mile away. On the other side of the road rise towering cliffs, strongly suggestive of the Palisades and doubtless of the same geologic origin. Far on the left may be seen the inhospitable hills of New Jersey. All things considered, the scenery is decidedly distinctive.

Eight miles below Port Jervis we came to the town of Milford, and here we decided to spend the night at the very comfortable Milford Inn, which is one of the large number of summer hotels for which the place is distinguished. Milford, by the route which we followed, is 104 miles from New York. We had crossed the Tarrytown ferry at 11:10, had stopped off an hour for luncheon and frequently for short intervals in order to inquire our way, yet we were at Milford before 6 o'clock. It is thus evident that the roads are of a kind which permits rapid traveling.

Starting from Milford the next morning our route again lay along the Delaware river, the scenery being much the same as that between Port Jervis and Milford and the road almost equally good. However, there are numerous sharp turns on the narrow road, suggesting cautious driving and the frequent tooting of the horn. Thirty-three miles below Milford we reached the famous Delaware Water Gap. I will not attempt to describe this great natural curiosity. All travelers by the "Road of Anthracite" await expectantly for the fitting view which can be obtained from the car windows—and then when they return home they declare that they have seen "The Gap." To all those people, to Phoebe Snow and her fellow-travelers, I say, "Go to 'The Gap' in an automobile, as we did, and drive through it close to the water's edge, stopping at each bend in the road to take in the wonderful vista, and then—and not until then—you may truthfully report that you have seen 'The Gap.'"

Five miles below "The Gap," at the town of Portland, the road leaves the river and then come ten miles of road which are distinguished by water-breaks, the first seen on the trip. At Martin's Creek the road again comes back to the river edge, and there is a fine eight-mile stretch of macadam into Easton. South of Easton there is a stretch of about twelve miles where the road again follows the Delaware river. Then the road again bears inland. On either side of the town of Ottsville we encountered some very rough roads, which are still in much the same condition as they were on the first of January, when twenty-two of twenty-eight touring cars competing in the Quaker City Motor Club endurance run failed to maintain a schedule of twenty miles an hour over this section of road. As we neared Doylestown the good roads began again, and thereafter we had a fine macadam highway through Hatboro, Willow Grove and Jenkintown into Philadelphia, entering the city by the way of the York road and North Broad street.



Beautiful Country Near Turner, Miles of Which Abound.

The total mileage to Philadelphia is 225 miles, the easiest kind of a two-day trip, and infinitely more interesting and varied than the usual one-day trip across the State of New Jersey. Moreover, the tourist who follows our route has the satisfaction of knowing that he has signed the new Declaration of Independence—independence of a State in which, on June 1 next, there goes into more costly effect a motor vehicle law which outrages the sense of justice of those tourists who ask for nothing more, and who are satisfied with nothing else than a square deal in the use of the public highways.

It will be remembered that one of the most notable clashes which ever took place between the advocates of sane motor vehicle laws and those who favor radical restrictions occurred at the banquet of the New Jersey Automobile Club in Newark last February. The leader of the progressives was Judge Hotchkiss, president of the A. A. A., while on the other side were arrayed Governor Fort and Senator Frelinghuysen. Judge Hotchkiss argued for the recognition of licenses granted in other states, and he ridiculed in masterful fashion the power-of-attor-

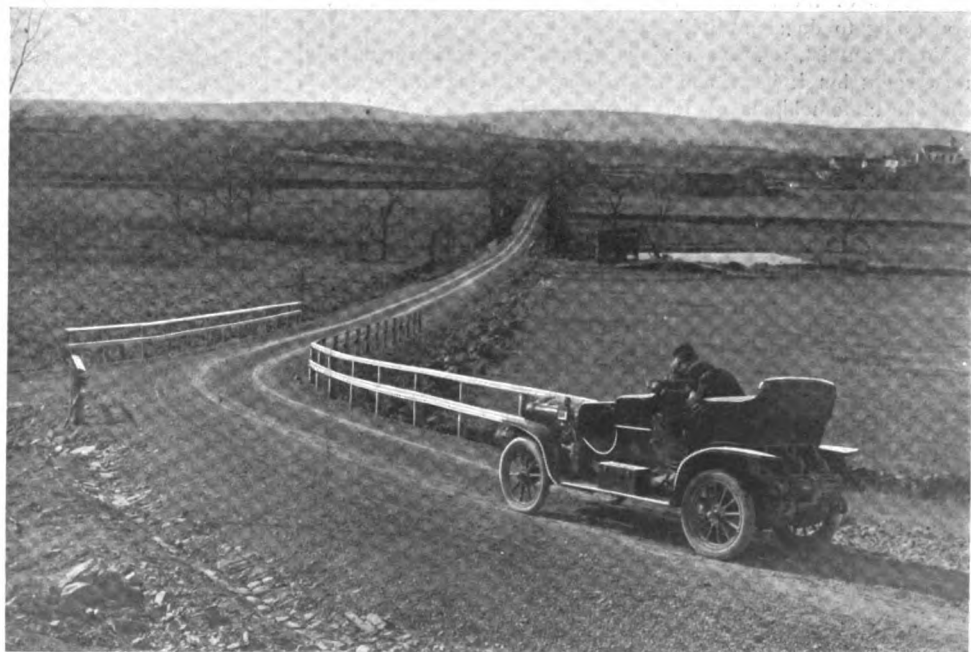

Fine Road to Middletown Stretches Away In the Distance.



Crossing Old-fashioned Canal Bridge.

ney clause and other obnoxious features of the bill which has since become a law. The New Jersey officials took the ground that their state, being located between two great centers of population, was entitled to heavy tribute from those who used the roads in traveling between New York and Philadelphia, and they intimated that, no matter how vigorously automobilists might denounce the law, they would nevertheless have no way of avoiding contribution to the State treasury, or of escaping the other



Conveniently Located Prison in Fashionable Milford, Pa.

provisions of the law. It was the old question of "What are you going to do about it?"

To the autoist, resident in New Jersey, there is, unfortunately, no escape; but it is evident from what has been written above that the automobilists of Philadelphia and of New York who, under the present statute, contribute such a large share of the license fees collected in New Jersey, will be able to omit the State altogether from their touring calculations. There is no



Following the Beautiful Delaware River.

doubt that a decreased revenue from the automobilists, when an increase is anticipated, will be a much more potent argument with the State authorities at next year's session of the legislature than would any plea based on justice or on reason.

If the route which I have described above led over bad roads or into a country not well supplied with hotel accommodations, I might hesitate to recommend it as a substitute for the usual New Jersey route. But the attractiveness of the new route is such that, even were all questions of State laws laid aside, I would recommend it as one of the best two-day trips leading from New York or from Philadelphia.

**ADVERSE DECISION IN INDIANAPOLIS.**

INDIANAPOLIS, IND., April 20.—Judge Henry Clay Allen of the Marion County Circuit Court has decided that the city automobile ordinance, which has been in force for several years, and which provides an annual license fee of \$3, is valid and does not conflict with the State law. Unless the case is carried to the

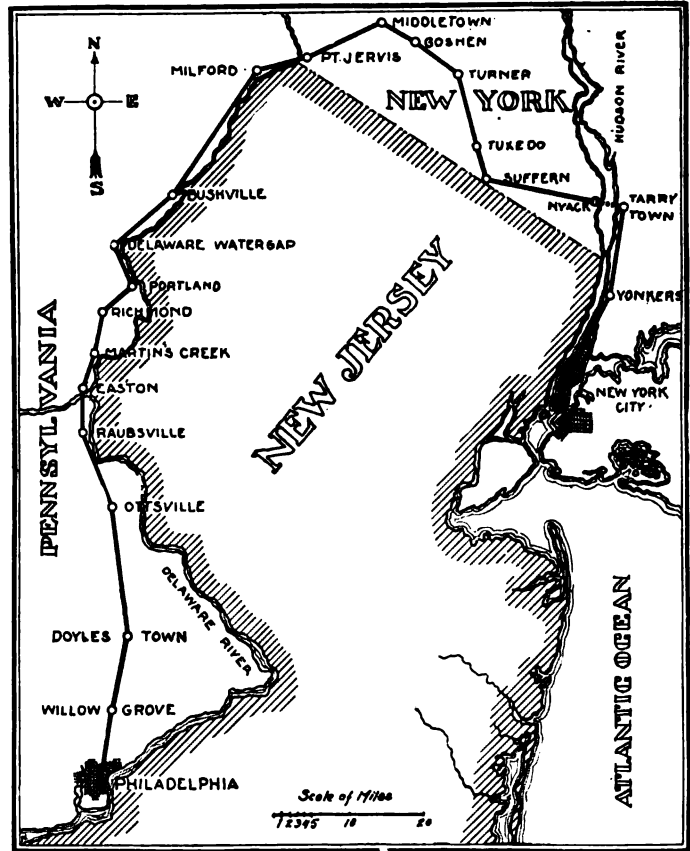

How to Avoid Going Through Darkest Jersey.

Supreme Court, which has not yet been decided upon, this closes a case which has been fought hard for almost one year.

Judge Allen holds that the ordinance does not conflict with the State law, as the former is for revenue purposes only, while the State law is a police regulation. Some 900 owners have been waiting to pay their 1908 license, and City Controller Breunig announces this fee must be paid at once or arrests will follow.

**OHIO'S UNIFORM LAW HAS GOOD CHANCE.**

CLEVELAND, April 20.—Although for a time it appeared as though the Motor Vehicle bill introduced into the Ohio Legislature was doomed to die an untimely death, there now seems a chance for it to pull through, after all, even though amended somewhat. Secretary Forbes of the Cleveland Automobile Club is spending some time in the capital city these days in an effort to advance the measure, and he writes that he has a fair chance of being successful.



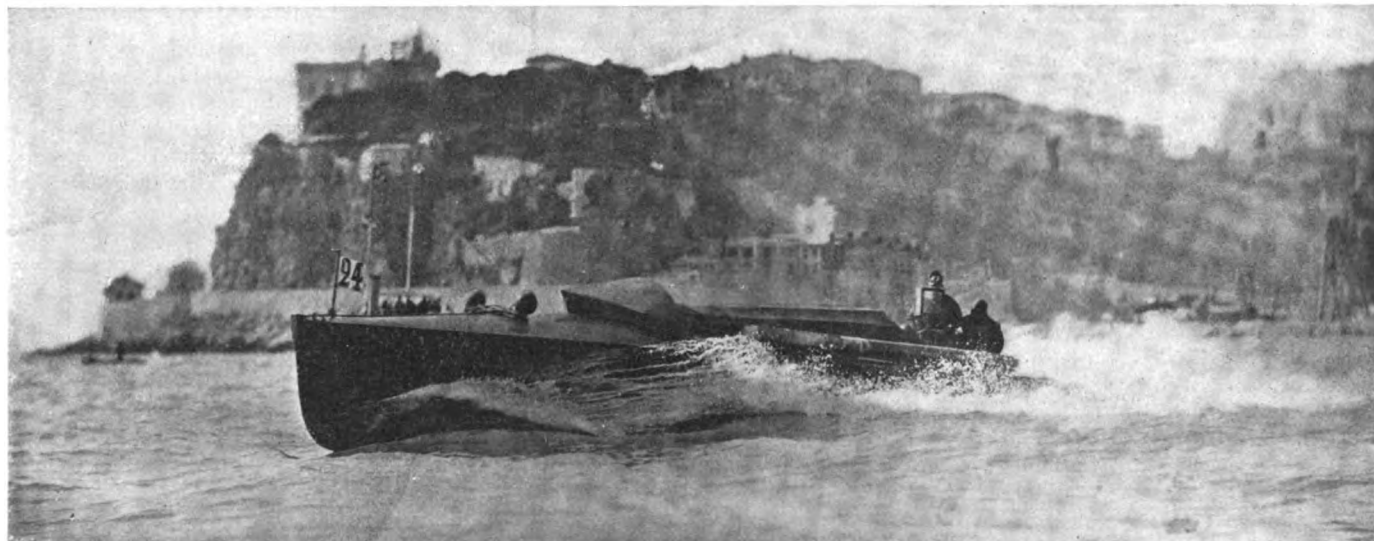

Comte de Vogue's "Panhard-Levassor," Winner of the Championship of the Sea, at Monaco, with Average Speed of 33 1-3 Miles per Hour.

## STORY OF MONACO'S ANNUAL AUTO-BOATING CARNIVAL

MONACO, April 16.—Every year some one event stands out at the Monaco motor boat meet overshadowing all others by its importance. The fifth annual meeting, organized by the International Sporting Club of Monaco, with a prize list of \$20,000, may be taken as an exception, in view of the fact that, instead of one, there were three conspicuous happenings. The Britishers won a victory over France and Italy by the remarkable performance of the *Wolseley-Siddeley*, the powerful racer specially built to wrest speed honors from the American *Dixie*; Italy suffered the loss of the *Fiat-Gallinari*, destroyed in a few brief seconds by fire; and France obtained her revenge over the Union Jack by winning the Championship of the Sea, distance 124 miles, at an average speed of 33.13 miles an hour.

Britain scored her substantial victory the second day of the meeting in a 50-kilometer race for boats of unlimited power. In a calm sea, the English boat covered the distance in 51:17, being an average of 33.28 miles an hour, beating *Panhard-Levassor* by nearly seven minutes and completely walking away from the Italian *Jeanette*, the *Lorraine*, and Brasier's *Grand Trefle*.

On the start being given, *Panhard-Levassor*, piloted by Comte Robert de Vogue, got away first, followed by the English *Wolseley-Siddeley*, the *Lorraine*, and the *Jeanette*, Vincenzo Florio's boat, engined by Itala. The *Grand-Trefle*, Brasier's craft, having been in collision a few hours before, only got away a minute and a half after the others had left. During the first round, the French and English boat raced neck and neck, rounding the home buoy close together, amid intense excitement. Gradually, the Britisher forged ahead, and at the end of the second round was fully 200 yards ahead of the *Panhard-Levassor*. The lead was gradually increased, Britisher and Frenchman running with perfect regularity, until at the end of the eighth round the *Wolseley-Siddeley* had a lead of 2 minutes 13 seconds on its rival. The *Jeanette* went through to the end, finishing rather more than four minutes behind the winner. The *Lorraine* abandoned during the fifth round, and the *Grand-Trefle*, with her three Brasier motors, went out of business before the end of the fourth round.

Particular interest attaches to the *Wolseley-Siddeley*, from the fact that she has been built by Saunders and engined by the Wolseley Company with the express purpose of regaining the international cup, now held by the American *Dixie*. The boat is 39 feet 4 inches over all, 6 feet beam, and has a maximum draught of 32 inches. Her power plant consists of a couple of eight-cylinder engines, rated at 200-horsepower each. The makers, however, refuse to announce the bore and stroke. The two motors are mounted side by side with a slight outward list, in order to give a little more room for the movement of the

mechanics. The cylinders are cast in pairs, each pair being fitted with a very light screwed-on copper jacket. Valves are all on the inside, and do not present any particularly interesting feature, with the exception of the welded steel water space over each water cap. The eight-throw crankshaft, with bearings between each pair of cylinders, and cranks of one group of four set 90 degrees ahead of the other group, is a remarkable piece of work. The centrifugal pumps on the forward end of each motor assure a circulation of cooling water, the exhaust pipes being water-jacketed near the engine, then carried aft into a 6-inch pipe, finally branching into two mufflers.

Ignition is provided by high-tension magnetos, completely encased at the forward end of the motor; high-tension coils are fitted as a stand-by in starting up. Total weight of each engine is 1,670 pounds. On the testing apparatus 207-horsepower was obtained from each motor at an engine speed of 1,000 revolutions per minute.

### Championship of the Sea Won Thrice by Panhard.

Twenty-one boats, racers and cruisers, started in the Championship of the Sea, run over a distance of 200 kilometers, the fifth day of the meeting. On a perfectly calm sea, the *Panhard-Levassor*, *Rapier III.*, *Wolseley-Siddeley*, *Scarlet-Runner*, *Grand-Trefle*, *Labor*, *Lorraine*, *S. I. A. M.*, *Louis-René*, *Essembi*, *Mais-Je-Vais-Quand-Meme*, *Isabelle-Gnome*, *Lorraine IV.*, *Delahaye-Nautilus*, *Mors-Ulysse*, *Sec*, *Lolotte*, *Leman*, *Ricochet XVI.*, *Jeanette*, and *Mors-Calypto* got away in fairly regular order.



The "Wolseley-Siddeley" that Won the 50-kilometer Race.



At the outset *Panhard-Levassor*, *Rapriere*, *Wolseley-Siddeley*, and *Grand-Trefle* were looked upon as the boats that would set the pace. The British *Wolseley-Siddeley*, however, had to abandon almost at the start, owing to difficulties with the clutch of the port engine. The Italian *Jeanette*, which Vincenzo Florio was piloting, refused to be started up, and it was not until the first boat had a lead of 37 minutes that the amateur sportsman went away, determined to go through despite his handicap. The *Panhard* boat very early took a lead, and got so far ahead of the others that its position was secure from the first.

Brasier's *Grand-Trefle* and the little *Rapriere*, fitted with *Panhard* engines, supplied the sport in the fourth round. For four consecutive rounds the two French boats made a neck-and-neck race, the *Grand-Trefle* cutting sharp round the buoys and gaining at something each turn, only to lose it on the straight. The close struggle, watched with tremendous excitement by the mass of spectators on the terrace, came to an end by the *Grand-Trefle* shipping too much water, becoming heavier, and falling off in speed. The little *Rapriere* then forged ahead, while the *Grand-Trefle*, after covering two-thirds of the distance, ran for port.

Vincenzo Florio's boat, which had started out with the loss of half an hour, now found itself fifth, the boats ahead of it being *Panhard-Levassor*, *Rapriere*, *Delahaye-Nautilus*, and *Calypto*. The two latter, however, were only fast cruisers, and it was not long before the Italian had left them astern. Then one of those chances which are always to be looked for in a race allowed it to rush in and secure second position. The *Rapriere*, which is certainly a faster boat than the two-year-old Italian, had an irreparable accident to its machinery and had to be towed home. There was no further doubt as to the result of the race; Comte de Vogue piloted his boat past the winning post amid enthusiasm—for it is the third time the amateur pilot has won the Championship of the Sea—in 3:46.2, equal to an average speed of 33.13 miles an hour.

*Panhard-Levassor*, which because of its performance at Monaco without any preliminary tuning up worthy of the name, can claim to be of, if not the, fastest motorboat afloat, is fitted with four 120-horsepower 4-cylinder engines of about 7 1-2-inch bore, driving twin propellers. The lines of the hull are very closely modeled on those of last year's successful *Panhard* racer.

The last three days of the meeting were given up to handicaps, and the last event of all was a keenly contested struggle between France and Britain, in which the former was victorious. This last day stands out as the most important one of the whole meet. It began with matches between racers and cruisers of the different series having qualified in the long distance events.

After some finals for cruisers, of little international interest, *Panhard-Levassor*, *Wolseley-Siddeley*, *Delahaye-Nautilus*, and *Rapriere* lined up for the last and most interesting race of the meet, the standing mile and flying kilometer. One after the other, the balls dropped down the pole, and almost before the last one had reached the end of its course the British *Wolseley-Siddeley*, splendidly handled, had shot over the line and gained a few yards on its rival. It was a dead heat at the mile post. As the second post was passed, the Frenchman had got well ahead, the difference in time between the two fastest boats Europe has produced this season being 2 2-5 seconds. At an average speed of 34.67 miles an hour, the *Panhard-Levassor* had won the last Monaco race, and proved itself a faster boat than the one built by England with a view of capturing the International Cup, now held by *Dixie*. Tabulated, the result of the mile and kilometer record is as follows:

<i>Panhard-Levassor</i> .....	2:01 1-5	1:02 4-5	3:04
<i>Wolseley-Siddeley</i> .....	2:01 1-5	1:05 1-5	3:06 2-5
<i>Delahaye-Nautilus</i> .....	2:20	1:14 1-5	3:34 1-5
<i>Rapriere</i> .....	2:20 2-5	Disabled	

At the international nautical conference, which will be held in May, one of the most important subjects to be taken up is the creation of an international cup, somewhat on the lines of the Gordon Bennett cup, to be competed for annually by three or four boats per nation.

## DELAGRANGE CHAMPION FLYER.

PARIS, April 15.—Leon Delagrangé has gone ahead of his friend, Henry Farman, by carrying the world's flying record to 2.43 miles in 6 minutes 43 seconds. It was a magnificent performance, witnessed by a small number of spectators on the Issy-les-Molineaux military ground, in the calm of last Saturday evening. Officials of the Aero Club marked out a triangular course by means of three flags. Circle after circle was described around the three fluttering yellow flags, the minutes lengthening out until 9:15 had been recorded by the timekeeper, at which moment the aeroplane gradually came to earth with its gasoline and water supply exhausted. Multiplying the dimensions of the triangle by the number of rounds made, Delagrangé's distance was 3.46 miles. On the first two rounds, however, the machine had slightly touched the ground on two occasions, owing to being too low for the curves, and official recognition was only taken of the distance covered since last leaving earth, which brought the record to 2.43 miles in 6 minutes 30 seconds, the longest distance ever covered under official control by a heavier-than-air flying machine. Farman's record, established March 21, was beaten in distance by 1.19 miles.

### Delagrangé May Visit America.

NEW YORK, April 21.—As the result of the negotiations which are now being carried on by the Chicago Aero Club to have Farman's and Delagrangé's original machines, or duplicates of them, imported for the aeronautical congress to be held in Chicago July 2-4, Albert Triaca, chairman of the Aviation Committee of the Aero Club of America, announced last night at the meeting held at the club headquarters, 12 East Forty-second street, New York, that Delagrangé would probably soon visit this country.

Octave Chanute, the American pioneer in aerial flight, began the discussion of the evening, the subject of which was the raising of \$25,000, to be known as the American Aviation Fund. Peter Cooper Hewitt spoke favorably for the plan, as did also A. M. Herring, who is building a machine for the Government; Lee S. Burrige, Charles M. Manly, W. J. Hammer, Augustus J. Post, and Capt. Thomas S. Baldwin.

### Rules for Michelin Aero Prizes.

PARIS, April 16.—Official regulations have been issued by the Aero Club of France for the two aeronautical prizes offered by the Michelin Brothers and totaling \$52,000. The two events, which are to be known as the Michelin International Cup and the Michelin Grand Prix of \$20,000, will be held under conditions only slightly modified from those first announced:

**Michelin International Cup.**—To become the property for one year of the owner of the flying machine which shall on the evening of the 31st December have covered the longest distance without touching earth. For the present year the distance must not be less than 20 kilometers (12.4 miles), around a circuit of not more than one kilometer, marked out by three or four flags. The winner each year will receive \$4,000 in cash, his club will hold the cup for one year, and the victorious flyer will be given a fac-simile. The winner the eighth year will receive \$4,000, and will retain permanent possession of the cup. If in any year the cup is not won, the prize money will be carried forward and added to that of the succeeding year. For 1909 and following years the distance to be covered will be modified by the committee of the Aero Club of France. Flights may take place in any country having a club connected with the International Aeronautical Federation. Entrance fee is \$20 for each day's attempt.

**Michelin Grand Prix of \$20,000.**—This prize will be given to the owner of the aeroplane which shall, before January 1, 1909, make the following flight with two persons on board: Start from any point in the Seine or Seine-et-Oise department, fly round the Arc de Triomphe at Paris, encircle the Cathedral at Clermont-Ferrand, and descend on the Puy de Dome, 4,806 feet above the level of the sea. Time limit will be six hours, the flight to be controlled by the Aero Club of France.

### Wrights Reported to Have Sold Their Invention.

PARIS, April 16.—According to a report, which is circulating in Paris with considerable persistence, the Wright Brothers have succeeded in selling the secret of their aeroplane to M. Lazare Weiller for the sum of \$100,000.



SAN FRANCISCO, April 15.—When the word was flashed over the wire early on the morning of the first day of April that the Italian racer, the Zust, had left Los Angeles, and was making her way northward, the local Italian clubs and colony in general, the Automobile Club of California, and every enthusiast of the automobile, regardless of nationality, began to make preparations for the reception of the racer and her crew. The Automobile Club of California, through its representative, the writer, immediately set to work preparing a pilot car. Chevalier Rocco, the Italian Consul, and the Italian Touring Club had already appointed Armando Pedrini to carry the welcome, not only of the club, but of every Italian citizen, and to pilot them to this city. By noon, the big tourist car, carrying the Stars and Stripes on one side of her tonneau, and the royal standard of Italy on the other, flying small pennants of the Automobile Club of California at her head, sped down Market street and boarded the ferryboat for Oakland, as the run was made over the same route as that taken days earlier by the American Thomas until San José was reached. Here it was learned that the Zust had left Santa Barbara at 12:20 o'clock, and was on her way over the Coast route. From San José, the search was commenced, down the country road, through Edenvale, San Martin, Morgan Hill, and Madrone, to Gilroy.

#### Down the Picturesque Coast Route to Meet the Zust.

All along the way the flags were cheered, and the heart of many a son of Sunny Italy warmed as the standard of their royalty unfurled to their view. Many were the inquiries as to the time the car would be brought past that way. From Gilroy, the pilot car made its way to Salinas through San Juan, and over the grade so well known to autoists of California, bearing the name of San Juan Grade. The route is one of the most picturesque rides open to the automobile to be found in this part of the State. About a mile from San Juan the gradual rise commences, with small, easy grades at first. The road is fairly good, although it is made rough during each Winter by the vehicles which travel it in the rainy season and leave the imprint of the wheels and the horses' hoofs in the soft adobe mud, which is baked hard when the sun dries it up. Steadily climbing, one may look down into the cañons and valleys far below, which, in the late afternoon, are particularly beautiful in their lights and shadows.

Meanwhile a steady pace upward is kept. Around the side of the hill, with its grassy slope rising on one side high above and falling away on the other side into darksome ravines below, there intrudes occasionally a cold gray rocky bluff, enlivened at intervals by rock-lichen; then, again, it is a dense mass of trees and shrubbery, with every shade of freshest greens and brown, great bunches of wild lilac and honeysuckle, and the wicked, enticing beauty of the poison-oak. Slowly daylight deepened into twilight. The green freshness of the distant hills faded into deep purple, while their tops seemed to touch a sky painted in rosy tints of mauve and pink. A stop was made at the summit to take in and enjoy to the full the beautiful view. On one side lay the culti-

vated Santa Clara valley, with its miniature houses and cattle, resembling a set of Noah's Ark, and on the other the wild beauty of the hills and Upper Salinas valley. The descent was easy, and rapidly made, and it was but little after 7 o'clock when the pilot Tourist reached the garage in Salinas, where the stop was made for the night.

The telegraph wires were immediately put in use, and messages were sent to points along the line to find the travelers. After some little time, the word came that they were at Gaviota, and would spend the night there, and, after making a few repairs in the morning, would proceed northward. The next morning, Paso Robles was communicated with, and it was found that they had not arrived there, so a start was made for that place. From Salinas, the route lay down the Salinas valley, through Gonzales and Soledad, over the foothills of the San Lucia range, and on to Jolon. At Soledad, the message was received from Santa Maria, saying that they had passed through there; so a brisk pace was taken. For several miles the road lies in the bed of the valley, which is at present carpeted with wild flowers and the first shoots of the early crops. The foothills were soon reached, and, after a few small grades, the road leads through a beautiful natural park. The trees and shrubs are set almost symmetrically, on a smooth, green lawn, and, for a number of miles, it looks like the work of a landscape gardener. At Jolon, the telephone was again used, but nothing definite could be learned, and the pilot car and the White steamer, carrying the editor of *L'Italia Daily News* and several members of his staff, which had joined the Tourist at Salinas that morning, started on down the valley. The run was made then to Bradley, and another attempt was made to reach the Zust. This was more successful, as the message came back that they had left Paso Robles, and San Luis Obispo, and were going to try to make Gonzales. It was now about 9 o'clock, and as the Zust had some pretty bad roads to come over before they reached Bradley, where they would meet the pilot car, it was decided that the tired searchers should rest at the little hotel. I offered to stay on watch, and the rest of the party turned in.

#### In the Night Hours the Zust Was Greeted.

Seating himself in the tonneau of the Tourist, wrapped in a great coat, the watchman waited. The night was exceedingly balmy, but quite dark, as the little town lies in a valley, and the stars, although there seemed to be more than the usual number in the sky, shed very little light, and as the hours went past it grew colder and darker, and the silence was almost oppressive. In the distance could be heard the call of a night bird, or the bark of a coyote, or the more familiar one of a dog in some farmyard, but the whole world seemed to be wrapped in a blanket of darkness to sleep. Suddenly the alert ears of the watchman, who had been lost in revery, heard the throb and whirr of an engine, so foreign to the environments in which he sat, which he at first thought was a train passing over the track not far away. Listening more closely, the unmistakable chug-chug of

a motor was distinguishable, and his experienced ears knew it was the motor of a foreign make. The road lay around a bend, and soon the lights of the powerful lamps flashed, and he shouted, "All hands on deck!" In a moment the little hotel was alive, and the members of the party gathered, as the big travel-stained car, with her dusty, weary crew answered the shout of welcome. As the night was so far advanced, it being then about 1 o'clock, the racers decided to rest until morning, and, after much congratulation and many questions answered, the party again rested.

#### Enthusiastic Receptions at Every Hamlet.

At 4 o'clock the call was given to arise, and, after breakfasting and a minor repair made to the big *Zust*, the return run was begun. The morning was very cold, a heavy frost laying over everything, and, before starting, it was found advisable to take the cushions of the automobiles into the living-room of the little hotel and thaw them out. Back over the same route as was taken by the searching party on their way down, the Tourist led the big *Zust*. At every farmhouse, every roadhouse and every town, the little groups had gathered to greet the racers and to shout *bon voyage* to them as they sped past. At Soledad, a short stop of half or three-quarters of an hour was made for luncheon, and then the trip was continued. About a mile out of Salinas, the first car from San Francisco joined the procession, and the names of Sirtori and Scarfoglio were cheered, and the automobile fell into the procession. At Salinas, the citizens had gathered in the main street, and quite an ovation was given them here, flowers and Italian colors being thrown into the car. More automobiles joined the parade at this place, and the next relay of the run was made. Near Gilroy, the racer was met by the car of A. P. Giannini, containing Chevalier Rocco, the Italian Consul in this city; G. Pierano, the pioneer Italian of the State, and several other prominent men, and the big Packard fell into line. Gilroy was reached, and another big reception was tendered the heroes here; then to San José.

At this place the United Clubs of Italy gave the crew and the members of the pilot car a banquet, which lasted well into the evening. A number of speeches were made. Some of those who spoke were A. Pedrini, cashier of the Bank of Italy; S. Rocco, and G. Peirano. The remarks of the latter were most impressive, on account of the age of the speaker. Peirano is past eighty, but is still hale and hearty, with the clear Italian eye and a noble-looking head. He spoke to the crew, encouraging them to the end that they were aiming for, telling them to obtain victory, if possible, for the glory of themselves, their country, and their God. The entire party, the crew of the racer, and their friends, remained in San José for the night. The next morning, the last few miles were covered to Oakland, passing through Milpitas, Alviso, Haywards, and San Leandro. At each place more flowers were thrown and flags and bunting waved at the big grey car. The parade by the time it reached Oakland was several blocks long, and, on account of the crowd of cheering spectators, the cars proceeded slowly down Twelfth street to Broadway, and to the Creek boat, which carried them to San Francisco. Here the welcome was scarcely less enthusiastic than that given to the American car, and a cheering mob greeted the car at the ferry. Up Market street to Montgomery, out Montgomery to Montgomery avenue, along Montgomery avenue to Bay, out Bay to Van Ness the line of march lay. This is through the Italian quarter of the city, and every house that boasted a flag had it hanging from the window and waved from the doors or steps. The car was piloted to the St. Francis Garage.

#### Next Came the French De Dion.

Upon receiving word from St. Chaffray, of the French De Dion, that he was in Tulare, and would proceed northward on Monday morning, the 6th of April, over the same route as traveled by the American Thomas, as representative of the Automobile Club of California, I left in the pilot car, Stearns, for Los Baños. The De Dion reached Los Baños early on Tuesday morning, however, as it was necessary for the car to make a big detour

of the usual road between Fresno and Los Baños, on account of the flooding of some of the irrigation ditches. After a very short stop, piloted by the Stearns, the De Dion started for San Francisco.

After leaving Los Baños, the road lies for fifteen miles over rolling ground, and the pilot car had already found that a naturally worn road across fields was the best way to make the distance. This was the route taken, and the French car rolled along at an unusual rate of speed over the fields. Finally, the mouth of the Pacheco Pass was reached, and a little less speed was necessary, as through these valleys and up these mountains the road is very winding, making sharp turns and having steep grades. While on one of the highest and steepest grades, the cars met a team which did not like the appearance of these throbbing monsters, but before any one from the pilot car could reach them, St. Chaffray himself was at their heads, and led them past. This is, no doubt, what has won admiration and good wishes for the De Dion, rumors of which had long since reached California. Seeing several short cuts, the little low Stearns was tempted to take them, although in one or two cases they were exceedingly steep. It was found that the big De Dion was always there and ready to take these, notwithstanding her size and weight. "Old Glory" was everywhere to be seen intermingled with the tri-color of France, which gladdened the hearts of the travelers. All the little towns along the road had their crowd of cheering citizens, but the occupants of the car, as the distance between them and San Francisco grew less, were very impatient to reach the City of the Golden Gate. At San José a stop was made for luncheon, where La France Club had made preparations for a large banquet at the Lamolle House, but St. Chaffray, desiring to make the 4 o'clock ferryboat from Oakland across San Francisco Bay, spent about an hour here, then sped on to this city. When the city was reached, it was found that 160 miles had been traveled by the De Dion in the day. When asked their opinion of the roads they had come over, they stated that they considered that the roads of California were unusually good, and St. Chaffray said that those they had covered in the last day of their trip in California reminded him a great deal of the roads of France. On account of the lack of knowledge of the exact whereabouts of the De Dion and her crew, it had been impossible to make public the arrival of the racer in this city, so that there was no great crowd awaiting her at the ferry. The cars passed up Market street to Sutter, out Sutter to Van Ness, and thence down this avenue to the headquarters of the Renault selling branch, where the car remained until shipped.

The Motobloc has withdrawn from the contest, and will be sold in this city for a comparatively low price.

#### THOMAS CAR LEAVES SEATTLE FOR JAPAN.

SEATTLE, WASH., April 21.—Owing to their inability to have passports viséd by a Russian Consul, the Thomas crew was compelled to forego sailing on the *Glen Logan*, direct to Vladivostok, and left on the *Shawmut* for Yokohama, leaving this afternoon. E. R. Thomas is here to see his car off and made every effort to have the passports in due form, but the nearest Russian Consul is at San Francisco.

For the first time since leaving Buffalo, when the *Zust* had a slight lead, the Thomas finds itself in the rear, the *Zust* and De Dion having left for Japan last week, St. Chaffray being determined to sail, despite the protests of Lieutenant Koeppen and Sirtori that it was an unsportsmanlike thing to do. Sirtori has been re-engaged and he sailed on the *Glen Logan*, together with Lieutenant Koeppen and the Protos, though the latter's driver deserted. The Thomas will run across Japan to Tsuruga, taking a steamer thence to Vladivostok, and as the *Aiku Maru*, carrying the foreigners, was delayed at Victoria, the Americans may overtake them. The chances of the Thomas came near vanishing in the close escape from being wrecked that the *Bertha* had on the trip back to Seattle from Valdez.

## SOME COMMONER FAULTS OF AUTO DESIGN

By A. H. DENISON.

**A** MERICAN manufacturers proudly declare that the design, material and workmanship in their cars is as near perfection as can be reached, yet troubles that may be traced directly to the design are occurring on high-grade and high-priced cars. The essentials of the motor and the transmission system usually have every care lavished on them, and the proper valve and ignition timing obtained by the use of costly and delicate instruments. The utmost attention given to those parts—the motor bearings, valve operating mechanism, etc.—in their design and development in the drafting room will not be of the slightest assistance to the operator who is “stuck” on the road with running gear troubles. Following the rule of tracing troubles from cause to effect, the *apparent* cause may be the loosening of a nut or bolt, or the character of the road being traveled.

The real cause of the trouble is “the work that particular part must perform, also the conditions under which it must labor and still do its work,” had not received sufficient consideration. It seems to be in minor details, where it would seem that particular care or experiment was not needed, occasionally rather important considerations overlooked, that

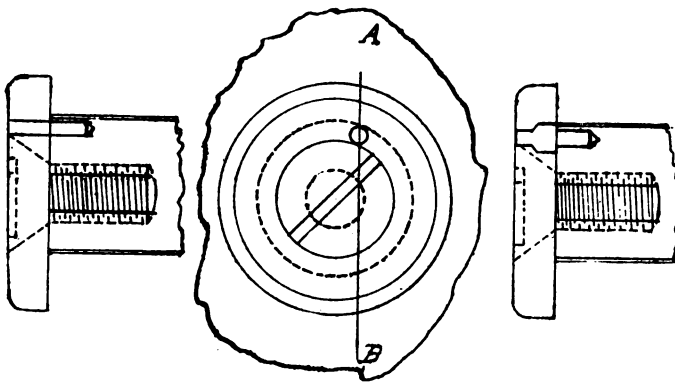

Where a Right-handed Screw Caused Trouble.

causes most of the trouble and expense to the unfortunate owner of that car. Reliability trials are very good in their place, but they would teach a great deal more if the cars entered had a thousand miles to their credit and were taken from their daily work instead of being tuned to the limit in the factory and then handled by the factory experts.

### Some Typical Instances of Faulty Design.

The following are a few instances of where the lack of sufficient consideration in designing the parts referred to has been the cause of trouble. A big car came into the garage one evening and as the motor stopped someone called the operator's attention to a very bad leak in the radiator, the water being emptied in a very short time. An examination of the floor in the rear of the car showed that no water had been lost while the car had been running. The driver declared that he had not struck anything, and the appearance of the front of the car and radiator seemed to bear out his statement. The hood was raised and in the rear a stream of water could be seen issuing from a tube, the radiator being of the honeycomb type. This seemed to indicate that the end of a tube had opened. The radiator, when dismantled later, showed a gash about three-fourths of an inch deep, one inch wide and three inches long. On the motor, coinciding with the gash, was an idler gear driving the water pump and magneto.

The idler ran on a 1-inch shaft, secured to the motor base, and was lubricated with a grease cup. It was held on by a

3-8-inch flathead machine screw and washer about 1-4-inch thick and countersunk to receive the head of the machine screw. To prevent the movement of the idler affecting the screw a small dowel pin was driven into the shaft and the washer drilled to fit over it. (See sketch.) The dowel pin held things for about 2,000 miles. After the radiator was taken off and the front of the motor examined to find the cause of the trouble, the washer was found in the pan directly underneath the idler. It was recognized, the idler examined and both screw and pin were missing. Later the screw was found at the bottom of the pan. The motor, being right-handed, would turn clockwise. The idler, meshing with a gear on the crankshaft, would turn counter-clockwise, and the machine screw, having a right-handed thread, would, when turned counter-clockwise, back out. When the restraining influence of the dowel pin was lost the movement of the gear, carrying with it the washer, soon ran the screw out, though how it had the power of damaging the radiator so much is a question. The radiator was taken to the garage repair shop and though nearly three pounds of solder was put in it it could not be made water-tight and will probably have to be sent to the manufacturer. In putting the washer and screw back the dowel pin was changed so that it will be impossible for it to work out again, as the sketch will show. A thin cast aluminum guard covered the gears usually, but the driver, in order to tighten a troublesome stuffing-box that persisted in leaking unless a cupful of grease was forced into it at regular short intervals, had removed the guard that morning, and, being called in a hurry, had not stopped to replace it, as it was not necessary to the operation of the motor. It may sound very improbable, but, judging from the extent of the damage to the radiator, if the gear guard had been in place it would have been broken and with serious results to the timing gears.

### Unprotected Gasoline Tanks Are Common.

On the following evening, after the same car came in, an odor of gasoline was noticed, and examination revealed a slight leak in the gasoline tank. The tank was built of sheet copper, 1-16 of an inch thick, and without reinforcement to protect the bottom. Slung at the rear of the chassis by two wide straps, almost square in shape, the rear was about 22 inches from the center of the axle. The discharge pipe from the muffler was carried right under the tank and held by a loop riveted to one of the straps, and the end of the pipe projecting about two inches further to the rear. The damage to the tank was directly above the exhaust pipe and the end of the pipe was bent in such a manner as to indicate dropping on an obstruction. The soft copper, offering less resistance than the pipe, suffered most, being bent and torn enough to allow a slight leakage of gasoline, amounting to about thirty drops a minute. The driver remembered dropping into a deep hole that, after dark, was impossible to avoid, and it is extremely probable that the damage was done there. The dangers that an unprotected gasoline tank is subject to in striking stones, collisions in traffic or striking something while reversing is sufficient to cause many manufacturers to place it under the front seat. On this car both exhaust pipe and bottom of the gasoline tank were battered quite a little, showing contact with the ground many times.

All gasoline cars must have a control system and the designer usually has a free hand to work out his own ideas. Simplicity, long life, ease in manufacturing are usually the principal points kept in view. The preeminent consideration should be “safety” and in perfecting the design the ultimate must always be considered. One type of car, equipped with



a sliding gear transmission, did not have a neutral position provided for the control lever. To attain the same result the clutch pedal was provided with a latch, locking it in release position. While working on the car in the garage one day, with the motor running, one of the repair men struck the pedal accidentally, and, one of the speeds being in mesh, the car ran away, though it was caught before any damage was done. Here there must be quite an element of danger in persons getting in or out of the car accidentally striking the pedal, to say nothing of mischievous youngsters who would not hesitate to start a car running away, thus possibly causing a serious accident.

The question may be asked if there are advantages in this system that would make it more desirable or overcome the need of considering the factor of safety. The planetary gear system is more prone to troubles of this nature, yet it has advantages in the fact that were a sliding gear system handled in the same manner as the planetary gear, the gearbox would be ripped to pieces in short order.

#### Steering Gear Defects Are Very Dangerous.

Newspaper reports of serious accidents invariably give the cause as due to the steering gear, though whether the report comes from an expert or the reporter that views the wreck is not told. That steering gear trouble is the most alarming form of trouble that can take place is evident, for if anything else gives way the probability is that the car will be stopped in a very short distance, or at least subject to the control of the operator. If any part of the steering system breaks down all control over the car is lost, and the wheels may be deflected by slight irregularities in the road. The driver, possibly aware that something is wrong, will naturally center his efforts on the useless wheel in front of him. If the steering system is not designed properly and with a thorough comprehension of the conditions under which it must operate, it must be tested daily, and then it is not safe to trust it too much. This does not refer to the proportioning of the material or the composition of the steels used, but to the work in the drafting room. A chain is no stronger than its weakest link and the steering system follows the same rule, its weakest point is usually lying between the junction of the steering arm with the drag link and the worm and sector. A mistake frequently made is that of putting in a steering gear that is too light for a heavy car, and when subject to heavy shocks is liable to bend the arm or shaft; then the degree of right and left throw is changed, possibly so much that the car will not turn a corner without reversing. When the weight and speed of a high-powered car are considered, the hard driving over rough roads, the steering system is subjected to very severe shocks, and the remarkably few accidents that are caused by the troubles which can actually be traced directly to the steering system is a

most convincing tribute to both the designer and the metallurgist.

#### Where the Steering Gear Is Apt to Go Wrong.

One high-powered heavy car has a front axle that has stood the shock of striking a telegraph post while traveling at a speed of a mile a minute. The axle between spring seat and steering pivot took the shock and the end was bent about three inches through without sign of fracture. The cross steering rod, connecting the two wheels, was fastened to the steering pivots by ball and socket joints. The knuckles are curved so that the balls hang directly downward and, entering directly into the socket, are held by an internal cup nut with castelled head and split pin. This works very well when new, but use—it being impossible to keep the joints free from dust—will soon change the shape of the ball from circular to elliptical at its equator, thus necessitating continual adjustment. The wear, not being evenly distributed, and the continual adjustment necessary to keep the sockets tight enough to prevent the ball passing through, caused binding when the wheels were cut to extreme left or right. When traveling over muddy roads the mud seemed to choke the sockets and allow the wheels to turn about only 20 degrees either way from straight ahead, and thus making the use of reverse necessary to get around a short curve. These faults are of secondary importance when it must be said that the cross rod has dropped while on the road. One car suffered this while traveling on a mountain road, but the driver stopped the car before any damage was done. On another occasion the rod dropped and caught between the spokes of one of the wheels. The car was running very slow at the time and the wheel did not suffer beyond a little paint. On account of wearing considerations, the amount of adjustment allowed for must be limited and this is soon all taken up. A partial remedy is to be had in enclosing the joints in covers and packing them with grease. Considered from the manufacturer's standpoint, yoke-shaped connections would be cheaper to forge, machine, and would be absolutely free from the many troubles the ball and socket type is heir to. Very few people would care to purchase a car subject to steering gear troubles.

There is no perfect car, though some cars have reached a high standard of development. Their designers, studying the action of each individual piece of mechanism, and giving it all conceivable tests to eliminate faulty or poor designs, and thus working continually on the same type of car, have it developed as near to perfection as the engineering standards of to-day have reached. The use of chrome-nickel or vanadium steels in axle or crankshaft may indicate a desire to put the best material that money can buy into the car, but they will not help a defective fuel or steering system in the slightest. Improvement in design, to be effective, must be applied to what experience shows to be defective.

## ONE OF THE NEW USES FOR OLD AUTOMOBILES

MANY photographers in the East-end of London publicly advertise that clients can be photographed in a motor car if desired, says *The Car*. In conversation with an assistant in one of these studios, he explained the details to the writer. No extra charge is made for the temporary use of the car to-day, though, when the idea was first adopted, this was done; but the competition between the photographers on Sundays, when most of the business is done, is so keen that the charge has been done away with. The cars are hired for the occasion, and all the extras, even down to the goggles and ladies' veils, are supplied. The young man is instructed how to take his seat, and the young lady is asked to compose her features, but the advice is generally useless, as, in the words of my informant, "ninety-nine out of a hundred of them look as if they would be more at home on top

of a 'bus." On Sundays, parties follow each other, and those who are waiting their turn stand in the yard and watch their predecessors being "took." On weekdays those who wish for the use of the car must notify the photographer beforehand. It would be a dead loss for him to get the car for one party, so he takes the names of those who desire this style, and when he has got a half dozen parties who are willing and able to attend on the same day he arranges for everything. The cars used in this way are ones that have had their day and have been superseded by more up-to-date vehicles. The aliens, who are so numerous in the East-end, are particularly fond of being taken in this manner, in order to send the cards home to impress their relatives with the success they have achieved in England, as the subjects manifest a fitting sense of the importance of their position.

## DETAILS OF THE FOUR NATIONAL MODELS

WITH a view to meeting as widely varying demands as possible, the National cars are being shown this year in four distinct models of touring cars, in addition to which there are the National roadsters and limousines, so that there are practically eleven models in all. These are divided into two groups, the four- and the six-cylinder types, though there is a striking amount of similarity, not alone between these, but all of the cars, so that any of them will be recognized at once as the product of the same factory. Of the four models, the little six is new, as is also the big four, Models N and T, respectively. The policy of the National designers of adhering to separately cast cylinders has been departed from to the extent of employing cylinders cast in pairs on the small six-cylinder model, though both the large six- and the large four-cylinder machines still have separately cast units. The motors are all turned out in the home factory, and are characterized throughout by those features that have become distinguishing marks with the builders of the National.

Chief among these is the employment of the D. W. F. ball-bearings for supporting both the crankshaft and the camshafts, there being seven of these annular ball-bearings on the crankshaft of the large six-cylinder car, and four on that of the little six, owing to its twin cylinders. Double ignition, employing two sets of plugs, one placed over the inlet valves and the other over the exhaust, characterizes all four models. With the exception of Model K, which is one of the representatives of the National line that is substantially the same as its 1907 predecessor, a Bosch high-tension magneto is employed as the source of ignition current. On the Model K, a Remy high-tension magneto forms the equipment, the supplementary ignition in each case consisting of a storage battery with a single coil and high-tension distributor.

One of the distinctive features of the big six National is the employment of brass closing plates for the openings left in the sides of the jackets of the single-cylinder castings, which are of the outboard valve-port type. The use of this form of construction permits the cylinders to be placed very close together, and makes a very much shorter motor than is possible with the regulation type of closed jacket, in addition to which the large openings permit of the effective removal of all the core sand. The little six is the only National on which twin cylinders have been employed, but the manner in which the design is carried out would make it appear that the National designers are fully as conversant with this type as that to which they have

devoted all their attention for several years past. All the castings are made with flat tops, and the water piping is greatly simplified, besides being made less conspicuous by carrying it along the sides of the cylinders. The same yokes are employed on each side to retain the inlet and exhaust manifolds and the respective circulation piping on the same side. Gaskets have been eliminated on all these joints, ground taper joints having been substituted, thus facilitating repairs and reassembly.

The valves are all made of nickel steel heads on machine steel stems, the diameter being 2 inches in the big six, and 1 7-8 inches in the little six, all being made interchangeable in the various models. Hardened and ground lifters, working in bronze housings, equipped with felt boxes to prevent oil and dirt working into the crankcase, are employed.

The pistons are made with heads slightly domed, and carry four angularly split compression rings, all of which are placed above the wrist-pin. The connecting rods are made with marine type big-end bearings, and are split at their upper ends. Steel and bronze spiral pinions are employed for the timing gears. A Crandall mechanical oiler takes care of the essential of lubrication, the oil being distributed directly to the cylinders, the crankcase, and to the change-speed gear and rear axle unit, the oil for these different parts all passing through sight feeds on the dash. The practice of distributing oil directly to the transmission system of the car eliminates quite a number of grease cups. The water-circulating pump is situated forward, on the left hand of the motor, and is driven by a separate shaft, the Bosch magneto being similarly situated and driven on the right-hand side.

In Model T, the big six-cylinder car, the motor has 5 by 5-inch cylinders, while its wheelbase is 127 inches and its rolling equipment consists of 36 by 5-inch tires. In Model R, or the little six, the cylinders measure 4 1-2 by 4 3-4 inches bore and stroke, the wheelbase is 116 inches, and the tires are 34 by 4 1-2 inches. The large four-cylinder car, Model N, also has 5 by 5-inch cylinders, its other dimensions being the same as those of Model K, which has a 4 7-8 by 5-inch motor, 122-inch wheelbase, and is shod with 34 by 4 1-2-inch tires. The Schebler carbureter is employed as a standard part of the equipment for this essential on all of the National motors.

No attempts at the introduction of untried innovations are to be found on any part of the chassis of the various models, and this is particularly true of the transmission systems, which are substantially the same as those which have always distinguished the National cars. The

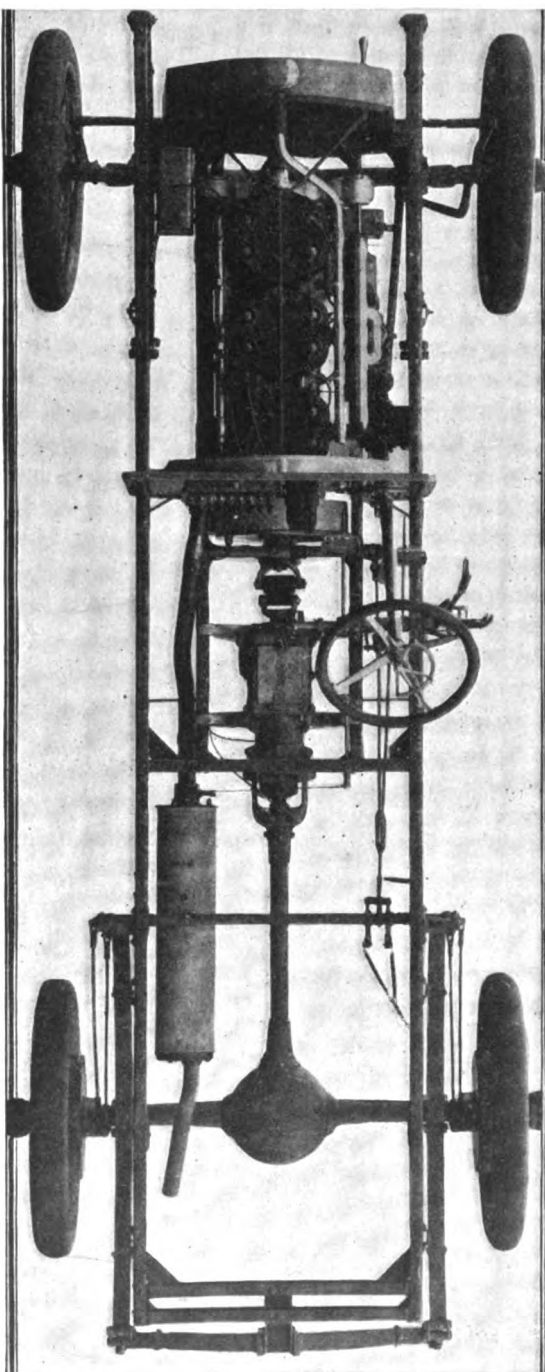

Chassis of the National Model R "Little Six."

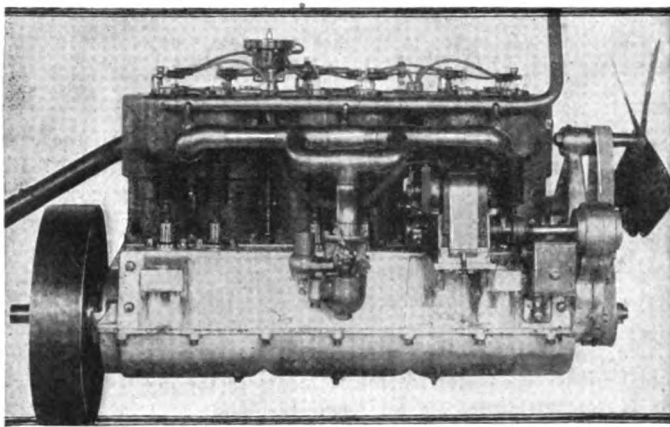

Magneto Side of the National "Little Six" Motor.

time-tried leather-faced cone clutch is to be found on all of them, eight flat springs being interposed between the leather and cone, to ease the engagement and assist in releasing the clutch. These springs rest in recesses cut in the under face of the leather band. Uniformity of design is also to be found on all four models where the change-speed gear is concerned, a selective type giving three forward speeds being employed in each instance. This gear box is of a distinctive type of design that has long been identified with National practice, in that the main and counter shafts are both carried in the same vertical plane, the main shaft being superimposed. It is supported on three liberal-sized Hess-Bright annular ball-bearings, while the countershaft requires but two. Connecting the gear-set with the rear axle driving unit is an enclosed propeller shaft, the tubular housing having a yoke end forward hinged to one of the transverse members of the frame, while at its rear end it is brazed directly into the spherical steel differential housing. Between this supporting tube and the driving shaft, two annular ball-bearings are interposed, one at each end.

In the braking equipment the usual practice of concentrating the brakes in drums placed on the driving wheels has been followed. Both the running, or service; and the emergency brakes, are of the expanding type, the former engaging against the inner face of a drum 11 inches in diameter, while the latter engages

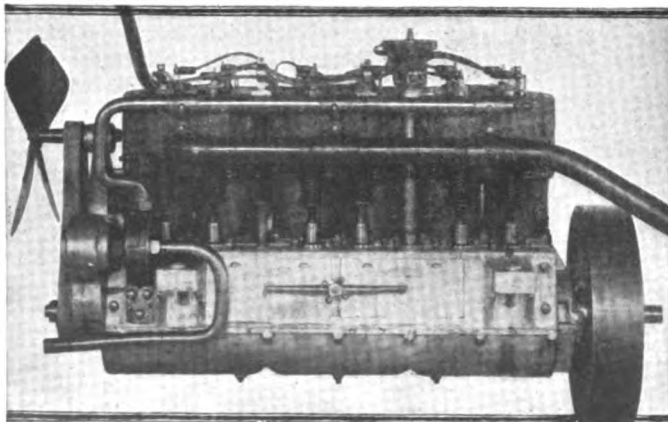

Showing the Simple Water Piping Arrangement.

a 15-inch drum. Instead of the usual friction materials employed for this purpose, a metal-to-metal contact is employed. Ball-bearings have been specified wherever good practice has indicated that they could be used to advantage, so that in addition to those used on the crankshaft and camshaft, the gear-box, propeller shaft, differential and the like, they have also been introduced into the support of the steering knuckles.

Use is made in all the models of the platform type of spring suspension in the rear, the side members employed in connection with these transverse springs being exceptionally long, ranging from 56 inches in the big six car to 50 inches in the little six, as well as both the four-cylinder models. The big six carries a 39-inch transverse member for the platform suspension, while in others this spring measures 37 inches. The forward suspension consists of the conventional semi-elliptic springs, measuring 40 and 44 inches in length on the models already classified. The form of subframe construction for the support of the power plant and change-speed gear, as hitherto used on the National cars, has been adhered to without any change. On all, except the Model K, an option is given on either the new type of straight line bonnet adopted this year, or the familiar round bonnet and radiator that have always been

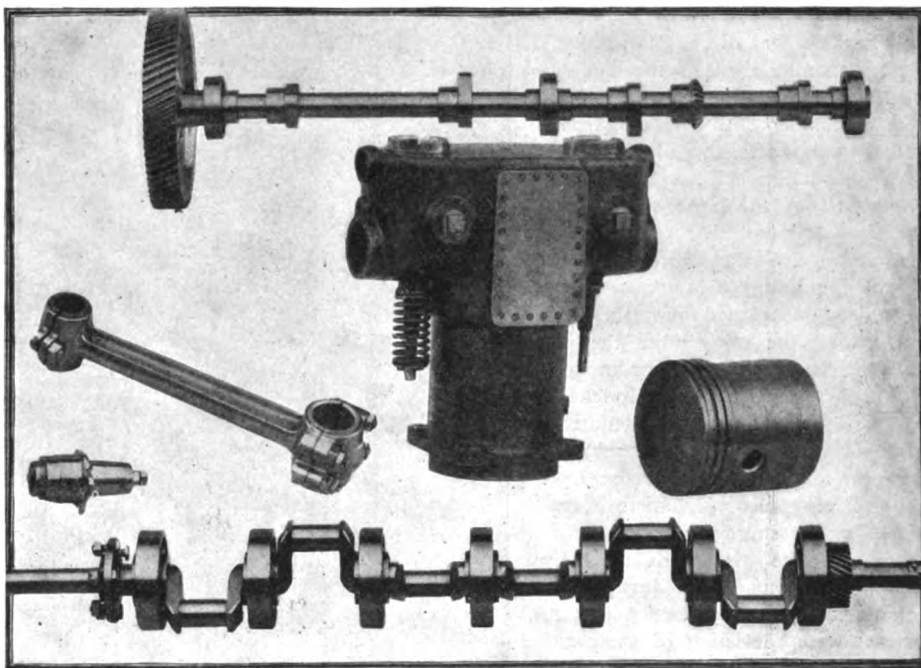

Some Essential Components of the National Motors, Including the Ball Bearing Crankshaft.

National features, and that are familiar on road and track.

It will be evident from a review of the foregoing specifications of the National line for the present season that time-tried and approved engineering standards have been closely adhered to throughout. The cars represent the result of an evolution extending over several years, rather than a complete construction designed to meet the present demand and to be abandoned in favor of something different a year or so later. The original structure stands out prominently beneath the numerous detailed improvements that have been added from year to year, the process being one of constant refinement rather than change. This is equally true where the new models are concerned, as it is with their predecessors, as the same features of construction that characterize the latter have been applied in designing the new cars, which reveal the same painstaking care in the execution of those numerous details of construction that go to make a car reliable in everyday service, or the reverse, according to the manner in which they are taken care of by the builder. It is the little things that count on an automobile, and that they have been amply provided on the National models is apparent.

## LETTERS INTERESTING AND INSTRUCTIVE

### WIRING CELLS FOR A SINGLE-CYLINDER MOTOR.

Editor THE AUTOMOBILE:

[1,319.]—I am sending you herewith a rough sketch of a wiring diagram for a battery on an auto, and would like to hear from you whether it is correct or not. Please publish a correct diagram, showing how to wire eight cells for a single-cylinder motor, as I think it would be of much interest to some of your new readers, of which I am one.

A. D. CARPENTER.

Sauk Center, Minn.

The sketch you send is correct for wiring eight cells in series-multiple connection, that is, two groups of four each in series (zinc to carbon), while the groups themselves are connected up in multiple (carbon to carbon and zinc to zinc), thus giving the voltage of four dry cells and the amperage of two. The accompanying diagram shows how to wire eight cells for use with a single-cylinder motor. Connect the two groups of four in series as already explained, using a common ground connection for both, as shown at the left-hand end of the sketch. The horizontal lines in the form of an inverted pyramid constitute the accepted symbol for a ground connection. Provide a three-point switch and connect the terminal of one group of the batteries to point No.

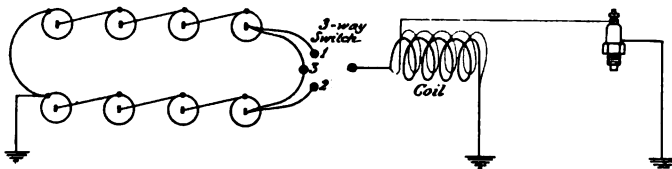

Diagram for Wiring Eight Cells for a Single-cylinder Motor.

I, as indicated; then connect the second set to point No. 2, as shown. By moving the switch lever from 1 to 2 the different sets of cells may be used alternately. Connect the carbon terminals of both sets of cells to point No. 3 on the switch. This will give a series-multiple connection enabling both sets of cells to be used together and will be found handy when they are no longer fresh. Connect the other end of the switch lever, indicated by the single point at the right, to the primary, or low-tension, side of the induction coil. Both the primary and secondary windings of the coil must be grounded, as shown, this usually being made in the form of a single connection by coil makers. A high-tension cable is led from the secondary of the coil to the plug. The ground connection indicated on the latter is taken care of by its insertion in the cylinder.

### WOULD LIKE TO HEAR FROM MAXWELL OWNERS.

Editor THE AUTOMOBILE:

[1,320.]—I would like an answer to the following: I have a Maxwell two-cylinder touring car which I ran 5,600 miles last year and one thing about its running has annoyed me and it remains an unsolved problem. The engine on starting will miss a few strokes, then black smoke issues from the muffler, and finally on giving it more spark and throttle, everything is all right and there is ample power for hills and sand and speed up to 30 miles an hour. How to make this engine pick up without the bad mixture having to be worked off is my problem. If it be liquid gasoline sucked up into the cylinders shutting down the needle valve, opening the air ought to cure it, but I am compelled to set the air and needle valve where it will give the power required on the road. If I might hear from some Maxwell expert or owner, I will be happy. Should any owner care to correspond with me, I will exchange experience.

Oak Park.

CHARLES J. RADWAY.

Maxwell owners who have had similar experiences, and who think they can help Mr. Radway out of his difficulties, may write to this department and their letters will be published here, or, if Mr. Radway will send his complete address, it will be given to those wishing to correspond with him direct.

### GREASE-SAWDUST "DOPE" FOR SILENCING GEARS.

Editor THE AUTOMOBILE:

[1,321.]—Somewhere I have read of a combination of grease and sawdust for use in front timing gears to prevent the roaring of the same, especially when the motor is running fast. If you can enlighten me as to the proportions of each, I will much appreciate it, as this is an annoyance which it appears difficult to correct on my car.

HARRY S. HALL.

A mixture of grease and sawdust has been adopted in street railway practice to silence the reduction gears between the motors and driving pinions, and works very effectively. In isolated instances the same expedient has been resorted to for the purpose of silencing the change-speed gears on old cars. What is known as jeweler's sawdust would be the best material for the purpose, owing to its fineness and uniform consistency. The proportions will naturally depend upon the character of the grease employed, but sufficient should be used to make a mixture of a comparatively stiff consistency that will not work out of the case. This combination cannot be employed in a location where it is apt to find its way into ball bearings, as the material will get into the races and the balls will act as a mill, quickly becoming very hot.

### IGNITION AND VALVE TIMING ARE WRONG.

Editor THE AUTOMOBILE:

[1,322.]—Will you kindly give us some suggestions regarding our Reo engine? We have a 1905-1906 Reo car, and have changed the two carbureters for a single Breeze carbureter, but we cannot get both of the cylinders to run when the motor is slowed down. We have carefully examined the valves and have timed the engine exactly, according to the best of our knowledge, so that both cylinders take gas at the same time and spark at the same time. The compression in both cylinders is the same.

Choptank, Md.

W. M. WRIGHT & COMPANY.

If you have so timed the motor that "both cylinders take gas and spark at the same time," it is marvelous that you have succeeded in ever getting them to run properly. In the two-cylinder, horizontal type of engine, such as the Reo car is equipped with, it is customary to place the crank throws 180 degrees apart. Thus, the pistons both approach the center and recede from it together. Hence, when one cylinder is firing, the other one is drawing in a fresh charge, and when the cylinder which has just fired, is exhausting, the other one should be compressing. Then the cycle of operations is repeated. If you will adjust the valve and inlet timing of your motor so that it may work as outlined above, you should have no further trouble with it.

### EXPLAINING THE DIFFERENT METER READINGS.

Editor THE AUTOMOBILE:

[1,323.]—I noted "Four Cylinder Sal's" queries in regard to coil testing experiments. He brings up a number of interesting points. From reading his letter I think that I am correct in assuming that the readings which were higher for the French instrument were made in series with a vibrator coil, also that in both cases where the instruments were compared with a standard this was done with a constant, continuous current. The fact is that two instruments which agree perfectly with each other when compared by means of a continuous current may, especially if of different construction, show widely varying results when connected to an interrupted circuit, such as that which embraces a vibrator coil. The explanation of this fact is briefly as follows:

The current is at zero amperes when the circuit is first established at the vibrator, rises till the maximum amount is reached, which is at the instant of the breaking of the same by the vibrator, when it falls rapidly to zero. This process is repeated while the coil is in circuit at about seventy or more times per minute. The result is that, owing to the inertia of the indicator needle and other causes, the needle has not time to either reach the maximum value of the current or to return to zero. It therefore takes up a position about midway between these two points. For various reasons some instruments respond much more readily to the rise



of current than to the drop. These will therefore give a higher reading than instruments which are not so responsive.

The explanation of the apparent discrepancy of the two standards may, of course, be explained by assuming that the amperemeters may have undergone a change during the time elapsing between the two comparisons or that one or both of the assumed standards were not such. On the other hand, it may have been the fact that in the second case the comparison was made by substitution, and that the pocket instruments had a slightly greater resistance than the standard instruments, thus altering the resistance of the circuit and the amperage. Theoretically the resistance of an amperemeter should be zero, and in standard instruments it closely approaches this value. While in small-sized pocket instruments it is probably much greater than in standards, yet under the conditions of actual use this resistance is so small when compared to the total resistance of the circuit as not to materially affect results.

HAROLD H. BROWN.

**HELPING HAND FOR FORD RUNABOUT OWNERS.**

Editor THE AUTOMOBILE:

[1,324.]—In letter No. 1,217, March 12 issue; also letter No. 1,277, of March 26 issue, in regard to trouble with Ford runabout, would say that I think I can help them out of their trouble. The trouble I think is with the pipe that runs from the gasoline tank to the carbureter. The brass pipe that runs from gasoline tank to carbureter runs close to and parallel with exhaust pipe. When going

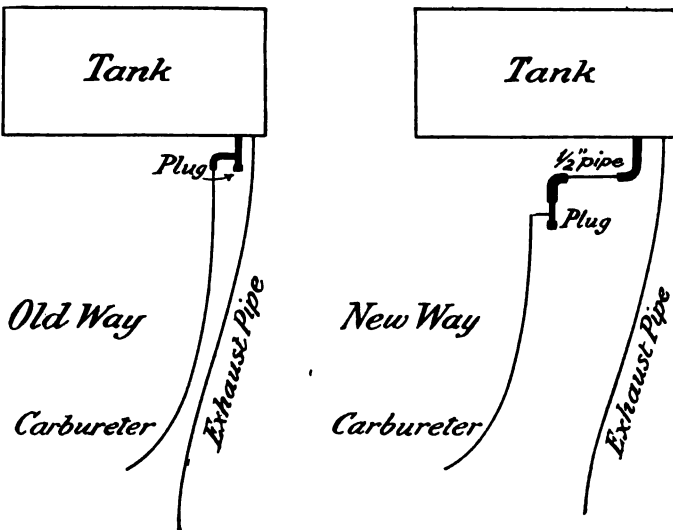

Suggested Change in Gasoline Pipe Supply Arrangement.

up a hill, or, perhaps, after running 8 or 10 miles without stopping, the exhaust pipe gets almost red hot, and that in turn makes the brass gasoline pipe hot and this makes gas of the gasoline before it gets to the carbureter, and that makes a weak mixture and loss of power. To remedy this, disconnect brass tube at gasoline tank, take out plug at the bottom of the tank, get one-half inch street ell, put in bottom of tank in place of plug that was taken out, then get a one-half inch piece of pipe about 4 inches long, threaded at each end, put one end in street ell, then get one-half inch elbow, put on other end of pipe. Put the plug that was taken out of tank in the elbow, connect gasoline pipe and then you have it. Care should be taken not to have one-half inch pipe too long, so as to be sure that the brass pipe does not rub against driving shaft, as it might wear a hole in it. Below is a rough sketch of what I mean. This is a very easy job, and anyone can fit it in half an hour, as the bottom of tank is threaded to take one-half inch street ell where plug is taken out.

Battle Creek, Mich. CHARLES GILBERT.

**MR. FRANKLIN BOTH AGREES AND DISAGREES.**

Editor THE AUTOMOBILE:

[1,325.]—Your reply to Mr. Fay's question: "Why is it that there are not more high grade cars driven by air-cooled engines?" is certainly very fair; we think practically correct, so far as it goes.

However, we are inclined to take exception to your statement that "It appears to be more difficult to sell air-cooled cars." Is it more difficult? In most cities where the Franklin is sold its sales are larger than the sales of any other one make of automobiles, and in some places the sales of the Franklin outnumber the combined sales of all other makes of automobiles. For example, in the State of Washington we have twice as many cars as our

nearest competitor, which is a low-priced water-cooled runabout. In 1907, 119 Franklins were sold in the city of San Francisco. Of the American manufacturers there are only two or three who sell more automobiles than this company, and these are the makers of the very low-priced machines. In value of sales the Franklin is probably about next to the top.

We think the point is, that a water-cooled automobile is easier to make than an air-cooled automobile; that is, there is less knowledge among manufacturers of the science of air-cooling. Most anyone can make the water-cooled motor, as only ordinary knowledge is required, it being easier to cool. In the air-cooled motor, it is a case of knowing what to do and doing it scientifically.

Otherwise, we agree with all you say.

H. H. FRANKLIN MFG. CO.,

H. H. FRANKLIN, President.

Syracuse, N. Y.

**CITES AN ADDITION TO MR. GODLEY'S LIST.**

Editor THE AUTOMOBILE:

[1,326.]—As a reader of your journal, I was interested in the article of the 9th, comparing American and foreign light cars. Your statement that the only American cars of that class were the Thomas 16-20 and the Franklin 16-20, omits the \$1,100 Cameron 16-20, 4-cylinder, air-cooled touring car—a reliable little vehicle. It seems to me that there is a great field in this country open to this class of car, on account of their initial low expense and their low rate of operating and tire charges. On the other hand, they can give to the ordinary man, who has not more than \$1,500 to put into a car, all the service and roadability he usually needs. For such a car it would seem that the ideal engine is a three-cylinder, air-cooled, two-cycle engine, with friction transmission and double side chain drive (chains enclosed), reinforced wooden frame, magneto ignition, the power to be from 15 to 20 or 22 horse. I venture to prophesy that five years hence will see many cars built along the above outline in actual use in this country.

Brooklyn, N. Y.

"TWO CYCLE."

**ATTRIBUTES DIFFERENCE TO ERROR ON SCALE.**

Editor THE AUTOMOBILE:

[1,327.]—In reply to letter No. 1,292, in the April 9 issue, I would suggest that the readings taken on the coils and the readings compared with the standards were on different parts of the scales. Now many of the low and medium-priced meters used in laboratory work are correct in one part of the scale (usually near the center) and have a considerable error near the ends of the scale. This might explain why the errors were so different with different current readings.

H. A. FISKE.

Kingston, R. I.

**TWO-CYCLE, TWO-CYLINDER FRICTION DRIVE.**

Editor THE AUTOMOBILE:

[1,328.]—In answer to letter No. 1,297, in the issue of "The Automobile" of April 9, there is a two-cycle, two-cylinder, friction-driven runabout made here in Buffalo and called the Chief. The concern that manufactures it has an office in the Ellcott Square, Buffalo. I am under the impression that it was first shown here at the automobile show this year. It has either 28 or 30-inch wheels, and is somewhat similar in appearance to the Model N Ford.

GEORGE N. LIPPITT.

Buffalo, N. Y.

**OUTSIDE INFLUENCE CAUSE OF DIFFERENCE?**

Editor THE AUTOMOBILE:

[1,329.]—Referring to your query No. 1,282, under "Letters Interesting and Instructive," it has occurred to the writer that possibly the meters referred to are of the permanent magnet type, in which case, in using or making tests it is quite important that they do not come in close proximity to other similar meters, magnets, or iron of any nature. This will affect the reading, and it is possible in making the tests referred to that this point was not considered.

E. C. WILCOX.

Meriden, Conn.

**DURYEA BUGGYAUT MEETS THE REQUIREMENTS.**

Editor THE AUTOMOBILE:

[1,330.]—Mr. Strawn's inquiry for an auto using friction drive and two-cylinder motor is met by the Duryea buggyaut. It is also air-cooled, using two cylinders 4 3/4 by 4 3/4 inches. The peculiarity of this vehicle is the arrangement of the drive. It consists of grooved rollers bearing in large grooved rings and drives much as does the locomotive wheel on the rail. These rollers are of two or more sizes, and can be shifted by steps so as to give different speeds, but not a variable speed.

CHAS. E. DURYEA.

Reading, Pa.



At last the problem of how to be both *chic* and warm when autoing has been solved. The day of the fur coat is almost past, so far as this season is concerned, and already there is a lively sale of cloth and pongee wraps with linings that make them comfortable for early spring wear, and yet these same coats are not too heavy for certain summer use. A prominent importer is showing some unusual styles in homespuns and Scotch tweeds whose lines are plays on the voluminous evening wraps we have seen during the past winter. The accompanying illustration of the papillon coat represents one of the picturesque models fashioned after the popular butterfly wrap that every woman who owned one found it the most comfortable outer garment she ever possessed.

The cut of this coat is quite out of the ordinary and extremely smart, yoke and sleeves merging into one, yet with noticeable absence of the much abused Japanese sleeve. The collar is wide and provided with an extra piece of cloth cut triangular shape which may be closed snugly under the chin, bringing the collar over the ears. Fancy metal buttons close the fronts of the wrap, which spread to generous proportions as they near the hem, while a bias seam at the back saves it from uncomfortable bulkiness. The material employed in this remarkable garment is tweed nearly half an inch thick, but as light in weight as eiderdown. Golden brown with indistinct markings of Irish green make this particular papillon coat one of the most attractive that has been placed upon the market this season.

One of the most interesting features of the spring fashion exhibits are the oddities in automobile coats. At a recent opening there was a prevalence of light colors made even more conspicuous by touches of brilliant hues such as flame color, scarlet, jockey green and kindred shades. On an imported pongee coat the accessory color was canard blue—that intense tone found on the tips of the wings of fancy ducklings. Another extraordinary combination was olive green pongee and Japanese coral. Beside the pipings and lining, which were of this color, the sleeves and fronts were decorated with large imitation coral buttons, which, together with long silk loops, closed the gar-

ment. With these gay color schemes running rife in extreme fashions, much variety and modishness may be achieved by judicious use.

Many models both artistic and serviceable are shown in various weights of pongee and rubberized silk. The choice in both materials ranges from the severe dust coat to the full flowing model with cape-like sleeves and ample fullness from shoulders to bottom. The natural tan or mode tones of pongee are in high favor, and make excellent foundations for the garish Oriental embroideries so much the vogue just now. With the prevailing craze for Danish blue, the Chinese blues which border strongly

on this shade are being pressed into service to great extent. And very pretty are these wonderfully wrought embroideries done in soft blues with now and then touches of yellow or green. These elaborately trimmed coats have an additional merit inasmuch as they accommodate themselves to almost any style gown and are in good taste for all occasions.

Quantities of handsome braiding are found on many of the elegant wraps for autoing. Showy ornaments and brandenbourgs in the color of the coat they decorate are also much used in connection with needlework. Another modish trimming is made of heavy cordings covered with pongee and formed into all sorts of fantastic ornaments and applied in conspicuous parts of the garment. Midway between the two extremes of severely tailored coats and those of fancy silk is the province of picturesque models less practical than the former and more expedient than the latter. Unless the elaborate automobile coat be treated with skill both in the cutting and ornamenting it becomes an unsightly thing to be shunned by women of discriminating taste. Thus it is advisable to consult only the best dealers when ordering automobile toggery that will meet the demands of fashion and retain, indefinitely, its smart effect.

The high Directoire collar is a feature of some of the recent importations, and whether of the turned down order or merely straight and high, is exceedingly becoming to the woman of long, slender throat. A long touring coat of biscuit-colored pongee, semi-fitting and falling gracefully from the shoulder, ripples slightly toward the hem and has bias folds of tobacco brown silk finishing the brown and cross-banded collar, cuffs and pockets. The effect is extremely modish, yet quite simple in treatment. On a similar coat of gray pongee the decoration consists of green leather tabs running down the front and fastening on opposite sides, also extending over the shoulders in Gibson effect. The high, straight collar is of the same material and closes tightly about the throat. Another stunning model, in elephant gray, is trimmed with tiny insets of shrimp-pink leather introduced in the collar and cuffs and in the centers of the braid, ornaments fastening the fronts.

Some exceedingly good auto coats in rubberized silk in gray, brown, tan, blue and green are being worn. Like all garments for this use, they are long and loose, and many of the smartest models, instead of having double-breasted fronts, fasten to the left side, thus allowing double thickness over the chest and no possibility of cold penetrating through the opening. This side fastening in one form or another is gaining favor with coat designers both here and in Europe. Many of the recently unboxed models show this mode of closing. The reseda green silk rubber coat pictured is an example of the possibilities of this side fastening, yet it has the appearance of closing directly in the front, and in all its details is a particularly charming model. Special attention is called to the white satin wind cuff, which feature adds admirably to the comfort of the wearer.

A certain well-known dealer in high-class automobile apparel is showing a capital wrap for easy access. This fetching cloak is of the Inverness cape type, comfortably long and warm. Like the first tweed coat described, this great cape is also fashioned of that delightfully light weight material that possesses nearly the same amount of warmth as fur. The rich crimson mixture



Biscuit Colored Pongee Coat with Plaid Trimmings.

is brightened by stitched tab effects of plain red broadcloth. So cleverly cut is this cape that its skirt provides ample fullness to doubly cover the lower part of the body with the overlapping fronts. Past experiments with double cape effects have invariably proven futile, despite all the improvised strapings to prevent the wind from pelting the face of the wearer with the corners.

When the auto coat is but lightly lined, or perhaps there is no lining at all, an extra waistcoat or sweater makes it more practicable for cool spring days, and all through the summer months such an adjunct would be a serviceable possession for long trips in the automobile. Brown and white and black and white checks in English worsted makes a stylish waistcoat that may be worn with almost any color wrap. Or, if these combinations are not fancied, here again is a splendid opportunity for an enlivening touch of color. In the matter of such details, one is at liberty to choose whatever is considered the most becoming, provided, of course, that the contrast with other articles of apparel is not inharmonious. Some women motorists prefer conspicuous waistcoats that show wide contrast when the outer wrap is opened, and if the coat be of somber hue this little vagarie is rather pleasing.

Certain English sweater models of fine wool, buttoning double breasted from shoulders to hem, are finished with straight standing collars of supple leather. The same material is found on the cuffs and the covering of the buttons, all of which trim the sweater effectively. Other styles in English sweaters have leather belts and pocket flaps, giving them a more elaborate appearance. A loose coat of heavy, rough material has, instead of a sweater to supplement its warmth, a stock and shield of knitted angora, and with it is shown a muff of the same soft wool, nearly three-quarters of a yard long and of proportionate width, with but little perceptible weight. These comfortable accessories are made

by the French nuns in their places of exile. The sets are white or smoke-gray, lined with self or contrasting color wool, also crocheted or knitted.

Nothing new in automobile veils has appeared, but all the old favorite designs are made up into voluminous hood-like affairs that cover the hat and tie at the side or back, the latter being the latest fad with the smart autoist. If there is any choice in the matter of designs, it falls to polka-dot effects. There is no fixed law as regards color, so long as the pattern offers plenty of contrast. The goggle that is pronounced most satisfactory by many enthusiastic women automobilists has but one lens or window. This gives the wearer unobstructed vision in every direction, while the double windows are claimed to tire the eyes. This new goggle is mounted on a dustproof wire screen which affords ample ventilation and which is made further comfortable by a chenille covering over the wire rim.

### SOME SPRING NOVELTIES SHOWN IN LONDON.

A new English coat designed for women automobilists' spring wear, and shown at Drykitt's in London, is built of grayish green Lovatt tweed, full length and double breasted, and is fitted with two separate detachable linings. The one is of squirrel lock, with which there is a soft nutria collar to fall over the tweed, and the other is of the finest Cape lamb leather, of extremely light weight. Both these linings are fastened in with patent studs. As the tweed is in all respects perfectly finished, it is possible to wear it without either of its linings, and thus three combinations are to be found in one wrap.

In London novelties, several light overcoats for women have made their appearance. One of these is in a soft shade of green, striped with a darker toning. The garment is nearly full length.

The other coat is in the same fine cloth in brown shading, and is made double-breasted.



A New Papillon Ulster.  
Courtesy Scandinavian Fur & Leather Co.



Silk Rubber Garment for Dress or Utility.

# AUTO TALES TOLD OF THE UNSOPHISTICATED

By CHARLES B. HAYWARD.

ONCE upon a time there was a man who set forth to become the possessor of an automobile, and, like unto most others of his ilk, he wished to see many, many cars before taking the fatal step—remember, this was in 1904—and, in the seeing, to accumulate one of those vast funds of knowledge with its attendant vocabulary that makes of a man an autoist. He had already looked over quite a number of what the salesmen had in every instance assured him, with much fervor, were the very best cars in the market—each one, in fact, was *the* representative American car. As to the others, the less said the better, though, be it said in passing, there was hardly a salesman in the lot who had not sufficient love for his competitors to put in a good word or two for the other fellow, merely to give a faint idea of how very, very rotten the other fellow's car actually was. Of course, he could say a great deal more and often did, but it is hardly necessary to dwell further on this phase of the matter.

As already mentioned, the seeker after information, and a car, had seen quite a few when he was introduced to one that was the virgin four-cylinder vertical product of a factory that had, up to that time, devoted itself exclusively to the production of smaller cars and had made quite an enviable reputation thereby. Consequently the name of the car was not strange, though this was something that could not be said of its appearance. Other cars had salient points, but it required their backers to bring them to the notice of the intending purchaser; on this one they stood out all over, no one could possibly miss them. After taxing the powers of the salesman not a little for one of his caliber, for some salesmen were not any better equipped with technical knowledge than they are now, one of the members of the agency firm who *did* know the car joined in the conversation, or rather relieved the salesman, much to the latter's satisfaction. "What on earth do you put such extraordinarily long hubs on your car for?" resumed the interrogation point. "Oh, those," said his new informant, "best hubs on the market. Clever piece of designing, that. Those hubs are water-cooled. You can drive your car up any hill you can find and your wheel bearings will never get hot. Great thing to have on your car."

But the seeker was not sufficiently convinced and passed on, and in the course of his rounds examined other cars. Carburetion, ignition drives and the hundred and one other preliminaries that the man who is learning the game wants to know all about having been thoroughly gone into, on the next one he came across, the seeker thought it was time for him to ask a few. "Your car hasn't got water-cooled hubs, has it?" he naively inquired. "Water-cooled what?" said the salesman. "Why, water-cooled hubs to keep the bearings from running hot, especially when you're climbing hills."

## The Show a Most Prolific Source.

Probably 90 per cent. of all the tales told of unsophisticated buyers have their origin at the annual shows, and, despite the vast spread of technical and *quasi* technical knowledge that the automobile has brought in its train, the crop appears to be unflagging, though, perhaps, not as generous as it has been in former years. Whether it be due to the fact that the salesmen of one year are the general sales managers and presidents of companies of the year following, certain it is that the crop of utterly unsophisticated technical talkers, whose mission it is to interest the prospective buyer, is never lacking. Cars may come and cars may go, but the salesman who has to refer you to the "technical man" or the "factory man" or the "mechanical man" of the firm, the

moment your inquiries get beyond the merest commonplace of automobile construction, is apparently always in the front row and the first to catch the eye of the visitor who means business.

Not that the salesmen are any worse than some of the prospective buyers who feel that they have primed themselves with miscellaneous mechanical information and are not at all backward in making the fact known, for it is quite frequently a case of Greek meeting Greek, and the result is almost invariably a tale that is worth the repeating. One of these that grew at the Chicago show was of this order. The prospective one had carefully looked over every part of the car with an extremely knowing air and finally stooped down to take a view from beneath. "My, but that's a large fly-wheel you have there," he remarked; "I don't like that feature at all. What's the use of carrying such a big wheel around with you all the time?" "Oh, that's all right," the salesman assured him blandly; "we'll give you any size fly-wheel you like."

## The Eternal Feminine Is Not Lacking.

Some women pick up technical talk almost as quickly as they do conversation of a nature commonly reputed to be an inherent shortcoming of the sex, and, like their brothers, they are not a bit averse to showing their knowledge on occasion. This is another show story. The salesman had realized his opportunity and had discoursed at great length on the advantages of separate cylinder castings, and his hearer drank it all in in order to be able to summon it to her assistance at some future psychological moment. "What did he mean by a 'five-bearing' shaft?" asked the wise one's companion, as they were about to walk away. "Oh you see, on this car," illustrating by reference with a daintily gloved hand to the polished chassis, "there is a crankshaft between each cylinder." "Oh—"

But the salesman feels himself on much firmer ground when he has one of the fair sex to deal with, as even the most innocent-looking of male visitors may turn out to be a sharp. True, upholstery and paint is no longer the chief topic of the automobiling girl's conversation at the show, although she can't get away from them altogether, but it is a rare bird indeed who can boast much knowledge of mechanical details, and the salesman can usually bank upon that. One of the representatives of this species that is almost *sui generis*, i. e., automobile salesmen, was taking much pleasure in describing the beauties and mechanical advantages of the product of his firm's factory, and had progressed very smoothly over a great deal of what might have been shaky ground had even a fairly well-informed male visitor been the interrogator, when the lady asked him, "Oh, what is that there? You haven't told us about that, and I don't remember ever having seen one of those on a car. Our car hasn't got any such thing as that on it, has it, Gladys?"

"Why, all cars have that on," said the professional smooth talker, "only you're not at all apt to see it when the body is on. That's the *contortionist* rod."

## But Races Also Produce Their Quota.

Probably the number of stories that have their origin at the automobile race track or along the scene of a big road race are not only far more numerous, but likewise more amusing than those which the show stands bring forth. Unfortunately, however, few of them appear to get into current circulation and so usually fail to come within hearing distance of the man with the retentive memory, or, what is better, the little note book, except when their perpetrator



happens to hold an official position, as was the case in the following instance. He was the referee of one of the 24-hour races, but it goes without saying that he had not been appointed to the position by reason of his great knowledge of things automobile. All the contesting cars had been carefully weighed in at the beginning of the race, and the same procedure was to be gone through at the finish in order to verify the weights. During an intermission, one of the competitors who was then in the lead stopped at the grandstand and jokingly asked the referee if he could take the carbureter off his car in order to save weight. "You can do what you like," replied the official in question, with all due seriousness, "but I'll disqualify you at the end of the race. The rule is the rule."

A number of years ago when there were so few gasoline cars in existence that excitement was derived almost entirely by racing electric cars at county fairs, a designer who was then prominent in that field, and is now even more so as a producer of gasoline cars, took two of his machines down to one of these festive agricultural celebrations held in the vicinity of Providence, R. I. The machines were naturally objects of the most engrossing curiosity to the tillers of the soil who had never seen anything but a two-wheel cart drawn by a hay motor on the race track, and they crowded as near to the vehicles as their sense of personal safety would permit. The machines were designed to make high speed, and consequently could not run very far without being recharged. An impromptu charging room had been rigged up under one of the horse sheds, the current being taken from the trolley circuit on the road outside. The process of charging was the thing that mystified the graybeards most.

"How much does that 'ere machine weigh, neighbor?" curiously inquired one of them of the assistant in charge of this very essential part of the business of racing an electric automobile. "Oh, about a ton, ton and a half, I guess," was the reply. "Crickets, much as that, eh? And how much does she weigh when you get her full?" "Full of what?" "Why, full of 'lectricity, of course. Ain't that what you be shootin' into her now?" Lack of space prohibits attempting to detail the various and sundry arguments by means of which that assistant tried to instill into the agriculturist some of the most elementary principles of electricity with a view to convincing him that it was not sufficiently tangible to have weight, but all in vain. "She must weigh more when she's full. Stands to reason, must be so," and his hearers, with one or two exceptions, were of the same opinion.

#### Factory Men Have Volumes Tucked Away.

Get an experienced factory man in a mellow and communicative mood and he will open the recesses of his memory. It is more than likely that therein is stored a vast accumulation of tales both amusing and instructive, for no man can go through seven or eight years' experience in building and selling cars, not to speak of repairing them, without having such things actually thrust upon him. Even though he be not blessed with an over-retentive memory, superinducing a reminiscient mood will be productive of a gem or two in the majority of instances, while if half a dozen designers and factory men could ever be prevailed upon to detail their experiences of this kind, there is little doubt that an amusing volume of short stories could be easily compiled.

On one occasion, the owner of a car, which he had bought earlier in the same season telephoned the factory that there was something wrong with the engine and to please send over and have it towed to the shop as it could not be run safely. An examination showed the crankshaft to be so badly bent that the repair was necessarily a lengthy job. The owner took occasion to come to the shop during the course of its carrying out, and was at pains to inform the superintendent that his chauffeur had put the car in that condition

by "running the engine on one cylinder." As a matter of fact, it was the chauffeur's fault, but a jutting rock in the road which could have been avoided was the chief contributing cause.

#### The Newspaper Man Always a Factor.

But your scribe can always be relied upon to furnish his quota when it comes to "breaks" of this character, and one of them that is quite a gem in its way was the outgrowth of the recent Importers' show in New York. It will be recalled that all the exhibitors on the main floor of the Garden were not builders of cars; there were one or two manufacturers of bodies included and as a means of attaining extra publicity one of them, whose name is a by-word on the other side where fine carriage work is concerned, used space in the daily newspapers to advertise *Carrosserie*, which was the only information vouchsafed, other than that of the firm name appended beneath. This tale brings to light the fact that there are more ways of obtaining advertising contracts than one, though this is a phase of the story that need not be dwelt upon at any great length. The advertisement had been running in this form without change for a week or two when a newspaper man from one of the many so-called "financial journals" requested an interview of the manufacturer. It was granted, and the seeker after business immediately handed up a lengthy type-written brief and requested the manufacturer's opinion of it, remarking, by the way, that it ought to be worth a contract, as if printed it would do him—the manufacturer—a great deal of good in the way of desirable publicity. The latter accordingly set himself to the task of perusing it. "Four-cylinder vertical, water-cooled motor—four-speed selective type transmission—shaft drive, highest standard of workmanship throughout, one of the best "French productions," and a great deal more to the same effect, he noted as he glanced over the numerous long folios of the write-up.

"What might this all be about?" he inquired of his visitor.

"Why, that's a good write-up of your new car that we're going to print, the matter of advertising being satisfactorily settled in the meantime, of course."

"Our new car? What new car are you talking about; we don't build any cars."

"Why, the new *Carrosserie* car, of course."

But the advertising members of the newspaper fraternity are not the only ones to get a bit off the track in this manner. As a matter of fact the scribes of the semi-society sheets are among the worst and most frequent offenders. It is hardly necessary to introduce their breaks; they speak for themselves, as witness the following gem, intended as a technical description of a new model, and taken from a Brooklyn weekly but a short time since:

"The motor possesses all of its valves, inlet and exhaust, on the same side. The cylinders are cast in pairs, and the crankshaft is separated by four bearings. This is a special patented arrangement of lubrication, assuring a continuous flow of oil to all bearings. . . .

"The eccentric rod controlled by the camshaft works, by the aid of a little rod, a pump in the lubricator in itself. It is found on the dashboard of the chassis. The pump driven from the motor sends the oil into the side feeds. The oil is directed from there to the four main bearings of the motor, the gear box and the back axles.

"The fifty-sixty horsepower chassis is fitted with a patented friction clutch, which is made of an ordinary leather cover, male cone encased in a cast rim, forming the female cone. The gear box is four speed forward and one reverse." This is not an extreme instance by any means, as it would be quite possible to cite some that are little short of unbelievable, so utter a lack of even the most rudimentary knowledge do they display.



SAVANNAH, GA., April 20.—“The Hermitage,” located four miles outside of Savannah, is an old plantation of antebellum days, settled in 1810 by the McAlpine family, of which Judge McAlpine, of Savannah, is to-day at the head. Autoists always visit it when in Savannah. On this plantation were originally owned 222 slaves and their families. The McAlpine family, naturally, did not believe in slavery, for each slave and his family were given a portion of ground, and on this ground he raised various products of the soil, taking them to the manor, or the “Hermitage,” as it is called, for sale. He received fair compensation for his work.

The spreading live oak trees on the plantation were planted in 1815, and form magnificent arches. The plantation is now deserted, and has not been occupied except by descendants of the slaves since the war. The old Hermitage is closed, and two of the basement windows, which are closed by tight boards, are supposed to be entrances to the dungeon, where unruly slaves were supposed to have been confined. This could not have been the case, as the windows enter the wine cellar of the former owner.

The building to the right of the entrance, as the plantation is entered, was the home of the former overseer. The post in front of the door was supposed to have been the whipping post, but this is also not the case, as no slaves were ever whipped at the Hermitage.

The grounds are a mile square, and are very beautiful. They were occupied during the war by a regiment of negro soldiers of Sherman’s army, who looted the place and ruined it. It has never been occupied since that time. It is understood that many overtures have been made to buy the Hermitage, but a price of \$400,000 is placed upon it.

Visitors in Savannah are invariably warned not to go too far from the grounds around the Hermitage, owing to the rattlesnakes. This is probably the most interesting point around Savannah, as the old slave quarters are shown, now gone to rack and ruin, and the descendants of the old slave families meet the visitors with the old coon songs of the days before the war. The former hospital to the left on entering is shown, and in the old days of the plantation a doctor was under contract to call weekly at the plantation and care for the slaves. Common report has it that this was undoubtedly the happiest of homes in the days of slavery, as slaves were taken splendid care of, and the family Bible is said to have recorded carefully, along with the births of the family, the births of the slave colony as well. This was exceptional “before the war.”

Hardly an hour of a pleasant day passes that does not present on the lawn and beneath the grand old live oaks of the Hermitage a vivid contrast between the old and the new, in the presence of automobiling parties. It does not require a surcharge of sentiment for those who have driven there in their modern cars to picture the family coach and four, rolling with ponderous dignity up to the porch; to see in the mind’s eye the pickaninnies swarm about the horses’ heads, or imagine the dignified master and stately matron of the mansion coming down the marble stairway from the porch to greet the arriving guests.







# Skirting Florida's East Coast

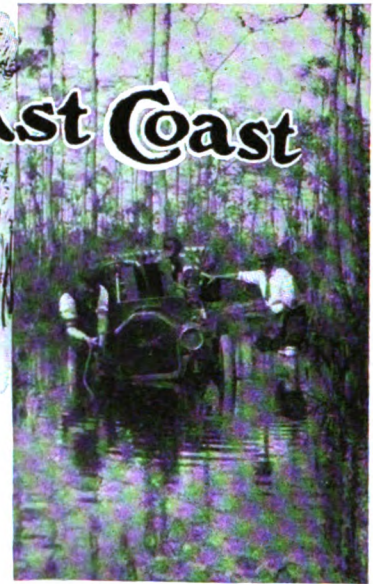

By  
**John C. Wetmore**

**T**HOUSANDS of automobile owning tourists make an annual Winter pilgrimage to the Florida east coast. Some settle down at one of the half dozen well-known resorts scattered along the Atlantic shore. Of these, practically only the so-jourmers at Ormond and Daytona, between which lies the world-famous beach speedway, bring their cars with them. At St. Augustine, Rockledge, Palm Beach, and Miami there is a bare scattering of cars outside of those maintained by enterprising auto-liverymen for hire.

Thousands are content each winter to make the journey down and up the coast by train, with never a thought of the touring and excursion pleasures their cars locked up in garages at home would bring them in this maligned, so-called auto-pathless Florida.

Thousands more in the North either store their cars for the winter, or use them in ploughing through snowdrifts, or bucking against face-freezing winds, longing for the coming of spring, or for some warm, not too inaccessible land that will give them touring between leaf-fall and flower-bud seasons.

To all of these, THE AUTOMOBILE correspondent, who has recently made the 372-mile run from Jacksonville to Miami, and in so doing enjoyed the most novel, picturesque, and delightful tour of his experience, recommends the Florida east coast. In the week between the Ormond and Savannah meets, he made the journey, the occasion being a race organized by "Senator" Morgan. It had but few starters, and fewer survivors, but those that stayed out missed a chance for a rattling good rough road battle, so far as competition counts, and a journey through Florida forests and along the Indian river that was a touring dream from the standpoint of novelty and picturesqueness. It goes without saying, and has been repeatedly proven, that an automobile can be pushed over any kind of road through any kind of country. The tourist can even ride with pleasure over rough highways, providing he be content to moderate his pace to suit conditions. Along the Florida east coast it is far from being an all-the-way battle with sand and corduroy paths. For one-third of the journey it is really good going, even when measured by Northern highway standards. For another third it is pleasant riding at a ten- or twelve-mile an hour gait. For the other third one has pretty hard fighting and slow ploughing over rough forest tracks and through heavy sand, not too hard, though, to be a cheap price to pay for the joys of the other two-thirds.

There are good shell, coquina, or gravel, roads in the neighborhood of all the resorts. St. Augustine has 12 miles of shell roads. There are 10 miles of fairly good country road into Ormond, and south, through Daytona and Smyrna, nearly to Oak Hill, 28 miles more of stone and shell highways. Ten miles of good traveling may be had in and out of both Titusville and Rockledge. Sixty-six miles of splendid coquina road stretches from Palm Beach to Miami. In a word, in the run down the coast one has at least 136 miles of good going. Not half bad for Florida, hey?

Four bona fide entrants started in the race from Jacksonville. There were two little 10-horsepower Cadillac runabouts. In one of them Morgan rode as far as Ormond, where its owner, Dr.

W. N. Stinson, took the wheel. The other had Claude Nolan for pilot. Dr. J. H. Pittman drove a 22-horsepower Buick as far as St. Augustine and then quit. The newspaper men went in a chartered 24-horsepower Peerless of the vintage of 1905, with its owner, C. F. Wheeler, at the helm. Harry Wilbur, of the Jacksonville *Times-Union*, and W. H. Harrison, of the New York *Tribune*, were your correspondent's fellow voyagers. Morgan joined the car at Rockledge, Wilbur having shifted to Dr. Stinson's Cadillac as a third passenger.

Much of the story of the trip will, of necessity, cluster around the newspaper car. And right here a tribute is due James Laughlin, 3d, for the splendid work he, Vice-President G. E. Sebring of the Florida East Coast Automobile Association, and their companions in the Cleveland Pathfinder did in laying out the route for the run. The route which was printed in Morgan's Ormond race program was unmistakable and accurate. Save for a 12-mile stretch between Rockledge and Fort Pierce (29:2 to 41:0) the odometer readings were absolutely accurate. The book even marked the dangerous stumps. At crossroads and doubtful places, signs were put up. Following the book and the signs—these for the most part in the little traveled forest and wilderness and not likely to be removed—it will be an easy task to make the run without a guide. A Pope-Hartford party did it thus without difficulty.

We had but crossed the ferry over the St. John river and gone less than five miles before we struck highways that should make the Duval county road authorities ashamed of themselves. Barring the run through a real wilderness between Fort Pierce and Palm Beach, they were the worst we encountered on our whole trip. The 35-mile run to St. Augustine was through a pine forest practically all the way. The road, though well marked, was little





more than a worn path, and at places there were stretches of sand. For all that, one can easily make the journey in three hours. We crossed small and sometimes shaky bridges and at times shallow fords. At places we passed saw mills and turpentine camps. We stopped at Bayard Station at a combination inn and general store for dinner. Its proprietor, whose name I have forgotten and I took no notes, John Anderson tells me is doing a lot of hustling to stir up road building reform in this county. He gave us some valuable hints as to new paths laid out since the pathfinders went through.

Just outside of St. Augustine we struck welcome shell roads carrying us into town. You see, we had been detained by a luckless leaking radiator and so decided to spend the night with Mine Host, John Anderson, of the Alcazar, well-known to all Ormond and Bretton Woods pilgrims.

Our radiator repaired, we made an early morning start for Ormond to catch up with the other racers. We were easily able to make the 50-mile run in 3 hours 35 minutes and to arrive at the Ormond Hotel for breakfast. Then we heard that Nolan had run into a tree and broken an axle five miles outside of Ormond in a race with Morgan to reach the hotel first. That early morning run to Ormond was beautiful. For ten miles out of St. Augustine top speed was possible over a magnificent shell road. Then we struck a stretch of wild country with more saw mills and turpentine camps. En route we ran across two or three of the automobile bridges erected by the senior Mr. White, who gives his name to the White Company. They consisted of two beams, each protected by plank sides to prevent the wheels running off into the ford. The wild country passed and arrived within ten miles of Ormond we struck better roads, fair country highways in fact, leading through the hummock land and beneath great white oaks hung heavy with Florida moss. Next we came to the good road, which ran for five miles along the beautiful Halifax river across meadows and past picturesque orange groves. We had a generous appetite for the breakfast to which our hospitable old friend, J. D. Price, ushered us.

There were good roads ahead of us much of the way to Rockledge, so we did not hurry ourselves to start early for our 74.5-mile run to Rockledge. It was noon when we crossed the Halifax bridge again and sped on our way over the well-known stone highway to Daytona. By the stores on the river front and beneath arboreal arches on the main street we journeyed joyously and then encountered the splendid road to Smyrna, which is 21 miles from Ormond. We swung down once more to the river and sped by great mountains of oyster shells constituting an inexhaustible mine of road material, and across a series of causeways to Port Orange, then over more of the beautiful river roads into Smyrna. The shell road continued to within five miles of Oak Hill.

We had had 28.5 miles of splendid going. We paid for it with rough roads and deep sands for seven miles. Then we entered the prairie at the head of the Indian river and made our way for a mile through tall grass up to the top of our dashboard. Shortly we plunged into the forest, and then followed twenty miles of riding whose beauty and novelty will long remain fresh in our minds. The run was over a hard bottomed and fairly smooth trail through a forest meadow. The tall, stately pines were scattered thinly enough for us to see a mile or more through them in all directions. We were enthralled by the sense of the forest's vastness and awed by the speaking solitude of our surroundings. The air was balmily cool and the green of the meadow pleasing to the eye. All the while the going was so good that we easily made the 20-mile run in an hour. Good roads greeted us through Titusville, where the entire population lined the streets to cheer us on our way. Out of Titusville we took the road leading along the Indian river. What a ride that was into Rockledge! For most of the way we were in sight of the majestic stream, whose other bank at this point was as distant and indistinct as is the Long Island shore from Connecticut. On its broad bosom floated white-winged yachts and saucy motor craft darted through its sparkling wavelets. Five miles from Rockledge we encountered an unbroken line of orange plantations with their pretty little cottages and boat houses in front of nearly every one of them. They impressed themselves upon us as the unostentatious homes of sport-loving men out for a good old winter time, loafing, sailing, boating and fishing.

Coco, a suburb of Rockledge, greeted us with waving handkerchiefs and raced with us in an opposition car to our destination at the New Rockledge Hotel. At this point we were first in the race. The Peerless had come from Ormond in 5 hours 25 minutes and had made a one-day run of 124.5 miles from St. Augustine in 8 hours 50 minutes' running time, which they say is a record for a run through Florida. Dr. Stinson

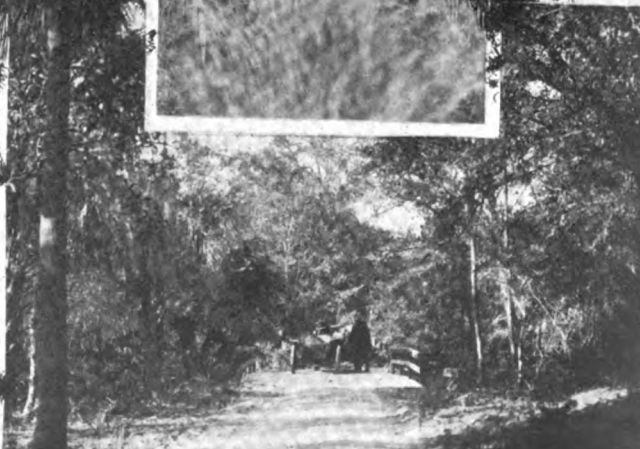
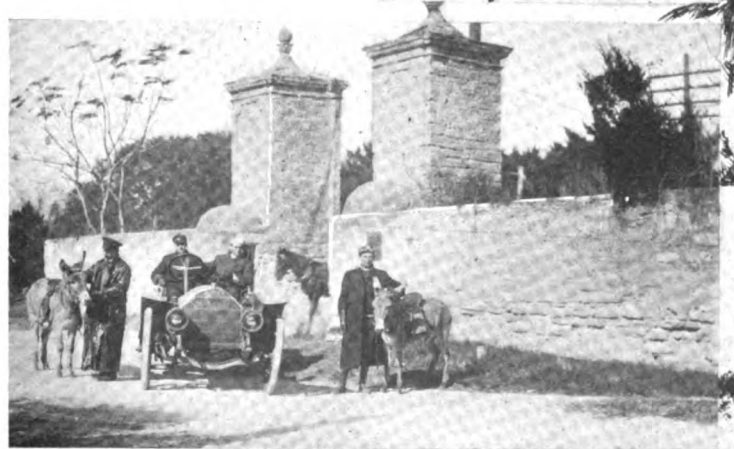



arrived with his Cadillac that evening, having made the 74.5-miles run from Ormond in about 7 hours 30 minutes.

Save for the 66-mile wind up stretch of fine coquina road from Palm Beach to Miami, the easy spots of our journey were now for the most part behind us. To be sure, we had nine miles of fairly good shell road in prospect at Melbourne, and shorter stretches of similar road at Sebastian and Eau Gallie. But for the greater part of the way there was sand to be ploughed through and rough forest trails to be tackled. Leaving Rockledge we had four or five miles more of good roads along the Indian river, past more orange groves, before we struck inland once more into the forest. At Grant, a settlement of less than half a dozen houses, they had erected a triumphal arch of flags and flowers and a dozen pretty girls were waiting with cameras to snap us as we passed beneath it. Mine Host of the resort hotel at Melbourne signaled us to stop and take aboard a basketful of toothsome luncheon. When we reached the Sebastian river Dr. Stinson, who had started a half hour ahead of us that morning, was about boarding the "county ferry." This was a scow fastened by rings to a wire stretching for a quarter of a mile or more to the opposite shore. In our honor, and for \$5 per car, a launch was on hand to tow the boat across. Normally it is a free ferry, each patron doing his own ferrying by pulling the boat across by the wire by hand. When the boat happens to be on the other side, the would-be passenger has to cross a distant railroad bridge and fetch back the boat. Claude Nolan had to do this at midnight. Remember, this is a wild country with an average of not more than three teams a day crossing the ferry. It was tantalizing for a "racer" to see his competitor sail away and get nearly a half an hour start before the boat placed his pursuer on the trail once more.

It was tough pulling in spots to get to Fort Pierce. In fact, on the very outskirts of our goal we were mired on the beach and had to dig and pull for a half hour to extricate ourselves. It had taken us eight hours to make the 75.4-mile run. At the Hotel Atlantic we forgot the food and lodging discomforts attendant on an excursion boat having swamped the town with travelers in the assurances of the sweet-voiced and sweet-faced daughter of the landlord that she knew that real gentlemen would not complain when they were told that they had done the best they could for them with the irresistible postscript, "Ah certainly do love New York, indeed Ah do, and Ah love New Yorkers too. They were so 'keind' to me and brother when we were there last summer."

The Fort Pierce folk tried to throw quite a scare into us about the day's run ahead of us to Palm Beach through the almost pathless forest wilderness. There was a labyrinth of entangled roads. There were morasses of mire. Strangers had been lost in the former and Laughlin had been stuck for two nights and a day in the latter. Despite all this, we disdained a guide and decided to go it alone and trust to the route book and signs Laughlin and Sebring had prepared for us. We certainly did have a time of it. We were in luck that it had not rained for several weeks or we would have had a worse time.

After less than five miles of riding we were once more in the heart of the forest with Jupiter 50 miles away and only one house intervening on the route. So far as the beauty of the surrounding pines and the balmy coolness of the air went, our ride through our first big forest was duplicated. This time, though, we had but a rough trail to follow. As we were bumping over the ruts and chugging through the sand in the heart of the vast forest we ran across a lone Seminole Indian. His pack of skins and camping outfit were hung on his back by a broad leather strap across his breast and a yachting cap surmounted his handsome pensive face; for these Seminoles are fine looking fellows. He carried his rifle swung across his forearm. He gazed with as near a look of silent wonder as an Indian can give at the strange devil machine; for this was Billy Tucker's first sight of an automobile. When we had convinced him in reply to his inquiry that a ride would cost him nothing, he climbed aboard with his pack. In answering his rather unsuc-

cessful interviewer, he said he had been out hunting and was on his way to his tribe at Lake Okeechobee, 25 miles away. He could walk 15 miles a day, he said. Despite the rough, miry road, we took him that distance in a little over an hour. When we reached that one lonely house in the forest, its truants were absent, but we invited ourselves to eat our lunch on the dining-room table and left a note of thanks for the owner's unwitting hospitality. Here Billy Tucker left us and struck off to the West to tell the denizens of the everglades of his wonderful adventure and doubtless be called a drunkard or a liar for his pains.

Now our troubles began for fair. Small lakes were quite frequent and mire almost incessant. One bit of it was too much for our motor and our muscles and we had to unship our block and tackle. It was a two hours' job to build a road of logs and palmetto leaves to give our wheels traction, while the Senator and the other three of us pulled for dear life on the ropes. An hour later we approached a pond. The guide book had warned us of a pond with a sign on the opposite side. This was it; but the sign, running parallel with our going, we did not see it from our side and so plunged into the pond. These ponds, remember, all have hard bottoms; some have deep holes requiring cautious navigation. On the bank to the right we saw the tracks of Dr. Stinson's car, and—alas!—followed them only to be mired just where he had been. In two hours, by digging and prying, we had made but six feet of progress. It was 6 o'clock then, and Wheeler, who had proved a giant of pluck and strength, was pretty well fagged out. It was a case of a night in the open. With our grips beneath our heads we slept the sleep of the weary, waking only at hour intervals to pile on more wood and draw nearer to the fire. We had to dig for drinking water.

At daylight we were awakened by Billy Harrison's shouting, "An automobile is coming." We could hear the chug-chug of the motor in the distance. No, we didn't have 'em, for in ten minutes Claude Nolan, who had started from Ormond a day and a half behind us, having waited that long for a new axle and having ridden for two nights and a day without rest, appeared at the other side of the pond. We warned him to stop. He had a guide with him. After a long conference and study of the ground, the Cadillac followed the directions of the pathfinders to keep on through the pond, swinging slightly to the right to avoid a deep hole and emerged in safety at the other side. Then came the job of getting the Peerless out of its predicament. The guide put through a plan that future tourists should remember. Our salvation was what he called a "Spanish Windlass." Let me tell you that it beats a block and tackle or a team of horses all hollow, and it is always available. There were no trees within reach, so 80 feet in front of the car he planted a stake, to which he fastened one end of the rope. Then half way between it and the car he planted another stake, around which he made a turn of the rope and a loop, into which he inserted a strong sapling pole he had cut. The other end of the rope was fastened to the axle of the car. Then two of us manned the sapling pole and walked around with it while two others pried up the car wheels with poles placed beneath the rear axle and hubs. We yanked the car out fairly easy.

"You can pull the bottom out of the earth with that," said the guide. He did not seem far wrong in the light of our experience.

Our subsequent troubles were as nothing compared to those just passed. After stopping an hour at Jupiter we set out for Palm Beach. It was a tiresome pull of 20 miles, fully one-half of it through deep sand. We emerged from the desert of Sahara and reached Palm Beach at 2 o'clock in the afternoon. The 66-mile run to Miami over the coquina road H. M. Flagler built two years ago, a highway familiar to many motorists by experience and most others by reputation, concluded the 372-mile run through Florida.

With stops at Ormond, Rockledge and Fort Pierce, the trip can be made in four days, though one had better count on five days, with a night's rest at Palm Beach, taking things in a little more leisurely fashion than we did during the race.

# The Motorist's Gate to the Continent

By Stenson Cooke

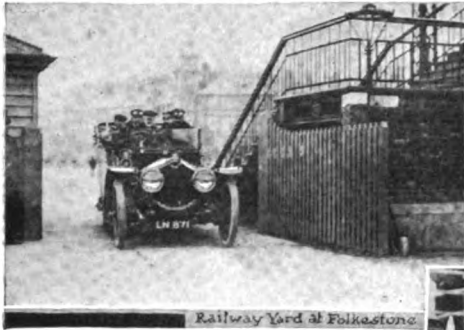

Railway Yard at Folkestone

[All motorists crossing to the Continent from England are aware of the tedious and irritating formalities to be gone through on arriving at the other side of the channel. By the intervention of the Automobile Association of Great Britain all difficulties have been swept away. Charles Jarrott recently tested the arrangements.]

“HELLO! H-e-e-e-l-l-o! That the A. A.? That the secretary? Charles Jarrott speaking! Say, you're shouting a good deal about this touring department of yours and I am inclined to see what it really can do.

“This is Tuesday morning—I leave the Motor Club, London, on Thursday morning after breakfast, catch the mid-day boat from Folkestone, cross to Boulogne, and reach the Franco-Italian frontier at—never mind. I shall drive a four-cylinder, dual ignition, 40-horsepower car—for further particulars see small bills, which will keep you posted as to the minor details. I want a *triptyque*, a *permis de circulation*, eighty liters of petrol, tickets, a deck cabin facing south, and twenty pounds in French money. And I want a hole cut in the tariff wall of France big enough for me to drive through with a maximum of ease and a minimum of delay. Now, if the A. A.



Placed on Steamer's Deck

Petrol Removed Before Embarking

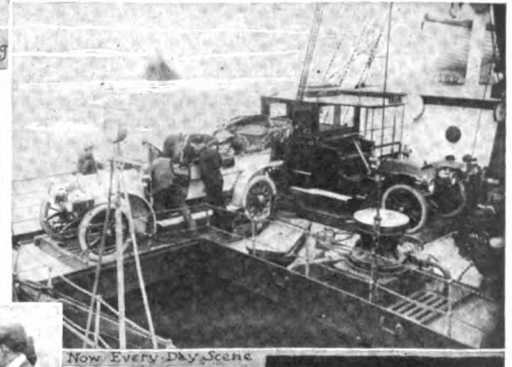

Now Every Day Scene

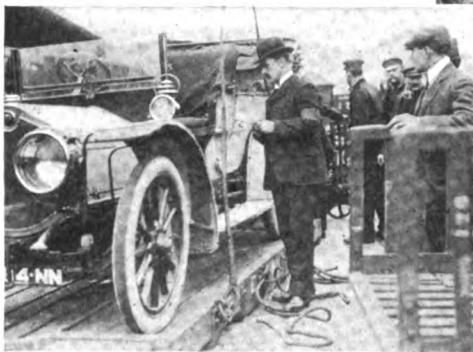

A.A. Representative at Boulogne



not seek the assistance of such societies as the A. A. nor subscribe to its funds—at a decimal point per centum.

bad, or indifferent, is mulct in certain deposits, not necessarily for publication, but as a guarantee of good faith, the said deposits being returnable as and when the car shall leave the shores of France.

The principle is not combated, but the practice is so intricate, so strangled with red tape, that one may with reason put the number of unattached touring motorists—i.e., those who do

The motoring societies make motoring and touring easy.

Instead of shivering in a cold, bleak *douane* signing mysterious papers and paying over mystical amounts in French coinage, with an irritating impression of having been “had” over the rate of exchange, to say nothing of the haunting fear that some breach of circumlocutory law may involve entire loss of

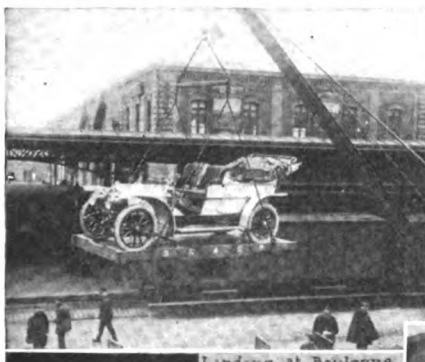

Landing at Boulogne

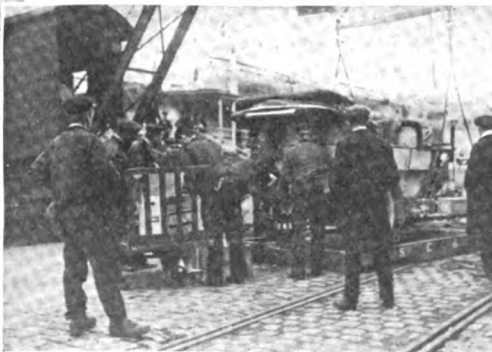

Petrol Supplied at Boulogne

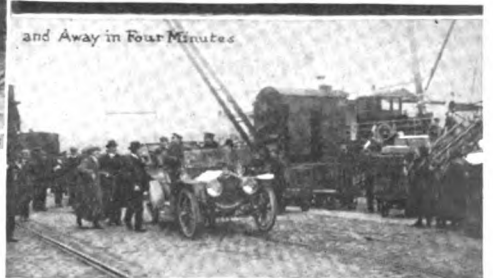

and Away in Four Minutes

touring department is all you say, let it establish a record, let it spread itself! I send you a cheque to cover deposits of duty, etc., and you do the rest. Now, make things hum! Good-bye!”

Be it explained here, for the edification of those who do not go down to the sea in motors, that foreign countries abound in tariffs. This is to say that you cannot sell an English or other strange motor car in France without first paying a duty of about a sovereign sterling per hundredweight “all in.”

And in order that the tourist shall not go behind this protection by means of specious explanations, every car, good,

the money, the A. A. member in search of sunshine finds every difficulty smoothed.

He wants to go to Bordeaux and Biarritz, via Boulogne? Very well. Forms printed in plain, simple language are ready for him to sign. Deposits are taken at the offices in Coventry street, tickets issued, seats engaged, petrol commandeered; in fact, he and his car are carried about with all the directness and without the unpleasant "school treat" feeling engendered by the ordinary touring bureau.

He waves his A. A. permits in the face of humbled frontier officials and goes on his way rejoicing.

The system being almost perfect, all that remained was to beat every other system in the way of application—in short, to add to the million and one odd records for everything under the sun that of "clearing" a motor car through Boulogne, timed by a stop watch, and this is how it was done.

Copy of telegram from the secretary of the Automobile Association to the Marine Superintendent, Southeastern Chatham Railway Co., Folkestone:

"Reserve space Charles Jarrott car A.A.6000 First Service Boulogne April 2nd arrives 11-30 leaves 11-55 Deck cabin South aspect self and friends Move"

Reply to Fanum, London: "Right."

From secretary Automobile Association to Major Stevens, Gare Maritime, Boulogne:

"Charles Jarrott and car A.A.6000 arrive Boulogne first service April 2 en route Italy wants clearance permis circulation but no license make violent love French Customs establish record want eighty litres essence."

Reply to Fanum, London: "Right."

Thus did it come to pass that on Thursday, shortly after noon, as the S. E. & C. R. turbine steamer *Queen* rocked lazily by Folkestone quay within twenty minutes of her scheduled starting time, "C. J.'s" "Forty" drifted quietly between coal trucks and empty baskets onto a neat contrivance called a "stage." She was attacked by four deck hands, who lashed the wheels to corner rings while two others drained the petrol tank. A derrick then swung the car aboard.

Gold-laced officials (the chief of whom, Captain Hatton, had arranged for everything) looked on with complacency; they had nothing else to do. Once on deck the car was made snug—French numbers replaced English ones, and polite officers showed the way to the deck cabin facing south—one of the only two aboard. Here were daily papers, motor papers, cigarettes, soda water, and other necessities of civilization. So much for Folkestone.

At about 1:20, English time, a small army of baggy trousered democrats stood watching on Boulogne landing stage as the nose of the turbine cut a long white mustache in the sea two miles away. At 1:33 her steam ladyship nestled comfortably by the landing stage. Thence time was measured by fifths of seconds.

Before Charles Jarrott's party had passed down the gangway the car was deposited on the quay. Men clad in blue overalls rushed to the petrol tank with cans of essence and a wide-necked funnel. Gold-laced prototypes of Folkestone fluttered about with papers, gesticulated, advanced, retired, and set to partners. The A. A. official ran here and there, persuading the petroliers, coaxing the customs, making himself generally indispensable. Amid all the bustle stood Major Stevens, *chef de la gare Maritime*, spick and span and imperturbable, the personification of "Bond street in Boulogne."

Thanks to his admirable engineering, the hole in France's tariff wall had been widened to pass an English car through complete with certified papers, signed permit, and fuel for nearly four hundred miles, in record time, for Charles Jarrott waved good-bye and headed due south at 1:37—exactly four minutes from the moment the boat stopped.

It is not exaggeration to say that this record will not and cannot be beaten at any other continental port. The completeness of the A. A. touring facilities and the whole-hearted attention of the Southeastern staff combine to remove practically every difficulty which motorists in search of sunshine have hitherto encountered.

There is only one gate to the Continent, and Major Stevens commands the guard. The countersign is "A. A."

## CHANGES IN FRENCH LAW AFFECT ONLY RECKLESS DRIVERS

PARIS, April 15.—There is to be a new automobile law in France, as everybody knows, but there is really no reason for the shrieking and protesting that have gone forth against the parliamentary work, for there will be no change so far as the average automobilist is concerned. Speed laws and regulations will remain as they are at present—generally a dead letter—registration is unaffected, and taxation has undergone no change. What parliament will do, supposing that the recommendations of the Public Works Commission are accepted, and there is every reason to believe that they will be, will affect only reckless and careless drivers. When an automobilist has been condemned by the judge of a criminal court to be deprived of his license, notification of the fact will be made by a central bureau to be appointed for that purpose, and neither by hook or by crook can a man so deprived obtain another ticket until the end of that time.

When this identification scheme was put forth it was proposed to record at the central office every condemnation pronounced against an automobilist, whether it was for running without a tail-lamp or for driving to the danger of the public, and condemn him to prison and the loss of his license for the third offense. This was manifestly unjust, for the three "offenses" might have been running without a tail-lamp, emitting too much smoke and using the siren in town. Now the indelible black mark will not be written down until the automobilist has been ordered to turn in his card to the proper authorities. Once the card is turned in, it will be impossible to enter an adjoining department and obtain a fresh ticket, for every licensing inspector must obtain assurance from the central office that the applicant is clear on the books

of that authority. Another detail modification which has its importance, instead of having to travel to the town in which he has been condemned, in order to personally hand over his driving card to the judge, the driver on the black list has the option of giving the ticket to the judge in the town in which he lives.

Under the first draft of the law a host of small employees were given power to summon automobilists for infraction of speed and driving regulations. Thus the humble stone-breaker on the roadside might have been making a note of your rear number to sent in to the police with a complaint that you had traveled past at 40 miles an hour; or the leisurely gamekeeper, with as little knowledge of motors and speeds as an infant, might have had the power of putting in an official complaint. This has been changed in the new recommendations, and only city police, gendarmes, officers in the Service of the Roads and Bridges, and engineers in the Service des Mines (the authority issuing driving licenses) have a right to interfere.

According to a circular just sent out by the Paris Prefect of Police, driving licenses issued in the district will in future cost \$4 each. Under the law in force for many years the only cost in connection with a license has been 12 cents for the stamped sheet of paper on which application is made. Under this regulation, power for which the Prefect declares is to be found in the financial law of last December, \$4 must first be paid to the tax collector before application can be made for a license. Workmen and servants earning less than \$40 a month can have the fee reduced to 50 cents. The regulation appears to apply to Paris and neighborhood only, all other parts of France remaining as before.



# Latest News

two series of 372 miles on the following Monday and Tuesday. All machines taking part must be stock

vehicles of a determined weight and displacement, and will be given a limited amount of gaso-

line for the distance to be covered. The fuel allowance will probably be 15 miles to the gallon, as last year.

In case a profit is made on the race a return will be made to each competitor, proportionate to the entrance fee paid. As the circuit will be in perfect order, as the result of the Grand Prix, equipped with grand stands, barriers, bridges, tunnels, etc., it will be extraordinary if the management cannot succeed in clearing a considerable amount of money. The date chosen is the most favorable for a paying event, being at the height of the Dieppe season, the first week in August also being the

English holiday season when hundreds of Britishers travel over to the shore resorts in this part of Normandy.

It is quite possible that British cars will be well represented in the French fuel consumption race, owing to the greatly renewed interest that British makers are taking in international sporting events on the road.

## H. S. HOUPT TO GO TO FRANCE WITH ROBERTS.

Harry S. Houpt, who gives his name to the company representing the Thomas interests in New York, has announced his intention to accompany Montague Roberts, who will alone represent this country in the next Grand Prix race to France, to act as his mentor and guide. No racing pilot has a more enthusiastic or sincere believer in his prowess than the youthful bearer of the Thomas racing colors has in this New York sportsman. Roberts carried the Houpt standard in the initial contest for places on the American Vanderbilt Cup team, and won what he strove for only to lose it through the committee's astonishing ruling that it had the right to go behind the results of the trial in the selection of the team.

Mr. Houpt's faith in Roberts was unbounded, and, largely through his urging, the young New Yorker was made the mate of Caillois and LeBlon in the elimination trials of 1906. In the 24-hour race at Brighton Beach last Summer, Roberts added force to Houpt's "I told you so" by winning. The present season he was chosen to pilot the Thomas New York-to-Paris car as far as Cheyenne, and now has been delegated to strive for added Thomas prestige in the Grand Prix. Others, in a word, seem to have come around to Mr. Houpt's way of thinking in the matter of confidence in "Monty" being rightly imposed.

Mr. Houpt will see to the engagement of training quarters for the Thomas one-man team, and will look after the practice for the big event. Not the least important factor in Mr. Houpt's decision to accompany Roberts abroad is his desire to be on hand to take part in the reception of the Thomas car at the conclusion of the New York-Paris race.

## WHAT ONE EX-VANDERBILT RACER IS DOING.

CLEVELAND, April 20.—Patiently plodding along, with no hope of plunging along the race course again, with its gasoline supply cut down so fine that it keeps within the speed limits, an old Vanderbilt Cup racer may be seen puffing along the streets of this city almost any pleasant day. It is the Frayer-Miller air-cooled racer, which once qualified for the Vanderbilt Cup. It is now in the possession of W. B. Drown, who has charge of an auto supply store, and every day attracts a curious crowd of "auto fans." Drown expects to enter this freak in the free-for-all event in the hill climb this Summer, and there is a chance that he may take it around the country, racing wherever possible.

PARIS, April 18.—An addition of three more cars to the long list of racers entered for the Grand Prix has been assured by the decision of the Mors company to come back to the racing field. The racing cars were built several weeks ago, but owing to financial trouble they were not entered, and when the date for receiving engagements at ordinary fees had passed, it was considered certain that they would not be seen on the Dieppe course. The Mors company has now declared that it will enter the cars at double fees before the end of May.

The three drivers who have been chosen are Jenatzy, who has definitely abandoned Mercedes; Charles Jarrott, the English racing automobilist; and Langon, chief tester at the factory, who made his first appearance on a car in the Moscow-St. Petersburg race last year.

The Mors racers are four-cylinder cars of the maximum bore and about 160 millimeters stroke. They are chain driven.

### Coupe de la Presse Also on Dieppe Circuit.

PARIS, April 18.—One month after the Grand Prix the Dieppe circuit will be the scene of another race, the Automobile Club of France having decided to hold its annual Coupe de la Presse on the fast triangular course in Normandy. A committee composed of members of the Dieppe municipality and deputies of the district waited on the Competition Committee of the A. C. F. last week, asked that the competition be held in their district and promised a subvention of \$2,000. Without wasting much time in discussion, the Club gave an affirmative reply, and announced the date of the competition as Sunday, Monday, and Tuesday, August 2, 3, and 4.

The Coupe de la Presse, the most important French touring competition of the year, will be remembered as the event that last year resulted in one of the most terrible accidents the automobile industry has ever known. One fatal accident on the road was followed by a more terrible one in which two cars traveling at 50 miles an hour met in a head-on collision causing the death of every person on board. The Government put a stop to the competition, and made it known that no more events would be allowed on the open road. It is because of this decision that the Coupe de la Presse, a touring competition based on speed and fuel consumption, is being held on a closed circuit.

Weighing-in will take place Friday and Saturday preceding the races, the small cars will compete over a distance of 372 miles on Sunday, August 2, and the heavy vehicles will run off



# THE AUTOMOBILE

Vol. XVIII

Thursday, April 23, 1908

No. 17

## THE CLASS JOURNAL COMPANY

Flatiron Building, Madison Square  
New York City

H. M. SWETLAND, President

### EDITORIAL DEPARTMENT

A. G. BATCHELDER, Managing Editor  
R. F. KELSEY, Associate Editor C. B. HAYWARD, Engineering Editor  
W. F. BRADLEY

### BUSINESS DEPARTMENT

A. B. SWETLAND, Business Manager  
LOUIS R. SMITH FRANK B. BARNETT  
W. L. RALPH, 1035 Old South Building, Boston, Mass.  
C. H. GURNETT, H. E. WESTERDALE, 1200 Michigan Ave., Chicago, Ill.

Cable Address - - - - - Autoland, New York  
Long Distance Telephone - - - - - 300 Gramercy, New York

### SUBSCRIPTION RATES:

United States and Mexico - - - - - One Year, \$3.00  
Other Countries in Postal Union, including Canada - - - - - One Year, 5.00  
To Subscribers—Do not send money by ordinary mail. Remit by Draft,  
Post-Office or Express Money Order, or Register your letter.

### FOREIGN SUBSCRIPTION AGENTS:

ENGLAND:—Hilffe & Sons, Limited, 29 Tudor Street, London, E. C.  
FRANCE:—Boyveau & Chevillet, 22 Rue de la Banque, Paris.  
GERMANY:—A. Seydel Monrenstrasse 9, Berlin.

Entered at New York, N. Y., as second-class matter.  
The Automobile is a consolidation of The Automobile (monthly) and the Motor  
Review (weekly), May, 1902, Dealer and Repairman (monthly), October, 1903,  
and the Automobile Magazine (monthly), July, 1907.

Copies printed in 1905 - - - - -	730,000
“ “ in 1906 - - - - -	791,000
“ “ in 1907 - - - - -	888,900

## A SEASON OF CONTESTS IN PROSPECT.

If the number of contests now being planned by clubs all over the country may be taken as a criterion, there is little doubt that interest in automobiling as a sport was never keener than at the present. For numerous reasons, the track long since proved itself a field to which the automobile is not so well adapted as it is to competing along other lines, so that it is only natural that contests gradually have assumed other forms. One of the most popular of these is the hill-climb; at least, to judge from the number of these now on the calendar, and some of them are events of several years' standing. As a means of calling attention to the capacity of the automobile to travel long distances, the endurance run is deservedly popular, and several prominent events of this character are scheduled for early dates.

The ease with which what primarily appeared to be exceedingly rigorous conditions were met by the competing cars almost without exception, taken together with the fact that the idea was so thoroughly threshed out all over the country, caused the sealed bonnet form of contest to lose some of the favor in which it was held after the successful outcome of the first event of the kind, long before the end of the season which gave it birth. But there will still be sealed bonnet contests galore for all that, as witness the fact that there are some of them down on the calendar now in different cities. The automobile gymkhana has yet to take that hold on popular favor here which is so generally ac-

corded it on the other side, and particularly in England, though some of the clubs here have held very successful affairs of the kind. Taken all in all, the coming season will be one of contests, great and small, from one end of the country to the other. The eagerness with which such events are looked forward to by their participants, and the generous audiences that they never fail to attract, afford striking evidence of the growth of popular interest in automobiling.

The program of national events is small in number, due to the fact that the manufacturers who really pay the cost of these expensive contests do not care to participate too frequently. Not only is the money expenditure to be considered, but the resulting interference with the routine of the factory is another thing that carries much weight. Therefore, due to an understanding between the manufacturers' associations and the A. A. A., there will be only two more national events this year—the Fifth Annual Reliability Touring Contest for the Glidden and Hower trophies, in July, and the Vanderbilt Cup race, either in October or November. These two affairs, with the numerous local events, will do much to accentuate the importance of the industry and pastime and assist in its greater progress.



## [CLEARANCE AS REGARDS HEIGHT OF BODY.]

One of the features that distinguished American cars of earlier days to their detriment, in more ways than one, was the extreme height at which the bodies were perched. This was erroneously regarded as representing an amount of clearance quite essential for traveling American roads, but the frequency with which some of those same cars got hung up on the differential, or struck some other part of their under work on obstructions, told quite a different story. A glance at what was considered to represent a design particularly adapted for rough road work often showed a car perched high in the air, with some of its most important essentials quite close to the ground, quite as close, in fact, as was true of much better-designed cars, the bodies of which did not serve to subject the car's tires to such terrific lateral strains, owing to their much lower center of gravity.

That American roads demand the maximum possible clearance consistent with good design, is something that cannot be controverted, but there are other equally inexorable laws of good designing, and one is that the center of gravity must be kept low. The higher the body is above the wheels, the higher the load must be carried, and this not only acts injuriously on the tires, but likewise reduces the safe speed of the car to a great extent. Last, but not least, the early American practice of placing the body high, regardless of the extent of the clearance, made an awkward-appearing machine, though few but experienced eyes could discern wherein the fault lay. Next to the high placed body, the one feature that makes a car look awkward and ill-proportioned is to have its radiator protruding forward of the front wheels. It is a matter of congratulation that the American designer came to realize that the little things counted some years ago, and that a car must have an attractive and business-like appearance, in addition to a capacity for reliability and endurance.

## A. M. C. M. A. LEASES GRAND CENTRAL PALACE FOR SHOW

THE American Motor Car Manufacturers' Association has leased the Grand Central Palace and will run its own show there next winter. This announcement followed a meeting on Tuesday in this city of the show committee of the A. M. C. M. A. and the Motor and Accessory Manufacturers, Inc.

The official statement given out from the headquarters of the office of the independents declared that the Automobile Club of America had withdrawn from show promotion and that the exhibition next winter would be entirely under the management of the A. M. C. M. A.; and then tacked on a polite postscript by way of a courteous farewell and an easy let-down that officers and members of the club would serve on the show committees.

Representing the accessory makers at the meeting were: H. S. White, Howard E. Raymond, D. J. Post, Fred E. Castle and W. M. Sweet. Those in attendance on behalf of the A. M. C. M. A.

were H. O. Smith, chairman; R. M. Owen and S. H. Mora, of the show committee, and Benjamin Briscoe, president, and Alfred Reeves, general manager. A member of the accessory association, which will exhibit at the show, will be added to the show committee.

Conferences followed with members of the Importers' Automobile Salon, Inc., with a view of having foreign cars once more included in the annual Grand Central Palace exhibition, it being very generally conceded that the success of last year's independent exhibit of imported cars at Madison Square Garden was not sufficient to give much encouragement to repeat the experiment next year.

It was given out that the dates of the next show would shortly be announced. It was said after the meeting that no date earlier than January was favored.

## CLUBS AND TRADE TO FIGHT NEW JERSEY LAW IN COURTS

NEWARK, N. J., April 20.—Organized automobilists in this State are to begin shortly a fight in the courts to test the constitutionality of certain provisions in the amendment to the New Jersey law recently signed by Governor Fort, and to other sections of the Frelinghuysen law of 1906 itself. The North Jersey Automobile Club has appropriated \$500, and cooperation is already assured from the New Jersey Automobile and Motor Club, the Automobile Club of Hudson County, and the New Jersey Automobile Trade Association. It is expected that other clubs allied to the Associated Automobile Clubs of New Jersey will join in the movement. In fact, it is inferred that George A. Post, a leader of the North Jersey Automobile Club, who has been chosen president of the State association, will call upon that organization to father and direct the legal battle, in cooperation with the State Trade Association.

One of the chief grounds of complaint is the fact that the law seeks to raise revenue for road repairs and the like by automobile licensing. The automobilists do not object to supporting the Department of Motor Vehicles by paying licenses, but argue that they already contribute toward road repairs by paying taxes on their cars as personal property. This they insist is unfair discrimination in favor of other users of the high-

way. There are several points which are believed to be vulnerable to attack and are naturally withheld from publication to avoid disclosing the probable lines of attack on the constitutionality of the law.

That the State Federation of Automobile Dealers will also join in the fight is emphatically stated by George Paddock, its president, who declares that the fight in the courts is but a part of the campaign his organization is starting.

"We are willing to join the automobile clubs," said he, "to test the constitutionality of the Frelinghuysen measures. There are two features for which we intend to fight. First, the recognition of foreign licenses in a reciprocal way; that is, to residents of such States as recognize the New Jersey numbers; second, the increase of the speed limit to 25 or 30 miles per hour. If, in attempting to gain these, we are able to work other reforms, so much the better.

"Motorists all over the State seem to think that bad faith has been shown by Senator Frelinghuysen and others in dealing with representatives of the automobile organizations, and that only by an appeal to the courts can justice be obtained. When the fight does start the best legal advice will be sought and no expense will be spared in carrying the case to a finish."

## THE FEDERAL BILL IS NEITHER DEAD NOR DOOMED

WASHINGTON, D. C., April 20.—Automobilists, if they are laboring under the impression that the Federal Registration bill is either dead or doomed to die, want to disabuse their minds of any such erroneous idea. The American Automobile Association through its State organizations, its clubs, and its influential members is quietly at work answering the criticisms of its opponents concerning the constitutionality of the measure and bringing to bear arguments in its favor upon the members of the Judiciary Committee, which has the bill in charge.

An effort is being made to prove to Congressman and Chairman J. J. Jenkins that he was a bit hasty in the opinion he voiced in an interview, previous to the hearing on the bill, that the proposed law is unconstitutional on the ground of interference with the police powers of the States, and to impress upon him the force of the arguments advanced by Chairman Charles Thaddeus Terry, of the A. A. A. Legislative Board, at the hearing in question.

The Wisconsin State Automobile Association has taken upon itself to let Mr. Jenkins know what a large contingent of his

Badger State constituency thinks of the advantages of a Federal Registration law. Accordingly, last week Neal Brown, president, and James T. Drought, secretary, of the Wisconsin association, conferred with Mr. Jenkins in Washington. Mr. Brown having formerly been a State senator was thus aided in obtaining a patient and courteous hearing. Mr. Drought was emphatic in his statement that the bill was favored by every automobilist in Wisconsin and stoutly maintained that its provisions were merely a matter of identification and did not interfere in any way with the police power of any State.

"This measure," said Mr. Drought, "has both simplicity and clearness to recommend it. It does not violate the police power of any State. The sole purpose of the bill is to provide for registration and identification of motor vehicles engaged in interstate travel, so as to give to the owner of such vehicle the right of free ingress and egress in the various States of the nation without further registration and identification."

Chairman Terry was also in Washington during the visit of President Brown and Secretary Drought, and it is safe to say that the bill's chances have improved materially in the past week.

## BRIARCLIFF RACE TO-MORROW.

The stock car chassis race for the Briarcliff trophy is scheduled to be run to-morrow over a course whose odometer measurement is 32.4 miles. The number of laps set to be covered is ten, though there is a bare possibility that, owing to difficulties the route presents and the doubt that exists as to the ability of the drivers to complete the race within the time limit of 8 1-4 hours set for the use of the roads, the officials may decide at the last moment to reduce the distance to 8 laps, or 259.2 miles. It is planned to start the race at 4:45 A. M., the twenty-two contestants being sent away at one-minute intervals.

### Michelin Offers Two Complete Prize Series.

Both for the entrants of the winning cars in the coming Briarcliff trophy race, to be contested to-morrow, as well as for their drivers, the Michelin Tire Company is offering a complete series of prizes, amounting to \$2,250 in all. The only conditions

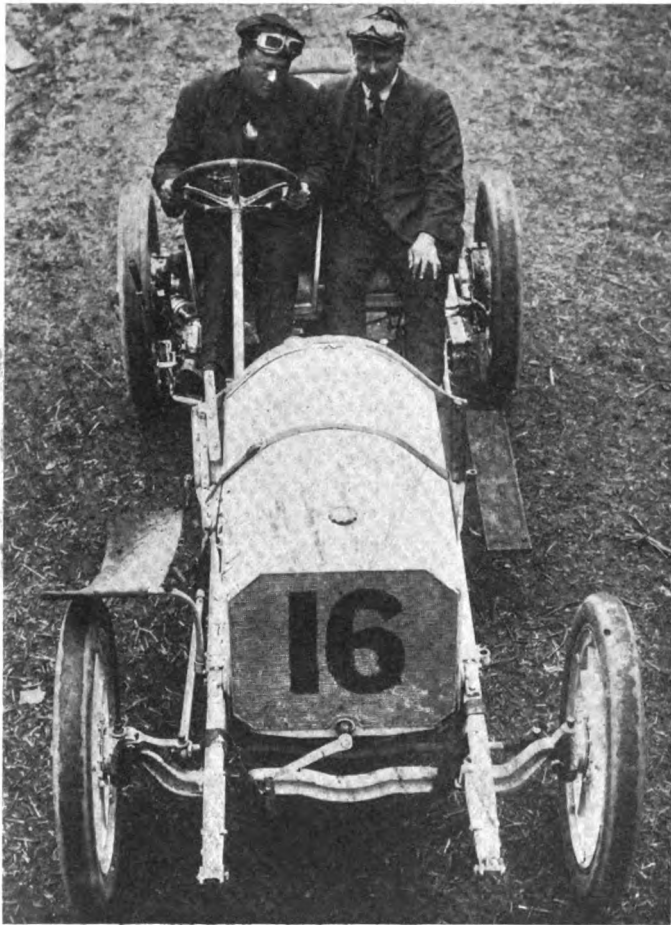

W. M. Hilliard and Hol-Tan-Shawmut Briarcliff Entry.

This car is a new quantity in racing, and its showing will be attended with much interest. Hilliard is one of the most experienced drivers in the country, though it is recognized that he is greatly handicapped with a car that has yet to be tried out. His most notable victory was the Mount Washington Climb of July 18, 1905.

are that the winning cars be equipped with Michelin tires. The first prize is \$500 in each case; second, \$300; third, \$150; fourth, \$100, and fifth, \$75, so that if the first car to finish be equipped with Michelin tires, it will be able to claim \$1,000 of the prize money, this amount being distributed equally between the entrant and the driver.

### E. V. Hartford Adds to Briarcliff Prizes.

One of the latest additions to the already substantial list of prizes offered to the winning drivers in the Briarcliff trophy race, is the sum of \$200, to be taken in cash or plate, which will be given by E. V. Hartford, president of the Hartford Suspension Company, to the winning driver in the race, provided his car is equipped with the Hartford-Truffault shock absorbers.

## PEOPLE WHOSE SAY-SO IS GOOD.

**A. C. Newby, President National Motor Vehicle Company, Indianapolis, Ind.**—"The automobile business in the West is good. While there has been a falling off in the volume of sales in the big cities, it has been pretty well offset by an increased demand in the smaller towns. That the interest aroused by the six-cylinder proposition at the shows has been sustained is proved by the proportion of the demands by buyers."

**Charles B. Shanks, Sales Manager, Winton Motor Carriage Company, Cleveland, O.**—"Will we continue our exclusive adherence to six-cylinder car production? We certainly shall. The strongest argument with us is the readiness with which Winton customers have accepted the considerable advance in price the cost of manufacturing 'sixes' has entailed. Mr. Winton is so well satisfied with the outcome of his present six-cylinder design that he contemplates only trifling changes, if any, next year."

✓ **H. H. Franklin, President H. H. Franklin Mfg. Co., Syracuse, N. Y.**—"Will automobile prices be lower next year?" is quite a general question. It is my opinion that the average price will be lower, but this does not mean that the price will be cut. It means that there will be more automobiles at a lower price. There will continue to be demand for the large high-priced machines, but this demand will decrease, rather than increase, whereas the demand for the moderate-priced and powered car will increase. The very big and excessively high-powered machines will gradually disappear, and in their place will be lighter, lower-powered machines, but because of refinement and reduced weight they will be as speedy."

**C. G. Stoddard, Dayton Motor Car Company, Dayton, O.**—"Popularity, practicability, and perfectness have all combined to make the sliding gear transmission almost universal. The sliding gear gives a wide range of speeds, permits direct drive on the high or any intermediate speed without the other gears running, and thus gives, in a satisfactory manner, and with little friction, wide ranges of vehicle control. With the high-grade steel and hardened and ground gear teeth now used by many, the gears are double, and, being encased, run with the least possible loss of power, are protected from damage by outside obstacles, are out of sight and out of mind, and give the best of service in almost every instance, the exception being when some mechanical defect exists. In brief, the sliding gear transmission is reliable, strong, simple, and durable."

**Frank Briscoe, Brush Motor Company, Detroit, Mich.**—"Discrimination in freight rates by the railroads is one of the predominating drawbacks of the automobile industry. Especially is the matter of freight rates discouraging to the maker of small cars and buggyabouts. There is no sane reason why the automobile should not be shipped as cheaply as carriages. The small cars could easily be knocked down, the body and running gear shipped as a carriage and the motor billed as an engine, just as marine engines are shipped; thus saving the buyer a snug little sum on transportation rates. The freight and transportation committee of the American Motor Car Manufacturers' Association have this matter in hand, and should be supported by all manufacturers of cars, regardless of trade affiliations. When the freight rates are amicably adjusted, then the first cost of the automobile will be materially reduced."

## CLEVELAND TO HAVE OAKLAND TAXICABS.

CLEVELAND, April 20.—At last it has been definitely settled that this city is to have taxicab service, and a company is being organized to hurry matters along. The Oakland, a car new in this city, will be the one used in the cab service, and arrangements are now under way to bring a large number of these vehicles here. Quarters have been secured at the Metropolitan Car Co. The original idea was merely to establish an agency for the Oakland in this city, but after two or three trips to the Oakland factory at Pontiac, Mich., Milton A. Hughes became convinced that the taxicab field was one needing attention.

## WHAT IS GOING ON AMONG THE CLUBS.

### HARTFORD CLUB IN PERMANENT QUARTERS.

HARTFORD, CONN., April 20.—The Automobile Club of Hartford is now located in permanent quarters in the Allyn House. President Fuller has announced that hereafter the club lunches will be held on Fridays instead of Wednesdays. The clubroom will be in charge of the assistant secretary and visiting motorists will find the latch string out and every courtesy will be extended to them. The local club now has what it has required for a long time, a home of its own in the midst of most congenial surroundings.

The contest committee of the automobile club Saturday made a preliminary run over the course selected for the endurance run of May 16. T. Dudley Riggs, with his 70-horsepower Simplex runabout, blazed the way. S. A. Miner provided a 30-horsepower water-cooled Knox, also a 22-horsepower two-cylinder Buick; R. D. Britton was on deck with the little two-cylinder Maxwell, and T. Dudley Riggs also provided a Simplex touring car. "Len" Fiske was much in evidence in the water-cooled Corbin. Start was made from City Hall at about 11:15 with Middletown as the first stop on the route. After a short stop the run was continued to Meriden, and the roads between the two points were in some spots poor. From Meriden the trip was continued to Southington and Waterbury, and the run over Southington Mountain was a little strenuous as the roads have not yet been put in shape. Waterbury was reached and stop was made at the Elton for lunch, and the trail blazers had a merry time of it. On the way to Bristol every car in the procession easily disposed of Plymouth Hill, one of the toughest and steepest grades in the State. Bristol was made without incident, and the run was continued to New Britain. Here it was decided to continue on the Farmington and Avon instead of going direct to Hartford. The run over the Avon Mountain was rendered the more difficult owing to the heavy rain, which started to fall when New Britain was reached. When the party rounded up at the Miner garage it was agreed that when two circuits of 87 miles had been made of the route traversed, the average driver of a car would feel that he had had about all he wanted for one day. The time of the Simplex, the largest car in the run, was 3 hours 30 minutes, that is actual running time for the 87 miles.

### PIKE CAMPBELL PRESIDENT LOUISVILLE CLUB.

LOUISVILLE, KY., April 20.—George H. Wilson, who has been president of the Louisville Automobile Club for four years, has retired from the office. Pike Campbell has been chosen in his place. The other officers elected at the annual meeting were: First vice-president, J. H. Ross; second vice-president, J. B. Lewman; secretary, Eugene Strauss; treasurer, Walter Kohn. Prince Wells was elected a director in the Kentucky State Automobile Association.

Various reforms and plans for the future were discussed at the meeting. W. O. Barnie, who has recently joined the club and is a member of the Board of Park Commissioners, promised to use his best efforts toward securing for automobilists their rights in the parks. An effort will be made to have the toll rate on the Kentucky and Indiana bridge reduced.

A tour to Frankfort for the annual meeting of the Kentucky State Association was proposed and favored.

### LAND AND WATER MOTORISTS FORM CLUB.

PADUCAH, KY., April 20.—The Paducah Automobile Club has been formed and chosen the following officers: President, Joseph R. Grogan; first vice-president, Fins Lack; second vice-president, P. H. Stewart; secretary, Roy O. Gressham; treasurer, Richard Ruddy. These with Jesse Weil and Benjamin Weile constitute the board of directors. The club starts with 30 members, included among whom are owners of gasoline launches and motor-cycles. It is planned to join the A. A. A. State Association.

### CONTESTS FOR THE TWO CHICAGO CLUBS.

CHICAGO, April 20.—Tentative routes for the 1,200-mile, four-day reliability test of the Chicago Motor Club, which will be run June 24-27 inclusive, have just been issued. As outlined by Chairman Root, the contestants will be required to cover 1,184 miles in four days, or an average of 296 miles a day. The routes in question take in everything within a radius of 150 miles of Chicago. More than 100 prominent towns are included, besides 100 smaller places. Average of 292 miles the first day, 322 miles the second, 279 the third, and 291 miles on the fourth day are indicated by the tentative routes now under consideration.

Another event, scheduled to take place June 6, is a roadability test, similar to the one run in Philadelphia on April 11. The Chicago Automobile Club has decided to promote this contest in connection with the club run to Gary, Ind., to inspect the steel mills now in course of construction there.

### ENDURANCE RUN FOR NORTH JERSEYMEN.

PATERSON, N. J., April 20.—George A. Post, who has been elected president of the Associated Automobile Clubs of New Jersey, has retired from the presidency of the North Jersey Automobile Club. Robert Beattie, of Little Falls, has been chosen in his place. The other officers elected at the annual meeting were: First vice-president, Dr. J. H. Faulkner; second vice-president, Benjamin Eastwood; secretary and treasurer, James Madden, Jr., of Little Falls; captain, Dr. George E. Layton; first lieutenant, W. B. Froude; counsel, Jacob Vanderclack.

It was decided to hold an endurance run on Saturday, May 16, consisting of four laps of 25 miles each, the contestants entering the suburbs of Paterson on each lap. The contest will be on a stop penalization basis. Each car will carry an observer.

### BAY STATERS WILL HOLD MAY 30 RACES.

BOSTON, April 18.—The Bay State Automobile Association's racing committee has decided to hold the annual race meeting of the association on Memorial Day, May 30, at the Readeville track. The plans for the races have not yet advanced far enough for any of the particulars to be decided, but the committee has begun the work of preparation.

Another important local event which was decided this week is a general meeting of the Massachusetts State Automobile Association to be held in Boston on Saturday, May 2. President William H. Hotchkiss, of the A. A. A., has been invited to attend.

### MORE CLUBS FOR CONNECTICUT ASSOCIATION.

HARTFORD, CONN., April 20.—There is a desire to form an automobile club in the town of Manchester, ten miles from Hartford. There are many cars in the town, and it is quite likely the organization will be effected in time to join the Connecticut State Automobile Association. If such a course is followed the matter will be brought up before the meeting of the board of directors, who meet at the New Haven House, New Haven, April 22.

WILLIMANTIC, CONN., April 20.—As the result of the efforts of a small body of progressive autoists, the Willimantic Automobile Club has been organized with a charter membership of 25. The officers are: President, Dr. John Weldon; vice-president, J. B. Fullerton; secretary, L. B. Lincoln; treasurer, E. F. Whitmore.

### OHIO BODY REVIVIFIES COLUMBUS CLUB.

COLUMBUS, O., April 20.—At a meeting of the more enthusiastic motorists of this city held here last night, the Columbus Auto Club, long since defunct, was brought to life. When fully organized, the local club will have a membership of over 250 and will be an active member of the Ohio State Automobile Association of the A. A. A.



## NEW PACKARD MAKES ITS DEBUT IN COMMERCIAL FIELD

**A**FTER having worked on the problem of the medium capacity commercial truck of the gasoline-driven type for five years, the Packard Motor Car Company, Detroit, Mich., is now placing on the market the result of this development. It goes without saying that it embodies all the time-tried features of Packard

storage battery and single vibrator coil, while the Packard circulating system of lubrication is employed complete. Control is by means of a throttle lever on the steering wheel, a pedal accelerator and an automatic governor. In fact, when it is said that the newcomer is essentially Packard, that suffices to describe

it, as the entire transmission is designed along the same lines as those that distinguish the same part of the Packard car. The same internal expanding type of clutch is employed, with a propeller shaft drive to a three speed and reverse sliding change gear, combined with the differential in a special housing, together with a countershaft. From the latter final drive is by means of side chains to the rear wheels.

The braking system is similar to that of the pleasure car, the running brake being pedal-operated, while a hand lever is employed for the emergency. The front wheels are 34 inches in diameter, shod with four-inch solid tires, while the rear are 36 inches and shod with four-inch tires. The wheelbase is 144 inches and the tread 68 inches. Exceptionally large and heavy steering knuckles are provided, the front axle

being a hammer-forging from solid steel. The platform back of the driver's seat measures 6 feet by 12 feet 4 inches, giving 74 square feet of floor space, which is of hard wood, shod with iron protecting strips. The weight of the chassis is 5,000 pounds and the maximum speed 12 miles an hour. The finish is Packard blue and cream yellow, and the truck lists at \$3,850 complete, with stake body, special types being supplied to order.

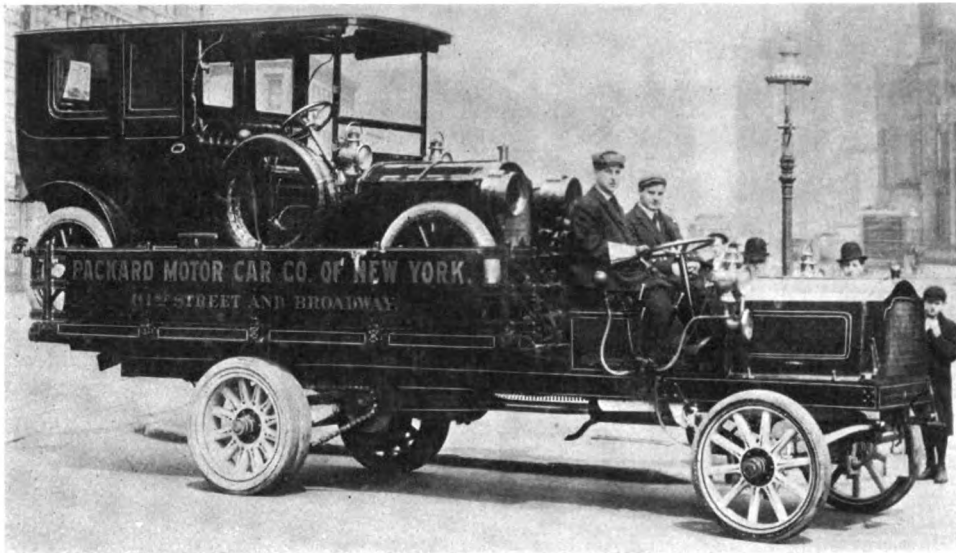

New Representative of the Packard Line in the Commercial Field.

construction, modified to meet commercial vehicle requirements. This new Packard truck has a capacity of three tons and is designed to be serviceable over a wide range of hauling, as it provides ample carrying space.

Its power plant consists of a 41-2 by 51-2-inch, four-cylinder motor, with a Packard type water-jacketed carbureter, a high-tension Eisemann magneto for ignition, supplemented by a

## STUDEBAKER ADDS SUBURBAN MODEL OF PLEASING LINES

**A**S has been the case all along where the lines of the Studebaker chassis are concerned, the designers have adhered to conservative models in body building as well, and the Studebaker is one of the last to yield to the demand for a type other than those that have prevailed as standard for some years past. To comply with this call for something that is neither a runabout nor a touring car, but one that combines the light weight and smartness of the former with the extra seating capacity of the latter, a new model, the pleasing lines of which are shown by the accompanying photograph, has been added to the Studebaker family.

It has been given the title of the Studebaker "Suburban," and is built on the same 30-horsepower chassis as the Studebaker Models A and H. The body of the car is considerably shorter than the regular touring type of the same power, and this, together with the low side doors, gives it a very smart appearance. As will be noticed in the illustration, special provision is made for carrying a

trunk in the rear, and, while the car has been particularly designed for what is familiarly known as "suburban service," comprising trips between the railway station and house, it is evident that it would also form an excellent car for touring, owing to its light weight and ease of handling.

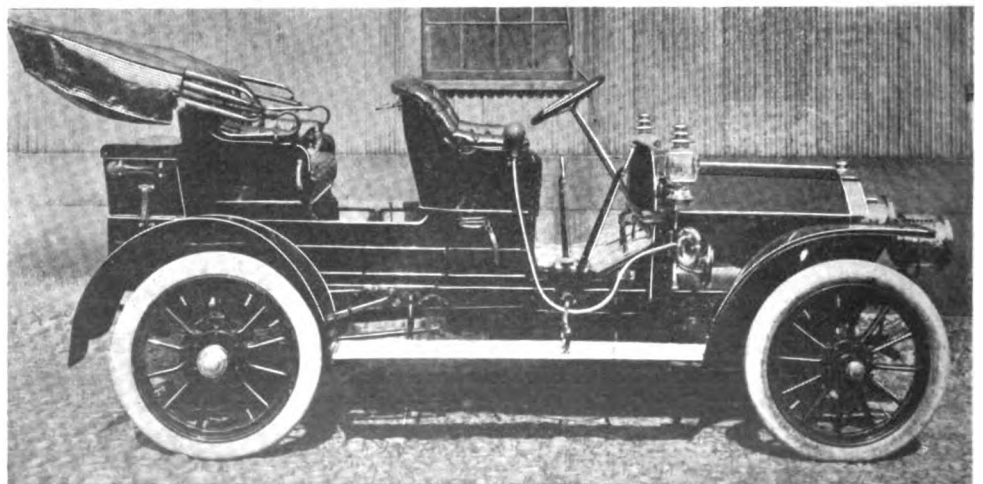

Pleasing Lines of the New Studebaker Four-seated "Suburban."

## BRIEF ITEMS AND TRADE MISCELLANY

The idea is unique, in that the magazine will contain many unbiased articles prepared by physicians for the benefit of fellow members of the profession who may be considering the purchase of cars.

The St. Joe Motor Car Company, Elkhart, Ind., has begun operations at its factory on Main and Simonton streets, with a force of 15 men. This is the concern that purchased the assets of the defunct Shoemaker Automobile Company, which recently went into the hands of a receiver.

The St. Louis Car Automobile Company, of New York City, has been incorporated with a capital stock of \$20,000. The organizers are John F. Valieant, Louis A. Hopkins and Walter S. McCall. The concern is the New York representative of the St. Louis Car Company, St. Louis, manufacturers of the American Mors.

In the notice which appeared in a recent issue concerning Gre-Solvent, the address of the manufacturers, the Utility Company, was wrongly stated. Instead of 332 Broadway, it should have been given as 636 West Forty-fourth street, where the factory and executive offices of the company have been located for some time past. Requests for free samples should be sent to this address.

Physicians in all parts of the United States are now cooperating with Thomas B. Jeffery & Company in the preparation of a special physician's number of the *Rambler Magazine*, which will appear on the first of May. This number will be written, edited and profusely illustrated by the efforts of American doctors who have used the Rambler in their practice for years.

Thomas W. Lawson, the Boston banker of "Frenzied Finance" fame, has just become the owner of a 50-horsepower, 1908 Matheson touring car. The sale is quite a sheaf in the cap of the builders of the Matheson, as with his accustomed thoroughness in doing things, Mr. Lawson has had a corps of experts examining and testing most of the prominent makes of foreign and American cars for some time past.

In the series of portraits of the competing drivers who will take part in the Briarcliff trophy race to-morrow, and which was published in last week's issue of *THE AUTOMOBILE*, Michener and Mulford were erroneously put down as handlers of Stearns cars, whereas they will handle Loziers in the race, both drivers having figured prominently on numerous occasions at the steering wheel of the Lozier.

The Thomas Detroit *Snow Bird* that made a successful 3,000-mile midwinter trip, minus all its gears, returned to Detroit last week where it received a rousing reception. It is entered in the Detroit endurance run, April 29-May 1, and after the completion of the latter, it will again go to Chicago, where it will take part in the Algonquin hill climb. From Chicago the car will go to Wilkes-Barre, where it is entered in the Giants' Despair hill climb.

During the past week all the Cleveland factories have been busier than ever before at this time of year. This is true of all makes of cars—gasoline, steam, and electric. The Peerless Company's statement for March shows that that concern is far ahead of the business done a year ago in

the same month, while the F. B. Stearns Company, through its purchasing department, is laying in supplies to build 20 per cent. more cars than it originally intended. These are but instances, but they show the trend of business conditions.

Two or three weeks ago, the Warner branch office in Detroit, located at 239 Jefferson avenue, was broken into and over \$1,200 worth of Auto-Meters stolen. George Weidner, the Detroit representative, did some "sleuthing" on his own account, and traced the burglar to Cleveland, where he was arrested. He confessed to having sold the loot to Robert Wachmann, of the Wachmann Motor Manufacturing Company, Detroit, for \$18. Upon being granted immunity, Wachmann confessed, and the Auto-Meters were found buried in a lot of hay in the rear of a store.

The Swinehart Clincher Tire & Rubber Company, of Akron, O., has begun an action in the United States District Court in Cleveland against the Motz Clincher Tire & Rubber Company, of Akron, asking an injunction to restrain the defendant company from manufacturing and selling tires bearing the side indentation feature. This the Swinehart company asserts is covered by Patent No. 826,622, granted to J. A. Swinehart. The side indentations are used on solid tires to secure greater resiliency. Damages are also asked by the Swineharts. This is one of several similar suits by the Swinehart company against the Motz company.

### RECENT TRADE CHANGES.

The New York office of the Duff Manufacturing Company, of Allegheny, Pa., has been removed from 26 Cortlandt street to the Hudson Terminal-Fulton building, 50 Church street.

C. S. Henshaw has just opened his new headquarters at 288 Columbus avenue, Boston, Mass., which building he previously occupied for three years. He will represent the Haynes Automobile Company, Kokomo, Ind., in the New England territory.

Another change of the Thomas representation in Philadelphia took place last week, when H. L. Lane was made manager of the L. J. B. Motor Car Company, local agents, at 139-141 South Broad street, succeeding "Joe" Keir, former Renault agent.

The Traver Blowout Patch Company has just removed to its new quarters in the Thoroughfare building, 1779 Broadway, New York City. The company has also been reorganized, the officers now being, president, James Caffrey; treasurer, M. L. Nuemoegen; secretary, L. T. Walter, Jr., and manager, John F. Sussillo.

### NEW AGENCIES ESTABLISHED.

Theodore Crossley has been appointed agent for the Oldsmobile line at Riverside, Cal., and the neighboring territory.

The Cuyahoga Motor Car Company will in future act as the agent of the Studebaker line in the East End, Cleveland, O.

When the Fairmount Engineering Works removed its factory from Philadelphia to Pottstown some weeks ago, it became necessary to arrange for the representation of the Chadwick car in Philadelphia

through an agency. Last week a deal was entered into with the Wildman Motor Car Company, of 254 North Broad street, to handle the Chadwick line in the Quaker City and vicinity. It is the first appearance of the Chadwick in a "Row" establishment, the Philadelphia retailing end having hitherto been carried on at the old Spring Garden street factory.

C. G. Bleasdale, factory representative of the Maxwell-Briscoe Motor Company, has placed the agency for the Maxwell line with the Ohio Motor Car Company, in Euclid avenue, Cleveland. This will be converted into a new Maxwell branch, and will be known as the Maxwell-Briscoe-Cleveland Company, and will be under the management of Mr. Bleasdale, assisted by G. F. Russell. Mr. Bleasdale has had temporary quarters in the Tabernacle garage for some time past and has placed several agencies in the State, besides one in the East End, with the Wentworth Motor Car Company.

### PERSONAL TRADE MENTION.

F. W. Walters, formerly with the Pennsylvania Rubber Company as general sales manager, has resigned his position with that concern.

John Wilson Drown, formerly publicity manager of the Corbin Motor Vehicle Corporation, has accepted a like position with the Standard Roller Bearing Company, of Philadelphia.

Russell H. Baldwin, formerly with the Connecticut Electric & Telephone Company, Meriden, Conn., has recently gone with the Timken Roller Bearing Axle Company. Mr. Baldwin is a valuable addition to the Timken sales organization.

G. B. Sharpe, advertising and publicity manager of the Garford and Studebaker companies, will remove his offices from South Bend to Cleveland, O., where he will be associated with Al Davis, sales manager of the Garford Company.

W. H. Yule, assistant manager and one of the directors of the Badger Brass Manufacturing Company, has recently resigned from that company and accepted a position with the B. F. Goodrich Company, Akron, O. In his new capacity Mr. Yule will be the manager of the Haskell golf ball department. Mr. Yule is a Harvard man and has long been prominently identified with the sport of golfing.

### WILLIAM L. GROUT DEAD.

GREENFIELD, Mass., April 20.—William L. Grout, the wealthy sewing machine manufacturer, died here at the age of 75 years. Mr. Grout began business something like half a century ago, at Templeton, with Thomas White, later of the White Sewing Machine Company, on a joint capital of \$400. A few years ago, he backed his sons in the business of building automobiles, the car being known as the Grout. Steam cars were first turned out, but they were abandoned later, and a gasoline car assembled. Last year, Mr. Grout objected to the manner in which the business was being handled and withdrew his backing. The sons then separated, Carl Grout now being in Boston; Fred Grout in Oklahoma, and C. B. Grout in Los Angeles, Cal.

INFORMATION FOR AUTO USERS

**Atwater Kent Gasoline Measure.**—This consists of a 12-inch boxwood scale which is graduated in inches and may be used to determine the depth of fuel in a tank. It is shellacked to make it proof against the action of the gasoline, and the black strip is given a gasoline-proof dull finish, resembling the surface of a blackboard and turning glossy when wet, thus showing clearly how high the fuel is. Carrying one of these measuring sticks in the tool box avoids the necessity of resorting to the first thing that comes handy with which to measure the amount of fuel, thus introducing dirt into the tank. These gasoline measures will be supplied gratis to any automobile owner upon request, by the Atwater Kent Manufacturing Works, 50 North Sixth street, Philadelphia, Pa., manufacturers of the well-known Atwater Kent spark generator, an ingenious piece of ignition apparatus that has come prominently to the front of late, through its good showing in efficiency tests.

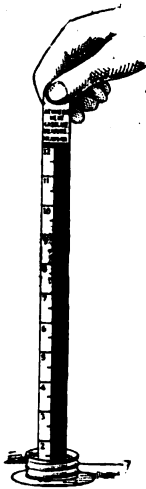

ATWATER KENT FUEL METER.

**Cleveland Spark Plug.**—This is a new type of spark plug, one of the most striking features of which is the spiral, doubly-insulated core. According to the manufacturers, the Cleveland Spark Plug Company, 940 Power avenue, Cleveland, O., the spiral terminal of this core has two functions. Owing to its peculiar form, it is claimed to act as a condenser, greatly intensifying the heat of the spark, with a decrease in current consumption. It also sets up a centrifugal whirling action of the burnt gases, depositing the carbon on the inner wall of the outside shell. Another important feature, according to the makers, is the auxiliary combustion chamber, which "shoots a flame" into the mixture in the combustion chamber, thus insuring complete combustion of the charge and maximum output of power. Only the very best materials are employed in its construction, while every part of the plug is finished to micrometer gauge, thus insuring a perfectly gas-tight fit. Mica is employed for the insulation of the spiral core as shown by the accompanying illustration.

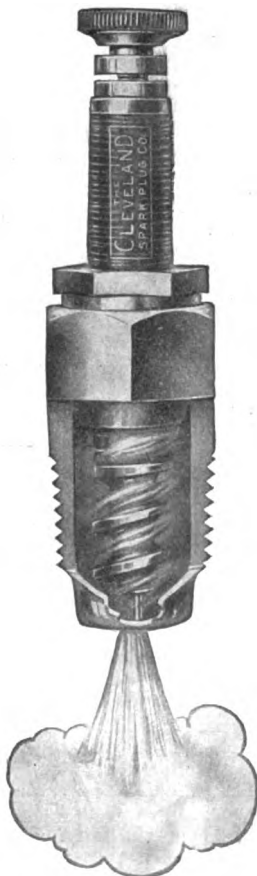

SECTIONAL VIEW CLEVELAND PLUG.

**The Giant Warner Auto-Meter's Travels.**—Last year, the giant Warner Auto-Meter traveled from Vermont to Washington, D. C., and in so doing covered more than 10,000 miles. It is now at the factory of the Warner Instrument Company, Beloit, Wis., being overhauled for its 1908 jaunt. It was a favorite stunt of the driver of the Stoddard-Dayton carrying the huge instrument, Jason de Silve, to drive through the streets of a city at its legal rate of speed, 8 or 10 miles an hour, and in every case he effectually succeeded in completely impeding all other traffic, so that the big instrument has brought home to many people how absurd their speed laws really are. With its aid, de Silve proved to the satisfaction of many local authorities that every moving vehicle on

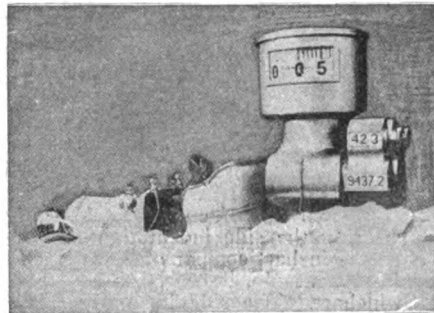

GIANT AUTO-METER IN THE SNOW.

the streets violated the law. The town of Pittsfield, Mass., was one of the first to change its speed regulation as the result of the eye-opening testimony of the big Auto-Meter. The huge instrument stands 9 feet 6 inches, weighs 800 pounds, and is exactly 1,000 times larger than the instrument used on a car.

**Keystone Grease for Autos.**—Having achieved an unapproachable reputation in the steam engineering field, the Keystone Lubricating Company, Twentieth street and Alleghany avenue, Philadelphia, has decided to enter the automobile trade and will sell direct to the garages and consumers on a fixed price scale. It is only necessary to consider the enviable record that this lubricant has made for itself wherever employed to realize that it will be but a short time before it achieves a similar measure of success in its application to automobile lubrication, which, in many respects, has not assumed the status of a definitely understood science, by any means. In large engineering establishments which conduct operations on a vast scale, and of which the William Cramp & Sons Shipbuilding Company may be cited as a notable example, the choice of a lubricant is not made haphazard, though this is usually the case where the selection of the material for this most essential factor in the maintenance of an automobile is concerned.

To be approved by such a firm, the lubricant submitted must pass a most rigid scrutiny on the part of chemists retained especially for this purpose, and unless it does so, it goes no further. If it is found to be entirely free from all deleterious substances, it is then submitted to equally searching efficiency tests in special machines and its qualifications for the service intended are searchingly gone into. To pass through such an examination successfully, a lubricant must be all that is claimed for it, and the fact that Keystone grease

has been adopted by a large number of such establishments speaks for itself. In the case of the Cramp company, it was not only found to meet all requirements, but proved more than 100 per cent. more economical than its nearest competitor, owing to the fact that it preserves its

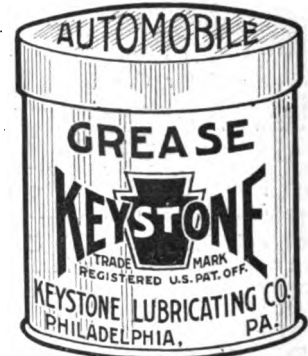

HOW KEYSTONE GREASE IS PACKED.

original consistency under all conditions and does not depend upon the temperature of the bearing for its lubricating properties. The Cramp tests showed its coefficient of friction to be .00340, as compared with a record of .00706 for its next best competitor. The Keystone Lubricant Company has now been manufacturing grease for more than a quarter of a century, and its plant at Philadelphia has a daily capacity of 20,000 pounds of lubricant, so that its introduction into the automobile field was bound to come sooner or later. The grades especially adapted for automobile lubrication are known as "No. 1 Density," a solid lubricant intended for use in automatic spring compression cups on axles, water pumps and other small bearings requiring a solid grease, and "No. 3 Density," which is semi-solid, and is intended for gear boxes and differential cases.

**Chase-Shawmut Portable Lamp.**—"A small amount of light properly directed is much more serviceable and incidentally more economical than a great deal of light uniformly distributed," say the makers of a new portable electric light for automobile use, the Chase-Shawmut Company, Newburyport, Mass. This new battery



PORTABLE ELECTRIC FOR TROUBLE HUNTING.

lamp is small, convenient and very neat in appearance. The lamp will pass through a 1/3-8-inch hole and is so designed that the light is thrown on the work, and not into the eyes of the holder. The bulb is so completely protected by the tubular reflector that the lamp can be stored in any convenient place. Looking for gasoline troubles with such a light becomes a pleasure, rather than a menace.



# THE AUTOMOBILE

## THE BRIARCLIFF TROPHY

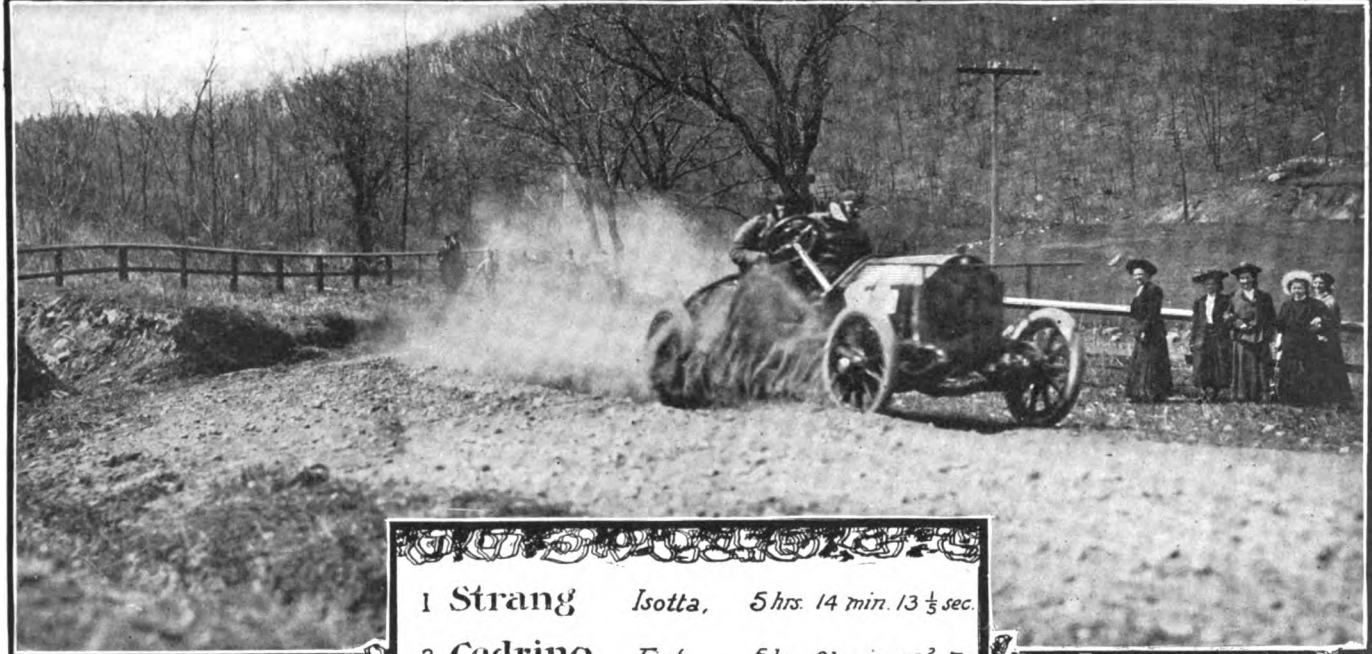

1	Strang	Isotta,	5 hrs. 14 min. 13 $\frac{1}{2}$ sec.
2	Cedrina	Fiat,	5 hrs. 21 min. 05 $\frac{2}{3}$ sec.
3	Vaughan	Stearns,	5 hrs. 28 min. 29 $\frac{2}{3}$ sec.
4	Lytle	Apperson,	5 hrs. 39 min 15 $\frac{2}{3}$ sec.

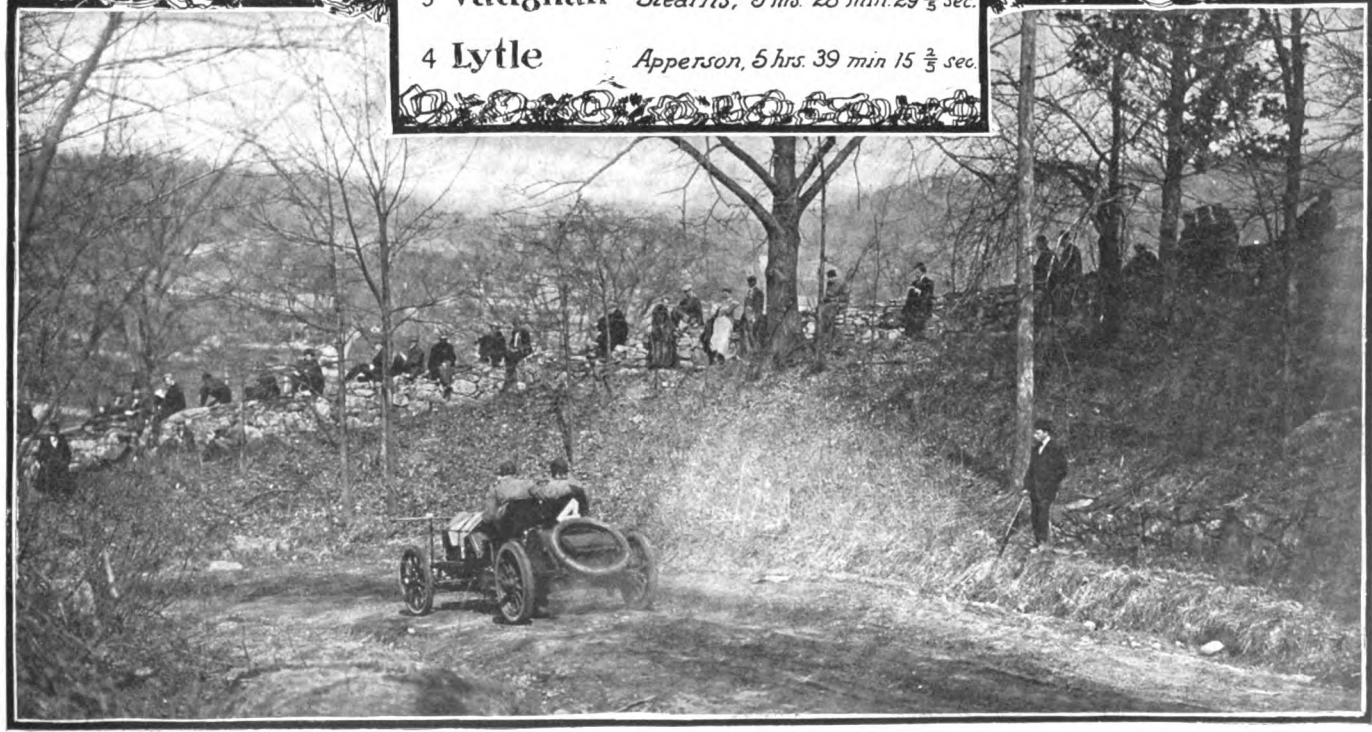

Strang Taking a Turn Without Hesitation, and Cautiously Descending a Corkscrew Grade.



# BRIARCLIFF WAS HARD-FOUGHT AND SPECTACULAR

By A. G. BATCHELDER.

**B**RJARCLIFF unquestionably demonstrated the roadability of those automobiles which participated. And true roadability demands much when it must be proven in such an event as the contest for the Briarcliff trophy, held over the picturesquely tortuous highways of Westchester county, N. Y., Friday, April 24.

So closely did the leading half-dozen mechanical contenders finish that the finding of the winner resolved itself into a question of personal equation. Strang, an ebullient and typical type of Americanism, born in Amsterdam, New York State, snatched the high honors by guiding a semi-racing product, imported from Milan, Italy. This car possesses a name pleasingly remindful of the land of art and olives and spaghetti, and it is a double-header: Isotta-Fraschini. Sturdy Strang had won with it at Savannah some few weeks previous, and his confident yet skilful piloting of the crimson-hued craft had caused his being picked by the wisecracs as the most probable winner of the twenty-two Briarcliff candidates. It is now a matter of history that he upheld this good opinion of his admirers, and in the success scored he deserves equal credit with the specially constructed car which he drove.

Cedrino, with another special made semi-racing car, was expectedly a most determined opponent, and it may be that he would have gotten closer to the leader if the race had been prolonged to the original ten circuits. But it is a pretty good guess that if Strang had been forced to do so, he could have gotten a sufficient amount of speed out of his smooth running Isotta to have retained the advantage.

As an actual matter of fact a large sized wreath of the laurels belongs to Guy Vaughan and the Stearns stock car which he drove. Engine troubles were nil, but tire experiences were unfortunate. And in this matter of tires, an element of luck was bound to exist over such winding, racking stretches of good, bad, and indifferent roads. Of the tire difficulties not a few could be traced directly to the inconsiderate manner in which drivers savagely went at some of the most abrupt turns.

Fourth to finish was "Herb" Lytle, whose consistency kept him among the quartette of leaders in every lap except one. Had it not been for an exasperating final run, he might have occupied third place. But one might also say that if Vaughan had not had his misfortunes, he might have actually won.

Unofficially fifth place belongs to Seymour and his Simplex, and likewise, unofficially, sixth place can be fairly claimed by Leland and a Stearns. Officially Sartori and the Bianchi get the honor, for it was after the clockers of "Sammy" Butler had suspended operations that Seymour and Leland forced their way through the straggling mob which had taken possession of the course immediately after the Bianchi had finished.



Guy Vaughan, Driving Stearns, Finishing Third.

While it is true that Nature supplied a course rather easy to police, it is a surmise that Providence must have lent aid to the volunteer soldier boys, who were more youthful looking than impressive without their uniforms and guns. There certainly was much for congratulation in the fact that the onlookers repeatedly displayed sufficient agility to keep out of the path of the flying cars, for in many instances it was more owing to their own activity than to the farcical authority of the cane-carrying soldiers that nothing serious happened.

The decision of William K. Vanderbilt, Jr., that no race for his trophy shall take place except over a properly guarded course—which means the presence of uniformed men armed with authority—still remains a logical and sensible decision.

Despite some daily newspaper reports to the contrary, it is a certainty that not half as many people saw the Briarcliff race as witnessed the 1906 struggle for the Vanderbilt cup. Had the very inadequate railroad facilities of reaching Westchester County been equal to the capacity of the Long Island transportation channels, thousands more would have journeyed to the Briarcliff event and would have added to the perils of the racers as well as to themselves. Therefore, it was most fortunate under the circumstances that the course was far less accessible than the one in Nassau county.

But the next race for stock chassis should have rules far more carefully drawn than those which governed the Briarcliff event. The manufacturer who enters such a contest should decline to do so unless confident that he will be fully protected from competing against cars of special construction, made in limited quantities, and in reality deserving the designation of racers.

Herewith are extracts from 1908 A. A. A. racing rules, drafted by a sub-committee, including S. A. Miles, Alfred Reeves, and A. L. Riker:

**"Stock Car."**—A motor car completely described in the manufacturer's catalogue for the current or any preceding year, which is manufactured in quantities, of ten or more, which is on sale by the regular selling representatives of the manufacturer and is manufactured ready for delivery to buyers.

**"Stock Chassis."**—A chassis which, without any change whatsoever, except that lighter gear springs may be used, can, by adding the necessary parts, be assembled into a complete stock car for which it is designed.

It is furthermore known that the technical board of the A. A. A. is going to add a few recommendations which may help to some degree in making stock car events exactly what they are intended to be: demonstrations to buyers of cars which can be bought at any time. It might be a good idea for the technical committee of the next stock chassis race to visit the factories of the entrants and in the assembling room pick out and stamp an entire car or its essential parts. This would make unfair advantages impossible and eleventh-hour protests unnecessary.

It should be said, however, that the Briarcliff race, in spite of its defects, would have been worth while if it had only demonstrated—as it did—the roadability of the average modern automobile. Such a vigorous examination could not have been accomplished scarce a year or so ago, and the searcher for mechanical fitness can find much to please him in a study of the Briarcliff summary.

Invading a county which was presumably desirous of giving a course for the race, Chairman R. L. Morrell and Secretary T. F. Moore and the committeemen encountered much opposition, which even prolonged itself until the midnight before the morning of the race. But difficulty after difficulty was smoothed out, hold-up after hold-up was met, and finally the road in front of the grand and official stands was sufficiently clear to enable the energetic Wagner to get the flying procession under way.

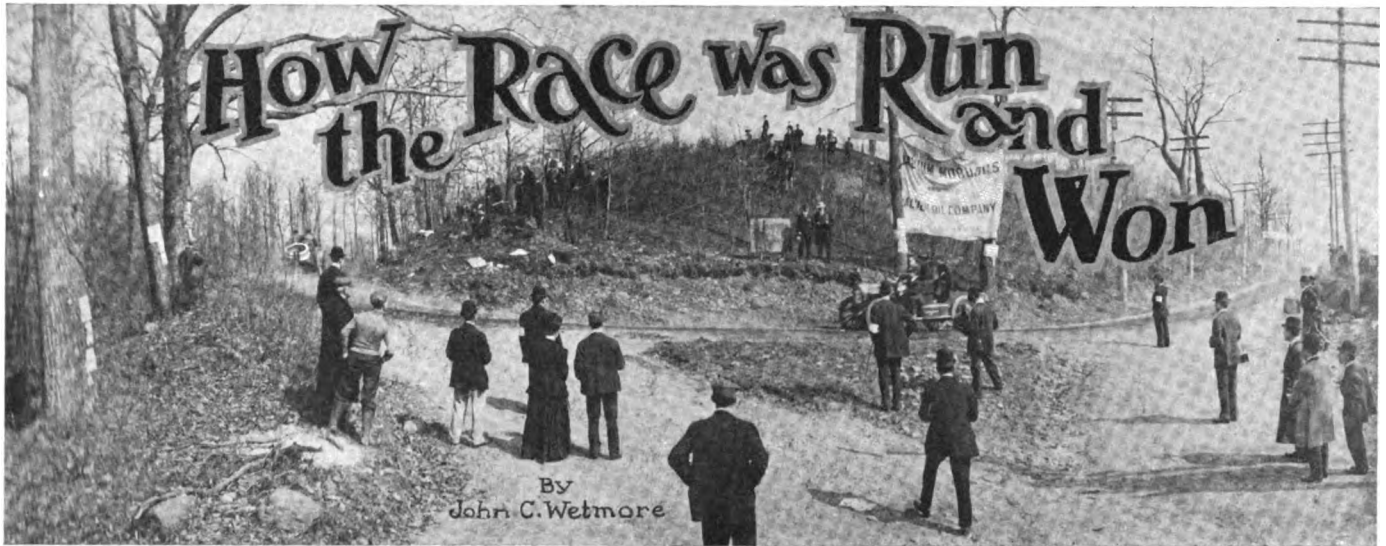

By  
John C. Wetmore

IT was not until 4:16 A. M. that Chairman Robert Lee Morrell and Secretary Thomas Francis Moore arrived at the grandstand. With the hour of the start—4:45 A. M.—less than a half an hour away, an appalling problem faced the promoters. Despite the fact that it had been announced that the course would be closed at not later than 3 o'clock, the home stretch was packed with scores of cars, whose occupants were begging to be told how to get to the official grandstand and the parking spaces. The roadway was a mass of pushing, jostling people. Newspaper men were calling for "Schwartz," and blindly seeking their allotted seats. Telephone men were adjusting wires and setting up transmitters, and telegraph linemen were connecting instruments. On the grandstand, located on the hillside above, ushers with lanterns were helping early comers in their search for boxes and seats. Bands of boisterous militiamarshals were pushing their way through the crowd to their stations, yelling with delight at this new lark of race-course guarding.

Sartori, who was to be the first starter, arrived at 4:22 o'clock and pushed his way to a place near the tape. Other contestants were behind him, but swallowed up in the human maelstrom that surged through the narrow home stretch. That the start could not be made on time was certain. Whether the race could be started at all was a problem. Starter Wagner plunged into the crowd, and began at once his task of getting the cars in line. He has hustled before. He never hustled and fought as he did this time. He was doing his work all right, all right.

With the time of the start but ten minutes away, the course was a mass of seething humanity. Talk of calling off the race entirely came from the group of naturally despairing officials. Something had to be done. Harry Burchall, chief of the marshals, proceeded to do it. Calling upon his aids, and appealing to a group of veterans for assistance, the struggle to clear the course began. With rushes marked by frequent hand-to-hand fights, the crowd was forced back and to the side until a semblance of a pathway was made, through which the cars might reach the starting line.

A. R. Pardington, the referee, announced to the press that the distance had been cut to eight laps, and that there would be a ten-minute control through Mt. Kisco for a stretch of 2.8 miles. No official measurement of the course was given out. Odometer reports had placed the length of the circuit between 32 and 33 miles, so by common consent 30 miles of racing road was accepted by all hands and the elapsed times announced were net on this basis. In a word, the eight 2.8 miles controls were eliminated in the timing. Each car was equipped with a box into which the control cards were dropped, following the method employed at the controls in the first Vanderbilt Cup race. Oldfield, by the way, lost his card-box during the progress of the race. McMurtry saved the cards.

At 6 o'clock the roadway was at least passable, though by no means clear. The official grandstand with its 3,500 seats and 240 boxes was a little more than half filled. The bank beneath the grandstand was crowded, shutting off the view of the finish stretch from the grandstand. In fact, the grandstand folks had but a meager peep for their money. A quarter of a mile below the course curved sharply and was followed by a hundred-yards climb up quite a perceptible grade. Then the racers almost immediately disappeared over the top of a hill beyond the start. The conditions at the stand were bad, and apparently nothing was known of how matters stood at other parts of the course. It was a gamble with fate, yet it was decided to cast the die, though "Wag" protested vigorously against the risk of a send-off being yet taken. At this moment two ambulances ominously drove up and took their stand by the roadside.

#### The First Lap.

The race was started at 5:07 o'clock, "Wag" counting Sartori away first and despatching the others at one minute intervals. All the drivers had friends to cheer them, but Barney Oldfield proved the prime favorite with the general public, though the fraternity seemed to take the most interest in Strang, Cedrino, and Vaughan. Bergdoll toed the scratch with no tool box, but on showing that he carried a full equipment of tools was allowed to start.

The first bulletin that Peter Prunty bawled through his megaphone was that Oldfield had passed Roberts, at the railroad crossing. Roberts had started just a place ahead of Oldfield. There had been considerable side betting between the followers of the two, so this information was interesting. Vaughan got by Michener at Armonk, and Cedrino passed Sartori at Val-



Oldfield (Stearns) Overhauling Harding (Isotta).



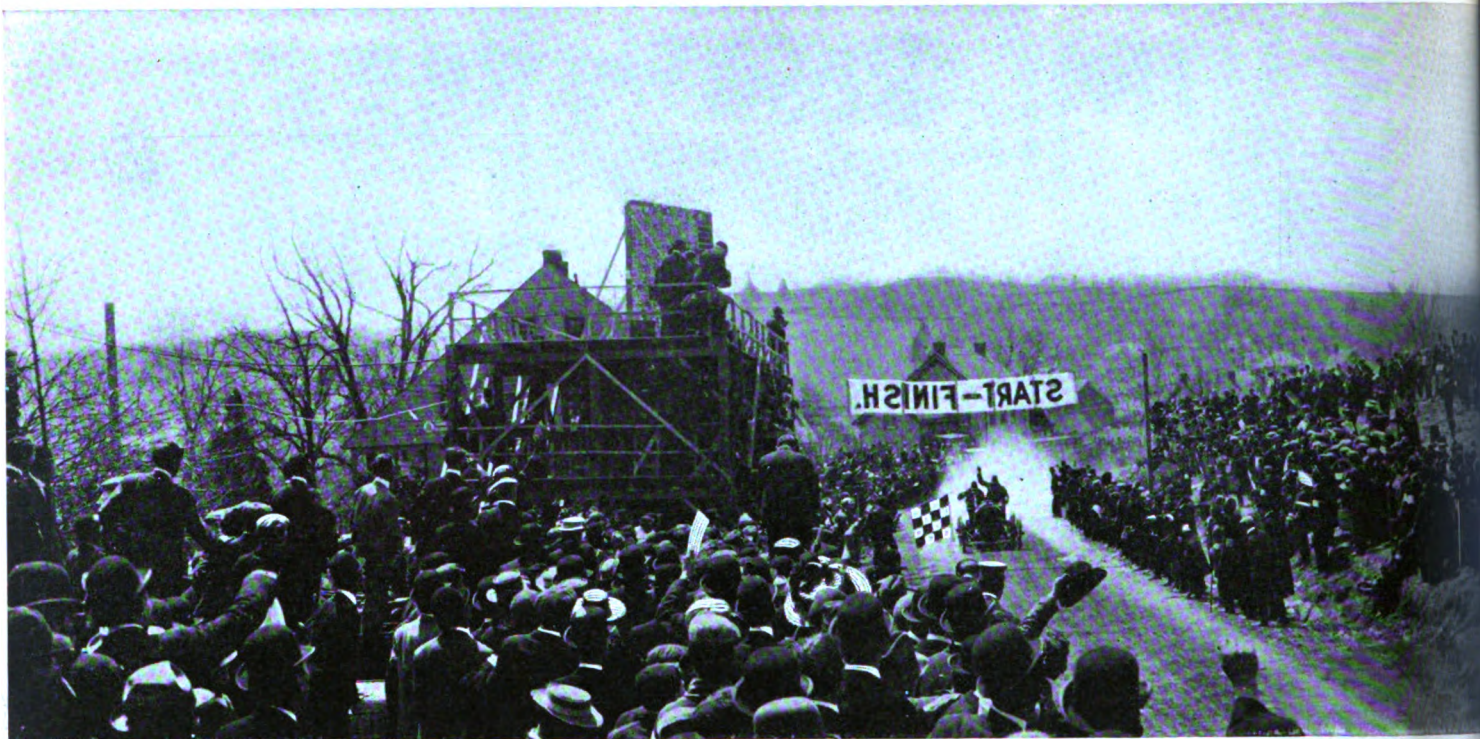

Happy and Victorious Strang, Driving the Winning Isotta Across the Finish Line.

halla, and led the procession. About this time the crash of an axe against wood behind the stand attracted attention. The Pinkertons were raiding the shell game camp that the nimble fingered gentry had pitched.

All this time Wagner, Burchall, and the whole outfit were fighting with the crowd to clear the course for the return of the racers. The megaphone bulletins had told that the leaders were nearing the stand, apparently well bunched. All eyes were directed toward the sharp turn at the foot of the hill. In a minute a red car dashed around it and up the hill. This was at 5:49:42 or 42:42 from the start. It was the Savannah cup winner, Strang. In a single lap he had got by Lytle, passed Cedrino, and disposed of Sartori, making the round in 39:42. In 18 seconds Lytle shot by in second place. Just behind him came Sartori. The latter's Bianchi was plunging from side to side and stopped at the foot of the hill with a punctured tire. Cedrino and Leland completed the lap in order before Sartori had replaced his tire and got under way again.

Strang was out for a runaway race of it, such as had brought him victory at Savannah. Seymour had made a splendid run from the start with the Simplex and was actually second and but 14 seconds behind Strang. He had fought his way from

twenty-first in line at the start to the fourteenth place in the procession. Lytle was third in the race, and Poole fourth. Harding, the third Isotta man, had put on two new tires and replaced spark plugs, and yet had managed to climb from nineteenth to tenth place in the race.

The first and most serious accident in the race occurred in the first lap. Watson, by reckless driving, dashed into a telegraph pole at East View. He and his mechanic, Cotter, were thrown out, but only slightly injured. Watson pluckily set to work to mend the bent steering post and wheel, and in less than three hours had his car running again, so that he was timed for five laps in all.

Michener came to grief just where Sartori did, and lost 4 1-2 minutes putting on a tire at the foot of the home stretch hill. Harding in this lap made a three-minute tire replacement in front of the stand.

#### The Second Lap.

The order of the four leaders in passing the stand on the second lap was little changed: Strang, Lytle, Cedrino, and Leland. Cedrino actually had been passed by Vaughan and Murphy. The latter, by the way, was making a remarkably good race with the little Maja, the lowest-powered car in the race. In actual time, Strang led Seymour by about two minutes, with Vaughan third and Lytle fourth. Strang was rapidly pulling away from his pursuers, a trio of American cars. The home product was showing up splendidly against the foreign cars. Strang had covered the second lap in 39:18 net, his fastest in the race.

Word now came that the planks on the bridge across Murray's Creek were loose and dangerous. A carpenter was hurried to the spot with new beams.

Another interesting bulletin was to the effect that a cable from the London surety company had been received stating that the protesting Greenburg, which threatened to stop the race, had been included in the indemnity bond.

Robertson, from whom much had been expected with the mighty Panhard, had had tire troubles to burn and had fallen far toward the rear. "Monty" Roberts, too, was greatly disappointing his admirers. Oldfield, a sensation maker by profession, had a narrow escape from being wrecked by a train at



Start of Murphy, the Maja Candidate.



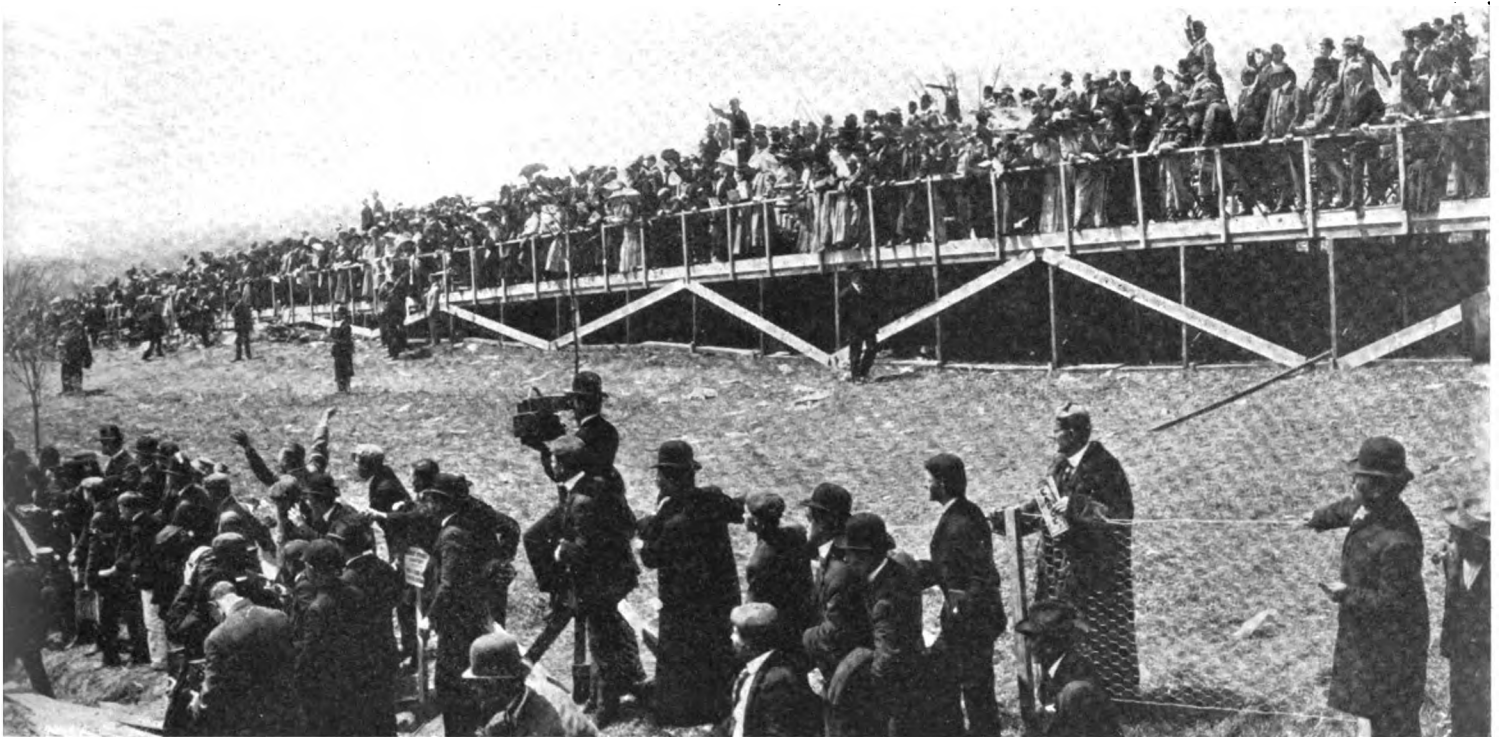

Picturesquely Situated, Unfortunately the Grandstand Did Not Supply a Most Extended View.

Kitchawan, the cow-catcher, so the story has it, actually lifting one of his rear wheels. Bernin's magneto came loose, and cost him a delay of 12 minutes before it could be readjusted.

**The Third Lap.**

Strang continued his daring runaway tactics and gained still another minute on Seymour in the third round. Vaughan and Lytle were having a hammer and tongs duel of it, and at this point the Stearns driver had a bit the better of the Jackrabbit. Minute intervals separated Seymour, Vaughan, and Lytle. Poole, who had a lot of troubles in the second lap with his spark plugs, just as he did at Savannah, got under way again with a vengeance and fought his way from tenth to seventh place. Oldfield was also going well with a lap in 41:15. In fact, the track champion was proving himself not a half bad road driver. Murphy was delayed by a blowout.

**The Fourth Lap.**

Seymour dropped back from his place as runnerup to lead in the next lap, letting Lytle and Vaughan into second and third positions respectively. The Simplex crack had been detained 13 minutes at Mt. Kisco, owing to the grease cup on his clutch having run dry. Strang, the leader, opened a gap of ten minutes on Vaughan, his nearest pursuer. The new American premier was going at wholesome speed, each of the four laps having been done under 40 minutes, a feat approached so far by but one of his rivals, Seymour, and that in only one lap. Barring accidents thus early he looked like an easy winner.

In this lap two cars were eliminated from the contest. Murphy, who had been making a fine showing with the Maja, having been at one time in fourth place, ditched his car and put it out of the running with a broken front wheel. Parker's Fiat ceased from strife with a cracked cylinder and a broken rocker arm.

This was the fastest lap for several of the racers: Harding, 41:48; Michener, 42:13, and Bloch, 45:29.

Oldfield's gas feed became clogged and his motor stopped. He had lost all his tools and was practically helpless. Finally the gasoline filtered through, the obstacle having been forced out. His loss of time at this juncture was very unfortunate.

**The Fifth Lap.**

Cedrino, the Cyclone pilot, now woke up and began the fast and well sustained run which finally landed him in second

place. The close of the fourth round had left the betting favorite in the race in fifth place. Having stopped to replenish fuel, he was prepared for a great effort. He certainly did make it, and make good with it, too, for he covered the 30-mile circuit in 39:35 and got by Poole, who had led him a couple of miles the preceding lap. He was now right on the heels of Lytle and Vaughan. The uncatchable Strang, however, was 12 minutes ahead of Lytle, his nearest pursuer.

Two more contestants went to the bad for good in this round. De Palma ditched the Allen-Kingston and hopelessly bent the front axle. Michener collided with a rock and bent the axle of the Lozier. In cranking the engine, it kicked and hurt his leg. This left 18 cars in the race fit for service and they all were running when the yellow flags stopped the race.

Mulford's mechanic in cranking the engine was actually kicked over and lay in the road senseless for some minutes.

**The Sixth Lap.**

A desperate hair-raising race was now on between Cedrino and Vaughan. In the duel between the two, Lytle was left behind and Strang's lead was considerably cut. The Italian put up a lap in 37:29. The blond New Yorker responded with a circuit in 36:51 and retained his second place by the narrow



Barney Oldfield, His Cigar, and Stearns Car.



margin of 15 seconds. Strang had slowed down to 40:24, yet still had over 11 minutes margin in case of accidents. Lytle, Poole, and Seymour were fourth, fifth, and sixth at one minute intervals. Sixteen minutes separated the first and sixth men of the leading sextette.

#### The Seventh Lap.

Strang without doubt now had the race well in hand, but not so surely that he could let up from the fast gait he had set and maintained from the start. Behind him Cedrino was driving like a wild man and eating up the intervening space with every bound. Faster and faster flew the Fiat. It had gone very fast in the fifth round, faster still in the sixth, and in the seventh there was still another kink of speed for Cedrino to let out. It was one of the most remarkable pursuits and gamest stern chases in the whole history of automobile racing. The Italian scored 37:16 for the seventh round, an average of about 48 miles an hour, a marvelous gait over such a course. He cut

The crowd was now uncontrollable and swarmed the course. Though it had been announced at the close of the seventh lap that eight cars would be permitted to finish, Chairman Morrell, seeing danger imminent, told the telephone men to 'phone for the hanging out of the yellow flags. Despite the crowd on the course Seymour managed to cross the line with the Simplex within three or four minutes, closely followed by Leland. Had they been officially timed, both would have beaten Sartori, who would have been thus put back into seventh place, as it started twenty minutes ahead of the Simplex and four minutes before the Stearns.

The final round brought quite a harvest of mishaps to the racers. Lytle had a blowout and two spark plugs blew out, all within four miles. Vaughan and Leland both had blowouts, the former one and the latter two. Seymour broke the hose connection to his radiator and was also held up five minutes by a train between the Apperson and Simplex camps. Leland ran out of gasoline, borrowed some from a Winton touring car

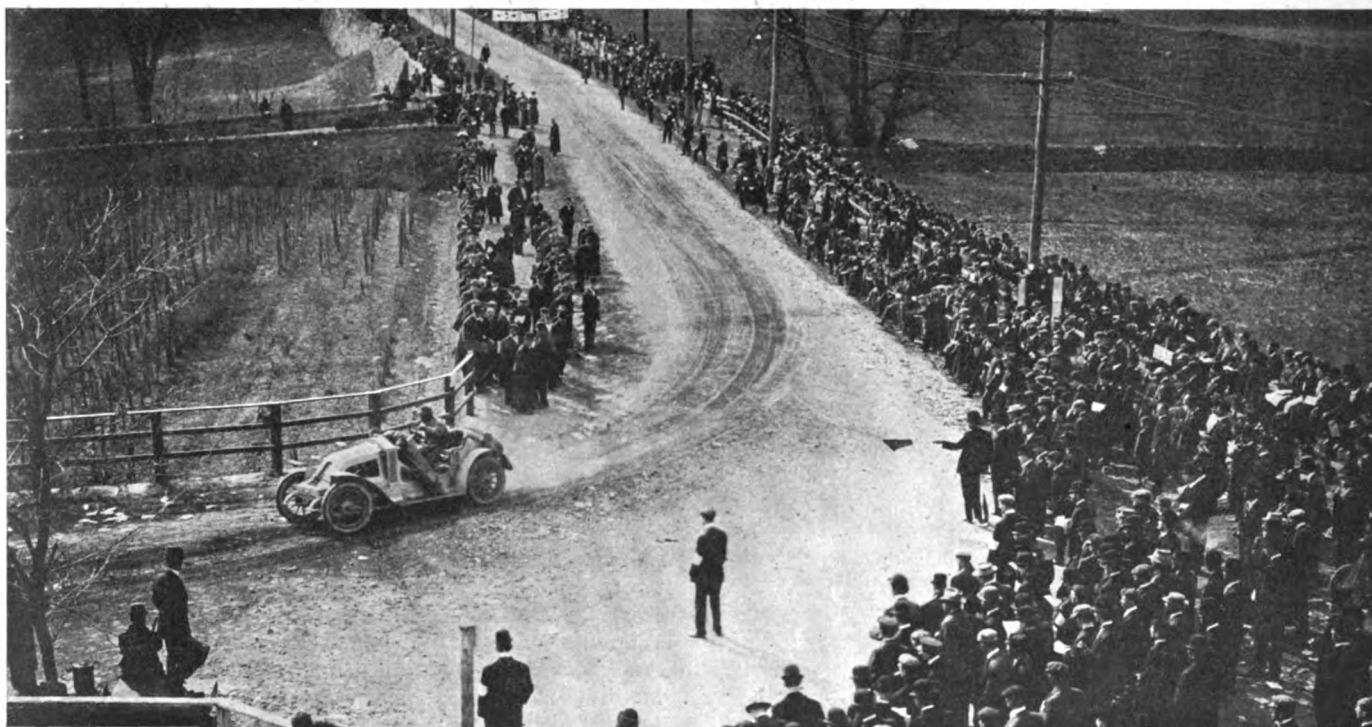

Renault, Bloch Driving, Enjoying One of the Best Stretches of the Entire Course, Where the Highest Speed Was Possible.

down Strang's lead from 11 to 10 minutes, though the Isotta crack had been going some himself with a lap in 38:43. Vaughan, Lytle, and Seymour were at Cedrino's heels as long distance racing goes and having a glorious triangular duel among themselves, Vaughan a minute and a half, Lytle three minutes, and Seymour six minutes behind the Italian, intervals that might easily be altered by a spurt or a slight accident.

Michener lost a tire. This made three punctures in all, each one occurring when he was far from any tire control.

#### The Finish.

The megaphone bulletins of the passing of the cars at the various points now became intensely interesting, and, in fact, vital. Reports from Mt. Kisco, Armonk, and Valhalla, told of the passing of Strang and Cedrino in order. Then came the final word from East View and the homestretch had been reached. Five minutes of excited suspense, and the red Isotta swung around the last corner with a mighty skid and thundered up the hill to the finish line, winner of the race in 5 hrs. 14 min. 13 1-5 sec. Cedrino's Fiat was second in 5:21:05 3-5. Vaughan (Stearns) was third in 5:28:29 2-5. Lytle (Apperson) was fourth in 5:30:15 2-5. Sartori (Bianchi) was fifth in 5:53:45 3-5.

and put it into the tank with beer bottles. Michener was stopped by a puncture while on his seventh lap.

#### HOW WINNING DRIVERS WERE REWARDED.

There is always a vast deal of glory for both car and man in crossing the tape victorious in a big automobile road race, but this is not the most substantial reward that the drivers of the first cars receive by any means. For instance, Strang received a bonus of \$1,000 from his employer, J. H. Tyson, \$500 from the Michelin Tire Company, \$100 from the Hess-Bright Manufacturing Company, and \$100 from Lavalette & Company, his winning Isotta having been equipped with Michelin tires, Hess-Bright ball-bearings and the Eisemann magneto. Another prize, previously announced as \$100, was raised to \$200, by the Hartford Suspension Company, the winning car having been equipped with its shock absorbers.

Cedrino, having taken second honors, received a prize of \$250 for bringing Continental tires over the tape in the next to best place, while Vaughan, in the Stearns, received a prize of \$125 for having gained third. In addition to the \$500 given to Strang for having brought Michelin's in first, the Michelin Company also gave \$500 to the entrants of the car, the Isotta company.



ACCORDING to A. L. A. M. rating, Strang's Isotta was the highest powered machine on the course, its cylinder diameter of 145 mm. being equivalent to 5.7087 inches, which by the formula gives 55.1 horsepower. Cedrino's Fiat that carried off second honors was much lower powered, showing but 48.4 horsepower; Vaughan's Stearns is rated at 46.2; Lytle's Apperson ties with the Fiat at 48.2; Seymour's Simplex, the non-official fifth, with its 53-4-inch bore, gives 52.9 horsepower; Leland with his Stearns, the non-official sixth, is 46.2, the same as Vaughan's; and Sartori's Bianchi, the non-official seventh, but official fifth, is but 41.6, the cylinder bore measuring 130 mm., which translates to 5.1182 inches. These were the only seven cars to reach the grand stand on the eighth lap and have their times recorded, the Simplex and Leland's Stearns being vouched for by three press representatives. Leaving the human factor out of the race then, the proper car won, assuming the mechanical construction of all of them to be on a par, which, of course, is far from the actual status of these seven machines.

That the highest-powered car should win, was not unexpected in the Briarcliff, due to the intoxicating meandering of the course through mountain valleys, by woodland stream, through forests, and by lakes, providing, of course, the car was geared for the test. Here is where some of the makers—and they were not a few—made a grave error; speed was the sole object sought, and, of course, high gearing was looked upon to provide this. But in this calculation the problem of having to slow down 87 times on each circuit because of bridges, corners, curves, or railroad crossing, besides added lowering of speed due to other cars on the course, was neglected, and this alone was responsible for a part of the story. Approximately 90 slow-downs on each circuit makes 720 on the eight laps, and whenever there was a slow-down there had to be a picking-up, and in these 720 pick-ups the mediumly geared cars had a great advantage. This was particularly noticeable at some of the grandstand curves. Once on the short straightaway stretch leading past the grandstand, Strang would throw into high and be away in a twinkling, whereas not a few of the others were slow and lost time on changing gears. In a course with 50 per cent. of straightaway, high gearing is good, but not so where 720 curves or turns have to be made. This happy combination of high power and medium gearing, coupled with the dexterity of Strang as a racing car pilot, and the good construction and design of the Isotta was the cause of the victory.

**Wheelbase.**—Next of importance in racing cars over a course of Briarcliff nature is the abbreviated wheelbase, which was lacking on most of the twenty-two competing cars, the Apperson, Hol-Tan, Shawmut, and Fiat being the only ones between the 100 and 110-inch marks. Strang drove a 118-inch machine, Vaughan's Stearns is 120 inches, the Loziers are reported at 124 inches, the two Simplexes have the same measurement, the Bianchi is 120, and the two Renaults and the Thomas are catalogued at 112 inches. The exact length of the Fiat wheelbase

is not known, but it is short, and this was in part responsible for a few of the fast laps Cedrino made. In making the grandstand curve Strang never accomplished it nearly so fast as Cedrino did on his last four laps; Lytle took it fast without apparent skidding; whereas Seymour with his long wheelbase Simplex threw up more dirt at less speed. Poole in his Isotta is a fast corner driver, duplicating not a few of his performances of the Savannah course, but throwing up clouds of loose earth on the poorer turns.

But the abbreviated wheelbase did not play as big a part on the 600 or more turns each driver who completed the eight laps had to make as might be expected, due to the peculiar grouping of the turns, it being rare except at right-angled turns for one to be alone. In places three or four follow in succession, the driver having to zigzag the course for a half mile at a stretch. On such places fast speed is not possible with any length of wheelbase; but it would have been interesting if a car of 96-inch wheelbase, much like the winning Darracq in the last Vanderbilt race, had been in the contest.

**Tires.**—After having noted a few of the primary considerations on racing cars, the majority of the spectators, for some unknown reason, look into the tire situation, and not a few of them believing that tire size, as well as construction, is a determining factor in a contest. With the exception of the Renaults, all of the foreign machines used one size of tires on the front wheels and a larger size on rear; Strang's Isotta used 870 by 90 mm. or 34.25 by 3.54-inch ones on the front wheels and 880 by 120 mm. or 34.64 by 4.72-inch pneumatics on rear. Cedrino's Fiat used the same sizes. It is not known the exact sizes used on the Stearns machines; Lytle used 34 by 3 1-2 and 4-inch front and rear; Sartori was an apparent believer in big tires, his Bianchi carrying fronts measuring 35.82 by 3.54 inches and the rears 36.02 by 4.13 inches. But it remained for the Simplexes and the Panhard to take the biggest sizes, these cars using 36.8 by 5.31-inch ones on rear. The Simplex used a 36.02-inch size in front, but the Panhard preferred a smaller size. The Loziers used 36 by 4 and 4 1-2-inch sizes in front and rear; 34 by 4 and 4 1-2 sizes were carried by Roberts on his Thomas; the Shawmut carried 3 and 36-inch makes; and the Allen-Kingston and Maja used small sizes. Practically all of the cars started off with studded-treaded pneumatics on the rear wheels and plain treads on the fronts; but it was noticeable how many put the studded treads on the fronts when a change was necessary.

It rarely happens in a race in this country that grandstand spectators have a glimpse of tire repair work, but two good views were had of this right at the starting and finishing points. On his first lap Sartori blew out on the grandstand turn, and a little later Poole changed at the same point. Both were good examples of the value of the demountable rim, the time required in one case being less than three minutes and in the other a little over four minutes. That Strang should make the



A Change of Tires at the Continental Control.

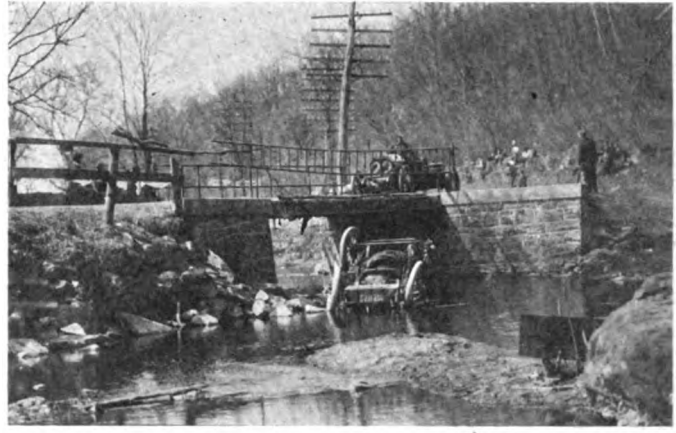

Where Ryall's Matheson Landed Two Days Before.



Barney Oldfield Tries a New Tire.



Pinkerton Man Putting a Gambler's Plant Out of Business.



Bloch (Renault) Approaching Grandstand.

240 miles without a change of Michelins, incidentally duplicating his Savannah performance, is a point of great interest, and seems to prove that it is not so much the taking of corners as continuous high-speed traveling that works havoc with tires. While there were times in the Briarcliff that the cars were touching 80 miles per hour or more, these periods were exceptionally brief, and the tire temperature was apparently kept lower because of this. Those drivers who had tire trouble had it because of too fast corner work, due to hitting the corner at too high speed, using the brake too severely and then skidding badly on the turn. Parts of the course were very hard on tires, due to the loose stones; but, offsetting these spots, was the 10-minute control in Mt. Kisco which gave the tires an excellent opportunity each lap for dropping a few degrees in temperature. The steel studded tire proved a good servant for the many turns, as well as the multitudinous braking work.

**Brakes.**—One entrant after the race declared that to-day it is harder to make a good brake than a good motor, and the worn condition of a few of the brakes proved the quantity of truth the assertion contains. The last few Glidden tours have impressed very emphatically on many makers the efficacy of ample braking surface; in fact, tours impress this more than road racing. But the Briarcliff was an ideal jousting ground for friction brakes. All of the chain-driven cars with the exception of the Panhard used four brakes, the preferred location being two contracting band ones on the jackshaft and two expanding or contracting members on the rear wheels. Strang employs the cast iron against steel variety having two located on the jackshaft and two on the rear wheels. On the Fiat four metal brakes are positioned, two on the transmission and two on the rear wheels; on the three Stearns cars are steel against brass brakes, two on the jackshaft, two on the driving wheels; on the Apperson are four on the back wheels, the expanding set steel against bronze; the four on the Simplex machine are two copper-lined ones on the differential shaft and two cast iron against steel rear wheel brakes. Many of the shaft-driven machines use but three brakes, two on the rear wheels and one on the drive shaft or transmission shaft. It was a commendable point to notice how little slipping of the wheels was done in making the turns, the old-time story of "slipping the wheels and skidding around the corner" not having many followers. Such "slipping and skidding" makes a few seconds only to be lost in minutes by changing tires.

**Ignition.**—In ignition the magneto has the entire field; the winning Isotta used an Eiscmann high-tension magneto such as is familiar to many American car owners; a similar machine was employed on the Panhard, and in practically all of the remaining twenty machines Bosch magnetos of the high or low-tension variety were used. Double sets of spark plugs are quite common, but even two sets were not sufficient for many of the machines, and plenty of spark plug trouble was experienced. With Poole the porcelains gave trouble, as they did in Savannah, and Lytle's last lap was 10 minutes longer than his previous



ones because of these little parts. A portion of the trouble seems to be not in the fouling of the points, but in the fusing of them, due to the amperage and voltage. Plugs removed were perfectly clean, but the two sparking points united by a metal bridge.

**Clutches.**—The majority of cars used the multiple disk clutch, the followers of cone clutches being limited to the two Renaults; the Apperson was the only band clutch; the Stearns the only expanding type; the Maja the only coil spring Mercedes type; the Thomas the only three-disk variety, and the rest including Isotta, Fiat, Bianchi, Simplex, Lozier, Allen-Kingston, Panhard, and Shawmut used the multiple disk variety, the number ranging from fifty-one bronze and steel disks in the Isottas to smaller numbers in some of the others. The Shawmut employed the well known Hele-Shaw type containing fifty-one disks each having corrugations to increase the friction surface without excessive diameter as well as to facilitate disengagement.

**Speeds.**—In change speed sets, the selective type is paramount, the Panhard being about the only adherent of the progressive variety. The three Isottas were the only cars having but three forward speeds; all of the others using four.

Car	H.P.	Bore	Stroke	Car	H.P.	Bore	Stroke
Isottas	55.1	5.7087	4.7245	Renault	44.1	5 1-4	5 3-4
Fiat	48.4	5.5110	5.1182	Thomas	52.9	5 3-4	5 1-2
Stearns	46.2	5 3-8	5 7-8	Allen-King'n	40	5	5 3-4
Appers'n	48.4	5 1-2	5	Panhard		5 45-64	5 5-16
Bianchi	41.6	5.1182	5.9056	Maja	30	4.3308	5.1182
Simplex	52.9	5 3-4	5 3-4	Shawm't	36.8	4.8	5 1-2
Lozier	44.1	5 1-4	5 1-4				

**Motors.**—Practically all of the motors excepting Apperson, Thomas, and Panhard, use cylinders cast in pairs, some employing valves on one side and others on opposite sides. The "T"-head cylinder is employed in the Apperson, Thomas, and Panhard. Where cylinders are in pairs the desire to obtain large valves has led to placing the valves oppositely, as in the case of the Isottas that employ 2 1-2-inch valves; but the Stearns cars have them on one side. Positive pump and fan circulation is in use on all excepting the Renaults, in which thermo syphon circulation is employed, and in which cars the radiators are carried at the rear of the motor, forming the dash.

**Lubrication.**—The trouble with the majority of motors on long races appears to be the lubrication problem, and it is surprising the amount of oil injected into them, especially those of the high-speed variety. Over 40 gallons were used on the 240 miles by three of the contestants, two of the others said over 30 was used by each of them, and those not questioned doubtless have similar tales of big oil consumption. When many of the cars passed they were lost in a cloud of smoke, which was such as to fill the road from side to side; on the other hand not a few cars made the seven or eight laps without ever emitting a bit of smoke, and it would be interesting if it were only known how much oil they used. As it is, the oil consumption of a car in a big race is not comparable to the consumption of such a car on touring work, and the prospective buyer need not get frightened at this favorable Standard Oil showing of some of the fastest machines.



This Was Headquarters for Maxwell Owners.



Cedrino (Fiat) Making a Turn.



Hilliard (Ho-Tan) at the Railroad Crossing.



Michener (Lozier) at Mt. Kisco Control.



Being Escorted Through Mt. Kisco Control.



Stock Cars?—As to stock cars, the less said in some cases the better. There were stock cars in the race, not a few of them, and they were immediately recognized by the spectators. But, on the other hand, there were cars of which ten duplicates have not been built as yet by the factories. There is not a doubt but that ten of the Isottas have been built and sold; in fact, there is good proof that many more than that number have left the factory; there is some doubt as to the manufacture of ten duplicates of Cedrino's Fiat, which proved to be the fastest

car on the course; the Appersons are known to have built more than ten of their "Jackrabbits"; questions have been raised as to whether ten of the Loziers were finished by the time limit set; but with the Stearns, Thomas, Allen-Kingston, Shawmut, Maja, Renault, Simplex, and Bianchi not a word was said. They are stock machines and look it.

The Mt. Kisco Control.—The ten minute control at Mt. Kisco puzzled a great many. Here the racers were met by men on motorcycles and escorted through the control at a regulated

TABULAR STORY OF 240-MILE RACE FOR BRIARCLIFF TROPHY, APRIL 24, 1908, IN WESTCHESTER COUNTY, N. Y.

No.	CAR	H.P.	Owner	Driver	1	2	3	4	5	6	7	8	Running Time
4	ISOTTA	50	J. H. Tyson	Strang	39:42	38:23	39:18	38:39	38:38	40:24	38:43	40:26	1-5 Sh., 14m., 13 1-5.
2	FIAT	60	Fiat Co.	Cedrino	45:01	40:03	40:09	44:44	39:35	37:29	37:16	36:48	3-5 Sh., 21m., 05 3-5.
8	STEARNS	60	W. C. & P.	Vaughan	42:12	40:15	39:43	43:56	41:50	38:51	38:52	42:50	2-5 Sh., 28m., 29 2-5.
3	APPERSON	50	S. B. Bowman	Lytle	41:00	40:47	42:01	43:11	40:36	40:36	39:25	51:39	2-5 Sh., 39m., 15 2-5.
1	BIANCHI	40	Percy Owen	Sartori	48:15	43:14	44:29	47:05	44:31	42 17	41:55	41:59	3-5 Sh., 53m., 45 3-5.
21	SIMPLEX	50	Palmer & Singer	Seymour	39:56	40:31	40:05	51:48	39:56	39:16	39:28	Still running	
5	STEARNS	60	W. C. & P.	Leland	43:16	42:01	41:24	49:49	39:14	45:06	40:13	Still running	
11	ISOTTA	50	Isotta Co.	Poole	41:03	44:54	41:03	40:59	41:51	39:49	54:41	Still running	
19	ISOTTA	50	Isotta Co.	Harding	43:54	51:31	43:14	41:48	47:09	42:46	43:41	Still running	
13	STEARNS	60	W. C. & P.	Oldfield	43:47	41:39	41:15	59:57	43:15	50:46	46:59	Still running	
16	HOL-TAN	40	Hol-Tan Co.	Hilliard	46:00	46:04	45:41	45:55	47:48	46:39	50:07	Still running	
18	RENAULT	50	Paul Lacroix	Bloch	48:16	45:48	46:54	45:29	49:34	47:19	47:04	Still running	
12	THOMAS	50	Harry S. Houpt	Roberts	52:35	50:13	50:17	49:07	47:20	45:23	47:31	Still running	
14	RENAULT	50	Paul Lacroix	Bernin	59:38	102:48	152:05	201:72	249:32	294:55	342:26	Still running	
20	BENZ	50	L. J. Bergdoll	Bergdoll	52:02	45:18	44:38	52:20	44:27	45:20	44:30	Still running	
7	LOZIER	45	Lozier Co.	Michener	48:30	44:37	46:21	42:13	42:14	47:49	Still running		
15	PANHARD	50	Panhard Co.	Robertson	47:48	62:44	52:38	60:20	55:35	48:56	Still running		
22	SIMPLEX	50	Palmer & Singer	Watson	177:31*	110:32	162:70	223:30	279:05	328:01	Still running		
17	ALLEN-KINGSTON	30	W. C. Allen	De Palma	43:33	42:03	44:41	42:54	Ditched and bent front axle				
9	LOZIER	45	Lozier Co.	Mulford	44:17	85:36	130:07	173:01	Mechanic hurt				
10	MAJA	30	J. J. Brown	Murphy	41:31	40:56	44:49	.....	Front wheel collapsed.				
6	FIAT	60	Fiat Co.	Parker	44:09	72:12	127:16	40:31	.....	Cracked cylinder			

Note.—Although the officials announced just prior to the end of the race that eight cars would be allowed to finish, owing to the manner in which the spectators crowded on the course, the word for the yellow flag was given when only five had come in. Despite the people on the course, Seymour, in the Simplex, No. 21, crossed the line within three or four minutes, closely followed by Leland in the Stearns, No. 5, both thus beating the Bianchi, which should really be placed seventh, instead of fifth, as it started 20 minutes before the Simplex and 4 minutes before the Stearns.  
\*Overturned on first lap, putting steering gear out of commission.

HOW POSITIONS CHANGED DURING PROGRESS OF RACE.

No.	CAR	H.P.	Driver	1st	2nd	3rd	4th	5th	6th	7th	8th
4	ISOTTA	50	Louis Strang	1	1	1	1	1	1	1	1
2	FIAT	60	Em'n'l Cedrino	13	6	6	5	5	3	2	2
8	STEARNS	60	Guy Vaughan	7	4	3	4	2	3	3	3
2	APPERSON	50	H. Lytle	2	3	4	2	5	4	4	4
1	BIANCHI	50	P. Sartori	16	11	12	11	10	8	8	5
21	SIMPLEX	50	Seymour	3	2	2	6	6	6	5	5
5	STEARNS	60	Leland	6	7	7	8	7	7	6	6
11	ISOTTA	50	Al Poole	4	10	5	2	3	4	7	7
19	ISOTTA	50	Harding	10	16	14	9	11	9	9	9
7	LOZIER	45	Michener	18	14	15	10	8	10	10	10
13	STEARNS	60	B. Oldfield	9	8	7	14	9	11	11	11
16	HOL-TAN	40	Hilliard	14	12	13	12	12	12	12	12
18	RENAULT	50	J. Bloch	17	15	16	13	13	13	13	13
20	BENZ	50	L. J. Bergdoll	19	17	17	16	14	14	14	14
12	THOMAS	60	M. Roberts	20	18	18	17	15	15	15	15
14	RENAULT	50	M. Bernin	21	19	19	18	16	16	16	16
15	PANHARD	50	G. Robertson	15	20	20	19	17	17	17	17
22	SIMPLEX	50	Watson	22	22	22	20	18	*	*	*
17	ALLEN-KINGSTON	30	De Palma	8	9	10	7	Ditched			
9	LOZIER	50	Mulford	12	13	11	15	Mechanic hurt			
10	MAJA	30	Murphy	5	4	9	Broke front wheel				
6	FIAT	60	Parker	11	21	21	Cracked cylinder				

\*Running when race was called.

FASTEST LAPS AND MILES PER HOUR.

No.	CAR	Driver	Lap	Time	Miles Per Hour
4	ISOTTA	Strang	2nd	38:23	47:30
2	FIAT	Cedrino	8th	36:48 3-5	49:25
8	STEARNS	Vaughan	6th	38:51	46:75
3	APPERSON	Lytle	7th	39:25	45:54
1	BIANCHI	Sartori	7th	41:55	42:80
21	SIMPLEX	Seymour	6th	39:16	45:50
5	STEARNS	Leland	5th	39:14	45:45
11	ISOTTA	Poole	6th	39:49	45:05
19	ISOTTA	Harding	4th	41:48	43:50
13	STEARNS	Oldfield	3rd	41:15	41:80
16	HOL-TAN	Hilliard	3rd	45:41	39:56
18	RENAULT	Bloch	4th	45:29	39:65
12	THOMAS	Roberts	6th	45:23	39:56
14	RENAULT	Bernin	6th	46:39	38:71
20	BENZ	Bergdoll	7th	44:30	40:45
7	LOZIER	Michener	4th	42:13	41:60
15	PANHARD	Robertson	1st	47:48	37:60
22	SIMPLEX	Watson	3rd	40:07	45:00
17	ALLEN-KINGSTON	De Palma	2nd	42:03	42:85
9	LOZIER	Mulford	3rd	43:04	41:86
10	MAJA	Murphy	2nd	40:56	43:91
6	FIAT	Parker	3rd	40:31	44:44

speed of 20 miles per hour. Some complaint was made by the deputy sheriffs that a great many of the drivers exceeded this speed, in spite of the fact that no matter how fast they made the control they had to stay there for ten minutes. This was remedied, and the officials of the law were satisfied.

An Old-fashioned Lady.—One of the curiosities of the race was an old-fashioned lady who owned nearly an eighth of a mile of haying ground alongside the course, just below the grandstand. She refused all offers from speculators to rent her property for the day for a grandstand.

MILES PER HOUR FOR 240 MILES.

No.	CAR	Driver	Total Time	Miles Per Hour
4	ISOTTA	Louis Strang	5:14:13 1-5	46:15
2	FIAT	Emanuel Cedrino	5:21:05 3-5	44:44
8	STEARNS	Guy Vaughan	5:28:29 2-5	43:95
3	APPERSON	Herbert Lytle	5:39:15 2-5	42:24
1	BIANCHI	Paul Sartori	5:53:45 3-5	40:40
21	SIMPLEX	Joseph Seymour	5:38:05*	43:37*
5	STEARNS	F. W. Leland	5:42:00*	42:85*

†Eight laps of 30 miles each, deducting distance of control at Mt. Kisco.  
\*Figured on unofficial times, the Simplex and Stearns having finished four and eight minutes after the Bianchi in spite of the crowd that impeded their progress on the last third of their closing lap.



Bernin and Renault Passing Tire Control Where He Didn't Stop.

LITTLE things play a very large part in automobile road racing, and the omnipresent hand of Dame Fortune—luck for short—may make or mar the chances of any one of the aspirants a dozen times in a single round. What an all-powerful factor luck in little things is, where success in road racing is concerned, has been strikingly proven time and again on the smooth stretches of the Long Island course, with its magnificent straightaway stretches. How very much more so must it prove on the tortuous, 30-mile circuit of the crumpled-up paper type, with its impossible bends and turns, each one with its pitfall of narrow, creaky bridge, or its menacing stone wall, and with scarcely a quarter mile straight, or a half dozen places where a competitor could safely be passed at speed? This was the general consensus of opinion of the race-seasoned spectators and the devotees of the pencil and camera gathered at the stand at Briarcliff last Friday, patiently waiting for the time when the raucous barking of the hot frankfurter man would be drowned by the exhaust of the racing cars as they came to the line to be sent off to—who knows what? Conjectures were of every shade of pessimism.

Accustomed to seeing quite a substantial percentage of the competitors eliminated for once and all, before completing one lap of a good course, what would happen to the driver on this indescribable conglomeration of hills, twists and turns on which the slightest indiscretion meant disaster, was a matter of endless speculation. The little things counted, to be sure—they must always be reckoned with, but there were so few of them, and they were of such a commonplace nature in the main that precedent may be said to have been effectively overthrown. Never before have so many cars been running in full blast when the starter's checked flag has fallen over the last car to cross the line and the impatient spectators along the course have made further continuance of the race unsafe by crowding out into the road, as they did on Friday last in true Vanderbilt race style, once the

flag had dropped on the fifth car.

While the inevitable happened, in that most of the delays were due to tire trouble, and, as must always be the case, they formed the bulk of the causes that made for delay, still they were very far from amounting to what had naturally been anticipated of the course, or what was to have been expected in view of the terrific strains that it imposed. Vaughan, in the 60-horsepower Stearns, carrying "No. 8," which was the first American car to cross the line, might well have been moved up a place or two in the finishing order, had it not been for the loss of two tires. Study of his performance by laps shows that they cost him close to ten minutes, and as they formed a great source of delay, it is safe to say that Vaughan would have brought the Stearns over the tape in a much better position had it not been for their retarding influence. The rear left tire gave way near Wampus Lake on the third round, so that instead of bettering his time for

the lap by two minutes, as was the case on the second round, it took seven minutes more than the first time over course.

By the sixth round, Vaughan had been steadily making his pace better and had succeeded in getting well below the 50-minute mark. He passed the stand on the final going at a good pace, but had hardly cleared the brow of the hill above the grandstand when the front left tire blew out. Quick work was done in replacing this, the total loss being about four minutes, as shown by a comparison of the lap performances. Lytle's delay in the Apperson insured Vaughan third place, but without the delays incident to tire troubles, he would easily have made second, as is shown by the fact that Cedrino was but seven minutes ahead at the finish, in spite of the Italian's daredevil driving on the last three laps, which were the fastest of the race, all being under the 40-minute mark.

**How the Little Things Lost Places.**

It is certainly bad enough to have to reflect that nothing more than a mishap of the most trivial nature was responsible for



Bergdoll, the Benz Contestant, Rounding One of the Many Turns.

delay which brought lost honors in its train, but how very much more so is it when, after having completed all but a few miles of the distance, one of those petty little details that is not even considered an inconvenience at other times, crops up to spoil good chances of crossing the line among the first three. Such was the lot of Lytle in the Apperson. The little Apperson had been reeling off the miles like a watch—nothing phenomenal in the way of speed, but demonstrating by every lap that it was displaying in the most striking manner those very qualities which the race was designed to bring out. Lap after lap, it passed the stand with its times for the rounds but a few seconds apart, while the fifth and sixth laps were covered in identically the same time to a second, Lytle taking 40:36 in each case to cover the thirty miles, while the first and second laps were but 13 seconds apart.

Lytle started third and ran so regularly that the Apperson was generally believed to have third at the finish pretty heavily mortgaged, as the Apperson had a clear lead of several min-

utes over Vaughan's Stearns at the opening of the last lap. But the little things had not been reckoned with. Lytle's Diamond tires, which had borne up under the terrific strain without a sign of weakening up to the time, stood the racket until the last half of the last lap, when the right rear gave up the ghost between Armonk and Valhalla. The Apperson crew certainly had no cause for complaint on the score of tires, but what little trouble did fall to their lot came at a most inopportune moment.

But Lytle still had a comfortable hold on third, even after replacing the damaged tire, and would have had no difficulty in getting home in that position with a good margin if the same evil genius had not continued to pursue him. Immediately after replacing the tire the engine began to sputter and an examination showed that the ignition current from the magneto had been too hot for the points of a spark plug. The process had to be repeated twice, three plugs being replaced, in addition to the tire, all within three or four miles on the last lap.

It is not to be inferred that tires alone were the cause of some of the competitors, whose chances for places among the first five seemed excellent in the early part of the race, after falling behind. Seymour, whose driving of the 50-horsepower Simplex, carrying "No. 21," aroused great admiration, lost more than

enough time to prevent him from scoring well, through one of those petty little things that is all the more exasperating owing to its very simplicity. The grease cup on the clutch collar of the simplex ran dry and the clutch heated so that it could not be disengaged. This cost Seymour 13 minutes on the fourth lap. But even at that, he might still have scored had not further and equally simple and aggravating mishaps caused more time to be spent in fussing instead of covering the distance at the good clip which the Simplex maintained throughout the race. Nearing the latter half of the last lap, the piece of hosepipe connecting the radiator and the pipe on the motor loosened and let the water escape. This was quickly made good, but Seymour then found himself on the wrong side of a railroad train at the crossing about half way between the Apperson and Simplex camps. Trains moved so rapidly on race day that this little coincidence cost another five minutes—just enough to prevent coming in fifth—that is, officially, as in spite of these handicaps his running time taken unofficially entitled him to that position.

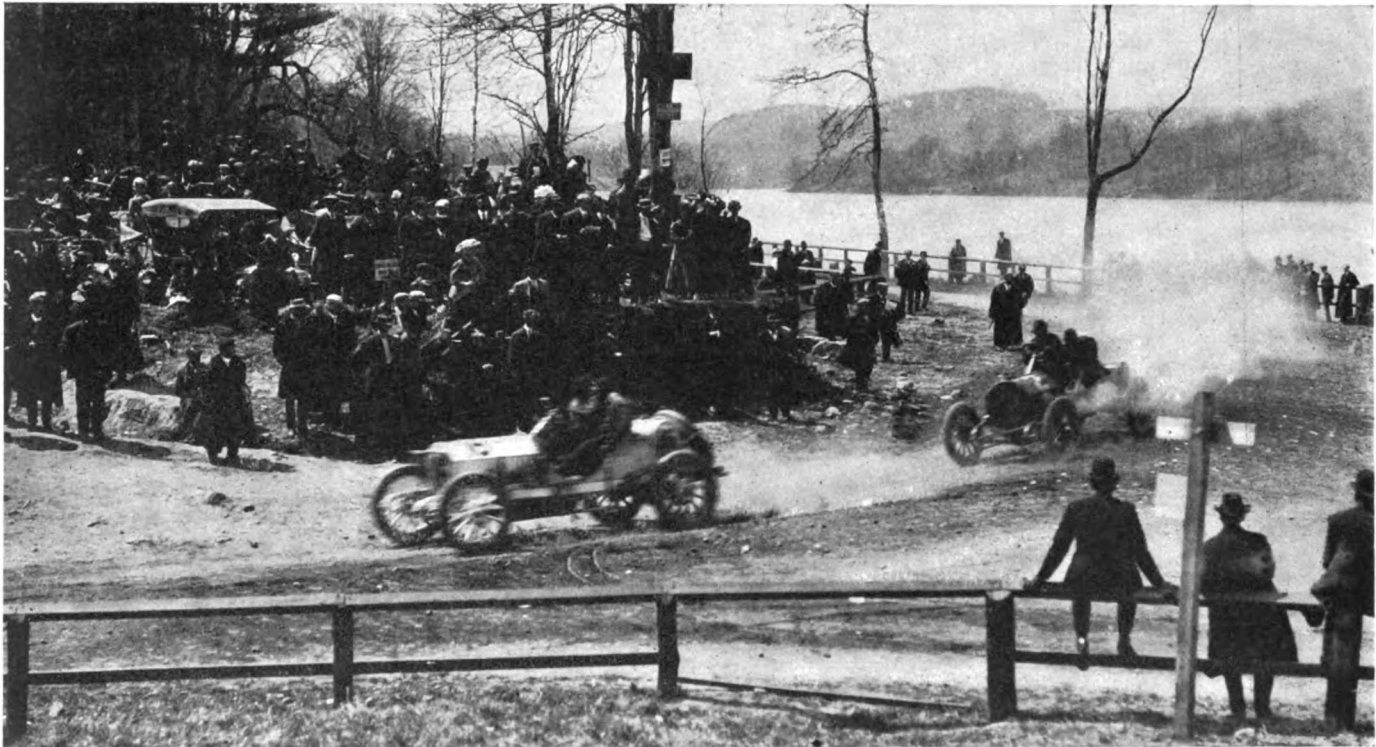

One of the Exciting Incidents of the Race—This Scene Is Along the Shores of the New Croton Reservoir.

Although it was true that tire troubles alone were not responsible for the delay, some of the drivers had far more than their share, as witness the experience of Michener and Mulford of the Loziers, Nos. 7 and 9. Thus Michener had to replace three tires and Mulford had to make four good, in addition to a later mishap to his mechanic which put him so far behind that it was useless to continue. Michener was unfortunate in having to replace every one of his damaged tires far from any of the outside assistance that the rules permitted where tires were concerned. On the first lap, a rear went bad right near the stand, costing six minutes. Later he ran two miles on a flat tire, then through the control at Mt. Kisco, this being on the sixth lap, while on the seventh he lost another. A loose cotter pin in the clutch pedal connection also cost him two minutes.

Mulford probably had more tire trouble than any other two drivers put together, as he had to replace a tire in each one of the four rounds that he made. On the fifth round Mulford's mechanic must have neglected to retard the spark, as he was rewarded with a back kick that threw him several feet into the air. Landing on his head on the road he was knocked unconscious. Mulford had to await the arrival of the ambulance and much time was lost.

In view of the unprecedented nature of the course on which



Bernin (Renault).



Mulford (Lozler).

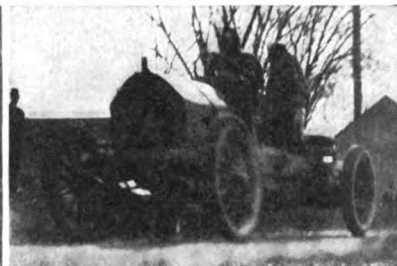

Seymour (Simplex).

they had to compete, many of the drivers figured out a schedule for themselves and stuck to it religiously, despite the temptation to speed a bit when it became evident that schedules did not win races, though they were striking evidence of regularity and reliability. Bernin and Bloch, in the two Renault cars, were good examples of this, the former losing 12 minutes on the second lap through a loose magneto, which sums up the entire troubles of both of the Frenchmen. They suffered no other delays either from their Michelin tires or mechanical causes, plugging their way round steadily at a good average pace.

The little Hol-Tan-Shawmut handled by Hilliard, which was only put in three days prior to the race, after having come over the road from Boston in record time, was another "scheduler" that showed surprising regularity of performance, not to mention lap times, that, in many instances, bettered those of their far more powerful competitors by several minutes. Considering the very short time that had been allowed for getting the car in shape, as its only running-in, outside of the usual factory test, consisted of three days on a stand in a garage, and the fact that Hilliard had hardly an opportunity to practice, much credit is due the car as well as the skillful manner in which it was handled. Its only stop was to replenish the gasoline tank, taking 1 1-2 minutes, while it averaged 46 1-2 minutes to the lap, the slowest being 49 minutes.

**Stearns Cars Suffered Odd Handicaps.**

Oldfield in the Stearns with the "No. 13" "hoodoo," found his bad luck in the fourth lap. During the bouncing and swinging round curves, his tool box had flung open and lost practically its entire contents, so that while on Valhalla hill, just after having passed the Bianchi, a stoppage of the motor placed him in a peculiar dilemma. It proved to be an obstruction in the gasoline feed line from the tank, but there was nothing to remedy it with. A few minutes' wait sufficed to allow enough gasoline to filter through to run a mile or so, and then there was another wait. This was repeated three times until the Stearns camp was reached, when the aid of a pair of pliers served to make things good. In the fourth or fifth lap, no less than three tires went flat, one of them while passing through the Mt. Kisco control.

Leland's delay in the "No. 5" Stearns was also "gasoline trouble." On the last lap he was stranded far from any supply

depot without any more "gas." The owner of a Winton touring car volunteered a replenishment, but the only means of transfer consisted of empty beer bottles so that the process was not a rapid one. Fourteen minutes were lost in this manner, in addition to which Leland also suffered one puncture in the fourth lap, which cost him five minutes, and two blowouts in the fifth lap just before arriving at the Mt. Kisco control and wasting another five minutes each, so that his delays totaled practically half an hour. After the race was over Vaughan found that he had also had gasoline trouble, the fuel leaking away from the auxiliary tank about as fast as it was being used from the main tank. Figuring the delay that this cost him, together with the others already chronicled, it will be seen that the "No. 8" Stearns was the most dangerous competitor that Strang had.

**Maja's Trouble Dated Before Race.**

Murphy, driving the sporty-looking little Maja, "No. 10," was certainly the victim of circumstances over which he had less control than did his competitors who suffered from delays caused by trouble occurring during the course of the race. His mishap originated some time before the race, and was due to the manner in which the wheels of his car were rebuilt by a local maker in putting the dismountable rim attachments on them. According to Murphy, who attracted universal admiration on the backstretches by the skill with which he handled the little car on the curves, the wheel was rebuilt with a fellow of several pieces of soft wood, instead of two sections of hard wood bent into form. Coming round the curve at Hawthorne corner, the wheel simply collapsed, the spokes being so loose that they pulled right out.

There was a prevailing general impression that Strang and his Isotta went through without a single stop, but this was not the case, as even the winner had troubles, too. On the sixth lap a stop had to be made at the Mt. Kisco control to replenish the gasoline supply, while in the very first lap a pin sheared off on the rocker arm of the change speed gear, preventing the shifting lever from being passed through the opening in the sector, so that only the third and fourth speeds were available after that. This made it a difficult matter to start the car, as it was necessary to race the motor every time to prevent stalling it, and all the bad places, particularly Valhalla hill and its turn, had to be taken on the third.



Murphy (Maja) Overhauling a Rival.



Where Pennsylvania Tires Were Supplied.





**How They Saw the Race.**—Long before nightfall of the day before the race the metropolitan automobiling fraternity began to make the history of the Briarcliff Trophy contest. A few hours later the general public added the factor of its racing enthusiasm and eagerness to be literally "in at the death," which the conditions seemed reasonably to promise. It was daylight on Friday, of course, before the cars and drivers were to furnish the struggle that had drawn these many many thousands to view the battle of steel, muscle and nerve that had been framed up and the tragic incidents that seemed assuredly imminent. Twenty-two American daredevils were to be recklessly cut loose over a narrow course with almost continuous sharp curves, bounded by dangerous ditches, stone walls, rivers and ponds the whole way, and replete with axle and spring racking and tire wrenching stretches, beside to risk limb and life in the wild scramble. The Briarcliff district is neither as familiar nor as accessible as the Nassau county circuit.

Thursday afternoon cars began to stream out Broadway and through the Hudson river towns. With nightfall their numbers increased, and by midnight there was an unbroken procession of gleaming headlights hurrying courseward. The hour for the closing of the course was an enigma. There had been official pronouncements that the entrance to the circuit would be barred between 2 and 3 o'clock, so that the majority cared not to risk missing securing a viewpoint by a past midnight start. As early as 1:45 A. M., a squad of pressmen set out for Tarrytown, where they had been put up for the half-night at the Maxwell-Briscoe factory. The road was then aglow with gleaming searchlights. Turning to the east streams of foot passengers lined the road. The course reached at East View, the midnight scene was one full of fire and life. Stands, large and small, had been erected along the roadside. On every furlong of the road to the start there were parking space speculators swinging their lanterns and hawking their spaces. In places there were bunches of a dozen or a score of cars parked in the skirting fields. Here and there at frequent intervals an isolated vantage point had been squatted upon, and one saw the camp fire of the all-nighters.

Approaching the grand and press stands at Briarcliff, the crowd of cars and people became denser, ending in a hopeless jam of machines and men at the start and finish point. En route were passed sky-larking processions of young men with arm badges telling that they were marshals. It is said that they were the much-boasted militiamen who were to guard the course. To one who had seen the businesslike soldiers at Savannah, it seemed a huge joke to call this military protection.

With the coming of daylight, the throngs of foot passengers from the incoming trains and the nearby towns increased. With rare common sense they climbed the encircling hills and avoided for the most part courting danger by standing along the edge of the road. There were crowds, of course, at the turns, and here the hired guards and volunteer marshals were concentrated, and made a show of keeping the crowds back and in order. The newspaper men en route noted that several of the makers had established parking camps for their customers. There were

parking grounds prepared by the Peerless and the American Locomotive people, and the Maxwell-Briscoe Company had pitched a veritable Maxwell camp on a commanding hill.

**"No. 13" Almost a Hoodoo for Barney.**—Barney Oldfield did not quite get away with his hoodoo number, for Stearns car "No. 13" very nearly justified the universal feeling about the number in the very first lap of the race. It was just 5:30 o'clock in the cold gray dawn of the morning when Barney narrowly escaped being thrown into kingdomcome by the special train from New York on the Putnam division at the State road crossing, half a mile from Kitchawan. A special from New York, consisting of an engine, tender and seven cars, whistled for the crossing and bore down upon it. Just as the whistle sounded, the spectators were horrified to see a racing machine bearing the fateful "13" come tearing along at a speed of over 50 miles an hour and loom up through the fog from around the curve which hid the track from view. The flagman made a jump for the track and wildly waved to the engineer to stop. The train itself was bowling along at a good trip, and, in spite of the fact that the engineer promptly clamped on his airbrakes and reversed, the train slid along the track until the cowcatcher stood half way over the crossing. There were just two things for Barney to do. He had either to swerve and go over the rails below the crossing, thereby courting instant mishap, or take a chance and skim by the cowcatcher as it protruded across the right-of-way. In a second's thought he chose the latter, and those present were treated to a bit of daring and clever steering, for Barney, to make sure, put on more speed and went at it. The off-wheels of his big Stearns grazed the projecting cowcatcher as he went by, and it tilted the machine until it assumed an angle of 45 degrees. All held their breath, but the minute the car left the cowcatcher it righted itself, and Barney was off, cigar still in mouth, while the engineer reversed his train farther up the track.

**Confusion on the Grandstand.**—Stories of the demoralization in the conduct of the grandstand are afloat. There would seem to have been neither head nor tail to the management of this important feature of the race. The ushers proved inexcusably incompetent in seating those who had bought tickets. Seat-holders boldly preempted boxes and refused to be dislodged, and no one appears to have been available for an appeal or redress. The wife and several women friends of one importer, who had several cars in the race, were practically fired out of his boxes back into the seats by a party of male and female roysterers of the "Tenderloin" type, who showed corresponding number reserved seat coupons and insisted that they entitled them to the box. A bearded usher, who was summoned by the importer, accepted the addition of another drink to his ample cargo, and was quickly won over to the side of the intruders. Even when the importer left his 'phone to seek relief, he could find no one in authority from whom he could get satisfaction, and had to submit to his wife and her guests being driven from their boxes.



Referee Pardington, Chairman Morrell, Starter Wagner, et al.

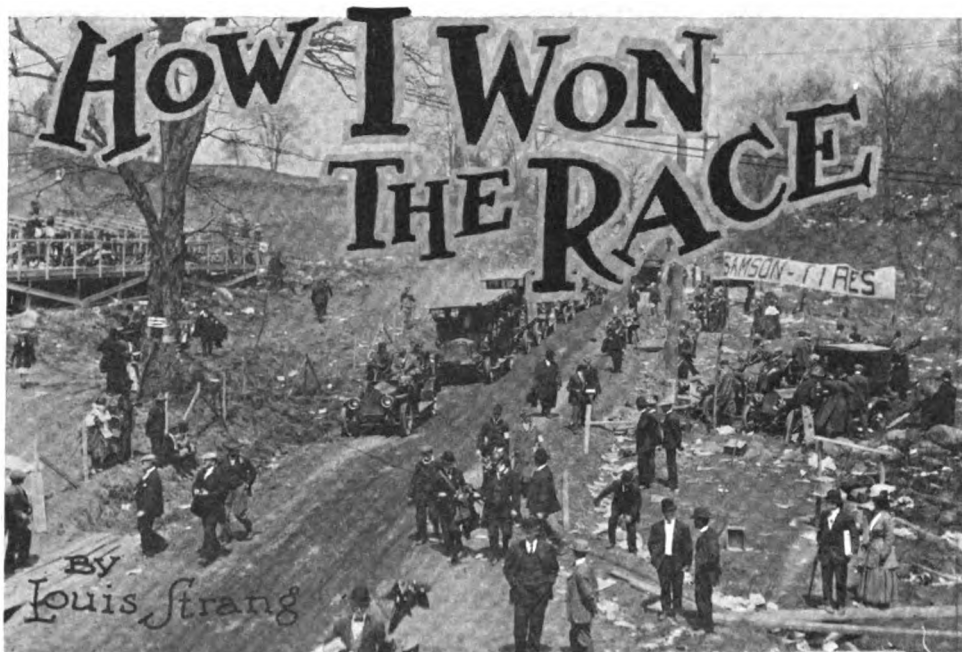

and filled up our tanks at our control, just outside of Mt. Kisco; this was the only stop we made while outside of the Mt. Kisco control.

A great deal of the credit of our victory belongs to Marquise, who sat in the mechanic's seat. Being naturally careful, he kept me from getting reckless at any time, and a good man with you is all your race.

From what I have seen of road racing I think that a driver should never be instructed to hold back, for a race starts right from the word "go," and time lost can never be regained. No race has been won from laying back, unless the leading cars broke down, and then it's only a gamble. So, to talk of going easy for half a race and then going out to make time, is too hard on the driver, for the others have already gotten a lead that may prove impossible to cut down.

My only regret is that I didn't have the wheel of an American car, and

I hope some day to pilot an American car to victory against the best that Europe can turn out. The E. R. Thomas Company is sending over a Grand Prix entry, and I know that all true Americans will wish me the greatest success, for I am going to drive it.

### THOMAS SECURES STRANG FOR GRAND PRIX.

Louis Strang, who followed up his victory in the Savannah Cup race by winning the Briarcliff trophy, and thereby came pretty near preempting the top rung of the American racing ladder, is to represent this country in the Grand Prix. Harry S. Houpt, acting for the E. R. Thomas Motor Company, with characteristic hustle, has secured his services and those of his mechanic, J. B. Marquise, as crew of the Thomas Candidate for international honors in the great contest in France on July 8. Mr. Houpt will sail with Strang and Marquise on May 15, see to securing training quarters, and be their mentor and manager in the race and during the preliminary practice. The securing of Strang and Marquise was made possible through the generous

**A**FTER the drawing for starting positions had taken place, and I had looked over the order of the start, I decided that Cedrino of Fiat No. 2 was the man that I had to beat, and that if I didn't get him in the first couple of laps I would never win. So when Wagner gave the word "go," I started right out and drove every curve the limit, and got every bit of speed out of the car that there was in it. There was a fog bank that was very bad, and my perfect knowledge of the road undoubtedly gave me a great advantage over the other men ahead of me, who had to "feel" their way through the mist while I drove wide open, and knowing just where the corners were, was able to shut off, scoot around, then open up again, and rush onward. I caught Lytle and Sartori right after leaving Eastview. Cedrino had already passed these two. I passed Cedrino about twenty-five feet out of Pleasantville turn.

I drove very hard for possibly a couple of miles, and, after asking Marquise if everything was clear behind, I began taking it a little easier, and drove carefully from then on until the end of the race. We had a private telephone wire from the stand to a signal board at Eastview where I got my relative position and time during the entire race, so I knew just how hard I had to drive. Also at the Mt. Kisco control Mr. Moscovics, of the Allen-Kingston, very kindly showed me a score card on every lap and kept me posted as to all the news of the race.

I had no tire trouble at all, as I cut out all "grand stand" corner work, drove all corners easy and never skidded an inch at any time. My brakes were new, and the shoes wore down until they wouldn't hold, and Marquise got down on the floor boards, and, leaning under the car, tightened them up until they held perfectly. A strap which we had on the back of the car came loose, and threatened to run into the rear sprocket; Marquise climbed out of his seat over the gasoline tank to the end of the car and then back again, and we didn't have to stop even for that. We stopped on our sixth lap



Poolle (Isotta) Making the Dust Fly at One of the Soft Turns.

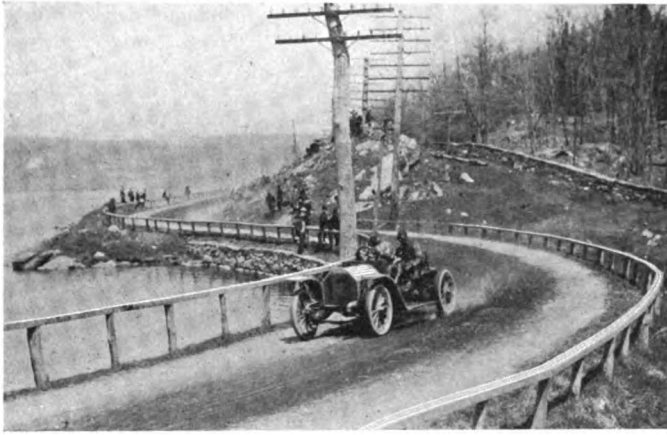

Once More Barney Oldfield, Making an "S" Turn.

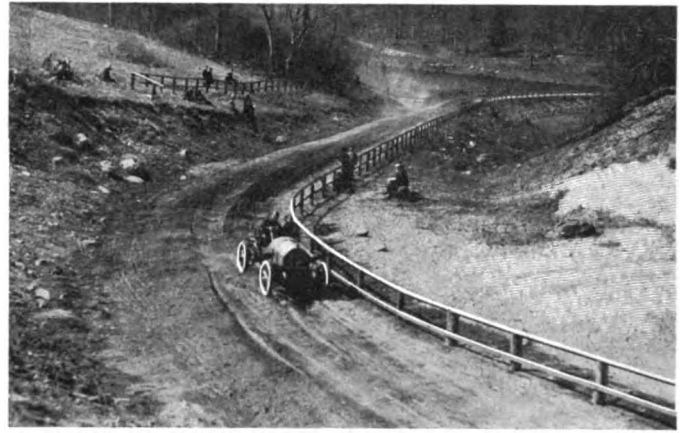

Roberts (Thomas) Making One of the Picturesque Turns.

and sportsmanlike conduct of J. H. Tyson, with whose Isotta car they won both the Savannah and Westchester races, in granting them a leave of absence for the purpose.

Two Thomas cars will be sent over. Strang and Marquise will go to the E. R. Thomas Motor Company's factory at Buffalo to look them over before their shipment.

It is said that A. L. Riker had made advances to Strang with a view to getting him to pilot a Locomobile car, which he thought of entering under the double fee provisions of the rules as to late nominations. Whether Mr. Riker will persevere in his plan to have the Locomobile Company represented in the Grand Prix remains to be seen.

#### Strang Has Driven Many Makes of Cars.

The story of Louis Strang's automobile life discloses a wider familiarity and experience with motor cars than one would look for in one so young, for he is but twenty-three years old, having been born at Amsterdam, N. Y., August 14, 1884. He was educated there and later at a private school at Scarborough, near the Briarcliff course. His mother, who was a woman of considerable property, lost her money in Chicago gas stock and Louis had to go to work. Later his mother died, leaving three sisters for him to support, one of whom is now married. He started as a typewriter with H. H. Franklin, who was then a maker of them, and thus later became familiar with autos.

Strang became a chauffeur in this city, first driving Franklin No. 4. He then went with H. P. Robbins, and toured Europe as his chauffeur, a Panhard having been purchased on the other side from Henry Farman, the racing man. On his return to this country, Strang demonstrated the French Berliet for Mendel, Dale & Co., its American agents at that time. His next employer was H. O. Havemeyer, the "Sugar King," who leaned toward the Mercedes.

Strang got his first racing experience as demonstrator for Joseph Heller, an importer, through driving his Pipe car in

the straightaway races at Long Branch. He next went with E. C. Hoyt, president of the Leather Trust, and then returned to demonstrating under E. B. Gallaher, importer of the Richard Braier. Then he looked after a pair of Renaults for C. B. Hudson, a race track man, the intimate friend of John A. Drake.

Walter Christie next secured him for his mechanic in the elimination trials and Vanderbilt Cup race of 1906. Strang then looked after Robert Maxwell's Panhard.

Last year the Briarcliff Trophy winner was Christie's mechanic in the Grand Prix. On his return he went with the Pilain agency, driving one of its cars in the 24 hour race at Brighton Beach last season. After this he was chauffeur to E. C. Clark, the son of Bishop Potter's wife, whom he left to go with Christie in his Southern track racing tour. After Christie's accident, Strang drove the car.

John H. Tyson, the twenty-two year old sportsman, was his next and is his present employer. Strang was sent to Savannah to drive the Isotta Fraschini that Mr. Tyson had ordered direct from Italy. It was not on hand when he reached Savannah, so he studied the course in a touring car. How he won is history.

Strang's practice for the Briarcliff race consisted of six rounds of the course in a Franklin and one try-out lap in the Isotta he was to drive in the race. "I attribute the greater part of my success as a driver," said Strang, "to the instructions I received from Emil Stricker. Stricker came to this country when the Daimler Manufacturing Company bought the American rights to manufacture the Mercedes. Later he was a demonstrator for the late Alexander Fisher, who then imported the Rochet-Schneider. It was while he was with Mr. Fisher that he gave me the driving lessons I have always remembered and followed. He taught me how to turn curves, how to hold the steering wheel at the bottom, and above all not to touch any lever until I was ready to use it. Stricker has now an interest in the Porthos Company, in Germany. He drove a Porthos in the last Grand Prix, and now we will be fellow-competitors."



Lytle (Apperson) Burning Up the Road.



Stone Fences Supplied Safe Vantage Points.

# A BUDGET OF NEWS FROM THE FRENCH CAPITAL

By W. F. BRADLEY.

PARIS, April 25.—As the result of the run from Paris to Nice and return, a distance of 1,400 miles, the spring wheel competition has once more proved that automobiles are not entirely dependent on pneumatic tires, but the test has also brought to light the fact that all the systems put on the market are not suited for rough usage. There was practically nothing that was new in the third annual competition, the systems represented having all been shown to the public in the annual exhibitions at the Grand Palais.

The winner of the competition is Ducasble, which finished without any repairs, made the fastest average time and was in good trim at the end. It is a tire which has been on the market for some time, and was used on one of the French cars starting from New York on the run to Paris. In this case, however, the tires had to be changed for pneumatics before Cleveland was reached, and the car abandoned later. This particular substitute has been more fortunate in the French test, for three sets of tires finished at the head, and will probably get first positions when the committee has finished its examination. The Ducasble tire is composed of a series of small air chambers, each one of which is emptied of its air when put under pressure and filled by suction as soon as weight is removed.

Sider tires stood the test well, if one may judge by the condition of the bandages of the four cars equipped with this make. A Darracq and two Rebour runabouts, as well as an Alcyon runabout, finished the run without any trouble, and had their tires in excellent shape on arriving at Paris. This tire has all the earmarks of a pneumatic casing, but instead of being filled with an air chamber has a series of circular sheet steel springs with a layer of rubber between each and united by a chain. The method of mounting is the same as for a pneumatic tire. Instead of an inner tube, however, there are circular blocks of wood, which act as a wedge between the heels of the tire, keeping it fixed on the rim, and are themselves secured by bolts passing through the felloe. In the case of a very severe blow, it is not the rim but the block of wood in the place usually occupied by the air chamber which would receive the shock.

## Masses of Springs Are Being Discarded by Wheel Makers.

Spring wheels of the type which were so much to the front a few years ago, obtaining their elasticity from a mass of springs, are very little seen now. A proof of this is obtained in this competition, where the three most successful makes have ordinary fixed spokes and some special type of rubber or spring bandage, or a combination of the two. One other make which may be put in this category is the M. Y. G., composed of heavy blocks of rubber perforated transversely. There are twelve blocks for a large wheel, each one being held by means of a bolt passing through the felloe. Two examples of this system were shown, one being on a heavy Delaunay-Belleville limousine with inside steering, and the other a large Peugeot touring car. The fastening of some of the blocks appeared to be somewhat defective, but otherwise the wheels on both cars were in good condition.

Among the double-rim type was the Metallo-Elastic, which obtained its elasticity from a series of rubber balls in a cage between the two surfaces. On a small car the system had acted very satisfactorily, one of the wheels dismantled for inspection being in excellent condition. On a heavier Darracq car, however, the friction had caused heating to such an extent that a leather band holding the balls together in a series had been burned through, and the balls themselves had begun to show serious signs of breakdown.

There were two types of pivoting spring spokes which managed to finish the run, but neither presented any very attractive features, being much too heavy for ordinary use and not suitable

for fast work. Of the nineteen cars which started from Paris, fourteen returned, but of these several had suffered penalization en route, the official finishers being but nine.

## S. A. Miles Arrives in Paris, Pierce Arrow Route.

There is a genuine fear among automobile dealers, garage proprietors and hotel proprietors in Paris, and generally throughout France, that the number of American visitors this season will be smaller than usual, owing to the financial depression, which appears to have shocked Europe much more than America. The fear will probably be ill-founded, for automobilists from across the Atlantic are already arriving, though the season has hardly begun.

S. A. Miles, general manager of the N. A. A. M., arrived here recently on his 40-horsepower Pierce Great Arrow car. He is accompanied by Mrs. Miles, and had as a traveling companion from London to Paris Arthur Lumsden, manager of the Goodrich Tire Company's London house. After several days in Paris, made busy by visits to aeronautical and automobile factories, principal among them being the huge Renault establishment at Billancourt, where Szisz inquired eagerly after the prospects of another Vanderbilt race, Mr. and Mrs. Miles left for the Château district and the south of France. In a couple of months they will probably return North, pass through Paris, and make a brief run through England, before embarking for America.

Mr. Miles expressed his delight at the really practical manner in which the various associations in Europe made touring for foreign visitors an even simpler matter than it is in their own country. In this connection, Victor Breyer, the A. A. A. delegate in Paris, is now installed in his new offices, at 4 bis Rue Descombes, and reports a complete organization for members of the association who need touring information and assistance in Paris.

Secretary Lambert, of the St. Louis Aero Club, has been in Paris several weeks, accompanied by his wife, and has naturally spent much time at the French club's aero ground and at the flights of Delagrange, Farman and others in the neighborhood of Paris. Last week Secretary Lambert made an unaccompanied ascent in the *Cythere*, of 600 cubic meters capacity, rising from the Saint Cloud Park and descending at Limours.

## French Makers and the Vanderbilt Cup Race.

French constructors appear to have just awakened to the fact that a Vanderbilt Cup race will be held this year, and, with the awakening, is a realization that the conditions are not what they would prefer. The large majority of builders ask why the international rules, adopted by the Ostend conference, are not adopted for the great American race. In view of the fact that the A. C. A. delegates were present at the conference and voted these rules, French automobilists are at a loss to understand why these international conditions have only been adopted in a very limited degree. It should be explained that the average Frenchman does not appreciate the shades of difference between the A. A. A. and the A. C. A., and argues that since America voted the rules, America ought to live up to them. No preparations whatever have been made for the race, the general impression being that the announced conditions are tentative, and that later the 155-millimeter rule will be adopted. It is doubtful, indeed, if any foreign representation can be obtained under any other conditions, for no factory in Europe intends to build more than one set of racers for the 1908 season. The desire is expressed in certain quarters that there be a progressive reduction of the entrance fee when two or three cars are entered by one firm. This has been done for the Grand Prix and the A. C. F. voiturette race this year, and these are considered to have established a precedent that should be followed in the Vanderbilt race.



### "RUBBERNECK" WAGONS WANTED IN TEXAS.

Texas is nothing if not progressive, and the prevailing spirit is the same whether it happens to reside in one of the larger cities or in one of those places that it is difficult to locate on the map even with the aid of a microscope. Certain evidence of this is to be found in the fact that, after much investigation, "Searcher No. 12," of the New York post-office, wrote across a particular piece of mail matter, "Try 949 Broadway." The envelope in question bore the following (it would be a stretch of courtesy to call it an address):

Automobile co  
The American Rubberneck,  
New York.  
care of W. E. Sebree  
Originator

Only the words in the upper righthand corner and the direction of the postal searcher prevented the missive from being sent to that vast storehouse of unanswered correspondence, the "Dead Letter" office, and in that case the following gem would never have seen the light.

W. E. SEBREE:

Sir.—You will find enclosed a clipping from the "Woman's National Daily," a paper published in St. Louis, of which I am a subscriber, and seeing your "ad," write you. I am trying to find an automobile house that can put me up which I so much desire in this line for the people of this country. First, I want a car that will carry at least fourteen passengers and 1,000 pounds of baggage and travel over the hills, and pull the sand and mud. I have several men wanting machines for different purposes—two or three for stage lines—also they want a large and substantial auto, something to rely on in all constructions. Now I mean business. Send all your cuts, catalogues, and special prices to agents at once. Or send a man here at once to help me choose these sales they are anxiously awaiting some one who has the machine that can and they will not be afraid to demonstrate them. You and I can do a business here at once for ourselves to start the agency for Texas. Honorably yours for business.

B. W. HONEYCUT.

Brady, Texas.

The clipping referred to is headed "Rubbernecks for London," and reads as follows:

London, April 7.—The American rubberneck sightseeing automobile is to be given a chance in London. W. E. Sebree, originator of the rubberneck wagon in New York, is behind the plan to install them here. Three of the big cars, carrying 37 persons, in charge of megaphone instructors, will be installed. If they prove successful more cars will be installed and the innovation will then be tried in Paris and other European capitals.

### TAKING CARS ACROSS THE BORDER.

Touring across the border in Canada will be facilitated by the conditions now prevailing. According to "The Official Automobile Blue Book," from which the following information is taken, automobiles may now be imported into Canada, duty free for three months, the importation to be reported on a prescribed form at the custom house at the point of entry, an examination and appraisal being made. An invoice showing the selling price of the car must be produced, a cash deposit of \$25 made, and a bond signed in double the amount of the estimated duty.

The principal points of entry are at Niagara Falls, Ont., reached by way of Buffalo, N. Y., and Windsor, Ont., across the river from Detroit, Mich. For these points the C. S. Warner Company, 31 Clifton avenue, Niagara Falls, Ont., will arrange all details including bond, registration, driving license and the like at a cost not exceeding \$10, and no cash deposit will be required. Quebec, P. Q., is another important point which may be reached via Rouses Point, N. Y., to Lacolle, Que., St. Albans, Vt., to St. Armand, Que., Malone, N. Y., to Athelstan, Que., Ogdensburg, N. Y., to Prescott, Que., Newport and Richford, Vt., to Mansonville, Que. and Lowellton, Me., to Beauce, Que.

New Brunswick may be reached by way of Vanceboro, Me., to McAdam Junction, N. B., or Houlton, Me., to Woodstock, N. B., while Nova Scotia, being practically surrounded by water, would generally be approached by the tourist on a steamer

and there are custom houses at all ports of entry. Tourists into Quebec who have not previously secured registration and driving permits may obtain them upon entry into the Province from the following customs, or provincial officials:

Athelstan ..... Wm. Saunders, Sub-Collector.  
Coaticook ..... J. B. Daly, Collector.  
Comins Mills ..... W. C. Kingsbury, Sub-Collector.  
Cookshire ..... A. Ross, Collector.  
Dundee ..... John D. McMillan, Sub-Collector.  
Freelighsburg ..... J. H. Baker, Sub-Collector.  
Hereford ..... Austin Hunt, Preventive Officer.  
Lacolle ..... J. A. Paquet, Sub-Collector.  
Lake Megantic ..... A. B. Gendreau, Sub-Collector.  
Mansonville Station ..... H. A. Gilman, Preventive Officer.  
Noyan Junction ..... W. M. Jameson, Preventive Officer.  
Phillipsburg ..... P. E. Luke, Sub-Collector.  
St. Armand ..... E. A. Bourret, Collector.  
Stanstead Junction ..... C. F. Bellam, Sub-Collector.

#### Collectors of Provisional Revenues.

Quebec ..... J. E. Fortier.  
Montreal ..... S. P. Leet.  
Sherbrooke ..... Morkill & Lefebvre.  
Cowansville ..... J. McCrum.  
Hull ..... T. W. Symmes.

#### Inspector of Provincial Revenue.

Lévis ..... T. A. Poston.

They may also be obtained from the department at Quebec by applying to A. Brosnan, comptroller of Provincial revenue, treasury department, Quebec.

### A. S. M. E. TO DISCUSS AUTO CLUTCHES.

At its next regular monthly meeting, to be held in the Engineering Societies building, 27 West Thirty-ninth street, the American Society of Mechanical Engineers will devote its session to a paper on "Clutches, with Special Reference to the Types Used on Automobiles," by Henry Souther. The development of the various types will be illustrated by means of lantern slides. The meeting will afford an excellent opportunity for the full discussion of the design and use of clutches for all purposes, and it will be continued at the semi-annual meeting of the society at Detroit, June 23-26. The members of the Society of Automobile Engineers have been invited to join in this discussion at Detroit, the third annual summer meeting of the latter being scheduled for June 25-27.

### NEW BOOKS FOR AUTOMOBILISTS.

**European Automobile Annual.**—For the third year in succession Baudry de Saunier's "Annual" of the European automobile industry makes its appearance, similar in general appearance to its predecessors, but enlarged and modified in detail. The compiler of the Annual first seized upon the idea of producing a trade directory giving in alphabetical order everything that the private automobilist or the dealer might possibly desire to know about an automobile or the industry in Europe. Proof of the need of a volume of this nature is found in the sale it has had in France and the fact that foreign publishers have not hesitated to make literal copies.

As a reference book for firms having relations with France and other parts of Europe, the "Annual 1908" is a particularly valuable work, for it gives in the most accessible manner possible information on every constructor in France, the models he produces, explanation of technical terms, the results of all races, lists of members of all the important automobile clubs, the names of all agents and dealers, brief sketches of notable persons in the automobile industry or sport—in brief, it is a complete handbook of the French automobile industry, compiled, for convenient reference, in alphabetical order. The volume, which is well illustrated and handsomely produced, consists of almost a thousand closely printed pages. It is published by L. Baudry de Saunier, 20 Rue Duret, Paris.

## LETTERS INTERESTING AND INSTRUCTIVE

### INTERESTING QUESTIONS ABOUT A FORD.

Editor THE AUTOMOBILE:

[1,331.]—I have some interesting questions which I wish to have answered through "Letters Interesting and Instructive." I have a Ford, Model F, 16-horsepower, double-opposed motor, on which the pistons were found to be worn so badly that I had new ones provided. The cylinders were also rebored and the valves ground in at the same time. The engine was then reassembled, valves adjusted and timed, and the piping put back in exactly the same manner as it had been previously, all the joints being made tight.

The engine now compresses well on one cylinder and only slightly on the other cylinder, but the cylinder which has poor compression develops as much power as before, while the cylinder with good compression has scarcely enough power to run the engine. A Schebler carbureter is employed, and the suction of the air through it is the same, apparently, for each cylinder. What is the trouble?

Jacksonville, Ill.

F. C. CARRIEL.

Without any further data than what is given in your letter, it seems to us that the trouble can be traced to improper valve and ignition timing. We should advise you to check this over very carefully and see that both the inlet and exhaust valves open and close at exactly the right time; also that the ignition is timed right, as the latter alone might account for the lack of power. You do not say anything about the valve-operating mechanism having been renewed, or checked up for wear, and the difference in the length of the valve stems, the wear on the cams and rollers, etc., may be sufficient to throw the timing out considerably, although it apparently is correct. It will be evident that if the exhaust valve opens too soon much of the power will be lost; or, if the inlet valve remains open too long, much of the charge will be ejected and the compression will naturally seem to be poor when the engine is turned over by hand.

Granted that the cylinders and pistons are tight, which should certainly be the case in view of the work that you have had done on the car, there appears to be little else that can be responsible for the trouble, and we think that if you will go over this part of the engine you will not be long in finding the cause.

### STEERING OF THE CHRISTIE AND THE CABS.

Editor THE AUTOMOBILE:

[1,332.]—In a recent discussion, I heard it stated that Walter Christie's 130-horsepower racing car, which he used in the 1907 Grand Prix, was steered by the rear wheels. Kindly let me know if this is so; also if the electric hansoms which are used in New York as taxicabs, steer by the rear wheels.

Garden City, N. Y.

J. BERNARD MILLER.

Christie's racing car, as well as all the cars of the front-driven type that he has turned out, have been built to steer by the front wheels in the usual manner. These wheels are connected to the driving shaft, which is the crankshaft of the motor itself, when on the high speed, through the medium of universal joints which compensate for their lack of alignment when turning corners. Some of the original electric cabs used in New York City were designed to steer by the rear wheels, but we are under the impression that very few, if any, of this type still exist.

### ADVANTAGES OF TIRE-FILLING COMPOUNDS.

Editor THE AUTOMOBILE:

[1,333.]—Please give me your opinion if it is advisable to use tires filled with such compounds as glue, glycerine and other ingredients mentioned by you in a recent issue. What are the advantages and disadvantages of such fillings?

Davenport, Ia.

G. TREIMER.

The chief advantage of using tires filled with such compounds is that they are proof against punctures and similar forms of injury. On the other hand, they have the disadvantage of greatly increased weight, loss of resilience to a certain extent, and the difficulty of repairing the tire after it has been filled with these compounds. Probably there are some readers who have had extended experience with tires that have been filled and can give more definite details of both sides of the subject.

### ABOUT CONNECTING UP ACCUMULATORS.

Editor THE AUTOMOBILE:

[1,334.]—The manufacturers of a certain car place emphasis on their instructions to always connect up the storage battery in the same way, the positive pole to the coil and the negative to the ground. Another authority claims that in passing from one point to another the electric current carries particles of metal with it—e.g., in the case of timer, vibrator points and spark plugs, one point would be eaten away and the other built up. Hence, he advises reversing the poles of the battery each time it is replaced. Is there any merit in this, or is there any reason for keeping the battery always the same?

H. F. CLARK.

Ventura, Cal.

There is no reason that we know of why the battery connections should always be the same in order to obtain satisfactory ignition service. The authority in question is quite correct, and this action is particularly noticeable in the case of the coil vibrator contact points, less so in the case of the timer, and is absolutely a negligible factor where the spark plug is concerned, owing to the infinitesimal quantity of current passing at the gap of the latter. The action is exactly the same as that of the ordinary arc light, which, when trimmed, is supplied with a negative carbon but half the length of the positive. At the end of its usual period of burning, there is scarcely anything left of the positive carbon, while the negative has hardly decreased in size at all. The action naturally depends upon the amount of current passing, *i.e.*, the amperage. We think it is good practice to reverse the connections each time the battery is replaced.

### LEADING AN INQUIRER ASTRAY.

Editor THE AUTOMOBILE:

[1,335.]—It seems that your answer to Mr. Sharkey, Letter No. 1,311, is misleading. His question is plain, though he evidently does not understand the ignition system. I think you will agree with me that his car is all right as it stands, as disconnecting the spark plug could not affect the vibration of the coil.

Cleveland, O.

ANOLDTIMER.

We do not agree with you that the car in question is "all right as it stands," by which you mean its condition as described by the inquirer in question. Your statement that "disconnecting the spark plug *could not* affect the vibration of the coil" is akin to that of the young attorney called upon to get a client out of jail. "Why, man alive, they can't arrest you for that." "I know that," replied the client, "but they have arrested me." Mr. Sharkey states, "When the engine is turned over with the terminal disconnected, the coil vibrates." We informed him that this should not be the case, in answer to his direct inquiry to that effect, and also tried to suggest what appeared to be a cause for it. It goes without saying that this may not actually be the cause of the trouble, but apart from this, we do not consider the answer at all misleading and would like to hear more about it.

### INTERESTING CAPITAL IN A NEW STEAMER.

Editor THE AUTOMOBILE:

[1,136.]—Do you consider there is a good field open for a steam automobile of various models, built as good as the best steam car made to-day, with various improvements, such as a kerosene burner, no air pressure, perfect separation of oil from condensed steam, condenser sufficient to condense all the water used, possibly a steam turbine; but if not, a new compound steam engine?

If so, do you suppose it would be possible to interest fifty or a hundred thousand dollars for such a proposition?

Nyack, N. Y.

STEAM.

There is no apparent reason why a well-built steam car along the lines you indicate, turned out by a progressive concern, should lack for a market. Merely because the cars of this type at present being built are in the minority, so far as the number of makers devoted to steam is concerned, is no reason to infer that this is due to the fact that the market for such a car is very limited. It is not easy to build a successful steam car, and this

probably has a good deal to do with it. The possibility of interesting capital is something a bit beyond our ken, but we have no doubt that the right man could do it.

### MATERIAL FOR AUTO STEERING KNUCKLES.

Editor THE AUTOMOBILE:

[1,337.]—Please inform me through "Letters Interesting and Instructive" as to the properties required in metal for front axle yokes and knuckles. I suppose toughness and hardness are both required. Is manganese bronze a good material for this? In what respect does it differ from better grades of cast and drop forged steel?  
Quitman, Ga.

W. MATHEWS, M.D.

Maximum toughness and hardness are both prime requisites for material to be employed in the construction of steering knuckles and front axle yokes of an automobile. We have known of one or two instances in which manganese bronze has been employed for front axle yokes, the yokes being cast integral with the axle in one piece. So far as we know, the same material has not been used for making the steering knuckles. It has not been extensively employed owing to the greater weight necessary to attain the same result as compared with drop-forgings of alloy steel. Cast steel would not be a good material to employ for steering knuckles, although it has doubtless figured in this rôle on some of the cheaper cars. The parts in question form such a vital factor in the safety of a car that no material can be too good for them. Both the tensile strength and elastic limit of the alloy steels employed for automobile work are higher than is ordinarily attainable with manganese bronze castings, so that drop-forgings of the former naturally weigh much less for the same strength.

### ELECTRICAL THEORY OF THE METER QUESTION.

Editor THE AUTOMOBILE:

[1,338.]—In regard to letter No. 1,292, I may help you a little. The current flowing in any circuit is the total voltage divided by the total resistance of the circuit. Let us suppose that the voltage of four dry cells is 5.2 volts, their internal resistance plus that of the primary of the coil and the wiring, 4 ohms. If the American ammeter had a resistance of 5 ohms and the French ammeter 2 ohms, which is relatively possible, the total resistance of the primary circuit when the American meter is used would be 9 ohms and the current  $\frac{5.2}{9} = 5.8$  amperes, and 6 ohms when the French meter was used, giving  $\frac{5.2}{6} = 8.7$  amperes. Both meters might be

correct, providing the reading indicated was 5.8 and 8.7 amperes respectively. I have taken values merely to illustrate my point.

Furthermore, the tests made do not show much. To be reliable tests, both instruments should have been connected in series with a steady source of current, such as a storage battery, and both instruments read at the same instant. If this was done when the given readings were taken, it only shows that the instrument differs; it does not show which was correct, unless the following information was also secured: The voltage across the terminals of the battery, while the ammeters were being read, and secured by means of a suitable voltmeter that is known to be correct, and the correct resistance of the circuit. This latter should have been measured by a Wheatstone bridge that is known to be correct. Then the correct current could have been calculated. Or an ammeter of suitable range and known to be correct could have been connected in series with both the French and the American instruments, and all three read at the same time.

It may be well to state that the instruments sold for measuring the current from primary cells or storage batteries by automobilists are not usually much better than mere current indicators. For this purpose they are all right and good enough, but they seldom give the current correctly in amperes; in other words, they are not correct reading ammeters. If one has such an instrument and knows what indications it should give for the successful operation of his coil, good ignition, and fair life for his batteries, he is fortunate, and can then make good use of his instrument. With the same number and kind of batteries, its reading is approximately proportional to the current in amperes, probably close enough for practical purposes.

There is another source of error that I have not mentioned, and that is the inductance of the meters. In a primary circuit, the current is rapidly interrupted and the instrument having the greater inductance would produce the greater reduction in the strength of the current, and hence tend to give a smaller reading, unless both instruments had been calibrated with currents interrupted at the same frequency or rate

H. S. WEBB.

Scranton, Pa.

### FIVE YEARS' SERVICE WITH A CADILLAC.

Editor THE AUTOMOBILE:

[1,339.]—I am interested in your reply to the letter No. 1,312, from Mr. Harrington, in your issue of April 16, about repairs to a Model H Cadillac. I have driven a Model H every year since I bought her in 1903, and she runs better now than she did at first. Of course, I have had her overhauled every winter and worn parts replaced. Last summer I took her on a long trip through Northern New England and a little way into Canada, making a tour of the White Mountains on my way home, and though she has only one cylinder, I found that she could go anywhere that the big fellows could with their four and six cylinders.

I have had the same experience with a worn piston and rings that Mr. Harrington has, and the only thing to do is to buy a new piston. It will cost four or five dollars and the rings eighty cents apiece. If he tries to turn new grooves in the old piston and make special rings, it will certainly cost more, and besides he will always have to have special rings made afterwards, which will cost more.

I have always used medium or light grade Valvoline oil in my engine, and it gives good satisfaction. The great secret of successful lubrication of this engine is to keep always enough oil in the crankcase to cover the bottom from 1-4 to 3-8 of an inch deep. I used to take off the cover of the crankcase and measure the depth of the oil every day, but now I have a drip cock arranged in the bottom of the crankcase and I can keep the oil at the right depth.

I don't think the popping Mr. Harrington asks about is in the carbureter. In all my experience with the Cadillac I have never had a backfire through the carbureter that I know of. In my opinion the popping is caused by the spark plug not being inserted right. The plug in this engine is a special one, about two inches in diameter, and if any dirt gets between the engine and the plug, or if it is not seated properly, a little space is left through which some of the exploding charge will come and make an unmistakable "pop." This is especially so when a heavy load is thrown on the engine, as in starting, or climbing a stiff grade, for then the explosions are stronger. When the engine is running light, the explosions are often not strong enough to get through the space between the spark plug and the engine as above.

Hartford, Conn.

ARTHUR PERKINS.

### STEEL TIRED STEAMER SOON ON THE ROAD.

Editor THE AUTOMOBILE:

[1,340.]—My steel tired auto is set up and I am now setting the engines. They are designed to set upright. I am laying them down in a tight box under the floor with a leather end to the box and with two holes for the chain to pass through.

All the automobile men here tell me that it will not work without a differential. I have proved that it will by this simple experiment. I turn the two front wheels as far as they will go, then with one finger hooked on one tooth of the sprocket on drive axle I can run it across the floor and see the wheels slip. The auto with engine weighs 925 pounds, the boiler 300. The day will come when steel tires will be as common as steel-tired wagons and no differential. The actual saving over a good set of auto wheels, rubber tires, and a good differential is about \$500, and when finished the steel wheels will not burst and kill people by going in the ditch. Soon as I get my auto finished, in May, I will run it to New York on purpose for you to inspect. Fifty men interested in automobiles have called to see my auto in its construction and all speak well of it.

Oneonta, N. Y.

M. W. HAZELTON.

### "PATHFINDER'S" AVOIDANCE OF JERSEY.

Editor THE AUTOMOBILE:

[1,341.]—It is with much pleasure that I read "Pathfinder's" description of his New York-Philadelphia trip in the April 23 issue of "The Automobile," as I have greatly enjoyed the same route for many years past—both by bicycle and White Steamer—and can highly recommend this route for beauty and pleasure. Some variations can be made, and a better stopping place for the night cannot be found than Peters' Hotel at Bushkill. The drive through the "Gap" is most beautiful and enjoyable, and is just as fascinating to me as it was twenty-five years ago.

From Portland, an easier route is by way of Nazareth, Bethlehem, and via the Bethlehem pike to Chestnut Hill, Philadelphia, to Pelham, and through Fairmount Park to the center of the city. As this is an easy two days' trip, I would advise turning around after passing through the "Gap" and back to the center of the village, then turn left through the beautiful Cherry Valley to Saylorburg, Wind Gap, and Nazareth, and as above to the city.

Tourists from New York for Wilkes-Barre and Scranton can avoid "Jersey justice" by "Pathfinder's" route to the Water Gap and Stroudsburg—or Bushkill to Stroudsburg direct—then to Bartonsville, and over the beautiful Pocono Mountains to Pocono Summit; left through Stoddardsville to Wilkesbarre, or right through Elmhurst and the Boulevard to Scranton. GEORGE E. FLING.  
Germantown, Philadelphia.



Hiram Percy Maxim in His Latest Electric Creation.

**S**IMPLICITY and compactness distinguish the new Maxim and Goodridge electric, of which the first representative forms the leading illustration on this page. It has been a matter of common knowledge, ever since Hiram Percy Maxim resigned as chief engineer of the now defunct Electric Vehicle Company, last summer, that he and T. W. Goodridge were working on the design of a new electric for which some new features were promised. That the promises have been fulfilled is evident upon a review of the specifications of the power plant of the new car, which marks a decided departure from conventional practice in this respect. In place of the customary gear, or sprocket and chain drive, a worm has been substituted, this form

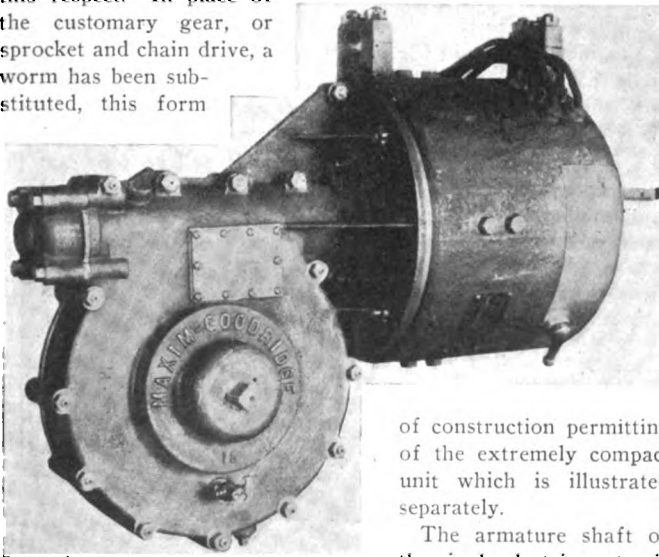

The Novel Driving Unit.

directly upon it, a vertically divided housing, independent of that of the motor, serving to carry an outboard bearing to support the prolonged end of the driving shaft. This housing is bolted directly to the end of the motor, and the stub ends of the differential shafts project through it, as will be seen in the illustration. It will be apparent that this drive is not only the acme of simplicity, but it accomplishes the necessary drop in speed between the motor and the driving axles by means of a single reduction, a gear ratio of 10 to 1 being employed. In addition to this, it permits of the motor and its drive being made in the form of a

of construction permitting of the extremely compact unit which is illustrated separately.

The armature shaft of the single electric motor is extended several inches and the worm is mounted

much better and permitting of the use of solid rubber tires. The springs are unusually long, which, together with the fact that the entire load is carried by them, is said to make the car as comfortable as the ordinary type equipped with pneumatics. In order to equally distribute the weight, the complete battery is carried forward under a bonnet. It consists of 30 cells of 11 PV Exide, and by means of the arrangement mentioned the weight is so evenly distributed that the new Maxim-Goodridge electric car, with two passengers up, has only 35 pounds more weight on the rear axle than on the forward one. This has an important bearing on the ease of riding and is likewise a material factor in the tire problem.

Another original feature is to be found in the control, the handle being mounted on the steering post just below the steering lever, making it more convenient to operate, besides saving seat room as compared with the usual style, for which it is necessary to sacrifice part of the cushion. The motor is of General Electric make, and by means of a special type, uninterrupted torque, multiple-series controller, five speeds ahead and three reverse, are provided, the maximum forward speed being 18 miles per hour. Fifty miles is about the maximum on a single charge of the batteries, with either pneumatic or solid tires, on ordinary roads, with an increase over this figure on good city pavements. With the battery equipment already mentioned, the weight of the car is 2,100 pounds, being correspondingly less with a smaller battery and simpler type of body. The chassis is entirely self-contained and any type of body desired may be supplied, although the standard is the Victoria-phaeton shown in the illustration. Complete with this equipment the car lists at \$1,800.

Two sets of brakes

single and practically self-contained unit, thus avoiding the necessity of employing the numerous other small parts essential to the customary form of drive.

The mounting of the combined power plant and drive is equally original, this unit being supported from the chassis frame, and being so placed that the differential stubs already referred to stand in approximate alignment with the centers of the rear wheel hubs. The differential is connected to the driving wheels through the medium of two shafts provided with universals, the design being such that these shafts lie in approximately the same plane when the car is carrying its normal load, the joints taking care of inequalities in the road. The axle is offset to allow for the clearance of the universal joints, and, except for this feature, is of the conventional floating design, the rear wheel hubs engaging driving dogs on the ends of the axle shafts.

The entire weight of both the car and its power-plant is thus carried on the springs instead of being "dead" on the rear axle, making the riding of the car



Showing Position of Power Plant.



are provided, one set operating on the drums placed on the driving wheels and the other on the motor shaft, both being pedal operated. An unusually long wheelbase is provided for this type of car—namely, 84 inches—while the running gear consists of 32 by 3 1-2-inch artillery wheels, these two points in the design of the car adding greatly to its ease of riding.

High frictional losses and the fact that, as ordinarily designed, the worm and pinion comprise an irreversible driving set, have militated against its adoption in the past. The problem has been one largely of tooth angle and tooth area, and that is has been successfully solved is evident from the use of the worm on a

number of gasoline cars for the past three years, notably heavy passenger 'buses in London. In the present instance, the designers claim to have greatly improved on anything thus far done in this line, and while the manner in which they have accomplished this is not to be made public, the extremely small frictional losses are evident from the fact that the car can be moved by the slightest effort, while tests of power consumption give positive proof of the low point to which the losses have been reduced. The worm is made of specially hardened steel, both the worm shaft and the motor armature shaft running on D. W. F. ball bearings, the whole unit being tightly housed.

## MACHINING AUTOMOBILE CRANKSHAFT BRASSES

SOME time ago a correspondent showed a set of jigs and fixtures for machining automobile crankshaft and connecting-rod brasses. As we do very large quantities of these, I can speak with some authority on this subject, says R. Roton, in the *American Machinist*. Some tools make them in good time, but

for assembling, it is extremely annoying to find that they will not match or that they are not interchangeable.

This means trouble and also expense, so we designed the tackle shown, which gets over the difficulty, and has saved its cost many times over, as all the brasses bored and turned on it are absolutely interchangeable, the joint being dead central every time. *A* is a gray-iron face plate for the capstan lathe; *B* is a lug milled on the top edges as shown, across the center, on which the milled half bushes are laid. *C* is a rib for supporting *B*; *D* is a boss for carrying the screwed pin *F*. *E* is a similar boss to *D*, for supporting *J*, which carries the swinging eyebolt *I*. *G* is a small cotter pin passing through *F* to keep the swinging clamp *H* in position, which is tightened down by *K*, operating on *I* through a slot in the end of *H*. *X* shows the half brass bush in position for boring and turning the front collar on the fixture. After it is bored and the front collar faced and turned, it is turned round and a hardened, ground, locating mandrel fits in the hollow spindle, on to which the half bush is clamped, as before. The back is then turned and faced, the end fitting tight up against the machined face plate; the front end is turned and faced to length, the diameter of the two collars being exactly the same.

The bushes are then taken to the engine lathe and turned on the mandrel shown in Fig. 3, which is hardened and ground. *L* is the part where the driver is clamped on; *M* is a collar solid with the shaft, a section of which is shown at Fig. 4. *N* is a similar loose collar; *O* is the nut for securing the lot. *X* shows a dotted bush in position for turning. It will be seen that the recessed insides of the two collars *M* and *N* grip the collared ends of the bushes and close them on the mandrel, which should be a good fit on the body. The tighter the nut *O* is gripped, the more the bushes are closed on the mandrel, and thus held true in position for turning the body or middle part. Brasses done by this method save a lot of time in assembling, and the operation of sweating the two halves together is entirely obviated, which is a very desirable feature, as when the soft solder is in the joints it opens them 0.005 to 0.010 inch and has to be scraped out afterward by hand to get them to a true circle.

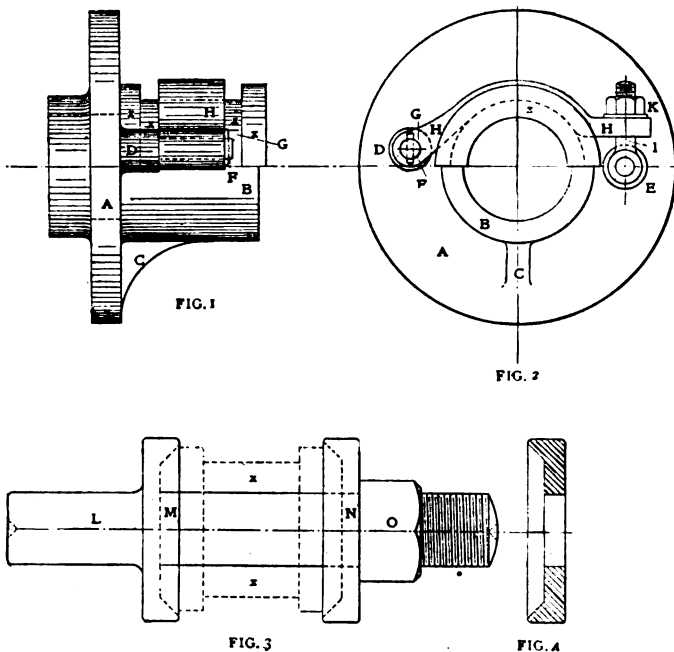

in the boring and turning of the brasses the two halves for making a complete bearing are not always equal. This is due to the method of setting the brasses for boring, the process being first to sweat the two halves together, then file a small groove across the joint, and locate it centrally by two pointed screws on the face plate for that purpose. When the brasses are taken apart

## IN EXPLANATION OF CARBURETER BACK-FIRING

OF all the carbureter troubles that have mystified the novices of each succeeding season, probably there is none that has proved so utterly puzzling, as well as alarming, as that of popping or back-firing, says *The Motorist*. This mysterious ailment has a habit of appearing with an irregularity that is disconcerting, and which makes it appear as if it were not the outcome of any particular combination of circumstances, as would be the case were its presence only an accompaniment of certain visible and easily-detected symptoms. But it comes and goes unexpectedly, at times reaching proportions that are alarming, particularly when flames shoot out of the air inlet of the carbureter—an occurrence

which gives the average driver visions of a conflagration and the smoking ruins of his car. It is difficult for him to understand why this fire should not ignite either the gasoline or the vapor itself that is in the carbureter at the time, and send the whole car up in flames. Simply because the former does not ignite readily, due to the fact that it is almost pure vapor with little or no air, and the flame passes over the latter at such a speed that it has not time to take fire. Even though the spray issuing from the jet should take fire, the flame could not travel back through the spray nozzle to the float chamber, and it would be extinguished by the next inrush of air immediately following.

## RENTING AND COST ACCOUNTING CONSIDERED

By LORENZO B. BAKER.

**T**OTAL profit of all departments of a business cannot be greater than the sum total of the profit of each department. Hence, it is just as important to know the result in each department as to know the result as a whole, for an unsuspected loss in one department may be overcome and hidden by the profit in another. Any condition thus hidden is as dangerous to a business as a hidden bomb is to unpopular royalty. The dealer who has such spots in his business will in the last analysis always lose out to his competitor who has none.

Native shrewdness is not a match for just common every-day judgment, when the latter is based on facts regarding detail, which the former is apt to ignore. Manifest advantages of location, capital, and shrewdness cannot, in the long run, hold their own against analyzed facts well digested.

It is not my purpose to introduce a lot of figures to show the cost of operating cars, or to illustrate the possible profit or loss that may result. Let us first determine whether or not it is worth while to inquire into the matter and to so shape the accounting as to show it.

How many can tell whether or not they make a profit from the rental on cars? Of those who think they make a profit on rentals, how many can tell *how much* they make on this department of their business? Few, indeed, are those who can give a reasonably satisfactory answer to the latter question.

What reason is there for renting cars unless you are thereby able to make a profit that could not be made in any one or all of the other departments of the business?

When a department is here spoken of, it is not necessary to suppose that it implies a number of men and their foreman. Instead, it is the designation of an element in the analysis of business. If one man does all of the work, he may be considered the repair department at one time during the day, and the office force at another. Manifestly, it is not fair to penalize one department for the advantage of another; therefore, if the repair department makes repairs on a rental car, these repairs should be charged for at not less than cost. Of what, then, does this cost consist? Certainly of the value of materials and parts used, and of labor. But is this all? If the dealer was to charge other customers on this basis, he would soon go out of business, because the real cost consists not only of material and labor, but also of rent, depreciation, general expense, etc.

If, then, a method could be determined that would correctly apportion to the repair department, its share of all overhead expense, would the resulting charge to the rented auto for the cost of repair, consisting of material, labor and overhead, be the correct charge for the repair? We find at this point that there are two methods possible, and that either will give results, and the intimate knowledge that it has been contended is necessary.

If costs were thus transferred from repair department to the rental department, there would not result any hidden losses, and the entire expenditure for repairs would be known. There is a reason, however, for saying that by stopping at this point in our costs, we have allowed the rental department to show a profit that, in part, belonged to the repair department.

Is not the repair department entitled to the same profit on its work for the rented car, as on work for outside parties? Is there any reason why a profit should not be made on cars rented above the amount that repairs would cost, if purchased outside?

The rental department may rightly be considered as a business by itself, and, when so considered, it is entitled to a profit on the rental element alone, presupposing that all accessories, gasoline, repairs, etc., are bought in the open market, and that on them there has been made a reasonable profit. Why should the auto renter cheat himself of one profit? He is entitled to two profits—one on repairs, supplies or accessories as a dealer, and the other as a renter of cars. He may consider himself as a liveryman, who buys his carriage horses, feed and repairs. A liveryman does not run either a wagon shop that he may repair his buggies, or a harness shop to repair his harness, or a farm to raise his feed, and he expects to make a profit after paying some one else a profit on these articles.

There are several other elements of importance that enter into the cost of the rental of cars that cannot be considered in detail here. Managers may ask if it would not be necessary to employ a high-priced bookkeeper to secure the kind of accounting here advocated.

We find in all departments of industry that results seemingly complicated are attained by simple means, because of the thought that has prepared a way that any person of average ability may easily follow. So it is as regards the accounting that is necessary to properly exhibit these costs. It does not involve more skill than is possessed by an average bookkeeper.



How Henry Ford Utilizes an Automobile Plow of His Own Design on His Farm Near Detroit.

Mr. Ford predicts that the next ten years will see automobiles in use doing work of so varied a kind that, even with all our knowledge and our preparedness to accept almost any advance, we dare not anticipate, and that one of the sure developments will be in the way of self-propelled farm implements.

# THE AUTOMOBILE

Vol. XVIII

Thursday, April 30, 1908

No. 18

## THE CLASS JOURNAL COMPANY

Flatiron Building, Madison Square  
New York City

H. M. SWETLAND, President

### EDITORIAL DEPARTMENT

A. G. BATCHELDER, Managing Editor  
R. F. KELSEY, Associate Editor C. B. HAYWARD, Engineering Editor  
W. F. BRADLEY

### BUSINESS DEPARTMENT

A. B. SWETLAND, Business Manager  
LOUIS R. SMITH FRANK B. BARNETT  
W. I. RALPH, 1035 Old South Building, Boston, Mass.  
C. H. GURNETT, H. E. WESTERDALE, 1200 Michigan Ave., Chicago, Ill.

Cable Address - - - - - Autoland, New York  
Long Distance Telephone - - - - - 300 Gramercy, New York

### SUBSCRIPTION RATES:

United States and Mexico - - - - - One Year, \$3.00  
Other Countries in Postal Union, including Canada - - - - - One Year, 5.00  
To Subscribers—Do not send money by ordinary mail. Remit by Draft,  
Post-Office or Express Money Order, or Register your letter.

### FOREIGN SUBSCRIPTION AGENTS:

ENGLAND:—Hilffe & Sons, Limited, 29 Tudor Street, London, E. C.  
FRANCE:—Boyveau & Chevillet, 22 Rue de la Banque, Paris.  
GERMANY:—A. Seydel, Mohrenstrasse 9, Berlin.

Entered at New York, N. Y., as second-class matter.  
The Automobile is a consolidation of The Automobile (monthly) and the Motor  
Review (weekly), May, 1902, Dealer and Repairman (monthly), October, 1903,  
and the Automobile Magazine (monthly), July, 1907.

Copies printed in 1905	- - - - -	730,000
" " in 1906	- - - - -	791,000
" " in 1907	- - - - -	888,900

### DEDUCTIONS FROM THE BRIARCLIFF RACE.

Among the features that characterized the running of the race for the Briarcliff trophy over a course that was concededly impossible, none stand out with more prominence than the remarkable uniformity with which such a very large proportion of the contestants continued to reel off lap after lap, and the positively marvelous manner in which tires endured strains of a severity far beyond what they had ever been called upon to meet in any road racing event up to the present. Figuring by precedent, and adding a generous percentage to allow for the vast difference in the nature of the course, as compared with that on which the Vanderbilt race has been run, it was confidently predicted that half of the contestants would see their chances ruined in the first lap. The succeeding lap or two were counted upon to be equally effective in eliminating probably as many more of those that remained, while it was scarcely thought possible that there would be more than a handful still running when the yellow flag should bring the race to its official end.

The actual results show how very far wrong were all these predictions. The dolorous head-shakings of the wise ones as to the frequency with which tires would have to be changed, and the numerous prophecies, based on experience, regarding the wide swath one or two laps of that course would cut in the ranks of the competing cars, all went for naught, as did equally the somber forecasts of those who thought that the services of the ambulance would be in great demand. The regularity with

which the cars ran and the manner in which their tires stood the terrific strain, are matters that can be explained by the simple word improvement; but that none of the spectators were killed is one of those profound mysteries that only the quotation of such proverbs as "There is a special Providence that looks after, etc.," can serve to throw any light on. The nature of the country, however, forced people off the road and up the bank to gain points of vantage, and thousands were forced to places of safety.

Taken all in all, the Briarcliff trophy race was a successful event of its kind, but if stock touring car races are to form a permanent feature of automobile racing, as it seems very probable they will, they should not belie their name as this one did. Just what a stock car is will have to be defined much more closely. The maker who turns out a limited number of a specially fast type of car to order is justified in calling it a stock car, as it complies with the requirement that he shall have built not less than ten duplicates of it, but it places him in a vastly superior position to the entrant who lists a type of car designed for the needs of the many, and of which he is turning out hundreds, or thousands, annually. In a race where speed alone is the consideration, no fault can be found with whatever type of car is employed to attain that end, but where the principal object is to display the staying qualities, combined with speed, of the type of car that the average autoist wishes to own, it is surely a travesty to permit the palm to be carried off by representatives of a speed model, destined to be produced in very limited numbers. In last week's race, this applied quite as much to some of those that did not win, as to those that figured prominently in the honors.

All the entrants must be placed on an equality as far as possible, and to achieve this there must be a more effective means of defining exactly what a stock car is. It is all very well to limit its piston displacement, thus barring very high-powered cars, but the stock car, to fulfill the requirements of its title, must be the generally salable product of its maker, and not the special speed design turned out to meet the wants of a very few. That more than ten duplicates of the car entered should have been turned out would be necessary, and it would also be well to so alter the rules as to make the committee the arbiter of this point. Why should not the committee actually choose the car at the factory?



### ENGINEERING DATA ON THE AUTOMOBILE.

Mechanical engineering was a pretty staid and settled science long before anyone thought it worth while to attempt to preserve data on its multitudinous features, but, then, progress was not over rapid a century or more ago. Despite the vast volume of valuable data that has been compiled in the last fifty years or so, there is a large part of it that is not applicable to automobile engineering. A great deal of matter well worthy of preservation, and of value to automobile builders, has been written in the past seven or eight years, and, as automobile engineering is a very new branch of the science that represents a radical departure from standards current in other lines, much inconvenience has resulted from inability to find this data. It is a matter for congratulation, therefore, that a well-known designer has undertaken the compilation of an automobile engineer's handbook.

### NEW YORK'S BILL AT SPECIAL SESSION.

ALBANY, N. Y., April 26.—The Armstrong-Merritt automobile bill may be taken up at the special session of the Legislature, called by Governor Hughes for next month. It will be remembered that Senator Armstrong moved on the day before adjournment to recommit the measure to the committee, stating that it required essential though slight revision before final passage. In the bill as first introduced the annual registration fees ran from \$3 to \$13, these being the figures proposed by Oliver A. Quayle, president of the New York State Automobile Association. Subsequently A. R. Shattuck, a New York City automobilist, assuming to represent the A. C. A., was responsible for increasing the fees from \$5 to about \$40 for the highest powered cars. Later, at a final conference concerning the measure, W. W. Niles, attorney for the A. C. A., supported Senator Armstrong in insisting upon a jail penalty for a first offense, which proposition was opposed by President Quayle, of the State association, and President W. H. Hotchkiss, of the A. A. A. While it is true that all speed limits are eliminated, not a few automobilists are questioning whether the vastly increased fees and the jail clause are a commensurate exchange for the abolition of speed traps.

#### Governor Hughes Will Recommend that It Be Included.

ALBANY, N. Y., April 29.—Senator Jotham P. Allds had a conference with Governor Hughes yesterday afternoon and found the Governor favorably disposed to recommending to the extraordinary session of the Legislature the Armstrong-Merritt Motor Vehicle bill. The Governor was informed how the Senators and Assemblymen in charge of the bill—Armstrong, Allds and Merritt—were busy up to the last moment of the session, so that they had no time to perfect the bill in several particulars and get it amended in time to pass it even with the aid of an emergency message. The Governor appreciates, as do the legislators, that the State will lose for another year nearly half a million dollars if this proposed new scheme of registration or taxation of motor vehicles is not enacted into law.

### VAN SICKLEN RESIGNS; GORHAM SUCCEEDS.

CHICAGO, April 27.—N. H. Van Sicklen, who has served as secretary of the Chicago Automobile Club since last fall, has resigned because of contemplated absence from the city. 'Tis said "Van" will try the quiet life of a farmer at St. Charles, Ill. To fill his unexpired term Sidney S. Gorham, who was secretary of the organization for four terms, has been selected by the board of managers. Mr. Van Sicklen's resignation was accepted with considerable regret, as he has long been an active favor in the affairs of the club. He has also resigned as chairman of the technical board of the American Automobile Association.

### THEATRICAL TAXICABS FOR NEW YORK CITY.

Further details of the enterprise which will maintain a special theatre service of taxicabs are now forthcoming. The Front Drive Motor Car Company is the name of the concern which has been incorporated with a capital of \$250,000. W. Gould Brokaw and Morris Gest, of the theatrical firm of Comstock & Gest, are the backers, and it is said that theatrical firms have already subscribed for stock. Walter Christie is the designer of the car, which will be of the front-drive type, the entire power plant and transmission being in self-contained unit form and readily detachable. A twelve-story building, now in course of construction, constitutes the main station.

### LONG ISLAND STRAIGHTAWAY RACES, JUNE 5.

Under the auspices of the Long Island Automobile Club, arrangements are being perfected for the holding of straightaway races on Hillside avenue, just outside of Jamaica, L. I., the day and date being Friday, June 5, and the affair being a part of the celebration of the opening of the Long Island subways. A. R. Pardington is to be the general manager, and the course is to be police guarded. Hillside avenue will supply a model course.

### THE 1908 VANDERBILT CUP COURSE?

Whether the Vanderbilt Cup course for 1908 will be located in Georgia or Connecticut yet remains to be definitely decided, with indications at present favoring Savannah. A definite announcement is expected in the near future. Harvey W. Granger and Secretary A. W. Solomon, of the Savannah Automobile Club, have been in the city this week, conferring with Chairman Jefferson deMont Thompson and other members of the A. A. A. Racing Board, who are also of the Cup Commission.

### OSBORNE I. YELLOTT'S UNLUCKY REPAIRING.

BALTIMORE, April 27.—Osborne I. Yellott, counsel for the Automobile Club of Maryland, was burned about the face and hands while repairing his automobile. He was lying on his back under the machine when the vapor, from oil which dripped on Mr. Yellott's face and hands from a broken gasoline pipe, spread to a lamp which exploded. Farm hands smothered the flames with horse blankets. It may be necessary to call upon friends to furnish cuticle for grafting skin over the burns on Mr. Yellott's face and hands.

### A. M. C. M. A. SHOW OPENS NEW YEAR'S EVE.

New Year's Eve, a great gala night in New York, has been finally chosen for the opening of the show of the American Motor Car Manufacturers' Association, at Grand Central Palace. It will continue for eight days, thus making the show dates December 31, 1908, to January 7, 1909.

In choosing the opening week of the year, the promoters believe the date chosen will prove an ideal one from the fact that during the first week of the year something like 150 big railroad and industrial corporations pay out from New York almost \$200,000,000 in dividends on stocks, without reference to bonds, mortgages and other securities. Much of this money each year has gone into the purchase of automobiles.

### GLIDDEN PATHFINDERS START THIS WEEK.

BUFFALO, April 28.—Dai Lewis, secretary of the A. A. A. Touring Board, plans to start Friday morning to lay out the route for the annual national reliability test. He will be accompanied by an assistant and a photographer. Every mile of the road will be measured and notes and photographs for the guide book of the tour taken. The pathfinding trip will be made in a Premier, which, by the way, will also serve as a confetti car on the tour itself. The Premier, it will be remembered, was the only four-cylinder car selling under \$3,500 competing for the Glidden trophy which evolved last year with a perfect score. Leon Myron Bradley, of the A. M. C. M. A. staff, will accompany Secretary Lewis as representative of the Premier Motor Car Company.

### JUDGE GARY NAMES HIS COMMITTEEMEN.

Judge E. H. Gary, the new president of the Automobile Club of America, has announced his standing committees for the year so far as they have been determined upon by him. In many cases only the chairman has been named, the selection of their associates not yet having been completed. The most important committee of all is the executive committee, which will practically have charge of the affairs and the actual running of the club itself. Henry Sanderson, the first vice-president, is chairman of this committee, which also contains Dave H. Morris, Colgate Hoyt and Edgar L. Marston.

Chairmen of the most prominent committees are as follows: Good roads, A. R. Shattuck; entertainment, Orrel A. Parker; bureau of tours, Waldron Williams; contests, Robert Lee Morrell; racing, Samuel B. Stevens; technical, Dr. S. S. Wheeler; laws and ordinances, Phillip T. Dodge; city streets, W. W. Niles; foreign relations, John E. Bourne; public safety, George F. Chamberlin.



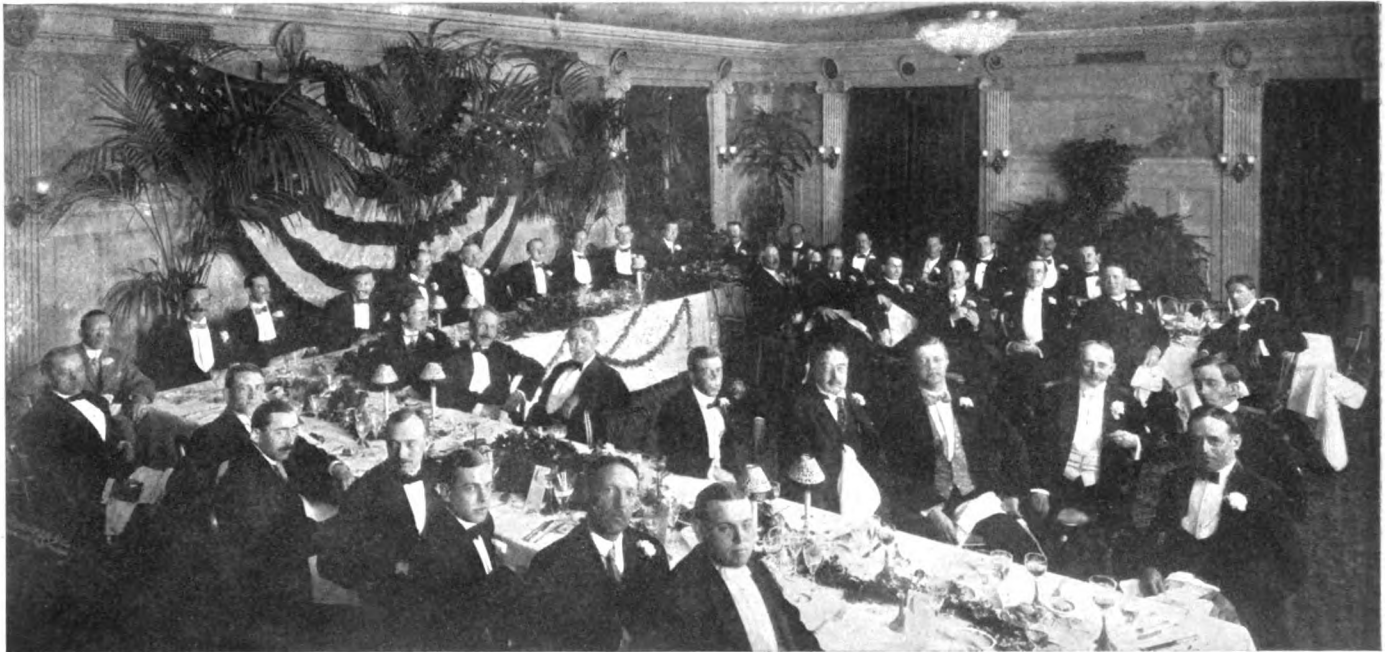

Around the Festive Board at the Hotel Astor Were Many Well-known Autolists In and Out of the Trade.

### "WAG" GETS A BANQUET AND A STOP WATCH.

NEW YORK, April 27.—It is no exaggeration to say that "Wag" was given "the time of his life" at the Hotel Astor on Sunday night, when a few of his intimate friends to the number of forty-six gave him a banquet and a very useful souvenir of their affection. Though the affair was hastily gotten up, there was a ready response to the invitations, few hesitating either at Sabbath breaking or even leaving suburban homes on a Sunday night to participate in jolly along such a popular veteran of both bicycling and automobiling as this same Fred J. Wagner. In the gathering were men prominent in the sport and industry and not a few veterans of the old bicycle days gone by, all now, however, included in the automobile fold. Those who could not be present sent letters, and there were telegrams, too, from distant points.

E. E. Schwarzkopf, "Wag's" proverbial pinochle partner, starting the game of jolly that was played with humor and sincerity the whole evening, and concluded by the presentation of a gold stop watch. "Wag" proved he had sentiment and not a little poetry in his composition by his "come back." Robert Lee Morrell was then installed as toastmaster, and he saw to it that as many of the post-prandial orators as possible within the midnight limit got a chance to get rid of what was on their minds. All had stories to tell of "Wag," and all handed it to him good and plenty. Some even sprung poetry on the old man, and R. H. Johnston went so far as to immortalize him in a song with a chorus that all quickly learned and sang with a will.

Among those who got rid of the jollies and the reminiscences that were on their minds before the lid was put on were: A. R. Pardington, Charles Jerome Edwards, George W. Bennett, Benjamin Briscoe, E. R. Hollander, Alfred Reeves, E. S. Partridge, Henry Caldwell, Guy Vaughan, Joseph W. Gilbert, R. A. Field, A. G. Batchelder, John C. Wetmore, Thomas Francis Moore, R. B. Johnston and Nathan Lazarnick. Others of "Wag's" friends present were: Arthur N. Jervis, H. T. Clinton, Thomas Wetzell, J. S. Draper, L. D. Rockwell, W. J. Morgan, A. J. Picard, S. W. Merrihew, A. L. Kull, A. B. Tucker, W. W. Burke, Cortlandt Cramp, Duncan Curry, Harry Fosdick, C. F. Wyckoff, A. W. Church, Frank Crane, A. L. McMurtry, Alexander Dow and John Williams. Telegrams were read from W. E. Metzger, Louis R. Smith, E. LeRoy Pelletier and others.

The college room of the Hotel Astor was most artistically decorated, flags and flowers being utilized generously in making the cozy banquet room decidedly inviting. It was well after midnight before the festivities concluded.

### CONNECTICUT ACQUIRES BASIC COIL PATENT.

By the purchase of United States patent No. 884,116, issued to E. Q. Williams, of Syracuse, N. Y., on April 7 last, the Connecticut Telephone and Electric Company, Meriden, Conn., has acquired exclusive rights to the manufacture and sale of the multiple unit type of induction coil now universally used on automobiles. Mr. Williams was the unquestioned originator of the removable unit multiple coil, as shown by the fact that his application for a patent dates back to December 28, 1904, the delay in finally issuing a patent being due to the fact that it was involved in an interference with the claims of Richard Varley on the same form of construction. A final judgment of priority of invention having been granted to Mr. Williams, together with the very early filing date of his application, gives his patent precedence over all others filed and issued subsequently to 1904.

The patent in question contains no less than 57 separate claims, fully covering the now general removable unit construction, single and duplex battery switches on the coil containing case, and similar features. After carefully investigating Mr. Williams' claims and thoroughly establishing his priority in the art, the Connecticut company immediately acquired the patent and all rights thereunder. The Connecticut coils will be made under this patent, in addition to retaining the numerous features which have distinguished them in the past, while Mr. Williams will continue to manufacture the coils as previously, under an agreement with the new owners of the patent. The Connecticut company holds numerous patents, both issued and pending, on the special features of its coils, and will undertake a vigorous campaign against infringers. The outcome of this new development of the patent situation will be looked forward to with interest, basic patents having cropped up, from time to time, on the majority of the principal features of automobile construction and accessories.

### HEAVY REGISTRATION IN PENNSYLVANIA.

PHILADELPHIA, April 27.—Figures recently issued by the Highway Department of Pennsylvania show that during the months of January, February and March there were issued by the authorities at Harrisburg no less than 14,500 licenses to operate motor vehicles in the State. These, at \$3 each, will provide much more than the amount necessary to run the department, and with three-fourths of the year yet to hear from, it is reasonable to presume that the total registrations will easily pass the 20,000 mark. Last year's total was about 1,500 short of that figure.

## ACTIVITIES IN AUTO CLUBDOM'S REALM

### BURLINGTON CLUB TAKES NEW LEASE OF LIFE.

BURLINGTON, VT., April 27.—Last Tuesday evening, the Burlington Automobile Club held one of the most enthusiastic meetings in its history. A large number of new members were admitted, and W. A. Suydam was elected as corresponding secretary. Three new standing committees were appointed, as follows: Legislation, A. C. Whiting, A. G. Whittemore, J. S. Patrick; good roads, Capt. E. P. Woodbury, B. L. Kent, F. L. North; by-laws, W. A. Suydam, C. L. Woodbury, G. A. Churchill. President Hawley spoke strongly in favor of better roads and regulations to govern same, and in favor of enforcing the law to require selectmen to provide sign boards at all turns and cross-roads in the townships. The proposition of holding a parade and banquet on Decoration Day was left to the executive officers of the club to decide upon. The club will tender the use of the members' autos to disabled war veterans on that day, to convey them to the grave decorating ceremonies at the cemeteries.

### FULLER RE-ELECTED PRESIDENT NUTMEGGERS.

NEW HAVEN, CONN., April 27.—At the annual meeting of the Connecticut Automobile Association, held in this city last Wednesday evening, W. F. Fuller, president of the Automobile Club of Hartford, was re-elected president, and Secretary G. K. Dustin was again chosen as secretary. Dr. Hertzber, of Stamford, was chosen as treasurer. The Willimantic Automobile Club, recently organized, was admitted to membership.

Plans were formulated for greatly extending the usefulness of the State association, and Secretary Dustin was authorized to pay official visits to towns in the State where the automobile interests warrant the formation of local clubs, with the view of rendering all the assistance possible. The next meeting of the State association will be held at Bridgeport, May 30.

### GRAND RAPIDS CLUB ELECTS NEW OFFICERS.

GRAND RAPIDS, MICH., April 27.—The Grand Rapids Auto Club has held its election of officers, which resulted as follows: D. Emmett Welsh, formerly treasurer, and also secretary of the State association, was elected president, and J. R. Jackson, member of the touring board, A. A. A., and treasurer of the State association, was elected vice-president. Dr. William Burleson was made secretary, and Lewis C. Parmenter, treasurer; board of governors, A. A. Barber, George W. Hart, and W. D. Vandecar.

There is a possibility that the club will abandon its Cascade clubhouse, about eight miles southeast of the city, and decide on a clubhouse north of the city, on Grand river, near Plainfield.

### ENTRY BLANKS FOR SPORT HILL CLIMB READY.

BRIDGEPORT, CONN., April 27.—With the advent of "good going," the Automobile Club of Bridgeport is exhibiting an enthusiastic activity. Entry blanks have been issued for the annual hill-climb at Sport Hill on Memorial Day, May 30, and the lists are filling up rapidly for that event. Nine classes for cars ranging in price from \$850 to \$4,000 and over, and including a free-for-all, and the Cranford Cup for amateur drivers is on the program. It is expected the course will be patrolled by the Fourth Company, Coast Artillery, Connecticut National Guard, in command of Capt. George E. Hawes.

At the recent annual meeting of the club, the following officers were named for the ensuing year: President, Frank T. Staples; vice-president, F. A. Strong; secretary, F. W. Bolande; treasurer, L. B. Powe. Silas Burton, Ralph M. Sperry, and A. K. L. Watson were named as governors. Under an amendment to the constitution, the board of governors was increased by six members. The following were elected: De Ver H. Warner, Charles B. Read, Dr. H. S. Miles, J. B. Lyford, F. A. Rantz, and J. T. Fray.

State Highway Commissioner James H. Macdonald addressed the meeting in an interesting talk on the subject of State roads, and the relation of the automobile to the maintenance of good roads. Mr. Macdonald was elected an honorary member of the club. The club is about to adopt new colors. A committee is now at work deciding upon a simple and effective banner, which will be introduced this season.

### TEST RUN AT WILMINGTON, DEL., MAY 17.

WILMINGTON, DEL., April 23.—Wilmington will have its first actual automobile run on May 17, when there will be an ability run under the auspices of the Delaware Automobile Association. It will be over a 45-mile course, which will include Avondale, Kennett Square and Westchester, Pa. The cars will run under sealed orders, so that each will not know what handicap has been allowed, the object being to give all cars, regardless of power, an equal chance. The association has placed the entrance fee of its members at \$2 each, and for non-members at \$5. Valuable prizes will be given to the winners.

### INDIANA CLUB TO HAVE ROAD RACE.

INDIANAPOLIS, IND., April 27.—The Indiana Automobile Club, the strongest organization of its kind in the State, is preparing a program of road races for July 4. While the club is opposed to track racing, it believes that a good program of road races would be interesting. The course contemplated is only four miles long, starting at the Thirtieth street entrance of Riverside Park, thence west up the hill at the west side of the park to the



Referee R. H. Johnston, of White Steamer Pathfinder Fame, and His Associate Harrisburg Run Path-Layers.

first roadway running south, from where there will be a straight run to Emrichsville, returning over the Riverside Boulevard. About half of the course is in view of the park, and it is proposed to erect a grandstand, the proceeds from which would likely pay the expenses of the races.

Drivers of note from all parts of the country are expected to enter, and C. G. Fisher has offered to donate a \$500 cup. It is proposed to begin racing at 5 o'clock in the morning, and to employ 150 special policemen to keep the course clear.

#### WILLIAMSPORT HILL CLIMB TO BE HELD JUNE 6.

WILLIAMSPORT, PA., April 27.—Sanction for the second annual hill-climb of the Williamsport Automobile Club has been obtained from the A. A. A. racing board, and June 6 is officially announced as the date. There will be fourteen classes on the program, for which silver cups will be awarded, and the car making the fastest time of the day will be awarded a special cup valued at \$100.

The course is exactly one mile long, and the grade rises from 14 per cent. at the start to 11 1-2 per cent. at the finish. The rise is 407 feet, and the road is of boulevard construction. By reason of the smoothness of the road and the fact of the few curves in it, there is every expectation that the world's record for a mile hill-climb may be broken. There were twenty-one cars in last year's race, and it is expected that the number will be largely increased this year.

#### SPRING AWAKENS RUBBER CITY AUTOISTS.

AKRON, O., April 27.—These sunny spring days have warmed the members of the Akron Automobile Club into life and a resolve to reorganize the club, which of late has rather drifted into innocuous disquietude. A meeting for this purpose is soon to be called. A year ago there were less than 300 owners in this city, but now there are over 400, and the necessity of an active club is felt. The first run of the Cleveland Automobile Club will be to the lakes, south of Akron, and will bring a big crowd of Cleveland autoists and machines.

#### TROJANS FORM AN AUTOMOBILE CLUB.

TROY, N. Y., April 27.—The Automobile Club of Troy has effected a preliminary organization and chosen the following officers: President, Frank B. Twining; vice-president, E. S. Platt; secretary and treasurer, Alonzo McConihe. They and the following will make up the board of directors: G. A. Cluett, LeGrand C. Cramer, H. S. Ide, John McGlynn, J. J. Murphy, R. C. Reynolds, John Squires and Dr. L. R. Whitney.

#### AUTOMOBILE CLUB ORGANIZED AT MARIETTA, O.

MARIETTA, O., April 27.—At a meeting of automobilists of this city and vicinity, held last week, the Marietta Automobile Club was organized with the following officers: President, H. B. Coen; secretary, Joseph Baxter. There are some seventy owners of automobiles in Marietta, and it is hoped to interest all of these in the new organizations.

#### CLEVELAND CLUB WILL HAVE BUSY SEASON.

CLEVELAND, April 27.—The officers of the Cleveland Automobile Club are preparing for an active summer's work and are planning numerous club runs in addition to the hill climb and many minor events. The runs and tours committee of the club has drafted an excellent schedule for the season.

#### GLIDE CLUB PLANS RUNS FOR PEORIANS.

PEORIA, ILL., April 27.—The runs and tours committee of the Glide Automobile Club has arranged for a series of runs and has issued a schedule therefor, starting on May 1 and ending on September 26, some of them of two or three days' duration, embracing Sundays.

## THE AUTOMOBILE CALENDAR.

### AMERICAN.

#### Shows and Meetings.

- June 25-27.....—Detroit, Third Annual Summer Meeting of Society of Automobile Engineers.  
 January, 1909.....—New York City, Madison Square Garden, Ninth Annual National Show of the Association of Licensed Automobile Manufacturers. (Exact date to be announced.)  
 February, 1909.....—Chicago, Coliseum and First Regiment Armory, Eighth Annual National Exhibition, National Association of Automobile Manufacturers. (Exact date to be announced.)

#### Race Meets, Hill Climbs, Etc.

- May 4-5.....—Harrisburg-Philadelphia and Return, 300-mile Endurance Run, Motor Club of Harrisburg.  
 May 15.....—Chicago, Algonquin Hill Climb, Chicago Motor Club.  
 May 16.....—Hartford, Conn., 200-mile Endurance Run, Automobile Club of Hartford.  
 May 30.....—Bridgeport, Conn., Sport Hill Climb, Bridgeport Automobile Club.  
 May 30.....—Wilkes-Barre, Pa., Giant's Despair Hill Climb, Automobile Club of Wilkes-Barre.  
 May 30.....—San Francisco, Endurance Run under the auspices of the Automobile Dealers' Association.  
 June 6.....—Worcester, Mass., Dead Horse Hill Climb, Worcester Automobile Club.  
 June 24-27.....—Chicago, 1,200-mile Reliability Run, Chicago Motor Club.  
 July 7-8.....—Buffalo, N. Y., National Convention of the American Automobile Association.  
 July 9.....—Buffalo, N. Y., Start of the Fifth Annual A. A. A. Reliability Touring Contest.  
 Sept. 5-9.....—San Francisco-Los Angeles Reliability Run, under the auspices of the Automobile Dealers' Association of San Francisco.  
 Sept. 14.....—Chicago, Annual Economy Run, Chicago Motor Club.

### FOREIGN.

#### Shows.

- May 17-31.....—Austria, Budapest Automobile Show.  
 May 17-June 2.....—Moscow, Russia, International Automobile Exposition, Automobile Club of Moscow.  
 December.....—Paris, Eleventh Annual Salon de l'Automobile, Grand Palais, Automobile Club of France.

#### Race Meets, Hill Climbs, Etc.

- Apr. 25-May 25.....—Industrial Vehicle Competition, Automobile Club of France.  
 May.....—Paris, Competition for Agricultural Automobiles, auspices of "L'Auto." (Date to be announced.)  
 May 7.....—Selly, Palermo, Targa Florio Circuit, Voiturette Race, Automobile Club of Italy.  
 May 11-16.....—Ireland, Irish Reliability Trials.  
 May 1-31.....—Automobile Taxicab Competition, France, Automobile Club of France.  
 May 10.....—Selly, Targa Florio, Automobile Club of Italy.  
 May 31.....—Russia, St. Petersburg to Moscow Race.  
 June 1-18.....—Reliability Trials for Pleasure Cars, Automobile Club of Great Britain.  
 June 14.....—Mount Cenis Hill Climb, for Voiturettes.  
 June 9-17.....—Touring Competition for the Prince Henry of Prussia Prize, Germany, Imperial Automobile Club.  
 June 15-19.....—Scotland, Scottish Reliability Trials.  
 July 6.....—Voiturette Grand Prix, Dieppe Circuit (Automobile Club of France).  
 July 7.....—Grand Prix of Automobile Club of France, Dieppe Circuit.  
 July 13-17.....—Ostend, Belgium, International Race Week, Automobile Club of Ostend.  
 July 20-30.....—Ardennes Circuit Races and Coupe de Liedekerke, Automobile Club of Belgium.  
 Aug.....—France, Coupe de la Presse, Automobile Club of France. (Exact date to be announced.)  
 Aug. 29-30.....—France, Mont Ventoux Hill Climb, Vauclussen Automobile Club.  
 Sept. 1-8.....—French Voiturette Contest, auspices of "L'Auto."  
 Sept. 6.....—Bologne, Italy, Florio Cup Race, Automobile Club of Bologne.  
 Oct. 11.....—Berlin, Germany, Gordon Bennett Balloon Race, Aeronautical Club of Berlin.

**ANTHONY-HATCHER COMPANY ORGANIZED.**

GRAND RAPIDS, MICH., April 28.—A stock company, to be known as the Anthony-Hatcher Company, has just been formed in this city for the manufacture of automobiles, trucks, and parts. The automobile portion of the enterprise with which the company is now concerned is the exploitation of the Soule automobile delivery wagon, formerly located in this city, but which was removed to Kalamazoo some two years ago. It is stated that the business with this product has grown gradually but surely, and that the new company intends to forward its interests, again removing to this city and manufacturing. The company is capitalized at \$20,000. George E. Anthony and William A. Hatcher, who were engaged in winding up the affairs of the automobile department of the Harrison Wagon Works, are the principal stockholders.

**MEZGER GOES IN FOR WIND SHIELDS.**

Having made no little success in the manufacture of spark plugs and other ignition accessories, C. A. Mezger, Inc., 1759 Broadway, New York, has gone into the manufacture of windshields, having acquired the rights to the Conover automatic folding windshield, which was fully described in THE AUTOMOBILE of May 30, 1907. Mr. Mezger has renamed it the "Automatic," and it merits this title, due to its great simplicity, as there are no bolts or nuts

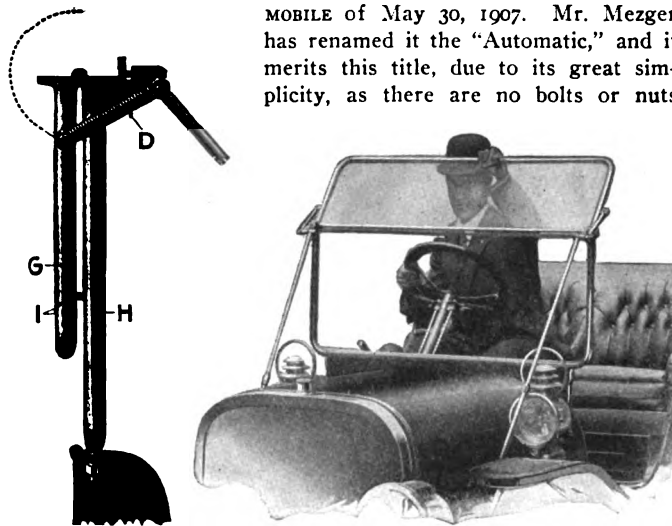

Details of the Mezger "Automatic" Windshield.

to be adjusted and it can readily be operated by the driver with one hand. The frame and fittings are entirely of brass and the latter are so constructed that it is entirely rattle-proof. The design and details of construction are fully covered by American and foreign patents. The National Sales Corporation, 296 Broadway, New York, are factory sales managers.

**THINGS DOING AMONG THE GARAGES.**

**New York City.**—A new garage is to be erected for the New York Taxicab Company, on Fifty-seventh street, between Eleventh and Twelfth avenues. It will be a four-story building of brick and concrete construction, and will contain the business office, repair shop, garage and storehouse of the company. It will be most completely equipped, and according to Harry N. Allen, president of the company, it will be ready for occupancy by September 1 next.

**Detroit.**—The new garage of the Westminster Auto Company, at 71-75 Mott avenue, has been completed and is now open. The company is backed by the same concern as the Broadway Auto Company, 36-40 John R street. C. S. Ross is in charge of the new establishment.

**Newark, N. J.**—Contracts have been placed for the construction of a two-story brick garage and dwelling at 401 Clinton avenue. The building is to be erected for William Bowdin and the first floor will be used for garage purposes.



The New Winton "Six-Teen-Six" at the Capital.

First and Second Secretaries of the Mexican Embassy at Washington, in a Winton "Six-Teen-Six," before the building housing the State, War and Navy Departments, and situated next to the White House.

**"MUDLARK" LOCATES IN OHIO'S TIRETOWN.**

AKRON, O., April 27.—Fred Work, who has made a number of memorable transcontinental and Southern trips, is having an Oldsmobile of special make manufactured. He has been at the factory of the company looking after the designs of the body in accordance with some of his special ideas. The "Mudlark," in which Fred Work, A. Auble and Ralph Owen made a trip from New York to Florida two years ago and in which Owen repeated the trip over another route last Winter, has been purchased by the Akron Automobile Garage Company, and will be located here permanently for advertising and demonstrating purposes.

**STODDARD-DAYTON PLANT AGAIN COMPLETE.**

DAYTON, O., April 27.—Before the smoke of the recent fire which visited the plant of the Dayton Motor Car Company, the work of rebuilding was begun, and the occasion of the completion of the large new concrete building was fittingly commemorated last week by the presentation of a handsome American flag and flag staff to the company by its employees, as a token of the confidence of the working staff in its employers. George Harrison, who acted as executive officer of the special flag committee, made the presentation speech, while J. W. Stoddard, president of the company, received the gift and made plain his great appreciation of the testimonial of the good wishes of his men. The new concrete building, six stories in height, is shown at the right of the photograph.



Flag Presentation at the New Stoddard-Dayton Building.



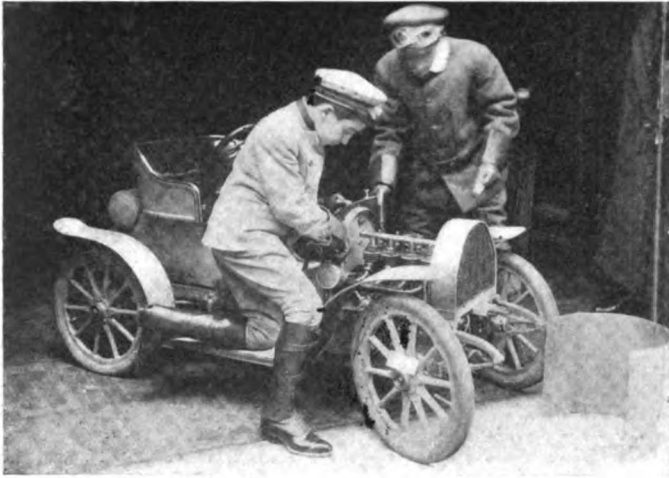

The Lurie Boys' Auto That Is Interesting New Yorkers.

### A LILLIPUTIAN AIR-COOLED AUTO.

What is probably the smallest gasoline-driven automobile ever built has just been delivered to George and Herbert Lurie, aged 13 and 11 years old respectively, and it is expected that it will soon be seen on New York City streets. It was specially built by A. Halverson to the order of John Lurie, the father of the boys, and when not in use will be exhibited at the salesrooms of the Auto Supply Company, 1733-1737 Broadway. Great pains have been taken to make it as exact a reproduction as possible of the large sized cars in everyday use, so that it is practically a reproduction on a small scale of a high-grade touring car.

Its power plant consists of a four-cylinder, air-cooled, F. N. motor, of which numbers are in use on motorcycles. Its dimensions are 2 inches bore by 2 1-4 inches stroke, and it is equipped with a Bosch high-tension magneto for ignition as well as an up-to-date system of lubrication. Its other specifications likewise conform to those of current practice, such as the pressed-steel frame, artillery wheels, sliding change speed gear, I-beam forward axle, semi-elliptic springs and the like. The tires are Hartfords on Midgley rims and measure 18 by 1 3-4 inches. The wheelbase is 46 inches and the tread 26 inches, while the gasoline tank has a capacity of two gallons of fuel. The car weighs 223 pounds all on, and is said to be capable of 40 miles an hour, though its wheelbase would make this a dangerous speed.

### FRANKLIN GREATLY ENLARGES TRUCK DEPT.

SYRACUSE, N. Y., April 27.—In a quiet way, the H. H. Franklin Manufacturing Company has been studying the commercial vehicle problem from a practical standpoint, and as the result of its experiments and inquiries has now undertaken the manufacture of commercial vehicles of the gasoline-driven type on a large scale. "The development of the motor truck and motor vehicle has been slow," said H. H. Franklin, in an interview. "The vehicles have lacked stability and have not been as economical as horses. From the start we have kept a careful record of all operating, repair and maintenance expenses, and now have commercial vehicles more economical than horses. We expect that our commercial car department will give employment to 1,500 additional men inside of three years."

The line of commercial cars that the Franklin company will place on the market for the season of 1909 will comprise a light delivery wagon of 1,000 pounds capacity, suitable for dry goods, grocery and other forms of light work, a 3,000-pound truck for ordinary usage, and a 4,000-pound truck for slightly heavier work. Various forms of bodies will be put on these chassis, so that the line will include hotel buses, ambulances, patrol wagons, and the like. Taxicabs will also be included and the company is now said to be working on an order for these cars for one of the leading New York companies.

### A. S. M. E. AND S. A. E. TO MEET AT DETROIT.

The third annual summer meeting of the Society of Automobile Engineers will be held in connection with the semi-annual meeting of the American Society of Mechanical Engineers at Detroit, Mich., June 25-27. The meeting of the latter will open June 23 and end June 26, the dates of the two gatherings overlapping in order that the members of both organizations may have the benefit of papers to be read at each.

The meeting of the automobile engineers will begin Thursday morning, June 25, by attendance at one of the morning sessions of the A. S. M. E., during which a paper on "Clutches, With Special Reference to Automobile Clutches," by Henry Souther, will be read, Mr. Souther being a member of both societies. Some of the other papers prepared by members of the American Society of Mechanical Engineers for reading at the meeting in question, are: "A Method of Checking Conical Pistons for Stress," by Prof. George H. Shepard; "Horsepower, Friction Losses, and Efficiencies of Gas and Oil Engines," by Prof. L. S. Marks; "Some Pitot Tube Studies," by Prof. W. D. Gregory, and "A Journal Friction Measuring Machine," by Henry Hess.

The papers to be read during the sessions of the Society of Automobile Engineers will include studies of oxy-acetylene welding processes, as used in automobile construction, which will be supplemented by an actual demonstration of some of the methods employed; efficiencies of different forms of gearing; storage battery practice; the single motor drive as applied to electric vehicles, and a number of other subjects, the complete program being made public later. Through the courtesy of the A. S. M. E., the members will obtain the benefits of reduced railway rates. The Detroit entertainment committee consists of H. E. Coffin, Henry Ford, Russell Huff, James Herron and Alonzo P. Brush.

### HOW AN AUTO REPLACED LOCO.

PECOS, TEX., April 22.—During the recent floods in Texas, the automobile played a prominent part. The Santa Fe railroad lost several bridges, and was left without an engine at Pecos, whereupon W. W. Pitts, of the Pecos Automobile Company, communicated with the general manager of the railroad and offered his aid. Mr. Pitts went to work on a four-cylinder double-chain drive Acme, and converted it into a railroad motor car. He secured push-car wheels and axles, and, by babbitting each end of a two-inch pipe and properly bolting it to the car in place of the regular axles, he turned the trick. He fitted 18-tooth sprockets, by using two pieces of well casing, 6 inches in diameter and 10 inches long. He bolted the sprockets to each rear wheel with six bolts through holes in the sprockets and holes drilled through the wheels. This made a rig that was a temporary railroad car carrying five and six passengers, while the Santa Fe was making temporary repairs. The Acme averaged 25 miles an hour, and at times reached 40. It was fitted with a Rushmore headlight, so it could run at night as well as day.



How an Acme Did Yeoman Railway Passenger Service.

### THE REEVES AIR-COOLED BUGGY CHASSIS.

To meet the widespread demand that has arisen on the part of carriage makers and others, for the purely mechanical parts of the popular buggy type of vehicle—that is, the engine, change-speed gear, and transmission—the Reeves Pulley Company, Columbus, Ind., has found it expedient to place on the market a complete chassis of this type, instead of confining its attention to the manufacture of the motors alone, as has hitherto been the case. The power plant consists of one of the Reeves, Model

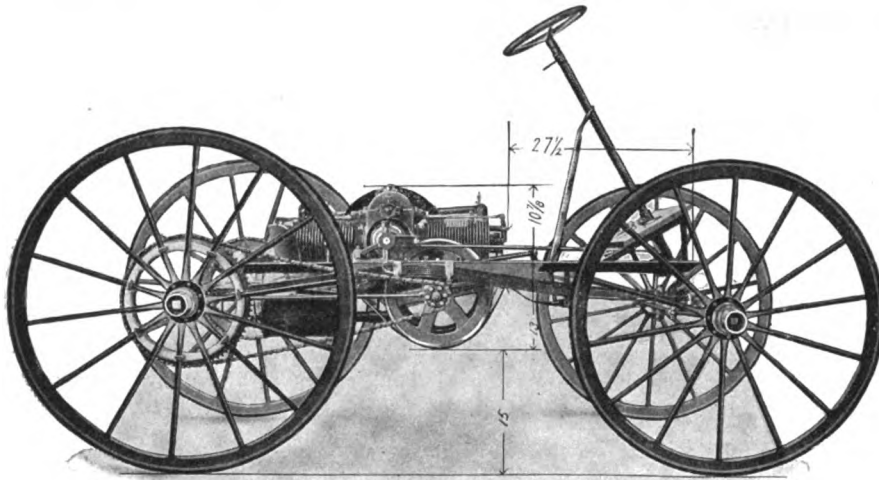

Side Elevation of the Reeves Complete Air-cooled Buggy Chassis.

N, 10-horsepower, two-cylinder, horizontal-opposed motors, which is used exclusively in this chassis. The cylinders measure 4 by 4 inches, the crankshaft being of hammered steel, turned and ground, and supported on long bearings. Gray iron is used for the crankcase, which has been so designed as to make all the parts of the motor accessible. Die-cast interchangeable bearings, hand-scraped to a true running surface, are employed, while the connecting-rods are of manganese bronze made adjustable on the connecting-rod end.

The distinctive feature of the Reeves chassis is its friction transmission, which is of an exclusive type, though the principle is an old one long utilized in the transmission of power in shops. A set of paper friction pulleys of different sizes is mounted on each end of the engine crankshaft, the smaller one of each set being mounted on a spline so that it may be telescoped into the larger by means of a pedal. Just forward of and below the engine is mounted a countershaft carrying two sets of aluminum friction pulleys. Each end carries a set and acts independently of the other. This countershaft, which is supported on roller bearings, carries the driving sprockets at its outer ends, and is hung in oscillating brackets, so that the aluminum pulleys may be rocked into contact with the engine friction pulleys by means of a hand lever. Two speeds forward are provided, the reverse being obtained by means of two idlers, adapted to be interposed between the pulleys on the engine shaft and the countershaft. From the sprockets carried on the ends of this countershaft, the final drive to the rear wheels is by means of double side chains, as shown. A wheel steer is employed, and the chassis, in other respects, approaches current engineering practice on larger and far more expensive cars.

### NEW FACTORY OF WARNER INSTRUMENT CO.

Some idea of the manner in which the demand for speed indicating instruments in general has increased during the past few years, and the Warner Auto-Meter in particular, may be gained from the following description of the new plant which the makers of these instruments—the Warner Instrument Company, Beloit, Wis.—have just completed and are now housed in. This company also makes other small indicating instruments of precision, such as anemometers, tachometers, railway autometers, and the like, and as the demand for these is said to have increased in the same proportion, it is probably not strange that no pains have been spared to make the home of the Warner products one of the most complete and thoroughly equipped industrial establishments west of Chicago.

The buildings were designed and erected by the Trussed Concrete Steel Company, of Detroit, Mich., and are constructed according to the Kahn system of reinforced concrete. The main shop measures 100 by 200 feet and has a saw-tooth roof with ten projections, the vertical sides of which are glazed with prism glass, thus leaving nothing to be desired in the way of lighting. Side windows have also been provided at the benches where the jewelers work, but they have been found unnecessary. The walls and ceiling—in fact, all parts of the interior—are finished in white, including the shafting and pulleys, in order to reflect every possible ray of light. This vast expanse of white wall will be maintained clean by making the factory dustless, as the windows will be kept closed and ventilation effected entirely by means of a blast system, in which every particle of air entering the building is "washed" by being passed through a fine spray of water, the air being warmed or cooled as necessary.

Not the least interesting part of the new plant is the system of shafting employed to drive the machinery. The supports are mounted on channel iron beams fastened to special cast-iron brackets, which were set in proper position in the concrete during the construction of the building. The point of greatest interest about this shafting is that it is all mounted on D. W. F. annular ball-bearings, the efficiency of which in this rôle may be imagined from the fact that one line of shafting 100 feet long and weighing 700 pounds may be turned easily with thumb and finger applied to shaft itself.

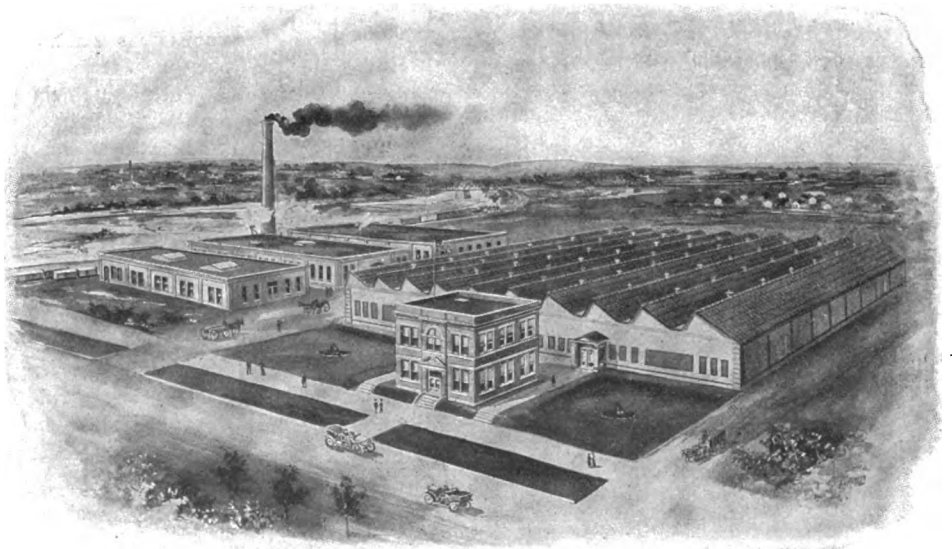

View of the New Plant of the Warner Instrument Company, Beloit, Wis.

### ENGLISH ROYAL PATENT FOR MICHELIN TIRES.

King Edward VII. of England has just granted the royal patent to the Michelin Tire Company, making that concern official purveyors of tires to the throne, and, incidentally, to the cars in the royal garage. This is a much coveted privilege, as it almost invariably results in the adoption of the article so favored by all the members of the court, the nobility, the near-nobility or aristocracy, and so percolates down the various social strata until its use has become universal among every class whose pocketbooks will stand the strain. In this instance, however, the King and his court have been using Michelin tires extensively for years, and the royal patent is of service merely as an added mark of distinction, and a recognition of services so well performed that the bestowal of the honor was a matter of course.



King Edward Entering His Car, Equipped with Michelins.

### WINTON DECLARES POLICY FOR NEXT YEAR.

CLEVELAND, April 27.—Alexander Winton, president of the Winton Motor Carriage Company, has just made public a statement to the effect that this company will continue to devote itself exclusively to the manufacture of six-cylinder cars during 1909. This is the first announcement regarding its future policy made by any company thus far, and is especially interesting, owing to the extended controversy that has been going on regarding the merits of the four- and six-cylinder types. "Our company, like other automobile companies, is in business to make what the public wants," said Mr. Winton, "and our experience in the manufacture and sale of the 'Six-Teen-Six' is convincing that every claim of advantage put forth can be demonstrated."

### A NEW TYPE OF PACKARD FIVE-SEATER.

A new type of Packard car that has made its appearance is fitted with a special body made of four individual seats and a tiger seat in the rear. It is in reality a combination touring car and runabout. The four passengers are seated in front of the rear axle, and, owing to this distribution of weight, easy riding qualities are claimed for it. It is somewhat lighter than the regular type of Packard touring car.

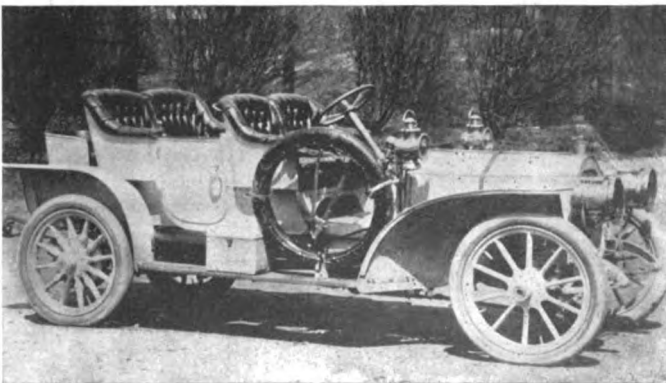

Latest Type of Packard Body That Will Seat Five.

### SPECIALTIES FOR POPULAR RUNABOUTS.

As a rule, the autoist has found that the manufacturer of accessories of various kinds—the many small things of more or less importance that are not a part of the car itself and that are not supplied by the builder, does not cater to the wants of the owner of the low-priced car to any great extent, and that as a rule many such articles are generally designed for high-priced cars. On this account, the Jenkins Specialty Manufacturing Company, Sumter, S. C., is placing on the market a line of specialties designed particularly for the five best selling makes of small cars, the Ford, Cadillac, Maxwell, Reo and Buick. It is a noticeable fact that the man who invests in a car of this kind generally does not make much attempt to keep it as clean and trim-looking as he would if it were a carriage, and it is a matter of common observation that the appearance of the average automobile and that of the horse-drawn vehicle for pleasure use are in strong contrast. To enable the owner of the small car to maintain it in better order in this respect, the makers in question make a specialty of a line of linen slip covers designed to fit the upholstery of any of the cars in question, also top hoods, running boards, inside mud splashers, under curtains, chain boots and the like, the accompanying photograph illustrating a Maxwell runabout fitted with their complete line.

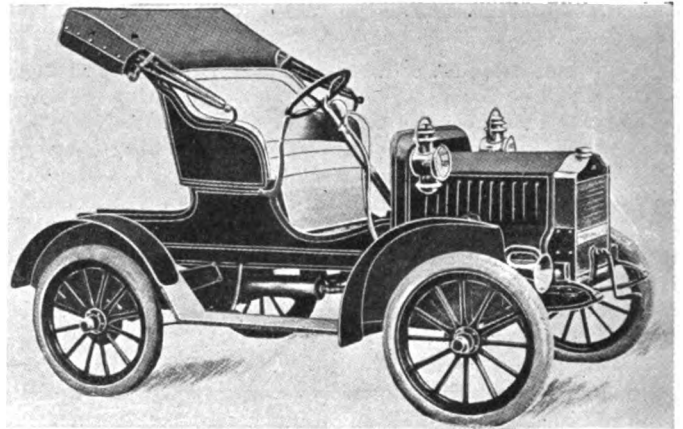

Maxwell Runabout Equipped with Jenkins Specialties.

### WESTERN GARAGES ARE FLOURISHING.

DES MOINES, IA., April 25.—Talk of hard times has apparently had little or no effect on the automobile business in this part of the country, for instead of plans of retrenchment for the coming season additional capital is being invested. Work has been completed on quite an ambitious addition to the garage of the Buck Automobile Company, under the supervision of its manager, W. E. Moyer. The new structure has taken the form of an L from the rear of the present building on Mulberry street, extending to Seventh street, which will give a second entrance to, and exit from, the establishment at that end. It measures 60 by 90 feet and is being constructed of brick and fireproof materials throughout, no effort being spared to make it a model of its kind. The present building already affords no less than 8,700 square feet of floor space, and with the addition in question this will be increased to 13,500 square feet. The Buck Auto Company has been handling the Pierce Arrow, Royal Tourist and Oldsmobile lines and recently added to these the Peerless and Cadillac.

Buffalo, N. Y.—A. C. Bidwell, jobber in automobile supplies, is building an absolutely fireproof garage at 72-74 Pine street, this city. The new building contains a number of special features in keeping with the progress and demand for high-class storage and attention to cars.

## SELDEN LICENSEES COMBINE TO HAVE ROYALTIES REDUCED

TRENTON, N. J., April 28.—In the action of the Hartford Rubber Works, of Hartford, Conn., against the defunct Electric Vehicle Company, which is pending in the United States Circuit Court for the District of New Jersey, a petition has just been filed by the receivers, Halsey M. Barrett and Henry W. Nichols, "praying its instruction and direction with regard to the making of a new agreement with the members of the Association of Licensed Automobile Manufacturers respecting the payment of royalties required to be made upon licenses granted to them under United States Letters Patent No. 549,160, commonly known as the 'Selden patent,' and the terms under which said payment shall be made."

This is the wording of the preamble of the notice issued by the receivers, but behind it there is an interesting bit of Selden history that has been in the making for some time past. A little less than half way down its second page it reads:

"Prior to the appointment of the receivers, the members of the association had insisted that a modification of the agreements should be made which would result in a substantial reduction of the royalties required to be paid thereunder, and since the appointment of the receivers a *large majority of them have refused to make payment* on any royalties, upon the ground that such royalties were excessive and oppressive."

The italics are ours, but they explain in a few words the cause of the present move. The Selden patent forms one of the chief assets of the Electric Vehicle Company, the affairs of which are now in process of liquidation, and the members of the Licensed association have placed themselves on record as being opposed to paying the debts of the bankrupt concern through the medium of royalties. The Hartford Rubber Works Company is suing the receivers of the concern as one of its chief creditors, and as the only source of income consists of the royalties paid by members of the Licensed association, the complainant's interest in the matter is plain. As a matter of fact, however, this refusal of the licensees to pay further royalties on the old basis is not merely the outgrowth of the failure of the Electric Vehicle Company, but is the culmination of a determined effort of a number of the members of the Licensed association, reports of whose activities in this direction have cropped out more or less frequently during the past year or so. The campaign has been carried on continuously, and the fact of the E. V. Company's insolvency was seized upon as an excellent opportunity to have the

matter settled without further delay. Hence the present petition of the receivers, who find themselves helpless in the premises.

The royalties payable under the Selden patent amount to 11-4 per cent. of the catalogue prices of the cars, except for export, in which case the royalty is one-quarter of one per cent. Of this amount three-fifths went into the treasury of the Electric Vehicle Company, from which Selden himself was reimbursed, the remaining two-fifths going to the Licensed association. To quote further from the petition, which asks a reduction of 20 per cent. in the present schedule: "This proposed agreement, if made, will reduce the royalties required to be paid by the members of the association by 20 per cent., with the further limitation that the royalties to be paid in any one year shall not exceed \$250,000."

But the matter of royalties is not the only thing for which the members of the Licensed association referred to have been working. A unanimous vote of the membership has been required to admit new members in the past, in addition to which the constitution of the association requires that all members admitted shall have been in the business of manufacturing automobiles, at, or prior to, the date of the formation of the association in 1902, thus effectively barring newcomers. It has been the aim of the members in question to have the bars let down, which explains the following excerpt from the petition, where it refers to the proposed new agreement, copies of which are on file at the court, as well as the receivers' offices in Newark, N. J., and Hartford, Conn. This part reads: "It also contains certain modifications of the terms upon which new members of the association may be admitted, and surrenders to the association control of litigation to compel payment of royalties in excess of the maximum annual amount of \$250,000, above referred to."

The contingency of a decision regarding the validity of the Selden patent being handed down in the interim is provided for by the following, referring to the new agreement in question:

"It also provides that should a decree be entered adjudging the Selden patent invalid, the royalty shall, pending an appeal from that decision, be paid to the trustee (the Morton Trust Company, trustee for the bondholders of the E. V. Company), to await the outcome of the appeal.

By an order of the court, granted April 25, a hearing on the petition is set for Monday, May 4, at which the creditors and stockholders of the Electric Vehicle Company may appear to argue for, or against, the granting of the petition.

## FOREIGNERS MUST AWAIT THOMAS CAR AT VLADIVOSTOK

BY a decision reached by the promoters of the New York-Paris race, the foreigners now *en route* to Japan and Vladivostok will be compelled to await the arrival of the Thomas car at the latter port, so that all the contestants will again start on an equal basis. Cables have been sent to the ports for which the contestants are bound, informing them of this change of plan, and the entrants have also been notified so that they may instruct their drivers to the same effect.

In the meantime, the E. R. Thomas Motor Company has made a formal demand for the cup. According to the preamble of the latter: "No withdrawal from the race will take place, but the

cup is claimed now on the rules laid down by *Le Matin* at the outset of the contest."

After relating in detail the course taken by the Thomas and the advantages gained, it continues: "The E. R. Thomas Company begs leave herewith to file an earnest protest against the action of these cars in not attempting to comply with the conditions of the race, and claims that, by failure of the others to go to Alaska, it has won the cup offered by *Le Matin*."

In stating that the car will continue, it is particularly specified that no rights to the cup are waived, and that a time allowance of at least 14 days be granted it.

## AMENDED NEW JERSEY LAW IS ALREADY IN FORCE

TRENTON, N. J., April 28.—Contrary to the generally prevailing impression that the amendment to the present New Jersey Motor Vehicle law is not to go into effect until June, it is now working as hard as temporary facilities, the lack of official stationery and the new number pads will permit. Receipts for license fees are temporarily acting as licenses, and the holders are at liberty to display the new numbers on any part

of the car they choose until the new pads are issued. A feature unduly oppressive is that requiring that all licenses expiring at any time before January 1, 1909, must be renewed, so that all expire December 31, 1908. More than that, no old law licenses will be transferable at a cost of one dollar, as has formerly been the case, the new owner being required to take out a license as if it were a new car.



## BRIEF ITEMS OF NEWS AND TRADE MISCELLANY

The Grout Automobile Company, Orange, Mass., is running its factory on full time, and, owing to increasing trade, has largely augmented its force of factory employees.

At the sale of the assets of Leon Rubay, at his former place of business on Broadway, between Fifty-third and Fifty-fourth streets, unusually high prices were obtained, the sale being attended almost exclusively by dealers.

High Point, North Carolina, now has an automobile line pending the construction of a street car line to Mechanicsville, a distance of two miles. W. C. York has purchased a twenty-passenger car for the service.

The Ford Motor Company is making music for the masses by arranging for free distribution of the "Ford March and Two-step," composed by Harry Zickel, a rag-time author of prominence. It is also planned to supply the lines to bands and orchestras and also in the form of records for automatic piano players.

Wyckoff, Church & Partridge, eastern agents for the Stearns, gave a dinner last Saturday night at Rector's, New York, in honor of the three Stearns pilots in the Briarcliff race—Frank Leland, Barney Oldfield and Guy Vaughan. All the local and several of the factory staff attended, including Treasurer Jacobs and Superintendent Patton.

In Denver, Col., fifteen real estate men use Franklin automobiles, and, with but two exceptions, they are Type G. One man writes the Franklin people that his car has paid for itself three times over in one year, and that the real estate business in Denver could not be conducted successfully under modern conditions without the use of autos.

An order for six seven-passenger Rambler cars has been placed with the Chicago branch of Thomas B. Jeffery & Company by the Big Horn Basin Development Company, for use at Cody, Wyo. The latter company is developing 245,000 acres of farm land in Wyoming by irrigation, and will use the cars to carry prospective purchasers to and from the railway station.

"Automobile progress in the West is rapidly gaining on the East," says E. H. Broadwell, of the Fisk Rubber Company. "The beginners there seem to know more about cars, their uses and limitations, than did the average Eastern man with his first car, and this same knowledge is particularly manifest where tires are concerned. Perhaps, in the West, they are profiting by Eastern experience, but whatever the reason, they are forging ahead."

Endeavors are being made to obtain a concession from the Mexican government for a stage line between San Diego, Cal., and Enseñada, Lower California. Byron Hall is backing the project, and if the concession is granted, will establish a line of passenger and freight auto busses, using 75-horsepower machines capable of making the round trip in less than a day. There is no railroad connection between the points in question, the only means of communication existing at present being by steamer, which is very slow, owing to the much greater distance that must necessarily be traveled in going around the coast line.

F. M. Hoblitt, known from coast to coast as a pioneer automobile salesman, and now traveling representative for the American Locomotive automobile, is father of the following expression that is causing considerable discussion. In speaking of the six-cylinder Locomotive car he says: "It possesses energetic mechanical instinct." The argument turns upon whether it is possible for a car to be so perfectly balanced as to warrant saying that it possesses instinct.

"There has never been such development in the same length of time in the product of any industry as has been shown in automobiles," said Hugh Chalmers, president of the E. R. Thomas Detroit Company, recently, in discussing the Thomas policy of entering race meets. "This is due largely to the races and endurance runs that have been conducted. These contests have shown the manufacturers the weak points of their machines, and have enabled them to strengthen their cars and make them more reliable."

Republic tires received a well-merited compliment in a story recently told by Edgar T. Dennis on himself at the automobile club. Before undertaking a 3,000-mile Winter tour through the Appalachian mountains, Mr. Dennis gave instructions to have the tires filled with a puncture-proof compound, and to have the two spares left at home. The driver misunderstood the order, except in so far as the spares were concerned, and Mr. Dennis was surprised on his return home to find that he had been many miles from help, or even a spare tube, for several weeks, and that his self-congratulations on the unexpected resiliency of the tires had been misplaced.

The Locomobile Company of America has just delivered one of its Tye E Locomobiles to Edward Mooney, chief of the Bridgeport (Conn.) fire department for use as a chief's car. A special chemical Locomobile has been in active service in Bridgeport since December last, and since that time has responded to over 100 alarms, and the steamer hose has only been on the hydrants five times in that period. Chief Mooney found that he was never getting to fires until some time after the chemical had extinguished them, and realized the need of superseding his horse conveyance with one more modern and speedier. The Locomobile people have sold a similar car to the South Park Commission of Chicago, for the use of Captain Richards. This car, however, is of the roadster type.

A side light on the expenses of a road like the Briarcliff and the immense amount of detail connected with the running of cars in these events was thrown out by a prominent oil man who visited the scene of the race yesterday. This was W. T. Kincaid, of the Harris Oil Company, of Providence, who went to New York in response to demands on the Isotta and other drivers, who asked that he personally see to the delivery of the oil which they were to use in the race. Mr. Kincaid said that after going the rounds of the training camps, he found that the cars in the race would use at least 500 gallons of oil of various kinds. When it is remembered that oil expense is one of the least of all the expenses of running a

car, some idea of what the race will cost the contestants can be formed. Mr. Kincaid said that much more than 500 gallons would be bought for the race, in order to have extra supplies at the various scattered stations around the course, but that some of this would not be used and a good deal of it would be held over for later use.

### NEWS ABOUT THE AGENCIES.

The Garfield Park Automobile Garage, Douglas boulevard and Harrison street, Chicago, has been appointed agent for the Grout car for that city.

The Pueblo Novelty Works has opened an up-to-date garage at 519-521 Court street, Pueblo, Col., and will handle the Rambler, Mitchell, Maxwell and Detroit electric. The new garage is to be run as a branch of the headquarters at 310 North Main street.

That Cleveland is very favorably regarded by the trade at large as a selling point is well illustrated by the way outside manufacturing concerns are opening up agencies there. Last week the Overland invaded the city, placing an agency, while the Knox, American and Overland are now figuring with the local dealers.

The National is now represented in Washington, D. C., by George Wells, who has opened a salesroom and garage at 1333 Fourteenth street, N. W. Lester D. Moore is the latest Washington dealer to locate on Fourteenth street, which is becoming known as the Capital City's automobile row. He will handle the Reo and Premier. Several dealers are bidding for the Oldsmobile agency, heretofore held by John Lutz, who has retired from the business because of ill health.

### RECENT TRADE CHANGES.

The Boston branch of Charles F. Kellogg & Company, of Philadelphia, makers of lubricating oils and greases, has moved from 91 Church street to larger quarters in the Motor Mart, at 87 Church street.

### PERSONAL TRADE MENTION.

Elmer Apperson announces that he has engaged Herbert Lytle to drive the company's Apperson cars in all races and other contests in which the factory may desire to participate.

Secretary Johnson, of the Automobile Club of St. Paul, was in New York this week looking over the ground as to the chances of securing entries for a big track meet during the Shriners' convention in that city. He enlisted the cooperation of Fred J. Wagner in the matter.

Marcus I. Brock, who was in charge of the sales department of the Autocar Company for three years prior to December, 1905, severing his connection with that concern to become assistant manager of the Association of Licensed Automobile Manufacturers, has just returned to Ardmore, Pa., to again take up his duties in the same position. He will have associated with him in the Autocar sales department H. M. Coale and F. G. Browning, and an active campaign will be immediately undertaken. As Mr. Brock is no stranger to the Autocar, he will have no difficulty in taking up the reins just where he let go.

**NEW TRADE PUBLICATIONS.**

**Bausch & Lomb Optical Company, Rochester, N. Y.**—Under the title of a "Triple Alliance in Optics," this firm is sending out an attractive booklet showing how the three foremost investigators in the world of optics—Carl Zeiss, Jena; George N. Saegemuller, and the Bausch & Lomb Optical Company, came to be associated. "The natural drift of scientific and economic tendencies has led to the fusion of the business interests of the Bausch & Lomb Optical Company, the Bausch, Lomb, Saegemuller Company, both of Rochester, and the Carl Zeiss Optical Works, Jena," reads the foreward. "This unification is the practical expression of a desire to concentrate the knowledge, skill, experience, and energy of the leading optical firms of two continents. Under the new régime the Bausch, Lomb, Saegemuller Company becomes an integral part of the Bausch & Lomb Optical Company, losing its identity as a separate corporation. The Zeiss works become members of the new corporate organization, and the intention is to manufacture certain products of the Jena works in the United States." The new concern will be known as the Bausch & Lomb Optical Company.

**Pope Manufacturing Company, Hartford, Conn.**—One of the most attractive car catalogues of the season is that of the Pope-Hartford cars. It is not only an excellently executed piece of work from a typographical point of view, but it reflects the long experience that the Pope publicity forces have had in catalogue making. It is a 30-page, flexibly bound pamphlet, printed on heavy surfaced paper and strikingly illustrated in colors. This refers more particularly to the different models of the cars themselves, there being numerous other illustrations of parts and departments of the works in half-tone on tinted backgrounds. The motor as well as the other essential parts of the car are illustrated in detail, while their manufacture is described at length. The cover is attractively illustrated by two panels, one showing a party starting out in the morning, and the other, returning at night.

**Halsey Auto Company, St. Louis.**—What is probably the most effective way of showing second-hand automobiles to prospective purchasers at a distance, takes the form of a catalogue of used automobiles sent out by this firm. It is a work in which the photographer has played a more important part than the printer, as apart from a three-line notice over the signature of O. L. Halsey, president of the company, guaranteeing all cars offered to be exactly as represented, and the briefest possible description of the cars themselves, the photographs are allowed to do their own talking. The cars have been pictured exactly as they stand, without any attempt at making them more attractive than they are by retouching or providing an artistic background. The date of original delivery, make, model, mileage covered and the selling price, as well as the maker's price, comprise the data given below each picture.

**Spittdorf Laboratory, 261-265 Walton avenue, New York.**—"Automobile and Gas Engine Ignition Apparatus" is the title of a booklet now being sent out by this pioneer house in the manufacture of electrical specialties for the automobile. As Spittdorf has been a name associated with the making of electrical apparatus for half a century past, no superfluous words are wasted in introducing the reader to the subject, so that the entire Spittdorf line, including high and low-tension magnetos, dash coils, the Spittdorf synchronized multi-cylinder coil, motorcycle coils, motorcycle magnetos, Spittdorf timers and spark plugs, switches and the like, as well as illustrations and descriptions of replacement parts for everything listed, is fully covered in a 34-page pamphlet.

**Thomas B. Jeffery & Company, Kenosha, Wis.**—Rambler automobiles form the subject of catalogue, number 15, just issued by this old and well-known house, and it is certainly a fitting vehicle to carry the Rambler message to thousands of prospective buyers, who are looking for "the car of steady service." Just why the Rambler cars have achieved this title, is fully explained in the greatest detail in connection with the description and illustration of every essential of the car. The story is interestingly told and is enlivened by numerous illustrations of Rambler cars amid many different scenes. The cover bears the name Rambler heavily embossed in red and in the style that has long been a distinguishing feature with this house, while the frontispiece is a Rambler touring car in several colors.

**Renault Freres, 1776 Broadway, New York.**—Paul Lacroix, general sales manager for the Renault Freres Selling Branch for the United States and Cuba, is now distributing a facsimile of the large catalogue sent out by the home firm, translated into English.

It tells of the numerous achievements that the builders of these cars have to their credit ever since 1899, besides describing in detail the numerous models that they list, ranging from a 9-horsepower, two-cylinder chassis, up to a 50-60-horsepower, six-cylinder machine. The catalogue is attractively printed on good paper and is interestingly illustrated by halftones of numerous scenes on foreign racing courses in which Renault cars figure prominently, beside which there is a number of views of the extensive works at Billancourt, France.

**E. R. Thomas Detroit Company, Detroit.**—"Thomas-Detroit Doings" is the title of a new periodical which will be issued by this concern henceforth, as a means of extending a helping hand to the hundreds of Thomas agents all over the country. It is a four-page sheet, measuring 9 by 12 inches, and is attractively printed in colors. The doings of the Thomas and the plans of its makers will be chronicled therein weekly, the first two issues being dated April 10 and 17. "Published by the E. R. Thomas Detroit Company to help our agents sell Thomas-Detroit Forty cars" briefly explains its mission.

**Motor Car Equipment Company, 55 Warren street, New York.**—The 1908 catalogue of this concern, which is the most attractive piece of trade literature of its kind that has been received in some time, is said to contain the most complete variety of automobile supplies listed. It is not the largest book of its kind by any means, but an example of its compactness is to be found in the fact that no less than eighteen different varieties of spark plugs are illustrated and described in two of its 8 by 10-inch pages. As there are 90 pages, equally condensed, the amount of matter contained will be apparent. The index is particularly complete, each article being listed by its accepted trade name, as well as the maker's name and the popularly used term.

**Warner Instrument Company, Beloit, Wis.**—"The Warner Autometer," surmounting an embossed illustration of the Autometer itself in gilt, which in turn is followed by the legend "Tells how fast and far," forms a catalogue cover that has become familiar. A speedometer is an instrument that comes within the category of "apparatus of precision," and as such requires extremely accurate machinery and painstaking care to manufacture, in addition to which it must be made strong enough to withstand the jars and jolts it receives on an automobile. Just how this is done is told in detail in the Warner Instrument Company's catalogue, the story being interspersed with numerous half-tone illustrations.

**Rainier Motor Car Company, New York City.**—As the completion of the new Rainier plant at Saginaw, Mich., was effected not long before the issue of the Rainier catalogue for the present season, a description of this latest addition to the country's growing list of modern automobile factories has been appropriately employed in the shape of an introductory to the description of the Rainier models, which follows. Each page carries an illustration of a car, or some part, and is printed on white surrounded by a tint border, while across the top of each page, there is a panel carrying a line sketch showing Rainier cars in familiar settings, the world over.

**Barrett Manufacturing Company, New York City.**—Another pamphlet from this firm enclosed in a cover adorned by a most attractive view of park roadway, and emblazoned in one corner by the announcement "Tarvia, the dust layer," constitutes the latest addition to the literature of the subject which has recently made its appearance. Its purpose is to describe a new Tarvia treatment, and in doing so, excellent use is made of half-tone illustrations to show a number of specimen stretches of road that have been perfected with Tarvia.

**General Automobile Supply Company, New York City.**—Automobile accessories and tools of every imaginable nature and at net prices, form the contents of a new catalogue just issued by this firm. Complete lines are handled both at the down-town headquarters at the above address, as well as at the up-town store located at Broadway and Fifty-second street. Every article is illustrated and described in detail, the firm doing a large mail order business. The 1908 catalogue is a 74-page booklet, attractively printed.

**Lovell, McConnell Manufacturing Company, Newark, N. J.**—This concern is now sending out a booklet describing and illustrating the new "Klaxon" warning signal, of which Miller R. Hutchinson, 1 Madison Square, New York, is the patentee and inventor. The booklet describes the numerous uses to which the "Klaxon" is applicable and makes interesting reading of the process. The "Klaxon" is made in two types, one

mechanical, and the other electrical, and the manner of their application is described in detail.

**Mathew Strauss, 707 Main Street, Buffalo, N. Y.**—A general line of automobile and gas-lighting supplies and accessories is listed in the 1908 catalogue just being sent out by this house. It is a book of 90 pages, measuring 7 by 10 inches, and contains a showing of all the standard supplies, such as lamps, horns, gas tanks, clocks, tire and robe holders, carbureters, mufflers, force-feed oilers, speedometers, shock absorbers, pumps, windshields, clothing, goggles and the like, in addition to a full line of tools.

**Monarch Motor Car Company, Chicago Heights, Ill.**—"Monarch 1908" is the cover caption of an attractively written booklet descriptive of the design and construction of the New Monarch car, which is being built by this firm. The entire 28 pages are given over to a detailed showing of every essential of the car, most of them being illustrated by half-tones, in addition to which there are a number of line sketches, showing the motor and change-speed gear in section, and the forward half of the chassis in plan.

**Joseph Dixon Crucible Company, Jersey City, N. J.**—Autoists are never permitted to forget the fact that Dixon's graphite lubricants are on deck. Their latest arguments in favor of this method of lubrication are contained in two booklets, one of which is devoted to graphite lubrication of automobile gear boxes and transmissions and the other a compilation of "Questions and Answers on Automobile Lubrication," the cover bearing a sketch of the Sphinx with an auto in the foreground.

**Canada Cycle & Motor Company, Toronto Junction, Ont.**—This concern builds the Russell car and is now sending out an attractive catalogue describing the models being turned out for 1908. It is an 8 by 10, 28-page pamphlet, which is very attractively gotten up from a typographical point of view, and is devoted entirely to the business of showing how the Russell cars are made and what is used in their construction.

**Detroit Lamp Company, Detroit, Mich.**—Fourteen different lines in automobile search-lights, side lights and tail lamps are comprised in the Detroit company's catalogue for 1908. Each type of lamp is illustrated by half-tone engravings.

**A LIVE MOTORCYCLE AGENT.**

John T. Fisher, the veteran cyclist, who is now manager of the Chicago branch of the Hendee Manufacturing Company, of Springfield, Mass., makers of the Indian motorcycles, is a firm believer in the future of the power-driven two-wheeler. During the recent carnival in Chicago, the Indian headquarters, at 1251 Michigan avenue, were decorated, and Mr. Fisher was a prominent figure in the parade. A largely increased demand for motorcycles is a feature of this season's trade.



John T. Fisher.

INFORMATION FOR AUTO USERS

**L. & M. Specialties.**—Among the accessory specialties manufactured by the Long & Mann Company, Rochester, N. Y., for the automobile trade are the "Minute" adjuster to facilitate the removal and replacement of clincher tires, and which has

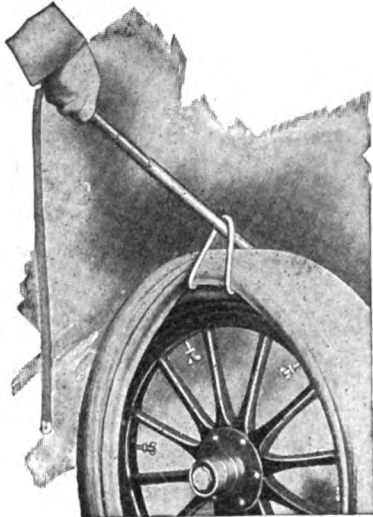

L. & M. TIRE SHOE LIFTER.

now been made so as to fit in any tool box; the "L. & M." Adjusters, designed to be used in connection with quick detachable tires and removable rims, and which are said to be the only tools made for use in connection with these tires. The

sponge washer in that the sponge used is made of cotton mop yarn, and is in fact, a mechanical sponge. It is so constructed that the water cannot escape in the form of a stream at any point, but is very evenly distributed, while it also checks any excess pressure of the water supply and is thus economical with water, as well as in first cost.

**Mather Dismountable Rim.**—This is a new type of demountable rim that is the invention of Frederick R. Mather, of Wellsville, N. Y. The wheel shown in the accompanying illustration has been run several hundred miles and has stood every test most successfully. It is merely an old wood wheel cut down and fitted with the inventor's attachments, the latter's design calling for a tubular steel spoked wheel of neat design and appearance, and which

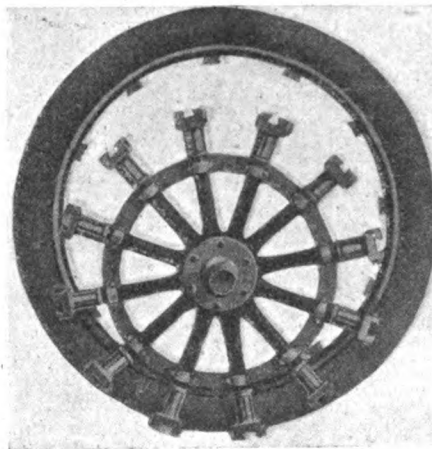

MATHER RIM AND GENERAL DETAILS.

will embody several improvements not shown on the model. As will be evident from the cut, this new type of demountable rim is simple and strong in construction, making it very durable, while it is also easy to operate. In fact, it represents one of the quickest methods of changing tires on the road. The Mather rim and wheel were shown for the first time at the recent Buffalo automobile show, where they attracted considerable favorable attention. It is expected to place them on the market during the present season.

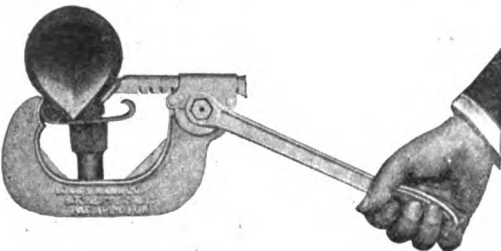

L. & M. TIRE SHOE LOOSENER.

"L. & M." Tire Shoe lifter is a new and simple tool and is designed as an adjunct to the "Minute" outfit, while the Tire Shoe loosener recently brought out is distinctly new and different from any other tool on the market, both in action and efficiency,

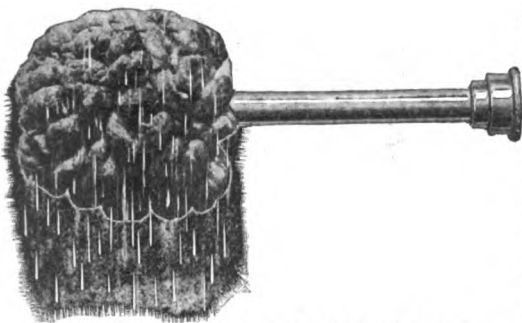

"PERFECT" AUTO AND CARRIAGE WASHER.

and is not only a necessity to every autoist, but to every garage and repair shop as well. The "Perfect" auto and carriage washer is also new, and represents an improvement over the ordinary type of

**Cleveland-Canton Auto Springs.**—The manufacture of springs for automobile suspension is a branch of the industry that has been developed along specialized lines, probably more than any other that has to do with the making of parts of the car. In fact, it has been brought to a point where it may well be compared to the making of watch-springs. One of the firms that has been responsible in large measure for this trend of development is the Cleveland-Canton Spring Company, Canton, O. Every possible combination of steels and alloys has been tried out to get just the right materials for successfully meeting the unusual requirements of automobile work, and this company has demonstrated the fact that while there are thousands of possible combinations of steels, that only a few can be successfully used in the manufacture of automobile springs, and an attractive booklet they have just issued, explains in simple language just why this is so, thus making it a piece of advertising literature

that will be of equal interest to owner and manufacturer alike. They also illustrate a number of the various types of springs commonly used on automobiles, such as the full-elliptic, button head; semi-elliptic, scroll-end elliptic, double-scroll, three-point suspensions, commercial vehicle suspensions and the like.

**"Three Ball" Gasoline Tester.**—One of the greatest disadvantages of the usual type of gasoline tester or hydrometer has been that a special containing vessel was necessary to hold the latter. To overcome this, the Storage Battery Supply Company, 239 East Twenty-seventh street, New York City, have brought out an ingenious instrument, termed the "Three Ball" gasoline tester, which is shown in the accompanying illustration. By dropping this device into the tank, barrel or can of fuel to be tested and withdrawing it, the specific gravity of the gasoline may be seen at a glance. The balls are red, white and blue, and each one sinks or floats according to the character of the liquid. The instrument will pass through a 3-4-inch hole, and requires only 1-4 ounce of gasoline to fill it, while the whole instrument is so small that it can readily be carried in the waistcoat pocket.



PATENTED 1904.  
THREE BALL TESTER.

**Torbensen Motors.**—With a view to producing a motor that would work all day and every day, with a minimum of trouble, the Torbensen Motor Car Company, Bloomfield, N. J., has brought out a line of air-cooled, double opposed, horizontal, four-cycle motors. They are made in two sizes, 4 3-8-inch bore by 4-inch stroke, rated at 12-horsepower, and 5 1-8-inch bore by 4 1-2-inch stroke, rated at 18-horsepower. Both are given a perfect running balance, while all bearings are of large size, the crankshafts being one-piece drop-forgings, ground on the journals, while the connecting rods are also drop-forgings of the same material. The cams and rollers are of tool-steel, hardened, while the bearings are of white brass, the main journals of the 18-horsepower motor measuring 1 3-4 inches diameter by 3 1-4 inches long, while the smaller motor has 1 5-8 by 3-inch journals. The cylinders

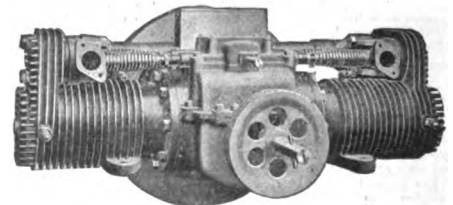

TORBENSEN AIR-COOLED HORIZONTAL MOTOR.

are offset so that they are directly in line with the cranks. The lubrication of all wearing parts has been worked out in the most efficient manner, while every part of the motors is made to standard gage and is interchangeable to facilitate replacements. The 12-horsepower motor is suitable for high-wheelers and light runabouts, while the larger motor is adapted for higher-powered runabouts, light touring cars and delivery wagons up to 1,500

pounds capacity. They can be made to run in either direction and their normal speed is 1,200 r.p.m. They are listed complete with carbureters, intake manifolds, spark timers, plugs, fan, oil connections and the like.

**Borbein Special Bodies.**—The Borbein Auto Company, 2109-2111 North Ninth street, St. Louis, have added two specialties in the shape of a complete automobile

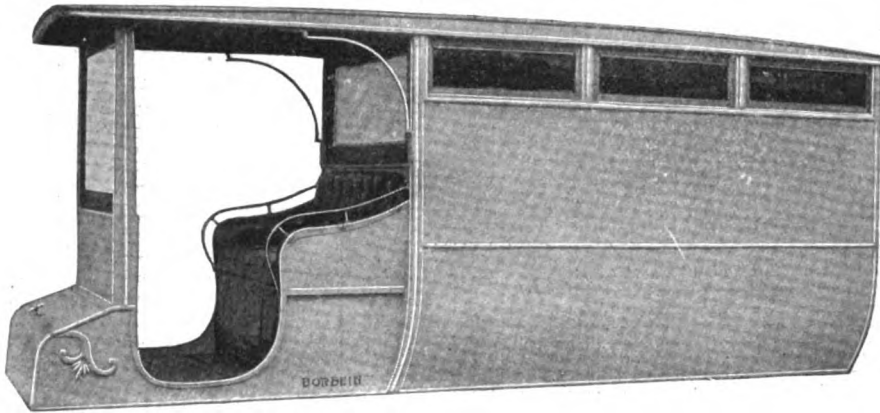

BORBEIN NO. 25 AMBULANCE BODY, WITH SPECIAL VENTILATION.

ambulance body and a roadster type to their already extensive line of running gears and bodies for the season of 1908. The ambulance is a special design and represents rather a radical departure from

speed-gear, final drive being by propeller shaft, while all essentials of the entire transmission are exactly in line. The front axle is of the tubular type, with Timken roller-bearings, while a live rear-axle of the floating type is employed. Suspension is by means of full elliptic springs in the rear and semi-elliptics front. The wheelbase is 106 inches and the tread standard, while the complete car tips the scales at 1,900 pounds. One of the features of the car that the

makers call particular attention to, is the ability to start on the high speed without any difficulty, owing to the use of a multiple disc transmission. Several types are made, including the Model A touring car, gentle-

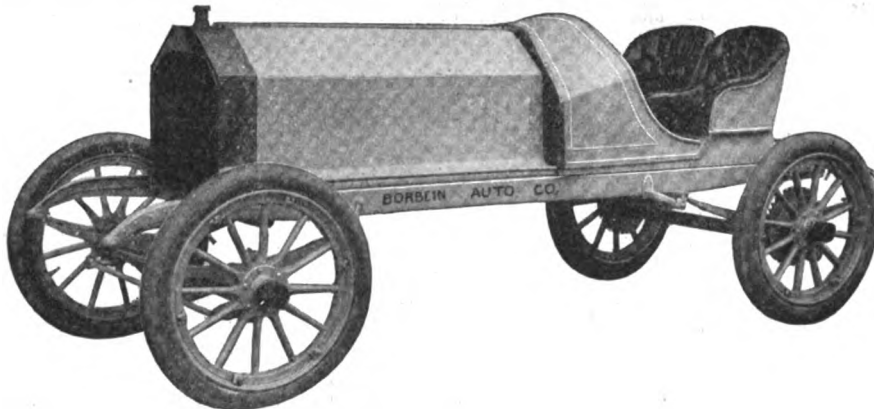

BORBEIN NO. 35 SEMI-RACING TYPE CAR READY FOR POWER.

hitherto accepted standards in this respect, over which it is quite an improvement. For instance, ventilation is specially provided for by a row of three narrow panel openings on each side along the upper edge of the sides of the body, while the driver is protected by a glass windshield and light is admitted to the interior of the body by means of a large pane occupying the entire space above the upholstery of the driver's seat. The special 1908 roadster is of the semi-racing type, in which seats are placed at the extreme rear of the chassis, the seating capacity being limited to two. It is known as Borbein car No. 35, and consists of a running gear and body complete and ready for the power.

**The Fuller Car.**—This is a brand new comer in the field, that hails from Angus, Neb., a place close to the geographical center of the United States. It is being made by the Angus Automobile Company, and while an assembled car, in large measure, incorporates a number of exclusive features. Its power plant consists of a four-cylinder Rutenber motor rated at 35-40 horsepower, and coupled by means of a three-jaw clutch to a special type of change

men's roadster, Model C runabout, Medium touring car, and a six-cylinder, 60-horsepower touring car.

**Continental Self-Oiling Motor.**—Under the title of Model K, the Continental Motor Manufacturing Company, Muskegon, Mich., is just placing on the market a simplified type of four-cylinder vertical motor. It embodies all the excellent features of design of previous models of the Continental motors, but has been designed particularly with a view to producing a motor having the least number of parts and which shall be as durable, efficient and economical as possible. The cylinders are offset, the valves all being placed on the right side, where the carbureter, timer and magneto are also located, the magneto be-

ing driven from an extension of the pump shaft. This arrangement requires the use of but three gears, thus reducing noise from that cause to a minimum. The magneto may be taken off simply by removing a single set screw and the pump is also easily removable for inspection and repair. The valve-operating mechanism is extremely simple, the plungers being of the mushroom type, and these, as well as the cams, which are integral with their shaft, being hardened and carefully ground to size. The valve timing is accurately inscribed on the flywheel periphery as a guide for retiming. Both the connecting rods and crankshaft are drop forgings of high-grade steel, the bearings and bushings being of the best white bronze. A special feature of the new motor is its automatic lubricating system, consisting of a constant oil level in the crankcase for splash oiling with an overflow to a well, from which a small gear pump driven from the timer shaft lifts the oil and forces it into the crankcase proper, thus making a constant circulation. The cylinder dimensions are 4 1-4 by 4 1-2 inches and the rating is 24-28 horsepower. The weight complete is 300 pounds.

**Fisher Storage Battery Charger.**—It is a well-established fact that the storage battery furnishes the best possible source of ignition current, and if it were not for the constant necessity of removing the battery to recharge it, this would form the ideal type of high tension ignition. To overcome this inconvenience, the A. W. Fisher Company, South Bend, Ind., have brought out their Fisher automatic storage battery charger, designed to automatically maintain the batteries of a car fully charged at all times. It is the invention of a gas engine expert who has had 20 years' experience in this field, and it is fully covered by patents. The generator may be either friction or belt driven and may be readily installed anywhere near the engine. The amount of current drawn from the batteries for ignition service is automatically replenished by the generator which supplies current to the batteries as long as the engine is running. In order to prevent the battery discharging through the generator when the engine is stopped, an automatic circuit breaker, or cut-out, is provided. This opens the circuit, the moment the engine speed drops to a point where the generator ceases to supply current to the battery, and immediately closes the circuit again on the resumption of normal speed, or the restarting of the engine after it has been idle. The device is entirely mechanical and thus positive in action. It provides a means of enjoying the reliability and plentiful supply of current given by the storage battery without the disadvantage of frequently having to recharge the latter.

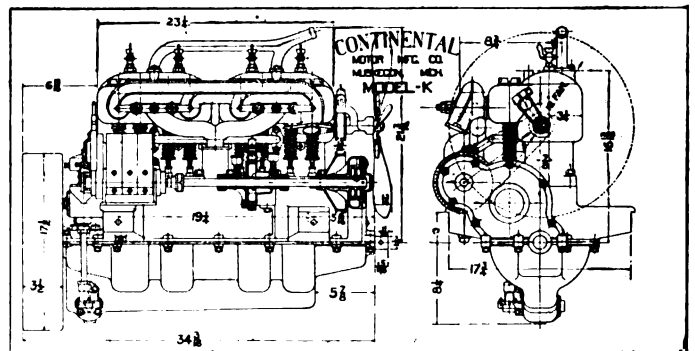

OUTLINE SIDE AND END VIEW OF CONTINENTAL MODEL K.



**INDEX  
TO ADVERTISERS**

Abrams-Mason Co. .... 87	Cowles & Co., C. .... 51	Jeffery & Co., Thos. B. .... 111	Post & Lester Co. .... 93
Acetylene Gas Illuminating Co. .... 54	Crane Puller ..... 54	Jeffery-DeWitt Co. .... 51	Precision Appliance Co. .... 66
Acme Motor Car Co. .... 56	Crown Soap Co. .... 72	Jenckel Motor Mfg. Co. .... 72	Premier Motor Mfg. Co. .... 102
Adams Co. .... 56	Cullman Wheel Co. .... 51	Johnson Sporting Goods Co., I. .... 57	Prest-O-Lite Co. .... 71
Aerocar Motor Co. .... 56	Davies Co., J. P. .... 76	Jones Speedometer ..... 89	Progressive Mfg. Co. .... 73
Ajax-Grieb Rubber Co. .... 57	De Luxe Motor Car Co. .... 56	K. W. Ignition Co. .... 90	Quinby Co., J. M. .... 54
Almy Water Tube Boiler Co. .... 51	Detroit Steering Wheel Co. .... 92	Keystone Lubricating Co. Cover	Raimles & Co. .... 51
Am. Brass & Alum. Works. .... 52	Diamond Chain & Mfg. Co. .... 52	Kimball Tire Case Co. .... 66	Rainier Co. .... 57
Amer. Motor Car Sales Co. .... 102	Diamond Rubber Co. .... 101	Kinsler-Bennett Co. .... 80	Randall-Falchney Co. .... Cover
American Locomotive Motor Car Co. .... Cover	Dien, Ch. .... 88	Kissell Motor Car Co. .... 96	Rauch & Lang Carriage Co. .... 90
Anderson Forge & Machine Co. .... 52	Dietz Co., R. E. .... 70	Knox Automobile Co. .... 94	Reeves Pulley Co. .... 56
Angier Co. .... 76	Dixon Crucible Co., Joseph. .... 68	Kokomo Electric Co. .... 89	Remington Tool & Machine Co. .... 66
Apperson Bros. Automobile Co. .... 103	Dorris Motor Car Co. .... 84	Konigsloew, Otto ..... 52	Remy Electric Co. .... 54
Appliance Mfg. Co. .... 66	Dover Stamping & Mfg. Co. .... 80	Lavalette & Co. .... 98	Republic Rubber Co. .... 92
Ashabula Bow Socket Co. .... 54	Duplex Coll Co. .... 54	Lear Automobile Co., Oscar. .... 56	Rex Wrench Co. .... 73
Atlas Motor Car Co. .... 56	Duplex Co. .... 68	Leather Tire Goods Co. .... 57	Richardson Engineering Co. .... 67
Auburn Automobile Co. .... 56	Earl Motor Car Co. .... 56	Limousine Carriage Mfg. Co. .... 54	Robert Instrument Co. .... 51
Audel & Co. .... 69	Echo Horn Co. .... 75	Lipman Mfg. Co. .... 51	Robinson & Sons Co., Wm. C. .... 82
Aurora Motor Works. .... 56	Eclipse Machine Co. .... 52	Lobe Pump Co. .... 68	Rock Island Tool Co. .... 77
Austin Automobile Co. .... 56	Edmunds & Jones Mfg. Co. .... 51	Locke & Co. .... 79	Royal Equipment Co. .... 58-68
Auto Car Equipment Co. .... 82	Eldredge Electric Mfg. Co. .... 51	Lockwood Bros. .... 86	Rushmore Dynamo Works. .... 100
Auto Pump Co. .... 65	Elite Mfg. Co. .... 77	Locomobile Co. .... 56	Sager Co., J. H. .... 65
Auto & Supply Co. .... 65	Ellsworth, J. M. .... 106	Logan Construction Co. .... 56	Sailsbury Wheel Mfg. Co. .... 52
Auto-Bi Co. .... 91	Elmore Mfg. Co. .... 97	Long Arm System Co. .... 75	Samson Leather Tire Co. .... 94
Autocar Co. .... 91	Empire Automobile Tire Co. .... 83	Long Mfg. Co. .... 73	Selden Motor Vehicle Co. .... 69
Auto-Shine Co. .... 51	Empire State Tire Co. .... 51	McCord & Co. .... 68	Shawver Co. .... 51
Automobile Blue Book. .... 55	Empire Wheel Works. .... 52	Maple City Mfg. Co. .... 72	Smith Mfg. Co., R. H. .... 57
Automobile Supply Co. .... 66	Excelsior Supply Co. .... 71	Manhattan Storage Co. .... 51	Smith & Sons, S. .... 87
Automobile Utilities Co. .... 57	Fairmount Engineering Wks. .... 56	Martini Import Co. .... 79	Southwick, T. T. .... 65
Avery Portable Lighting Co. .... 72	Firestone Tire & Rubber Co. .... 57	Marvel Mfg. Co. .... 89	Spacke Machine Co., F. W. .... 79
Baldwin Chain & Mfg. Co. .... 52	Fisk Rubber Co. .... 84	Mason, John A. .... 54	Spare Motor Wheel of Am. .... 78
Banker Bros. Co. .... 78	Flandrau & Co. .... Cover	Masury & Son, John W. .... 85	Speed Changing Pulley Co. .... 78
Barndt-Johnson Auto Sup. Co. .... 54	Flentje, Ernst ..... 76	Matheson Motor Car Co. .... 96	Spicer Universal Joint Mfg. Co. .... 52
Barnett Drop Forging Co. .... 50	Forest City Motor Car Co. .... 91	Mayo Radiator Co. .... 54	Spittdorf, C. F. .... 77
Beaver Mfg. Co. .... 85	Franklin Mfg. Co., H. H. .... 109	Mechanical & Electrical Mfg. Co. .... 58	Sprague Umbrella Co. .... 80
Behen-Faught Motor Car Equip. Co. .... 66	French Mfg. Co. .... 68	Merchant & Evans Co. .... 70	Springfield Metal Body Co. .... 54
Beloit Supply Co. .... 65	Fry, T. C. & W. L. .... 66	Merritt & Co. .... 66	Standard Automatic Lub. Co. .... 65
Black Mfg. Co. .... 74	G & J Tire Co. .... 58	Meyers & Sons, C. G. .... 54	Standard Co. .... 86
Blasier Mfg. Co., M. E. .... 54	Gabriel Horn Mfg. Co. .... 86	Mezger, C. A. .... 83	Standard Welding Co. .... 79
Bliss-Chester Co. .... 51	Garford Motor Car Co. .... 86	Michellin Tire Co. .... 104	Star Speedometer Co. .... 86
Borbein Auto Co. .... 71	Gearless Transmission Co. .... 53	Midland Motor Car Co. .... 66	Steam Carriage Boiler Co. .... 51
Bosch Magneto Co. .... 90	Geisler Bros. .... 51	Miller Bros. .... 70	Stearns Co., F. B. .... 61
Boston Auto Gage Co. .... 51	Gemmer Mfg. Co. .... 76	Miller, Chas. E. .... 82	Stevens-Duryea Co. .... 99
Bowers Co., F. E. .... 72	General Accumulator and Bat- tery Co. .... 57	Miller & Starr. .... 66	Studebaker Automobile Co. .... 89
Bowser & Co., S. F. .... 57	Gibney & Bros., Jas. L. .... 58	Mitchell Motor Car Co. .... 56	Stitch-in-Time Vulcanizer Co. .... 70
Boyle & Co., John. .... 78	Gilbert Mfg. Co. .... 72	Model Automobile Co. .... 56	Streator Motor Car Co. .... 77
Brownell Motor Co., F. A. .... 51	Goldberg Motor Car Devices Mfg. Co. .... 60	Moline Automobile Co. .... 96	Success Auto Buggy Co. .... 57
Brush Runabout Co. .... 84	Groat Bros. Auto Co. .... 100	Monarch Motor Car Co. .... 57	Supplementary Spiral Spring. .... 92
Buckeye Jack Mfg. Co. .... 67	Gray & Davis. .... Cover	Moon Motor Car Co. .... 82	Swinehart Clincher Tire Co. .... 76
Buckeye Mfg. Co. .... 56	Gray-Hawley Mfg. Co. .... 76	Morgan & Wright. .... 60	Syracuse Aluminum & Bronze Co. .... 85
Buffalo Carbueter Co. .... 98	Ham Mfg. Co., C. T. .... 75	Mosler & Co., A. R. .... 73-70	Thomas Motor Co., E. R. .... 78
Bullard Specialty Co. .... 54	Hardy Co., The R. E. .... 66	Moss Photo Engraving Co. .... 88	Thompson Sons Co., J. P. .... 65
Buob & Scheu. .... 54	Harris Oil Co., A. W. .... 53	Motor Car Equipment Co. .... 69	Timken Roller Bearing Axle Co. .... 95
Burlington Basket Co. .... 66	Hartford Suspension Co. .... 64	Motz Clincher Tire & Rub. Co. .... 57	Tray Plate Battery Co. .... 77
Burrowes & Co., E. T. .... 85	Hatcher Auto Parts Co. .... 73	Muller, Albert ..... 54	Triebert Gas Engine Co. .... 57
Cadillac Motor Car Co. .... 56	Haynes Automobile Co. .... 83	Mutty Co., L. J. .... 54	Trojan-Hydro Pneumatic Wheel Co. .... 79
Cameron Car Co. .... 57	Healy Leather Tire Co. .... 57	Myers Auto Top Co. .... 54	Tucker, C. F. .... 51
Canton Drop Forge & Mfg. Co. .... 52	Heinze Electric Co. .... 70	National Auto Accessories Co. .... 51	Turner Brass Works. .... 52
Capitol Auto Co. .... 54	Hercules Auto Specialty Co. .... 69	National Motor Vehicle Co. .... 99	Two-Spot Mfg. Co. .... 79
Champion Co., A. .... 79	Hercules Electric Co. .... 67	Neustadt Auto & Supply Co. .... 88	Uncas Specialty Co. .... 68
Chase-Shawmut Co. .... 50	Herz & Co. .... 65	Never-Miss Spark Plug Co. .... 54	Utility Co. .... 77
Chelsea Clock Co. .... Cover	Hess-Bright Co. .... 52	New Process Rawhide Co. .... 76	Vacuum Oil Co. .... 87
Clark, E. S. .... 51	Hicks Speed Indicator Co. .... 78	N. Y. Sporting Goods Co. .... 71	Veeder Mfg. Co. .... 97
Cleanola Co. .... 69	Hoffecker Co. .... 65	Nordyke & Marmon Co. .... 56	Warner Instrument Co. .... 81
Cleveland Motor Car Co. .... 96	Hoffman, Geo. W. .... 66	Northway Motor & Mfg. Co. .... 58	Watt-Detroit Carburetor Co. .... 86
Coes Wrench Co. .... 46	Holley Bros. Co. .... 58	Nuttall Co., R. D. .... 52	Wayne Automobile Co. .... 57
Colgan Co., J. W. .... 54	Holsman Automobile Co. .... 87	Oakland Motor Car Co. .... 107	Weeber Mfg. Works, C. F. .... 52
Comptor d'Innovations pour Automobiles ..... 76	Hopewell Bros. .... 51	Ofeldt & Sons. .... 66	Weed Chain Tire Grip Co. .... 67
Connecticut Steel & Wire Co. .... 80	Hotel Gilsey ..... 74	Olds Motor Works. .... 57	Welch Motor Car Co. .... 84
Conn. Tel. & Elec. Co. .... 93	Hotel Monmouth Beach. .... 74	Pacific Tucking & Mfg. Co. .... 51	Western Motor Co. .... 73
Continental Caoutchouc Co. .... 62	Hotel New Amsterdam ..... 74	Packard Electric Co. .... 58	Weston Elec. Instrument Co. .... 81
Continental Motor Mfg. Co. .... 69	Hotel Pierremont ..... 74	Packard Motor Car Co. .... 110	Wheeler & Schebler. .... 105
Cook's Sons, Adam. .... 77	Hotel Richmond ..... 74	Palmer & Singer Mfg. Co. .... 59	White Co., The. .... 108
Corbin Motor Vehicle Corp. .... 84	Hotel Tuller ..... 74	Farish & Bingham. .... 52	Whitney Mfg. Co. .... 79
Corcoran Lamp Co. .... 70	Howard Motor Works. .... 56	Parker, Stearns & Co. .... 73	Winton Motor Carriage Co. .... 112
Cornish-Friedburg Motor Car. .... 56	Hoyt Electrical Ins. Co. .... 87	Perfection Grease Co. .... 77	Wisconsin Tire Protector Co. .... 88
Correspondence School of Mo- tor Car Practice. .... 66	Hydraulic Pressed Steel Co. .... 52	Perkins-Campbell Co. .... 68	Witherbee Igniter Co. .... 90
Cotta, Chas. .... 58	Imperial Motor Car Co. .... 56	Peugeot Freres ..... 52	Wyman & Gordon Co. .... 50
	Indestructible Steel Wheel Co. .... 52	Pfanstiehl Elec. Laboratory. .... 66	York Motor Car Co. .... 57
	Isotta Import Co. .... 63	Picrome Hide Co. .... 52	
	Jackson Automobile Co. .... 56	Pierce Engine Co. .... 57	
	Jacobson Bros. .... 75	Pioneer Brass Works. .... 52	
		Pirelli & Co. .... 57	

FOR UNMATCHABLE QUALITY BUY

**COES**

STEEL HANDLE MODEL

**WRENCH**

91

**THE WRENCH for Automobilists**

High-grade quality in every detail of design, material, workmanship and up-to-date improvement. Excellence with extremely reasonable cost.

- NON-BREAKABLE CASTINGS
- NON-STRIPABLE THREADS
- NON-TROUBLESOME PARTS

**QUALITY**  
Through and Through.

Look for the name—COES



70 years splendid reputation worthy maintained right up to the present time as the World's Best Wrench Makers. Write for "Wrench Book" free.

**COES WRENCH CO., WORCESTER, MASS.**

# THE AUTOMOBILE

## HARRISBURG RUN'S BIG PRIZE WON BY A STEAMER

HARRISBURG, Pa., May 6.—At 2 o'clock this morning, after seven hours' hard work, the technical committee of the Motor Club of Harrisburg decided that the White, driven by Walter White, had won the Class A cup in the club's second annual endurance run with a perfect score. The win carries with it a victory in the run-off of last year's tie—the first double-headed triumph in the annals of automobiling. When the extremely critical examination is taken into consideration, the victory is all the more creditable.

Before arriving at their verdict, each of the even-score cars turned over to the committee was tested on a nearby hill for brake efficiency; clutches were tested by putting front wheels against a high curb to see if the rear wheels would spin; both ignition systems were gone over; transmissions were tried for defects in gear working; every wheel, axle, spring, frame, motor, and gear-set was examined; every bolt, nut, and pin was gone

over. Nothing was overlooked. The car that survived such a critical test deserved a victory, be its road demerits ever so many. As a matter of fact, they were few and far between.

In the big runabout class the Pullman went through the exacting scrutiny with the smallest number of penalty points, and Harry Croninger's Pennsylvania had only five points more.

The committee were so tired after cleaning up Classes A and C that they knocked off for the night, and will finish after breakfast.

The figures for the two days, as far as completed, are:

### Class A—Touring Cars Costing \$2,250 and Over.

No.	Car	H.P.	Driver	Road Pen.	Tech. Pen.	Total
28	White .....	30	Walter White.....	0	0	0
18	Thomas .....	60	Fred Moselein.....	0	15	15
5	Pullman .....	40	Robert Morton.....	65	0	65
10	Stoddard-Dayton.....	45	R. Shirk.....	69	0	69



General View in Reading, Where the Contestants Checked on the First Day of the Endurance Run.

**Class C—Runabouts Costing \$2,000 and Over.**

No.	Car	H.P.	Driver	Road Pen.	Tech. Pen.	Total
8	Pullman	40	Stuart Lafean	0	6	6
27	Pennsylvania	50	R. H. Croninger	0	11	11
25	Rambler	32	A. H. Bitner	0	17	17
17	Apperson	50	C. J. Swain	13	5	18
4	Pullman	40	E. G. Irvin	9	51	60

The observers' reports showed that the penalties accumulated by cars of Classes B and D for work on the road, engine stops, and breaking seals on those cars turned over to the technical committee are as follows:

**Class B—Touring Cars Costing Less Than \$2,250.**

No.	Car	H.P.	Driver	Cause	Points
19	Maxwell	24	Charles Fleming	Oiling.	2
21	Maxwell	20	Andrew Bender	Adjusting oiler.	2
23	Cadillac	20-25	C. C. Crispen	Broken spring.	4
6	Pullman	20	Max Graupner	Oiling, 6; spark plugs, 8; seals, 5.	19

**Class D—Runabouts Costing Under \$2,000.**

No.	Car	H.P.	Driver	Cause	Points
12	Pullman	20	C. C. Cumbler		0
20	Maxwell	20	John Sellers		0
22	Mitchell	35	W. M. Cram		0
9	Pullman	20	C. C. Cocklin	Oiling, 10; fender, 10; battery, 4; seals, 5.	29
24	Ford	15-18	A. A. Jones	Ignition, 70; stop, 158; seals, 15.	243

The checkers' figures have not as yet been analyzed, and some of the above cars will have a few more points chalked up against



Walter White at Wheel of Steam Winner.

them for lateness at controls, but, generally speaking, few of the contestants suffered from this cause. Four cars were not turned over to the technical committee, and these also will have to be added.

**What Happened on the First Day.**

PHILADELPHIA, May 4.—The first day's summing up of the performances of the twenty-six cars that started this morning in the two-day endurance run of the Motor Club of Harrisburg shows that eleven have clean scores up to date. Five others are in a mix-up with the checker at Easton, his records showing that they checked in ahead of time. The matter is in abeyance, and the quintet may satisfy the contest committee that they did not fracture the rules. All but one of the twenty-six cars are still in the run, the Stoddard-Dayton, driven by Howard Hodson, having been put *hors de combat* by smashing up while coming into Doylestown.

Among the immaculates up to date are three Class A's, two B's, four C's, and two D's, the latter pair being J. S. Trego's Jackson and A. A. Jones' Ford. These little fellows performed their task like veterans, and asked no favors of their high-powered rivals. Arthur Kumpf and Walter White are still clean, and will bend every effort to capture the 1907 cup, which was tied up with four clean scores. One of these did not start, the other, the Pullman, driven by "Bob" Morton, collected sixty-one bad marks on the road to-day.

The start was made at 7:30, under a leaden sky, which spat rain at intervals and drove the travelers to oilskins and rubber coats. It was but a flash in the pan, however, and the weather man handed out a fair article, barring the bleak southeast wind, which persisted throughout the day. Road conditions were as good as they can be over the route selected, lots of alleged road repairing being in progress for miles out of Harrisburg, which "dragged" the contestants badly. The eighty minutes proved more than enough, however, to allow all but C. C. Cocklin's Pullman No. 9 to get under cover of the Lebanon control safely. A broken water connection delayed him twenty-five minutes. After that it was well within the powers of an average car and driver to make the controls, even the much-dreaded Reading-Allentown leg and the Easton-Doylestown, which proved fatal to the hopes of so many Quakers last New Year's Day, being negotiated with ease by the majority of the cars. The schedule was liberally sprinkled with "danger" warnings all along the two controls, but nothing untoward happened until A. J. Hamilton's Stoddard-Dayton No. 11 skidded on rounding a curve, and was temporarily put out of the running. Neither Hamilton nor his driver, Howard Hudson, was hurt.

Tire troubles were not unreasonably frequent during the run, the greatest sufferer in this respect being the 1905 Franklin-20, which the Central Pennsylvania Automobile Company loaned the committee for the purpose. Fully a dozen punctures were suffered by the pressmen's car, and it fell so far behind that it became necessary to cut the course, running direct from Reading to Philadelphia, and at that the car was not garaged until after 6:30.

The first car to show up at to-day's finish was E. G. Irvin's Class C Pullman, which arrived at the White garage on the dot at 4 o'clock, twenty minutes ahead of time. J. S. Trego's Class D Jackson followed a few minutes later, and then there was an interval of ten minutes before another car materialized, but it was the head of a procession. By 4:30 the majority of the cars were in the control, waiting to be checked out. They are under lock and key to-night, guarded by special watchmen.

Following is the schedule, showing the distances and time allowances for the first day:

	Distance	Total Distance	TIME
Harrisburg to Lebanon	26.4	26.4	1:30:00
Lebanon to Reading	29.8	56.2	1:30:00
Reading to Allentown	37	93.2	1:50:00
Allentown to Easton	23	116.2	1:10:00
Easton to Doylestown	32.4	148.6	1:35:00
Doylestown to Philadelphia	26.1	174.7	1:25:00

The controls for the first day were established at the *Patriot* office, Harrisburg; the Eagle House, Lebanon; Mansion House, Reading; Allen House, Allentown; Soldiers' Monument, Easton; Monument House, Doylestown, and the White garage, Philadelphia.

**Makers Considered Run Most Important.**

That the manufacturers were "hep" to the advertising value of a win in this run was manifest by the array of crack drivers who lined up for the contest. In Class A there were Walter White; Arthur Kumpf, who drove Herbert F. Rawll's Pierce Great Arrow, and won his spurs in last year's Glidden, being the youngest driver on that tour, and Robert Morton, who won the Philadelphia-Savannah race in his Pullman against the Studebaker. White, Kumpf, and Morton were the three double-prize drivers. "Bob" Shirk, who drove the Stoddard-Dayton, has registered many wins. Charlie Fleming came on from the Tarrytown factory to drive Andrew Redmond's Maxwell in Class B. Harry Croninger, general manager of the Pennsylvania Automobile Company, drove his Pennsylvania in Class C. A. H. Bitner, a Rambler crack, who scores frequently, was at the wheel of one of the Ramblers in the same class.

The rules provided for four classes—A, touring cars catalogued at \$2,250 and over; B, touring cars under \$2,250; C, runabouts catalogued at \$2,000 and over; D, runabouts under \$2,000.

An interesting feature of the run was the fierce fight in Class A to win last year's cup, which was held up by the committee

owing to the four clean scorers being unable to come to an agreement as to its final disposition. It will be recalled that the contest committee on that occasion decided to have the run-off take place this year, and all four promised to enter. All but one did so—Walter White's White steamer, E. G. Irvin's Pullman, and Herbert F. Rawll's Pierce Great Arrow showing up at the start, the Thomas of S. K. Hamburger being the only absentee of the quartet, he having waived his claim to the cup.

The official cars made quite a respectable show by themselves. There were no less than eight of them, including Referee R. H. Johnston's White; O. C. Robertson's White, pilot; H. P. Young's Franklin, first patrol; H. M. Cumber's Pullman, second patrol; Central Pennsylvania Automobile Company's Franklin, press; H. A. Moyer's Rambler, H. C. Wright's Maxwell, and the Harrisburg Automobile Company's Stanley steamer, officials' cars.

All the contestants were required to report at the Keystone Garage, Harrisburg, between 3 and 8 p. m., Sunday, where they were sealed and placed under guard until the start.

The Harrisburgers are boosting Beecroft as an up-to-the-handle technical committeeman. When he arrived at the State capital at 1 o'clock Sunday afternoon, he found that none of his confreres had reported. He didn't wait for them, but annexed a jumper and a pair of overalls and climbed in, over, around, through, and under every car turned in by a competitor, making note of all defects and shortcomings. He was on the job until long after midnight, the other committeemen having turned up later and helped him out a little. Up bright and early in the morning, he gave each car a supplementary examination, noting wheel alignments, listening to cylinder popping, and "getting on" to anything he may have overlooked the night before. Beecroft was surely a revelation to the Harrisburgers.

**Details of the Second Day.**

HARRISBURG, PA., May 5.—The conditions to-day were even better than yesterday, a bright sun, tempered by a cool breeze, making the sport more of a pleasure party. The schedule was a trifle fast for some of the smaller fellows, but unless in case of accident, the 20-miles-an-hour limit, on which it was based, proved not too severe.

When the twenty-four remaining cars checked out of the White garage in Philadelphia there was a great scurrying for gasoline, while the rapid clank of tire tools was evident on all sides. It was a case of rush, for all time consumed in these necessary operations came out of the seventy-five minutes allowed to cover the 22.2 miles to Norristown. The quick work of the contestants was marveled at by a crowd of several thousand persons, which had to be kept in place by the police.

Poor police arrangements were the cause of an accident in the Reading control to-day. Cars Nos. 1 and 3 were moving to the front to take the word. They were traveling at a gait not faster than 10 miles an hour when an eighty-year-old man, one of a crowd of a thousand or more which blocked the street in front of the Mansion House, was knocked down, and, it is said, seriously injured. The drivers, R. H. Hagerling and Chester Smith, were arrested, but later released when they put up a cash bond. Neither car had clean-scored yesterday and the mix-up with the authorities, which netted them disqualification according to the rules, did not affect their standing.

The Stoddard-Dayton entries, which created such a furore here last year, had extremely hard luck. The Class C car was put out yesterday by a smashed wheel, and to-day "Bob" Shirk could not get the motor going on the Class A entry. He fumed and sweated at the White garage for a trifle over an hour after being given the word, but when he got going he drove to such purpose that at Reading, sixty miles, he was only five minutes behind his schedule. The remaining controls he negotiated ahead of time.

Several clean scores of yesterday were eliminated to-day, chief among which was the Pierce Arrow, driven by Arthur Kumpf. Just after leaving Columbia the Arrow's differential broke, penalizing it both on road and technical bases, and leaving the White sole clean-scorer in the triangular fight for the 1907 cup. Every-

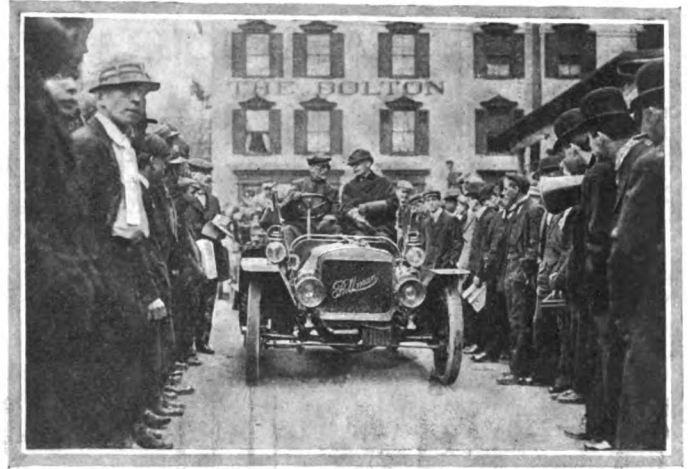

J. A. Kilne's Pullman, Which Scored in Big Runabouts.

body was pulling for the Arrow, for it carried the only lady on the run—Miss Anita Baker, of Harrisburg.

No. 23, S. Thorley's Class B Cadillac, went into the road penalty column through the medium of a broken spring. No. 2, J. S. Trego's Jackson, lost its "o" when the ring locking its left rear tire snapped and went flying into the field at the side of the road. Trego sent back eleven miles to Philadelphia for a new one and came in through the rain long after the officials had gone to supper. A. A. Jones' little Ford developed battery troubles while yet within the Philadelphia limits, and lost an hour ere a 'phone message brought him relief. He "beat it" in pursuit of the run after getting things straightened out, and reported at the finish five minutes ahead of time.

E. G. Irvin's big Class C Pullman, No. 4, which was the first car into every control on both days, and had a clean road score all but made, fell from grace ten miles from the home stake. The hose connecting the water jacket and cooler slipped off, and the engine began to heat up. To get at the trouble it became necessary to break the seal and raise the bonnet.

The mix-up yesterday at Easton over the checker having ordered four of the contestants off before their scheduled time was ignored by the committee, and the demerits tacked on the Stoddard-Dayton for opening the hood to oil the cylinders were removed. The schedule showing second day's run follows:

	Dist.	Total Dist.	Time
Philadelphia to Norristown.....	22.2		1:15
Norristown to Reading.....	37.8	60	1:45
Reading to Lancaster.....	33.6	93.6	1:35
Lancaster to Mount Joy.....	25.1	118.7	1:15
Mount Joy to Harrisburg.....	24	142.7	1:10

The intermediate controls were at the Hotel Montgomery, Norristown; Mansion House, Reading; County National Bank, Lancaster, and Washington House, Mount Joy.

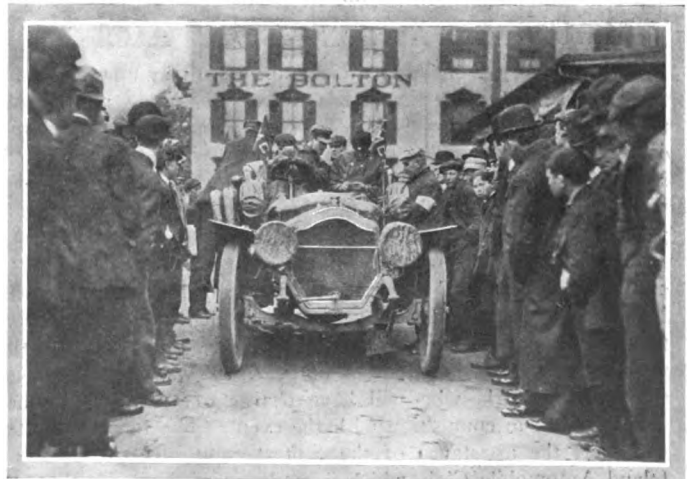

Thomas Flyer, Second in Big Touring Car Class.



## A. A. A. TOUR PATHFINDER ON THE WAY

**B**UFFALO, May 4.—The pathfinder in the annual endurance contest of the American Automobile Association for Glidden trophy and Hower trophy for runabouts left Buffalo last Friday to blaze the trail between Buffalo and Saratoga Springs, after the roundabout journey which will cover the 1908 route. The machine is a 50-horsepower Premier, and carried this inscription on the hood, "Official Pathfinder 1908, A. A. A. Tour." When the car left this city it carried Dai H. Lewis, secretary of



Official A. A. A. Premier Pathfinder Leaving Buffalo.

the touring board, who is the official mapper; Ray McNamara, driver; Leon M. Bradley, of the A. M. C. M. A., and photographer Lazarnick.

Mr. Lewis said he expected to have the route completely planned within three weeks. He anticipates some rough places, but is of the opinion that this year's route will not call for so many severe trials as have bothered the drivers in the Glidden tours of the past. It is the expectation that some better roads will be met. Secretary Lewis' car will be the confetti car to

head the tour, which will start from this city July 9. Mr. Lewis achieved an excellent reputation in this capacity last year.

### Pathfinders Sidestep Philadelphia.

**PITTSBURG, May 4.**—Secretary Dai H. Lewis, of the A. A. A. Touring Board, and his associate pathfinders, have completed their task of laying out the route of the annual reliability test from Buffalo as far as this city. They have tarried here several days, wrestling with the problem of how to include Philadelphia in the route and at the same time cut out from the itinerary every foot of the unfriendly soil of New Jersey. The pathfinders have so far proved unequal to the solution of the problem, and have practically determined to give the City of Brotherly Love the go-by. Accordingly, they propose to lay their course to Bedford Springs, via Export and Blairsville, which will cut out the run over the National turnpike by way of Greensburg, originally contemplated. From Bedford Springs, they plan to go to Harrisburg, and then cut across Northeastern Pennsylvania to Albany, then down the east bank of the Hudson river to New York City. From New York, it is the intention to partially retrace their tracks, and strike east into New England, to Boston, whence they will reach the terminus of the run at Saratoga, touring a part of the White Mountain district en route.

[The pathfinders should do a lot of figuring, and think many more times than twice, before sidestepping Philadelphia, one of the greatest automobile centers in the country, and the home of one of the largest and most loyal A. A. A. clubs. R. H. Johnston recently laid out a two-days' run of 225 miles between Philadelphia and New York, which took in the Delaware Water Gap, and dodged New Jersey utterly. Following this route, there would be a ninety-mile run to the Gap, where three big hotels would afford accommodation over night. This would leave for the morrow a 135-mile run to New York by way of Port Jervis and the ferry to Tarrytown at Nyack.—Ed.]

### A. M. C. M. A. MAY JOIN CHICAGO CLUB IN SHOW.

**CHICAGO, May 4.**—The board of managers of the Chicago Automobile Club will meet Thursday to consider a letter from Alfred Reeves, general manager of the American Motor Car Manufacturers' Association, in which the writer intimates that the independents would not be at all averse to joining forces with the local clubs and promoting a second big show in Chicago next winter. Mr. Reeves asks the club what it could furnish in the buildings line, and adds there is little likelihood of the traveling show being run in the fall because of lack of time.

### STRAIGHTAWAY LONG ISLAND RACING.

There is every promise of a big and noteworthy meet evolving from the straightaway time trials to be run June 5 on Hillside avenue, Jamaica, Long Island, in connection with the subway opening celebration. The three-mile course will be oiled, fenced, and guarded by police. The contests, which will all be speed trials, will begin at 1 o'clock and be preceded by an automobile parade starting two hours earlier.

The meet will be in charge of the automobile race committee of the Long Island subway celebration committee, of which John Niederstein, County Clerk for Queens, is chairman. The secretary of the committee is Joseph M. Gray, Jamaica, and the assistant secretary is Fred J. Wagner, 29 West Forty-second street, New York, who will have charge of entries and other general work in connection with the event. The race committee will have the assistance of the contest committee of the Long Island Automobile Club, which is made up of A. R. Pardington, chairman; F. D. Bandell, C. G. Arnold, and Russell A. Field, secretary.

### WOMEN TO BE TRANSCONTINENTALISTS.

There have been all kinds of transcontinental auto trips in the past few years, but it has remained for Mrs. E. E. Teape and Mrs. Vera McKelvie, her daughter, of Sand Point, Idaho, to be the first women to undertake the 4,000 miles intervening between Portland, Me., and Portland, Ore. They will leave Portland, Me., May 14, unhampered by assistants or luggage other than the necessary wearing apparel, and will make the trip with a Waltham-Orient by easy stages, going via Boston, Albany, Buffalo, Chicago, Des Moines, Omaha, Cheyenne, Salt Lake City, Ogden, Boise, and Baker City to Portland.

Mrs. Teape is now in New York City, arranging for the details of this longest trip ever undertaken by women autoists, and is quite confident that she and her daughter will not only make the trip successfully, but she has mapped out a schedule which should land them on the Pacific Coast at the end of eight weeks. This is considered remarkable, in view of the difficulties encountered by the New York-Paris contestants, though the women drivers will not be hampered by snow and ice. But that Mrs. Teape knows the country and how to cover it, is evident from the fact that she drove a 4-horsepower Waltham buckboard from Chicago to Denver last year in two weeks.

"I am enthusiastic regarding the trip," said Mrs. Teape, when seen at her hotel, "and I feel sure we can make it successfully. I realize the difficulties that two women may encounter, but we have always lived in the West and have plenty of confidence in our ability to overcome every one of the trials and obstacles that may beset us on the long trip. We shall not be bothered with extra equipment or baggage to hamper us, for, as some one has very wisely said, 'the greatest hampers to motorists are the hampers they carry with them.'"

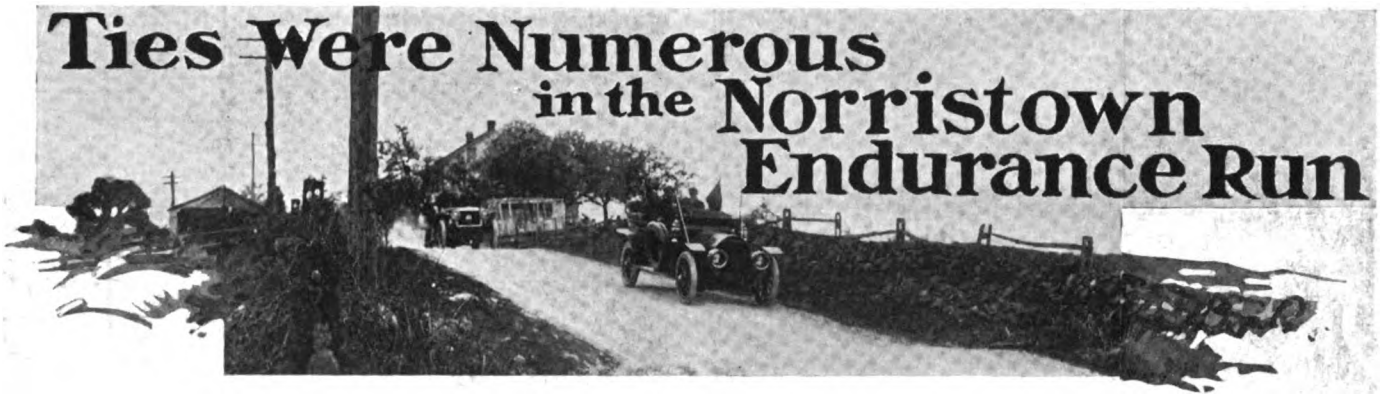

Archie Hughes and His General Utility Pierce Great Arrow Showing the Way, Followed by J. E. Mountain's Clean Score Winton.

**N**ORRISTOWN, PA., May 2.—Nearly 50 per cent. of clean-score cars—15 out of 32 official starters—tells the story of last Tuesday's initial endurance run of the Norristown Automobile Club. The road conditions were ideal and the schedule a trifle too easy for a vital test of the relative merits of the cream of the American automobile industry. Yet the very ease of the going was an inducement to speed which subjected all the cars to a severe pounding over the thank-you-ma'am roads of Montgomery and Lancaster counties. That such a large proportion came through without a semblance of a cause for the imposition of demerits, speaks volumes for the sturdiness of the American product. The redundancy of clean scores proved a thorn in the sides of the contest committee, which, at a meeting Friday night to consider the situation, at which the bulk of the clean-score entrants were present, it was decided not to have a run-off, as originally intended, but to melt down the handsome cup and strike off medals, to be given to each of the successful entrants and drivers.

The contest committee tried a scheme to block the usual piling up process at controls, and it worked like a charm. They adopted a rule which read: "Between checking stations each car may stop for a total elapsed time of five minutes, and no more, without penalization, provided no repairs or adjustments of any kind whatsoever (except replenishment of supplies) are made during the elapsed time." The result was that each driver had to have a coach, who, watch in hand, hauled him up when he neared a control ahead of time. It was a novel sight to see a dozen or more cars loafing along in an effort to consume time. As a result most of the cars came up to the mark and were sent away again within a very few minutes, and at no control except that at Lancaster were more than three or four cars to be seen at any one time. At the last-mentioned place the schedule called for a two-hour dinner stop, the first car being sent away on the afternoon lap at 1 o'clock sharp.

Some other novelties in the rules were those allowing but one man at a time on a repair job; prohibiting the stopping of motors at intermediate controls (excepting the dinner stop); and the covering and sealing of speedometers. Checking stations were established at the start and finish at the Hotel Montgomery, Norristown; Stephen House, Coatesville; Wheatland House, Lancaster; Mansion House, Reading, and at the Schuler House, Pottstown.

The route led through the Pennsylvania Dunkard country, and, when the cars began to skin through a town, the brethren and sisters were prop-

erly excited, and knocked off work to a man and woman until the last car had passed. And perhaps some of those sanctimonious-looking brothers aren't motor-wise! It was really startling to hear the bunch at Ephrata shout out: "Here comes a Pullman!" "There's a Pierce Arrow!" "That one that just passed was a Pope-Toledo!" It's safe betting that not a Dunkard in the entire section owns a car, but they know 'em when they see 'em just the same.

The press people had the time of their lives. They were consigned to the care of Archie Hughes, of Glidden tour fame, who kindly offered the services of himself and his big Pierce Great Arrow Six to the committee. Starting from Norristown among the last, Archie took upon himself the task of Good Samaritan, first-aid-to-the-injured, and general all-around errand boy. When the driver of car No. 1 was put down and out by a side-swipe from No. 3 while engaged in fixing a puncture, Hughes was on the job instant, and, after helping to get the injured man on his car again, he ran back to the railroad station to pick up a member of No. 1's party, who had gone to telephoning for a physician. Articles dropped on the road by the hurrying contestants were retrieved by the press contingent, who readily entered into the spirit of the self-sacrificing game. When No. 5's commutator went to the bad, Archie happened along a few minutes later, and, after helping to fix the stalled car comfortably for the night, he piled the careless folk in among the pressmen's legs and brought them home. And, notwithstanding the numerous self-imposed delays, all the controls were negotiated by the Pierce Arrow well within the official schedule.

Of course, there were hard-luck stories. One of the most

**OFFICIAL TABULATED RESULTS OF THE NORRISTOWN ENDURANCE RUN.**

No.	Car and Model	H.P.	Entrant	Driver	Penalties		
					Road	Mech.	Total
2	Maxwell, 1908 D.....	28	Kelsey Motor Car Co..	W. M. David.....	0	0	0
6	Reo, 1908 A.....	20	D. F. Templeton, Jr...	D. F. Templeton....	0	0	0
8	Cadillac, 1907.....	30	J. Elwood Lee.....	J. Elwood Lee.....	0	0	0
9	Mitchell, 1908 H.....	20	B. F. Stritzinger.....	B. F. Stritzinger...	0	0	0
10	Buick, 1908 F.....	22	Charles W. Mann.....	C. W. Mann.....	0	0	0
11	Stoddard-Dayton, 1907 F...	35	F. B. Wildman.....	F. B. Wildman.....	0	0	0
14	Maxwell, 1906.....	40	Kelsey Motor Car Co..	W. C. Longstreth...	0	0	0
17	Reo, 1908 A.....	20	H. A. Wilson.....	J. A. Beideman.....	0	0	0
20	Winton, 1906 K.....	30	J. E. Mountain.....	J. E. Mountain.....	0	0	0
21	Mitchell, 1908 H.....	20	R. A. Jackson.....	R. A. Jackson.....	0	0	0
26	Ford, 1908.....	16	Ford Motor Co.....	Jos. F. Graham....	0	0	0
28	Rambler, 1908, 34.....	32	T. B. Jeffery & Co.....	A. H. Bitner.....	0	0	0
29	Rambler, 1908, 34.....	32	Brown Auto Top Co.....	Ira L. Brown.....	0	0	0
35	Premier, 1908.....	30	Norris City Garage.....	R. F. McNamara....	0	0	0
36	Apperson, 1908.....	30	Phila. Auto Co.....	E. C. Benson.....	0	0	0
16	Maxwell, 1908 LC.....	14	Kelsey Motor Car Co..	J. R. Lott.....	1	0	1
32	Buick, 1908 S.....	26	E. H. Lewis.....	E. H. Lewis.....	0	3	3
22	Mitchell, 1908 G.....	20	Walter Cram.....	Walter Cram.....	6	0	6
3	*Packard, 1908.....	30	Mrs. M. S. Lees.....	Van Peacock.....	11	0	11
12	Locomobile, 1905 E.....	20	Jos. R. Coulston.....	J. R. Coulston.....	0	11	11
24	Mitchell, 1908 I.....	35	Walter Cram.....	H. Greenwalt.....	13	0	13
33	Pope-Toledo, 1906.....	35	George L. Taubel.....	G. L. Taubel.....	0	14	14
31	Pennsylvania, 1908 C.....	60	H. S. Stillwagon.....	R. H. Croninger....	16	0	16
1	Crawford, 1906.....	28	F. M. Jaquith.....	F. M. Jaquith.....	19	10	28
15	Maxwell, 1907 RL.....	14	Kelsey Motor Car Co..	W. P. David.....	10	19	29
18	†Pierce Great Arrow, 1907...	45	R. V. Hoy.....	P. V. Hoy.....	53	0	53
34	National, 1905.....	40	Christopher Cox.....	Harry C. Cox.....	181	10	191
5	Franklin, 1905 E.....	12	S. E. Ballard.....	S. E. Ballard.....	Did	Not	Finish
25	Reo, 1907 A.....	16	F. Leichthammer.....	F. Leichthammer...	"	"	"
27	Crawford, 1908 D.....	40	T. M. Twining.....	T. W. Twining.....	"	"	"
30	Acme, 1908.....	30	John L. Schull.....	Malin Leinan.....	"	"	"

\*Originally returned clean-score, but was protested for stopping motor after accident with driver of No. 1. Protest sustained.  
 †Excessive road penalty due to observer's misunderstanding of rules.

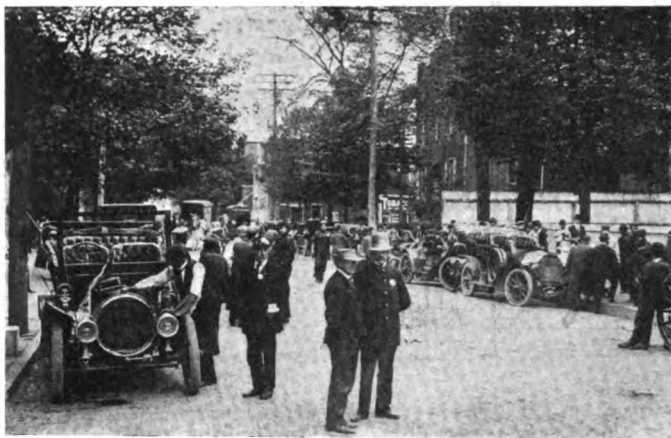

At the Lancaster Control, In Front of the Wheatland House.



The Stop at the Official Control, Manalton House, Reading.

heart-breaking experiences was that of S. E. Ballard, who cleaned his Franklin-12 till almost within sight of home, when his commutator went to the bad, and the car had to be abandoned. R. A. Jackson, who drove No. 21, a Mitchell, dropped his license tag in the road, and suffered two demerits when he stopped his car to rescue it. They were, however, lifted afterward by the committee. While entering West Reading, Martin

Leinan, driving No. 30, a 30-horsepower Acme, skidded at a sharp turn and plunged up the bank into a three-rail fence, breaking a front wheel off clean. Thus another clean score went a-glimmering. Reading is the Acme's home town, however, and a 'phone message soon brought assistance from the factory, and the wrecked car was towed there and repaired. It resumed its journey at 6 o'clock and reported at the finish about 8 o'clock.

## DE DION SAID TO HAVE HAD ENOUGH OF ROUND-THE-WORLD

ACCORDING to a cable from Paris to the *New York Times*, the only French car now remaining in the New York-Paris contest will probably be withdrawn on its arrival at Vladivostok, instead of continuing through Siberia, in accordance with the recent change of plans. This is the De Dion, which is now in Japan, en route to Vladivostok, and it is understood that it will not continue the race from that point. A declaration is expected to this effect from Marquis De Dion. This will leave the Thomas, Zust, and Protos to continue across Siberia. As things stand at present, the French and Italian cars are in Japan and are expected to reach Vladivostok this week; the Thomas is on the *Shawmut*, due to arrive at Yokohama May 8, and will probably reach Vladivostok May 12 or 13, while the German Protos

car is on the *General Logan*, bound direct for Vladivostok, and is expected to reach there on or before May 15.

It is expected that a time allowance plan will be worked out in order that the three cars in question may continue the race. The Thomas, which will be in charge of George Schuster, will be allowed the time it led the Zust when it reached Seattle, the furthest point mutually reached by the two cars on the original route. It is understood that the Protos will not be disqualified as the result of having been shipped from Ogden to Seattle, but will be handicapped the amount it was behind the Thomas at Ogden, as well as the time consumed in running from Ogden to San Francisco by the latter. No official decision has been announced as yet, but it is thought that this step will be taken.

## AUTO SPORT TO AND IN THE DELAWARE GAP

PHILADELPHIA, May 3.—The *Public Ledger* of this city is interested in a four days' auto carnival which will be held in the Pocono region during the last week in June. To carry out the project an organization known as the Monroe County Automobile Association has been formed, with Dr. C. M. Brownell as president and A. F. Everitt, of Stroudsburg, Pa., as secretary. The object of the carnival is the exploiting of that beautiful mountain region with a view of attracting there the automobile element, not alone of Philadelphia, but of New York as well. Certainly there are no more charming spots within five hours' ride of either city than the Pocono region affords; nor better roads; nor better nor more numerous hotels.

To attract the denizens of the big cities, the new association has proposed this four days' carnival, which will begin with a sealed hood reliability run, starting from New York and Philadelphia simultaneously, and winding up at Stroudsburg. The second day will be taken up with a hill climb for numerous classes over a stiffish hill the committee has in mind overlooking the picturesque Delaware Water Gap. For the third day there will be short distance climb trials over a perfect stretch of road near Mount Pocomo, with a mile for getting up speed and an equal

length of road beyond the finish—a bit of road which, given the machines, will produce world's records. A gymkhana, with all the stunts such affairs bring forth, will make up the final day's program. This will be held on a half-mile track outside of Stroudsburg, which town will be during the week the center whence the visitors will radiate to get to the spots where the various events are to be held.

Allied with the Pennsylvania Motor Federation, and hence with the A. A. A., the Poconoers will do everything officially and up to the handle. Committees are already at work, support has been assured, many factory people and agency managers have been interested already, and prospects seem good for a most successful carnival.

### WILKES-BARRE CLUB POSTING SIGNS.

WILKES-BARRE, PA., May 4.—There are so many winding roads around this city, and so few of them are familiar to visiting motorists that the Wilkes-Barre Automobile Club has just undertaken the task of marking them with sign posts within a radius of fifty miles. Both directions and distances will be given.



Thomas-Forty Trio of Clean-score Performers in Detroit Trade Association's 450-mile Endurance Run.

## THIRTEEN CLEAN SCORES IN DETROIT'S THREE-DAY RUN

**D**ETROIT, May 4.—With the three days' endurance run just completed still fresh in mind, the Detroit Automobile Dealers' Association is seriously considering holding a non-stop contest over the same course in the near future. Enthusiasm runs high among those who took part in the endurance run, nearly, if not all of whom would be entrants in the event of a non-stop race. Other well-known drivers have expressed a willingness to enter, and the success of such an undertaking seems assured.

Last week's three-day gruelling contest provided some good sport, and likewise proved a revelation in several respects. The course was triangular, with Saginaw as the first day's destination, Kalamazoo the second, and the return to Detroit occupying the third, the entire distance traversed being 419 miles. Thirty-two cars, ranging all the way from a Brush runabout and a single-cylinder Cadillac up to the ponderous six-cylinder, were entered, and of this number thirteen finished with a perfect score, four others having less than ten points marked against them. Not the least satisfactory feature of the contest was the showing made by the light cars. The absence of perfect scores in this class does not accurately reflect conditions, penalization in nearly every instance being clearly traceable to the fault of drivers and not to mechanical defects. As was expected, many of the heavy cars romped through the course with time to spare, although at numerous points careful driving was necessary.

The roads in spots were abominable, and rain and snow, accompanied by a biting wind, added to the general discomfort. West of Saginaw fifteen miles of the worst roads imaginable were encountered, and here numerous penalizations occurred. A Cadillac touring car, while leading the procession through a quagmire, with mud and water hub deep, suddenly struck a buried tree lying horizontally across the road. After a struggle, the front wheels were forced over this, only to strike another log. Then a third was encountered and surmounted, but a buried stump

standing upright proved the undoing of the car so far as a perfect score was concerned. As the car plunged into the mud after hurdling one of these logs one of the parallel steering rods hit squarely on top of the stump, being bent out of all shape, and necessitating putting in a new one. With water five feet deep on either side, a long string of cars was held up for an hour while repairs were made.

The incident furnished a little excitement that was not on the regular program, the Thomas "Snowbird" making the course on high gear as a non-contestant, deciding to take to the railroad track and avoid delay. Hardly had the track been gained when a passenger train rushed down from the rear. For a mile there was a lively race between the steam and motor cars, the "Snowbird" reaching a crossing and safety just a nose ahead of the locomotive.

A Cadillac runabout gave an exhibition of running power that was unique. On the second day out it struck an imbedded stone, tearing out both brakes and putting the low gears out of commission. Then followed a performance that would put a crab to shame. Every time a hill was encountered the car was turned around and backed to the top, made another turn and continued on its course. The absence of brakes made this a ticklish proposition, but it was safely accomplished a dozen times, the car finishing with a score of 995 points.

If it answered no other purpose, the endurance run would have been worth while because of the boost given the good roads movement. Much of the course was good, but there were long stretches where the highways were rendered well nigh impassable by spring rains, and where a course had to be picked through mire in many cases hub deep. Farmers along the road displayed a keen interest in the event, and were, as a rule, friendly, one exception being a weazened old ruralite who, armed with an ancient shotgun, mounted the fence and announced his determination of shooting the first man who killed one of his chickens.



Northern Participants in Detroit Endurance Run—Two Were Two-cylinders and One a Four-cylinder.



Three opportunities were afforded, but the old man proved a poor marksman, and the motorists escaped unscathed.

Owing to the number of perfect scores, the silver loving cup offered will remain in the possession of the Detroit Automobile Dealers' Association, the names of those with perfect scores being engraved thereon. The entries and points scored are as follows:

No.	Car	Driver	Points
8	Franklin	Davis	1,000
9	Thomas	Grant	1,000
14	Peerless	Bemb	1,000
15	Northern	Chapin (E. J.)	1,000
19	Maxwell	Kelsey	1,000
20	Thomas	Mocheaky	1,000
23	White	Sheridan	1,000
26	Northern	House	1,000
27	Pierce-Arrow	Day	1,000
28	Oldsmobile	Aubel	1,000
30	Stoddard-Dayton	Lane	1,000
31	Thomas	Lorimer	1,000
32	Oldsmobile	Crum	1,000
5	Cadillac	White	999
16	Northern	Chapin (E. H.)	999
11	Stevens-Duryea	Schuffield	996
29	Cadillac	McMullen	995
22	Cadillac	Lemmer	992
12	Ford	Scott	989
21	Welch	Neumann	989
3	Pope-Hartford	Houston	986
18	Stevens-Duryea	Young	981
24	Ford	Cunningham	947
4	Cadillac	Garland	939
7	Brush	Mandell	813
6	Cadillac	Miloch	725
17	Maxwell	Bleasdale	688
25	Jackson	Schleffer	618
18	Mitchell	Gilmour	464
1	Jackson	Siedler	Disq.
2	Brush	Lobdell	Out
10	Jackson	McCalmount	Out

**FIVE MILE SPRINTS ONLY AT BOSTON.**

BOSTON, May 5.—Preliminary announcement of the events to be contested at the annual Memorial Day meet of the Bay State Automobile Association, to be held at Readville track, gives promise of some interesting sport. With one exception the races are all at five miles, it being the idea of the committee to provide snappy racing with close finishes. There are seven events in all, five for automobiles and two for motorcycles. The automobile events are as follows:

1. Five miles, open to stock gasoline touring cars, from 24.1 to 40 horsepower.
2. Five miles, open to stock gasoline touring cars from 40.1 to 60 horsepower.
3. Five miles, open to all gasoline runabouts irrespective of horsepower.
4. Twenty miles, open to stripped stock chasses.
5. Five-mile handicap.

The motorcycle events are: 1. Five miles, open to single-cylinder machines. 2. Five miles, free-for-all.

The committee considered the question of holding a twenty-four-hour race or some long-drawn-out contest, but decided that a more successful meeting could be held if the events were made short.

S. L. Haynes, of the Springfield Automobile Club, has been appointed referee by the racing committee, which consists of Harry W. Knights, Massachusetts member of the A. A. A. racing board; Charles E. Fay, manager of the Ford branch, and John L. Snow, manager of the Peerless branch. The entry blanks are being prepared and will be sent out this coming week.

**SEVENTEEN PERFECTLY SURVIVE MARYLAND ENDURANCE RUN**

BALTIMORE, May 4.—The first sealed bonnet contest to be held in Maryland took place last Saturday, and seventeen of the thirty-four cars entered completed the trip with perfect scores. The owners of each of these cars will receive as prizes handsome silver cups from the Baltimore News, under whose auspices, together with the Automobile Club of Maryland and the Baltimore Dealers' Association, the contest was held. The route was from Baltimore to Hagerstown, through the Blue Ridge mountains and over the roughest roads within the State, and return, a distance of 147.8 miles. In order to have a perfect score, it was necessary for the cars to complete the trip within twelve hours, without making any repairs otherwise than to the tires.

The first car started promptly at 6:30 o'clock Saturday morning, and was followed by the other cars at intervals of one minute apart. The cars that did not finish within the scheduled time returned either with broken cranks, seals, springs, rods, axles, etc. The Packard-30, driven by W. E. Baker, had to make seven changes of tires, while the Thomas-40, driven by W. H. Gill, made two such changes. In making one of these changes in the mountains, while pulling a steep grade, the Thomas narrowly escaped colliding with the Oldsmobile, driven by A. L. McCormick, which stopped suddenly on the grade and started to descend the hill. A slight collision occurred between a Mary-

land-26 and a Thomas-60 car at Flint Station, on the Western Maryland railroad. One of them had made a wrong turn and was backing.

To make the task of the drivers more difficult, a heavy rain and windstorm broke over them on the return trip. The clouds were so heavy that the men could see but a short distance before them, while on the turns the cars skidded, and many accidents were narrowly averted. The route of the contest was from Baltimore to Westminster, to Taneytown, to Emmittsburg, to Lanz, to Foxville, to Cavetown, to Hagerstown, and then to Middletown, to Frederick, to New Market, to Ridgeville, to Ellicott City, to Baltimore. Cars with perfect scores were:

No. of Car	Name of Car	H.P.	Driver
6	Ford	15	R. F. Kaehler
7	Oldsmobile	35	A. L. McCormick
11	Thomas	40	H. W. Gill
14	Winton	48	T. C. Goodwin
15	Packard	30	H. Hardesty
16	Thomas	60	E. F. Coley
17	Welch	50	Kelly
20	Pierce-Arrow	40	D. A. Clark
24	White	30	Lee Tremblay
25	Packard	30	William Keyser
27	Royal Tourist	45	P. R. Reese, Jr.
31	Packard	30	W. E. Baker
32	Franklin	28	W. Graham Hall
33	Buick	22	"Jack" White
34	Cadillac	20	L. M. Foster
35	Locomobile	40	Florida
9	Autocar	12	B. F. Gooden

**MINNEAPOLIS WILL HAVE 300-MILE RUN.**

MINNEAPOLIS, MINN., May 4.—On May 29 and 30, the Minneapolis Automobile Club will hold a 300-mile endurance run under the rules of the American Automobile Association. Col. Frank M. Joyce, president of the Minnesota organization, has received notification from more than twenty-five auto owners that they will enter the contest. The contest will be under the direction of judges from the outside. The start will be made from Minneapolis and the machines will proceed to Mankato, Minn., and return, and then from Minneapolis to St. Cloud and return, the complete trip totalling 300 miles.

**SOLDIERS TO GUARD BRIDGEPORT CLIMB.**

BRIDGEPORT, CONN., May 4.—Details of the preparations for the annual Decoration Day climb up Sport Hill were made known and approved at a meeting of the Automobile Club of Bridgeport, held last week. A. L. Riker, who will be the referee, reported that there would surely be a big field of entries, and that he had received from Walter C. White a promise to be a contender with his White steamer, which won the recent free-for-all cup at Fort George. The course will be guarded by the Fourteenth Company, Coast Artillery Corps, C. N. G., under Capt. George E. Hans. Ten deputies will serve as signalmen.

# HUNTING FOR THE ELUSIVE IGNITION CURRENT

By CHARLES B. HAYWARD.

**I**F a census of the automobile literature of the "How-and-What-to-Do" kind that has appeared since the beginning of the period when men who are neither mechanics nor electricians undertook to master the intricacies of the self-moving vehicle could be compiled, it is safe to say that it would show a great preponderance of advice on the subject of ignition troubles. Electricity has always formed one of the profoundest mysteries of everyday life to the man in the street, so that it is hardly to be wondered at that most of the "Helping Hand" contributions should deal with this subject. But as it is one of those things that cannot possibly be covered in less than a good sized volume, and as there are always new things to be learned about it and endless newcomers in the field of automobiling to learn them, the reason for making it a constantly recurring theme is plain.

## Percentage of Ignition Trouble Is High.

As is the case with everything else, it is the little things that count. Seldom, indeed, is the average autoist held up on the road by a broken axle, a smashed frame, or anything of so serious a nature. Inability to start the motor suffices to cover a multitude of road troubles in a few words, and of this host more than half are directly traceable to the defection of some part of the ignition system of the car—usually of a trivial nature. Until he reaches the point where he begins to realize that this most vexatious of misfortunes to the novice—failure to start—does not necessarily imply anything seriously wrong, the newly-fledged autoist is apt to regard an involuntary stop as meaning anything from a broken part up to an utterly ruined motor. But with even a little experience comes appreciation of the fact that minor worries are vastly in the majority, and that a broken battery connection is just as certain a means of bringing a car to a stop as a broken connecting rod, and very much safer. In the earlier days of their automobiling education many are apt to fear troubles of the latter sort and to look for them apprehensively when the car decides that it has gone far enough for the time being, regardless of the desires of its owner.

Such mishaps are not alone of very rare occurrence, but when they do happen to fall to the lot of an unsuspecting driver, there is never the faintest doubt of the serious nature of the accident. In other cases, it is chiefly the doubt of just what may constitute the cause of the trouble that is most vexatious. As the driver of Teutonic origin put it, meanwhile scratching his head in a most perplexed manner, "*I don't find my shpark anywheres, and I have looked him all over.*" The relative importance of the trouble is trivial compared with the difficulty that is encountered in locating it. Experience has shown it to be harder to confine a high-tension current within proper limits than it is to prevent leaks in a high-pressure compressed air system, with the further difference that the electric leak is not often so obliging as to visibly, or audibly, reveal its presence.

## Compiling a Breakdown Chart for Reference.

Many reference lists have been compiled for the aid of the trouble hunter, and a study of one of these statistical compilations of ailments will often prove of considerable assistance to a beginner. Their chief shortcoming is to be found in the fact that it is impossible to make any general set of recommendations apply to every case in particular, and, for that reason, the driver himself should see to it that he gets such things, and especially the order of their importance, well fixed in his mind, concerning his own car. I have often heard the question asked: "What goes wrong oftenest?" Applying this to the ignition system of a car, where of the usual battery and coil high-tension type, the enumeration might be started in the order of: first, timer; second, coil vibrators; third, wiring; fourth, spark plugs, and so on, this list presupposing that the battery is known to be in good con-

dition. In whatever order such a list be compiled, there can be little question but that the timer and vibrator will figure most prominently in it, and the degree of merit of each one of these devices will determine whether they are to rank first or second in the order of prominence as trouble makers.

To cite instances of ignition trouble that bother old hands for quite a few hours in their solution, would not be an extra difficult matter, but this is one that defied the combined efforts of several self-styled experts to unravel, and even then its solution was more or less of an accident. The chief difficulty usually lies in the fact that the symptoms are so misleading that one is quite certain they point to something other than what eventually is discovered to be at the root of the matter. This was the case in the instance under discussion which puzzled every one of a crew of five most sorely. First the motor came to a stop, and the manner in which it did so pointed to ignition trouble, for there is considerable to be learned from the action of the motor in this respect. Resort was had to the crank by one of the crew before any of the others could do any conclusive investigating, and the motor started on the first turn. It continued to run until every one of us had had a good opportunity to stretch and get comfortably settled back in the car, and then the motor gave up the ghost again.

## Symptoms So Often Prove Misleading.

This action of the motor gave rise to a difference in opinion as to the cause, and the diagnosis of ignition trouble arrived at as a result of the manner of the first stop, was considerably shaken. "Looked as if there were an obstruction in the gasoline feed line and the fuel is only coming through in small quantities, not fast enough to keep the motor running steadily," ventured one.

"Loose contact somewhere," tried another, each one trying his hand at a slightly different diagnosis.

But it is one thing where the motor resists all attempts to start it by cranking, and quite another where it will yield to this treatment. Turning the motor over on the crank was rewarded with a fresh start practically every time, but the period for which the motor continued to run varied from a few minutes to half an hour. There was no telling when it would give up the ghost, and as the party was desirous of getting somewhere, the annoyance of having to go trouble-hunting every few miles, and sometimes every few minutes, was exasperating. It was only by finally assigning each man a duty, thus instituting a systematic search, that the trouble was finally remedied.

While one man cranked to start the motor, and stood there to repeat the performance should it stop, another watched the timer minus its cover, a third kept tab on the carbureter, and still a fourth watched the vibrators of the coils. After two or three short runs that revealed nothing, the motor got under way and began to run so steadily that the trouble seemed to have disappeared of its own accord.

Fortunately, the watcher at the timer stuck to his post and noticed that it came to a stop shortly before the motor did. Cleaning out the case by flushing it with gasoline revealed the fact that the contact, which was ordinarily held to the vertical shaft by means of a set screw, had become loose. The holding screw had backed out just enough to permit the shaft to pick up the contact at times and hold on to it for a little while, then letting go. As the motor was turned over slowly by hand the contact seldom failed to be picked up, which accounted for the easy starting of the motor, while speeding the latter up was most often responsible for dropping it again.

Why it continued to hold at times and utterly refused to stick at others is one of those mysteries that only the erratic action of a machine out of adjustment can account for. About three

turns of the screwdriver sufficed to remedy what had taken hours to find. Instances of this kind could be multiplied indefinitely, and probably there are few autoists who have not puzzled over an apparently mysterious source of trouble for a long while, only to discover ultimately that it was so simple as to be childish.

#### Ignition and Carbureter Faults Sometimes Similar.

It was only natural that in the foregoing case the trouble should have been confused with a stoppage of the fuel system, as the symptoms were very much similar to those that are apt to occur when the fuel line becomes partly stopped up and does not permit enough gasoline to pass to keep the motor running at its usual speed. As soon as it has been stopped a few minutes, sufficient filters past the obstruction to render a new start possible, and as soon as this fuel is exhausted, the motor stops again to await a new supply. The same thing might be said of the battery, where dry cells are used, as it is well known that

they will recuperate sufficiently to run a motor within a very short time, even though they may have appeared to be absolutely dead but a few minutes previous.

Plugging of the carbureter jet by means of some obstruction that did not stick tightly in the nozzle opening, but which at times was drawn up into it, and at others fell back into the tube, would have been productive of similar symptoms, and was looked for in the case in question, but without result. So also were hidden causes of some intermittent short-circuit, similarly investigated, as the vibration of the motor's running will often permit the trouble being caused by a bad place in the wiring to go unnoticed, by keeping it away from the part with which it is making contact at times, and at others forcing it into that relation.

Road shocks are also guilty of doing the same thing, though this form of trouble is rare on the modern car, owing to the care taken not to use a superfluous inch of high-tension cable, and to protect every part of it over the motor.

## AMERICA SEEMS TO BE BUYING MORE FRENCH AUTOMOBILES

PARIS, May 1.—America continues to increase her imports of French automobiles, and Russia, Spain, Turkey, and Algeria buy more French cars than formerly, but this is not sufficient to prevent a serious drop in exports, as shown by official figures for January, February and March, just made public by the Customs and Finance Department.

The total French shrinkage is \$1,166,000 for the period under review, and of \$800,000 for the corresponding period of 1906. The figures given are for automobiles only, motorcycles and their parts and bicycles and parts being classed separately. A diminution amounting to almost \$600,000 a month is of such a serious nature as to cause some alarm among French automobile constructors. It is generally recognized that England is not likely to very greatly increase its imports, the tendency indeed being to establish branches of French factories in that country, and although American business has increased of late those acquainted with international affairs know that only the limited high-class business can be held by France.

Some authorities are rather pessimistic over the figures and predict a loss of \$6,000,000 on the year compared with the trade of 1907. Such is not likely to be the case, however, and wrong conclusions will be arrived at by taking January, February, and March as an indication of the trade of the entire year. The closing months of 1907 were exceptionally bad and to judge from present indications there will be an increase in business this year which will bring the total figures within reasonable distance of those of last year. Certainly 1908 will not equal 1907, but there does not appear to be any real reason why it should not be as successful as 1906.

Relief from the gradual shrinkage of French exports is generally considered to lie in the encouragement of trade with countries that have up to the present paid little attention to the automobile. France is making strong efforts, for instance, to

capture the Russian market, is striving to extend business in Algeria and Spain, and has an eye on the South American republics. Very much, too, might be done in the development of the home trade, France having a smaller number of automobiles in use than either England or America.

In the following table, compiled from the official returns, the volume of French exports of automobiles for the months of January, February, and March, 1907 and 1908, are shown in comparative form. In addition, the two last columns show either the increase or decrease on the first quarter of 1908 compared with the corresponding period of 1907:

	1907	1908	Increase	Decrease
Great Britain .....	\$3,375,400	\$2,610,800	.....	\$764,600
United States .....	528,600	749,000	\$220,400	.....
Germany .....	675,800	463,400	.....	212,400
Belgium .....	665,400	252,400	.....	413,000
Argentine Republic. . .	340,200	248,800	.....	91,400
Algeria .....	197,800	214,200	16,400	.....
Spain .....	109,200	155,400	46,200	.....
Brazil .....	194,800	133,200	.....	61,600
Russia .....	43,600	126,000	82,400	.....
Italy .....	269,000	108,800	.....	160,200
Switzerland .....	185,600	60,600	.....	125,000
Turkey .....	8,600	41,400	32,800	.....
Austria .....	35,600	13,400	.....	22,200
Other countries .....	1,007,800	784,600	.....	223,200
Total .....	\$7,637,400	\$5,962,000		

French imports of automobiles, motorcycles and bicycles show a slight increase for the first quarter of 1908, though the total is so slight that it is hardly worth considering. In January, February and March, 1906, France received foreign automobiles to the value of \$340,000; for the corresponding three months of 1907 the amount had dropped to \$326,200, and for the first quarter of the current year it had shrunk to \$273,000. Foreign motorcycles and parts were imported to the value of \$800 during the three months, compared with \$1,200 for the corresponding period twelve months earlier.

#### INDIANA IS BUYING AUTOS PLENTEOUSLY.

INDIANAPOLIS, IND., May 4.—There were 309 automobiles registered with the Secretary of State during April, the largest number in any one month since last July. This brings the total number of automobiles and motorcycles in the State to 5,734, of which about 200 are motorcycles.

A glance at the registrations indicates that by far the greater part of the business this year has been in low and medium-priced runabouts, with a fair representation of high-wheeled motor buggies. Quite a number of more expensive touring cars have been sold, however, and indications are that the 1908 season will be a record breaking one in Indiana.

#### WHERE FARMERS OWN THE AUTOS.

CRAWFORDSVILLE, IND.—This city will have its second annual automobile day on May 19, and several hundred visiting automobile owners from neighboring cities are expected to attend. A committee of business men has been successful in obtaining substantial cash contributions, which will be used as prizes for a number of events. There will be an automobile parade, followed by exhibitions of driving and novelty races, for which a fine list of attractive prizes are offered.

Crawfordsville is in the center of a rich farming district, the majority of automobiles owned in the county belong to the agricultural portion of the population.

## LETTERS INTERESTING AND INSTRUCTIVE

### HOW CAN CYLINDERS BE GROUND BY HAND?

Editor THE AUTOMOBILE:

[1,342.]—I wish to inquire through your most valuable paper if you or any of our readers know of any way I can grind a pair of imperfect cylinders and get good compression. I bought a new air-cooled, double-opposed engine, 4x4-inch, and the cylinders did not have a very good compression from the start. I looked the piston and rings over and found they were in good shape and a good fit, but the cylinders are off just enough to leak very badly.

Now, the question is, can I, while running the engine on gasoline, use either rotten stone or tripoli by placing it in the pipes (which are large) leading from the oil cups to the cylinders? In this way the grinding material will be fed to the piston with the oil, and in this manner gradually grind the cylinders; but will it grind only on the top and make matters worse, or will it grind the tight places?

I have a valve grinding paste, made by Brown & Co., of Syracuse, N. Y., which is quite mild and is a fine polisher. I think it contains no emery. Would you think it better to use it? If the above method is not a good one, could you or some of our readers tell me of a simple plan to overcome this difficulty?

Would it be better to remove the cylinders and pistons and grind them by hand with emery? This would be quicker, and one could see how things were coming. And then the emery could be washed off, so as not to get into the engine proper. As the engine is now it heats badly. One of the pistons was fitted just a little too tight, so when it gets hot it expands to the extent of causing friction, and this makes it heat very quickly. Do you think that this will wear to a fit and not get so tight, or had I ought to have it dressed down a little smaller?

I will be very much obliged if some one can help me out in the above matter, so I will not be compelled to send the engine back to the factory to be rebored.

V. R. LANE.

West Liberty, Ia.

It looks as if your troubles were due to having tried to save money on the first cost of a motor by investing in a cheap one. However, if the only fault to be found is that one of the pistons is a little tight, no grinding should be required. Motors selling at a very low price are naturally not given that attention in the way of finishing and testing that those selling for a much higher figure are. What your motor needs would seem to be running-in. Couple it to some other source of power and flood it with oil. Then run it steadily at a comparatively slow speed to prevent heating, for two or three days, when it should be sufficiently run-in to do away with the difficulty. We doubt if attempting to grind the piston into the cylinder by means of an abrasive would be all that was desired, but if any of our readers have ever made use of such an expedient, or have any suggestions to offer along this line we should be pleased to hear from them.

### WHAT IS THE CAUSE OF THIS OVERHEATING?

Editor THE AUTOMOBILE:

[1,343.]—Will you please tell me the probable cause of my engine overheating? My pump gives a good circulation, but the water in tank gets to boiling point after traveling two or three miles.

Jamaica, N. Y.

JOS. SYLVESTER.

Poor adjustment of the carbureter, which gives an over-rich mixture, is a very common cause of overheating, due to the fact that the charge continues to burn much longer than where it is of the proper proportions. It also develops a great deal more heat in burning, and a much greater proportion of this heat is necessarily absorbed by the cylinder walls owing to the greater length of time it takes to burn. Another cause of heating may be the fact that the fan belt is slipping, as some cars are so constituted that their motors will not run cool unless the fan, and, in fact, every other part of the cooling system, is working up to full efficiency.

Partial obstruction of the circulating pipes, or of the radiator, by deposits from the water employed for cooling, may also be cited as among the causes of overheating. The same thing applies to the jackets, which may be partly stopped up.

### FROM AN ADMIRER OF LETTERS INTERESTING.

Editor THE AUTOMOBILE:

[1,344.]—Your department of "Letters Interesting and Instructive" is, to my mind, one of the most valuable features of your publication, and I would like to see ten pages of these letters instead of the three or four which usually appear. Do you limit the space of this department, or are correspondents few? Here are some questions on which I would be glad to hear from you and from the readers of this department.

I have a 1907 Pope-Hartford. After running it ten months, I recently dismantled the engine to tighten a slightly loose connecting rod, in doing which it became necessary to disconnect the magneto, the couplings of which were carefully marked before removal, as were also the terminals of all wires. There is no question that everything went back exactly as it was taken off. The timer was not disturbed. However, after connecting up, the engine refused to start, and was found to be firing with the valves open. Previous to dismantling it was firing from front to rear in the order 1, 3, 2, 4. After some useless experimenting, I took off all connections, and, regardless of former arrangement, commenced at the rear or No. 4 cylinder and wired up so that the engine now fires in the order 4, 2, 3, 1. The engine runs perfectly, but as the wiring terminals are all marked in accordance with the old arrangement, I know there will be trouble the first time the car goes into the shop. I would like to change back to the old order but do not know how. An alleged expert who looked at the wiring tells me that any other arrangement is impossible, and that the car could never have run when wired up as I know it to have been. It did run for ten months, however. What is the matter?

On account of rough and "wavy" roads, I have been thinking of equipping the car with shock absorbers, but am told by various chauffeurs that they are "very hard on the engine." None of them offer any explanation as to why such should be the case, nor as to just what they do to the engine. Is this a superstition or has it some foundation?

After carefully reading the discussions which have appeared recently regarding the merits of the four and six-cylinder engines, I am firmly convinced that while they are both all right, each is a little better than the other. But why does neither side say anything as to the cost of fuel consumed? Does, for instance, a six-cylinder engine consume more gasoline per horsepower-hour than a four-cylinder, and if so, why?

I want to add a motorcycle to my equipment, but notice only one make advertised in "The Automobile" and none in other similar periodicals. I suppose the other manufacturers are still in business, and would like to have catalogues and prices. Here is a chance for some one to make a sale.

City of Mexico, Mex.

H. J. BRYANT.

That there is no scarcity of material for this department will be evident from the number of correspondents who have written us post haste to point out an error made in a recent issue. This is also a certain indication of the widespread interest that is taken in these letters and the answers thereto. Hence lack of space is the sole reason for not publishing a greater number of letters weekly.

Regarding the trouble with your car, we find that you have the same habit of making assumptions that lies at the root of the trouble of most of our correspondents. You say "there is no question that everything went back exactly as it was taken off." If this could be proven to be the case, then there is something wrong, but doubtless you will find that it is an assumption of fact not supported by the reality. Your reference to the timer not having been disturbed, in connection with what you say about the magneto, is slightly ambiguous, particularly as you do not add whether you finally got the motor running right on the battery or the magneto. To remedy the difficulty take the magneto off again; take out the spark plug, or open the pet cock, and drop a piece of stiff wire through the hole of the first cylinder, so that the position of the piston may be learned. The valve covers should also be removed.

Turn the engine over by hand until the piston of the first cylinder is at the upper dead center, about to descend on a power stroke, which may be learned by watching the valves and the wire indicator mentioned. Take off the distributor



cover of the magneto and turn the shaft of the latter until the finger corresponding to terminal No. 1 is just making contact. Mesh the magneto pinion with its driving gear, and if they do not exactly engage one another a half tooth's movement forward or back to make them do so will be immaterial, as it will be compensated for by the advance lever. Try the motor with the magneto in this position, and if it does not give as good a result as can be expected disconnect again and move the magneto pinion one tooth forward or backward, according to whether advance or retardation is required, and try again. As the magneto is synchronized to the motor, getting it in step with the first cylinder, makes it so with the rest of the motor. The mistake you made in putting it on as described was in starting with the rear cylinder instead of the front.

We have never heard of this latest theory of the chauffeurs regarding the damage done to the engine by the shock absorbers, but were laboring under a very strong impression that quite the reverse was the case, as the use of a good shock absorber not only adds to the comfort of the passengers, but acts as a means of protection to both the motor and the entire transmission. It has this effect by checking the reflex action of the springs, which would otherwise bounce the body into the air after each obstruction taken at any speed, thus preventing the continued alignment of the transmission shafts and the crankshaft of the motor. It is evident that more or less extra strain is imposed upon them every time the various parts of the transmission are thrown out of line. The comfort of the drivers and mechanics in a great road race is not usually a matter that entrants are particular about, but few, if any, racing cars run without shock absorbers, simply for the purpose of saving the engine and transmission as much as possible.

Six-cylinder advocates maintain a discreet silence on the subject of fuel consumption, as it is a matter of common knowledge that "miles per gallon" decrease at a startlingly rapid pace with each addition to the size and number of the cylinders. Naturally the six-cylinder motor of an equivalent cubic capacity, or piston displacement, with a four consumes more fuel than the latter, owing to the extra parts to be moved, greater heat losses through cylinder walls, and other factors affecting its efficiency, and figuring this way naturally leads one back to the single-cylinder. The advantages of the six are usually conceded to compensate for the extra fuel required.

There are other motorcycle manufacturers in existence and there are also a number of agents for imported machines in this city, to whom we have given your name.

#### REGARDING THE ERRONEOUS DIAGRAM.

Editor THE AUTOMOBILE:

[1,344.]—In your answer to letter No. 1,319, regarding wiring cells for a single-cylinder motor, wish to say that I do not believe this diagram is quite correct, if I understand it right. As far as I can see, one wire is taken from the last carbon in each set to point No. 3 on the switch. It appears in the diagram that it would not make any difference whether you had a switch lever standing on points Nos. 1, 2, or 3. Supposing you have the switch lever standing on point No. 1, with the wiring as indicated in diagram, does it not appear to you that the current will pass through the wire from the carbon in set No. 2 through point No. 3 and further from point No. 3 to the carbon of set No. 1 and from there to the wire of point No. 1? Consequently, this would give a series of multiple connection on either one of the three switch points. If I am not correct I would be pleased to have you explain diagram further, as I think it would interest many of your readers.

ARTHUR BEIJER.

Phillips, Wis.

You are quite right about the wiring diagram not being accurate when taken in connection with the explanation given, as it shows the cells permanently connected in series-multiple and, as is called attention to here by quite a number of subscribers other than yourself, the effect of this

would be that turning the switch to any one of the points would give the same result. It was inadvertently omitted to state that the expedient of making the connection to point 3 of the switch was not to be undertaken until the cells were no longer serviceable independently, but even at that there are modifications of the method of wiring which would render doing this much simpler and more convenient. These are called attention to by subscribers in this issue, as will be seen by the letters following. It is gratifying to note that such a number of the readers of Letters Interesting and Instructive were so quick to detect this error and call attention to it. The manner in which the error is pointed out and the necessary corrections called attention to in the foregoing, as well as the following letters, show that the average autoist's knowledge is no longer the limited commodity that it once was, and that it must be respected accordingly.

#### EXPERIENCE WITH CORK AND OIL "DOPE."

Editor THE AUTOMOBILE:

[1,345.]—Referring to your answer to inquiry No. 1,319, in the April 23 issue, beg to say that wiring a diagram as published will not permit using each set of batteries alternately, for the simple reason that the two sets are permanently connected in multiple by the wires running from the carbon terminals to point No. 3 on switch. Thus the two sets would discharge in parallel, no matter whether switch lever was on point Nos. 1, 2, or 3. The timer was not shown in the diagram, but, of course, this essential could be located at either end of the circuit, so that the current would reach the ground return through the timer shaft. In regard to the switch connections, I would suggest that Mr. Carpenter wire his two sets of cells in the usual way; that is, as shown in the diagram, with the exception of the wire between the carbon poles and point No. 3. Then he could use either set separately, and when the cells become weak, they could be used in multiple by slipping a thin strip of brass under the switch lever so as to bridge points Nos. 1 and 2, and at the same time connect them to the lever.

Referring to inquiry No. 1,321, would say that I have had some experience with "dopes" for silencing gears, which may be of some benefit to Mr. Hall. Last summer I experimented on a badly worn and very noisy planetary transmission in an Olds runabout. First I tried mixing boxwood, or "jewelers'" sawdust, with oil, but the sawdust being heavier than the oil, was thrown to the outside of the case, owing to centrifugal force, and was found tightly packed around the rim when the transmission was opened. Then I hit upon the idea of using cork filings, and this material gave excellent results. The mixture was prepared by filing old corks with a very coarse file or rasp. The filings were then screened through a piece of ordinary window screening, the coarse pieces being rejected. The fine filings were mixed with rather heavy cylinder oil in the proportion of about one part by volume of cork to two or three parts of oil. When this mixture was used in the transmission, the gears made hardly any noise at all. One filing would last for several hundred miles, or until the mixture had leaked out around the shaft. As the cork would float in the oil, there was no danger of its packing, and the fine particle adhering to the gear teeth acted like "cork inserts," filling up the spaces between the worn teeth. I would certainly recommend the "cork" treatment to any one troubled with noisy gears.

ALLAN W. PATTEE.

Monmouth, Ill.

#### ANOTHER SUBSCRIBER TAKES THE ISSUE.

Editor THE AUTOMOBILE:

[1,346.]—As a subscriber to your paper, I have always been an appreciative reader of your "Letters Interesting and Instructive." However, I beg at this time to take issue with you in regard to your reply and wiring diagram in answer to No. 1,319, in the issue of April 23. While I do not wish to infer that the editor does not know how to make a series, or series-multiple connection, still his statements are at least quite misleading, and his diagram incorrect.

The diagram, taken by itself, shows two sets of four batteries connected in series, with the carbon terminal of the upper set connected to terminal No. 1, the lower set to terminal No. 2 of a 3-point switch. Also the carbon terminal of each set to terminal No. 3 of the switch. This last mentioned connection makes a series-multiple connection of the batteries when the switch is on either point No. 1 or No. 2. The diagram shows all permanent connections (all lines being full, not broken), and the text does not even infer that the connections to point No. 3 are of a temporary nature, to be made only when the series-multiple connection is desired.

Why provide a three-point switch? Why not use a two-point

switch, and connect the carbon terminals with an ordinary battery connector when series-multiple connection is desired, or provide no switch at all if the coil box has a two-point switch, which it probably has in nearly all cases.

While I appreciate Mr. Carpenter asked for a battery wiring diagram for a single-cylinder motor, your reply was for the benefit of your subscribers, which a majority no doubt are more definitely interested in multiple-cylinder engines. The principal part of the diagram, i. e., up to and including the switch, applies equally as well to a two or four-cylinder as to a single-cylinder engine, still you do not intimate this. If the readers know little or nothing about connecting batteries, they would not know this, and if they understand connecting batteries your article is of no value to them. Please do not think me too critical, but I first noticed this article in "Motor Age" and considered making a reply. Later read it again in "The Automobile," and was again seized with the desire to reply to it. On comparing the two articles I find they have the same author.

W. A. YOUNG.

Muskegon, Mich.

### HOW THE WIRING SHOULD HAVE BEEN DONE.

Editor THE AUTOMOBILE:

[1,347.]—A glance will show that your diagram for letter 1,319 is incorrect. Placing the switch lever on either 1, 2, or 3, will have the same effect, for the two sets are always connected in parallel, through point 3, and no movement of the switch lever can alter the connection. If, however, point 3 be omitted and a small extra switch be placed in the circuit connecting the two sets in parallel, then placing the master switch on either 1 or 2, with the extra switch closed, will give the use of the two sets in parallel, while if the extra switch be opened, the two sets may be used independently.

The same end is sometimes attained by omitting point 3 and its circuit, and making the switch lever wide enough to span both 1 and 2 at the same time. Then placing the switch at its central position would connect the two sets in parallel.

Allgheny, Pa.

MURRAY FAHNESTOCK.

### WHY NOT USE A RATIONAL SIZED MOTOR?

Editor THE AUTOMOBILE:

[1,348.]—The general tendency of motor car design abroad is toward the smaller sized motor. While the roads of Europe are, as a general thing, much better than those in America, yet this in itself does not render possible the smaller sizes of motors, which are being used in fairly large cars over there. The fact that the foreign driver is much more willing to make frequent use of his gear shift has more to do with the problem than has good roads.

In America the demand seems to be that the relation of motor power to weight of car must be such that the machine will go romping up the steepest kind of a hill upon the high gear. As a result of this demand, American manufacturers are being forced to equip their cars with motors which cannot be operated economically upon any low or moderate road speed.

Not only is the first cost of the car increased by the necessity of building its component parts of such strength as to transmit the extreme power of the large motor, but any engineer will tell you that a large power plant cannot be operated economically when 90 per cent. of its work is done at about half of its possible capacity. In other words, it is wasteful of both gasoline and lubricating oil to operate a large motor under conditions where only about half of its possible power may be utilized except at rare intervals. Certainly, sooner or later, the American public will begin to realize, as have the foreign drivers, that it is much better to make use of the transmission which has been placed by the maker in the car for a purpose, than to demand a car with such motor equipment that it may be operated at all times without recourse to the intermediate gearing.

In an effort to meet the demand for a car which will climb any hill upon the high gear, the manufacturer is confronted by two possibilities, both equally bad. Upon the one hand he may equip the car with an abnormally large motor, and upon the other hand he may so reduce the gearing between the engine and the rear axle that the car may perform satisfactory hill climbing feats upon the high gear. In the first case, there will occur the greater first cost of the large motor and of the heavy driving gear rendered necessary by this large motor. To this may be added also the cost of maintenance, and the lack of efficiency under the ordinary road conditions.

In the second case, where the motor of a smaller, or perhaps more proper size, is geared down to such an extent that any kind of hill may be climbed upon the direct gear, it is very apparent that for ordinary driving upon the level road, and especially if this driving be at all fast, the motor will be required to have an extremely high rotational speed in relation to the number of revolutions per minute of the driving road wheels. This extremely high speed tends, of course, to shorten the life of the motor, to render adjustment of bearings and other parts more frequent, to increase

lubrication trouble, and to cause an unpleasant vibration to be felt by occupants of the car whether it is running or standing.

Would it not be much better to educate the American public along the line of European practice, building the motor car with an engine of moderate size and with a gearing between engine and drive wheels, which would insure to this motor a satisfactory rotative speed at the average driving speed of the ordinary operator? Such a construction would, of course, necessitate the use of the gear shift lever for hill work, but with the modern designs of gear shift this certainly cannot be looked upon as a serious hardship. Certain it is that it would be far more sensible and far preferable from the manufacturers' standpoint, were this done. This, of course, to say nothing of the money saved to the operator and owner, both in first cost and in operating expenses.

Moral: Don't be afraid to make use of your gear shift lever. Have your car geared at a proper road speed; such that upon the level your motor is not racing itself to death and upon the hill do not be afraid to shift into your second or your first speed, as may be required. You will find that your machine will stand up better, and that it will be in your service every day, instead of in the repair shop.

HOWARD E. COFFIN,

First Vice-Pres., E. R. Thomas Detroit Company.

Detroit, Mich.

### FORD TROUBLES AND THE NEEDLE VALVE.

Editor THE AUTOMOBILE:

[1,349.]—Noting letter 1,324 and others in your "Letters Interesting and Instructive," recommending separation of gasoline tube and exhaust pipe as a remedy for Model N Ford troubles, will say that I think the idea good, as I have noted, though could never understand why, my Fords gave better power when started up cold than when heated, which is, of course, contrary to theory and also to practice with other cars. But, from my experience and that of others of which I know I conclude the troubles inquired about, or the necessity of "tickling" or changing the needle valve every few miles, more or less, will not be remedied by the prescribed treatment.

I think we will necessarily have to go back to the long-drawn-out discussion of "needle valve vs. no needle valve," which, it seems to me, left us quite in the dark after all. I believe that the needle valve is like money, which is said to be the root of all evil, and surely is the cause of some of it; but nevertheless quite desirable, convenient and even necessary. It is the misuse of money that brought this condemnation upon it, which is equally true of the needle valve.

I had a Ford runabout with 1906 carbureter which seemed almost ideal. It developed less power when hot, but as we always had lots to spare when either hot or cold it caused us no inconvenience. I got one with same make but 1907 model carbureter, at which time bothers began and stayed until I changed the gasoline feed nozzle from a 9-64 inch to a 1-16 inch hole, since which everything has been entirely satisfactory. I had all of Mr. Fay's needle valve troubles, which are really not needle troubles at all, but nozzle troubles.

The distance between needle and nozzle through which the gasoline flows when needle is adjusted is now about 1-200 part of an inch, and before the change was made was less than 1-400 inch. You see this space was so thin that it coated slightly and choked the motor. I think perhaps a 3-64 inch hole might be better than a 1-16, as it would give greater latitude of adjustment.

Whether these carbureters were designed for larger cars, or whether these large nozzles were put in by error I do not know, but I am sure they have gotten in some bad work on the Ford, and from Mr. Fay's and others' experiences I infer that it has not been worse on Fords than on other cars. By having small nozzle, no delicate needle adjustment is required. After having it once right needle may be turned down gently until seated, using care to not screw it in hard enough to make nozzle larger, and noting how far it was turned it may be brought back or taken out with little liability of disarrangement. While I think the needle valve is all right, we should not use too much of it; that is, the nearer the top of the nozzle the points works, the better it is.

Prattsburg, N. Y.

FRED. D. CLARK.

### CARBURETER OR VIBRATORS MAY BE CAUSE.

Editor THE AUTOMOBILE:

[1,350.]—In answer to your inquiry regarding C. J. Radway's troubles with his Maxwell, would state that sticking vibrators or the flooding of the carbureter during the time the car is not in use would cause it. The results of this would make a black smoke come from the muffler, caused by the excess gas which was not exploded. Sticking vibrators would cause results very similar, as the vibrator sticking would stop the explosion in the cylinder and the unexploded gas comes out of the exhaust pipe as a black smoke. When the engine gets going the motor aids a sticking vibrator, and you would then notice better results at once. I hope this will aid Mr. Radway at least a little in his troubles.

Dallas, Texas.

WELDON A. FOSDICK.



Along Skippers Road, New Zealand, Showing the Rough Nature of the Country Through Which Road Has Been Cut to the Gold Reefs.

**FARTHEST SOUTH IN THE AUTO.**

AUCKLAND, N. Z., April 8.—Take an ordinary map of the world, look up New Zealand in the South Pacific Ocean, and its size will appear dwarfed by the immensity of the surrounding waters. Yet this progressive land is very nearly the size of Italy, and not unlike it in form, with the north and south positions reversed. Two large islands, separated by Cook Strait, 16 miles in width at its narrowest point, and a number of smaller islands, comprise the colony. North Island has an area of 44,468 square miles, and South Island is 54,525 square miles in extent.

It is along the southeast region of South Island, on the eastern slope of the Southern Alps that the beautiful scenery predominates which is shown in the photographs. With the march of civilization, the automobile now safely rolls along the picturesque routes once peopled by the wild and savage Maoris.

Mt. Cook, which stretches its snow-capped peak 12,349 feet above the sea, crowns the range known as the Southern Alps. Great



Lake Wakatipu and Road Embankment.



Lighthouse Rock, on Skippers Road.

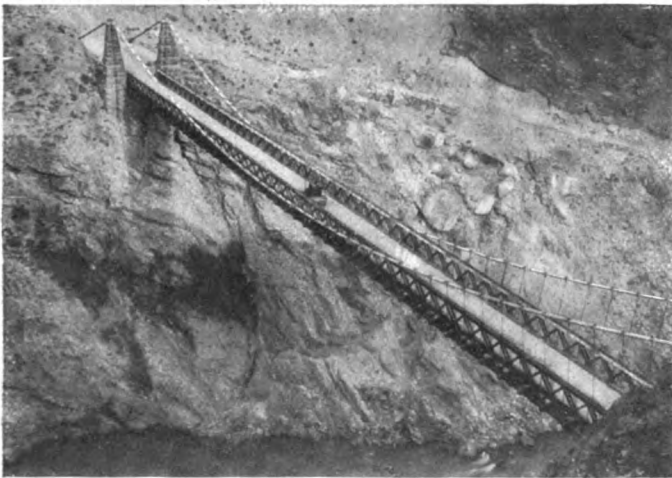

Suspension Bridge Connecting Cromwell with Bannockburn.

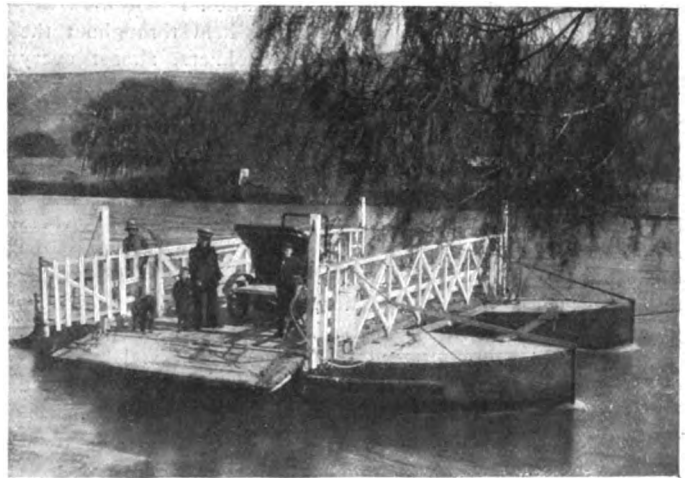

Crossing Molyneaux River, Lowburn Punt, near Cromwell.



Fording Catilus River, Southland.

glaciers extend their icy arms to within a few hundred feet of the sea on the western coast, but the eastern slope is more gradual, and it is here that generous nature has softened the rugged grandeur with a charm to be found nowhere else south of the equator, and produced a garden spot famous for its wealth of agricultural products and wool growing.

A number of beautiful mountain lakes heighten the effect of the scenery, and the largest of these, Lake Wakatipu, rivals the famous Lake Lucerne of Switzerland in picturesqueness. Its surface is 1,060 feet above the sea, yet its greatest depth extends to 500 feet below the ocean level. The roads are as a general rule of the pioneer type, but an automobile has little difficulty in traversing them, and extensive improvements are being made in the more thickly populated districts. The hardest parts of the South Island to travel are the heavy sand drifts between Cromwell and Lowburn Punt.

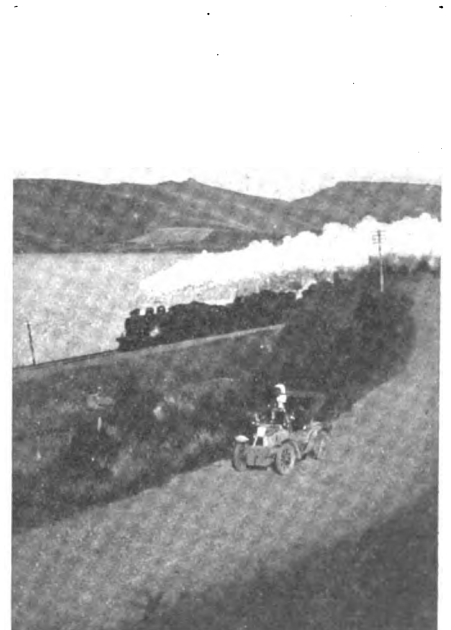

A Flutter with the Express.



## THE AUTO IN A NEW FIELD, DOWN IN THE SOUTHWEST

By A. C. BUILDER.

DOWN here in the Southwest, where the country has not attained the age and development that begets a public spirit of road building, the genius of a most patient and careful chauffeur would be taxed to safely steer his machine over the ditchy slopes, long sand beds and through the sloughs of the timbered bottoms. Of course, this condition exists only in the rougher sections, while out on the prairie and the level country—places of good roads by nature—it is easy work to handle the car, and their "honks!" are often heard, and are becoming more numerous; ranchmen, some of the more well-to-do planters, physicians and others have them, so they are not the novelty they are in the sections first mentioned. But as time and progress puts the roads in condition, and the citizenship is enriched by a long-established habitation, the financial side of the proposition will not be the luminous obstacle that it now is; the auto—itsself a money-maker and road promoter—will come to its own.

This bit of writing has to do with the last Summer's experience of two young men living in a portion of the State (Texas) of not sparse population, where there are farms, mills, shops, railways, and all the modern conveniences of the smaller cities of any other section of the country, but where there was not one automobile in a stretch of several counties.

During the Summer months there are held throughout the South reunions of the ex-Confederate soldiers, almost every county having an organized "Camp" and Confederate park, or camping ground, located at some central point. These reunions have become, locally, the event of the year, and are attended during their continuance (which is usually three days, with night programs) by almost the entire citizenship. The program, outside of public speaking and concert features, is enlivened by races and games, and the gathering partakes much of the nature of the county fair. At these reunions it has been the custom for the committee on ground privileges to grant permits to hackdrivers (to as many as desired to pay the fee) to transfer the visitors, as well as home folks, to and fro between park and "square," or depot, as the case may be. The park is generally located within a mile of town, and the fare charged by hackmen is from 10 to 25 cents. There are usually from five to ten thousand visitors in attendance at these reunions, size of crowd, of course, depending upon membership of the "Camp" and attractiveness of the program.

Two young men of limited means, who, upon a visit to the city, had longingly eyed a honking, whirring streak of red, conceived the idea of purchasing a car and making it pay for itself by carrying passengers in competition with the hackmen at the forthcoming reunion. It was with many misgivings that they entered upon the speculation, both being pioneers in the venture, and without any automobiling experience whatever. It was a question whether the people would patronize them or hold to the old methods; this was to be risked.

The next thing was the selection of a car; not an easy matter, nor a thing to be decided at once. The primary use to which it was to be put was to last a few days only, and they must have a machine that would be of some utility in this country of bad roads after the reunion was over. They had begun their contemplations a couple of months before the car was to be used, and had burdened their mail with catalogues and prices from every salesman whose address they were able to obtain. And they loaded up on automobile lore—fiction and fact—while making their decision as to the proper car for their purposes. They decided upon a 30-horsepower, four-cylinder, chain-driven, five-passenger touring car, with top. With a few hundred dollars down, this car was to be placed at their station, the total price being \$2,000.

And if Fulton was ever derided by the skeptical as to the steamboat, these young men were, by a certain element of their

community, when their intentions were made known, while others were more friendly to the idea, and were glad to see the experiment made.

The car came, and with it a chauffeur from the agency in the nearest city, and within a few hours the boys had mastered the essential rules in piloting an automobile. As the days of the reunion approached, they became more expert; they could miss a stump, round a corner, and dodge a pedestrian pretty well, and they had also gentled a goodly number of the horses.

They secured from the committee on ground privileges, for a fee of \$4, an exclusive circuit roadway from city to park grounds; this, in anticipation, they had selected and cleared of all possible hindrances. They placed their price at 25 cents, one-way trip, the distance being about one mile. The automobile was given the place of honor in the parade, conveying the captain of the camp, the sponsor, and her maids of honor. After this first trip, it was an incessant conveyor of passengers from early morn to almost midnight throughout the three days. On the city square it nosed about among the hacks and surreys with the dignity of a big ocean liner among a lot of sailing craft.

The owners worked in relief, acting as ticket agent and chauffeur. No time was lost in loading; the merrymakers flocked to it like blackbirds to a rye field, often more piling on than could be safely carried. The new auto was a better coin gatherer in proportion to capital invested than Barnum's circus. Of course, there were accidents and breakdowns, but the young men had wisely provided against this as much as possible by having on hand and ready those supplies most likely to be needed.

It is easily seen that this introduction of the automobile was a great advertisement in the community for that make of machines and the company selling them. Since then, three more have been brought to the place. The entire three days was a success to the young men—even unto the last their patronage did not wane. And this is not all; three reunions were held in as many neighboring counties after this one. They had only to drive over cross-country and buy a right-of-way privilege from the committee. The business at each was excellent.

Let any chauffeur compute the amount he would have by loading his car to its utmost capacity at 25 cents per passenger, seats full, wedged in between, sitting in laps, and swinging to side and on behind; make trips of one mile in length from early morn until almost midnight for eleven days (one reunion was of only two days' duration) and see if the total would not pay for a car, "and then some."

These young men have their car in pretty good order yet, and will have her in trim for the coming reunion season.

### AUTOS NUMEROUS IN WESTERN KANSAS.

TOPEKA, KAS., May 4.—The automobile is coming to be a very familiar object in Western Kansas towns. Many farmers are putting them into use also. Men who own farms and ranches use them to make daily or occasional trips to their properties. Many of the rural route mail carriers think they are "just the thing," and so two railroad men are using them out of Kinsley.

Kinsley has a garage, in charge of Lee Hardy, who has the agency for the Maxwell machine, and he has placed some fifteen of that make here at Kinsley and at Lewis, a town eight miles east of Kinsley. Four of the doctors in the two towns own and use runabouts. The real estate man almost invariably has one or two cars at his disposal, and feels that he cannot get along without a machine in his business.

The excellent roads in this part of Kansas are an inducement for using autos, for even after a heavy rain it is but a few hours until all is O. K. for an auto ride. Merchants, auctioneers and stock men are all investing in machines, to be used for profit or pleasure.

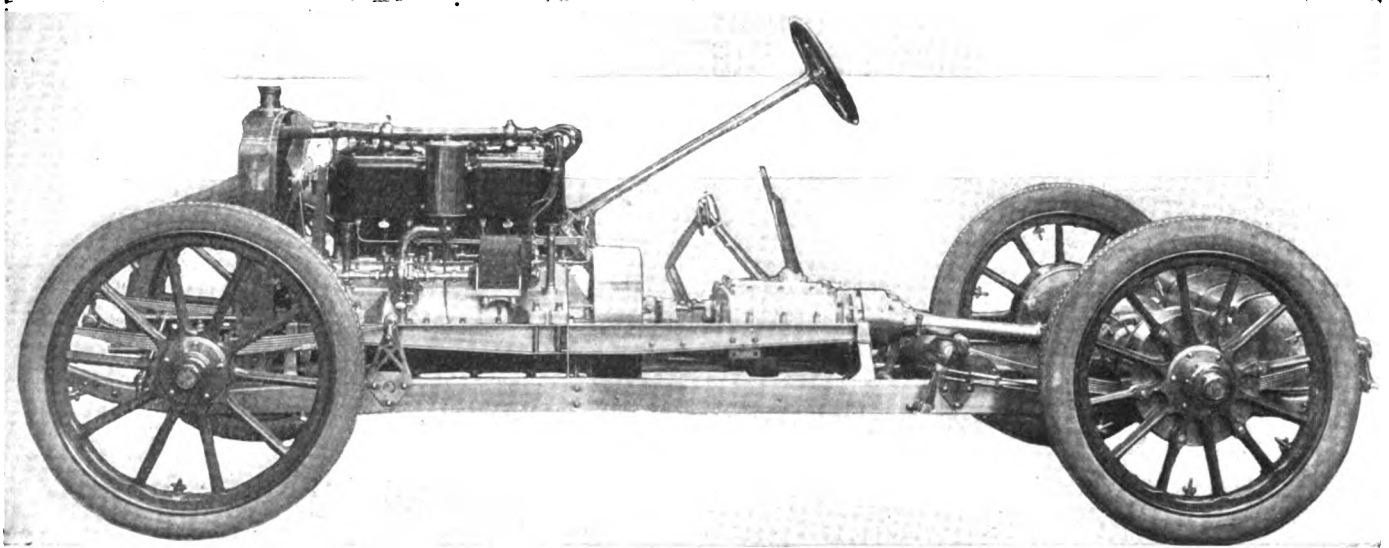

Racy Lines of the Underhung Chassis of the American Roadster.

**FOUR AMERICAN MODELS FOR 1908.**

Although the American Motor Car Company, Indianapolis, Ind., has shown that progressiveness so characteristic of American builders, by bringing out roadster and touring car models, neither of these has lost any of the features which made it conspicuous in the 1907 season; the roadster uses the under-swung frame, the touring cars the frame carried above the axle. Four 1908 American models are marketed. A 40-horsepower type, with not a few 1908 refinements, is built in roadster and five-passenger touring car styles, while the two models are mounted on 50-horsepower chassis, fitted with roadster and seven-passenger touring car bodies, the roadster style having, as in the case of the 40, the under-swung frame.

These 50-horsepower chassis stand for the representative '08 product of the factory, in that they are new models, having been made in but small quantities during the past season, in which season the 40-horsepower chassis were the standard constructions. A few differences exist between the 40 and 50, foremost in which is the use of a four-speed and reverse selective gear set in the 50 and the adherence to a three-speed progressive set in the 40. Besides the under-swung frame, the roadsters differ from the touring cars in that the latter employ a rear platform spring, whereas the semi-elliptic type are in regular use in the front and rear on the roadsters. The touring cars and roadsters in the 40 and 50 models vary slightly in wheelbase, the 40 roadster wheelbase measuring 106 inches, whereas the touring car is 116; and in the 50-horsepower chassis the roadster wheelbase is 110, but the touring car measures 124 inches, this additional length giving opportunity for the use of two additional tonneau seats. According to A. L. A. M. rating, the 40 chassis with its 5 by 5-inch cylinders works out exactly 40-horsepower, but the 50 chassis, with its 5 1-4

by 5 1-2-inch cylinders and long stroke, comes to 44.1 horsepower.

The American motor follows that conventional type employing cylinders cast in pairs with valves carried in expansion chambers on the right side and opened through direct lift from a camshaft carried within the crankcase. A neat disposition of the motor parts has been accomplished by carrying the Schebler carbureter centrally to the right and the timer on the top of a vertical shaft between the twin castings on this side. Aside from these general motor marks there are a few interesting details about it that remove it from the realm of pure conventionality. The top half of the crankcase serves as a pan or mud apron construction and in the touring models rests directly on the side members of the frame, thereby eliminating a subframe construction; whereas, in the roadsters a super-frame is required. The gears at the forward end of the crankshaft and camshaft are of the spiral type running in oil, and instead of keying them to the shafts they are coupled to flanges on the shafts. The crankshaft pinion is steel, whereas that on the camshaft is built up of fiber and gray iron. Use is made of separate cams keyed and pinned in position, the camshaft is carried on a bronze bearing between adjacent pairs of cams and the bearings are of slightly different diameter in order to permit of an endwise movement of the whole shaft when taking it out. A change over 1907 construction is carrying the timer on a vertical shaft

at the right between the cylinder castings instead of on a short vertical shaft beneath the dash. This driveshaft is encased in an aluminum housing, the top end of which is anchored, while at the lower end is a shoulder fitting into a pocket in the crankcase. The vertical timer shaft is arranged with a slip joint in it and at the lower end carries a worm which meshes with a worm wheel on the camshaft; and by the use of a lever with ball end which bears against a ball thrust washer, the lower end of the timer shaft and the worm can be moved upwards

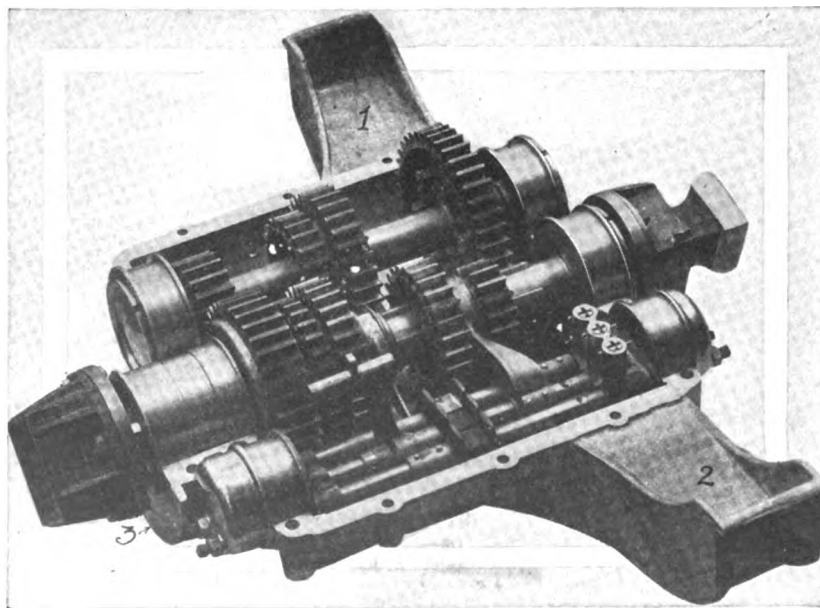

Change Gear Set of American Touring Model, Showing Three-point Support.

or downwards, thereby advancing or retarding the contacts of the timer while the exterior of the timer, to which the wires are attached, remains stationary.

Use is made of a double ignition system employing two sets of plugs located respectively in the caps over the intake and exhaust valves, the high-tension wires to which are neatly housed in a large diameter tube carried above the cylinder heads. In this tube are only six wires, those for the two plugs in the rear cylinder not entering it. Current for one set comes from a high-tension Simms-Bosch magneto with self-contained distributor and for the other set from a storage battery. Motor lubrication is effected through a five-feed lubricator, located under the floor boards in the touring car and housed within the hollow dash in the roadster. In the cooling of the motor, a few strictly American constructions are found; the water enters the cylinder jackets at a point on each side of the exhaust, the aim being to equalize the cylinder temperatures. The fan is supported on ball-bearings carried on a small shaft supported at the end of an arm clamped to a boss on the front cylinder casting, which arrangement allows of the removal of the fan without disturbing other parts. The blades are made integral with the aluminum hub.

It is when coming to the transmission part of the car that the several changes over '07 construction appear, namely, the employment of selective gear set, as well as that of double expanding brakes, acting within the same rear wheel drums, the expanding members being located side by side and made with the same diameter and width. The selective gear-set, that for the touring car illustrated herewith, has the main and countershaft carried side by side in the same horizontal plane and carries the shafts on annular ball bearings. The case, made in upper and lower halves, has a three-point support in the touring car model, these points being at opposite front corners and at the rear center, the last point being on a drop cross-piece of the frame. The cone clutch used in all models is held in engagement by a spring made from 1-4 by 1-inch flat stock, wound spirally, the thrust of which is taken by large ball-bearings encased in the hub of the clutch and packed with non-fluid oil. Between the clutch and gear-set is a square end coupling made in halves to facilitate adjustment of the spring. This coupling also makes it possible to remove the clutch without molesting the motor or transmission.

The rear axle construction of the American cars includes bevel gear drive to a floating type of axle, the car weight being carried on the axle housing and the axle driveshaft revolving the wheels by means of square inner ends engaging the differential and square outer ends engaging the jaw clutches. On each of the rear wheels is a double set of expanding brakes located side by side and operating within the same steel drum. The two brakes are exactly alike and work under similar conditions all the time excepting in that the expanding shoes are pivoted at diametrically opposite points, one at the front and the other at the rear stud, forming the support, each not only acting as a support for one of the brakes but a portion of it being formed into an expanding cam for applying the other brake to its respective drum.

The frames employed in the touring cars consist of the side members and three cross-pieces, the former having a 5-inch vertical depth, a 1 3-4 horizontal web and manufactured from 3-16-inch stock; there is a rise in the side members of 2 1-2 inches in front of the rear axle, which is done to increase the possible range of action of the platform spring. Supporting the rear cross member, the

center of which carries a triangular bracket, bearing upon the center of the transverse spring, are two long diagonal braces extending from the side members at a point ahead of the rear axle. In addition to the three cross members already mentioned, the crankcase further acts as a tie for the front of the frame and the gear-set serves a similar purpose midway of the side members. The roadster frame embodies side members narrowed at the dash as well as a pair of straight supplementary frame pieces raised higher than the main frame members, and on which supplementary pieces are carried the motor and gear-set. In this frame construction the forward springs are placed on top of the front axle with their rear ends carried in a fixture riveted to the upper side of the frame, and their front ends linked to the end of the frame. The semi-elliptic rear springs are revolvably mounted on the back axle with their forward ends connected to brackets on the upper side of the frame and their rear ends connected to a crossbar which passes completely across from sill to sill of the car. With this construction, the company claims that should the spring break at the forward end, as the bolt comes out, the frame simply drops about an inch, and no material damage is done; in fact, the further claim is made that, for demonstrating, the cars are often driven with the forward end of one of the front springs unsupported. In spite of the use of this drop frame construction, the car has a clearance of 10 1-4 inches, the upper side being protected by a practically flat shield plate. In the 40 roadster, 36-inch wheels carry 3 1-2 and 4-inch tires; the 40 tourist, with the same diameter wheels, uses 4-inch pneumatics front and rear; in the 50 roadster the sizes are as in the 40; but in the 50 tourist 4 and 5-inch sizes are in use in front and rear.

It will be apparent from the foregoing that, with the single exception of the under-swung frame of the roadster type, there is no marked departure from engineering practice current with the majority of designers in this country, though many of the minor details of the power plant and transmission of the different models have been worked out in a distinctive manner, showing the painstaking attention that has been devoted to the small things. In fact, this is evident on every part of the American cars. The design of the under-swung frame type of car, which is continued this year, was so well executed in the original that practically no changes were found necessary to bring it up to date, something that is very frequently necessary on the later editions of first models. This American roadster is an excellent illustration of the fact that a low hung car need not necessarily lack clearance, as it has more than many of the ordinary type.

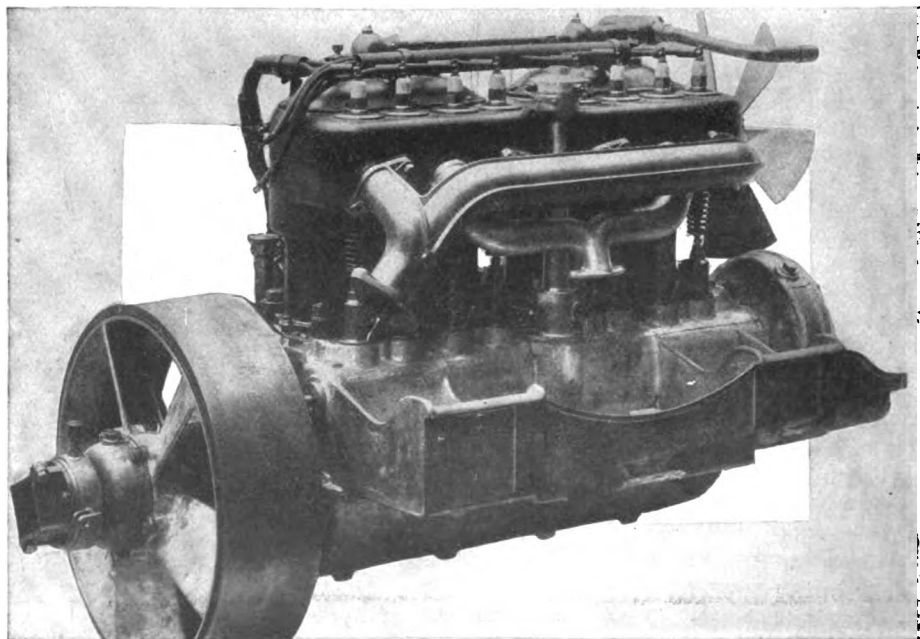

Operating Side of the 50-horsepower Motor of the American Touring Car.

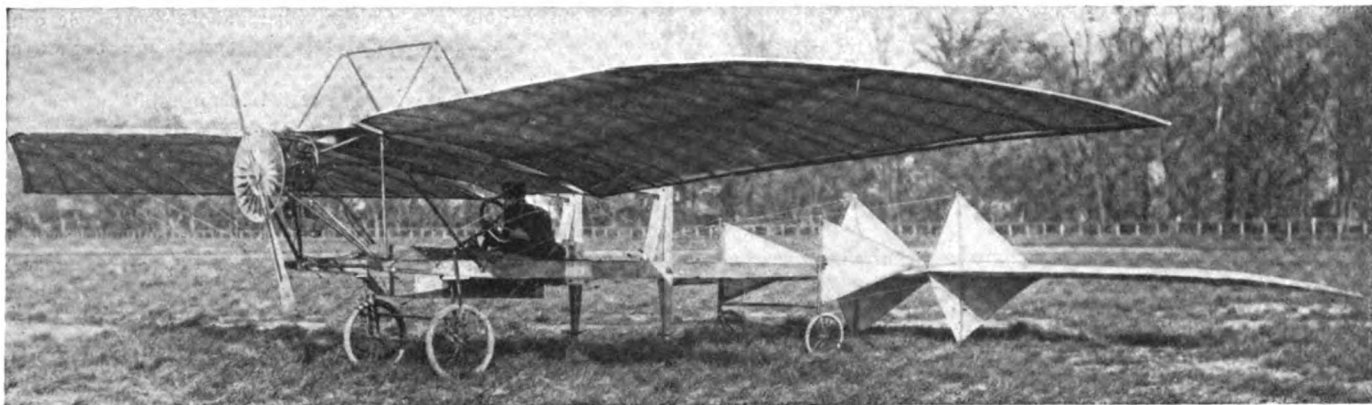

One of the Latest French Flyers—The Aeroplane Blanc at Marseilles Ready for a Trial.

### FRENCH AERONAUTS ARE BUSY.

PARIS, May 1.—Tremendous activity is being displayed at all the aeronautical shops in and around Paris—and their number is now by no means small. At the Voisin Frères shop, in addition to several aeroplanes very similar to the one used by Delagrangé in his recent record flight, an entirely new machine of the monoplane type is being pushed forward for Henry Farman. The aeroplane, which is known as the *Flying Fish*, will be fitted with the first of the eight-cylinder air-cooled engines that Renault has just produced. This week the entire frame work of the aeroplane was completed, and it was only waiting for its power plant and canvas covering.

The most original and at the same time one of the most promising of aeroplanes ever built is now receiving finishing touches at the Antoinette factory. Its chief interest lies in the fact that it is the first heavier-than-air machine to be constructed to carry two people, the mechanic and pilot occupying entirely separate positions in the new Antoinette.

M. Levavasseur, who has designed the aeroplane, is the builder of the extra light Antoinette engines used by the most successful aeronauts, and head of the Antoinette company. Connected with him is Captain Ferber, an officer of the French army, who has been foremost in aeronautical matters for ten years. Levavasseur took up aeronautics fifteen years ago, designed a light engine for his flying machine and was bluntly told by everybody that he was mad. Nobody being willing to give a cent for his engine for aeronautical purposes, he put it into a motor boat, beat all European records, and when his engine had won fame went back to aeroplane construction.

In the new two-passenger flying machine Levavasseur has built what may be roughly described as a long, narrow boat, has fitted two wings, a lateral and a vertical rudder at the stern, and placed his engine right forward in the bow, where it drives a two-bladed aluminum and steel propeller.

The resemblance with a boat is striking, for the bow is sharply pointed, the craft broadens out amidships and narrows slightly toward the rear. It is decked over with the exception of the forward portion reserved for the power plant and a cockpit to be occupied by the steersman. Instead of a wooden or steel skin, however, the craft is covered with canvas, treated with a coat of waterproof paint, and the deck is of the same style of construction. At the rear is a horizontal rudder the operation of which determines the rise and fall of the aeroplane, and below it is the usual vertical rudder by which movement to the left or right is obtained.

The entire sustaining surface is a couple of light canvas wings 40 feet from tip to tip, attached to what might be called the gunwale. Four men working ten hours a day were six months in constructing this pair of wings, each section of which has been tested to a pressure of one and a half tons.

During the initial trips power will be obtained from an eight-cylinder water-cooled Antoinette engine of 60 horsepower; a little later, however, this will be replaced by a sixteen-cylinder

engine of the same make declared to develop 120 horsepower at 1,200 revolutions a minute. Water for the engine is carried in a couple of copper tanks immediately above the angle formed by the V-arrangement. Later a radiator will be fitted, giving a reduction in weight and allowing the engine to be run for a much longer period than is now possible with the tanks. The gasoline supply is carried in a cigar-shaped tank in the bow, this part of the power plant being all that is visible when the aeroplane is viewed from the ground. Steel cylinders of 4-inch bore and stroke, fitted with copper water jackets, are the feature of the new engine. There is neither flywheel nor carbureter, and ignition is by high-tension Bosch magneto.

Drive is direct from the engine to the two-bladed propeller in front of the aeroplane, the speed of which will therefore be 1,200 revolutions per minute. It is estimated that the aeroplane will leave the ground at a speed of 30 miles an hour, and that its rate of aerial travel will be 54 miles an hour. With the present water and gasoline equipment it will be possible to stay aloft half an hour. Engineer Levavasseur, however, declares that within five months this machine will have remained in the air two hours without touching ground. As if to prove that the aeroplane is intended for long-distance travel, a light awning had been rigged up to give protection from the sun for the well in which Captain Ferber will have his seat. The mechanic, squatted further forward with the engine in front of him, has not been the object of such attentions.

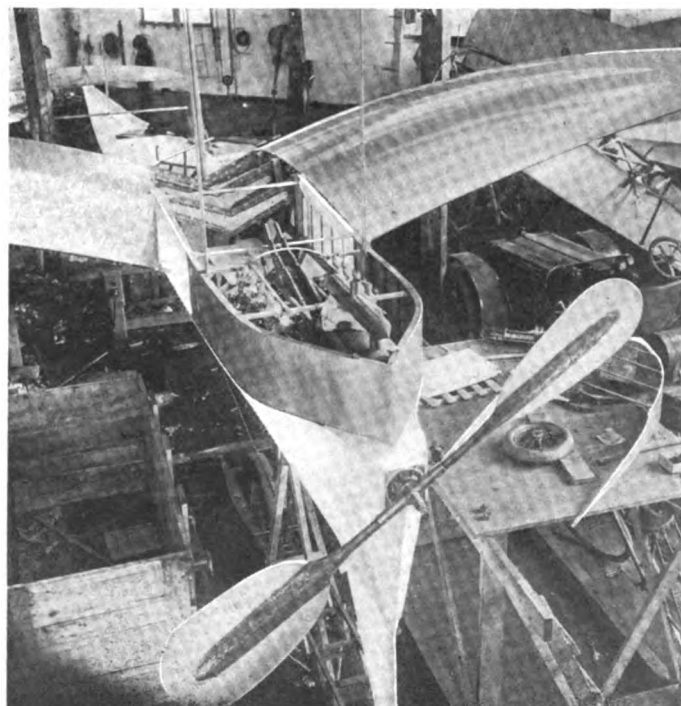

Ferber Aeroplane, of Boat Type, to Carry Two.





The Beautiful Mansion on the Place de la Concorde, Paris, the Home of the A. C. F.

IT is now exactly thirteen years ago—February, 1895—that a mere handful of autoing enthusiasts held, at Marquis de Dion's private residence in Paris, a meeting out of which came the foundation of the Automobile Club de France. Little did they think that such a powerful organization would emerge from what they thought at that time would be a mere local and social club. The automobile was then in its infancy, and what few "horseless vehicles" were to be seen elicited more mockery than applause or interest. Among those present at this historical meeting such names as those of Baron de Zuylen, Pierre Gifford, Marquis de Dion, Paul Meyan, Count Récopé may be mentioned. As may easily be inferred, the discussion was a friendly one, and before the day was over the Automobile Club de France had started what was to be an eventful career. A unanimous vote carried Baron de Zuylen to the presidency, and it is a remarkable fact to record that this gentleman has held the position ever since.

A few weeks after, the A. C. F. inaugurated its first clubhouse, which was beautifully located on the Place de l'Opera, right in the center of the town. And the new association began to grow fast, each committee meeting having to ballot several dozen candidates.

Nobody expects me to write here the history of the automobile in France and its extraordinary development. One would have to do so in order to follow the A. C. F. along its course of prosperity, as both histories only make one. As a matter of fact, nothing worth recording has happened in automobile matters in France since 1895 without the club playing an important part in it.

Before one year had elapsed after the foundation, the membership had reached 300, and two years later it was deemed necessary to move to larger premises. After much discussing and negotiating a place was found which enabled the A. C. F. to rival with any club or association throughout the universe in the matter of a clubhouse. Every one will agree with me that no finer place could be found than the beautiful mansions occupied by the A. C. F. on the Place de la Concorde, and which, by the way, are now the property of the club, a syndicate headed by Baron de Zuylen having made its acquisition and allowed the club to pay for it on the installment plan. The building comprises five stories and includes everything that one could expect to find in a modern clubhouse. Outside of big and luxurious restaurants, lounge, smoking and billiard rooms, library, and large meeting rooms, there is a magnificent hall used for festivities and also a regular theater with all stage and machinery

fittings, where about 800 people can be seated in boxes and orchestra seats.

The actual membership of the A. C. F. is 2,300, and the annual subscription is 200 francs (\$40), with an entrance fee of a similar amount. A few words about the organization or constitution of the Automobile Club de France will not be out of place here. It has been vastly altered since the days of the foundation, so as to cope with the growth and developments of what has become much more than the mere pastime it was at first. The A. C. F. is now divided into two parts, which remain distinct as far as administration is concerned. They are: first, the social club proper or "Circle," which is merely the same as an ordinary club; and, second, the promoting association or Societé d'Encouragement," whose aim is the general development and protection of the automobile industry, sport and pastime, and the promotion of races,

contests, trials, shows, or any other event liable to further or favor same.

It may seem strange to state, however, that no member can belong to any of the allied associations without also joining the other. The reason of a nominal division is obvious. While the "Circle," being considered as a purely sumptuary organization, has to pay heavy taxes, the "Societé d'Encouragement" escapes these on account of its object and is, therefore, able to handle a lot of money and receive or expend big amounts.

A committee of fifty members manages the "Circle," and as its organization is pretty much the same as that of all clubs, there is little to say about it.

#### Managed by Committee of Fifty.

The constitution of the "Societé d'Encouragement," which, to foreign eyes appears and is really the A. C. F. itself, will be found much more interesting to study, and I propose giving here a full explanation of same. It is managed by a committee of fifty members, who elect in turn among themselves a board of nine directors, which governs the association and represents it in all circumstances. At present this board of directors or acting committee is made up as follows: President, Baron de Zuylen; vice-presidents, Marquis de Dion and Mr. Henri Menier; treasurer, Mr. Dehideux-Vernimmen; members, A. Ballif, Marquis

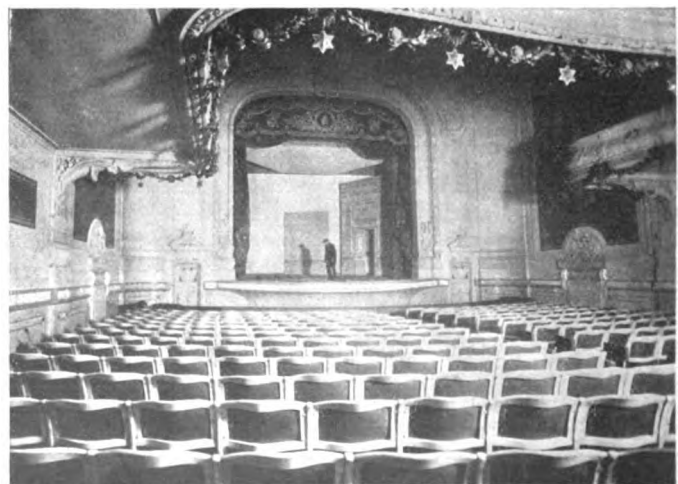

Private Theater of the Automobile Club of France.

de Chasseloup-Danbat, Count de la Valette, Count Récopé and Gustave Rives. It may be here stated that there is no secretary on the board, since the secretarial work is done by a paid official, who, at the same time is at the head of the offices of the club. An idea of their importance can be gathered from the fact that no less than 25 clerks are employed by the various "commissions" or sub-committees, irrespective of the footmen and livery division, which numbers no less than 70 people. By the way, the restaurant of the A. C. F. is known among the best in town, and its *chef* draws a princely salary, having twelve men or boys in the kitchen under his orders.

But we must return to our "commissions," as these represent one of the most remarkable parts of the system under description. Now it will be easily understood that in such a powerful organization, having to deal with so many different questions, the task of the members of the board would be simply an impossible one should they try to personally confront every problem. Therefore, as the field of actions grew larger, and the A. C. F. scope of influence widened, it was found necessary to

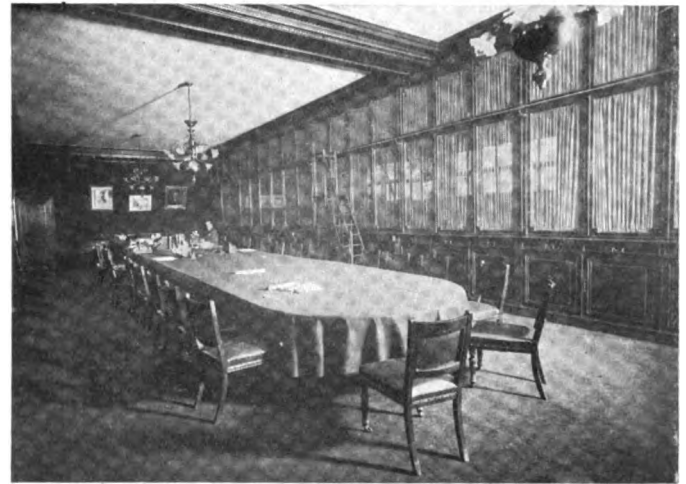

The Library, Ample and Well Stocked with Books.

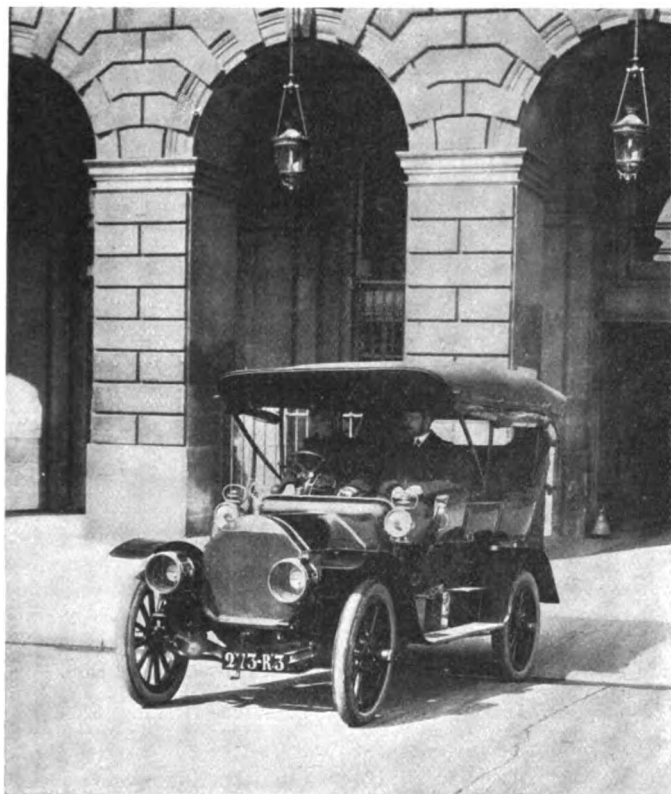

Samuel A Miles and W. F. Bradley Visit the A. C. F. in the Pierce Great Arrow.

form sub-committees, or "commissions," as they are called in French, each of which was entrusted with a special subject. They number at present eight, viz.:

**Eight Powerful Commissions.**

(1) Commission des Concours et Fêtes Exterieures, which has in charge the promotion of all trials and contests which are not of a purely sporting character; that is, in which speed is not the essential factor.

(2) Commission des Relations avec les Automobile-Clubs de Province, which, as can be gathered from its name, corresponds and deals with provincial clubs.

(3) Commission du Contentieux, which deals with law and judiciary questions.

(4) Commission des Expositions, which has in charge the promotion of shows generally, and the big annual Paris show particularly.

(5) Commission Technique, dealing with all subjects of a purely technical order.

(6) Commission de Tourisme, devoted to everything connected with touring and questions relating thereto.

(7) Commission du Yachting Automobile, whose name explains itself.

(8) Last, but not least, the Commission Sportive, having the upper hand over purely sporting questions and whose chief work is the annual promotion and organization of the big annual speed contest known the world over as the Grand Prix de l'Automobile Club de France.

A remarkable fact about these various commissions, and more especially about the last named, is the almost unlimited power they have developed in the life and history of the A. C. F. Now, it would seem that they are to all intents entirely under the dependency of the board of directors, since they are formed by the said board, and could be suppressed by a decision of its members at any time. Be it as it may and explain it as you can, the fact is that these subcommittees have got to be entire masters of their line. Many a time have they taken or advocated measures which were not in harmony with the committee's idea, and the latter has invariably yielded to them. This peculiar situation is more remarkable with the Commission Sportive, whose members are very independent in their ideas, and the on-looker can even ask himself what would happen if the committee ever insisted on ruling over any of the commission's decisions.

**Commission Sportive Of and For the Industry.**

Now, to foreign eyes, this Commission Sportive represents, therefore, the A. C. F. itself to a great extent. It is the one which has the biggest international prestige in the French club, and one must admit that it fully deserves it on account of the pains taken by its leaders and of their undoubted abilities in the

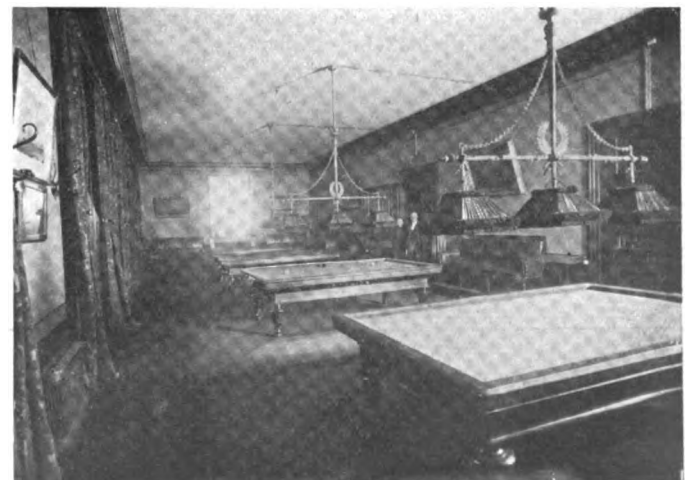

Where the Members Enjoy Themselves at Billiards.

work they perform. Therefore, it will be found interesting to devote here a special study. The president of this sub-committee, which, in many ways eclipses the committee itself, is Chevalier René de Knyff, and the vice-president, Count Robert de Vogué, two of the best-known figures in international motor matters. The list of members is as follows: Prince d'Arenberg, Henri Brasier, Etienne Girard, Georges Huillier, Count de la Valette, René Doysel, Guinonet de Léon, Louis Renault, Baron de Turckheim, while Messrs. Clément, Gobron and Bocandé are also entitled to a seat as delegates of the Chambres Syndicates, or makers' association. Now the observer cannot help being impressed by the fact that this board which practically controls and manages motor racing in France is almost entirely made up of trade representatives, and, what is more, of the biggest firms and concerns.

A perusal of the above list would show that Panhard, Brasier, Charron, Renault, Dietrich, Clément and Gobron are all represented either by their heads or by some people holding prominent positions in the firm. Indeed, out of the above 14 gentlemen, not more than four have no direct connection with the trade, and even then some of these four are known to hold some financial interests in same.

It will not, however, surprise many people to hear that the big success of the French racing generally can be put down to the good work done by such competent people. The old saying, "have millmen in the mill," is ever true.

To close up with this article on the big French club, a few words must be said here of its prominent part in the promoting of the annual Salon, or show. Thanks to the efforts of G. Rives, who is past master in this line, the A. C. F. comes in every year

for a big share of the profits made in this enormous and world-famed enterprise. This is what enables the club to carry on an expense list worthy of its reputation.

And if I had to name another reason for the success and prosperity which has marked the career of the Automobile Club de France, ever since its inception, I would put it down to the remarkable spirit of concord and alliance which has always animated its leaders.

### SOME FOREIGN OBSERVATIONS BY S. A. MILES.

From S. A. Miles, general manager of the N. A. A. M., who is now touring Great Britain and the Continent with a Pierce Great Arrow, comes a few observations:

"I have been greatly impressed by the enormous number of 'buses and cabs in use in London. Horace Bell, who is well remembered in the States, is the manager of the cab company, which has 505 cabs in operation. These cabs run at 20 miles an hour through the traffic, and are, I should say, the greatest advertisement the motor car has ever had. The 'buses are less noisy and less frequently disabled than when I was last here.

"The touring facilities available in London at the headquarters of the Automobile Association are most excellent. Just at present there is a row on between the A. A. and the Royal Automobile Club, a lordly thing which seeks to enjoy the power of veto, etc., over which the rank and file is rebelling.

"To accomplish the general good of automobiling, organizations must be good in character, and this holds good both on this side of the water as well as in America.

"I am looking forward to some most enjoyable touring."

## GRAND PRIX DES VOITURETTES WILL BE POPULAR EVENT

PARIS, May 1.—Without claiming to be a prophet, one may put forth the statement that the voiturette Grand Prix, to precede the international race on the Dieppe circuit next July, will be one of the most popular events ever disputed in France. The fact that out of the 60 cars only six are foreigners does not appear likely to have any influence on the public estimation of the race; probably, indeed, it will enhance the value in the eyes of the natives. During the past eighteen months or two years France has certainly got rid of the idea that the *car de luxe* is the only interesting article in the automobile world, and, once free from this illusion, has plunged into the small car or voiturette field with unbounded enthusiasm.

There is no similarity whatever between the French voiturette and the small cars which dealers in this country are afraid American constructors may ship over in huge quantities at any moment. It is a distinctly home product which public taste and racing regulations have developed on certain fixed lines.

For the "Grand Prix des Voiturettes," as for the similar but privately organized contests for runabouts, 3.9 inches for a single-cylinder engine has been fixed as the maximum bore; for two, three, and four-cylinder engines the cylinder bore is proportionate, stroke being unlimited. It is a diminutive power plant that is carried under the bonnet of the small cars, smaller, I believe, than any produced by the better known American factories. Ford, indeed, who is now well represented in France, is altogether too big to come into the race with his small cylinder runabout, and, according to Henri Depasse, the Paris agent, this popular American firm will not construct a baby four-cylinder of 2.4 inches bore.

According to all the information at present available, Isotta-Fraschini, and Pilain, the one Italian and the other French, will be the only two firms entering four-cylinder cars under the limited bore of 2.4 inches. There will be no three-cylinder engines, and probably not more than 25 per cent. of the entrants will have two-cylinder engines measuring 3.07 inches bore; the great majority will be single-cylinder cars with the maximum bore of

100 millimeters, the single-cylinder type having sprung into unusual favor since the inception of the voiturette class.

In every case the voiturette racers follow the general disposition of the large cars, the power plant being forward under a bonnet, transmission being through sliding gears, and final drive generally by cardan shaft and live axle. There is not a car constructed in France with the motor under the seat, under the body, or at the rear, and there will certainly not be a single vehicle in the voiturette race which will differ externally—except of course in size—from the mile-a-minute racing cars.

### Features of Some of the Undersized Racing Cars.

The undoubted favorite in the runabout race is Sizaire-Naudin, the victor in the voiturette contest of last fall. New Yorkers had an opportunity of studying the external features of the firm's production in the New York-Paris contest, when Pons made a little run up-State on a Sizaire and retired with a broken differential. For the Grand Prix three single-cylinder cars have been constructed, all with the maximum bore of 3.9 inches, and stroke of 6.2 inches. As the team is quite ready it is probable that the machines will be run in the Targa Florio preparatory to competing on the Dieppe circuit.

At the normal engine speed of 1,700 revolutions a minute the small power plant develops 16 horsepower on the brake and is geared to run at 12, 18 and 39 miles an hour at 1,500 revolutions a minute. As the engine can be accelerated up to 2,200 revolutions a minute, the speed of the car will be over 50 miles an hour under favorable conditions. Among the few changes which have been made since last year's models is the increase in weight of the moving parts in the engine. The piston and connecting rod last year were of especially light construction and were found to have a certain amount of flexion. The extra weight which has been put into these parts has tended to increase the efficiency of the engine, according to the factory experts. Valves are superimposed, the inlet being operated by an overhead rocker arm. Overhead valves, indeed, will be a feature of both the

Grand Prix and voiturette racers, a large number of the cars also being fitted with hemispheric combustion chambers.

High-tension magneto, of Bosch manufacture, supplies the current for the Sizaire-Naudin. In this respect there is a remarkable uniformity among the small racers, the number of those obtaining their current from storage batteries, or even carrying storage batteries as a stand-by not exceeding five per cent. The engine is water-cooled, with circulation by thermo-syphon. Here again there is uniformity, not a single air-cooler being entered. Regarding the value of a pump small car constructors are not entirely of one mind, though thermo-syphon systems of water circulation are in a majority in the cars presented for this contest.

In suspension, transmission and drive Sizaire-Naudin has worked on independent lines. Thus the fore part of the car has a single transverse spring having a certain resemblance to that of the Mora; the rear suspension is by means of reversed semi-elliptic springs, the rear ends of which are attached to the axle. A metal disc clutch transmits the power through a propeller shaft to a gear box on the rear axle, where three speeds forward and one reverse are provided, all the forward speeds being on direct drive. Instead of the exhaust being carried to the rear below the chassis it is brought out through the box behind the mechanic seat, giving the rear of the car very much the appearance of the stern of a motor boat.

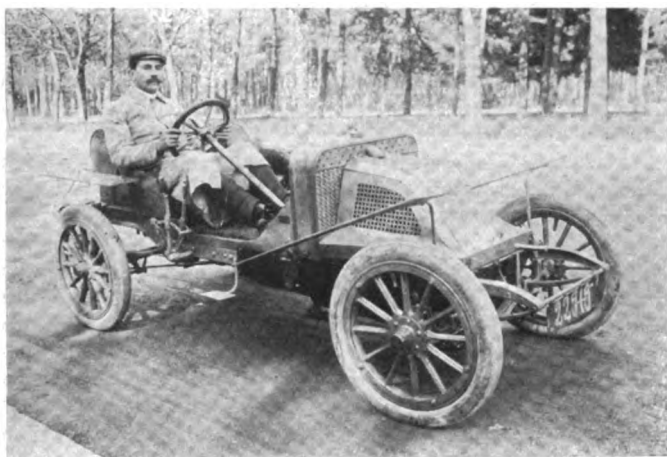

The Passe-Partout, One of the Voiturette Race Candidates.

Gregoire, one of the two-cylinder champions, has three cars of this type, each one with a bore of 3.07 inches and stroke of 5.9 inches. Changes from the standard type of engine constructed by the firm are overhead valves, commanded by rocker arms, and dome heads, the plugs being placed laterally just below the inlet. The crankshaft is offset ten degrees. Standard lines are followed in the sliding-gear transmission and final drive by rear live axle. A special feature, however, is the parallelogram suspension of the cardan shaft. With the radiator well behind the rear axle, the seats completely encased in and the rear in turtleback form, the little car has all the features of a racer, and a fast one at that.

Isotta-Fraschini and Pilain, the two firms entering four-cylinder cars, have both built engines with cylinders in one casting, dimensions for each being 2.4 bore by 3.9 stroke. Both have ignition by high-tension magneto, the French car being equipped with a Nilmelior and the Italian with a Bosch; the Pilain is one of the few cars having a double system, accumulators of course only being used to start up or as a stand-by.

Only one make of car in the race is fitted with side chains, European constructors generally believing that the shaft is the *dernier mot* in small car construction. Lion-Peugeot, however, had sufficient success in the last voiturette race, when all three cars had double chain drive, to convince them that it would be good for the Grand Prix. Foullaron employs a belt drive

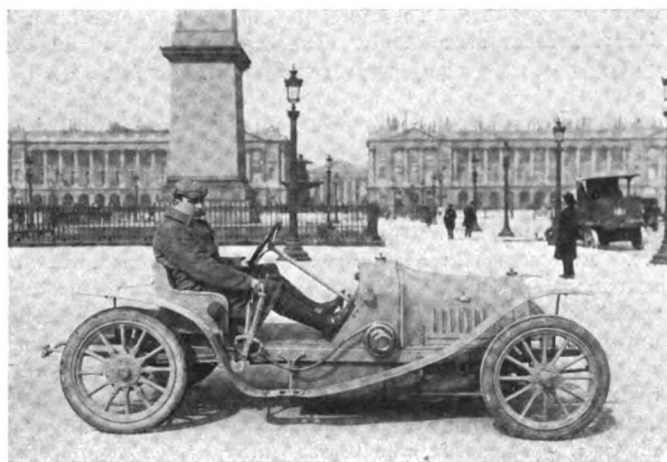

Foullaron Voiturette Candidate and Driver Grillet.

with a patented system of extensible pulleys, which, though successful under ordinary touring conditions, is not looked upon seriously for a race. All other constructors that are entrants in the race, have shaft-driven cars.

### LONDON HAS NEW TAXICAB RULES.

With a view of ameliorating grievances complained of by the patrons of taxicabs in London, the commissioner of police has issued the following regulations, which, it is expected, will relieve congestion and improve the service:

- (1) The drivers of the first two motor cabs must be with their cabs and be ready to be hired at once by any person.
- (2) All cabs on the standing must move up as vacancies occur.
- (3) No motor-cab engaged for some future time shall remain on the standing, unless willing to accept any intermediate hiring that may be offered.
- (4) No disabled motor-cab shall remain on the standing unless such disablement is strictly temporary, and can be, and is, remedied at once. If the disablement is not of such a nature, a notice (in a form to be approved by the commissioner) must be at once placed on the cab to the effect that it cannot be used, and will be removed for repair.

### PERMANENT SHEDS FOR THE PARIS FLYERS.

PARIS, May 1.—On the Issy-les-Moulineaux ground permanent aeronautical sheds for the proper housing and care of aeroplanes are being built by special permission from the war authorities. Previously all sheds were flimsy wooden structures on the outside of the wall surrounding the military drill ground and adjoining the newly-erected bar which its proprietor, with an attempt at English, has named the "Aerot's Bar." The new sheds, in wood and plaster, are on the drill ground itself, and will offer much better facilities for entering and leaving.

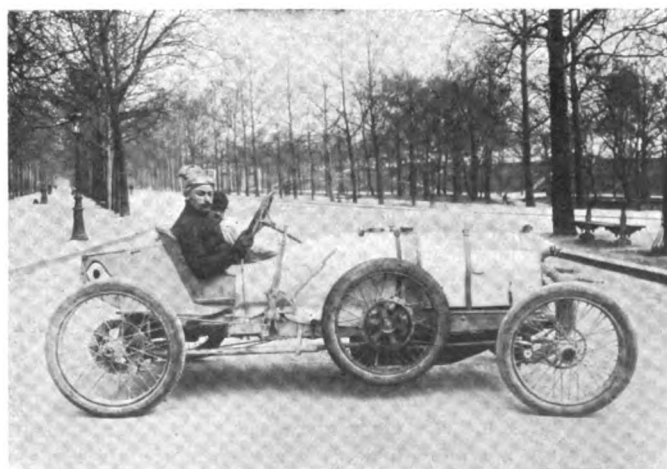

Sizaire & Naudin Voiturette—Driver Sizaire at Wheel.



# FRENCH MAKERS OBJECT TO VANDERBILT CUP RULES

By W. F. BRADLEY.

PARIS, May 1.—French automobile constructors are almost unanimously of the opinion that the Racing Board of the American Automobile Association has been wasting its time in the determination of weight limits for the next Vanderbilt Cup race. Automobile France argues that America accepted the international racing rule adopted at the Ostend conference and ratified at the Paris conference, and that the plain duty of the United States is to abide by those regulations. All constructors with whom I have spoken on the subject declare that they are unable to understand the necessity for any change in the weight limits, even those adopted not being in accordance with the Ostend standard, which was fixed at 1,100 kilograms minimum, without water, tires, tools or spare parts.

Not only are individual members of the trade dissatisfied with the Vanderbilt draft received, but the Automobile Club of France has raised its voice in official protest. At the last meeting of the Racing Board it was decided to oppose the adoption of the outlined Vanderbilt rules, on the ground that America, as one of the contracting parties, was bound to the international conditions.

In order to get inside information on the matter, THE AUTOMOBILE correspondent called upon M. René de Knyff, chairman of the Commission Sportive of the Automobile Club of France, and asked for his views on the matter.

## What Chairman De Knyff Has to Say.

"You will understand what we feel about the matter," declared the pioneer French automobilist, "when I tell you that an official protest has been drawn up and will be sent by the next mail to the Automobile Club of America. At the same time a copy of the protest will be sent to every club connected with the international conference.

"Our grounds for protest? They are that an international rule was agreed to at the Ostend conference, that America approved it, and that every nation taking part in that conference is under an obligation to hold no race for cars exceeding a bore of 155 millimeters.

## Neither American Delegate Attended Ostend Meeting.

"Though invited, I believe neither of the American delegates attended the Ostend meeting, at which after a long discussion we agreed to hold no races in 1908 except for cars of a bore not exceeding 155 millimeters, and of a minimum weight of 1,100 kilograms. At the November meeting in Paris the American delegates were present and agreed to these rules. Now we are informed that America intends to break away and cause constructors to build an entirely different set of cars."

It was pointed out that the disruption between the A. A. A. and the A. C. A. might be considered as nullifying the agreement so far as America was concerned. M. René de Knyff appeared to be puzzled by the nomenclature and admitted that the only association that was familiar to him was the A. C. A.

"But put aside this question of clubs. I suppose the object of the American Racing Board and of Mr. Vanderbilt is to make a success of the Vanderbilt Cup event. How can you do it if you persist in adopting a rule that keeps out all European cars? Expenses in connection with a race are frightfully heavy, and it was entirely with a view to diminishing them that the national clubs got together and decided on a common basis for all the great speed tests. You cannot expect us to build cars specially for the Vanderbilt race, and to compete with our 155 millimeter machines against cars of 170 or 180 millimeters would be folly. The American board is two years behind the time, for it has adopted the rules that were in vogue for the first Grand Prix on the Sarthe in 1906."

"Do you intend to combat the Vanderbilt conditions?"

"Most certainly. As a club we shall refuse to have any connection with the race if the international rule is not adopted. We cannot prevent French constructors going over to America and competing if they wish to do so, but we can refuse to help them, and we shall certainly wash our hands of the whole affair if America refuses to live up to her agreement."

"Some American cars are already built? Well, that is a pity, but there cannot be many of them, and I know that Mr. Vanderbilt and Mr. Thompson are such thorough sportsmen that they will not allow a mistake or a misunderstanding to give two or three firms an unfair advantage over the entire world. Of course if Mr. Vanderbilt wants his race to be for American cars only, let him stick to the proposed rules, and I am certain his wish will be gratified. But, quite apart from obligations, if you want to make the American event a success, you will certainly have to adopt the rules of the Ostend conference. Our Sarthe cars are gone, who knows where, and we do not want to build any more of that type."

## Delegate Hogan Tries to Explain Complications.

W. S. Hogan, one of the delegates of the Automobile Club of America, seen at his office in the Avenue Kleber, at once confirmed the statements of M. René de Knyff regarding the obligation of America to submit to the international rule.

"Personally I was not present at the Ostend international conference, and was not even notified to attend. If the A. C. A. did send a notice, it certainly did not reach me. To the best of my knowledge my colleague, Howard Johnston, was not present either. When I heard that such important business had been enacted I was sorry I had not received a copy of the program, for in that case I should have attended, whether convoked or not.

"At the international conference held in Paris, November 21 of last year, both Howard Johnston and I were present. Our instructions from the A. C. A. were to act as we thought best, and we consequently voted the ratification of the Ostend rules. The conference was attended by every recognized national automobile club, and the vote was unanimous. In my opinion the only sensible policy was to adopt the uniform rule; times are now too strenuous in all countries for money to be squandered on the construction of half a dozen sets of racers each year. Builders in every country in Europe want a rule which will allow them to build one set of cars per annum and to race them in every country holding a long-distance speed test.

"The conclusion of the matter is that the American club, having given us the power to act, is under an obligation to abide by the contract, and though I know that differences have arisen between the A. C. A. and the A. A. A., that should not prevent the Ostend rule being adopted for the Vanderbilt Cup race."

## What the Minutes of the Meeting Show.

According to the minutes of the November conference it appears to have been thoroughly understood that no nation should hold a speed test under any other rules than the one decided upon at Ostend. The Belgian delegate in his remarks stated that it was not the intention of the conference to forbid the holding of races for smaller cars, but that no races should be held for machines more powerful than those under the Ostend rule.

A visit to the office of the International Association of Recognized Automobile Clubs, which has been put on a more permanent basis as a result of decisions taken at the November meeting, brought forth the fact that neither of the American delegates was present at the Ostend meeting. A letter was received from President Hoyt, just before the conference, asking that the A. C. A. members be excused. Both delegates, however, were present at the November conference, as the official minutes show, and voted in favor of the international racing rule.

## NO VANDERBILT RECOGNITION SINCE A. C. F. KILLED BENNETT

IN view of the fact that the Automobile Club of France, immediately after interring the Gordon Bennett race in the winter of 1905-06, practically disregarded any further communications in reference to the Vanderbilt Cup race, classing it as a similar event, the comments of Chairman De Knyff read somewhat humorous. He states: "As a club we shall refuse to have any connection with the race if the international rule is not adopted." As a matter of fact the Automobile Club of France has had nothing whatever to do with the Vanderbilt Cup race for several years past, declining in 1906 to designate officially the French entrants as representing the club and France.

In 1906 the Vanderbilt Cup Commission arbitrarily named the five French cars, Chairman Jefferson deMont Thompson, while in Europe and in attendance at the Grand Prix, making arrangements for the French entries in the race for that year.

France made the Gordon Bennett an impossibility because it did not desire to limit its makers to a team of five cars when any other country, no matter how small, could have a similar number. It was for this reason that it withdrew its recognition of the Vanderbilt event.

It is a certainty that there will be French contestants in the next Vanderbilt race, several firms having stated that they would enter cars no matter if the 1908 international conditions were not adopted. Germany is certain to be represented, England is a possibility, and it is more than likely that Italy will not lose her prestige by remaining out of the fray.

While it is admitted that international rules should be in effect for all big road races, circumstances made this practically an impossibility for the 1908 Vanderbilt race. Furthermore, the manner in which the A. A. A., the governing body of automobile racing in this country, has been represented in the councils of the International Association of Recognized Automobile Clubs has been careless, to say the least. The A. C. A., as a matter of courtesy through its having been the first club formed in this country, was continued by the A. A. A. as a spokesman of the country, but it is a recognized fact that its manner of looking after the interests of the A. A. A. has not been entirely conscientious. The A. C. A. has never troubled itself to make any report from time to time to the A. A. A., and the latter apparently took it for granted that there was nothing to report upon. Until this misunderstanding over the 1908 conditions came about, the matter of international relations occupied slight attention.

Unquestionably there has existed in Europe the impression that the A. C. A. was the direct and duly authorized spokesman

of the United States, the existence of the A. A. A. being imperfectly known. The present discussion will bring forth the exact situation, and it is reasonable to suppose that the A. C. A., no longer being a part of the A. A. A., will suggest to the foreign



Vanderbilt Plaques to the A. C. F.

To the Automobile Club of France, in recognition of its victories in three Vanderbilt Cup races, W. K. Vanderbilt, Jr., some time presented to that organization a trio of bronze plaques. That of 1904 tells of the victory of Heath driving a Panhard; for 1905, Hemery, driving a Darracq; and for 1906, Wagner, driving a Darracq. These plaques adorn the walls of the club's house in Paris.

clubs that they deal directly with the A. A. A. as far as racing is concerned. This would seem to be a logical sequence, though there are those in this country who believe in the framing of our own rules and leaving it up to the foreign makers as to whether or not they care to participate in our events.

## CONNECTICUT'S ATTITUDE TOWARD VANDERBILT CUP RACE

HARTFORD, CONN., May 4.—The principal topic of local conversation is the possibility of holding the Vanderbilt Cup race in Connecticut. It is much desired that the big race take place in this State, for, measured in dollars and cents, it means that a vast sum of good money will come into the State. But there is another side to the question—the law. The present automobile law in force in Connecticut is one of the best in the country, and all speeds are abolished up to 25 miles an hour. To bring about this measure, considerable hard work was necessary on the part of the autoists and clubs. When the next legislature convenes it is possible that an attempt will be made to put in force a substitute measure.

The law in force very clearly defines that no races shall be held in the State, and the best legal talent holds that this point cannot be dodged and that nothing short of a special act of the legislature would permit the holding of the Vanderbilt Cup race in Connecticut. Yet it is claimed that the governor himself has

stated that he sees no reason why this race should not and could not be held in Connecticut. To make a long story short, if it is possible to have the race here, it is much desired, but if it has to be in defiance of the law, it can work no material good.

It would be far better to see the Vanderbilt Cup event go to Savannah, or to some other city, than to have it come to the Nutmeg State and be the cause of the repeal of the present liberal law. It is too great a sacrifice, not only for the people of the State, but those of other States, New York, for instance, New Yorkers do not find it at all congenial to tour through New Jersey, yet they have some show in Connecticut, and it is desired that present conditions prevail for all time, if possible. "Let us have the Vanderbilt, if possible, but not at the cost of our automobile law," is the slogan. As for courses, there are any number that could possibly be chosen and some of them would be through the smaller towns where there would be no likelihood of interruption from street traffic.

# THE AUTOMOBILE

Vol. XVIII

Thursday, May 7, 1908

No. 19

## THE CLASS JOURNAL COMPANY

Flatiron Building, Madison Square  
New York City

H. M. SWETLAND, President

### EDITORIAL DEPARTMENT

A. G. BATCHELDER, Managing Editor  
R. F. KELSEY, Associate Editor C. B. HAYWARD, Engineering Editor  
W. F. BRADLEY, Foreign Representative

### BUSINESS DEPARTMENT

A. B. SWETLAND Business Manager  
LOUIS R. SMITH FRANK B. BARNETT  
W. I. RALPH, 1035 Old South Building, Boston, Mass.  
C. H. GURNETT, H. E. WESTERDALE, 1200 Michigan Ave., Chicago, Ill.

Cable Address - - - - - Autoland, New York  
Long Distance Telephone - - - - - 300 Gramercy, New York

### SUBSCRIPTION RATES:

United States and Mexico - - - - - One Year, \$3.00  
Other Countries in Postal Union, including Canada - - - - - One Year, 5.00  
To Subscribers—Do not send money by ordinary mail. Remit by Draft,  
Post-Office or Express Money Order, or Register your letter.

### FOREIGN SUBSCRIPTION AGENTS:

ENGLAND:—W. H. Smith & Sons, Ltd., 186 Strand, London, W. C., and all their  
railroad bookstalls and agencies throughout Great Britain; also in Paris at  
248 Rue de Rivoli.  
FRANCE:—L. Baudry de Saunier, offices of "Omnia," 20 Rue Duret, Avenue de  
la Grande Armee, Paris.  
GERMANY:—A. Seydel Mohrenstrasse 9, Berlin.

Entered at New York, N. Y., as second-class matter.  
The Automobile is a consolidation of The Automobile (monthly) and the Motor  
Review (weekly), May, 1902, Dealer and Repairman (monthly), October, 1903,  
and the Automobile Magazine (monthly), July, 1907.

Copies printed in 1905	- - - - -	730,000
" " in 1906	- - - - -	791,000
" " in 1907	- - - - -	888,900

## IN PICKING A VANDERBILT COURSE.

When the residents of any community give up their roads for the purposes of automobile contests, it follows as a natural sequence that there must unavoidably be more or less interference with those citizens who are accustomed to use the highways in the pursuit either of business or for the purposes of pleasure.

Therefore, it appears to be a logical conclusion that it is most unwise to place the venue of a big automobile road contest in the county of any State wherein practical unanimity does not exist as to the use of the roads for high speed automobiling. One never knows what may come up to interfere with presumed arrangements, and the recent Briarcliff event with its eleventh hour difficulties supplies a forcible example.

New York City is the metropolis of the country, and it has a natural advantage in all things, including the supplying of thousands of onlookers to any event which may be scheduled to take place in its vicinity. But it is the presence of these thousands of onlookers which compels in the case of an automobile road contest a most thorough guarding of the course, and this only can be accomplished by the presence of uniformed men and possessing authority to forbid for the moment all citizens other than those engaged access to the road.

If it were possible to complete the Long Island Motor Parkway in time for the race, then the selection of New

York City would be a foregone conclusion. But one thing and another has delayed work on the parkway, uniformed men seem an utter impossibility, and gradually hopes are fading away for a 1908 Vanderbilt race in the metropolitan district.

In looking elsewhere for a course, the Vanderbilt Cup Commission is naturally seeking a locality where the residents are entirely favorable and where proper policing of the course is assured. It is an easy matter to pick out roads, and various States can supply excellent stretches of highway. It is another thing to have a unanimous invitation and the certainty of the essential policing. Savannah up to date has given the most substantial guarantees of the several bidders; in fact, is the only applicant that has come forward prepared and ready to do business without equivocation. Connecticut has been mentioned frequently of late as a possible scene for the big international road race. Now it appears that the automobilists of that State are not all of the same mind, and the existing law is quoted as absolutely forbidding such a contest. Connecticut is favored with a most excellent law, liberal in its provisions, but prohibitive in reference to road racing. One can hardly blame its autoists for not running the risk of a revision of the present law, even for the Vanderbilt Cup race.

But the race will be held; Savannah seems to be entitled to an early answer: and there will be a sufficiency of foreign participants, even though the French makers find fault with our non-acceptance of the international racing conditions of the year. We have always raced according to their ideas; now it is their time to race according to our ideas, or refuse to play in our yard. It's pretty good guessing, however, that there will be participants from France, and Italy and Germany, and, perhaps, England.



## SHOULD THE CAR BUILDER PROVIDE TOOLS?

Partly as an inheritance from the old bicycle days, when practically every machine was built according to a different standard, and partly owing to the fact that many automobiles still have parts that conform to an exclusive standard, the automobile builder finds it incumbent upon him to supply a certain number of tools with every car that he sells. Ordinarily, these are not confined to a few special spanners to fit those particular bolts or nuts that may differ from other standards, but also include a wrench or two in addition, an oil can and a screwdriver—needless to add, a so-called tool outfit wholly inadequate to the requirements of the car which it accompanies. If the maker feels called upon to supply a tool kit as part and parcel of every car he builds, it only seems fitting that he should fulfill his duty in this respect by providing an outfit of tools worthy of the name, as well as one that is in keeping with the selling price of the car. Naturally, tools do not actually form any part of the car; it is just as complete and just as ready for the road without them, and the maker is reducing his profit on the car just that much by supplying them. In a case where cars are turned out by the hundred, the expense for tools is no small item, and their cost is kept down as much as possible, but rather than send a \$2.50 tool outfit with a \$2,500 car, it would seem preferable to omit this essential from the equipment.

## A. A. A. GAINS ITS 24TH STATE BODY—BUFFALO CONVENTION

THE twenty-fourth State association was admitted to the American Automobile Association at the meeting of the national organization's executive committee, held at 437 Fifth avenue, New York City, Tuesday last. This body was the Virginia State Automobile Association. By the admission of the Automobile Club of Little Rock a start was made for a State organization in Arkansas. Reports from various State bodies told of added clubs, especially in the Middle West.

It was decided that instead of designating a single day as "Orphans' Day" throughout the country, that the A. A. A. would suggest the second week in June as the best period in which the various clubs may conduct their annual Orphans' days.

Every club in the association will be asked to send three delegates to the good roads and good laws convention, to be held at Buffalo, July 6, 7 and 8, preceding the start of the annual tour for the Glidden and Hower trophies. Because of this event, the June meeting of the executive committee will take place at Buffalo on Tuesday, June 2.

In the absence of President William H. Hotchkiss, who was unable to attend, First Vice-President Speare presided. Preceding the session, there was a meeting of the special committee

in charge of the Buffalo convention, which promises to be the most important affair of the kind ever held in this country. The governors of all the States will be asked to send representatives and a large attendance is already assured.

In connection with the question of good roads, there will be seen roads in actual construction and also demonstrations of the various kinds of road preservatives, including oil, coal tar and other preparations. Practically all the important road machinery concerns of the country will have exhibitions, and the subject of good roads will be thoroughly covered.

George C. Diehl, county engineer of Erie county, will be the chairman of this "Committee on Practical Road Construction;" Alfred Reeves will serve as chairman of the committee on publicity, and others well qualified will assist Chairman R. P. Hooper, of the Good Roads Board, and Chairman Charles Thaddeus Terry, of the Legislative Board. The National Grange has promised its hearty support, and the president of this big organization, ex-Governor N. J. Batchelder, of New Hampshire, will be one of the speakers. The delegates will be entertained in various ways and work on the various activities is reported to be well in hand.

### JERSEY'S BIG CLUB NOW HAS 816 MEMBERS.

NEWARK, N. J., May 4.—At its annual meeting held to-night the New Jersey Automobile and Motor club discussed the new amendments and voted to stand by the State Association of the A. A. A. in any legal fight it might make to test their constitutionality.

The following officers were chosen: President, Paul E. Heller; vice-president, W. C. Crosby; treasurer, Dr. James R. English; secretary, A. B. Le Massena; trustees, William C. Shanley, H. A. Bonnell, F. A. Crosselmire, Dr. F. B. Meeker and A. G. Scherer.

The club has added 130 members to its roll since the last annual meeting and now numbers 816, taking third place numerically among the automobile clubs of the country.

### PRESIDENT HOTCHKISS TO BAY STATERS.

BOSTON, May 2.—William H. Hotchkiss, president of the American Automobile Association, came to Boston to-day by invitation of the Massachusetts State Association for the purpose of making an address before the members at the American House. The audience was thoroughly representative, and included two former presidents of the A. A. A., Messrs. Whipple and Lee; First Vice-President L. R. Speare, and representatives of the Wachusett, Springfield, Worcester, Bay State, Malden, and other automobile clubs affiliated with the State association.

President Hotchkiss laid much stress upon the advantages of cooperation among the automobilists of the country, and told of how much more can be accomplished in this way than by purely individual or club effort.

## SELDEN FIGURES THAT TELL INTERESTING STORY

TRENTON, N. J., May 4.—The hearing of the petition of the receivers for the defunct Electric Vehicle Company, Halsey M. Barrett and Henry W. Nuckols, regarding the signing of a new arrangement by the Selden licensees with regard to a reduction in the percentage of royalties they are paying, which was to have come before the United States Circuit Court here this morning, has been postponed for two weeks. In the meantime, some interesting facts and figures have come to light. It will be recalled that the receivers state in their petition that the licensees regarded the royalties as excessive long before they refused to pay further amounts to the receivers.

It seems that since the formation of the licensed association the gross royalties paid to the Electric Vehicle Company have amounted to \$1,893,608.93, of which George B. Selden received \$391,333.88, while the E. V. Company's net portion was \$682,274.64, the licensed association receiving \$820,000.41. Here are the figures for the past five years:

	Gross Royalties	Paid to	
		G. B. Selden	E. V. Co.'s Share
1903.....	\$153,783.55	\$33,372.96	\$39,859.05
1904.....	253,273.42	51,762.92	86,435.53
1905.....	413,958.31	79,747.49	150,116.01
1906.....	564,535.24	114,100.67	217,683.56
1907.....	508,058.41	112,349.84	188,180.49
	<b>\$1,893,608.93</b>	<b>\$391,333.88</b>	<b>\$682,274.64</b>

As the result of the failure to modify the agreement regarding the extent of royalties paid, there was a general refusal to continue payments, so that for the quarter ending January 1, 1908, only twelve of the members rendered the usual statements of their business, and only half of this number paid the royalties, so that for the last quarter of 1907 only \$23,779.65 was collected, while for the first quarter of 1908 the receipts were but \$8,828.26. The receivers have considered the advisability of enforcing the royalty agreements by suit, but as the licensees are situated in so many different jurisdictions the plan was deemed impracticable, and a modification of the tariff decided upon. George B. Selden has also certified his willingness to accept \$60,000 a year as a maximum, while the maximum the E. V. Company is supposed to receive annually amounts to \$150,000.

It is hardly considered likely, however, that the mere reduction of 20 per cent. in the royalties payable will be the panacea that the receivers consider it, as if there has been an almost unanimous refusal to pay 1 per cent. on the catalogue price, the chances of collecting 8-10 of 1 per cent., which is the new basis proposed, do not seem overbright. It is thought that the final outcome of the affair will be the sale at auction of the patent licenses in order to make some attempt at reimbursing the 400-odd creditors of the Electric Vehicle Company, whose only source of income is the Selden patent.



## OHIO'S A. A. A. STATE BODY OBTAINS THE UNIFORM LAW

CLEVELAND, May 4.—After many wearisome delays, dis-appointments, and reverses, the Motor Vehicle bill drafted by the Ohio State Automobile Association of the A. A. A. has been put through the legislature, and is scheduled for signature by the Governor before this is off the press.

When the news was given out that hereafter Buckeye autoists would enjoy State registration, together with the many blessings in the way of regulations which the bill provided, there was considerable rejoicing, not only in this city, but in Cincinnati, Akron, Columbus, Youngstown, Marietta, Lima, Springfield, Toledo, Elyria, Kenton, and many other cities and towns where there are auto clubs affiliated with the State body.

By far the most important clause contained in the bill is the one which makes fast driving *prima facie* evidence of recklessness. On the face of it, this appears to be drawn up for the benefit of the ruralites only, but it was copied from the Connecticut bill, which is admittedly one of the best in the country, and under which it is almost impossible to operate speed traps or to unjustly persecute motorists. In simple English, this clause of the bill works out in this way: John Smith is going along a country road at twenty miles an hour, and sees in front of him several miles of clear, unobstructed, and unoccupied highway.

He lets 'er go, and while traveling at more than forty miles per his time is taken, and he is hauled before the representative of the law at Squeedunk Corners. Admits going forty miles or better, but claims road was clear and there was absolutely no danger either to himself or any one else. Under the *prima facie* clause of the Motor Vehicle bill it is impossible to secure a conviction in this or similar cases.

Five dollars will be the charge for registration of gasoline and steam cars under the new bill, and three for electrics. Dealers and manufacturers pay a \$10 fee and \$2 for every license number desired. There is no charge for commercial vehicles. Motorists touring in from other States are allowed in this State ten days free—after that they must obtain an Ohio license. All surplus funds, estimated by the Secretary of State to be about \$80,000 yearly, will go for repair and maintenance of roads.

Secretary Forbes, of the Cleveland Automobile Club, and Harry Vail, member of the Legislative Committee of the O. S. A. A., have borne the brunt of the work of getting this measure through both branches of the legislature, while an equal amount of credit is due Senator Ward, of Cuyahoga county, who kindly fathered the bill. Henry H. Hower, secretary of the O. S. A. A., has also done some work at Columbus.

## INCONSIDERATE AUTOISTS MAY IMPERIL CONNECTICUT LAW

HARTFORD, CONN., May 4.—Complaints are frequently made that of late autoists do not observe a reasonable speed in passing through settled communities in the State of Connecticut. The work of a few reckless spirits has been reflected upon the whole motoring contingent, and unless the unruly ones come down to earth and act human the Connecticut law will be a thing of fond memory only. A flagrant instance is that of a young man who races from one town to another just to establish a record that means nothing to any one or even the car itself.

The Automobile Club of Hartford has prevailed upon its members to be reasonable in the matter of speed, and the forthcoming

endurance run was altered so that the average speed in miles per hour was materially lowered in order that the law could be complied with and have a little left to spare. Entries are coming along in good shape, and everything points to the success of the initial venture of the club. After much discussion, it has been definitely decided that all tire troubles will be penalized.

The membership list of the club continues to grow, and at the last meeting of the governing board fourteen more applicants for membership were admitted. The new clubroom in the Allyn House has become popular, not only with the members but with visiting tourists as well. A hill-climb will be held in September.

### AN EDICT OBNOXIOUS TO BOSTON AUTOISTS.

BOSTON, May 4.—The Metropolitan Park Commission's edict went into effect Saturday against the use of tire chains and armored or metal-studded tires on automobiles driven upon any of the roads under its jurisdiction. As the Metropolitan parkways are among the most popular drives for automobilists, some of them being the principal outlets from the city and the main motor thoroughfares to other sections of the State, the prohibition of chains and armored tires will bear hard upon those automobilists who have been accustomed to use such devices to prevent skidding in wet weather. Furthermore, it is feared that the move of the Metropolitan Park Commission will be imitated by other authorities, such as the Boston Park Commission, which controls the most popular drives within the city, and the Highway Commission, which controls the State highways throughout the Commonwealth.

### SPEED-CRAZED AUTOISTS MAKE ADVERSE LAWS.

NEW HAVEN, CONN., May 4.—Local autoists are in a furore over an attempt which is soon to be made in the board of Aldermen to exclude automobiles from certain congested business streets in the center of the city. This attempt follows the instant killing of a little girl a day or so ago by an automobile carrying a party of Yale students—the fourth fatality within a space of five months, in two of which cars driven by Yale men have figured.

An energetic police campaign against speeding has resulted, traps have been set on all the principal thoroughfares, and a large number of Yale men and prominent autoists have been arrested and heavily fined in the police court. Following the most recent fatality, De Forest Hurlbud, of Chicago, a Yale senior, was fined \$100 with costs in the police court for speeding his steam car up one of the steepest hills in the city.

### BEWARE OF SPEED TRAP IN WESTFIELD, N. J.

WESTFIELD, N. J., May 5.—There are not a few citizens of this town who welcome the coming and passing of the automobile and would like to see touring through Westfield made a pleasure rather than a pain. One of these is Dr. Frederic Adrian Kinch, who in bicycling days was a very active worker for the rights of cyclists as an officer of the L. A. W. Dr. Kinch has taken upon himself to send out warning of a speed trap that has been laid and working for two Sundays past on Mountain avenue, an eighth of a mile north of the big white Presbyterian church.

### BELIEVES AGE LIMIT SHOULD BE INCREASED.

WASHINGTON, D. C., May 4.—Leroy Mark, secretary of the Automobile Club of Washington, has suggested to the District Commissioners that the age limit for operators of automobiles be raised from sixteen to eighteen years. He has pointed out that in many instances it has been proven that a sixteen-year-old boy is not capable of handling a car in the crowded streets. Mr. Mark's suggestion has been approved by many automobile owners, and it is likely the Commissioners will raise the limit, which will also be made to apply to minors operating motorcycles.

## AUTO CLUBS ARRANGING SEASON'S PROGRAM

### LONG ISLANDERS WILL ENTERTAIN ORPHANS.

NEW YORK, May 4.—Whatever may be the fate of this year's Orphans' Day at the hands of Manhattan, its originator and first promoter, the Brooklyn end of the Greater City is not to permit the time-honored celebration to go by default. The Long Island Automobile Club has already headed the subscription list with \$150 by way of starting the fund. It has also appointed the following committee to go ahead with the promotion and report back to the club at its next meeting its plans: Dr. William P. Richardson, Charles C. Cluff, Louis T. Weirs, and W. T. Wintringham. The Long Island Automobile Club did splendid work last year in seeing that the children of the Brooklyn orphanages were given their annual auto ride to Coney Island and outing at Luna Park.

The New York Motor Club, under whose auspices the first annual outing was given the orphans in 1905, having no longer an active existence, it remains for some other organization or group of individuals to see to it that the celebration is not omitted this year. The New York Automobile Trade Association might well undertake the promotion of New York's end of the observance, and in so doing might enlist the assistance of Alfred Reeves, of the A. M. C. M. A., and Harry T. Clinton, of the A. L. A. M., who would doubtless gladly, on behalf of their respective associations, lend a helping hand to this historic automobile charity. Unfortunately, S. A. Miles, general manager of the N. A. A. M., who for the past two years has practically assumed the individual responsibility and the brunt of the labor of Orphans' Day in New York, is absent in Europe.

The Orphans' Day idea originated with W. J. Morgan, who enlisted the cooperation of the then very active New York Motor Club in putting it through. This was done with so great a success that the clubs of other cities to a considerable extent followed suit until the celebration became so general that last year the American Automobile Association set the second Wednesday in June for a national Orphans' Day. The choice of Wednesday, however, did not prove universally convenient for all cities. In consequence, the clubs throughout the country chose their own dates for the most part, though adhering very generally to June. It is now probable that the A. A. A. will officially set an Orphans' Week, during which an "Orphans' Day" will be recommended to be celebrated by organizations interested in the movement.

### QUAKER CITY CLUB'S ORPHANS' DAY, JUNE 10.

PHILADELPHIA, May 3.—Wednesday, June 10, has been decided upon by the Quaker City Motor Club as the date for this year's Orphans' Day run. No objective point has as yet been selected, but as last year's run to Willow Grove was hugely successful, it is highly probable that an effort will be made to induce the Rapid Transit Company, owners of the park, to again extend its free use and that of the many attractions there to the parentless little ones. Last year the number of would-be guests far exceeded the capacity of the more than 100 cars loaned for the occasion, and the committee in charge of this year's affair, under the direction of Chairman H. Lewis, proposes to make an early start in an effort to accommodate all who may wish to go. With this object in view, appeals have already been sent to the other clubs, the branch managers and agents, and to individual owners to cooperate with the committee in making this year's Orphans' Day run worthy of the city.

### BROOKLYNITES CELEBRATE SUBWAY OPENING.

BROOKLYN, May 4.—One of the features of the recent celebration to commemorate the opening of the subway extension in Brooklyn was the running of 100 decorated cars by members of the Long Island Automobile Club. Charles Jerome Edwards acted as marshal.

### MANITOBANS RECOGNIZE NEED OF UNION.

WINNIPEG, MANITOBA, May 4.—At the annual general meeting of the Winnipeg Automobile Club, these officers were elected for 1908: Honorary president, J. C. G. Armytage; president, Russell M. MacLeod; first vice-president, D. Boyce Sprague; second vice-president, P. C. Andrews; secretary-treasurer, W. E. Wright; committee, R. M. MacLeod, E. C. Ryan, S. M. Belcher, S. C. Dunn, A. A. Andrews, W. C. Power and H. A. Ayhvin; auditors, H. A. Ayhvin and Harry Gooderham. Sixteen new members were proposed and elected, bringing the membership total to nearly 200.

It was decided to affiliate the club with the recently formed Manitoba Motor League, and to hand over to the League a sum of \$2 per head for every member in good standing, in order to make them members of the Manitoba Motor League.

The Manitoba Motor League was formed for the purpose of protecting the interests of all automobile owners in Manitoba and to act as the governing body for all races, endurance contests, etc., held in the province. The league will also arrange for the provision of maps, showing the main routes throughout Manitoba, and will erect sign posts, etc., for the benefit of automobile tourists from other parts of Canada and the American side.

The officers of the League for 1908 are as follows: Honorary president, Hon. Judge Phippen; president, W. A. Elliott; first vice-president, D. Boyce Sprague; second vice-president, Joseph Maw; third vice-president, H. Stevens; secretary, W. R. Bawlf; treasurer, L. R. Barrett; committee: H. A. Ayhvin, E. C. Ryan, F. R. Newman, R. MacLeod, D. W. McDermid, Claude Isbister, H. Rogers, G. Kerr, Dr. Power, T. B. Mitchell, Dr. Montgomery, Mayor Elliott and A. J. Young.

### EXCELLENT IDEA OF A. C. OF PHILADELPHIA.

PHILADELPHIA, May 4.—The Automobile Club of Philadelphia is responsible for an innovation which the other local clubs and organizations throughout the State will probably copy in the near future. It is the naming of an Inter-club Relations Committee, whose particular business it shall be to cooperate with similar committees named by other clubs, in forwarding objects in the interests of automobilists in general and in securing uniformity of action thereon.

In a circular issued last week to automobilists generally, the club calls attention to several traps recently located in the country roundabout, and urges everybody to exercise caution, especially when in the neighborhood of these pitfalls, some of which, the circular avers, are designed as revenue producers. Among the traps mentioned is that on the main Philadelphia-New York route, between Highland Park and New Brunswick. Complaints of the treatment meted out to the unlucky automobilists at that point, says the circular, would indicate that this particular trap was "designed for the special purpose of collecting revenue." Other traps mentioned are on the Lancaster pike, opposite the Catholic seminary at Villanova; on Argyle avenue, between Haverford avenue and Lancaster pike, in Lower Merion township; on the stretch of road between Janney station and Langhorne, in Middletown township, and on the road leading through and beyond Hulmeville. The club proposes to issue these warning bulletins from time to time, as complaints are filed.

### JOYCE REELECTED PRESIDENT MINNESOTANS.

MINNEAPOLIS, MINN., May 4.—At the annual meeting of the Minnesota State Automobile Association the following officers were elected: President, Frank M. Joyce, Minneapolis; vice-president, Reuben Warner, St. Paul; secretary and treasurer, Dr. W. H. Card, Minneapolis. The annual dues of club members were raised to \$1 per annum. The old rate was 50 cents.

C. H. Kohler, chairman of the legislative committee, presented a report in which he recommended to tax of \$10 or \$20 on every automobile in the State, the money thus raised to be devoted to the making of good roads. The association favored legislation along this line. The association adopted a State emblem, the design representing interlocked wheels with the name of the corporation inscribed on the rims thereof, together with the initials "A. A. A.," for the American Automobile Association, inscribed on the face thereof. It is proposed to add to this emblem the name of each city in which there is a club.

#### BURLINGTON CLUB BECOMES VERY ACTIVE.

BURLINGTON, VT., May 4.—One of the most enthusiastic and best attended meetings that the Burlington Automobile Club has ever held took place at the Van Ness House last Saturday evening. President Hawley was in the chair, assisted by Secretary E. A. Brodie, and a number of new members were admitted. The chair appointed a committee on by-laws, consisting of W. A. Suydam, C. L. Woodbury, and G. A. Churchill, while Capt. E. P. Woodbury, B. L. Kent, and F. L. North were constituted a committee on good roads, and A. C. Whiting, A. G. Whittmore, and J. S. Patrick were appointed a committee on legislation. Plans were made for a Decoration Day parade, and a banquet, to be held some time during the third week in May. W. A. Suydam, of the *Daily News*, was appointed corresponding secretary.

#### NEW ENGLAND AERONAUTS DINE AND TALK.

BOSTON, May 2.—The first dinner of the Aero Club of New England was held this evening at the clubhouse of the Boston City Club, and about fifty members and guests were present. Prof. A. Lawrence Rotch presided. Committees were appointed to investigate dirigible airships, and H. H. Clayton was appointed a committee to investigate the cost of placing a club balloon in commission. Charles E. Hellier spoke on the policy of the club, and advocated that it proceed along scientific rather than sporting lines, encouraging the inventors of New England who are working at the problems of aerial navigation. A. R. Shrigley, secretary of the club, outlined the new legal difficulties which will arise when the air is commonly used. Such things as eminent domain, trespass, and the like, will cause much litigation.

#### LAWRENCE, MASS., CLUB IS FLOURISHING.

LAWRENCE, MASS., May 4.—At the annual meeting of the Lawrence Automobile Club, held at the Essex House, the following officers were elected for the ensuing year: President, J. Frank James; vice-president, Walter Coulson; secretary-treasurer, Harry K. Lawrence. Dr. Charles G. Pierce, James C. Forbes, and Albert S. Lang comprise the board of directors. Among the events planned are regular weekly runs and an Orphans' Day parade. A committee consisting of J. Frank James, John O'Neill, and Charles G. Pierce was appointed to confer with the superintendent of streets relative to grade crossings. The club now has ninety members and is in a flourishing condition.

#### A BIGGER ORMOND-DAYTONA CLUBHOUSE.

DAYTONA, FLA., May 2.—At the recent annual meeting of the Florida East Coast Automobile Association, J. B. Foster was re-elected president. The other officers elected were: First vice-president, S. H. Gove; second vice-president, J. H. Allen; secretary, T. E. Fitzgerald; treasurer, F. N. Conrad; board of directors, R. M. Bond, A. Hilliard, J. B. Moore, E. F. Oates, H. B. Welch, and T. E. White. It was voted at this meeting to build an addition to the clubhouse and also erect bath-houses.

#### OHIO'S STATE BODY ACTIVELY PROGRESSIVE.

CLEVELAND, April 4.—The Ohio State Automobile Association is coming in for a great deal of praise these days, for, in addition to organizing an automobile club in Columbus and getting the Motor Vehicle bill through the legislature, a new club has been organized in Kenton. The Dayton club will also reorganize.

## THE AUTOMOBILE CALENDAR. AMERICAN.

### Shows and Meetings.

- June 25-27.....—Detroit, Third Annual Summer Meeting of Society of Automobile Engineers.
- Dec. 31-Jan. 7.....—New York City, Grand Central Palace, Ninth Annual Automobile Show, conducted by the American Motor Car Manufacturers' Association, with Exhibits by the Importers' Automobile Salon, Inc., and Motor and Accessory Manufacturers, Inc. Alfred Reeves, general manager, 29 West 42d St.
- January, 1909.....—New York City, Madison Square Garden, Ninth Annual National Show of the Association of Licensed Automobile Manufacturers. (Exact date to be announced.)
- February, 1909.....—Chicago, Coliseum and First Regiment Army, Eighth Annual National Exhibition, National Association of Automobile Manufacturers. (Exact date to be announced.)
- Race Meets, Hill Climbs, Etc.**
- May 15.....—Chicago, Algonquin Hill Climb, Chicago Motor Club.
- May 16.....—Hartford, Conn., 200-mile Endurance Run, Automobile Club of Hartford.
- May 30.....—Boston, Readville Track, Race Meet, Bay State Automobile Association.
- May 30.....—Bridgeport, Conn., Sport Hill Climb, Bridgeport Automobile Club.
- May 30.....—Wilkes-Barre, Pa., Giant's Despair Hill Climb, Automobile Club of Wilkes-Barre.
- May 30.....—San Francisco, Endurance Run under the auspices of the Automobile Dealers' Association.
- June 6.....—Worcester, Mass., Dead Horse Hill Climb, Worcester Automobile Club.
- June 24-27.....—Chicago, 1,200-mile Reliability Run, Chicago Motor Club.
- July 7-8.....—Buffalo, N. Y., National Convention of the American Automobile Association.
- July 9.....—Buffalo, N. Y., Start of the Fifth Annual A. A. A. Reliability Touring Contest.
- Sept. 5-9.....—San Francisco-Los Angeles Reliability Run, Automobile Dealers' Association of San Francisco.
- Sept. 14.....—Chicago, Annual Economy Run, Chicago Motor Club.

### FOREIGN.

#### Shows.

- May 17-31.....—Austria, Budapest Automobile Show.
- May 17-June 2.....—Moscow, Russia, International Automobile Exposition, Automobile Club of Moscow.
- December.....—Paris, Eleventh Annual Salon de l'Automobile, Grand Palais, Automobile Club of France.
- Race Meets, Hill Climbs, Etc.**
- May 7.....—Sicily, Palermo, Targa Florio Circuit, Voiturette Race, Automobile Club of Italy.
- May 11-16.....—Ireland, Irish Reliability Trials.
- May 1-31.....—Automobile Taxicab Competition, France, Automobile Club of France.
- May 10.....—Sicily, Targa Florio, Automobile Club of Italy.
- May 31.....—Russia, St. Petersburg to Moscow Race.
- June 1-18.....—Reliability Trials for Pleasure Cars, Automobile Club of Great Britain.
- June 14.....—Mount Cenlis Hill Climb, for Voiturettes.
- June 9-17.....—Touring Competition for the Prince Henry of Prussia Prize, Germany, Imperial Automobile Club.
- June 15-19.....—Scotland, Scottish Reliability Trials.
- July 6.....—Voiturette Grand Prix, Dieppe Circuit (Automobile Club of France).
- July 7.....—Grand Prix of Automobile Club of France, Dieppe Circuit.
- July 13-17.....—Ostend, Belgium, International Race Week, Automobile Club of Ostend.
- July 20-30.....—Ardennes Circuit Races and Coupe de Liedekerke, Automobile Club of Belgium.
- Aug.....—France, Coupe de la Presse, Automobile Club of France. (Exact date to be announced.)
- Aug. 29-30.....—France, Mont Ventoux Hill Climb, Vauclusien Automobile Club.
- Sept. 1-8.....—French Voiturette Contest, auspices of "L'Auto."
- Sept. 6.....—Bologne, Italy, Florio Cup Race, Automobile Club of Bologne.
- Oct. 11.....—Berlin, Germany, Gordon Bennett Balloon Race, Aeronautical Club of Berlin.

## A. L. A. M. TESTS A. C. A. DYNAMOMETER—RESULTS LATER

AS a result of the discrepancy in the showing of the cars of certain of the members of the Association of Licensed Automobile Manufacturers, when tested out on the dynamometer of the Automobile Club of America, as compared with tests of the makers themselves, an imposing delegation from the Mechanical Branch of the Licensed association took possession of the dynamometer testing plant on Tuesday last, at the invitation of the club. The morning was spent in carrying out sundry tests to learn just where the vulnerable points of the apparatus lay, while the checking tests themselves were carried out in the afternoon. It was the consensus of opinion of the visiting engineers that the slip between the drums of the dynamometer and the driving wheels of the car under test was excessive, particularly at the higher speeds, and one of the chief objects of the tests was to learn exactly what this amounted to.

A. L. Riker acted as starter, while Henry Souther was posted at the left-hand driving wheel of the car with a revolution counter, and John G. Utz, similarly equipped, took a position at the right-hand wheel. Hiram Maxim kept watch of the speed indicator and Russell Huff did similar duty at the traction indicator. A Thomas-Detroit 40-horsepower runabout was run on the drums and half-minute tests carried out at speeds of 20, 30, 35, 40, 50 and 60 miles an hour. On the first test the rear wheel turns showed a discrepancy of half a turn, the right giving 92.5 and the left 93—a difference so small as to be accounted for by

errors in reading. Two of the spark plugs cracked and none of the A. L. A. M. standard plugs being available, the Thomas gave way to a Packard touring car which was put through eight different half-minute tests at from 20 to 60 miles an hour. It was succeeded by a Locomobile 45-horsepower roadster, of which Mr. Riker took the wheel, turning over the job of timing to Coker F. Clarkson, while the latter ceded his duties as checker to H. T. Clinton. The differences in the readings at the rear wheels were much greater at the higher speeds, ranging as high as five to ten revolutions apart.

After the Locomobile had been put through its paces at the higher speeds, at which it was found much easier to take accurate readings, as the tapes continually fluctuated, more or less, at the lower rates of travel, and the necessary data carefully noted for reference, the visiting engineers adjourned to one of the committee rooms on the lower floors of the clubhouse to figure out the results of the data already compiled. These calculations will be checked with the figures shown by the tests of the makers on the same cars, just prior to sending them to the club dynamometer for testing. Should any great discrepancy appear, it was the intention of the visiting delegation to undertake further tests to check up the results. The concrete results of the visit will take the form of a report to be made public within a few days, and the contents of the document will be looked forward to with considerable interest by the trade.

### PHOTO TOLD TRUTH; CAPTION ERRONEOUS.

An erroneous caption under one of the illustrations on page 596 in THE AUTOMOBILE's story of the Briarcliff race stated that a change of tires was taking place on the Panhard car, which really stopped at the Continental station for a supply of gasoline and water. Anyone who gave this picture a close scrutiny would have noted the fact that nothing was being done to the tires, but gasoline and water were being taken on, for it is a fact that this particular Panhard, fitted with Continental tires, went through the race without any change of tires.

### P-S SKIMABOUT OUTPUT IS INCREASED.

It was at first intended by the Palmer & Singer Manufacturing Company, of New York City, to make only 25 cars of its new Skimabout type, but the first car placed on exhibition in the company's salesrooms, 1620-1624 Broadway, has resulted in so many immediate sales that the number will be greatly increased. The Skimabout has 28-30 horsepower and is of short wheelbase, which, its makers state, particularly adapts it to city use, it being turnable in the narrowest streets and well fitted to take advantage of openings in traffic. Its power is ample for country touring and it is capable of high speed. Its price is \$1,950.

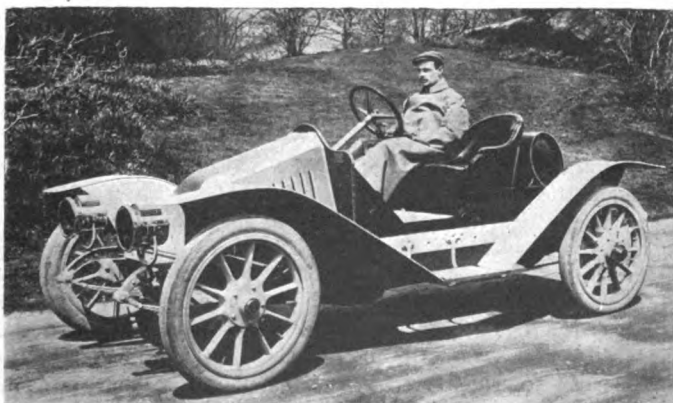

Chas. A. Singer, Jr., in the Palmer-Singer Skimabout.

### MOST UNUSUAL PHOTO OF THE BRIARCLIFF.

Through an oversight, the excellent action picture of Isotta No. 11 in the Briarcliff race, published in the April 30 issue, page 603, was not marked "Copyright, 1908, Pictorial News Company." The picture was an unusual one, and the Pictorial News Company photographer has reason to be proud of his achievement. N. W. Penfield is the head of this company, the offices of which are located at 138 West Forty-second street, New York City.

### MORA MAKES ANOTHER RELIABILITY RUN.

BUFFALO, May 4.—After having had the power plant of a six-cylinder Mora demonstrator, taken from the stock of the Buffalo representatives of the company, officially sealed by Secretary Dai H. Lewis, of the Automobile Club of Buffalo, H. B. Odell started at 11:20 A.M., April 23, for a 1,000-mile reliability run under sealed bonnet conditions. The test was made on the streets of Buffalo and on the roads, 30 to 35 miles outside the city. The run was completed in 47 1/2 hours actual running time, or an average of 21 miles an hour, making allowances for tire repairs. Several press representatives and members of the automobile club acted as observers.

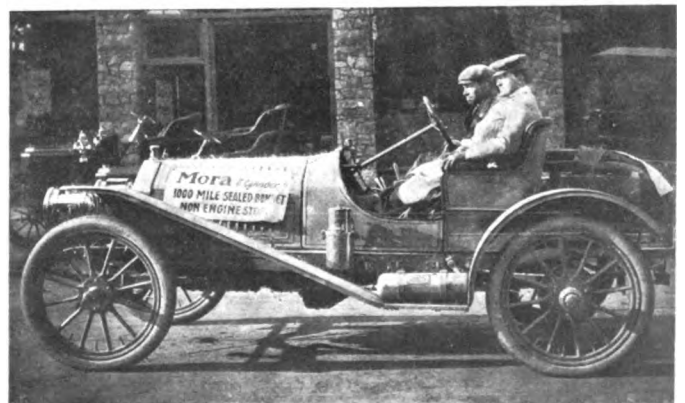

Sealed-bonnet Mora Starting on 1,000-mile Run.



## METZGER OUT: BENSON CADILLAC SALES MANAGER

**D**ETROIT, May 4.—Ernest R. Benson, who on April 30 succeeded William E. Metzger as sales manager of the Cadillac Motor Car Company, is, through his former connections, well known to the trade. He was with the Pope Manufacturing Company for twelve years and rose to be secretary of one of the companies connected with them. He was with A. G. Spalding for seven years.

In 1896 Mr. Benson went with the Hartford Rubber Works Company, opening their Boston branch, and soon had charge of the New England territory for that company. He remained with them for eleven years and finally rose to secretary for the company having charge of the commercial end.

His connection with the Cadillac Motor Car Company began December 1, 1907. The Cadillac Company has, during the past few months, made a great many changes in its method of selling, also a large number of changes in their sales organization, and these changes have already accomplished much for the company.

Vigorous methods have been used to post dealers on the selling points and advantages of Cadillac cars. The company reports that this work is showing most gratifying results.

William E. Metzger has resigned the sales management of the Cadillac Motor Car Company, of Detroit. In a brief telegram to *THE AUTOMOBILE*, Mr. Metzger says that his resignation terminated his connection with the company.

William E. Metzger is one of the pioneers, ablest and most prominent men in the automobile industry. He is second vice-president of the National Association of Automobile Manufac-

turers and a member of the executive committee of the Licensed Association of Automobile Manufacturers.

Like many of the successful men in the motor car industry, Mr. Metzger had the advantage of a preliminary training in the bicycle business. In those days he was also a great salesman, and represented in Detroit at different times several of the leading makes of bicycles.

With the coming of the automobile, Mr. Metzger was early in the new field as Detroit agent for the Columbia and the Winton. In fact, he has always maintained his retail establishment. In 1902 he interested Messrs. Percy, Black, White and Leland in the formation of the Cadillac Company. It had for its foundation the Detroit Automobile Company, which built cars for Henry Ford and was bought by the new company.

Up to two years ago Leland and Faulkner built the engines for the Cadillac Automobile Company as a separate concern. Then the latter company was reorganized under the name of the Cadillac Motor Car Company, the firm of Leland and Faulkner being taken into the new combination.

Mr. Metzger is known as the most experienced and is rated by many as the best sales manager in the automobile trade. His connection with the Cadillac companies has always been in this capacity. Under his sales management Cadillac cars attained an enviable popular and numerical vogue.

Mr. Metzger has not announced as yet his plans for the future. Besides his big retail business in Detroit, he is reported to be financially interested in several motor car making concerns in that city. An announcement is expected.

### MICHELIN OPPOSES PRICE CUT FOR CLUB.

Edouard Michelin, of Michelin & Co., the big French tire-making firm, has resigned the presidency of the Automobile Club d'Auvergne, as a protest against the club's alliance with Association Générale Automobile with a view to securing for its members tires at cut prices. In view of a threatened similar movement in this country headed by a club which has loudly protested its policy of fostering the industry, M. Michelin's letter is interesting and very much to the point. It follows:

Grasse, France, 25th Feb.

The affiliation of the Automobile Club d'Auvergne with the Association Générale Automobile, which offers as a special inducement to its members the fact that they will get a rebate on all automobile supplies, in particular tires, is of a nature to cause great prejudice to automobile agents.

I consider this an unfair proceeding against the agents, who are the indispensable contributors to automobilism. It would, indeed, if the public's common sense and justice did not prevail, rob these commercial men of a profit to which they are legitimately entitled, and which is not exaggerated. I, therefore, do not wish to form part of it, not even indirectly.

I do not know what other rubber firms of Clermont-Ferrand intend doing, but, as far as I am concerned, I beg to confirm my resignation, which Mr. Borel handed you on my behalf, when you voted for this new arrangement.

I deeply regret to leave the Automobile Club d'Auvergne, and I can only leave in order not to follow the new track in which it moves.

EDOUARD MICHELIN.

### DEMOCRATIC POLITICIANS TO TOUR TO DENVER.

-CHICAGO, May 4.—Roger C. Sullivan, Democratic committeeman for Illinois to the convention at Denver next July, has instituted a brand new departure in the political use of the automobile by planning a run to the Democratic convention city from here. The party will consist of a number of congressmen and prominent Democratic politicians, who will utilize four Studebaker cars, while a Studebaker truck will follow the train as baggage carrier. The start will be made June 27.

### OPENING OF AJAX-GRIEB NEW PLANT.

TRENTON, N. J., May 5.—The opening of the new additions to the tire factory of the Ajax-Grieb Rubber Company will be celebrated next Monday with no little ceremony. Governor Fort has accepted an invitation to turn on the steam. Many prominent automobilists and tradesmen are expected to take part in the inaugural celebration. The New York party will leave on a special train over the Pennsylvania road in charge of Horace DeLisser, president of the company, while William Grieb will attend to the delegation that leaves on the special from Broad street station, Philadelphia, at 1:40 P. M. The New York party will leave Twenty-third street at 11:55 P. M., and from Cortlandt and Desbrosses streets at 1 P. M. The special trains carrying the delegations will run on the siding alongside the factory, and after the plant has been examined and the visitors shown how tires are made, from the first work on the pure rubber to the finished article, there will be a dinner.

The new buildings are a notable addition to the industrial development of Trenton, and are the best possible proof of the success that Ajax tires have attained during the past few years. The new buildings of brick and cement will add something like 55,000 square feet to the present capacity.

### FORD INTERESTS ASK SECURITY FOR COSTS.

An interesting development in the so-called Selden Patent litigation, consisting of the various actions of the Electric Vehicle Company, of Hartford, Conn., now in the hands of receivers, against the Ford Motor Company and others, which is pending in the United States Circuit Court for the Southern District of New York, is brought to light in a motion which will be made by R. A. Parker, of counsel to the Ford interests, through the New York attorneys, Cardozo & Nathan, to have the complainants deposit security for costs, and that the proceedings may be stayed, pending such deposit. This motion is set for hearing Friday, May 8.

## BRIEF ITEMS OF NEWS AND TRADE MISCELLANY

J. Burton Lippincott, the Philadelphia publisher, has become a convert to the six-cylinder idea, his latest acquisition being a six-cylinder Winton limousine.

Harry Knox, of the Atlas Motor Car Company, Springfield, Mass., has just secured an additional order from the New York Transportation Company for 300 more of the two-cycle taxicabs equipped with the special Atlas motor.

The Reo Motor Car Company, Lansing, Mich., has just declared a dividend of 20 per cent. to its stockholders, and, according to the officers of the company, it has had a very prosperous year, while the prospects for the present season are better than ever.

In the description of the Acme igniter, made by the Pittsfield Spark Coil Company, Dalton, Mass., which recently appeared in *THE AUTOMOBILE*, it was stated that the igniter was designed to be used in connection with a vibrating coil. This should have read "non-vibrating," as the igniter is of the synchronous type embodying a high-tension distributor.

Among the American concerns who are already making plans to enter cars in the Vanderbilt race, is the Acme Motor Car Company, Reading, Pa., H. M. Sternberg, the president of the company, being authority for the statement that negotiations have already been undertaken, looking to the engagement of Louis Strang to pilot the Acme entry.

Colonel Sprague, of canopy top and umbrella fame, who has made the town of Norwalk, Ohio, one of the best known places of its size on the map, reports that the Sprague Umbrella Company is besieged with customers, the plant being run to its full capacity every minute of the time, which does not look very much like hard times.

Application has been made by the receivers of the Pope Manufacturing Company, Albert L. Pope and George A. Yule, for permission to continue the business for four months from April 28. They will also ask the court to pass on their semi-annual report, showing receipts of \$900,743, disbursements of \$822,952, and a balance of \$77,791. The receivers report that business is satisfactory and that there is a substantial demand for new cars.

The verdict against the Matheson Motor Car Company, Wilkes-Barre, Pa., in favor of Fred S. Dickinson, of New York, granting him \$16,000 of the stock of that company, which he claimed was due him for services rendered by him in behalf of Charles R. Greuter in securing the latter his position with the Matheson Company, was set aside by Judge Archibald on April 30, sitting in the United States Circuit Court for the District of Pennsylvania, at Scranton.

February and March, 1908, were the best months that the Firestone Tire & Rubber Company, Akron, O., has had in its manufacturing career, while April has eclipsed all sales records. The central section of the new Firestone plant has just been completed, and the machinery for the manufacture of both solid and pneumatic tires has been installed. It replaces the one story structure which was the original factory, and is the fourth and largest addition of its kind to a factory devoted to the

manufacture of rubber tires, that has been made in this country in the last four years.

To those who know the road conditions, the new record from San Francisco to Los Angeles, Cal., made by a 30-horsepower White steamer, is considered a remarkable performance. The trip is 478 miles and was made in 17 hours and 17 minutes, 56 minutes better than the previous record, which has stood for over a year. Since autos were introduced on the Pacific slope the road record between these two cities has engaged the activities of ambitious California drivers, as the holding of the record gives a big prestige to the successful car. The road traveled is of dangerous character and presents many obstacles to rapid travel.

One of the most interesting entries in the A. A. A. reliability tour this July, is a regular stock model 15, Elmore touring car, which was received by the San Francisco agents of the Elmore company, March 3, 1906. This car is the holder of a big string of records, and it is the purpose of its makers to have it continue its triumphant way. It has been driven in every race meet, road race, hill climb and endurance run in southern California, since the time it was sent to that State. In every endurance run, it has made a perfect score,



On the Briarcliff Course.

How the National Sales Corporation utilized an advantageous opportunity to show the public what they sell.

and in the 50-mile motor derby at Los Angeles, May 12, 1907, it won the cup from a number of competitors. Its next victory was on the occasion of the 30-mile Lakeside motor derby race, in which it made the 30 miles with full load in regular touring order, in 39 minutes. To date it has run 16,000 miles without being taken down, or having had its bearings touched. It will be run to Cleveland this summer and after finishing the reliability tour, will be returned to Los Angeles in time to take part in the Mount Baldy race.

### RECENT TRADE REMOVALS.

The Isotta Import Company moved from its old quarters at 12 West Thirty-third street, to the Palmer & Singer building, at 1620 Broadway, C. M. Hamilton, manager of the company, having found a location on "automobile row" a necessity.

### NEW AGENCIES ESTABLISHED.

The firm of Stade & Farrow, which was recently organized to handle the Grout car in Boston, has established headquarters at 94 Massachusetts avenue.

Benjamin Gerdelman has just been appointed the St. Louis representative of the

Jones Speedometer Company and will look after the interests of this firm in St. Louis and vicinity. Mr. Gerdelman will still retain his agency connection with the With-erbee Igniter Company, with whom he has been associated for a number of years.

Frederick Phillips, Jacksonville, Fla., has taken on the Franklin line for that city and vicinity and will handle that line of cars exclusively. The automobile business is a new venture for Mr. Phillips, who is a well-known civil engineer, formerly of Utica, N. Y., but is now engaged in building a concrete retaining wall along the St. John river in Florida, which will reclaim land estimated to be worth \$240,000. He will build a fine garage and salesroom and give the business much of his personal attention.

### PERSONAL TRADE MENTION.

C. M. Strieby, formerly with the Ford Motor Car Company, and president of the Ford Motor Club, is now connected with the sales forces of the L. J. B. Company, Philadelphia agents for the Thomas line.

B. C. Hamilton, formerly vice-president of the Hamilton Automobile Company, Chicago, has just joined the agency forces of the local Studebaker representatives, and will act as manager of the sales department in that city.

E. M. Beauchamp has just been added to the sales department of the E. R. Thomas Detroit Company, and will act as assistant to Manager Whipple. Mr. Whipple was formerly connected with the Locomobile Company.

John S. Johnson, formerly champion cyclist and skater, who was lately assistant to Manager Earl Kiser, of the Pittsburg branch of the Winton Motor Carriage Company, has been appointed Winton sales representative for Minnesota, and will take up his duties in that field at once.

Edward B. Busby, formerly with the Midvale Steel Company, has recently become associated with the selling department of the Electric Welding Products Company, Cleveland, O., formerly the Cleveland Cap Screw Company. Mr. Busby has quite a wide acquaintance among automobile, engine and machinery manufacturers.

B. J. Dollins, for the past two years associated with the Continental Tire Company, has just severed his connection with that concern to join the selling forces of the Pennsylvania Tire Company. He will act as traveling representative in the western territory. According to W. D. Rockwell, sales manager of the company, a western branch house is shortly to be established in Denver.

George Salzman, for six years assistant superintendent of the E. R. Thomas Motor Company's factory at Buffalo, has just resigned from that post to become treasurer and general manager of the American Motor Car Company, of Atlanta, Ga., sales agents for the Thomas Flyer. Mr. Salzman's driving won him many friends on the occasion of the Savannah race, and the Atlanta company placed a \$65,000 order on condition that Mr. Salzman was to be released to take the management of their company. Should the Vanderbilt race take place on the Savannah course, Salzman will have the wheel of a Thomas.

**INDEX TO ADVERTISERS**

Abrams-Mason Co. ....	91	Jackson Automobile Co. ....	60	Picrome Hide Co. ....	58
Acetylene Gas Illuminating Co. ....	56	Jeffery & Co., Thos. B. ....	93	Pierce Engine Co. ....	61
Acme Motor Car Co. ....	60	Jeffery-DeWitt Co. ....	55	Pioneer Brass Works. ....	58
Adams Co. ....	60	Jencick Motor Mfg. Co. ....	71	Pirelli & Co. ....	62
Aerocar Motor Co. ....	60	Johnson Sporting Goods Co., I. ....	62	Pittsfield Spark Coil Co. ....	71
Ajax-Grieb Rubber Co. ....	62	Jones Speedometer ....	72	Prest-O-Lite Co. ....	101
Almy Water Tube Boiler Co. ....	55	Joyce Cridland Co. ....	82	Progressive Mfg. Co. ....	75
Allen Auto Specialty Co. ....	67	K. W. Ignition Co. ....	97	Quinby Co., J. M. ....	59
American Ball Bearing Co. ....	73	King Mfg. Works, A. ....	97	Raimes & Co. ....	55
Am. Brass & Alum. Works. ....	58	Keystone Lubricating Co. ....	68	Raimes & Co. ....	55
American Bronze Co. ....	76	Kellom & Co., Chas. F. ....	65	Rajah Auto Supply Co. ....	59
American Distributing Co. ....	83	Kimball Tire Case Co. ....	70	Raimes & Co. ....	55
Amer. Motor Car Sales Co. ....	103	King Top Mfg. Co. ....	59	Randall-Faichney Co. ....	73
American Motor Truck Co. ....	77	Kinsey Mfg. Co. ....	58	Reeves Pulley Co. ....	53
Anderson Forge & Machine Co. ....	58	Kissell Motor Car Co. ....	73	Regent Tire Co. ....	80
Apperson Bros. Automobile Co. ....	87	Konigsow, Otto ....	56	Remy Electric Co. ....	56
Apppliance Mfg. Co. ....	63	Lavalette & Co. ....	58	Renault Freres ....	Cover
Ashtabula Bow Socket Co. ....	59	Lavigne Mfg. Co. ....	55	Republic Rubber Co. ....	100
Ashton Valve Co. ....	56	Lear Automobile Co., Oscar. ....	60	Rex Wrench Co. ....	75
Atlas Motor Car Co. ....	60	Leather Tire Goods Co. ....	107	Richardson Engineering Co. ....	69
Audel & Co. ....	68	Limousine Carriage Mfg. Co. ....	59	Robert Instrument Co. ....	55
Aurora Motor Works. ....	60	Lipman Mfg. Co. ....	55	Royal Equipment Co. ....	56-83
Austin Automobile Co. ....	98	Lobe Pump Co. ....	56	Rushmore Dynamo Works. ....	105
Auto Car Equipment Co. ....	87	Locke & Co. ....	89	Salsbury Wheel Mfg. Co. ....	55
Auto Pump Co. ....	61	Lockwood Bros. ....	58	Samson Leather Tire Co. ....	65
Auto Time Saver Co. ....	62	Locomobile Co. ....	60	Sanford Mfg. Co., F. C. ....	58
Autocar Co. ....	92	Logan Construction Co. ....	60	Schacht Mfg. Co. ....	96
Automobile Blue Book. ....	64	Long Arm System Co. ....	75	Selden Motor Vehicle Co. ....	68
Automobile Supply Co. ....	56	Long Mfg. Co. ....	82	Shaler Co., C. A. ....	Cover
Automobile Utilities Co. ....	62	Macbeth-Evans Glass Co. ....	91	Shawver Co. ....	55
Auto-Shine Co. ....	55	McCord & Co. ....	63	Smith Co., A. O. ....	83
Avery Portable Lighting Co. ....	71	Manhattan Storage Co. ....	55	Smith Mfg. Co., R. H. ....	68
Babcock Electric Carriage Co. ....	93	Marvel Mfg. Co. ....	86	Spacke Machine Co. ....	54
Bailey & Co., C. J. ....	50	Masury & Son, John W. ....	89	Spare Motor Wheel of Am. ....	90
Baker Motor Vehicle Co. ....	60	Matheson Motor Car Co. ....	95	Speed Changing Pulley Co. ....	77
Baldwin Chain & Mfg. Co. ....	56	Maxwell-Briscoe Motor Co. ....	108	Speedwell Motor Car Co. ....	61
Bartholomew Co. ....	83	Mayo Radiator Co. ....	56	Spicer Universal Joint Mfg. Co. ....	53
Banker Bros. Co. ....	77	Mechanical & Electrical Mfg. Co. ....	65	Spittdorf, C. F. ....	72
Barnett Drop Forging Co. ....	54	Merchant & Evans Co. ....	85	Sprague Umbrella Co. ....	73
Beaver Mfg. Co. ....	91	Merritt & Co. ....	63	Springfield Portable House Co. ....	90
Behen-Faught Motor Car Equip. Co. ....	56	Mezger, C. A. ....	58	Standard Automatic Lub. Co. ....	56
Bellfuss Motor Co. ....	76	Michellin Tire Co. ....	62	Standard Co. ....	90
Beloit Supply Co. ....	61	Midland Motor Car Co. ....	65	Standard Connecting Rod Co. ....	66
Black Mfg. Co. ....	75	Miller Bros. ....	59	Standard Welding Co. ....	72
Blasler Mfg. Co., M. E. ....	59	Miller, Chas. E. ....	84	Star Speedometer Co. ....	88
Bosch Magneto Co. ....	95	Miller & Starr. ....	56	Steam Carriage Boiler Co. ....	55
Boston Auto Gage Co. ....	55	Mitchell Motor Car Co. ....	60	Stearns Co., F. B. ....	61
Bowser & Co., S. F. ....	86	Model Automobile Co. ....	60	Stevens-Duryea Co. ....	100
Boyle & Co., John. ....	102	Moline Automobile Co. ....	61	Studebaker Automobile Co. ....	103
Brennan Motor Mfg. Co. ....	86	Monitor Distributing Co. ....	62	Success Auto Buggy Co. ....	61
Brown Co. ....	72	Moon Motor Car Co. ....	85	Supplementary Spiral Spring. ....	70
Brownell Motor Co., F. A. ....	55	Mora Motor Car Co. ....	Cover	Swinehart Clincher Tire Co. ....	75
Buckeye Jack Mfg. Co. ....	65	Morgan & Wright. ....	62	Syracuse Aluminum & Bronze Co. ....	89
Buckeye Mfg. Co. ....	60	Mosler & Co., A. R. ....	61	Thomas Spring Works. ....	80
Buffalo Carbureter Co. ....	83	Moss Photo Engraving Co. ....	104	Thomas Motor Co., E. R. ....	77
Buob & Scheu. ....	59	Motor Car Co. ....	82	Thompson Sons Co., J. P. ....	62
Burlington Basket Co. ....	65	Motor Car Specialty Co. ....	80	Timken Roller Bearing Axle Co. ....	99
Byrne-Kingston Co. ....	89	Motz Clincher Tire & Rub. Co. ....	62	Tincher Motor Car Co. ....	87
Cadillac Motor Car Co. ....	60	Mound Tool & Scraper Co. ....	76	Torbensen Motor Car Co. ....	84
Cameron Car Co. ....	60	Mutty Co., L. J. ....	59	Tray Plate Battery Co. ....	76
Canton Drop Forge & Mfg. Co. ....	58	National Auto Accessories Co. ....	55	Trebert Gas Engine Co. ....	61
Capitol Auto Co. ....	59	National Motor Vehicle Co. ....	93	Trojan-Hydro Pneumatic Wheel Co. ....	84
Carr, F. S. ....	59	Neustadt Auto & Supply Co. ....	92	Tucker, C. F. ....	55
Champion Co., A. ....	78	Never-Miss Spark Plug Co. ....	56	Uncas Specialty Co. ....	66
Chandlee & Chandlee. ....	64	New England Motor Co. ....	76	U. S. Fastener Co. ....	73
Chase & Co., L. C. ....	88	New York Gear Works. ....	59	Veeder Mfg. Co. ....	94
Chase-Shawmut Co. ....	64	N. Y. Sporting Goods Co. ....	59	Vehicle Specialty Corp. ....	66
Chicago & Alton Ry. ....	67	N. Y. & N. J. Lubricant Co. ....	82	Warner Instrument Co. ....	102
Clark, E. S. ....	55	Nichols & Co., D. P. ....	69	Watt-Detroit Carbureter Co. ....	86
Cleanola Co. ....	65	Nordyke & Marmon Co. ....	60	Wayne Automobile Co. ....	61
Cleveland Spark Plug Co. ....	83	Northway Motor & Mfg. Co. ....	56	Weed Chain Tire Grip Co. ....	69
Cleveland-Canton Spring Co. ....	77	Nuttall Co., R. D. ....	58	Welch Motor Car Co. ....	90
Colgan Co., J. W. ....	56	Ofeldt & Sons. ....	62	Western Motor Co. ....	77
Columbia Lubricants Co. ....	76	Olds Motor Works. ....	61	Weston Elec. Instrument Co. ....	85
Comptoir d'Innovations pour Automobiles. ....	91	Oliver Mfg. Co. ....	70	Wheeler & Schebler. ....	110
Continental Caoutchouc Co. ....	62	Owen & Co., R. M. ....	61	White Co., The. ....	109
Continental Motor Mfg. Co. ....	71	Pacific Tucking & Mfg. Co. ....	55	White & Bagley Co. ....	Cover
Conn. Tel. & Elec. Co. ....	72	Packard Electric Co. ....	63	Whitney Mfg. Co. ....	58
Corbin Motor Vehicle Corp. ....	90	Packard Motor Car Co. ....	112	Winton Motor Carriage Co. ....	Cover
Cornish-Friedburg Motor Car. ....	60	Palmer & Singer Mfg. Co. ....	61	Wisconsin Tire Protector Co. ....	82
Correspondence School of Motor Car Fractice. ....	56	Parish & Bingham. ....	58	Witherbee Igniter Co. ....	72
Cotta, Chas. ....	61	Parker, Stearns & Co. ....	75	Wyman & Gordon Co. ....	54
Cowles & Co., C. ....	55	Peerless Motor Car Co. ....	Cover	York Motor Car Co. ....	87
Crown Soap Co. ....	68	Peugeot Freres ....	56	Zimmerman Mfg. Co. ....	84
Cullman Wheel Co. ....	53	Pfanstiehl Elec. Laboratory. ....	56		
De Luxe Motor Car Co. ....	60				
Diamond Chain & Mfg. Co. ....	34				
Diamond Rubber Co. ....	38				
Dien, Ch. ....	92				
Dietz Co., R. E. ....	67				
Dixon Crucible Co., Joseph. ....	68				
Dorris Motor Car Co. ....	34				
Duff Mfg. Co. ....	55				
Duplex Coil Co. ....	56				
Duplex Co. ....	68				
Earl Motor Car Co. ....	60				
Echo Mfg. Co. ....	61				
Eclipse Machine Co. ....	58				
Eco Mfg. Co. ....	61				
Edmunds & Jones Mfg. Co. ....	56				
Eldredge Electric Mfg. Co. ....	63				
Elite Mfg. Co. ....	80				
Ellsworth, J. M. ....	106				
Elmore Mfg. Co. ....	101				
Empire Automobile Tire Co. ....	84				
Empire State Tire Co. ....	62				
Excelsior Supply Co. ....	70				
Fairmount Engineering Wks. ....	60				
Fedders Mfg. Works. ....	77				
Firestone Tire & Rubber Co. ....	67				
Fisk Rubber Co. ....	96				
Flandrau & Co. ....	50				
Flentje, Ernst. ....	75				
Forest City Motor Car Co. ....	96				
Franklin Mfg. Co., H. H. ....	111				
French Mfg. Co. ....	65				
Fry, T. C. & W. L. ....	58				
G & J Tire Co. ....	70				
Garford Motor Car Co. ....	93				
Gearless Transmission Co. ....	85				
Geszler Bros. ....	55				
Gemmer Mfg. Co. ....	72				
General Accumulator and Battery Co. ....	66				
Gibney & Bros., Jas. L. ....	56				
Goldberg Motor Car Devices Mfg. Co. ....	57				
Gordon Automobile Supply Co. ....	73				
Graves & Congdon Co. ....	82				
Groat Bros. Auto Co. ....	60				
Ham Mfg. Co., C. T. ....	82				
Hans, Edmund E. ....	76				
Hardy Co., The R. E. ....	62				
Harris, Chas. J. ....	83				
Harris Oil Co., A. W. ....	72				
Hartford Suspension Co. ....	56				
Hatcher Auto Parts Co. ....	75				
Haynes Automobile Co. ....	85				
Healy Leather Tire Co. ....	62				
Hedgeland Mfg. Co. ....	97				
Heinze Electric Co. ....	67				
Heitger Carburetor Co. ....	56				
Hercules Electric Co. ....	69				
Herz & Co. ....	63				
Hess-Bright Co. ....	58				
Hicks Speed Indicator Co. ....	77				
Hill, Geo. Q. ....	55				
Hoffecker Co. ....	62				
Hoffman, Geo. W. ....	55				
Holley Bros. Co. ....	63				
Holsman Automobile Co. ....	69				
Holt & Beebee. ....	82				
Hotel Cumberland. ....	81				
Hotel Douglas Manor Inn. ....	81				
Hotel Lafayette. ....	81				
Hotel Monmouth Beach. ....	81				
Hotel Ponchartrain. ....	81				
Hotel Tower. ....	81				
Howard Motor Works. ....	60				
Hoyt Electrical Ins. Co. ....	92				
Hub Lubricator Co. ....	72				
Huff, Jr., E. ....	76				
Hume Carriage Co. ....	59				
Imperial Motor Car Co. ....	60				
Indestructible Steel Wheel Co. ....	58				

NON-SKID

RUBBER TREAD

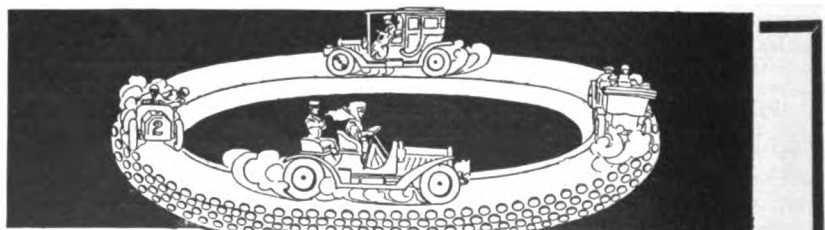

**Bailey's**  
**"Wont-Slip" Tread Tires**  
 For Automobiles, Motor Cycles  
 and Bicycles

On sale by dealers everywhere

**SKIDDING** that one terrifying moment when if your car had been equipped with  
**BAILEY'S "WONT-SLIP" TIRES**  
 the accident would not have occurred. Moral "DO IT NOW" and you will avoid such accidents. You see them everywhere. Ask the rider, he knows. There is no metal in the Bailey Tread to heat the tire, pull loose from the rubber or tear the road bed. Bailey Tires are not excluded from the Parks or Drives. The rubber studs of the Bailey Tread are the true principle that give perfect traction and prevent skidding. They are to the automobile what the rudder is to the ship. Write us for descriptive booklet.

N. B.—The extra cost of the Bailey Tires on the list more than smooth of same make is 2-2 and 3 in., \$1.50 each; 3 1/2-2 in., \$2 each; 4 in., \$2.50 each; 4 1/2-2 in., \$3 each; 5 in., \$3.75 each.

C. J. BAILEY & CO., Patentees, 22 BOYLSTON STREET, BOSTON

# THE AUTOMOBILE

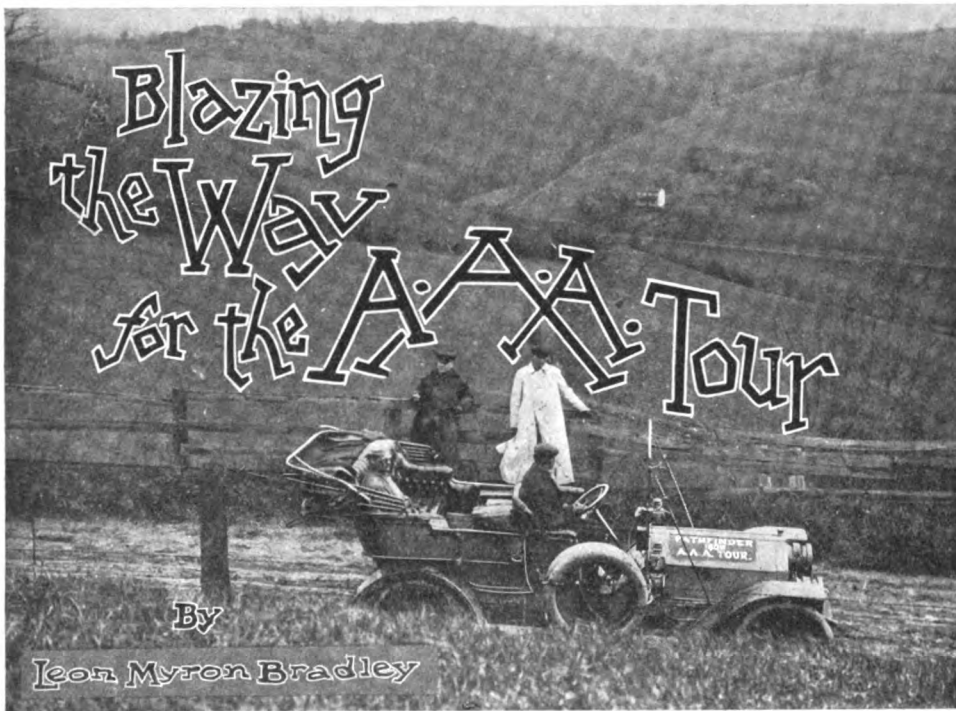

The Pathfinder left Buffalo, Friday, May 1, carrying Dai H. Lewis, secretary of the A. A. A. Touring Board; Leon Myron Bradley of New York; N. Lazarnick, official photographer, and Ray McNamara, driver of the car.

The run from Buffalo to Erie was through seven inches of snow and mud and a stinging wind was sweeping in from Lake Erie. The trip will take the tourist through fifty miles of the great vineyards and wine cellars of Western New York State. The first bad stretch of road was struck while going through the Indian Reservation outside of Buffalo. For twelve miles the roads were in terrible condition. Both rear chains were thrown off. The highways in dry weather should make excellent touring, and it will be through a flat, rolling country with sandy and clay roads in spots to the Hotel Rider, Cambridge Springs. The only sunshine which the Pathfinder saw in the first eight

**T**O the lover of Nature and he who delights in gazing at towering mountains and upon low sweeping valleys, watered by beautiful rivers and along whose banks live the thrifty Pennsylvania "Dutch" farmers, the "1908 American Automobile Association Reliability Touring Contest" for the Glidden and Hower trophies will eclipse any preceding tour in grandeur, magnificence, and exhilaration.

While it is true that last year's route took the tourists through a section of Western Pennsylvania, the route being laid out by the big six-cylinder Premier Pathfinder is far more pleasurable than that of 1907. The route as laid out for the first five days by Secretary Dai H. Lewis, of the A. A. A. Touring Board, is as follows:

- First day—Buffalo to Cambridge Springs
- Second day—Cambridge Springs to Pittsburg
- Third day—Pittsburg to Bedford Springs
- Fourth day—Bedford Springs to Harrisburg
- Fifth day—Harrisburg via Philadelphia to Millford, Pa.

Practically one-quarter of the tour has been laid out, as two thousand miles will be covered by the Gliddenites on the "Leap Year Tour."

No one but those on the Premier Pathfinder can realize what the car and the passengers have been through, unless it is those who have participated in the New York-Paris race. Time and again the car has plunged through mud, slush, and snow, many times sinking to the running board; at other times the axles have been buried in soft, clayish mud. With the exception of the Lackawanna steel works outside of Buffalo and a one-hundred mile run along Lake Erie, the trip from Buffalo to Cambridge Springs has little interest.

days was while at luncheon at the Hotel Rider. When the car was on the way, a snowstorm, which developed into a blizzard, continued during the afternoon, as far as Mercer, Pennsylvania. The thermometer registered only thirty degrees above zero. The glass front had to be lowered so that the driver could see the nature of the road ahead of him.

The worst roads of the distance already covered were encountered between Mercer and Pittsburg. From Harmony to the plank road, fourteen miles out of Pittsburg, about six miles an hour was averaged. The first cars which the Pathfinder saw between Buffalo and Pittsburg were met on the plank road, but none were seen on the country roads between Buffalo and Carlisle (famous for the Indian school) except a White, a Stanley, and a Pullman, which carried a delegation from the Harrisburg Motor Club, who came out to Carlisle to meet the Pathfinder and pilot them into the city. At the end of the plank road in Pittsburg, the Premier Pathfinder was met by E. L. Seeley, Pittsburg agent for the Premier car. The entrance of the Pathfinder into Pittsburg was a continual ovation for the mud-besmeared car.

Going from Pittsburg to Johnstown, the coal belt of Western Pennsylvania is traversed. At Export and Salemville, the coal and coke regions of H. C. Frick are passed. Here the burning coke ovens with their flames leaping scores of feet into the air can be witnessed by the tourists.

This year's run from Pittsburg west will take the tourists into Johnstown by the way of Alexandria, Blairsville, and Cramer. Eight miles west of Johnstown, the Cramer pike is struck, being the first stretch of macadam road which was seen between there and Buffalo. The road is along the Conemaugh





Encountering a May Snowstorm at Mercer, Pa.



"The Sheep Upon a Thousand Hills" Preceding Us.

river and through Laurel Hill Gap and Pack Saddle Gorge. It was down this river and through the gap and gorge that three thousand victims of the Johnstown flood were swept to eternity. The scenery through this territory is one of grandeur and admiration. It is in this section that the most picturesque route of the Pennsylvania railroad is situated. The famous stone bridge in Johnstown, which caused the great flood, will be passed

by the Gliddenites. It was there that the wreckage piled up and caused the water to back up into the city. The road goes by the Cambria Steel Works, the largest steel concern in the world, which employs twenty-two thousand hands. Johnstown is the pioneer town in the iron industry, its first plant being operated in 1560.



Secretary Lewis Deliberating.

The Johnstown Automobile Club is instrumental in having the tour pass through that

section of the country. Their representative told Mr. Lewis that they would do all in their power to have the roads in the best of condition, and will post all bad and dangerous turns in the vicinity of Johnstown. The club sent a representative to Pittsburg to pilot the Pathfinder into Johnstown, and this representative continued with the party several miles out of Johnstown on the road to Bedford Springs. The scenery in the vicinity of Johnstown is excellent. Great towering peaks are on

one side of the highway, and in many places one can look down several hundred feet on the Conemaugh river.

The roads from Johnstown to Harrisburg are sandy and of red clay. The road from Johnstown to Bedford Springs is by Winber, Pleasantville, and over the Allegheny mountain. This is a more northern road than was taken last year. The Allegheny mountain is the highest peak of the Allegheny range and is struck about twelve miles west of Johnstown. The top of the mountain is a wild, barren waste of land, the timber having been cut off. The road over which the tourists will pass is the original roadbed of the timber railroad. The mountain is infested with black bear, wildcats, mountain sheep, and other wild animals. For five miles the Pathfinder drove through clouds so thick that the acetylene lamps had to be lighted. An altitude of 2325.6 feet was reached. On coming down the mountain, extreme carefulness will have to be exercised by the drivers in the contesting cars, as a skid of three or four feet would mean the hurling of the automobile to a deep ravine, something like one thousand feet below. The roads are very rocky with many dangerous curves. From the foot of the mountain to Bedford Springs, clay predominates. If the tourists have to drive over this road after two or three days' rain, the going will be hard and many cars are likely to be put out of the running.

The first real good roads and the first opportunity at speeding since the Pathfinder left Buffalo was on the macadam road from Bedford Springs to Harrisburg. The tourists will be taken from Bedford Springs over the same route as last year, as far as McConnellsburg. From Breezwood to McConnellsburg, a distance of seventeen miles, it is one long steady climb and coasting. The course is filled with many road breakers, which Dai Lewis has jokingly termed "marcelle waves." To the automobilist, these car breakers will prove to be terrors and extreme care will have to be used. From Breezwood to McConnellsburg



Thumping Over the Plank Road Into Pittsburg.



In Front of Soldiers' Monument at Blairville, Pa.

the Pathfinder coasted for a distance of three miles, the throttle never being disturbed in covering the entire stretch down hill.

Going west from McConnellsburg to Harrisburg, the road is through Chambersburg, one of the most beautiful towns in Pennsylvania. In 1864 the town was destroyed by Confederate cavalry. The road is very excellent; the highways are lined with massive maples and large old residences, surrounded by spacious lawns. The country is flat and rolling to Harrisburg. The roads are in excellent shape and the tourists can cut out a rate of fifty or sixty miles an hour without police interference. On each side of the highway are beautiful farms with fertile soil. Wilson College for girls is passed, and from there on level hard roads lead into Carlisle, past the Carlisle College, made famous by the Carlisle Indian football team.

Between Pittsburg and Harrisburg, no "speed limit" signs were seen. The only drawback to this course is the great number of tollgates through which the tourist must pass.

The fifth day's tour from Harrisburg to Milford will take the cars through Lebanon, Reading, Allentown, Bethlehem, and Easton, along the Delaware river, through the Delaware Water Gap and over the Blue Ridge mountains. The highways through Lebanon, Reading, and Allentown cannot be surpassed. Nowhere in the country, not even the famous New England State highways can surpass those over which the Glidden tourists will pass. After passing Allentown, soft clayish mud was struck, which made the going very slow for the Pathfinder. Time and again through this district, the car again sank to its running board and axles. One automobile was passed outside of Easton, being hauled through the mud by a pair of mules.

The sixth day's run from Milford will probably terminate at Albany, New York, although this has not been definitely decided upon by Secretary Lewis. Just where the route will go from Albany is uncertain, but it is safe to say that the finish will either be at Saratoga Springs or Buffalo. New England will be visited quite extensively.

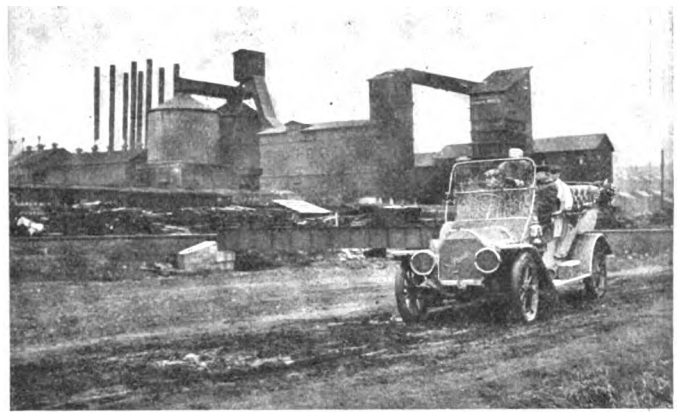

Among the Coke Ovens at Portersville, Pa.



Where the Road Leads Into the Town of Cramer.

**PHILADELPHIA IN TOUR; NEW JERSEY AVOIDED**

The route of the A. A. A. tour was changed on Monday last so as to include Philadelphia and still avoid New Jersey. Secretary Dai Lewis had reached the Delaware Water Gap, but Chairman F. B. Hower directed that he go back to Harrisburg and lay the route from there to Philadelphia.

The reason for eliminating New Jersey from the route of this year's tour is the motor law of the State. It was originally planned to run from Philadelphia to Atlantic City and spend Sunday at that resort. It would have cost the contestants about \$13 license fee for each car, however, for the two days, and so the State was avoided, and, instead of getting a reasonable fee, like other States, it will get nothing. Its principal resort will likewise be minus several thousand dollars that the tourists would have spent there but for the attitude of the State's lawmakers toward those who use automobiles.



Along the Conemaugh River Near Johnstown, Pa.

**CINCINNATI CLUB IS SIGN-BOARDING ROADS.**

CINCINNATI, O., May 11.—The Automobile Club of Cincinnati is busying itself with numerous activities at this season of the year, not the least important of which is the marking of the roads throughout the entire county. The opening of the new clubrooms in the Gibson House, which took place a few weeks ago, proved a veritable magnet, and the membership of the club has been increased by fully 100 recruits, Dr. C. L. Bonifield, the president, stating that the club has never been in such a flourishing condition before. The runs and tours committee is at present working on a hill-climb to be held May 23, and is also laying plans for an orphans' day in June.

**AUTO ENTITLED TO HALF THE ROAD.**

ERIE, PA., May 11.—It is not often that statutes dating back as far as 1820 have to be invoked in the trial of a case involving



Road Makers Preparing the Way at Johnstown.



Mountainous Road Near Carlisle.

employed a few miles out of the city. He was driving west on the Lake road, a little east of the Six-Mile schoolhouse, recently, when H. N. Fleming came up behind in a car. Repeated signals failed to have any effect, and when the driver finally man-



Where the Lowing Herd Was Encountered Between Windber and Bedford.

an autoist's rights on the road, but that is what was done at the instance of the Erie Motor Club's attorney in the prosecution of Herbert Hower, a farm hand, em-

aged to squeeze the car by at a broader part of the road, the obdurate rustic replied, "Why didn't you git it?" to an inquiry as to why he had not turned out. H. L. Moore, attorney for the Erie Motor Club, looked up the old statute and found that it provided for a penalty of \$20, which Hower was fined, together with the costs.

#### FERRY TO BENEFIT SOUTHERN TOURISTS.

PERRYVILLE, Md., May 11.—Now that a ferry is plying regularly between this place and Havre de Grace, tourists coming this way will no longer be subjected to the inconvenience of having to load their machines on a flat car and have them hauled across the railroad bridge. The first boat in the morning leaves here at 6:15 A.M. and the other side at 6:30, the schedule thereafter being half hourly until 8:45 P.M., the boats being run an hour later on Saturday, while the Sunday hours are from 8 A.M.

## FACTS ABOUT THE A. A. A. BUFFALO CONVENTION

**B**UFFALO, May 11.—Preceding the start of the annual A. A. A. tour from Buffalo, the national association will hold its first "Legislative and Good Roads Convention," in the preparation of which splendid progress is being made. Briefly outlined, this is the program that has been mapped out:

**Monday, July 6.**—Arrival, reception, and registration of delegates at the Iroquois Hotel, and special side trips to Niagara Falls, which is only 20 miles from Buffalo.

**Tuesday, July 7.**—Address of welcome by Mayor J. N.

Adam, with a morning session devoted to a discussion of "Uniform Automobile Legislation," under the direction of Chairman Charles Thaddeus Terry and members of the A. A. A. Legislative Board.

In the afternoon the subject of "Good Roads" will receive attention under the supervision of Chairman Robert P. Hooper and members of the Good Roads Board. State Highway Commissioners Hunter, of Pennsylvania; McClintock, of Massachusetts, and Skene, of New York, will be included among the speakers. In the evening the delegates will be entertained at a vaudeville performance at Shea's Theater.

**Wednesday, July 8.**—"Good Roads" will be further considered at the morning session, and early in the afternoon the delegates will be given a tour of inspection over new roads under construction in and about the city. County Engineer George C. Diehl, of Buffalo, is the chairman of the Committee on Practical Roads Construction. Demonstrations will be included by road builders on the maintenance and preservation of the highways, illustrating various methods for making roads dustless.

In the evening will come the banquet at the Iroquois Hotel, with President William H. Hotchkiss presiding. It is expected that Governor Hughes, of New York; Governor Stuart, of Pennsylvania, and Governor Harris, of Ohio, will be among the speakers.

**Thursday, July 9.**—Start of the Fifth Annual Reliability Touring Contest of the A. A. A., including the contests for the Charles J. Glidden trophy for touring cars and the Frank B. Hower trophy for runabouts, which will lead the tourists through 2,600 miles of picturesque country.



An Archaic Toll Gate Just Before Entering Harrisburg.



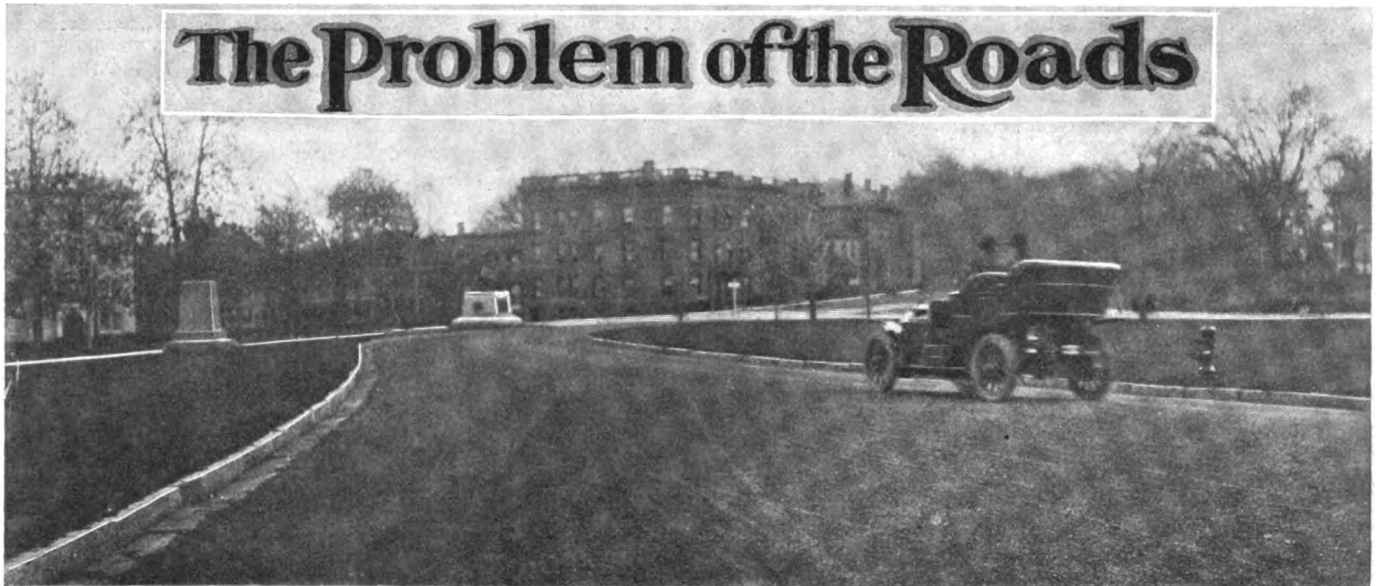

Coal Tar Treated Roadway South of the State Capitol at Hartford, and Leading Out of the Capitol Grounds.

**H**ARTFORD, CONN., May 11.—In the matter of improved highways, Connecticut has won an enviable position, and this is due in a great measure to the tireless efforts of State Highway Commissioner James H. Macdonald. It is the sole ambition of this official that before he shall have terminated his office and relinquished the reins to his subordinates that the State will be dotted everywhere with faultless highways. At the present time the roads of the State are, for the most part, very good, and the commissioner is ever active in an endeavor to eliminate the bad spots. But, like all other sections of the universe, Connecticut has the dust evil to overcome, and how to obliterate the nuisance is a phase of the situation to which the commissioner has given much thought and consideration. Last summer, for instance, crude oil or asphaltum was tried, and the results were quite satisfactory. Yet, anything that savors of improvement receives due consideration.

The commissioner is of the opinion that coal tar is about as efficient a road preservative and dust layer as there is to be had at this time. Some time ago the beautiful macadam drives which surround the State capitol at Hartford were treated to two coats of coal tar. Needless to say, these tar stretches have worn very well and resisted automobile traffic. The commissioner firmly believes that automobiles must necessarily have a deleterious effect on the highway, for he drives a car himself, and, likewise, is aware that dust is an evil to be banished.

When a representative of *THE AUTOMOBILE* called on Mr. Macdonald and asked him what he thought of tar roads, he took the inquirer to his office window, overlooking the roads, and remarked: "There they are; you know when they were laid. How do they look?" But the mere fact that someone was in quest of road knowledge rendered the commissioner all action, for he will resort to all sorts of methods to make one fully comprehend. He described the processes necessary for the construction of a tar road according to the specifications of the highway commission.

For instance, the tar may be applied only on a very hot day, and only after the dew is off the ground. First of all, the contractor who undertakes the work must pare down and shape all gutters in conformity with the original cross-section of the road. All cleanings and scrapings must be removed well to one side of the road to be treated. After the shoulders or gutters have been formed and shaped, all dirt or accumulations must be cleaned off, and for this purpose split rattan brooms must be used. The process of scraping and cleaning is carried on until the No. 2 stone is entirely exposed, and clean and free from all foreign material, so that there shall be no interruption between No. 2 stone and the primary coat of coal tar. Any toe marks,

ruts or depressions that may exist must be thoroughly swept out, and must be filled in with stone previously coated with coal tar. The coal tar used to saturate the road surface must, according to the State specifications, have about 15 per cent. of pitch melted into it, so that the pitch will become liquified and thoroughly mix with the tar. The stone used for repairs must not exceed one inch longest diameter, and shall be placed in such depressions as may be, and thoroughly rolled into the original fractures. Before the stone is applied to fill ruts and the like, the depressions must be slush treated to a coat of coal tar. After the road has been cleaned thoroughly, and all fractures repaired, the primary coat of tar is applied to the travel path.

The tar used must have been heated to 225 degrees Fahrenheit before application. After the tar has been flodded on the road, it must be broomed in thoroughly with heavy split rattan brooms. When the road surface has sufficiently absorbed the initial coat of tar, a second application is made. This must also be heated to 225 degrees Fahrenheit, applied in the same manner, and thoroughly broomed in, so that all interstices and voids

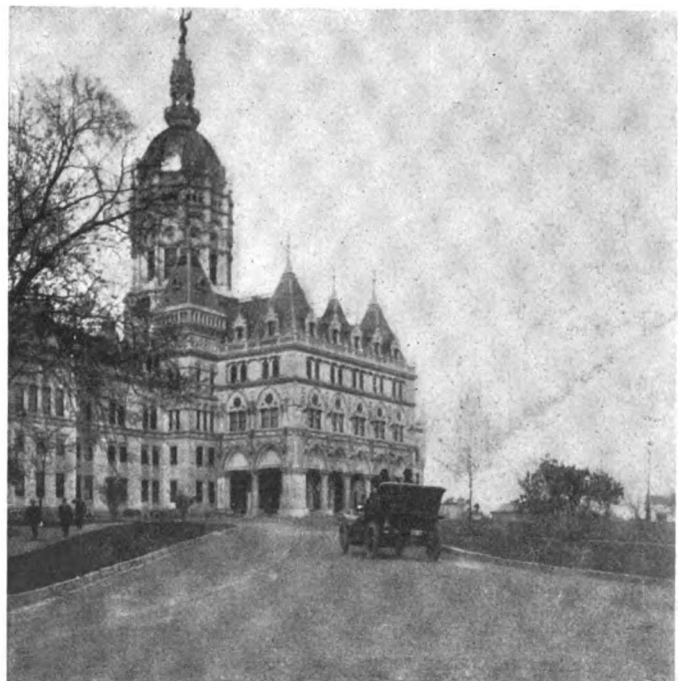

Making Turn at 25 Miles per Hour, Without Dust.



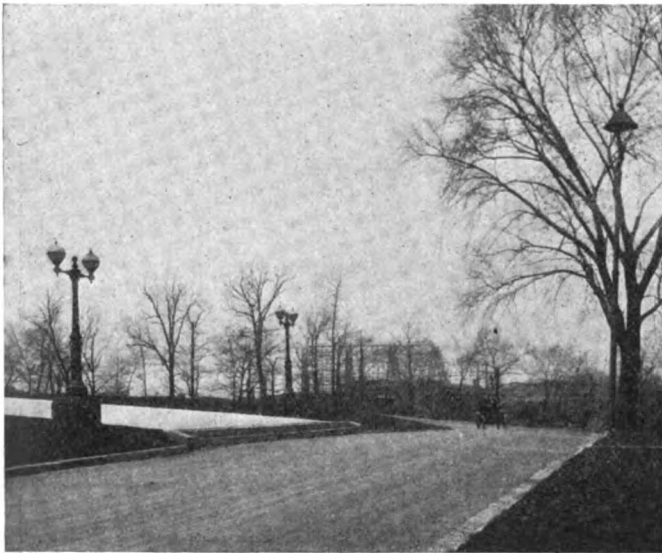

Tar Road on North Side of Capitol at Hartford.

The smooth, even surface is very noticeable. Automobile traffic is very heavy at this point, as this road is used as a short cut in circling the Capitol grounds.

will be completely filled. Following closely on this second application of tar is a treatment of chips, or, more properly speaking, of splinters of clean trap rock not exceeding 3-4 of an inch longest diameter. This layer of fine stone or splinters must be

applied while the tar is hot, and the depth must be at least one inch. Immediately after the application of the stone splinters, the entire surface is rolled down to thoroughly imbed the covering in the second coat of tar.

No water-gas tar may be used, nothing but pure coal tar being permitted by the commission. As previously stated, the day when the tar application is made must be dry and hot, and the road must likewise be very dry. No tar is permitted to be applied when indications point to a storm, or in the event of a storm, until twenty-four hours thereafter. The barrels containing the tar, before the tar is put in the kettles, must be laid on the sides, bung up, for not less than five hours, so that all water contained in the tar will come to the surface, and this must be removed before the tar is placed in the kettles. Only new and fresh stones and splinters can be used. A ten-ton steam roller is used to roll down the surface after the splinters have been applied.

It will be noted that the foregoing specifications are somewhat rigid, and roads constructed in conformance therewith should render the maximum of service. According to Commissioner Macdonald, the tar roads that surround the State capitol are absolutely waterproof at all seasons. These roads are perhaps more extensively used by automobiles than by horse vehicles, and just how well they wear is shown by the accompanying photographs. Every dealer in town who has a machine out for demonstrating purposes includes in the itinerary a run over these roads. Thus it will be seen they are much traveled. They are free from dust and present a smooth, hard surface. The commissioner contemplates treating other roads throughout the State with tar during the coming season.

## AN EXPLANATION OF WHAT COAL TAR IS MADE FROM

SO much interest has been aroused by the successful experiments in road preservation and dust-laying with the aid of coal tar that many would like to know what coal tar is, and just how it is produced. A little inquiry is sufficient to show that the average man has not the faintest conception of what this product is, so that the following information, gleaned from a recent report of the Bureau of Forestry, is timely.



Macadam Road Leading Northward from the Capitol.

This road is not tar treated, and the difference between the road shown above and this one is very noticeable, when comparisons of surface are made.

Coal tar is composed partly of the substance known as carbon, and partly of compounds of this carbon with the gas hydrogen, and which are known as hydro-carbons. When the coal tar is heated sufficiently, away from the air, the hydro-carbons are driven off in the shape of a gas. Illuminating gas is made by subjecting coal tar of the proper kind to this process, which is known as "dry distillation." The coal is put into a long, fire-clay oven, or retort, shaped much like a giant model of the cake commonly known as "lady fingers," the retorts being about 13 feet long, 2 feet wide and 16 feet deep. A number of these retorts are built side by side, in three rows, one above the other, the ends being supported on a brick wall, which also extends around the ends of the rows and over the top.

Fire, from furnaces below, is carried by flues into this enclosure, so that the retorts are entirely enveloped in flame, and can be heated to a very high temperature. The retorts are partly filled with coal and then sealed to exclude the air. They are then heated to a temperature of about 2,100° Fahrenheit. Under this intense heat, almost all the hydro-carbons pass off, leaving behind only the "fixed" carbon, in the shape of coke. As the gas comes from the retorts, it is a thick, yellowish green smoke, and must be passed through a series of costly machines before it can be used. Many of the compounds distilled will remain in the form of gas when cooled to ordinary temperatures when the original gas is cleansed from its impurities. In the condensers, which cool the gas, the heavier compounds are left behind in the shape of thick liquids.

The heavy, strong-smelling black liquid left behind by the first cooling is what is commonly known as coal tar. This is an exceedingly complex mixture of substances, from which are obtained costly perfumes, dyes, medicines and a host of other things, including flavoring extracts. Coal tar is also produced by what is known as the by-product coke oven, used for the production of coke for steel making. In recent years, gas has been made very largely by another process which produces what is known as "water-gas." This process also produces tar that is very similar to coal tar and difficult to tell from it.

## EXPERIMENTS OF THE OFFICE OF PUBLIC ROADS

WASHINGTON, D. C., May 11.—The subject of dust prevention, owing to its relation to road preservation, is of vital importance to the road builder. The Office of Public Roads carried on a series of experiments during the summer of 1907, with a view to determining, if possible, the relative value of various dust-laying preparations and crude products, and their adaptability to different conditions. The project embraced many details, and, owing to lack of funds and the difficulty in finding one road suitable for all kinds of experiments, had to be somewhat modified in the final plans and the work divided among three localities.

It was learned that the highway commission of Massachusetts intended to treat a stretch of road leading into Boston with tar preparation, and arrangements were made by which the Office of Public Roads could carry on a number of experiments on sections of this road. The road selected for the experiment was a mixed trap, and granite macadam in the township of

ture, and contained a good pitch base. The special coal-tar product was supplied free of charge by the manufacturing company in fifty-gallon barrels. It contained no water, was free from the extremely volatile oils present in the crude tar, and held a good pitch base.

The tar was applied during the month of August, and only in dry, warm weather. The method, in general, was as follows: All loose materials, dust and detritus were first removed by repeated trips of the sweeper, just before the application of the tar. Hot or cold tar, according to the experiment, was then spread upon the clean, dry road through a hose connected to the kettle, or tank wagon, as the case might be. Laborers followed the kettle, spreading and working the tar into the road surface with stiff, long-handled brooms. As the road could not be closed to traffic, it was found necessary to throw on a light covering of gravel or screenings almost immediately, in order to prevent passing automobiles from picking up the tar, although



Experimental Stretch of Coal Tar Treated Road at Savannah, Ga., on Henry Street, Looking Westward into the Suburbs.

Weston and Wayland, which had been built about ten years previously, and had but few repairs since that time. It is part of the main thoroughfare connecting New York with Boston, and is located about sixteen miles from the center of the latter city.

The automobile traffic is, for this reason, heavy, and this, in addition to teaming and other traffic, had produced serious results. In some cases, the macadam was completely broken through. There were many rut holes, some of them thirty feet long, and averaging from one to three feet in width, and a large number of smaller holes more clearly circular in shape. Over almost the whole road surface numerous small depressions or worn places were visible, and practically all of the fine material was being removed by traffic as fast as it was formed. The No. 1, or large stones, protruded above the surface, and in many cases were scattered loose, making the road extremely rough.

Sections of this road as nearly alike as possible were selected for the experiments, which were made with water-gas tar, crude coal tar, various mixtures of the two applied in different ways, and a special coal tar product.

The water-gas tar was obtained from a local gas company at \$1.50 per barrel of fifty gallons, delivered. It was a thin, oily liquid. The crude coal tar was also obtained from a local gas company in fifty-gallon barrels, at \$2 per barrel, delivered at Wayland. It had been produced at a comparatively low tempera-

ture, and contained a good pitch base. The special coal-tar product was supplied free of charge by the manufacturing company in fifty-gallon barrels. It contained no water, was free from the extremely volatile oils present in the crude tar, and held a good pitch base. The tar was applied during the month of August, and only in dry, warm weather. The method, in general, was as follows: All loose materials, dust and detritus were first removed by repeated trips of the sweeper, just before the application of the tar. Hot or cold tar, according to the experiment, was then spread upon the clean, dry road through a hose connected to the kettle, or tank wagon, as the case might be. Laborers followed the kettle, spreading and working the tar into the road surface with stiff, long-handled brooms. As the road could not be closed to traffic, it was found necessary to throw on a light covering of gravel or screenings almost immediately, in order to prevent passing automobiles from picking up the tar, although

it would have been much more satisfactory and productive of better results could the tar have been allowed to dry for a number of hours before applying the surface dressing. Finally, enough of the covering material was added to take up the excess tar and produce an even surface, and the whole well rolled with a twelve-ton steam roller until firm and smooth. When gravel was used, it was obtained from pits located near the road, and cost the highway commission about \$1.08 per cubic yard, during the time covered by the work of the office. One-half inch clean trap screenings or pea stone, however, was used whenever it could be obtained, and was furnished at \$1.10 per ton by a rock-crushing plant located about four miles from the nearest section of the work.

Thirteen different experiments were made, four with water-gas tar alone, three with coal tar, three with mixtures of water-gas tar and coal tar, and three with special tar preparations. Nearly all of the sections were in good condition when they were inspected in November. It is impossible at the present time to make decided comparison of the value of the different surfacings, but, undoubtedly, after the cold rains and the frosts of winter, conclusions may be reached as to the worth of each one, for these agencies are the worst enemies of work of this kind. Some facts of interest have already been noted which it may be well to mention at this time.

It has been shown that water-gas tar is a satisfactory dust layer and preventive when used in moderate quantities on



Another View of Henry Street, Savannah, Looking Cityward.

roads already in fairly good condition. It can undoubtedly be applied to the best advantage by means of an ordinary sprinkling cart on the unprepared road, and when used in this way serves to make the road surface firm and keep down the dust for some time at a very reasonable cost. Its odor is objectionable, but soon disappears. It must necessarily be applied more frequently than the heavier tars, owing to its lack of body. Where extensive repairs have to be made before, it has but little value as a binder for the large, loose material, and whether its use even in large quantities will be satisfactory for this purpose and for holding down a heavy surface dressing is a matter for the future to decide.

At the present time some of the experiments with crude coal tar show up favorably in comparison with the work with special preparations, but time is needed to decide definitely upon their relative merits. As regards application, the special preparation has the advantage over crude coal tar in being less inflammable and less likely to boil over the sides of the kettle if heated too high, but, on the other hand, its cost is considerably greater.

Two criticisms which have already been offered by farmers to both of these products are that the traction of heavily loaded wagons is increased, and that in frosty weather the road is made very slippery and offers but little foothold to horses. While the mixtures of water-gas tar and coal tar, with a light dressing of trap screenings give better results in these respects, it is impossible at the present time to say that their use will prove as satisfactory or economical in the long run. A material which can be applied cold is much easier to handle than one requiring heat, but, of course, the latter has the advantage of containing more binding material or base. Where surface dressing is needed the use of clean one-half inch screenings is certainly to be preferred to gravel, as less rolling is required and a better wearing surface is produced.

The surface treatment of roads with tar is more a palliative than a preventive of the dust nuisance. Some more permanent treatment of the road is essential for lasting results. It is the intention of the Office in the near future to carry on experiments along the latter line, with the use of a well-tarred sand to supply a part of the binding material and to fill the voids. One of the most promising methods with respect to cost which has suggested itself is to apply a layer of this tarred sand to the bottom course of No. 1 stones, which should first be well rolled. The second course of No. 2 stones should then be applied, and the whole rolled until the sand has been thoroughly worked into both the upper and lower courses. A surface application of tar should then be put on and sufficient sand or fine stone chips spread to bring the surface to a smooth and uniform condition when rolled, so that the whole structure will be firmly bound and proof against the usual rapid disintegration.

### SAVANNAH'S ROAD TARRING EXPERIMENTS.

SAVANNAH, GA., May 11.—As the result of the very successful manner in which that portion of Henry street treated with "gas house" coal tar more than six months ago has stood up, more work along the same line has been done. The first experimental stretch of road has been extended about 200 yards and the entire surface of the roadway saturated with the preparation. Farther out, the county commissioners have had about 1-8 mile treated in the same manner at county expense and will continue this into the city limits, so that there will be the better part of a mile of road thus prepared, which is subjected to heavy traffic. It will be closely watched during the summer. F. C. Battey, president of the Savannah Automobile Club, has been a moving spirit in having this work done, and has been successful in enlisting the interest of the county commissioners.

### PITTSBURG CLUB PRIZES FOR ROAD REPAIRS.

PITTSBURG, May 12.—By way of encouraging road repairs, the Automobile Club of Pittsburg has offered gold money prizes, aggregating \$175, to the township road supervisors or committeemen who shall construct King split log drags and by their use accomplish the greatest improvement in selected stretches of the main traveled roads under their charge, preferably those connecting with the macadamized roads of Allegheny county. The drag named is a simple device for use on dirt roads, which has been in practical use for the past twelve years with splendid results.

### ROAD CONSTRUCTION OUTSIDE DETROIT.

DETROIT, May 11.—With \$90,000 available this year as a result of taxation, and \$12,000 more coming from the State when the work outlined has been completed and accepted, good roads advocates in Detroit and Wayne county are in fine feather. The first bit of earth in what will eventually lead to a system of roads entirely covering the county was turned last week on Grand River avenue, a mile beyond the city limits, by the county highway commissioners, in the presence of State Highway Commissioner Horatio S. Earle and a large gathering of city and county officials and automobilists.

The ceremonies were of a practical nature, a heavy plough coupled to a massive steam engine being used to turn a deep furrow. From now on the work will be pushed with all possible speed, and it is hoped before next winter to have twelve miles of tar macadam road in commission on the principal thoroughfares leading out from the city. This will entitle the county to a reward of \$12,000 from the State, \$1,000 per mile being paid for macadam roads and \$500 for gravel when built in accordance with specifications furnished by the State. Next year it is planned to continue the work on an even more extensive scale, Commissioners Edward N. Hines, John S. Haggerty and William Murdoch having outlined an ambitious program.



Breaking Ground for Road Improvement Outside Detroit.

# AUTOMOBILE CLUTCHES AND THEIR DESIGN\*

By HENRY SOUTHER, MEMBER A. S. M. E. AND S. A. E.

CLUTCHES of one form or another, if one may judge from the literature on the subject, have been used since the earliest history of the mechanic arts, an important usage dating far back being in connection with wire drawing. It would seem, however, that clutches in general had attracted but little attention in the engineering world until recently, when they have been called upon to do the delicate work now required of them in connection with cotton mill machinery, printing presses, electric cranes, power plants, and, most recently, with automobiles.

The positive jaw clutch is necessarily used only where the character of the starting action is immaterial, and if sudden,

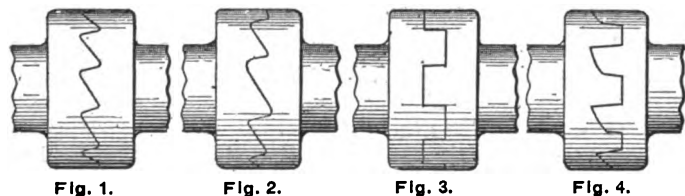

Various Types of Positive or Jaw Clutches.

matters but little. It obviously can be used only where the inertia of the standing of driven parts is relatively small, otherwise materials could not stand the wear and tear. Modifications of the positive clutch are made in the angles of engagement between the jaws. The least positive form is one where the planes of engagement are inclined backward as regards the direction of motion at an angle of 15 degrees, more or less. The tendency of such a clutch under load is to disengage. It must be held up to its work by an axial pressure, which may be regulated to perform a normal duty, but to slip and disengage when called upon abnormally by some accident or overload.

Positive clutches with engaging planes parallel to the axis of rotation must be held up to their work to guard against a natural tendency to jar out, but they present no safety features against an overload. More extreme yet as to positiveness is the so-called undercut engagement of the jaw clutch, the tendency of which is to engage the tighter when loaded; and which can be disengaged only when absolutely free from load and in a condition to be rotated in a reverse direction sufficiently to overcome the undercut angle. In automobile construction the positive type of clutch is used inside the gear box, so arranged as to be operated only while the main friction clutch connecting the engine with the driven shaft is disengaged. This positive clutch sometimes takes the form in automobiles of an external spur gear meshing with an internal spur gear. Automobile gear changing systems are used that keep all gears in mesh all the time. Each gear carries a positive jaw clutch to be engaged with mates on the driving shaft, while the main friction clutch is temporarily held out of engagement.

Several inventors of merit have accomplished this same thing by a sliding spline, or a hardened ball, on the driven shaft, which engages with the gear hub internally. Such forms are in use, but it cannot be said in common use. It will be seen that this use of a positive clutch in connection with the automobile is one where there is little inertia to be overcome, the mass to be started being only a small shaft within the gear box and the gears on it. The chances are that even these are rotating to some extent in the direction in which they are to continue to move. After this positive clutch is once engaged the main friction clutch comes into play. No drag of the friction clutch is permissible.

\*Paper read before the American Society of Mechanical Engineers at New York, May 12. Discussion to be continued at Detroit, June 25-28, in conjunction with the Society of Automobile Engineers.

The starting crank of an automobile is a first-rate illustration of an under-cut positive clutch. It is under-cut so that when the hand is applied to the starting crank there is little or no danger of the clutch slipping off and wrenching the operator. It is a fact, however, that some of these clutches are not under-cut and are disagreeable to handle for this reason.

## Classification of Friction Clutches.

A rather careful search of the literature reveals the fact that there are basic types, few in number, involved in all clutches, but that there is an infinite variety of detail of construction and manipulation. Rankine differentiates between friction clutches about as follows:

Friction clutch (contracting band).

Friction cones.

Frictional sector (invented by Bodmer).

Friction disc (Weston's invention).

Reuleaux illustrates the Ramsbottom clutch as used for rolling mill work. This is nothing more nor less than a friction coupling in which one flange is squeezed between frictional surfaces by being tightly bolted. Referring to Fig. 5, the flange attached to part A is firmly clamped between the wood-lined surfaces of B, adjustment of the bolts being such that the friction will resist normal torque but yield to abnormal torque. This is perhaps the most simple form of friction clutch. It would seem as though some such device might well enter into the transmitting portions of an automobile, so adjusted as to resist up to, say, one-half the elastic limit of the parts involved, and slip under the application of any greater load. Right here it is well to point out, however, that many mechanical devices which have performed well elsewhere have performed badly in automobiles because of the unusually variable conditions to which an automobile is exposed, which might prove to be true of this clutch.

Reuleaux then shows as the next step in the development of the clutch a cone coupling, the two parts being forced into engagement by screw and handwheel B, as shown in Fig. 6. He states that the angle of the cone should not be less than 10

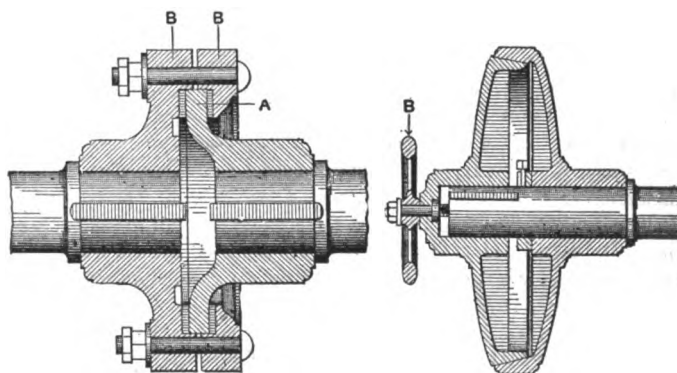

Fig. 5—Ramsbottom clutch.

Fig. 6—Cone clutch.

degrees, in order that the parts may not become wedged together. He also gives in connection with this clutch with frictional surfaces of iron on iron a coefficient of friction of 0.15. In order to keep the axial pressure within reasonable limits, he places the mean radius of the cone between three and six diameters of the shaft. Following the single cone clutch in Reuleaux is what might be called a multi-cone, as shown in section by Fig. 7, a series of concentric cone-shaped rings with angles of 10 degrees, or 20 degrees for both halves of the cone. As shown in this cut, it is apparent that the collar would have to resist the pressure and wear due to the axial pressure necessary for proper engagement. This would be serious.



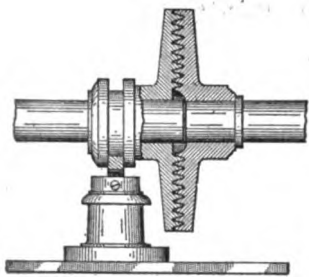

Fig. 7—Multi-cone clutch.

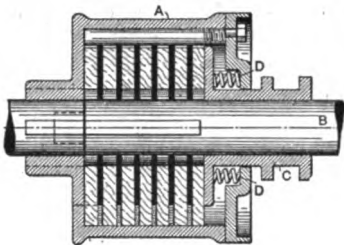

Fig. 8—Weston clutch.

Such wear is avoided in heavy machine work or in high-speed automobile design by making the axial pressure self-contained on the rotating member, except when the clutch is in the act of being disengaged. Such construction as this has been found absolutely necessary in connection with all automobile clutches. This modification of the foregoing is shown in Fig. 9. The pressure of the screw wheel is self-contained, the two halves *A* and *B* being clamped together by it, the concentric double-faced cones furnishing much friction at slight axial pressure.

The next clutch shown by Reuleaux is that which he attributes to Koechlin, Fig. 10. This is of the internal expanding type, three internal clamp pieces, *A*, fitted with bronze shoes, being thrust out against the enclosing cylindrical drum *B*, by means of lever and screw action. Reuleaux points out the fact that there is no danger of wedging in this clutch, as exists in connection with the cone clutch. Reuleaux next shows a form of "axial friction coupling," well-known as the Weston clutch, based on the principle of multiple plate friction, Fig. 8. The plates are alternately wood and iron, as indicated, the wooden ones engaging with the outside cylindrical containing-case *A*, and the iron ones with the shaft, *B*. In the form shown, the plates are pressed together by springs, *D*, and released by drawing back a collar, *C*, which releases the spring pressure.

**Some Machine Shop Clutches.**

The foregoing reference to Reuleaux will serve to fix in mind the fundamental or basic types of clutches, and I will now give a number of illustrations to show the development of the machine shop clutch from the earlier forms already illustrated. Perhaps the simplest is the type in which one flat disc presses against another, the surfaces being leather against iron, bronze against iron, or wood against iron, the axial pressure being great enough to drive the maximum load, yet not so great but that slipping takes place when the load is first applied, which prevents all jar. Such clutches are familiar in the driving of looms.

In Fig. 11 is a modification of the Weston type. It is not multi-disc, there being only one wooden disc *A*, attached to the enclosing case *B*, which is gripped between two iron surfaces *C*, keyed to the driving shaft. To prevent any drag when disengaged, separating springs *D*, are supplied, which part the frictional surfaces when idle. Slight rubbing when idle is not a

very serious matter in machine shop clutches, however, but its importance in connection with automobile clutches I will bring out later. It is interesting to note that very little information is given or obtainable in regard to the frictional capacity of these machine shop clutches. Correspondence with the manufacturers reveals the fact that knowledge of the capacity of their clutches is of an empirical character. The coefficient of friction of maple (which is commonly used by them) on cast iron is known. Little use can be made of this knowledge, however, as the degree of lubrication, or lack of it, may easily double or halve this coefficient. The manufacturers have learned by experience what size clutch of their own make is necessary for the transmission of a given horsepower. Catalogues usually give the horsepower that can be transmitted at 100 r.p.m. It is probable that information of this kind, untechnical though it be, is decidedly more reliable than that obtained from any formula containing an unknown variable—the coefficient of friction.

What was formerly known as the Frisby clutch was designed many years ago when no attention was paid to mathematical design, but its capacity has been well established by experience. Fig. 12 shows this clutch, which is not unlike the last one described, except that a flat surface *A*, and cone *B*, are used in combination. The gripping of the surfaces is accomplished in very much the same way. The frictional surfaces are sepa-

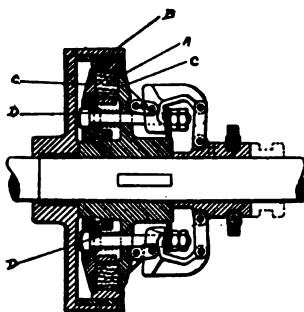

Fig. 11—Modification of Weston type.

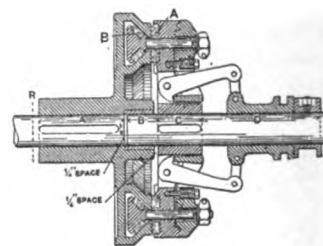

Fig. 12—Combined cone and flat surface.

rated by springs when disengaged. It is apparent that this clutch would require less axial pressure for any given horsepower transmitted than the foregoing type because of the cone; or, in other words, for a given axial pressure would transmit more horsepower, and, therefore, would be smaller and more compact, all other things being equal. But here again is the uncertainty of the coefficient of friction. This clutch, for example, might throw its oil to the frictional surfaces more than the previous example, which oil would more than offset the effect of the cone engagement.

**Clutches of Small Dimensions.**

A strong demand has developed for a clutch of very small dimensions for a given capacity. This demand has been met in rather a curious way. Instead of cast iron or metal of ordinary strength, hardened tool steel frictional parts have been resorted to. This permits exceedingly high normal pressures between the frictional surfaces. As much as 100-horsepower has been transmitted at 1,000 r.p.m. with a clutch containing friction rings 5 1-4 inches diameter and 1 1-2 inches wide. This form of clutch has been largely introduced into automatic machines, machine shop countershafts and launch engines. Its engagement is apparently soft enough for any of these purposes, but in connection with automobile service it is yet in the experimental stage.

**Clutches with Cork Friction Surfaces.**

In connection with the commercial clutches of the forms now under discussion, cork has recently entered the field to a considerable extent and apparently with considerable success. It has a high coefficient of friction, probably double that of wood

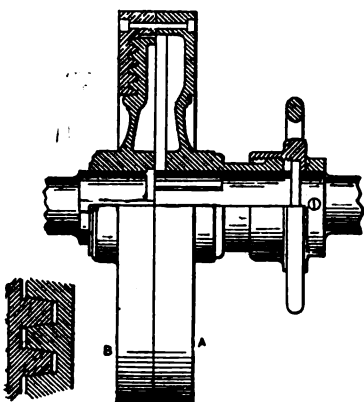

Fig. 9—Self-contained thrust.

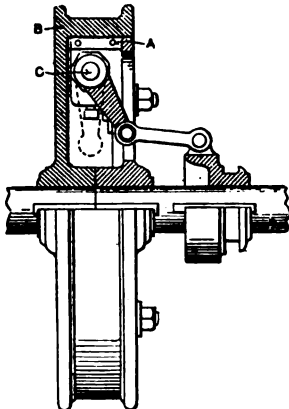

Fig. 10—Expanding type.



The axial pressure in connection with such clutches is usually furnished by a spring disc; that is, the steel plate which carries the frictional surface, either leather or copper, is caused to operate like a diaphragm spring. The amount of normal surface pressure is not known in most cases as far as I have been able to learn. The above figures in this regard were furnished by the Cadillac Motor Car Company, of Detroit. The diameter of a clutch of this kind ordinarily used to propel a car of 7 horsepower or 8 horsepower is from 5 inches to 10 inches, the rubbing surfaces being about one-half to three-quarters of the entire superficial area of the disc. Such clutches are mostly available for two-speed cars, the disc clutch connecting with the engine direct and running at engine speed, the planetary system being used only for low speed and reverse work, actuated by contracting band clutches.

Motor vehicles so geared have their uses, but early in the development it was found that three or four speeds were desirable. Boxes of sliding or change gears were resorted to, and here the character of the clutch became of prime importance. To be satisfactory, an automobile clutch used in this manner must engage and disengage easily, requiring but small axial movement of the operating mechanism, or of the clutch itself. It must be entirely independent of centrifugal force, and able to slip for a reasonable length of time without being destroyed.

The matter of absolute disengagement is perhaps the most important. Without it the sliding gears intended to be operated when the clutch is free or disengaged cannot be unmeshed nor remeshed. The slightest drag or friction in the clutch means a savage clashing of gears when changed. This means the destruction of the gears and the failure of the entire system of gear change. The early history of the art is full of failures in the matter of successful construction and operation of the so-called sliding-gear transmission. Gears with the teeth worn away were the rule rather than the exception. This wearing was, no doubt, due to the imperfect disengagement of the clutch. The use of a system of gear change requiring the clashing of moving gears cannot receive the complete approval of the engineering world; yet this system has become a success by a combination of improvements in clutch and materials of which the gears are made, and treatment of the materials.

An important feature in the clutch is the question of its weight, especially as affecting its inertia. A clutch having high flywheel effect spins to such an extent as to cause violent clashing of idle gears. Consequently, clutches are made as light as possible, and the smaller in diameter the better. Aluminum enters largely into clutch construction for this reason. The spinning of the clutch has been met in many automobiles by a so-called clutch brake—a retarding finger which operates in connection with the clutch disengaging lever and bears upon some portion of the driven member of the clutch, braking it to a standstill.

One inventor has gone still further in this direction and disengages the driven shaft both before and behind the gear box. This invention is such that the friction clutch opens first, immediately followed by the opening of a positive jaw clutch behind the gears and then braking of this disconnected driving shaft, as just described. This permits the engagement of gears that are absolutely free and stationary. It may be well to bring out the fact, however, that this invention is open to one objection, and that is that the gears may stop in such a position as to make it difficult to mesh them.

Any automobile clutch must engage smoothly and absolutely without shock to be called a success. The quicker it seizes without shock the better it is. Clutches exist that can be engaged suddenly and still not jar the passengers. But such a clutch is open to one very serious objection; that of not picking up the load quickly enough on a hill to start the car forward after a change of gears, before the momentum of the car is materially lessened. For example, in changing from the high gear to the next lower on a steep hill, a clutch that is too soft will permit the speed and momentum of the car to drop to such an extent that when the clutch finally does take hold the car is nearly at

a standstill. This necessitates a further drop into a lower gear; one that will start a car from a standstill on a hill. The clutch designer is, therefore, between two fires; too little slip on one hand and too much slip on the other. A degree of slip between the two must be found, and once found be capable of being maintained. It is doubtful if such a problem exists in connection with clutches anywhere else in the mechanical art.

The customary location for an automobile clutch is within the flywheel or at least at the rear end of the engine, if the flywheel is at the front end.

The application of the multiple disc type takes very little room between the gear box and the clutch, and would be too close construction (as will be shown later) for the application of the cone type of clutch, which requires so much flexibility back of the clutch.

#### Details of the Cone Clutch.

I will take up the simplest form first, namely, the cone. I am pretty well satisfied, that, all things considered, it is the best form when properly designed and mounted. It has the advantage of engaging and disengaging with very small axial motion. Axial pressure may be low because the normal pressure between frictional surfaces is multiplied by the angularity of the cone. Its weight may be very small, as the male member may be of aluminum. Its engagement is entirely independent of speed and centrifugal force. No liquid lubricant is needed with attending viscosity, drag and change due to wear and temperature. Disengagement may, therefore, be made perfect.

Proper engagement, however, has proven to be a very difficult and baffling problem. I think it safe to say that this difficulty has caused nearly all the rejections that have occurred of the cone clutch. A cone clutch may operate almost as savagely as a positive jaw clutch. It may also refuse to engage, if it does not have the proper combination of angularity, pressure and lubrication. It may behave well at times and very badly at other times. A cone clutch of given angles and dimensions, with a definite axial pressure, may be a success in one car and an absolute failure in another.

The cause of this contradictory behavior may not be and often is not in the clutch proper; but, on the contrary, in the surrounding mechanism of the clutch. The cone clutch must be absolutely free to center itself and seat itself uniformly. A short Oldham coupling or a single universal joint between the clutch and the driven shaft of the car is not enough to permit this under all conditions. The weaving of the frame of the car puts cross strains on such a coupling, causing it to bind and causing the clutch to seize on one side before the other and be drawn suddenly into full contact. A change of angle, increased lubrication and a change of materials on the friction surface will not remove the trouble arising from this cause. A pair of generous, free working universal joints must be provided, in order that the cone shall reach its seat as intended.

Similarly, an engine mounted on a flexible sub-frame or pan support may move sufficiently to prevent the proper seating of the cone and cause a similar line of troubles. The male member must be mounted so as to be flexible enough to follow such small movements. Experience has been a long time in teaching engineers that so much trouble can arise from apparently so small a cause; yet there are cases where misbehaving clutches have become well-nigh perfect by the introduction of flexible couplings.

Leather (riveted onto an aluminum cone) usually forms one of the rubbing surfaces and gray cast iron the other. It is desirable that the leather shall be kept soft by neatsfoot or castor oil. Some builders boil the leather in tallow before applying to the clutch surface; others do not, but this matter is of minor importance compared with the mounting. With leather 1-4-inch to 3-8-inch thick, properly softened, engagement may be sufficiently mild, but an improvement is obtained by placing under the leather at six or eight points on the periphery of the cone flat or spiral springs that cause the leather to engage at these points a little bit before engaging elsewhere.

(To be continued next week)

## LETTERS INTERESTING AND INSTRUCTIVE

### EXCESSIVE CURRENT CONSUMPTION CAUSES.

Editor THE AUTOMOBILE:

[1,351.]—In "Letters Instructive and Interesting" of the issue of the 30th, we note No. 1,335 letter regarding a coil vibrating when the spark plug is disconnected from the engine. Now we have just purchased a new Buick, and we find that the secondary wire can be disconnected from the plug on one engine and the coil buzzes just the same. Now from your answer to No. 1,335 we cannot take that our coil is working right. If our coil is short-circuited, would it cause our batteries to run down more rapidly than otherwise? That seems to be our main trouble. A new 60 ampere hour storage battery and 5 new dry cells only run the machine about 600 miles. Would you advise an Eisemann magneto for a two-cylinder car?  
Ravenna, O. G. W. CURTISS.

Our answer to Subscriber, Fair Haven, Vt., in this issue serves to reply to the first part of your letter. The coil should vibrate whenever a current is sent through its primary winding, but it should not vibrate simply because the spark plug is removed. In other words, the operation of disconnecting the plug should not cause it to vibrate independent of other causes. But the mere fact that the coil vibrates with the plug disconnected does not show anything one way or the other. If the coil were short-circuited, it would not work at all, and the batteries would be run down in a very short space of time, probably not more than half an hour. Either dry cells or accumulators should run your car 1,500 to 2,000 miles or more, without becoming exhausted. In all probability you will find that the coil vibrators are so poorly adjusted that they are taking an excessive amount of current. To remedy this, test them with a coil current tester, or low-reading pocket ammeter, which has a scale reading from zero to 3 or 5 amperes by tenths.

Disconnect the battery from the coil to be tested, and connect this wire to one of the terminals of the instrument; connect the other terminal of the meter to the coil where the battery wire was taken away, thus inserting the ammeter in the primary circuit. The engine should then be run and the adjusting screw of the coil vibrator turned up or down, until the engine will run steadily on a current consumption not exceeding .50 to .75 ampere. The needle will flutter constantly, but its range of movement is not sufficiently great to interfere with effecting the adjustment. Do the same thing with the other coil. If you will adjust both coils not to take more than .75 ampere, you will find that the batteries last twice as long. Take a look at the timer also, to see if there is anything wrong with it. An Eisemann magneto is an equally valuable investment on a two-cylinder car as it is on any other, but it is not so much of a necessity owing to the fact that the two-cylinder car of the four-cycle type only fires once per revolution, as compared with multi-cylinder motors.

### EXPERIENCE WITH INTERNAL TIRE PROTECTORS.

Editor THE AUTOMOBILE:

[1,352.]—Being a subscriber, I would like to know your experience, if any, with internal tire protectors, a series of steel discs laid in a band of canvas, and set between the tube and the shoe. If you have no personal experience of which you can advise me, I would appreciate it to know what faults, if any, have come to your knowledge regarding these protectors. E. EISEMANN.  
New York.

We have never had any experience with devices of the type you mention, nor have we ever heard of the particular one that you speak of having developed any faults, which means, in short, that we have not heard anything concerning it in actual use. The idea looks attractive at first sight, but whether it is practical or not has to be determined by experience. If any of our readers have used these internal tire protectors we should be glad to hear from them, publishing their experience in these columns.

### MORE ABOUT COIL VIBRATOR DIFFICULTY.

Editor THE AUTOMOBILE:

[1,353.]—I note in your answers to letters No. 1,311 and No. 1,335, that you state the coil should not vibrate when the wire is disconnected from the spark plug. Now I have tried this on a number of types of motors and the coil always vibrates when contact is made at the timer, whether the spark plug is connected or not, other connections being all right. Now, why should not the coil vibrate? I think your answer is misleading, as you perhaps misunderstand No. 1,311's letter. A SUBSCRIBER.

Fair Haven, Vt.

Upon rereading letter No. 1,311, in the light of your communication, we can see where the answer thereto is misleading to a certain extent. In stating that the coil should not vibrate when the plug was disconnected we did not intend to imply that this should not be the case simply because the plug was not connected up, but that the operation of disconnecting the plug should not cause the coil to vibrate. As the vibration of the coil trembler is caused by the current passing through the primary coil and energizing its core, thus attracting the vibrator armature, the latter interrupting the current by its movement, this operation is entirely independent of the spark plugs, or, for that matter, of the secondary winding of the coil, and if the coil will not vibrate when contact is made at the timer it is naturally to be inferred that there is something wrong with the battery or the connections. The closing statement of the answer in question, that "the coil should only vibrate when contact is made at the timer, as intended," should cover this point.

### ATTEMPTING TO DEFINE THE STOCK CAR.

Editor THE AUTOMOBILE:

[1,354.]—The Automobile Club of Wilmington is planning to hold a road race for stripped stock cars, and I would thank you very much if you will answer the following questions through your "Letters Interesting and Instructive," so that we may get some definite ideas as to what constitutes a stock car.

1. Is it permissible to change the gear ratio from that supplied on the car when delivered from the factory?
2. Is it permissible to increase the size of the rear wheels so as to increase the speed of the car without increasing the gear ratio?
3. Is it permissible to remove the entire body and substitute instead a body of different type?
4. Is it permissible to remove the gasoline tank and substitute a smaller one, so as to take up less space?
5. Is it permissible to substitute flatter and lighter springs so as to bring the center of gravity nearer the ground?
6. Is it permissible to attach a tire pump to the gasoline tank so as to pump air into said tank to cause the gasoline to more readily flow to the carbureter, if this car when shipped from the factory is supplied only with a gravity feed?
7. Is it permissible to increase the compression of the motor by placing plates either on the top of the pistons or in the top of the compression chamber?
8. Is it permissible to install a type of carbureter different from that originally supplied by the manufacturer?
9. Is it permissible to install a magneto on a car not equipped with one by the manufacturer?
10. Is it permissible to remove fenders, mudguards, running boards, dustpans and mufflers? If it be permissible to remove fenders, is it permissible to install instead fenders of lighter construction?

Our rules as drawn up merely provide that all entries shall be stripped stock runabouts listing for \$900 or less, as equipped by the manufacturer. BURKE H. BRIDGEIS.

Wilmington, N. C.

1. This is commonly done, but we do not think it should be allowable, as, if the car is geared especially for racing, as is the case where the change is permitted, it is no longer a stock car.

2. The answer to question No. 1 would apply to this equally. Taking the meaning of the phrase "stock car" in its every-day significance, it is evident that such changes would not be allowable, as it would not be possible to go



to the manufacturer's plant and pick out a car with an unusually high gear or unusually large wheels. They would be the same on the whole series of cars of that model being turned out, and altering them in such important essentials would be radical changes made solely for the purpose of gaining extra speed.

3. Yes. The usual racing seats are generally allowed. This does not change the chassis in any particular, and this, after all, is the "car."

4. Changes in the gasoline tank are also permissible, a larger one generally being employed.

5. This is another alteration that would take the entrant out of the stock car class, as with special springs it would not conform to the requirement that the maker should have built a certain number of duplicates of the car entered.

6. Special arrangements for feeding fuel and lubricating oil are usually permitted, as they are usually necessary to sustain high speed for any length of time.

7. Naturally not. Nothing could be further from the definition of a stock car than one which had been tinkered with in this manner. The product of such expedients would be something that was neither a racing car nor a stock chassis.

8. Interpreting the requirements strictly, this would not be permissible.

9. The answer to the preceding query would also cover this, but in view of the fact that both carbureters and magnetos are purely accessories, and, in the case of low-priced cars, seldom, if ever, built by the maker of the car, it would not be necessary to stretch the rules very much to make substitution of either of these essentials permissible.

10. As such races are always for "stripped" stock cars, this naturally permits of the removal of such superfluous parts as fenders, and it is equally allowable to substitute others of a lighter nature, such as strips of cloth. Racing rules for such cars sometimes permit the removal of mufflers, and in other cases merely allows them to be cut out, but not removed. Their removal, however, would appear to be a legitimate part of the stripping process.

The statement following your queries concerning the definition of a stock car, and which ends "as equipped by the manufacturer," would appear to us to put an effective quietus on any attempt to change gear ratios, wheels, carbureters, install a magneto or undertake any of the numerous expedients that you have mentioned, as any one of them would be digressing this very important part of your rules. It seems to us it should not be difficult for you to settle the question, as any low-priced car is a stock car pure and simple, in the shape that its owner purchases it. Removing fenders and the like and putting on special racing seats makes it a stripped stock car. What more is there to it?

### GOOD SUGGESTIONS FOR FORD OWNERS.

Editor THE AUTOMOBILE:

[1,355.]—I was much interested in letter No. 1,324, by Charles Gilbert, explaining changes which he had made in the gasoline pipes on his Ford runabout. Once or twice last summer I had similar trouble, although did not find out at the time what was the cause. I wrote the Ford Company, who advised me that the location of the gasoline connection was too close to the exhaust and should be changed, as they have been doing for quite some time, in their later cars. On reading the above letter, I at once saw a simple way of accomplishing this, and for the benefit of others will explain just what I did. I obtained from a plumber's supply shop a 1-2 inch diameter by 11-2 inch nipple, a second one 1-2 inch by 4 inches, and two elbows to fit. I found these dimensions correct, so that the location of the parts was exactly in the right place when reassembled. I attach herewith sketch showing this arrangement, and would suggest that each owner of the Ford cars which have the hole in the gasoline tank almost directly over the exhaust pipe, should make this change. This will remedy a great majority of their so-called "carbureter" troubles. The cost of these four parts is about 50 cents. Be sure to get them of brass, however.

A very tantalizing trouble which I have had recently and how I overcame it might also be of interest. Very frequently No. 3 cylin-

der would fail to explode, and the trouble seemed but slightly remedied after putting in new primary wires. I then thought that perhaps the trouble might be in the commutator, and while it appeared clean, I nevertheless put a little piece of emery cloth on a little stick and polished the No. 3 contact point in the commutator, then thoroughly washed all dust and dirt out with gasoline, and have not had a misfire since.

I hope that some of your readers may be benefited by the above suggestion.

W. S. HAGAMAN.

Sharon Hill, Pa.

The manner in which you diagnosed the difficulty and overcame it is not alone very interesting, but should prove valuable to numerous owners of similar cars. We have noted the sketch showing the change, but as it is practically the same as that submitted by Mr. Gilbert have not reproduced it.

### WORTH FIFTY TIMES A YEAR'S SUBSCRIPTION.

Editor THE AUTOMOBILE:

[1,356.]—Through your "Letters Interesting and Instructive" I have gained more general knowledge of details of the ordinary automobile engine than can be gotten for fifty times the cost of your paper, but there is a question that has not been answered, to my satisfaction at least. Will it be wise or unwise practice to use a paste of cylinder oil (good grade) and graphite, half and half, to lubricate and reduce noise in a selective sliding gear transmission and roller bearing differential assembly? Desire to thicken lubricant to prevent throwing out at bearings and brake hubs respectively.

W. H. GERHARD.

Austin, Texas.

This practice is highly recommended by some authorities and at least one manufacturer turns out a special compound consisting of graphite and wood chips or shavings especially intended for use in change speed gears. You will find an inquiry concerning this subject in the issue of THE AUTOMOBILE of April 23, page 569, Letter 1,321, together with the answer thereto, and we are since in receipt of a letter which is published in last week's issue of THE AUTOMOBILE, stating that the writer had tried various forms of sawdust without satisfaction and had found that cork filings and oil gave the best service.

### COMPOUND FOR FILLING PNEUMATIC TIRES.

Editor THE AUTOMOBILE:

[1,357.]—Will you please give me, through "Letters Interesting and Instructive," a formula for some good compound to fill tires with?

A SUBSCRIBER.

Portsmouth, O.

We do not know a good formula for this purpose and consequently hesitate to give you any. Common sheet glue and molasses in the proportion of one pound of the former to three pints of molasses will make a puncture-proof filling, but it will not be all that is desired by any means. Any good formula of this kind is naturally a trade secret and is likewise beyond the reach of the amateur to duplicate successfully, as it is necessary to put it into the tires under considerable pressure, requiring special machinery. Once a tire that has been treated in this manner shows signs of failing, the only thing to do with it is to throw it away, as it cannot be repaired and is of no further use.

### REPAIRING A LEAKY HONEYCOMB RADIATOR.

Editor THE AUTOMOBILE:

[1,358.]—Will you please favor me with directions for repairing a leak in my radiator? The leak is a slight one in a "honeycomb" type radiator, and I believe that it is possible sometimes to repair such a leak without taking down the radiator and soldering it. If a repair can be effected by running some solution through the water system, I am sure that any information that you can give on the subject will be of great benefit to others as well as to myself.

Pasadena, Cal.

J. H. STONE.

There is no way of repairing such a radiator, or any other type for that matter, by merely injecting something into the cooling water. At least we do not know of any. We should advise taking the radiator down and having it soldered by a good mechanic, as a bungler with a soldering iron will do more damage in ten minutes than can be repaired in half a day. It is a delicate job and requires a good hand.

### ARE SPECIAL STEELS ONLY A FAD?

Editor THE AUTOMOBILE:

[1,359].—During the past two or three months there has been appearing in the daily press a certain short article which recurred with some frequency in different papers, with an occasional change of wording, and which conveyed in substance the impression that "special steels" are of no special value in automobile construction, except perhaps here and there, for the purpose of reducing the weight of a part. The note has usually been coupled with the name of Hayden Eames, and with the output of certain automobile factories, and the "special steel" has been contrasted with ".50 carbon" steel as a material supposed to afford all the strength required. Finally this same item appeared a few days ago in two New York dailies, and, as it deals with a subject of enduring interest to the public, as well as to automobile manufacturers and to the whole independent section of the steel-making industry, I wish you would kindly allow me space for some remarks intended to present this subject in a more correct light.

From the standpoint of economy, a good deal may be said in favor of simple, ordinary carbon steel, so long as the carbon content does not exceed about 15 "points," meaning 15/100 of 1 per cent. Such steels may be handled successfully by the average workman. They may be successfully surface-hardened for gears, and the danger of overheating them in forging is not great. But, with higher carbon content the case is different. A 50-point carbon steel is difficult to forge, easily spoiled by overheating, and when used for gears, either too brittle or not hard enough. Its "life," or durability under shock and alternating stresses, is short, or at least precarious, and it is, in fact, the principal mission of "special steels" or alloy steels, as they are more commonly known, to obviate just those difficulties encountered when increased strength is sought through increased carbon content in ordinary steel. The most valuable alloy components are not only hardeners, as carbon is, but also tougheners, which carbon is not.

Mistakes have been made, to be sure, in alloy steels, especially by having their carbon content too high, but it is easily possible at the present stage of progress in alloy steel manufacture to select alloy steels which possess greater strength than 50-point carbon steel, and which couple with this greater strength, greater toughness than is possessed by any ordinary steel, and also perfect suitability for surface-hardening and much increased life under the shocks to which all automobiles are subject.

The principal error which has been committed so far with regard to special alloy steels has consisted in failure to draw a sharp line between the safe, low-carbon, alloy steels, on one side, with their moderate but distinct all-around superiority over ordinary low-carbon steel, and the more ultra alloy steels which promise superlative possibilities for special purposes, if made just right and worked just right, but in which the dangers of any high-carbon steel for construction purposes are accentuated. This division line among alloy steels is only the same which experience in other industries has drawn between ordinary low and high-carbon steels.

Alloy steels have had a vogue, it is true; and some have suffered by following the vogue rather than the sense behind it. Now the pendulum is swinging back, and the time may seem favorable for pronouncing 50-point carbon steel good enough, since it is economical to the manufacturer by its relatively low price, and economy is a perfectly legitimate consideration. But it proved a failure in bicycles; it has been definitely rejected as construction material for racing cars and in ball bearings, and for every other application in which the presence or absence of the properties required for continued resistance to shock is subject to rapid and conclusive demonstration. It makes good shovels and good ploughshares, but in automobiles it is less economical to the owner than to the maker, although it should perhaps be admitted that a capable designer may steer a moderately safe course, commercially speaking, between too much weight, on one side, and too short life, on the other, and yet use nothing but ordinary carbon steel.

In order to produce the greatest value, however, it is the low-carbon alloy steel which affords the most suitable, and, in the long run, the most economical construction material from which to build automobiles for severe service, just as it has already been abundantly proved to be the highly specialized alloy steel of high carbon, which affords the most economical material for tools for all purposes requiring hard work and long life. There is still left a large field for simple low-carbon steel in the construction of cheap automobiles intended only for very light work and low speed. But the field for simple high-carbon steel lies in other spheres with which the purchaser of automobiles, as such, has little to do.

While convinced that a clipping bureau or advertising agency, rather than Mr. Eames, is responsible for the press notices which have been so widely copied and in which simple high-carbon steel is recommended as construction material for automobiles, I would suggest that a public discussion of the subject would be timely, and to this end I propose the following theses:

1. There are alloy steels, of 10 to 30-point carbon, offering very nearly the same facilities for forge work and surface-hardening as ordinary steels of same carbon contents.

2. These alloy steels, referred to under 1, are not only superior to ordinary low-carbon steel in strength and durability, but are proven stronger than ordinary 50-point carbon steel by all static tests, and much tougher and more durable than ordinary 50-point carbon steel by all dynamic and shock tests.

3. The only point of superiority of simple 50-point carbon steel (whether basic open hearth, acid open hearth or crucible) over the low-carbon alloy steels referred to, lies in its lower price.

4. Alloy steels should not be used to reduce the weight, but to increase the durability of automobiles.

New York City.

MARIUS C. KRARUP.

### AN EFFECTIVE WAY OF LOCKING A CAR.

Editor THE AUTOMOBILE:

[1,360].—There are many reports from various cities of automobiles being stolen while standing unattended, particularly in the evening; and it struck me that there should be some simple method of locking a machine, beyond the general custom of taking away the switch key. I worked out a little device on my own machine and which I offer to your readers for what it is worth.

My clutch pedal when thrown out comes to within about six inches of the dashboard. I have therefore attached to the dash where it joins the floor a good solid plate staple through which I run a chain around the clutch pedal, bringing the two ends of the chain together and lock them with a brass padlock, and with this device attached and my emergency brake on I defy anyone to make off with my car. The device is so simple and the total cost runs under \$1.50, so that it seems to me a pretty good "insurance."  
Detroit, Mich.

S. C. STEARNS.

### COOL RUNNING WITH THE FAN BELT OFF.

Editor THE AUTOMOBILE:

[1,361].—Some time ago I had occasion to go to a house a few miles out in the country. When I arrived I noticed the water boiling furiously in the radiator. On looking inside, I found the belt which drives the fan had broken and was lost on the roadside somewhere. As the weather was clear, the roads not dusty, I took off the hood entirely and ran home without the use of the fan. The water never boiled and the engine as cool as ever. This may be a trifling item to report and it may have been done hundreds of times before, but it is often these little almost self-evident things which we forget to mention.

Richmond, Va.

M. D. HOGE, JR., M.D.

### EXPLAINING THE MAXWELL OWNER'S TROUBLE.

Editor THE AUTOMOBILE:

[1,362].—In reply to letter No. 1,320, would say the Maxwell oiler is of the compression type. After the car is stopped the oil will feed as long as there is compression left in the crankcase. As the pistons generally stop farthest from compression and the rings become worn, quite a quantity of oil will find its way into the firing chamber. And this makes the motor start irregularly and smoke until the cylinder can clear itself through the exhaust. Try loosening the screw cap at the top of oiler when you stop the car.

Hightstown, N. J.

R. W. NORTON.

### HELP FROM A SOUTHERNER FOR MR. RADWAY.

Editor THE AUTOMOBILE:

[1,363].—In reply to Charles J. Radway, in your issue of April 23, letter No. 1,320, would say he will find his trouble in the valve seat on the stem of his float, either from a sprung stem or a bad seat. When the motor is stopped, it lets too much gasoline in the carbureter. If he will see that the float valve shuts off all right his motor will start and not miss with the spark retarded.

Greenville, S. C.

FRED H. COOPER.

### HOW THE INQUIRER MAY REMEDY TROUBLE.

Editor THE AUTOMOBILE:

[1,364].—Seeing in "The Automobile," issue of April 23, a Maxwell touring car owner having trouble when starting, will say that a Schebler carbureter will fix this, and if this does not, a new exhaust valve spring will. He will also find a stiff wire brush (sold by the Maxwell people), to clean his cylinders out, a great help. This fixed our Maxwells.

Berthoud, Col.

BERTHOUD AUTO COMPANY.

### SUGGESTIONS FOR A PUZZLED AUTOIST.

Editor THE AUTOMOBILE:

[1,365].—In answer to letter No. 1,320, in your issue of April 23, I have a Maxwell two-cylinder touring car and experienced much the same trouble. Think he will find the cam and contact blocks of his commutator worn, or the spring weak. It would be well for him to examine them.

Carroll, Ia.

E. N. MERCHANT.

## FARMER, ACCUSTOMED TO MACHINERY, CAN "USE" AUTO

FROM THE NATIONAL GRANGE OFFICIAL ORGAN PATRONS OF HUSBANDRY—N. J. BACHELDER, EDITOR-IN-CHIEF.

A FEW years ago a very strong feeling prevailed in the rural districts against the automobile. This was due to the fact that farm horses were not accustomed to the so-called "go-devils," and accidents were by no means uncommon. For a time there was an effort to create a sentiment against the automobile so as to legislate it out of existence, but that feeling has almost entirely passed away. Concessions made on the part of automobile owners and the exercise of a greater degree of tolerance on the part of farmers have amicably solved the whole difficulty, the result being that the automobile among all classes is more popular to-day than ever. With the increase in the number of machines used driving horses have become more accustomed to them and accidents to-day are few and far between.

We are acquainted with a few farmers who own an automobile, and we find that these machines are more highly prized by those who make use of them on the farm than they are by the city man. As the farmer is accustomed to handle machinery, he is able to "use" and not "abuse" his machine, and as he is his own machinist, he keeps it from getting out of "kilter" by always having it in the best of running order. He knows that

it is not the wear and tear during use that is hard on farm machinery, but the lack of care, and, fortified by this knowledge, he can get much greater service out of an automobile than can the average man who possesses no ability as a mechanic.

Horse feed in these times comes high, and the horse eats whether he works or not; the automobile, while it is standing still, costs nothing to maintain. A twenty or twenty-five-mile journey is a day's work for the average team, while with the automobile this distance is covered in about an hour. As the King road drag comes into more general use, the automobile will increase in popularity, in our opinion, because it satisfies a real need on the farm. It is not necessary for us to enumerate the uses to which it can be put, as each farmer knows full well how often he can use a good driving horse or a good team if these are available, and when you consider that the time of a horse can be cut in two, and even better than that, the conclusion must be reached that the automobile will be of the greatest service to humanity when it becomes the distance annihilator for the farmer, as it now is for the large body of automobilists who recognize its value for getting over the ground quickly.

## PHYSICIANS TELL OF THEIR GREAT USE OF AUTOMOBILES

AS a class, the automobile has no more consistent and more loyal set of users than the medical fraternity. First and foremost, the doctor invests in an automobile for business use; it will take him where he wants to go—where he is needed, often very urgently—in a fraction of the time any other method of transportation at his command can possibly do. It will take him long distances in a very short time, and robs the country practise of much of the hardship attendant upon long drives in bad weather and at all hours of the night. It is no less valuable or less useful to the medico whose practise lies within the confines of a city. So that it is scarcely to be wondered at that doctors comprise a very large portion of the total number of auto users. Likewise, doctors form a very substantial fraction of the buyers of Rambler cars, and, on this account, Thomas B. Jeffery & Company, Kenosha, Wis., have made the May issue of the *Rambler Magazine* a special physicians' number.

It is a thirty-six-page booklet, gotten up in an attractive typographical dress, and is replete with attractive photographs of the doctors and their Ramblers all over the country. It is not alone one of the most pretentious efforts of the kind ever produced by the publicity department of any automobile manufacturer, but it is also the biggest thing of its order ever attempted, as an edition of no less than 50,000 copies has been printed, so that one will be placed in the hands of every doctor from Maine to California. In addition to the very numerous photographs of doctors and their machines, which serve to illustrate this special issue of the *Rambler Magazine*, there are a number of interesting articles contributed by physicians, showing how the ownership of an automobile is something without which the modern doctor is badly handicapped.

But it is not all business by any means, for the doctors, as well as other people who buy cars, do so for the double purpose of getting round where they are wanted and of giving enjoyment to their families of a nature that only the automobile can provide. So the wielders of the knife and the administrators of pills and lotions are also shown in their hours of ease, toward which their cars contribute so greatly, as well as on duty bent. Nor are they all Ramblers of the latest vintage that the makers have pictured in the pages of this unusually attractive issue of the magazine, as some of them date back to the earliest days. For instance: "I have worked my car hard since 1903," says

Dr. R. M. Tafel, of Phoenix, Ariz., "and feel as kindly toward it as I do to the family horse. I bought my car for work, and not for pleasure, and am glad to say that the repairs on it have been trifling."

"Four years without repairs," says Dr. J. C. Carson, of Valparaiso, Ind. "My practise has grown greatly since I got it, and after having made 15,000 miles, my first Rambler was sold on its reputation for only \$300 less than what it cost originally." This is the general tenor of the experiences outlined in the magazine, though some go into detail to a greater extent, showing that even without considering the vastly greater service rendered, the automobile is a better investment for the doctor than a horse.

Says Dr. A. H. Robinson, of Kenosha, Wis., on this point: "Two years' experience with a Rambler in my practise, after eighteen years' experience with a horse, has convinced me that I can do double the amount of work with an automobile and yet have more time for recreation." This, in fact, sounds the keynote of the value of the automobile to the physician, as it prevents him from being bound down to his work for eighteen to twenty hours a day. Continuing, Dr. Robinson says: "After eighteen years' of faithful service, I do not wish my old horse to fall into unkind hands, but if he were to die I would never buy another, but would use two automobiles. I have never had an accident with the Rambler, and have never been towed in, and the car has always gone on its own power, although the first thing I did with my car was to make a 2,000-mile trip. I expect it to run as well for two seasons more."

Doubtless the class of information that physicians who are intending purchasers of automobiles are most anxious to gain is that concerning the actual cost of keeping and running a car. This subject is pretty well covered, as may be seen from the following taken from the contribution of Dr. Alexander Nettelroth, Louisville, Ky: "I have calculated my mileage from figures based on the first 5,280 miles (then the odometer was broken and not replaced). I used 241 gallons of gasoline; this gives an average of 22 miles to the gallon, and has since been verified over known distances and is accurate; hence, I can fairly estimate my mileage on a total of 800 gallons consumed to the first of this year as about 17,600, which cost me \$746.73 over a period of five years. An accident contributed a heavy repair item to this bill, there being no expense for repairs in the fifth year."

## A STUDY OF THE MICHIGAN FACTORY SYSTEMS

By BERNE NADALL.

**D**ETROIT, May 11.—With an ample equipment of modern machine tools, a good many of them of special design, 2,000 skilled mechanics, housed in a spacious, well-ventilated and light factory of hygienic construction, and an organization of unusual merit, the Packard company of Detroit stands foremost as one of America's leading scientific institutions. Everybody knows the Packard car, so we will deal mostly with the concern that makes it.

To know of the workings of the organization is to gain knowledge as to how well the work is done. The first impression of the plant was gained by the handsome entrance and a stroll through the spacious hall which leads to the various offices. The arrangement of these is in itself a study, as each office has outside light. This scheme is applied throughout the works and naturally all hands are working under the best conditions at all times, both socially and hygienically. An illustration of the correspondence room shows a busy force employed. No office

tracings are cared for in the same manner that the banker safeguards his money and the most precious of his documents. They are as carefully guarded against loss by theft or fire as the most valuable papers possibly could be, and a most complete record is kept of every one, showing exactly where it can be found without a moment's delay.

Going into the factory one finds a clean shop. By clean is meant such cleanliness as one would find in an office. The whole institution is one of newness and comfort—even the wood working department is free from dust or grime, and also that awful clatter which usually attends a visit to a wood-working plant. It is impossible to show a view of this and several other departments, for some of them never have been photographed. It would be well worth showing the wood-working department as an example of what can be done in a factory by way of benefiting the conditions of the men. The new engine house also is incomplete, but of equally fine proportions.

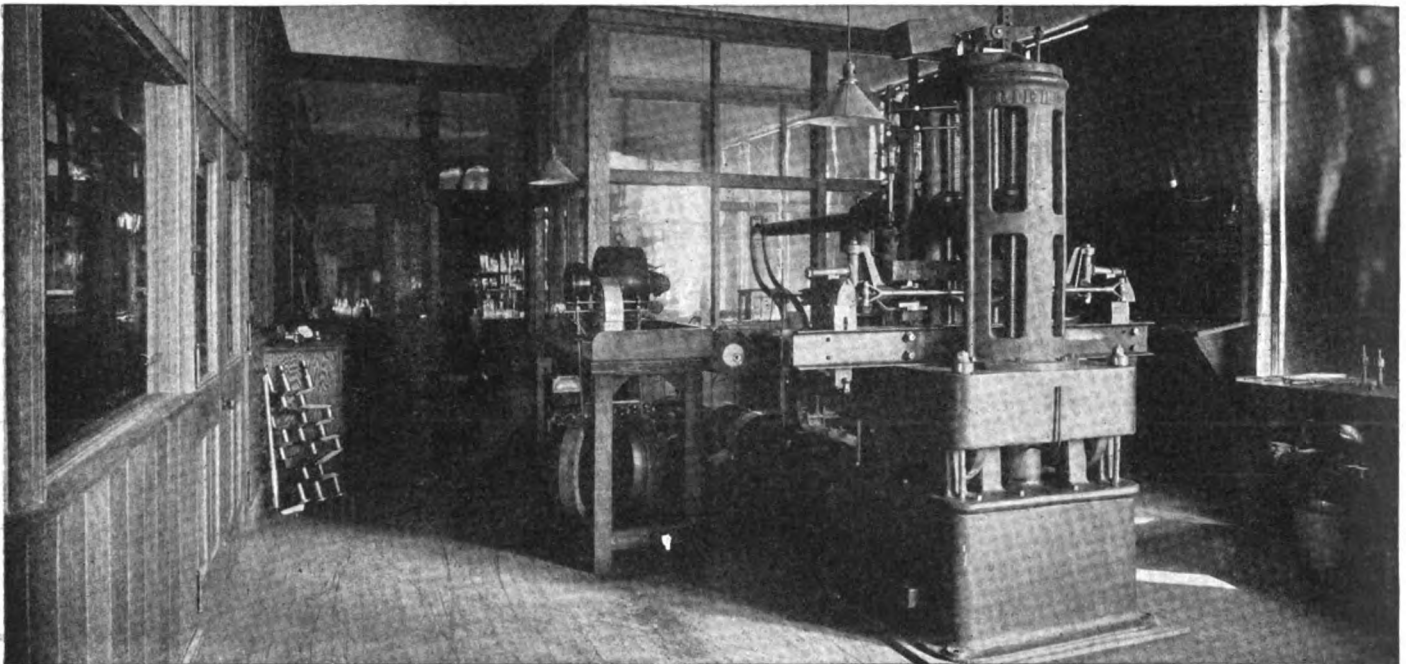

A Glimpse of One Corner of the Completely Equipped Testing Room of the Packard Plant.

contains a stenographer and no typewriter mars the quietude of the various official sanctums, which is an innovation that must be tried to be appreciated. No better summing up of the situation can be made than is illustrated by this trend, shown all through the institution—the minute study of every part and every condition. In an illustration of the physical laboratory, which is in line with the row of offices, but just as quiet a place to be in, it will be observed that a spring is shown undergoing a test. No part of the Packard car leaves the works without first passing some official inspection; by that is meant that every part must be recorded and hall-marked by the proper official, who does nothing else.

Next to this department is the chemical laboratory, where experts are continually analyzing the ingredients which go to make up the metal formulas, or to test such products as the company might purchase from other concerns or countries, as no new invention which is of interest to the motoring world is ever turned down by the company without at least an investigation as to its merits. The draughting department is as large as the stenographic staff; in fact the photograph herewith shows only about one-half the staff at work. Original drawings and

Of the many departments which go to make up this huge concern, the visitor is impressed by the scrap department, which occupies the large space of 5 square feet. It was with pride that the guide showed the scrap pile. One would think, because of the great amount of testing going on, that a big scrap pile would accumulate, but it is said to be quite the reverse. The fact that everything must pass a certain test makes the men exceedingly careful, and by keeping each man up to the mark he makes a better workman; in fact he always is improving rather than retrograding. This goes to show that quality need not necessarily mean waste.

On and on through the spacious buildings we went—a never-ending, instructive trip. At one point incomplete engines galore were found, running with dummy cylinders; at another the engines were running under their own power. A continuous chain of systematic shifting always was taking place as the work progressed, and not one moment was lost in the operation. It was particularly interesting to note the manner of checking the work as it went through the factory. A tally card is attached to every job that goes through. These cards are numbered and recorded and at any time one can trace where the job is. By



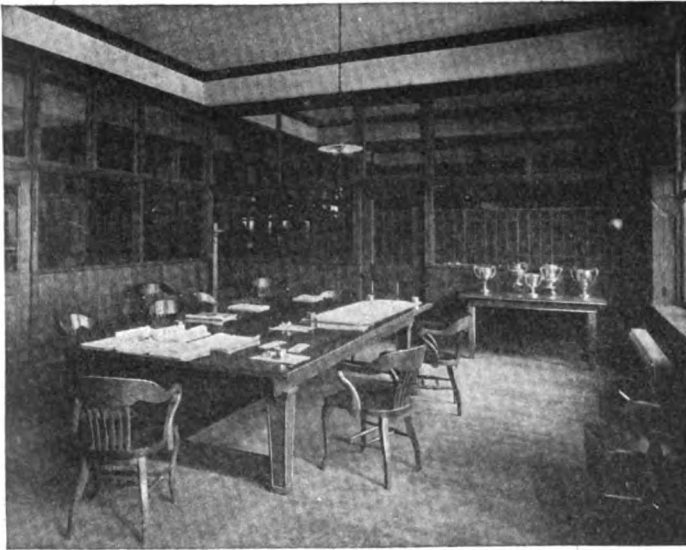

The Packard Visitors' Reception Room.

the time the card leaves the machine shop it has a whole motor car attached to it, but even then its course is a long way from the end. Each department through which it goes records the work done and also checks off by punch mark every article that has been supplied to it by the other departments.

#### Where and How the Rapid Is Built.

A visit to Pontiac, Mich., takes one to another concern which has made an exhaustive study of system in the shop. The Rapid truck is well known in many countries. Up to the present time no fewer than sixteen countries are using these commercial and sight-seeing cars, and the business is increasing all the time. Much of the success of this company is due to the manner in which the business is handled, both commercially and in the factory. It is not altogether plain to the outsider that it is more essential to have a good working system in the factory where commercial rigs are manufactured than in the pleasure car shop, but a little reflection brings to one's mind that a few days' delay in the delivery of a car or even a part in the case of the pleasure vehicle may not matter, but a 24-hour delay in the delivery of a part for a commercial truck will cause a running fire of complaint. Let one truck doing duty for a concern cease working for a day only and the condemnation knows no end; hence the manufacturer who wishes to keep in business must have his institution running in chain fashion all the time. The

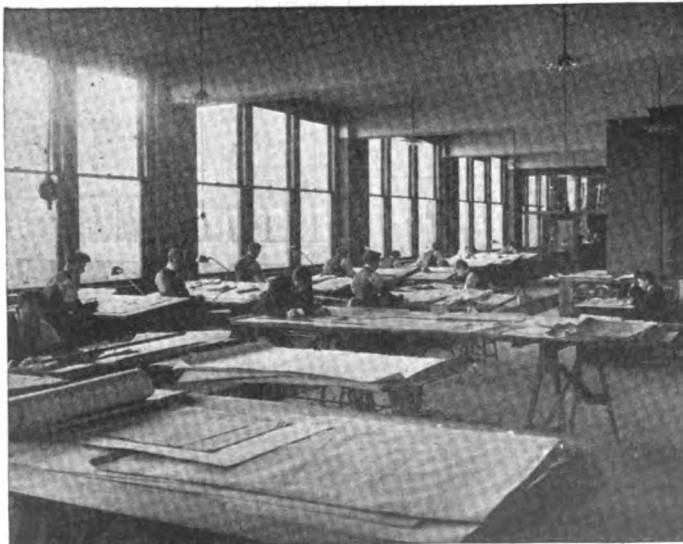

Part of the Packard Well Lighted Draughting Room.

Rapid people seem to have mastered the case well, and it is the only place visited where two store rooms are utilized to keep abreast of the wants of both the factory and the user. Every want received by mail or wire is on its way to the customer within an hour's time after the receipt of the requisition. The same painstaking care exists throughout the shop, and such allotments for work going through as may be required are anticipated by records of the progress of the work, and the material is found in readiness, waiting for the order of the shop foreman.

This system of working not only saves delay in supplying wants rapidly, but also assists in the purchase of new to replace depleted material. The two-store idea certainly is a good one, one being used for raw material and the other for finished parts. In each crib is a card which can be seen at any time, which shows just what has been taken and what time the replenishing order went through. When the new material comes in it is likewise noted and with a regularity that spells systematic application of good shop practice. Two sizes of chassis are turned out by this company, and there never is any confusion of orders, it is said, and no instance has been recorded where there has been a mix-up of orders. Besides the two sizes of chassis there are some four or five models or patterns of bodies fitted, making the work somewhat complex when it is known that sometimes 500 cars are put through at a time or within a season of a few months. In a shop where a good system was an unknown quantity such a proceeding would be impossible and chaos would reign.

To give one an idea of what a factory must stand in the way of bad treatment of cars it is said that while the largest Rapid truck was rated to carry 1 1-2 tons, it frequently was found that as much as 3 tons were carried regularly. Not only are the trucks overloaded, but when in the hands of careless drivers speed is unnecessarily fast. Such a thing as nursing an engine, which is already strained by overload, is seldom done, the reverse being the case nine times out of ten. Thus it will be seen how well it must be made to stand everyday usage under present conditions. As time wears on, naturally things will shape themselves and the truck user will learn that a good motor truck always has been a far better proposition than he supposed it to be. In the Rapid chrome nickel steel enters into the construction. An illustration of the Rapid chassis, onto which are built hotel buses, police patrols, ambulances, wagonettes, sight-seeing cars and trucks of every design, appears.

In the chassis illustration will be seen the spring suspension which is somewhat novel. The platform pattern is adhered to but supplementary springs are used as well, being placed over the axle in the case of the rear one and under the seat position in front. In each case these supplementary springs are placed crosswise and alleviate any listing that would occur from overloading at one or the other side without the supplementary springs.

Each piece or screw of this chassis has a number, name and code word by which it may be ordered, which helps to make the perfect system referred to above. Also illustrated is the jackshaft construction, which is good. Usually a jackshaft on a truck is a more or less neglected part—a sort of go-between which becomes neglected in the same manner as the chains, finally giving trouble. The Rapid jackshaft is a nice piece of work and is in keeping with the rest of the car. Timken bearings are set in the ends of the seamless steel tubing, all of which is supported and aligned with a perfectly braced sprocket.

The same inspection is given to such parts as is received by the engines or other more important essentials. Another novel point is the manner in which the valves are set, being both air and water-cooled. The illustration shows a sectional view of the valve pocket, the part A being the point where the valve seats and B the stem groove, the design forming a simple water-air surrounded arrangement and accessible. Part C shows how the valve can be taken out. The valves are mechanical and the intake port permits the gas to enter and be drawn in to the cylinder without a great amount of vacuum or eddies. The manner of taking the valve casing out is also good, the illustration

showing the two pieces, the inner piece, when released, sliding out in a manner similar to the French pocketed valves, which usually are fitted into the head of the vertical four-cylinder engines.

**Pointers in the Design of the Oakland.**

Among the new cars of the last year or so may be named the Oakland, another of the products of the busy brain of Alanson Brush of Cadillac fame. This car, like others which have been designed by Brush, is full of novelties. The engine particularly is interesting. In the first case it is a two-cylinder vertical motor of the usual French type. The Oakland motor, besides being a two-cylinder vertical engine, also is a vibrationless two-cylinder affair. When the two-cylinder vertical idea is broached to an engineer in this country he at once nails your argument by the claim that the two-cylinder horizontal is better.

In the Oakland product there is a set of balance weights theoretically worked out in a manner to produce a compensating action for both the vibration and the explosion torque. The means of procuring this is novel in the fact that it is simple and adds but little extra expense for the increased advantages. In the illustration a view of the complete engine is shown with explanation of each part. By noting this closely it will be seen that gearing is the means of accomplishing the action of the counter weights, A and B, by the revolutions of the engine shaft. To the left will be seen the driving mechanism of the valves and to the right is shown the ball-bearing balance weights, A and B. These weights are placed on an eccentric shaft to procure variations in setting, as it is very essential to get the compensating balance weights perfectly adjusted in the beginning. It will be observed that the crankshaft weight can balance only one thing and that is explosion torque, the vibration occurring presumably immediately after the explosion. If this is the case—and we know that the vibration of a vertical internal combustion engine is in a lateral direction—then there are times in the revolution of the crank that the weights are accomplishing little; that is, at one moment they produce a great resisting element and gradually cease to have retarding action the further the crank turns away from the point where the explosion occurs. Naturally, these weights are revolved by the turning of the crankshaft, to which are attached the usual balance weights, designed in this case, however, with special reference to the action of the counterbalancing device, which is what serves to make the Oakland motor one of the quietest running of its type.

Now this fact is apparent in all two-cylinder vertical mo-

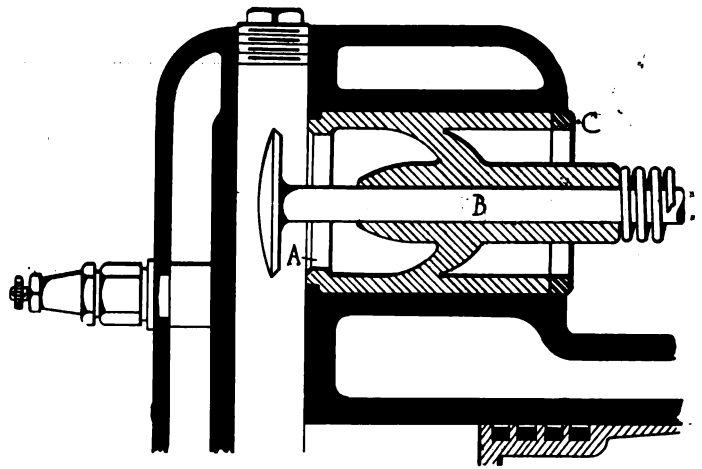

**Design of the Valve Pocket of the Rapid.**

tors and would be observed in the Oakland but for the counterweights, A and B, which come into action when they are wanted; namely, when the vibration sets in. It is plain that a large percentage of the vibration of the two-cylinder verticle engine has been done away with. One demonstration which was made was that of placing a lead pencil, point upwards, on the top of the cylinder and running the engine at something under 500 revolutions per minute without vibrating the pencil off the cylinder.

Another point is the apparent extra power shown. While the horsepower formula, such as adopted by the A. L. A. M., would show 8 horsepower—the two-cylinders producing 16 horsepower—it is a fact that the Oakland engine seemed to do better work on the road. There seems to be greater activity under all conditions than on any similar car; the pick-up is very noticeable, and with the engine running low the acceleration is quick on hills, considering the load that was being pulled. It appeared that reducing the vibration brought about a freer engine action.

The transmission is another novel feature. It has two speeds forward and one reverse, and is attached to the driveshaft under the front seat. It is a planetary gearset, but instead of brake bands it has clutches which run in oil carried in the aluminum case. The claim made is that in the ordinary planetary there is always a drag which is entirely overcome by this new clutch principle. The illustration shows the design of the casing E:

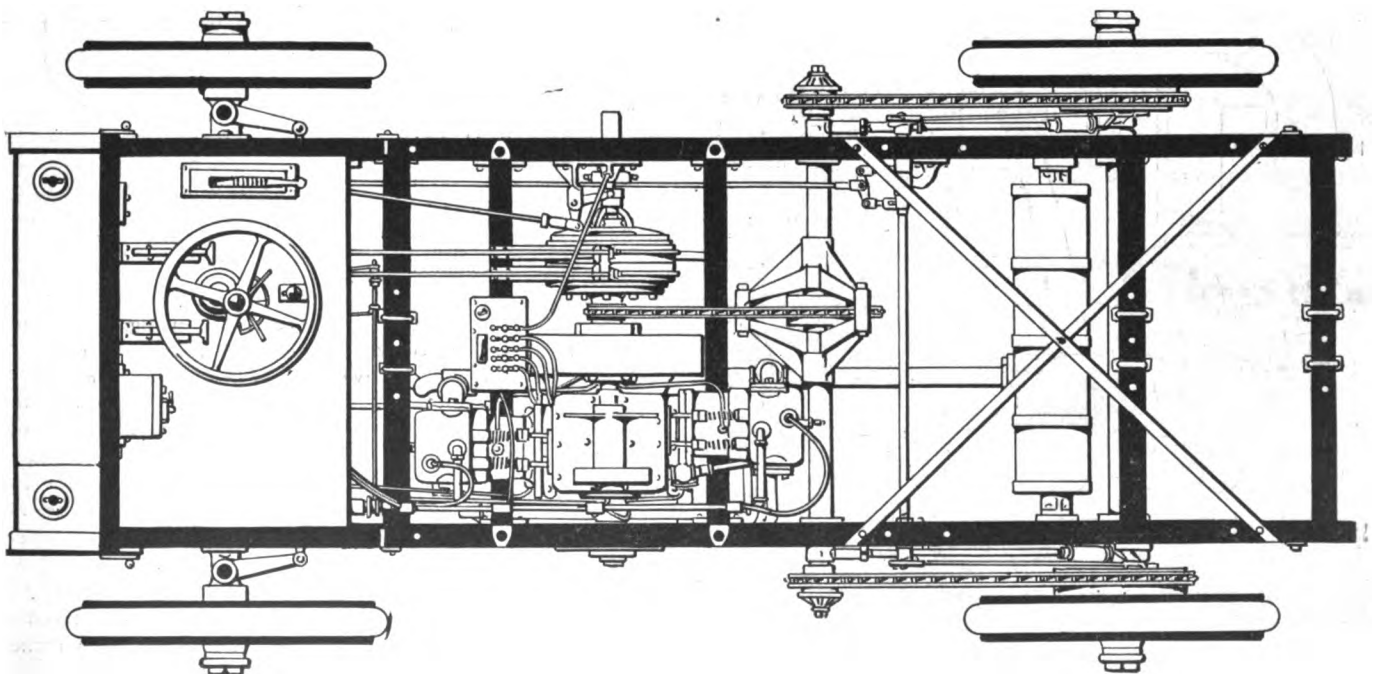

**Plan View of the Two-cylinder Horizontal Engine Rapid Commercial Chassis.**

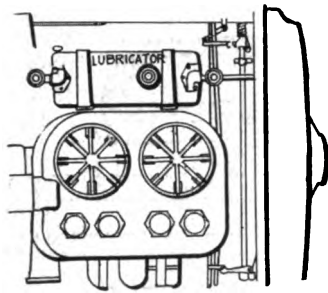

Plan View of the Oakland Motor.

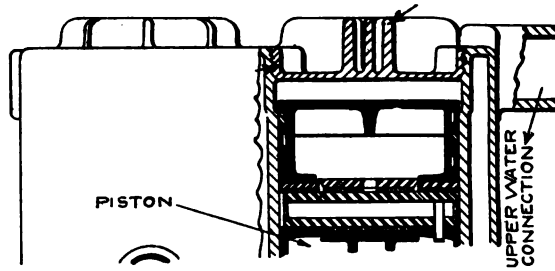

Part Section View Showing Cooling Flanges.

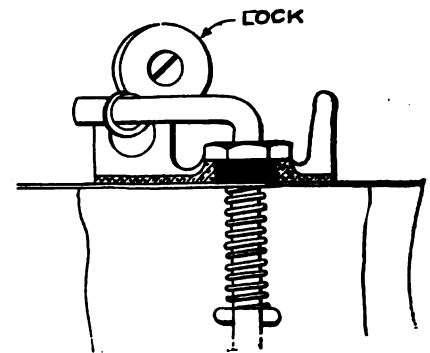

Oakland Gasoline Tank Lock.

with one side cut away. The part A is the clutch ring shifting arm, that marked B the high speed clutch lever shaft, and C is the slow and reverse clutch ring. The high speed clutch D is a multiple-disc affair and is self-locking, the speed being thrown in by the side lever and separate from the others. The low speed and reverse are manipulated by the pedal, and the ease with which these clutches are worked is certainly gratifying. The clutches work longitudinally and are cone-shaped. F are the planetary gears, G thrust bearings and H a universal.

Oakland features are all Brush, and that means that there always is more than one way to do anything. As in the case of the Brush car the head of the cylinders is fitted with a most accessible cap of a diameter larger than that of the piston and set in by a coarse thread which insures it being gas-tight as well as easily removed. An illustration shows this cap, A, and also the valve cap which is beside it. The cooling of the cylinder head cap is procured by fins, F, cast into it. The water-jacketing of the cylinders is well designed and made to take in the full stroke of the piston. The oiling system also has some unique points in that oil grooves are used to deliver the oil to the proper places and in the case of the transmission an outside lead is fitted to the tank which leads to the transmission casing. The lubricator is set close to the cylinders to insure proper feeding in cold weather. On the gasoline tank is fitted a lock which prevents any tampering with the car in garages and such places, a commendable arrangement. It is these little refinements which the autoist appreciates in these days of the successful car. It is

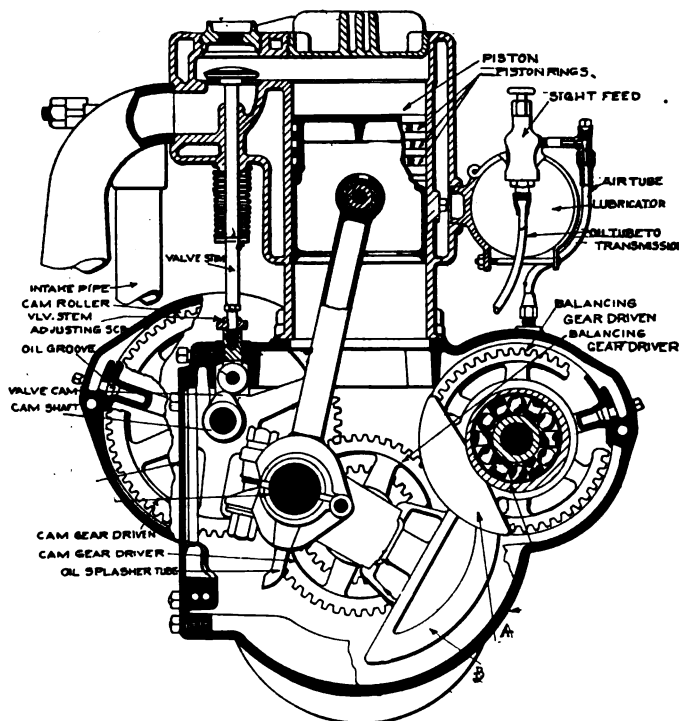

Sectional Elevation of the Oakland Motor.

said that a big market is expected in the near future in the taxicab line for this little car—a use for which it is admirably suited. Maximum economy of maintenance in constant service of the strenuous order called for by this usage is claimed by the makers, and when the car and its possibilities are better known, it is expected these claims will be found to be amply borne out.

**Ford Has a Great Deal Up His Sleeve.**

Calling at the Ford plant the writer found numerous new ideas being worked up, but as Mr. Ford was not as yet ready to have anything published the Ford secrets remained secrets. However it was noted that at this place there was no sign of a slump. The very morning the writer arrived, at 10:30, orders to the number of seventy-three had already been received for the little runabouts. On the second morning he was told also of an order for 100 cars arriving from England. Three-point suspension still reigns supreme here, and some of the new machinery which the company has been installing the past winter was shown. It was apparent that a great amount of money was being spent by this concern and that it now is a fact that vanadium steel is entering into the construction of Ford models—old and new—to a very great extent. Eight ovens were already placed for heat-treated vanadium and four large hammers were available for quick working. Most of the new machinery was especially designed, and the designs are the sole property of the Ford company. From the appearance of the place it was evident that the Ford was soon to spring another sensation on the public, but just when that will be, probably only Henry Ford himself knows, and that means there will be nothing known about it until Mr. Ford is good and ready, which will be when everything is ripe and not before, for it has always been a Ford plan not to make any public announcements until everything was in readiness to back them up. No one who has not visited a representative automobile factory can conceive of the amount of preparatory work that is involved in placing a new model on the market, where it is to be turned out in numbers.

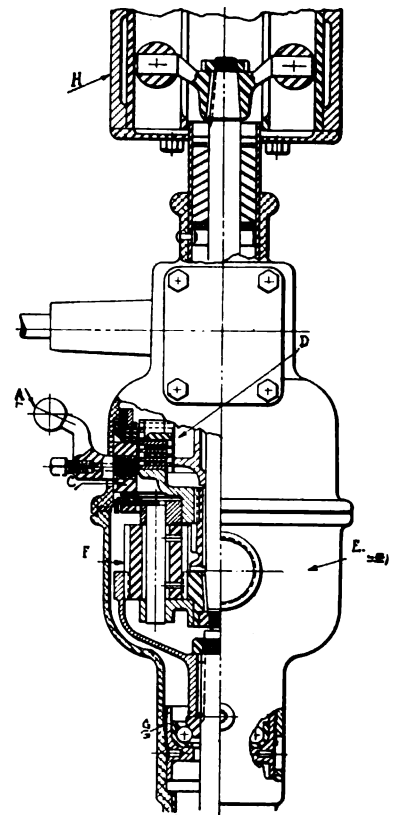

Oakland Planetary Gear Set.



# How a Big Red Car Linked the East with the West

By Roger W. Power



THIS story is the record of a transcontinental trip in which a 40-horsepower Glide figured as the hero and five passengers, including one member of the fair sex, laid up a store of pleasure, the memory of which will be carried along to a very distant future. Palmyra, N. Y., to Salt Lake City, Utah, does not include the entire distance across the breadth of the United States, and, technically, we are excluded from the ranks of the transcontinentalists, for we did not see either ocean; but there was a prelude which must be added to our record in the form of a run from Peoria, Ill., to Mormon Hill, in the northern part of New York State, where Joseph Smith, the founder of Mormonism, is said to have dug up the "Golden Plates."

We were fully loaded up for a 5,000-mile tour when we pulled away from the National Hotel, Peoria, Ill., our united weight, with passengers, trunk, four grips, and extra tool box, tipping 4,350 pounds. A bolt sheared off one of the front springs before we had passed out of the State. We discovered it while lunching under a delightful canopy of green, finished our meal in true picnic style, pushed on to Fairbury, and had the defective piece of metal replaced at a cost of five cents. This proved to be the only outlay we had to make for repairs on the entire journey. We ran out of gasoline when three miles from town, strayed from the right road when near the border line, and had to suffer axle deep mud as a consequence, and finally were responsible for the death of one of Michigan's big white roosters. But as it was impossible to shift the responsibility for any of these adventures, we were well satisfied with the way in which our Glide had carried us to the deck of the Eastern States, bound from Detroit to Buffalo.

## All Well Aboard, Bound for Far West.

A brief visit to Mormon Hill and other points of interest, and at high noon on August 2 we "gasolined" out of Palmyra, N. Y., for the far West, all well on board. Batavia housed us that night, and Buffalo and the Falls had our company for the next twenty-four hours. Our first puncture came just after a stop at the Falls to have a tire vulcanized, and was caused by a thin wire nail pricking a hole through the casing. It required some navigating sense to get through Buffalo with its maze of cross cutting but as soon as the shore road was struck complications ceased and fine roads were our lot. Three hours out of Erie the expert was dissatisfied with the way in which the carbureter was attending to business and ordered a stop which proved to be of short duration and did not prevent us reaching Erie for dinner. Some of the hills west of Erie were sufficiently formidable to tackle the full power of the car and though the roads were good, we had to slip into the low gear and literally crawl to the top. Going down it was necessary to lock the brakes. After lunch at Conneaut, a pretty little town with a hotel that holds out a real welcome to automobilists, we replaced a tube on the right-hand rear wheel in exactly fifteen minutes. By 6 o'clock we were rolling over the smooth surface of Euclid avenue into Cleveland, and at nightfall were on board the *St. Ignace*, bound for Detroit.

The changes which we made in our western route to Peoria did not bring with them improved roads, the going through the picturesque country from Clinton to Coldwater

being so sandy that we had to drop into the intermediate gear and could not accomplish more than 107 miles for the day. To South Bend, Ind., the same

conditions continued, necessitating further use of the intermediate. We pushed ahead and reached Valparaiso that night.

Along the banks of the Kankakee river, near the border line of Indiana and Illinois, there is some magnificent scenery, the road leading for about three miles through a vast forest lying in a swamp formed by the overflow of the Kankakee. The path cut through the wood allows the passage of only one team at a time, so that we were compelled to hurry through, blowing our horn all the time. Here and there among the massive trees strung together with festoons of vines would be found an open spot where the water would be lower and a small island of green would be formed. All this, mingled with the song of the birds, made it a spot at which we would gladly have lingered.

After bad roads from Effner to Watseka, Ill., where we passed the night, we pulled out, and at Gilman picked up the trail of a Thomas Flyer, which we followed to Forrest, obtaining a better road than the one we had going east. Running between Chenoa and El Paso, a big farm team loaded with people going to church came towards us. When almost opposite, the two horses shied, there was a mix-up which resulted in a broken strap and gave a slight scare to the ladies of the party. The payment of \$1.50 made everybody happy, and we proceeded on our way, only to be stopped a little later by a puncture, which we righted on the schedule time of fifteen minutes. When we ran into Peoria again our total expenditure for repairs, excluding the compensation for broken strap, was five cents.

## Starting Out for Adventures in the West.

After the car had been looked over at the factory, we proceeded westward in a cloud of dust caused by a big six-cylinder ahead of us. We stood it for half an hour, then dropped into the rear to get a little breath, putting on a spurt soon after and passing the six.

There was some real excitement late in the evening when running from Macomb to Carthage. The night was dark and the road a difficult one to follow, our only direction being to keep the main traveled road, and we "couldn't miss it." We thought we followed out the simple rule of conduct, but something must have been amiss, for we suddenly found ourselves in the farmer's back yard, where our brilliant headlights caused a terrible scare among the women folk. Either the farmer's powers of explanation were weak or our comprehension was dull, for after a long talk we had made so little progress that we asked the farmer to go with us, promising him a good automobile ride and a journey home on the cars. He thought it over for a while, then said he guessed he would do it and luckily for us he did, otherwise we would have had to camp out somewhere in the woods. When we pulled into Carthage it was 11 P.M., all of us dead tired and glad to turn in for the night. Before we got into Burlington, Ia., the next night, and covered 2,000 miles, we had a little trouble getting on the old river boat *Eloise*, which carried us across the Mississippi to a well-earned rest that all of us were mighty glad to avail ourselves of, as a day's drive makes one ready for bed.



As the real pioneer work was expected west of Omaha, Neb., we spent a day in that town making preparations. The commencement was good, for, although there were hills out of Omaha, the road was macadamized and paved with brick, so that we could bowl along in fine style without any interruption. After Fremont, we dropped into a lot of quicksand and only pulled out after throwing sunflowers and bits of boards under the wheels. After Schuyler, where an excellent hotel provided an excellent lunch, we struck a perfect, hard, level road which allowed a speed of 25 to 30 miles an hour, and enabled us to run up a total of 166 miles when we put into Grand Island for the night.



"An Indiana Auto"



A fishing party

Near  
Lima Ind.

Along the Kankakee

As we ran further into Nebraska the country changed, the little streams and the groups of green bushes, which were so plentiful in Iowa, giving way to a vast expanse of level and dry country as far as the eye could see, often decorated with golden sunflowers for miles and miles. Along the banks of the North Platte river as far as North Platte City the road was hard and smooth, reminding us forcibly of the Lake Shore drive along the south side of Lake Erie. Not until we had passed Sutherland did we get our first experience with a Nebraska sand-draw, causing long and wearisome labor, which might have been avoided by crossing the South Platte river at Paxton and taking the road on the opposite side.

At Julesburg, Col., we took a guide who showed us a way over the hills which gave a shorter and better route than the one by the railroad. At Chappel, Neb., our guide left us and we continued alone to Sidney, stayed there all night, and next day ran to Cheyenne, Wyo., over fine hilly roads.

#### Magnificent Automobiling on the Heights of the Rockies.

It was from Cheyenne that the real hill climbing began, our morning run to Laramie, only 67 miles away, giving us a climb of 8,100 feet to the top of Sherman Hill, the highest point in the Rocky mountains. It was a magnificent climb, over a roadway that is a boulevard of disintegrated granite, allowing us to skim along at a speed of 25 miles an hour for the entire distance. As if to crown the beauty of the ride, from the top of the hill by the side of Oakes Ames monument, a fascinating view is obtained which embraces mountain range upon mountain range, each rolling away in the distance like mighty billows of blue. With regret we left the spot and began to wind down through the canyons and gulches of the mountain side with never a bump or jar to mar the pleasure of gliding through the cool mountain air.

We considered it advisable at Laramie to enlist the ser-

vices of E. A. Buck, a civil engineer, to guide us through the little-known and often dangerous mountain wildernesses. On the Laramie plains some Denver tourists advised us not to attempt to reach Saratoga by the Rattle Snake Canyon route, a cloudburst having rendered the road impassable. Our guide concluded, although unfamiliar with the route, that it would be better to attempt to cross the divide by what is known as Pass Creek, and changed our line of march accordingly. A couple of large Packard cars, bound for the town of Hanna, followed us until they both became mired in a swamp which we had had the luck or the wisdom to avoid. Further on we had our difficulties in the shape of roads filled with rocks and furrowed to a depth of 18 to 20 inches, but they were all overcome by a responsive engine and enthusiastic workers.

By 3 o'clock in the afternoon we had reached the Medicine Bow Junction, crossed the river bearing the same name, turned south and wound round the side of the Elk mountain in Wyoming, to Pass Creek divide. After two hours' plodding the trail had faded away in the mountain grass, and we were compelled to turn back seven miles to a ranch house to

Across the  
Kankakee

A bad piece of road

Remains  
of a  
"Pony Express Station"

On top of Sherman Hill

learn where we were. It appeared that we had not been following the trail to Pass Creek at all, but that a road which turned sharp to the right at the ranch house was the right one. "It's a terribly rough road," vouchsafed our informant, which was not at all pleasant news for us, for on our seven-mile return journey we had had the misfortune to puncture our reserve gasoline tank and lose all fuel but that in the ordinary tank. Though it was 6 o'clock, we decided to push on, get over the divide, five miles away, pass down the other side, and reach Saratoga that night.

#### How Nature Was Victorious in an Unequal Struggle.

Darkness came upon us as we climbed up the almost impassable mountainside, and wound round chasms through which the water rushed hundreds of feet below. Finally, even a racing engine and the low gear were insufficient to the task, and we could only make progress by getting out and giving external aid. At 9 o'clock at night, high up in the darkness, with only the company of the quaking aspens, an examination was made of the road ahead and the resolution arrived at to abandon the attempt. We felt like deserters as we left the faithful car high up on the plateau, 9,000 feet above sea-level, and started to trudge the three and a half miles to

A Nebraska  
"Sand  
draw"

the rancher's house. We were received with a hospitality that is worthy of more than a mere passing mention. When Mr. Nelson, the rancher, learned that we had left our car up near the divide, he told us he owned a wild bull, who reigned supreme in that vicinity, and who would certainly destroy the red car if he and his family discovered it in the morning. In consequence our driver, Harry Russ, went back with the rancher and brought the car down the steep declivity, reaching the house at 2 o'clock in the morning. There were five pairs of staring eyes, and five busy tongues when the children came out next morning and found a big red automobile in their yard, the first that had ever been in their vicinity.

With three gallons of gasoline in our tank and no possibility of obtaining more, and the assurance of the rancher Steele, then across the Platte river as best we could. At that it was impossible to go down the Saratoga side of the hill, on account of the sharp turns, rocks and precipices that would be encountered, we felt, to use a colloquialism, "up against it." Our best plan appeared to go back to Fort Medicine Bow, but a man with a moving-picture show had forestalled us and taken every drop of gasoline the place possessed. But there was a telephone which enabled us to get Hanna for ten gallons to meet us on the road.

As we saw with our own eyes, the bridge over the North Platte had been swept away, the only means of crossing being by the railroad bridge. There being no alternative, we ran our car a mile down the track, rushed it up the embankment, and crossed the bridge 60 feet above the water, on the railroad ties. It was a thrilling experience, for behind us was a big, impatient freight train.

From Fort Steele to Rawlins, and from Rawlins over the Red Desert to Creston, there was not much fault to be found with the road. But when we began to climb down the grade to Bitter Creek and wound along by that famous stream, through its gullies and washouts, we discovered that the difficulties of the preceding days were but a prelude to greater trouble. With tire chains on and the engine devel-

oping its full power, it was impossible to get through the heavy sand without the use of the shovel. Two miles out of Hallville we had a puncture; two miles further on we had a blowout; half an hour later there was another blowout. So we were delayed, while Rock Springs, the only town which could offer any accommodation, appeared an interminable distance ahead. After numerous escapes from toppling off the washedout road into the creek, we finally reached the town, tired enough to hope that the next day would be easier.

P. W. Spaulding, an enthusiastic autoist and a lawyer, of Evanston, Wyo., met us at Green River and proposed to guide us to his home town. He reported that the Black Fork river was high, and that it would be dangerous to attempt to ford it, but believed that we could cross the railroad at Bryan, and by traveling to the north of Granger over an old trail, reach there without doubt that evening. We followed the old trail, but did not reach Granger. At 9 o'clock at night we were stopped by a gully about 50 feet deep with 18 inches of water and sand at the bottom, and with sides so steep that no vehicle could get down, or if it did, could not possibly get out again. There was nothing for it but to stay there all night. Some of us slept on the ground, or tried to, and others made themselves snug in the automobile. After a night spent listening to the coyotes and watching the rising of the moon, we were on foot with the first twitter of the birds, scouting about for a way to cross the gulch. None was to be found, so we returned to Bryan, loaded our automobile on a flatcar and ran across the Black Fork river, after which we unloaded, ran the car through Echo Canyon to Ogden, and then on to Salt Lake City and home.

Our journey had given us a record of 3,626 miles, over roads or no roads that sometimes necessitated the use of block and tackle, but never developed a defect or a weakness in the car. To-day it is running in as perfect condition as when it left the shop in Peoria, and has the honor of being the largest touring car which has ever crossed the Rocky Mountains on the overland trail.

## PLANNING FOR BIG MEXICAN ROAD RACE THIS FALL

MEXICO CITY, May 8.—According to J. L. Lawrence, who won the Jalisco cup last year on a 30-horsepower Pope-Hartford, plans are already under way for the holding of the race for the same trophy on a new course to be built at Guadalajara. The race was to have been held last month, but it has been postponed to November next, in order that complete preparations may be made. The work of preparing a racing circuit is in the hands of the Jalisco Automobile Club, and the plans already drawn up provide for a course that will be the best in the Republic for making fast time. It will be graded to an average width of 18 meters, while the curves will be widened and eased off so that better speed will be possible on the turns. Its length is to be increased from 35 to 40 kilometers, and, at the same time, the two railway grade crossings that were a dangerous feature of last year's course, will be eliminated. Numerous general changes in the course will also be made to improve it, and as the natural formation does away with the necessity of using any top dressing, a liberal grading and rolling will make as fine a surface as is to be found anywhere.

It is anticipated that the special committee of the club which has the Guadalajara meet in charge, will spread the program out to cover a week, which will be inaugurated by an endurance run, or touring-car race to Guadalajara from Mexico City. This is scheduled to start on November 5. Several touring car owners have announced their intention of entering for the trip, which will doubtless be a real endurance run, as there are all kinds of roads between here and Guadalajara. No trouble is expected in arranging a program of interesting events that will take up

the entire week, as practically every autoist in the republic will be there, and the attendance is expected to reach fully 10,000 people. There will be motor boat races on Lake Chapala.

Since receiving assurances that there will be no hitch in the arrangements for holding the Jalisco Cup race, there has been a noticeable revival of interest on the part of intending entrants. The Sanchez Juarez Company, of Mexico City, has announced that it will enter two machines, a 120-horsepower Spa and a Renault of the same power. The Compañia Mexicana de Vehiculos Electricos has stated its intention of entering a 60-horsepower Locomobile, a 90-horsepower Mercedes and a 120-horsepower Dietrich, beside which there will be a 90-horsepower Brasier, entered by Juan Cobo. J. L. Lawrence, the winner of last year's race, is slated to drive the Mercedes.

### Mexican Auto Club Has House Warming.

Elaborate preparations were made for the formal opening of the new clubhouse of the Automobile Club of Mexico on Thursday, April 23, and the event was a great success. The new building is beautifully situated in Chapultepec Park, on the bank of the lake, and is completely fitted up for the comfort of the members, as well as the accommodation of their cars, the garage being in a separate building at the rear. The club now numbers about eighty members, but there is now a long waiting list, and it is expected that many new recruits will be added in view of the club's move into its new headquarters. The officers are: President, Fernando Pimentel y Fagoaga; vice-president, Rafael Bernal; secretary, José Hilario Elguero; treasurer, Javier Algara.



The "Acme Gearless" in Readiness for the Push-off.

### YOUNG SAVANNAHANS HAVE "AUTO" RACES.

SAVANNAH, GA., May 9.—The youths of Savannah are certainly very much interested in automobile competition. Recently a series of pushmobile races were established, the first of which took place Saturday, April 25. There were 25 starters in the first event, Secretary A. W. Solomon, of the Savannah Automobile Club, sending them away on their ten-lap journey around the Confederate monument in Forsythe Park. The winner was Herbert Miller, whose three pushing mechanics apparently had more windpower than any other trio. Each contestant was allowed three mechanics or assistants, and it was a case of steering and pushing. The police patrolled the course, and while there were a few skinned knees and considerable torn clothing, there were no fatalities to mar the successful event.

For the May 2 race, J. E. Finney, the Acme agent, offered a handsome cup, to become the property of the driver who wins it three times. Edward Pacetti Jones, who raced under his foreign sounding intermediate title, and whose car bore the significant "No. 23," not only had the coveted honor of bearing away the Acme silver trophy, but received an enlarged photo of himself and his team of power plants, a baseball mit and \$3 in cash. No racing driver ever had half the glory that this winner of the southern "Vanderbilt junior" received when he was tossed on the shoulders of the crowd that cheered him. In the great race, which was the third event, the Jonesless driver brought "23" over the tape a full hundred feet ahead of No. 33, with Malone at the wheel, while McLeod, No. 20, came home third.

Nearly 60 machines were entered, and the send-off of the first race presented a confused maze of white streamers and goggles, lost beneath a wave of shouts that showed some of the motors to be wasting their windpower on other things than propulsion. "Prohibition" and "Red Devil" took the lead abreast and kept together for some time, but the devil won out in the end. According to one of the motors, "We do the work and

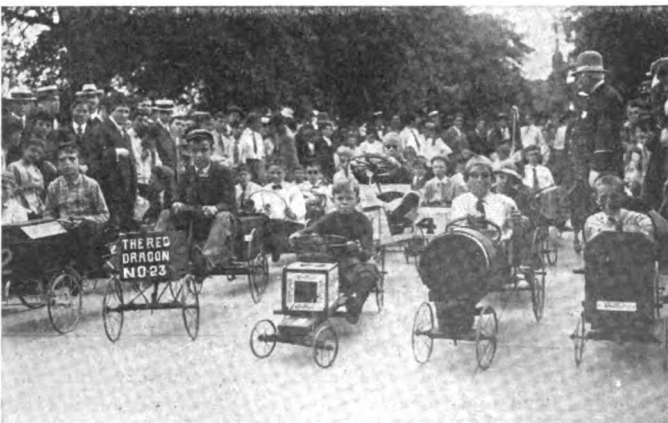

Line-up for the Hair Raising Contest—No. 23 Winner.

the driver just drives," but it took no little skill to pilot a car through the maze of fifty odd machines on a narrow course. "Death turn," just southwest of the monument, caused many a spill, and the daring driver who showed great skill there was christened the "big wiggie." The officials included Mayor Tiedeman and President Battey, of the automobile club.

Another race is scheduled for May 16, for which John E. Finney has donated a challenge cup, to be won three times before it becomes the property of victorious driver.

### SAVANNAH CHALLENGE CUP READY TO AWARD.

SAVANNAH, GA., May 9.—The Savannah Challenge trophy, won by Strang in the Isotta in March, has now been completed, and as soon as it can be suitably engraved, will be forwarded to New York, to be awarded to the winner. The accompanying photograph is the first that has been taken of the new trophy, and shows it to be a handsome specimen of the silver worker's art. The center panel, which dominates the decorative scheme, is



Handsome Savannah Challenge Cup Won by Strang.

occupied by a half-figure of General Ogelthorpe in high relief, while the ornaments are all suggestive of Georgia scenery, such as the palmetto, Spanish moss, and cotton. Round the nine-inch ebony base are plates representing cotton bales, designed to be engraved with inscriptions concerning the race, a new plate being used for this purpose each year. The cup stands twenty-seven inches high, and makes a most appropriate trophy.

### NEW YORK STATE HIGHWAY WORK.

Since 1898 the State of New York has completed 978 miles of improved highways at State, county and town expense. The State now has 1,034 miles of roads under contract and 977 miles of roads waiting the letting of contracts. In 1906, the State appropriated for highway improvement \$5,000,000. In 1907, \$3,000,000, and in 1908 \$3,000,000, making \$1,000,000 available now, and \$2,000,000 available in the fall. The appropriation, therefore, is as large this year as it was last, and it is expected that the increased amount of interest in the good roads movement will be responsible for pushing this work more than in former years.

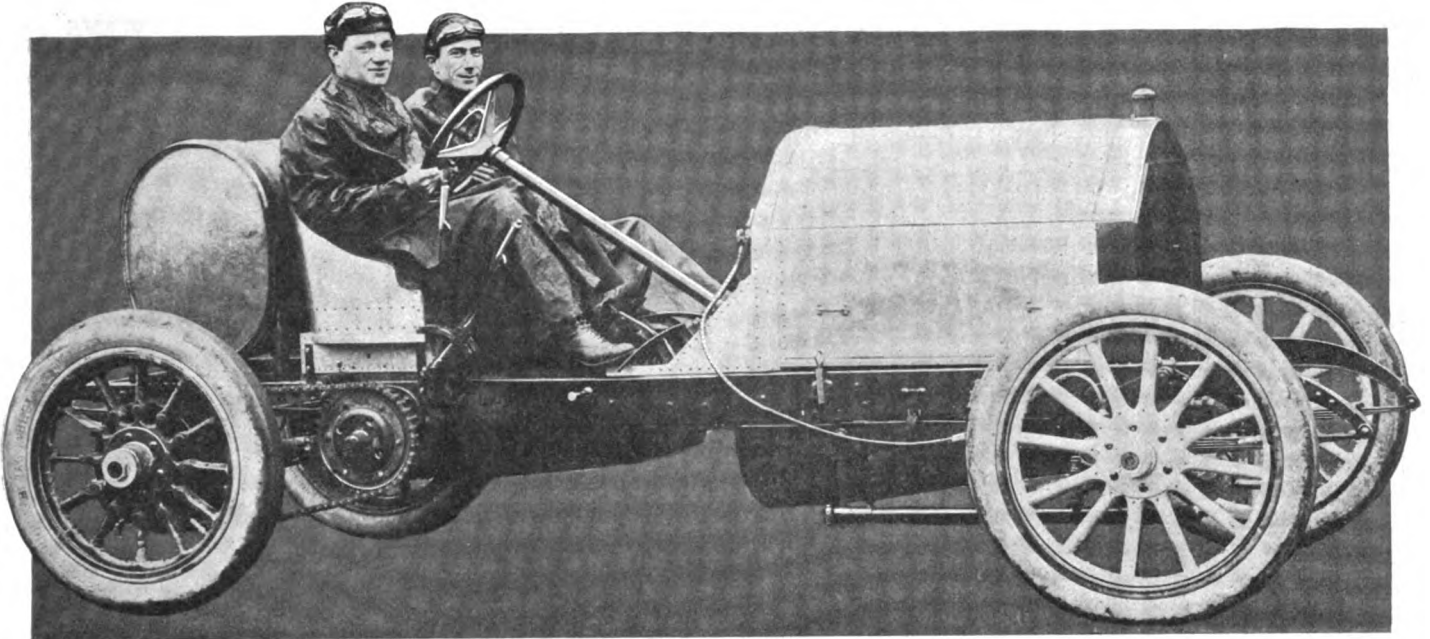

Thomas Flyer Which Has Been Slightly Changed by Increase of Bore for Grand Prix—Driver Strang and Mechanic Marquise Are Aboard.

## AMERICA'S CANDIDATE FOR FRANCE'S GRAND PRIX

**M**AY 20 a Thomas Flyer will be shipped abroad for a try at the Grand Prix, the blue ribbon of European automobile racing, scheduled to take place over the Dieppe circuit on July 8. Louis Strang, with John B. Marquise as his mechanic, will go as the car's crew. Harry S. Houpt, whose enthusiasm, enterprise and liberality have in the past contributed so largely to Thomas racing prestige, will accompany them as manager, mentor and trainer.

When E. R. Thomas, with characteristic enthusiasm and patriotism, essayed to make an entry for the Grand Prix, he had in mind the construction of a full team of three special racing cars, so as not to be behind his European rivals in preparedness for the great test. Pressure at the factory, however, in getting out the 1908 models left no time or opportunity for the extra work of designing and constructing a trio of racing machines. Instead of a trio of racers, he will, of necessity, have to pin his chances to a single stock car, whose only variation from the standard model turned out for customers will lie in the bore, being 5-8 of an inch larger than that of the regular stock Thomas Flyers. There has not even been time to satisfactorily try out the present car, which is, of course, far from a racing car, when one compares it with the specially built and long-tested European cars that the Thomas will have to go against.

In securing Strang and Marquise, who manned the victorious Isotta at Savannah and Briarcliff, and prevailing upon Mr. Houpt to accompany them as manager, Mr. Thomas has shown characteristic forethought. His car will be assured of the best driving and handling that the United States affords. That the attempt will result in more than the Thomas demonstrating the lasting qualities of the best American stock cars under high speed road conditions, Mr. Thomas has little hope, in view of the handicap he has shouldered.

### Mr. Houpt a Conscientious and Energetic Sportsman.

Mr. Houpt was the first to give the Thomas a try in an international race. How he put up Montague Roberts in the first Vanderbilt elimination trials and won a place on the team, only to have his car shelved in favor of an arbitrary selection by the committee then in charge, is racing history. Mr. Houpt's attempt, however, was at the bottom of the serious try Mr. Thomas made in 1906 for Vanderbilt Cup honors, when he built at an enormous expense three racing machines and engaged Le Blon and Caillois, two French cracks, to drive two of them, his

return being the beating by Le Blon of all other American cars in the race. The long period of uncertainty as to the completion of the Long Island parkway ending in the abandonment of the Vanderbilt race of 1907 discouraged Mr. Thomas from his purpose to build other cars for another try. Grand Prix rules and restrictions prevent his using the three racing cars on hand.

The Thomas will not enter the race by any means unknown to European followers of automobiling. The beating it gave the French, German and Italian cars across the American continent in the New York-Paris race has given the Thomas an enviable introduction to foreigners. Mr. Thomas hopes that a creditable stock car demonstration in the Grand Prix will confirm the reputation his around-the-world car won. He really can hope for little more.

To-night, at the Hotel Marseilles, New York City, Mr. Houpt is to be the recipient of a dinner given in his honor by the Thomas staff and employees of the metropolitan district.

### GRAND PRIX COURSE CLOSED TO RACERS.

PARIS, May 9.—Racing cars have been forbidden access to the Dieppe course since the first day of the month, the penalty for infraction being disqualification in the Grand Prix. The Racing Board of the Automobile Club of France declares that this measure is necessary in order to safeguard the interests of the public and to allow the work of road repairing and tarring to be carried on with greater activity. Knowing that they would be deprived of their practicing ground Grand Prix drivers have been busy on the course, nearly every man engaged in the race having been round during the last few days of April on either fast touring cars or racers of last year's vintage. Very few of the 155-millimeter machines are yet ready, the only ones on the road at the present time being Renault, Panhard, Bayard-Clement, Motobloc, and Benz, this latter being handled by Hemery.

Prices for the boxes at the official grandstand have been fixed at \$90 for first boxes with 9 places, \$60 for the first boxes having six seats, and \$36 for the second row boxes, also with six places. Second row boxes, also with four places, are offered at \$24. Individual places are being sold at \$4 and \$3 each. For the voiturette race on July 6 there is a lower tariff, the reduction being about 25 per cent. Garage charges are fixed at \$1 for the first day and \$2 for the day of the Grand Prix.



Contrary to the usual custom the weighing-in ground will this year be open to the public at a charge of 40 cents per person for the voiturettes and the heavy cars.

The drawing of places for tire, gasoline, and oil stands opposite the grand stands took place by lot last week, the Racing Board holding this much earlier than usual in order that constructors who desired to do so might have grandstand seats opposite their depots. Any later engagements, either for cars or depots only will be given the remainder of the boxes in the order of their engagement.

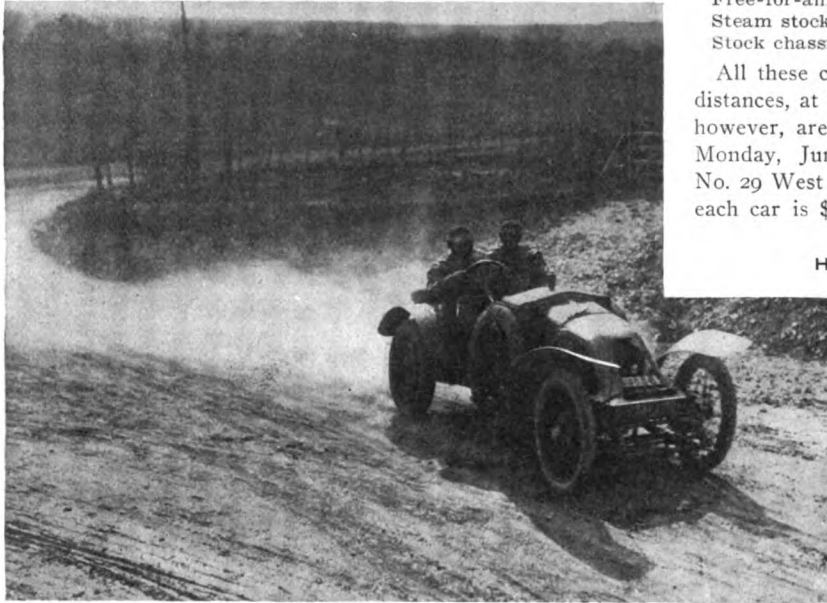

Callois and One of the 1908 Renault Trio.

#### BRITAIN ADOPTS LIMITED BORE FOR RACE.

LONDON, May 9.—In place of the fuel consumption race on the Isle of Man, which the Royal Automobile Club of Great Britain considers to have outlived all useful purposes, England will this year have a purely sporting event familiarly known as the "four-inch race." As in the Grand Prix, the essential features of the regulations are maximum bore and minimum weight. The Britishers, however, consider 155 millimeters too great a bore for four-cylinder cars, and are probably right in view of the nature of the course available for the race. Under the formula adopted practically only four-cylinder cars of 4-inch bore will be eligible, the weight being a minimum of 1,600 pounds without driver or mechanic, gasoline, oil, water, spare parts, tires, or tools. The formula reads: "The race is for cars the D<sup>2</sup>N of whose cylinders shall not exceed 64, equal to the R.A.C. rating of 25.6 horsepower. There must be not less than four working cylinders." D<sup>2</sup>N equals diameter of cylinders in inches squared and multiplied by the number of cylinders.

Under the Ostend agreement England has the right to conduct an international speed contest on other than the 155-millimeter rules, the understanding being that races for smaller cars could be held, but that no speed test should be held for machines of more than 155-millimeters bore for four cylinders. It is believed that in nearly every case practically stock chassis will be entered in the British race.

Though no course has yet been decided upon, it is almost certain that the race will be held on the Isle of Man sometime in the Fall. Entries, which must not exceed three per firm will be received at the rate of \$175 per car until July 1. Final closing, at increased fee, will be on August 1. With the exception that both dismountable wheels and dismountable rims will be allowed, the regulations governing the race will be similar to those of the Grand Prix. Thus all work must be done by driver and mechanic; there will be two depots for fuel, water, oil, and tires, and the use of oxygen, acetylene, etc., will be prohibited.

#### NINE CLASSES FOR JAMAICA STRAIGHTAWAYS.

Announcement has been made of the card for the straight-away time trials to be run at Jamaica, N. Y., on June 5, under the joint auspices of the Subway Celebration Committee and the Long Island Automobile Club. The events are:

Gasoline stock cars under \$1,250.

Gasoline stock cars from \$1,251 to \$2,000.

Gasoline stock cars from \$2,001 to \$3,000.

Gasoline stock cars from \$3,001 to \$4,000.

Four-cylinder stock cars over \$4,000.

Six-cylinder stock cars over \$2,500.

Free-for-all, all types and motive powers.

Steam stock cars.

Stock chassis having 301 to 550 cubic inches piston displacement.

All these classes prevail for the kilometer, mile, and two-mile distances, at which the time trials will be run. Separate entries, however, are required at each distance. The entries will close Monday, June 1, with Fred J. Wagner, assistant secretary, No. 29 West Forty-second street, New York. The entry fee for each car is \$15 for the first and \$5 for each subsequent entry.

Hemery, 1905 Vanderbilt Winner, Now Drives a Benz.

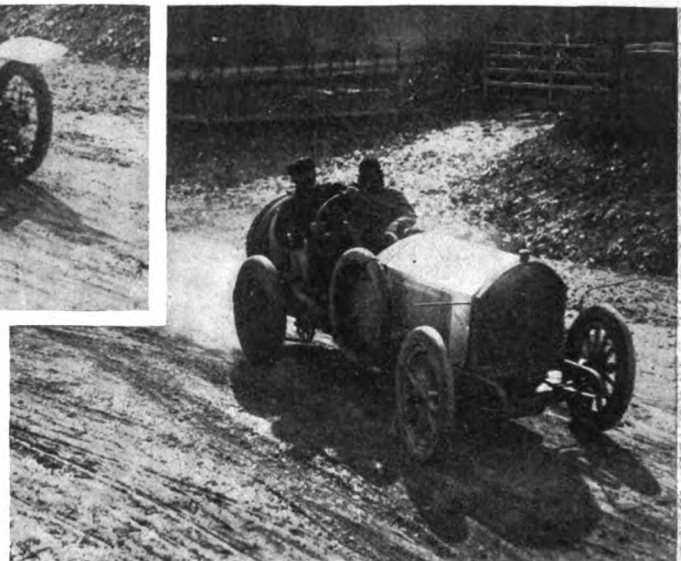

Heath, 1904 Vanderbilt Winner, Still Drives a Panhard.

#### EVENTS FOR DEAD HORSE HILL CLIMB.

WORCESTER, MASS., May 12.—The hill-climb committee of the Worcester Automobile Club having the arrangements for the third annual Dead Horse Hill climb in charge have decided to have fifteen events, all open to stock cars only. Men are now at work putting the Leicester end of the big hill in shape.

The committee is confident that the record of the hill of 1:01 2-5, made by the Darracq of Samuel B. Stevens, driven by A. L. Campbell, May 25, 1906, will be smashed.

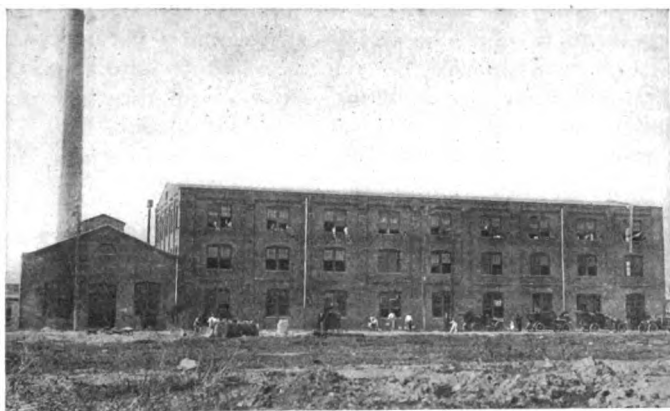

New Factory of the Ajax-Grieb Rubber Co., at Trenton, N. J.

## AJAX TIRE PLANT'S HOUSE WARMING.

With Governor Fort, of New Jersey, and Mayor Madden, of Trenton, as sponsors, and two hundred men prominent in the sport and industry as witnesses, the new plant of the Ajax-Grieb Rubber Company, at Trenton, was christened last Monday with due ceremony and much congratulatory jollification. There were speeches, not too many of them, a luncheon, vaudeville, bridge and pinochle tables, and an inspection of the new factory that was most instructive, interesting and impressive. Altogether the entire celebration spoke well for the generosity of the hosts and the confidence of the company in returning business prosperity.

The guests arrived in two special trains, the one from Philadelphia bringing forty Quakers and that from New York a bunch of 149 Knickerbockers. Landed by a private siding at the factory, the visitors were bidden by President Horace De Lisser to climb to the top floor of the main building, where Mr. Grieb was on hand to welcome them. The spacious room was hung with flags and bunting, and at one end a platform was erected. There was a long wait before Mr. Grieb arrived in a Ford, driven by Louis Block, with Mayor Madden, and a still longer one before Mr. DeLisser showed up with Governor J. Franklin Fort in a Maxwell, whose pilot for the occasion was J. D. Maxwell himself. There was a great snapping of cameras. New Jersey's Governor and Trenton's Mayor were loudly cheered as they proceeded to the platform.

President DeLisser began the factory's inaugural ceremonies by declaring that he was never so happy as when entertaining his friends, and that to-day his cup of happiness was running over. He paid a graceful tribute of gratitude to his associates and backers in the enterprise, mentioning by name Benjamin Briscoe, J. D. Maxwell, Henry Ford, James Couzens and William Mitchell Lewis, not forgetting William and Harry Grieb, R. A. Patterson and Alfred Reeves, associate directors, and paying a further compliment to Louis P. Destribats, who designed the factory. In conclusion he thanked Governor Fort and Mayor Madden for assisting at the christening.

Governor Fort made a happy and humorous address. He said he had kissed babies and attended banquets, but this was his first experience at starting what he knew would prove a great industry. He exhorted New Jersey as a State of great achievement and complimented Trenton on being the only State capital that did not have to live off of its Legislature. The starting of this plant gave great promise for the future. Pointing to the Ajax poster, he perpetrated the pun that "though Ajax tires, no one will ever tire of Ajax tires." He hoped the enterprise would prove as prosperous as the girl on the poster was beautiful.

Mayor Madden was brief in his remarks, confining them to the statement that the starting of this new factory at this time was a most encouraging sign of returning prosperity, and the wish that the enterprise might meet with success.

Then Governor Fort pressed electric buttons that set the wheel of the great Curtiss engine revolving and the rollers and grinders to work. Mr. DeLisser concluded the ceremonies by

inviting all hands to go below and see for themselves that the best rubber that could be bought was put in Ajax tires. The invitation was accepted, and the refining, mixing and calendaring processes were viewed with interest.

The new Ajax-Grieb plant consists of three brick buildings, one of three stories, 60 by 190 feet; a one-story press room, 80 by 200, and an engine and boiler room of one story, 40 by 90, giving 53,800 square feet of floor space. The acreage of the factory grounds is eight acres.

The founder of the enterprise was Horace DeLisser, who was formerly sales manager of the International A. & V. Tire Company. The company, which was founded on November 24, 1905, had the backing of the leading makers of the A. M. C. M. A., and fought the then existing tire combination. The first tire was completed January 1, 1906.

The Maxwell-Briscoe Motor Car Company was represented by Benjamin Briscoe, J. D. Maxwell, Frank Dorman and Richard Irwin; the Ford Motor Company by Louis Block, its Philadelphia branch manager, and W. L. Huston, president of the Standard Motor Car Co., of San Francisco.

## ASSOCIATED CLUBS ATTACK JERSEY LAW.

NEWARK, N. J., May 11.—At a meeting of the Associated Automobile Clubs of New Jersey, held at the clubrooms of the New Jersey Automobile and Motor Club last week, a committee was appointed, with W. C. Crosby, of Newark, as chairman, to secure counsel and begin proceedings to attack the constitutionality of the amended Freylinghuysen law. The license clause will be the first point attacked, but other provisions of the law may also be brought in question. President George Paddock, of the New Jersey Automobile Trade Association, was present, and assured the State body that the dealers would cooperate with the clubs in the proposed fight, while the latter have provided sufficient funds to secure the best legal talent available.

It is anticipated that George A. Post will resign as president of the associated clubs, as he did not desire the office when elected, and has since declared his intention to resign. In the latter event, W. C. Crosby, now vice-president, will probably succeed him as executive.

## SILVER PLATE FOR SECRETARY BONNELL.

NEWARK, N. J., May 12.—A noteworthy incident followed the conclusion of the recent annual meeting of the New Jersey Automobile and Motor Club in the presentation on behalf of the members of a silver service of over one hundred pieces to H. A. Bonnell, the retiring secretary, in recognition of his services during the two years of hustling administration. Orator J. H. Wood called attention to the fact that when Mr. Bonnell took up his office the club had but 375 members, and that its roll now numbered over 800. This is so rapidly growing that before long it is predicted that the club will have over 1,000 names.



President DeLisser Gives Governor Fort a Maxwell Ride.

# THE AUTOMOBILE

Vol. XVIII

Thursday, May 14, 1908

No. 20

## THE CLASS JOURNAL COMPANY

Flatiron Building, Madison Square  
New York City

H. M. SWETLAND, President

### EDITORIAL DEPARTMENT

A. G. BATCHELDER, Managing Editor  
R. F. KELSEY, Associate Editor C. B. HAYWARD, Engineering Editor  
W. F. BRADLEY, Foreign Representative

### BUSINESS DEPARTMENT

A. B. SWETLAND, Business Manager  
LOUIS R. SMITH FRANK B. BARNETT  
W. I. RALPH, 1035 Old South Building, Boston, Mass.  
C. H. GURNETT, H. E. WESTERDALE, 1200 Michigan Ave., Chicago, Ill.

Cable Address - - - - - Autoiland, New York  
Long Distance Telephone - - - - - 300 Gramercy, New York

### SUBSCRIPTION RATES:

United States and Mexico - - - - - One Year, \$3.00  
Other Countries in Postal Union, including Canada - - - - - One Year, 5.00  
To Subscribers—Do not send money by ordinary mail. Remit by Draft,  
Post-Office or Express Money Order, or Register your letter.

### FOREIGN SUBSCRIPTION AGENTS:

ENGLAND:—W. H. Smith & Sons, Ltd., 186 Strand, London, W. C., and all their  
railroad bookstalls and agencies throughout Great Britain; also in Paris at  
248 Rue de Rivoli.  
FRANCE:—L. Baudry de Saunier, offices of "Omnia," 20 Rue Duret, Avenue de  
la Grande Armee, Paris.  
GERMANY:—A. Seydel Mohrenstrasse 9, Berlin.

Entered at New York, N. Y., as second-class matter.  
The Automobile is a consolidation of The Automobile (monthly) and the Motor  
Review (weekly), May, 1902, Dealer and Repairman (monthly), October, 1903,  
and the Automobile Magazine (monthly), July, 1907.

Copies printed in 1905	- - - - -	730,000
" " in 1906	- - - - -	791,000
" " in 1907	- - - - -	888,000

## RESULTS ONLY THROUGH ORGANIZATION.

That the automobilists of the country will never obtain and retain conditions most satisfactory for the pursuit of their pleasurable necessity, except through thorough organization—locally, by States, and nationally—is plain.

One of the best organized State associations of the A. A. A. is the Pennsylvania Motor Federation, of which Robert P. Hooper is the enthusiastic president and Paul C. Wolff a most conscientious secretary. Its monthly pronouncement always contains much that strikes the mark exactly. We quote from the May bulletin:

The Federation was organized for two purposes: that it should be a State good roads association, and that there should be a body of motorists strong enough to secure the enactment of fair laws regulating automobiling, or to defeat any unjust or oppressive legislation that might be introduced.

We believe that the State associations should maintain a national body for the same reason that the clubs and individual motorists should support a State organization.

It has always been the experience of most organizers that the many prefer to allow the few to do the work. Gradually the present national association is adding to its State bodies, which in turn are gaining club after club, and the day is not far distant when two-thirds of the automobile users of the country will lend their financial and moral support to bettering the general conditions of automobiling. If there isn't a local club in your vicinity, see that one is formed of at least a dozen members,

for that is the reasonable minimum required for the organization of a club which can become a part of and have a spokesman in the councils of your State association. If there isn't a club, you can join direct as an individual member.

Certainly the surest way to obtain automobile peace is to complete the organization of a widely scattered army of automobile users, necessarily democratic in character, and reaching wherever a motor-driven vehicle adds to the comfort and longevity of life.



## EVOLUTION OF THE AUTOMOBILE CLUTCH.

Few better instances of the special requirements involved in the design of automobile parts could be cited than those given in connection with a review of the development of the automobile clutch, part of which appears in this week's issue of THE AUTOMOBILE. Conditions met with are so totally different that precedents are worse than valueless, though, as the writer of the article in question makes plain, there was little data available on clutch design even in the general engineering field, clutch makers having learned by experience what size clutch of their own make is necessary to transmit a given horsepower in machine shop practice. This was the state of affairs that confronted the automobile engineer at the outset, so that it is hardly to be wondered at that clutch troubles formed no small part of early defections.

Chief among the facts brought out by this highly interesting paper is that of the status of the cone type of clutch, which has held its own despite the numerous special types that have been introduced with a view to overcoming what have since proved to be not so much defects of design as lack of provision for the specially hard service to which the clutch is subjected. The discovery of the great value of cork as a friction material has also been instrumental in keeping this type in favor, and its use marks one of the greatest steps in advance where clutch efficiency is concerned.



## PROBLEM OF DUSTLESS ROAD BUILDING.

Despite the numerous ideas advanced for the building of an improved type of road, nothing as yet seems to have succeeded in superseding MacAdam's plan. In fact, the problem has somewhat resolved itself into a question of road preservation, and many master minds are now devoting themselves to the subject. Macadam construction has proven itself a superior form for a great many purposes, barring its rather important lack of permanency. In other words, under increased traffic it is subject to more or less rapid disintegration, and it is this feature that road builders all over the world are trying to remedy. Of the various methods experimented with, none yet appears to have proven so effective as the application of hot coal gas tar, which is not merely a surface treatment, as the tar percolates through to the lower strata of the road construction, binding it in an efficient and more permanent manner than has heretofore been the case with similar applications of other materials. Up to the present, this appears to be one of the most successful methods adopted, and the further experimenting now being carried on at Hartford and Savannah should bring out further facts in its favor.

## A. M. C. M. A. TALKS OF ITS OWN CHICAGO SHOW

THAT discussion of the idea of promoting an independent show in Chicago along the lines of its policy of holding exhibitions of its own, as in the case of the Grand Central Palace function in New York, occupied some of the attention at the meeting of the Committee of Management of the American Motor Car Manufacturers' Association, held at its New York headquarters on Tuesday, is evidenced by the show committee being empowered to make arrangements therefor. In its official announcement of the proceedings, the Association's publicity department states that in accordance with letters from Chicago, associated in the Western show will also be the Chicago Automobile Club and the Chicago Motor Club.

The question of program advertising was also discussed, with the result that it was voted that in view of the fact that this class of advertising is many times of questionable value, the use of such mediums should be discouraged.

The show committee reported on the arrangements for the Grand Central Palace show, to be held December 31 to January

7, in conjunction with the Importers' Automobile Salon and the Motor and Accessory Manufacturers, Inc. E. R. Hollander has been named to represent the importers on the show committee, and D. J. Post will serve the interests of the Motor and Accessory Manufacturers.

Upon the recommendation of the good roads committee, the association appropriated \$500 for the A. A. A. National Legislative and Good Roads Convention, to be held at Buffalo, July 8 and 9.

There was a full attendance of the Committee of Management, including Benjamin Briscoe, chairman (Maxwell-Briscoe Motor Co.), R. E. Olds (Reo Motor Car Co.), James Couzens (Ford Motor Co.), H. O. Smith (Premier Motor Mfg. Co.), G. V. Rogers (Mitchell Motor Car Co.), W. H. VanDervoort (Moline Automobile Co.), C. G. Stoddard (Dayton Motor Car Co.), S. H. Mora (Mora Motor Car Co.), Charles E. Lewis (Jackson Automobile Co.), Job Hedges, the association's counsel, and Alfred Reeves, general manager.

### THE "SOLID SOUTH" WANTS CUP RACE.

NEW ORLEANS, LA., May 11.—The success of the Savannah stock-car races did much for the automobile trade in the South, which is now much interested in the selection of the course for the Vanderbilt Cup race. It is a "Solid South" for Savannah. Dealers in this city, as well as in all the other larger Southern cities, are of the opinion that the holding of this race below the Mason and Dixon line would be the best thing that could happen for the Southern interests.

A local dealer expresses the opinion that the Savannah race awakened more real interest in automobiles, and particularly in the good roads movement than anything else in recent times.

A movement has been started here, and which is about ready to carry into operation, for the building of an automobile road between New Orleans and Baton Rouge. This road is to follow the Mississippi, and when completed will, without doubt, be the best 100-mile road in this part of the country. Then, too, a road is now being built between this city and Chef Menteur on Lake Pontchartrain, which is 25 miles long. This road is built of shells, is white as snow, level and very fast.

Chef Menteur is right in the heart of the fishing and hunting sections. When the road to Baton Rouge is completed this will make one of the finest roads in the country, and about 125 miles long.

### CHANGES IN N. A. A. M. REPRESENTATION.

At its regular monthly meeting held in New York City, May 6, the National Association of Automobile Manufacturers received the resignations of W. E. Metzger, as representative of the Cadillac Motor Car Company; V. M. Gunderson, as representative of the Northern Motor Car Company; H. E. Coffin, representing the E. R. Thomas Detroit Company, and E. R. Chapin, the E. R. Thomas Motor Company of Buffalo. Mr. Metzger was then re-elected to succeed Mr. Gunderson as representative of the Northern company, in which the former Cadillac general sales manager is known to have been considerably interested for some time, and Mr. Chapin was re-elected to fill the vacancy caused by Mr. Coffin's retirement. The Cadillac company and the E. R. Thomas Motor Company have not as yet nominated their new members.

### WASHINGTON GETS TAXICAB HABIT.

WASHINGTON, D. C., May 9.—Motor taxicabs are making a big hit in Washington, and it is likely several companies will be operating them here before the end of the summer. The Federal Taxicab Co., of which E. R. Thomas is president, was the first to invade the field. Six Elmore taxicabs were placed in service here last week by the New Union Garage Company.

## LAND OF EVANGELINE IS DECREED TO BE AUTOLESS

WOLFVILLE, N. S., May 11.—In order to appease a few irate and misguided agriculturists who look upon the automobile as the incarnation of evil, the Provincial Legislature, otherwise the House of Assembly and the Legislative Council, recently passed an amendment to the motor vehicle law. This makes it lawful for every city, town, or municipality in the Province of Nova Scotia to make regulations prohibiting the use and operation, on certain days of each week, of motor vehicles, upon any of the public highways, etc. So far Pictou county has been the first to take advantage of the law, and has prohibited the use of automobiles within its borders on every day except Monday.

As the direct result of this retrogression to the dark ages, the Nova Scotia Automobile Association has sprung into being, its chief object being the protection of its members against this form of tenth century legislation. The secretary of the new association is W. L. Kane, Halifax, N. S.,

and American tourists who have thoughts of including the "Land of Evangeline" in their itineraries for this summer would do well to consult Mr. Kane in advance before going to the expense of taking their cars to this now hostile country. The prohibitory movement is as yet in its infancy, Cumberland county being the only one that has followed the example of Pictou, though it has not gone to the same extreme, Monday, Thursday and Sunday being the black letter days in Cumberland. But others are quickly falling into line. The County Council of Kings has appointed a committee to confer with the Councils of Annapolis and Hants, to select prohibitory days, with a strong recommendation that only two days in the week be left open. It is currently reported that it is the desire of some of the councilors for each county and town to select different days, thus making the prohibition absolute for all practical purposes. As an example of restrictive legislation the above is about "the limit."



### CELEBRATE FOURTH WITH ROAD RACE.

BOSTON, May 9.—To concentrate its Fourth of July celebration into an automobile road race is the idea which has been suggested to the people of Lowell. The scheme of a 200-mile road race on a 10-mile course to the north of the city was broached only a week or so ago, but since then events have been moving rapidly. An organization called the Lowell Automobile Club has been formed, with John O. Heinze, of the Heinze Electrical Company, as president; Frank S. Corlew, prominent in the New England automobile trade, as vice-president; John A. McKenna, secretary, and Harry Dunlap, as treasurer.

This club has applied for membership in the Massachusetts State Automobile Association of the A. A. A., and has also applied for a sanction for its race meeting. In addition, the club has been offered a costly trophy for the race, the donor being Congressman Butler Ames, grandson of General Benjamin Butler, and arrangements are being made to have the militia of Lowell, and, perhaps, of the neighboring city of Lawrence, turn out to do guard duty during the race, it being claimed that the services of the militia can be secured on the holiday without the usual order from the Governor. The roads that are to be used are to be improved where necessary, corners banked, and given a thorough oiling. A large grandstand is to be erected, and the Lowell club plans to invite prominent members of the A. A. A., experienced in road racing, to act as officials. Vice-President L. R. Speare, it is said, has already consented to officiate as referee.

### NEW CUPS FOR GIANTS' DESPAIR CLIMB.

WILKES-BARRE, PA., May 5.—All obstacles to an A. A. A. sanction having been removed, the Wilkes-Barre Automobile Club is preparing to make its annual Decoration Day climb up Giant's Despair far bigger and more noteworthy than any former one of the series. John Willis Hollenback's offer of a cup costing from \$500 to \$1,000, to be competed for annually, has been accepted. A feature of the climb will be the patrolling of the course by the C. T. A. U. regiment, an independent military body which has volunteered. The program will embrace nine other events.

The following program has been arranged:

- Event 1.—Gasoline stock cars, \$850 or less.
  - Event 2.—Gasoline stock cars, \$851 to \$1,250.
  - Event 3.—Gasoline stock cars, \$1,251 to \$2,000.
  - Event 4.—Gasoline stock cars, \$2,001 to \$3,000.
  - Event 5.—Steam or gasoline stock cars, \$1,250 to \$3,000.
  - Event 6.—Gasoline stock cars, \$3,001 to \$4,000.
  - Event 7.—Four-cylinder stock cars, \$4,000 or over.
  - Event 8.—Six-cylinder stock cars, \$2,500 or over.
  - Event 9.—Free-for-all types and motive power.
  - Event 10.—Gasoline stock chassis not exceeding 103.87 total piston area.
  - Event 11.—Steam cars.
  - Event 12.—Cars owned by Quaker City Motor Club members.
- Event No. 10 is intended for Briarcliff models and will have a special cup for its prize.

### BRIDGEPORT CLUB TO PROTECT CITIZENS.

BRIDGEPORT, CONN., May 12.—The Automobile Club of Bridgeport is to take summary action against the dangerous driving of reckless and incompetent chauffeurs. The subject was brought before the club by complaints against one or two chauffeurs on the occasion of the club run to the Briarcliff race. By resolution, a committee of public safety has been established, which will include a lawyer.

President Staples has appointed the following as the club's delegates to the Connecticut State Automobile Association, which will hold a meeting in Bridgeport, May 30: Frank Miller, F. W. Bolande and Silas Burton. The board of governors has been increased to twelve members.

Robert M. Cranford, of New York, has presented the Cranford cup to take the place of the Gale cup, which he won at last year's hill-climb.

### THE THOMAS CAR ARRIVES IN JAPAN.

According to a cable to the New York *Times*, the Thomas car and its American crew arrived at Yokohama on the *Show-mut*, May 10, after an 18-day passage, but, much to the disappointment of the American colony, the car was not disembarked. The foreigners had paraded through the town and received a great reception from their compatriots, and the Americans were eager to show them what their representative could do, but the Thomas, unfortunately, remained on the steamer, being unloaded at Kobe. From the latter place, Schuster will run it over the mountains to Tsuruga with the aid of a Japanese guide, and will take a steamer from there for Vladivostok, Friday, May 15.

The French committee in charge of the race held a meeting at Paris, May 7, in order to pass upon the questions arising from the change of route made necessary by the impassibility of the Alaskan trail. It was decided that the Thomas car be allowed 15 days over its nearest competitor in the trip through Siberia owing to the advantage it lost by going to Alaska, while the committee further decided that the Protos be penalized 15 days for shipping from Ogden to Seattle, thus placing it 30 days behind the Thomas. The Russian committee is said to have made all preparations in the way of fuel and supplies along the route, so that everything is in readiness for the start when the American car reaches Vladivostok.

### SILVER TROPHIES FOR LONG ISLANDERS.

BROOKLYN, N. Y., May 11.—In a letter to the members that fairly bristles with evidences of an active club life, Charles Jerome Edwards, president of the Long Island Automobile Club, calls their attention to the fact that the open season for automobiling has arrived, and to the several silver cups offered for club competition.

The membership cup, offered by Louis T. Weiss, will be awarded to the member securing the greatest number of recruits during the year ending December 31, 1908, while the attendance cup, offered by Leffert Lefferts, will be presented to the member attending the greatest number of club runs and contests during the same period. The mileage cup, presented by President Edwards, will go to the member whose odometer registers the greatest distance traveled during the touring season, beginning May 1 and ending November 1, the club manager, H. H. Creighton, keeping a record of the speedometers. Beside the foregoing, there is a touring cup, offered by Samuel H. Burns, for the member who tours in the greatest number of States or Provinces during the touring season ending November next.

The first club run of the season to the country clubhouse at Bay Shore, Long Island, is announced for May 17, while the contest committee announces a series of contests to be held June 5, on Hillside avenue, Jamaica, in connection with the Jamaica Citizens' Subway Celebration.

### EVANS JOINS A. A. A. GOOD ROADS BOARD.

PHILADELPHIA, May 11.—Powell Evans, president of the Automobile Club of Philadelphia, has been made a member of the executive committee of the Good Roads Board of the American Automobile Association. President Evans is responsible for much of the recent activity of the Philadelphia club, which is accomplishing excellent work in Philadelphia and vicinity. Secretary S. Boyer Davis is also entitled to a good bit of the credit for recent results.

### NEW YORK TO CELEBRATE ORPHANS' DAY.

There is now small likelihood that the New York end of the Greater City's celebration of Orphans' Day will be allowed to go by default this year. The probabilities favor the New York Automobile Trade Association undertaking the promotion of the celebration as the outcome of a conference of its leaders and several charitable outside enthusiasts held yesterday.

## AMERICAN LOCOMOTIVE MOTOR CAB.

By B. D. GRAY, CHIEF ENGINEER, Am. Loco. Auto. Co.

**I**N the motor cab produced by the American Locomotive Automobile Company, of which the first hundred are now being put into service by the Waldorf-Astoria hotel in New York, is found a new attitude toward the economic aspect of the tariff cab for city use. This attitude is the habitual one of this company which believes that building for long service is most economic in the end, even at a slightly greater initial cost.

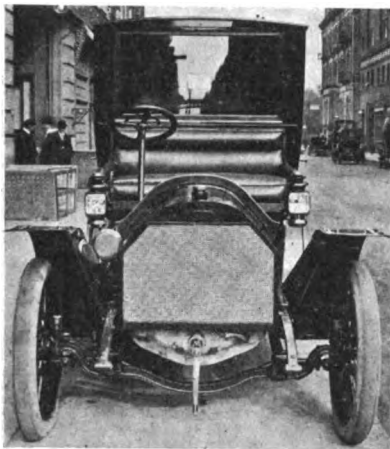

"Bow View" American Berliet Cab.

Having decided to enter the field the American Locomotive Automobile Company made an exhaustive investigation of the various makes of cabs and the conditions under which they are operated, both here and abroad. The results of this indicate that the requirements of the service are exacting in such a way that a cheaply constructed vehicle is unlikely to be lucrative. It was found to be the experience of some companies that while the gross receipts were ample, the net profit was nil, owing to the vehicles being in commission only about 50 per cent. of the time, and that to be finally profitable such vehicles should be so constructed that they can be kept in commission about 85 per cent. of the time. It is not practicable to exceed this figure, owing to the periodical necessity of repainting and overhauling, and the occasional repairs necessary to the best of power plants.

Engaging in the manufacture of cabs the American Locomotive Automobile Company, for the reasons cited, undertook to produce a vehicle in which the resistance to wear was the prime consideration and the expense of material and construction secondary. Generally speaking, the motor cab is built on the same lines and of the same material, and with the same exacting methods as the Locomotive Company's touring car, which occupies its own distinctive pedestal, the chief feature of difference being in the final transmission of power from the gear case to the rear wheels, which, in the case of the cab, is not by chains, but by a shaft drive. Imported materials are used in such important parts as cylinders, crankshaft, springs, frames, etc. The general specifications of the cab are as follows: Wheelbase, 103 inches; tread, 55 inches; height of frame from ground, 24 inches; weight of cab complete, 2,600 pounds; tires, 32 by 4 inches all around; available body space from dash to rear of frame, 98 inches; width of frame, 34 inches.

The motor is of the four-cylinder vertical type, placed forward of the dash under the usual form of bonnet, bore and stroke, being 3 15-16 inches by 4 3-4 inches; nominal rating, 16-horsepower at 800 r.p.m. Multiple disc clutch is used of the same type as is used in the Berliet cars. The ignition is low tension, make-and-break, with Simms-Bosch magneto. No spark advance is provided, this having been predetermined with the idea of precluding the possibility of an inexperienced driver abusing the motor. In further carrying out

this idea, a governor control is provided, whereby the maximum speed of the motor is limited to 800 r.p.m. This control is extremely sensitive and absolutely reliable.

The lubrication of the motor is effected entirely by splash, oil being fed to the crankcase by means of gravity through a sight feed oiler. As a guarantee against excess of oil and consequent smoky exhaust, hollow plugs are provided in the bottom of the crankcase to maintain a constant oil level, any excess being carried off to an overflow tank through these plugs. Cooling is effected by an extremely efficient honeycomb radiator, the water being circulated by a centrifugal type of pump, which has ample capacity to cool under most trying conditions.

The transmission is of the selective sliding gear type, providing three speeds and reverse, the high gear being direct. The reduction on the high gear is 3.8 to 1, giving a vehicle speed of 20 miles an hour with the maximum motor speed indicated.

The rear axle is, perhaps, the most novel feature of the cab, because of its being a peculiar design, distinctive to the American Locomotive Automobile Company. The axle proper, or the load supporting member, is composed of a one-piece drop forging, consisting of a large central ring and terminating in a tubular section at each end, and the tubular section being ribbed, top and bottom, to the central ring. This forging is so designed as to give as nearly as possible a theoretically correct distribution of metal to perform its several functions. The spring seat and brake anchor are integral and fitted rotatively on this forging, therefore transmitting the braking torque through springs to the frame. Special attention has been given to the location of spring suspension, as that feature makes so much for the comfort of the passengers as well as for the life of the motor.

Hess-Bright (D. W. F.) bearings are used throughout the transmission, rear axle and in the front wheels. Interchangeability has been made a very important factor in the construction, by virtue of which it is possible to replace any of the important elements, such as front or rear axle, transmission, motor, steering gear, etc., from stock, without having to specially fit or line up the part. Accessibility is another important feature, it being possible to examine practically the working parts individually without disturbing other adjacent parts. For example, the clutch or gear-set may be removed as a unit, and the same is true of the motor and rear axle.

Besides seeking to produce a cab to stand the racking of traffic service in the city, it has been the aim to provide a vehicle which shall have the luxurious riding qualities of a private car, and further to equip the chassis with a body as substantial and elegant as for high-class individual work.

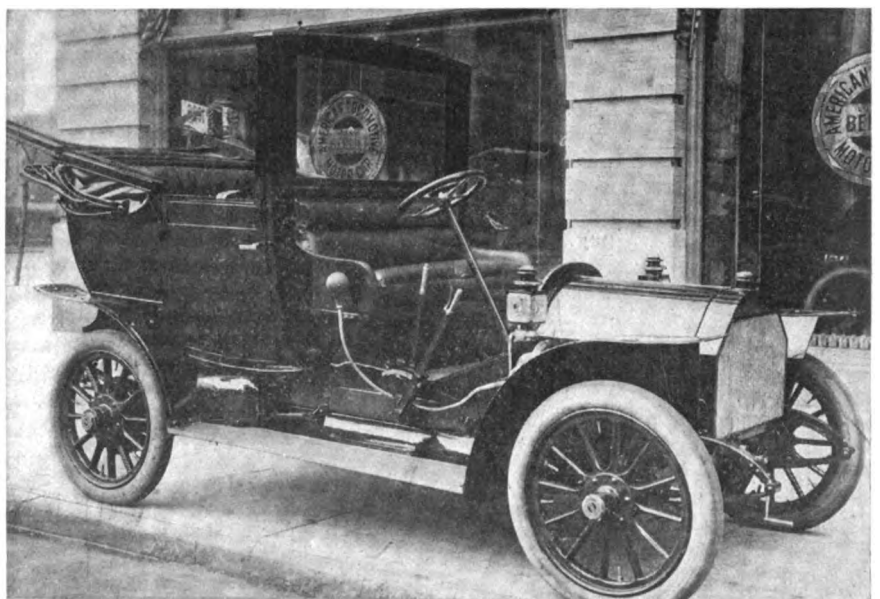

Attractively Substantial Lines of the American Locomotive Auto Company's Cab.

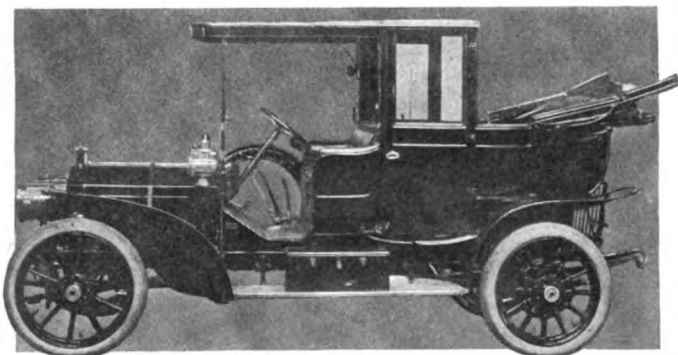

Standard Flandrau Landaulet on Packard Chassis.

### NEW YORK CITY A BODY BUILDING CENTER.

Few outside of those directly engaged in the automobile trade realize what a center New York City has become for the high class body builders. It held that post of honor long before the automobile came upon the scene, the numerous carriage manufacturing houses who have been in business here for more than half a century having become specialists in the art of body building for the automobile, and it has been extended even beyond what has been customary in the fitting up of the finest carriages. One of the most prominent of the houses in question is Flandrau & Company, 406-412 Broome street, New York, and a typical sample of their work is shown on a Packard chassis by the accompanying photograph. It is the standard landaulet body made by this firm and is designed to seat five passengers inside and one beside the driver, although it can be made to carry six inside if desired. The color scheme in this case was green, the panels being painted in a special shade ground by the makers for this order, while the inside is trimmed with leather made especially to match the color of the paint. The interior fittings, such as the dome light, card cases, foot rest, speaking tube and the like are all of exclusive patterns, the whole design producing a most striking effect in conservative colors.

### PIERCE ARROW FOR ST. PAUL FIRE FIGHTERS.

Through their St. Paul agent, the George N. Pierce Company, Buffalo, N. Y., have just supplied the fire department of that city with a car specially built to aid the fire fighters. The car is one of the 45-horsepower, four-cylinder type of the Great Arrow product, its lines being illustrated by the accompanying photograph. The body has been built specially for the purpose, having a disappearing rear seat. The under portion of the body is arranged to accommodate boots, helmets and the other paraphernalia of the fire chief, for whose use the car has been specially provided. The official in question realized some time ago that the usual horse and buggy were not adequate to the requirements and the order for the Pierce resulted.



St. Paul's Fire Chief in His New Pierce Great Arrow.

### OIL REFINERS INSTITUTE LITIGATION.

PHILADELPHIA, May 11.—As the result of the wholesale pirating of trade-marked brands of lubricating oils that has been carried on during the past half year, eight separate actions to recover an aggregate amount of \$35,000 as damages, have been filed in the Common Pleas court by J. R. Wilson, representing Charles F. Kellom, a pioneer American refiner of lubricants. Other actions will follow shortly, it being the plan of the plaintiffs to bring suit against all dealers and users, such as supply stores and garages, who have been handling an alleged spurious imitation of the Kellom brand of "Invader" oil. Serious charges of fraud and deception are made against the defendants in a number of the suits, the imitations having been purchased by agents of the plaintiffs in numerous cases in which the dealer guaranteed the oil to be the genuine Invader brand, while the chemist's analysis showed it to be quite the contrary.

Practically all the defendants in the first eight actions are garages. It is commonly reported that several other well-known refiners of lubricating oils find themselves in a similar position where their brands are concerned, small dealers all over the country selling inferior products under their name, refilling their trade-marked cans with cheap oils, and the like.

### RUSHMORE OBTAINS FURTHER INJUNCTION.

NEW YORK, May 11.—Following up its policy of obtaining injunctions against lamp manufacturers who are alleged to have been turning out colorable imitations of its designs, the Rushmore Dynamo Works, Plainfield, N. J., recently obtained a favorable decision against the Badger Brass Manufacturing Company, by Judge Lacombe, sitting in the United States Circuit Court for the Southern District of New York. The decision takes the form of an injunction forbidding the defendants to make or sell lamps in colorable imitation of the Rushmore flare front design. The decision is one of a number resulting from litigation instituted in November, 1907, and which has resulted favorably throughout for the complainants. It is especially worthy of note, as the question, at no time, has been one of patents, but of unfair competition, the doctrine involved being that of illegality of competition by means of imitations—something of long standing in England, but one that has not been recognized to any great extent in this country up to within very recently.

### LELAND HAD A MINIMUM OF TIRE TROUBLE.

In the course of the story of the Briarcliff race which appeared in THE AUTOMOBILE, it is stated that Leland, one of the Stearns drivers, was delayed to a considerable extent by punctures and other damage to his Pennsylvania tires. When this was called to Leland's attention by the manufacturers, the Pennsylvania Rubber Company, Jeannette, Pa., he stated that his Pennsylvania tires supplied the best performance that he had in his racing experience, having been adopted after previous testing of various tires for this purpose, the dismantlable rims the car was equipped with having been responsible for the delay.

In addition to Leland's statement, F. B. Stearns said that the Pennsylvania tires used in the trials and during the race showed up so well that he was enthusiastic over them. "I have used several sets of these tires beside those used on the racing car and they have been very satisfactory," added Mr. Stearns, "and I am also recommending my friends to use Pennsylvania tires."

### NEWARK MAY HAVE AN AUTO FACTORY.

NEWARK, N. J., May 11.—A rumor is current here to the effect that an automobile manufacturing plant is to be established here within the next few months. A two-cycle gasoline car, on which patents are said to be held by a local mechanic, will be built, the first model, which will be a 30-horsepower runabout, being turned out on a small scale. A. H. Newton is said to be back of the concern which is now being organized.

**PENNSYLVANIA ENTRANT FOR VANDERBILT.**

BRYN MAWE, PA., May 11.—As the result of the continually increasing demand for a very fast semi-racing type of car, the Auto Motor Company, builders of the Pennsylvania cars, have decided to bring out a stock car to be known as the "Vanderbilt" model, and it is also the intention of the makers to enter one of these cars in the Vanderbilt race next fall. The power plant will consist of the valve-in-the-head type of motor that is a distinguishing feature of the Pennsylvania car, its dimensions being 41-4 by 41-4 inches; it will also have the same type of unit axle and transmission. The wheelbase will be 105 inches, and the car will be guaranteed to develop 75 miles an hour.

In addition to the foregoing, this firm is also bringing out a new "Pennsylvania 25," officially known as Type D, which will be a five-passenger touring car or roadster, embodying the same features of construction as the Vanderbilt model referred to, and designed to sell at \$2,250. The first of this model will be on the road in about six weeks and, as a number of orders are already booked for them, shipments will begin about August. The company is now planning a 125 by 281-foot, two-story addition to its plant, which will be devoted to the manufacture of a four-cylinder two-passenger roadster car to sell at \$1,200.

**INDIANANS WILL HAVE SEALED BONNET.**

INDIANAPOLIS, IND., May 11.—All arrangements have been completed for the sealed bonnet contest to be held under the auspices of the Indianapolis Automobile Trade Association on May 20. However, it has been decided not to divulge the route or conditions until about two days before the contest. George Weidley, of the Premier Motor Manufacturing Company, is chairman of the committee having the event in charge.

**HOW OVERLAND CARS ARE COMING THROUGH.**

INDIANAPOLIS, IND., May 4.—Since the Overland Automobile Company, of this city, was reorganized last fall, J. N. Willys, of the American Motor Car Sales Company, becoming president; W. H. Brown, of the Pope-Waverly Company, vice-president, and P. D. Stubbs, of the Knox Automobile Company, secretary and treasurer, it has progressed very rapidly, producing more than double the number of cars since March 1 of this year than it did in all its five years' previous existence. The accompanying photograph of the assembling department of the Overland plant serves to give some idea of the rapidity with which the Overlands are now being put through the works, five complete cars being turned out each day. The demand for the Overland has grown so that the company is now considerably behind its orders.

**FINAL STANDING HARRISBURG CONTESTANTS.**

HARRISBURG, PA., May 11.—At the conclusion of the painstaking and exhaustive examination of the technical committee, it was generally conceded that the endurance run of the Automobile Club of Harrisburg had been conducted in a most thorough and sportsmanlike manner, the sole discordant note being the protest of the Rambler entrant, No. 25, driven by A. H. Bitner, which was penalized 17 points for loose hand brakes, W. F. Smith, the Philadelphia agent of the Rambler, claiming that the penalty was excessive, although Rule 24 bound all entrants to accept the technical committee's findings as absolute. The White in Class A, driven by Walter White, and C. C. Cumbler's Pullman in Class D, were the only all-round clean scorers, each winning two cups.

The appended table shows the penalties imposed in all four classes for both road faults and technical defects:

No.	Car	Driver	Road Penalties	Technical Penalties	Total
<b>CLASS A</b>					
28	White	Walter White	0	0	0
16	Thomas	C. C. Fairman	0	15	15
5	Pullman	Robert Morton	65	0	65
7	Pullman	J. A. Kline	61	60	121
10	Stoddard-Dayton	Robt. Shirk	189	0	189
18	Pierce-Arrow	Arthur Kumpf	0	..	Out
<b>CLASS B</b>					
22	Mitchell	W. M. Cram	0	2	2
19	Maxwell	Chas. Fleming	2	4	6
21	Maxwell	A. Bender	6	19	25
6	Pullman	M. Graupner	30	21	51
3	Cadillac	C. C. Crispen	4	76	80
23	Jackson	Chester Smith	15	..	Out
15	Elmore	A. D. Miller	51	..	Out
<b>CLASS C</b>					
8	Pullman	Stuart Lafean	0	6	6
27	Pennsylvania	L. Fuegel	0	11	11
25	Rambler	A. H. Bitner	0	17	17
17	Apperson	C. J. Swain	13	5	18
4	Pullman	E. G. Irvin	9	56	65
11	Stoddard-Dayton	H. Hodson	0	..	Out
<b>CLASS D</b>					
12	Pullman	C. C. Cumbler	0	0	0
14	Atlas	F. K. Mears	141	15	156
20	Maxwell	J. E. Sellers	146	66	212
24	Ford	A. A. Jones	350	96	446
9	Pullman	C. C. Cocklin	450	29	479
2	Jackson	H. G. Zimmerman	0	..	Out
1	Cadillac	R. H. Hagerling	0	..	Out

**Quakerites Also Now Travel in Taxicabs.**

PHILADELPHIA, May 11.—Last week witnessed the first indication here of the taxicab fever which is now sweeping over the country. Ten of the Thomas variety arrived in the city, and although they have not yet been put at work, the close of the present week will see them in operation from one of the big hotels. The remaining forty vehicles of the first installment will probably be delivered before the close of the month, which number will be sufficient to make a start.



Capacious Assembly Room of the Factory of the Overland Automobile Company, at Indianapolis.



## BRIEF ITEMS OF NEWS AND TRADE MISCELLANY

Dallas, Tex., has opened an automobile school which will be the largest, and, in fact, the only school of that character in the Southwest. J. W. B. Jeffords is president and manager, and W. A. Fosdick, vice-president and treasurer.

The Fairweather Club is to banquet the New York Carnival Committee on June 3. The report of the committee, by the way, will be presented at another dinner, to be given at the Hotel Brevoort on Saturday evening, at which the newspaper men are to be guests of honor.

Although the touring season is hardly under way as yet, the makers of the Elmore two-cycle cars have been agreeably surprised to find that their guarantee of 2,000 miles on one set of dry cells with the Atwater-Kent ignition system now installed on the Elmore, is being greatly exceeded in every case.

The Lockport Rubber Company, Lockport, N. Y., is a new concern organized to manufacture pneumatic tires, inner tubes and sundries in addition to complete lines of rubber goods for other purposes. The officers are Charles F. Kelly, president; J. Edwin Davis, vice-president; H. M. Wood, secretary. The concern is capitalized at \$300,000.

American products have long been making inroads into European commerce, but one of the first cases on record where a foreign war department has gone abroad for part of its equipment is to be seen in the case of the Dutch army, which has decided to equip its entire motorcycle corps with Solar headlights, which is a gratifying victory for the Badger Brass Manufacturing Company, Kenosha, Wis.

One of the buildings of the new plant of the Speedwell Motor Car Company, at Dayton, O., is now about ready for occupancy, while two more of the same size, measuring 30 by 150 feet, are now in course of construction. The working force now numbers about 75 men and orders are being received in such numbers that it has been found necessary to ship the cars by express in order to meet the demand.

The Gearless Motor Car Company, Rochester, N. Y., makers of the Gearless cars, has just been reorganized with the following incorporators: William Bausch, vice-president of the Bausch & Lomb Company; George F. Roth, collector of customs at Rochester; W. H. Rogers, president of the Rochester Tile & Brick Company; John W. Breyfogle, vice-president and treasurer of the Gearless Transmission Company, and John J. McInerney, attorney. The new company will be under the same management as at present and will continue the same plant and offices.

As the result of the various city ordinances in different parts of the country, excluding cars carrying non-skid chains and similar devices from park roads, the Republic Rubber Company has brought out a new tire equipped with what is known as the "Staggard Tread." This consists of five large ribs, which are cut transversely at intervals of an inch so that studs are left about the shape and size of a lozenge, this style of corrugation having the advantage of not working off or pulling loose. As it is entirely of rubber, there is no hardening of the tread of the tire and consequently no loss of resiliency.

A rumor has been current to the effect that John H. Patterson, president of the National Cash Register Company, has been negotiating with Alexander Winton, for the sale of the Cleveland factories of the company, of which Mr. Winton is the head, and that the cash register concern was about to embark in the manufacture of automobiles. Mr. Winton declares the rumor to be without foundation, and Charles B. Shanks, sales manager of the company, says: "I don't think Mr. Patterson, or anybody else, can buy the Winton company. We have been successful in the automobile business since its inception, and the outlook is that we will continue to be a strong factor in the trade."

### TRADE CHANGES OF LOCATION.

The Chicago agency of the E. R. Thomas Detroit Company has been removed from the salesrooms of C. A. Coey & Company, on Michigan avenue, to Levy & Fanning, 390-392 Wabash avenue. George W. Hipple, who has been making a marked success in handling the Thomas-Detroit line, will be continued as branch manager. Mr. Hipple has been in charge of the Thomas-Detroit business in Chicago since it was established there last February.

The Swinehart Clincher Tire & Rubber Company's New York office will remove to 875 Seventh avenue June 1. The company has leased a three-story building at the above address and it will be devoted entirely to housing the Swinehart tire interests in New York. A similar building has been leased at 1720 Michigan avenue. Chicago, for the use of that branch and will be occupied July 1. It has been found necessary to secure larger quarters for both branches, owing to the fact that the work could not be handled at the old locations.

### NEW AGENCIES ESTABLISHED.

The Percy Ford Company has succeeded Leon Rubay Company, at 226 Columbus avenue, Boston, and will do a general automobile supply business.

The S. & M. Supply Company is a new concern in the accessory field that has just opened business at 177 Portland street, Boston. A complete line of supplies and accessories of all kinds will be handled.

Bernard F. Goss has been appointed agent for the Atlas Motor Car Company, of Springfield, Mass., at Hartford, Conn., and will handle the Atlas line in that territory. He has established headquarters at 1124 Main street.

With a line already the largest in the city, the Bergdoll Motor Car Company, Philadelphia agents for the Benz, Berliet, Welch, Imperial and Reliance trucks, last week took on two additional agencies, the Rauch & Lang electrics and the Oakland.

C. F. Splitdorf, the well-known manufacturer of ignition specialties, has just opened a branch in Chicago. It is established in a well-appointed and commodious quarters at 310 Michigan avenue and a full line of the Splitdorf products will be constantly carried in stock for quick delivery. B. P. Houlihan, who for some years has been manager of this firm's branch in San Francisco, and who is well known to the trade throughout the country, will have charge of the new branch.

The interests of the H. W. Johns Manville Company in Detroit and adjacent territory, having increased to an extent where the business can no longer be properly attended to otherwise, a new branch house will be established there. It will be located at 72 Jefferson street, and will be under the management of Willard K. Bush, who has been connected with the Milwaukee branch of the same house for a number of years. Complete stocks will be carried at the new Detroit branch.

An important change in the agency forces along Broadway took place last week in the placing of the Acme line with the new firm of Cordner & Flinn, which has established headquarters at the northeast corner, of Seventy-sixth street and Broadway. The concern is a recently-formed partnership between A. B. Cordner, long and favorably known in the life insurance field, and Welton H. Flinn, who has been representing the makers of the Acme in New York for some months past. The agency was formerly with J. B. Brewster & Company.

### PERSONAL TRADE MENTION.

R. B. Mann, until recently connected with the White branch in Orange, N. J., has been added to the sales force of the Philadelphia branch of the White Company.

The Hamilton Auto Company, Philadelphia, agents for the Stoddard-Davton, last week secured the services of R. Y. Spare, formerly connected with the sales department of the Thomas agency there.

C. F. Green has acquired the auto top factory of the Automobile Equipment Company, and has severed his connection with that concern, combining his interests with the Motor Specialty Company, 239 Jefferson avenue, Detroit, Mich.

F. M. Germane, formerly located in Chicago, as western representative of the Standard Roller Bearing Company, has just been appointed sales manager of that concern, with headquarters at the factory in Philadelphia, where he has been located for the past 18 months.

Charles F. Barrett, formerly assistant engineer of the Electric Vehicle Company, Hartford, Conn., has joined the selling forces of the Locomobile Company, Bridgeport, Conn., and for a time, at least, will devote his energies to handling the product of that company in Hartford. Mr. Barrett finished the 1906 Glidden tour with a perfect score in a 24-horsepower Columbia, and won the class event in the Crawford Notch hill-climb.

Ernest H. Brandt, who has been identified with the Corbin Motor Vehicle Corporation, New Britain, Conn., for some time, as sales manager, has just been appointed general eastern manager for the Cadillac Motor Car Company. Eastern in this connection means New York, New England and New Jersey, as well as the cities of Philadelphia, Baltimore and Washington. Headquarters will naturally be in New York City, and it is understood that the salesrooms will be located in the vicinity of the Circle, at Fifty-ninth street. Previous to his connection with the Corbin interests, Mr. Brandt was with the Hartford Rubber Works Company and was associated with E. R. Berson, the new general sales manager of the Cadillac company.

INFORMATION FOR AUTO USERS

**Hagstrom Blow Out Patch.**—This is a device especially designed for the road repairing of rim cuts and blow outs, that is being placed on the market by the Hagstrom Brothers Manufacturing Company, Lindsburg, Kan. It is in the form of a sleeve and when applied to a tire that has been worn past the danger point, will effectively prevent a blow out. It is made of five layers of high-grade friction fabric and covered with a good quality of rubber, made amply strong to protect a blow out, or rim cut, several inches long. It takes

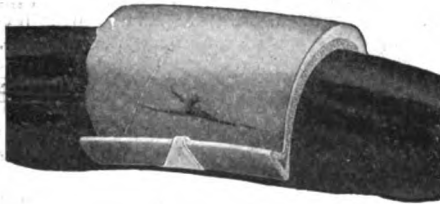

HOW THE HAGSTROM PATCH IS APPLIED.

the strain off the casing and prevents the tire from bulging out of shape, so that ordinary rim cuts and blow outs can scarcely be noticed, when repaired with the aid of the Hagstrom blow out patch. The patent metal clips are formed longitudinally to correspond with the radius of the shoe, with a tongue bend round the bead of the shoe, making the patch a permanent fixture, thus saving the inner tube when the shoe gives out. They are made to fit all sizes of shoes, and for the clincher, Dunlap and Fisk styles, as well as for all detachable rims. While giving protection to the inner tube, the patch itself is protected by the shoe and may be used any number of times.

**Atwater Kent Spark Generator.**—The success with which this piece of ignition apparatus has met, particularly in connection with dry cells and other forms of battery, is due to the instantaneous and positive primary contact. The mechanism by which this is accomplished is extremely simple and ingenious, and very positive in

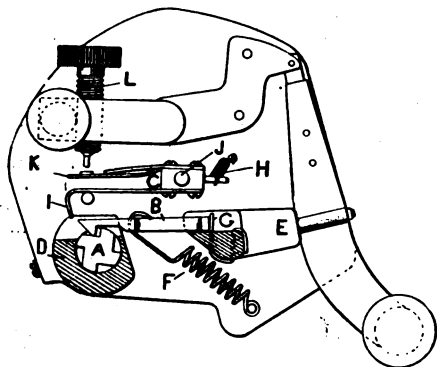

PLAN VIEW, ATWATER KENT CONTACT MAKER.

action. The illustration shows a plan view of this contact maker, the moving parts being the shaft *A*, the snapper *B*, and the pivoted contact arm *C*. The shaft carries four, or for a six-cylinder engine, six milled notches, forming a ratchet which engages the claw at the end of the snapper. The latter is a light piece of tempered steel, which is guided by slots in the bronze base *DE*, and is pulled by the spring *F*, against a spring wire stop *G*, when released from engagement with the notches on the

shaft. The contact arm *C*, is likewise held normally in the position shown, by the tension of the spring *H*. The shaft, turning counter clockwise, draws the snapper into position, and the claw of the snapper, when released, rides up on the rounded part of the shaft, acting thereby as a wedge between it, and the steel hook *I*, of the contact arm, which is pivoted at *J*. The contact arm is thus oscillated to produce contact between a platinum point in the flat copper spring *K*, and the stationary insulated contact screw *L*. A special feature of the peculiar form of contact maker described is the fact that backward rotation produces no spark at all, which is an advantage in connection with a two-cycle motor, to prevent its reversing. The Atwater Kent Spark Generator is made by the Atwater Kent Manufacturing Works, 46 North Sixth street, Philadelphia, Pa.

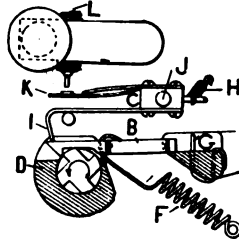

DETAILS, ATWATER KENT CONTACT MAKER.

**Electric Tail Light.**—This is a novel electric lamp designed to aid the autoist in carrying out those provisions of the laws to be found in most of the States, which provide that the rear number be illuminated at night. That the average tail lamp falls far short of complying with this requirement may be seen at a glance at the ma-



ELECTRIC TAIL LIGHT FROM BOSTON.

jority of cars. This newcomer is manufactured by Holt & Beebe, 40 Sudbury street, Boston, Mass., and is designed to be attached either to the number plate, or to the body of the car. It is intended to be supplied with the necessary current from the sparking battery of the car. The light is thrown directly on the number and has the great advantage of not being shaken or blown out.

**Decarbonizer.**—To meet the constantly growing demand for some substance which would remove carbon deposits from the combustion chambers of a motor without the necessity of dismantling it, the General Accumulator & Battery Company, Milwaukee, Wis., has placed a compound known as "Decarbonizer" on the market. It is an oily substance mixed with chemicals that will combine with the carbon, and with the aid of the combustion in the cylinder, which volatilizes it, carries the carbon out

through the exhaust, leaving the piston, rings and cylinder perfectly clean and in a well-lubricated condition. The engine should be hot before using the Decarbonizer, and the oil should be shut off three to five minutes before injecting it, in order that the carbon deposits may be dry and the Decarbonizer soak into them. Two to three ounces should be put in each cylinder and the engine run until excessive smoking ceases. The exhaust valve must be closed when injecting the Decarbonizer or it will be forced out when turning the engine over to start. It will continue to act for hours after, or as long as there is any carbon in the cylinder. The makers guarantee it to be absolutely harmless when used in connection with gas and gasoline engines, also that a thorough cleaning of the working parts can be effected in 15 minutes.

**Ackerman Parting Windshield.**—This is a new type of windshield manufactured by Joseph N. Smith & Company, Fourth and Porter streets, Detroit, Mich., and which has numerous advantages over the ordinary style. It is designed to be operated from the seat of the car and may be raised or lowered in five seconds, locking securely in either position, and without any possibility of rattling. The top sash is hinged by the upper braces, preventing any

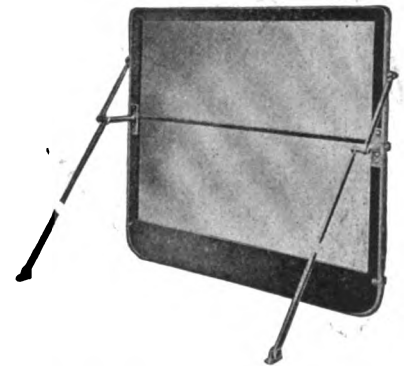

LINE OF THE ACKERMAN WINDSHIELD.

possibility of being detached, or dropping accidentally. It requires but four inches space to operate in and will thus avoid the lamps or steering wheel on any car. The braces are constructed with universal joints and are arranged so that they can be cut to any desired length. There are no projecting arms or handles to mar the beauty of the shield, while the bottom sash is made five inches wide, so as to allow for cutting to fit the shape of the dash without the use of any filler board. This construction reduces the possibility of accident to a minimum as no metal comes in contact with the glass, the channels across the center being padded to receive it. It is made regularly in 42 and 45-inch widths, special brackets being supplied according to whether the shield is desired for wood or metal dash. The same makers also manufacture coat and foot rails.

**"Fillem" Tire Repair.**—This is a substance designed to repair cuts, punctures, curb injuries, sand blisters and the like, to pneumatic tires, and is being placed on the market by the Greenwald Rubber Company, 31 Church street, Buffalo, N. Y. Neglecting these injuries to a tire allows water and sand to work through the plies and eventually causes the tread to separate from the fabric, thus ruining the tire. It would mean considerable expense and time to remove a tire to have it vulcanized every time it suffered damage of this kind, and the average autoist simply lets it go, thus

making the time when the tire needs re-treading, far shorter than it would be if this damage were tended to in time. To use, it is only necessary to remove all foreign matter from the cut, cleaning it out well with gasoline with the aid of a piece of muslin and a pair of tweezers. A piece of "Filler" of the required size is then forced into the opening and the repair trimmed smooth with the wet blade of a knife.

**Whitney Chain Belt.**—This is a special type of belt designed to be employed in connection with cooling fans, oilers, for driving motorcycles and also for many purposes in connection with machinery where a high speed round small pulleys is required to be noiseless and positive. As will be apparent from the illustration, the chain is composed of center blocks, rivets and special side links, while a piece of leather of special shape is wrapped round each pair of side links and is held firmly in place by means of a steel plate on the top surface of the leather, the plate being held

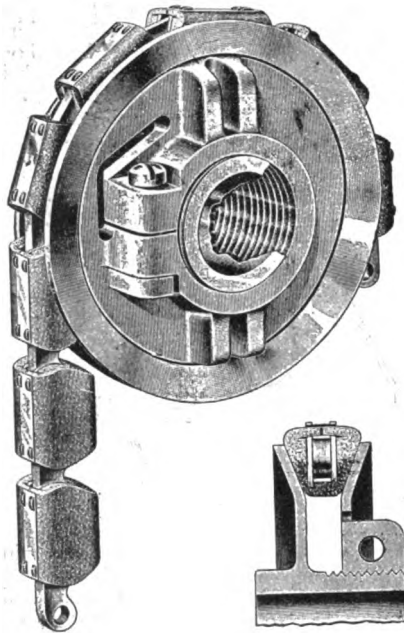

DETAILS OF THE WHITNEY CHAIN BELT.

by projections on the side plates of the chain, which pass through the locking plate and are headed over against it. The locking plate has teeth on each side which are imbedded in the leather in order to hold the ends securely together. Nothing but the leather comes in contact with the grooved pulleys, but the chain center makes the belt absolutely flexible, even when running round a pulley of small diameter, and it prevents the belt from stretching. By means of the adjustable pulley, the chain belt may be stretched to the exact tension required without the use of an idler, and also without an adjustment between the centers of the pulleys. The flanges of the adjustable pulley are brought together to tighten the chain and when they are separated, the chain will loosen. An absolutely noiseless and positive drive is insured. Several prominent automobile builders are now trying out the Whitney chain belt on their cars with excellent results.

**Slama Tire Protector.**—This is a new type of steel tire protector and non-skid device that is being manufactured and marketed by the Slama Tire Protector Company, 609 East Fifteenth street, Kansas

City, Mo. It is made of steel links of special formation, as will be seen by the accompanying illustration showing it in place on a tire, and is complete in one piece, the fastening consisting of a single hook. It is primarily intended for continuous service, only the broad, smooth backs of the



SLAMA TIRE PROTECTOR IN PLACE.

crosses, or links, coming in contact with the rubber of the tread, but it is easily attached or removed and can be rolled into comparatively small compass to stow in the tool box. It is adjustable to fit all makes and sizes of tires.

**Palmer Heavy Truck Tire.**—This is the invention of H. A. Palmer, Akron, O., who has had a number of years' experience in the manufacture of both solid and pneumatic tires, and is designed to do away with the disadvantages at present existing in the one piece type of solid tire for commercial vehicle use. The new Palmer tire is made in annular sections with transverse holes molded near the base, and in which the cross rods are inserted when the tire is applied. This is shown by the sectional illustration. Between each rubber section, and over, or above, the cross rods, is a circumferential wire ring. On each surface of the side flanges, recesses are provided to engage the cross rods in order to prevent creeping, the circumferential rings, holding the tire in place and preventing any outward movement. While in use under heavy loads, the cross rods move slightly with the rubber, both to and from the wheel base, as well as circumferentially, which prevents the rubber wearing away from the cross rods. To apply the tire, one flange is placed on the wheel and held in position with several felloe bolts; the wheel is then laid flat on trusses, or blocks, with the flange underneath the wheel; a section of rubber is then put on and the cross rods inserted, then a circumferential wire ring and alternate rubber section and wire ring, until the proper width is obtained. The other flange is then placed in position and bolted securely. Should a section or part section become damaged, it may readily be replaced by removing one of the side flanges, the operation being very simple and easy.

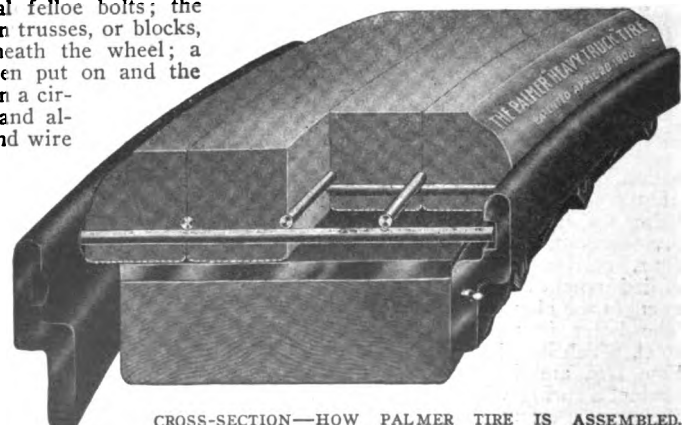

CROSS-SECTION—HOW PALMER TIRE IS ASSEMBLED.

**Acme Roadster.**—This is one of the latest additions to the constantly increasing number of buggy type cars being turned out in the West. It is the product of the Motor Buggy Manufacturing Company, 309 South Third street, Minneapolis, Minn. The power plant consists of a two-cylinder vertical, water-cooled four-cycle motor, of 4 1-2-inch bore by 4-inch stroke, rated at 16 horsepower. Jump spark ignition using batteries is employed, while an option of the Schebler or Heitger carburetors is offered. The radiator is built of brass tubes surrounded with copper fins. The change speed gear is of the planetary type giving two forward speeds and reverse, while the drive is by means of double chains, Hyatt roller-bearings being used on the counter shaft and transmission, while Timken roller-bearings are used on the wheels. The frame is made of 1-4 by 1 3-4-inch angle steel and the body of white wood on oak sills. Speeds of from one to 25 miles an hour are possible as the car only weighs 1,300 pounds. The wheelbase is 86 inches and the tread standard.

The advent of the new Acme Roadster marks a return to the two-cylinder vertical type of four-cycle motor that has been so largely used abroad, but which has come in for comparatively slight attention at the hands of American makers.

**Ze-nole.**—This is an up-to-date cleaner for auto tops and slip linings, that is manufactured and marketed by F. S. Carr, 74 Pearl street, Boston, Mass. It will remove all spots caused by dust, rain or mud, as well as grease spots, and keeps a top in good shape merely with a few minutes regular attention. It can be freely used, as it has no injurious effect on the rubber compound. Mr. Carr is also an importer of auto top materials and handles a line of domestic fabrics for this purpose in addition. Experience has taught that macintosh material is the most artistic and most practical cloth for this purpose, being made in a wide variety of shades to harmonize with the finish of the car. Complete lines of samples of both foreign and domestic materials will be sent to makers or owners by Mr. Carr on request.

**Miller & Starr Grease Gun.**—In the description of the "quick acting" grease gun which recently appeared in these columns, the makers, Miller & Starr, call attention to the fact that it was erroneously stated that the gun is filled by removing the cap, whereas it should have been said that this was done by unscrewing the nozzle from the barrel. The barrel should then be pushed into the grease gradually, turning the handle from right to left. The makers further state that it would be impossible to unscrew the cap as directed, without breaking the lugs in it, thus damaging the gun.

# THE AUTOMOBILE

## ALCOHOL FUEL IN FRENCH INDUSTRIAL VEHICLE TOUR

By W. F. BRADLEY.

PARIS, May 15.—The military element is strong in the industrial vehicle competition, which the Automobile Club of France has put on foot for the fourth year in succession, and which is now being carried out in the north of France. After a couple of days for weighing in and sealing of parts, Sunday was spent in the Galerie des Machines under the gaze of a numerous public. Promptly at 7 o'clock each team was admitted, at intervals of five minutes, to enter the enclosure and take out

make their controls with perfect regularity, speeding to gain time as a reserve for a breakdown being impossible, owing to numerous sub-controls on each of the stages. An innovation in competitions of this nature is that the changing of tires, rims, or wheels is forbidden. Pneumatics are not allowed except in the cab section, and for those vehicles desiring to compete for the military prizes, or to be bought by the army at the end of the competition, the rear wheels must be shod with steel.



Two of the Ponderous Trucks Proceeding on Their Official Way Over the Course Near Bonnieres.

a vehicle, running time being counted from the moment the order was given to enter the parking place. A stop of one minute at the gate of the big hall to allow the military officer to throw up his meager baggage and climb on board, and the car was off for its month's journey.

In addition to covering 1,885 or 2,488 miles, according to the type of vehicle, each competitor must make every control on time, must change none but the parts allowed by the committee, and must finally submit to a fuel test for final classification. There is nothing in the nature of a pleasure excursion in this competition, the vehicles being required to carry their full load for one month, a condition never demanded in actual work, and to

Gasoline is the fuel used by all the trucks, but all those competing for the army prizes must be capable of running on alcohol, and must, on the last stage of the journey, cover a distance of approximately 100 miles with this fuel. The club regulations under which all cars finishing the regularity test must submit to a final fuel test, leaves the choice of fuel to the individual constructor, on condition that he makes known his choice fifteen days in advance.

### Vehicles Must be Capable of Service Without Rubber Tires.

Compared with previous years, the thirty-four trucks and eleven cabs taking part in the two competitions are a specially



good set. There are practically no cases of touring car chassis fitted with special bodies and strengthened in a few features, but in almost every case the vehicles are specially designed and studied for the work they have to perform. One of the most significant features of the competition is that neither wheels nor tires can be changed, and that, to meet the military requirements, the rear wheels must be steel shod. For the commercial vehicle to become a serious factor in the field which it seeks to occupy, it is imperative that the hitherto enormous expense attending the use of pneumatic or rubber tires must be reduced in no small proportion. In previous competitions, wheels and tires have been the weakest point in all the vehicles, the number of those showing economical results in these two features being very small. The new regulation has had as a first result the more serious attention to suspension. Not only are the springs better adapted to the work they have to perform, but they are on 90 per cent. of the vehicles supplemented with hydraulic or other types of shock absorbers, fitted with grease caps, and have all joints that are securely protected by good leather casing.

For the three lower categories in the light-weight class, the maximum load of which is 3,300 pounds, solid tires front and rear are invariably employed. A couple of tricars for quick delivery service, fitted with a special type of cushion tire cannot be considered as an exception. Where loads of more than 3,300 pounds are carried, the majority of the competitors have adopted metal-shod wheels for the rear and solid rubber tires in front, in accordance with the military requirements. It is a foregone conclusion that a certain number of these will be unable to come through the test, the suspension being manifestly inadequate for steel rims. An insignificant proportion have ignored the military conditions and fitted solid rubber tires in the rear. In consequence of the general use of steel tires, a large proportion of the competitors in the heavier classes have fitted sand boxes automatically laying a trail of sand before the rear wheels at the will of the driver.

In the two classes of passenger vehicles, the lower one, with provision for 6 to 10, and the higher for more than 10 persons, excluding the driver, solid rubber tires both front and rear are found on every vehicle, one or two employing twin tires for the rear.

Mechanically considered, there is a certain similarity in the French vehicles engaged in the trials. There are all the differences one would expect to find among a group of vehicles varying from one-lungers of 3.3 by 3.5 bore and stroke to powerful four-cylinder of 5.6 square; but general lines of construction are observed throughout the different classes. There is not a single steamer in the competition, the only two firms of importance in France devoted to this class of automobile having refused to engage cars. Without exception, the engines are vertical and water-cooled, the pump being employed on all but a three-ton Berliet and Cohendet. Ignition by high-tension magneto is in the majority, the low-tension type being employed on not more than 20 per cent. of the cars. Transmission in all cases is by sliding gear, but clutch and drive show a diversity of systems.

Though final drive by side chains is general in the heavier vehicles, there are a small number of vehicles with cardan shaft and double rear axle of the De Dion type. Direct drive on both third and fourth speed is reserved to the numerous Ber-

liet vehicles. Panhard and Saurer, the Swiss commercial vehicle constructor, use the engine for braking by means of a camshaft movable at will.

#### Taxicabs to Cover 2,500 Miles on Alcohol Only.

Particular interest attaches to the taxicabs from the fact that it is the first time vehicles of this nature have been put to a severe public test, and also on account of the use of alcohol as fuel for a journey of nearly 2,500 miles. There are five 4-cylinder engines, the average dimensions of which are 2.9 by 4.7 bore and stroke; three 2-cylinder cars and a solitary one-lunger. Excepting a couple of Brasiers, all the cabs have high tension-magneto only, storage batteries not being carried. Thermo-syphon and mechanical water circulation are in the proportion of six to five. The classic leather face cone clutch is supreme, being fitted to all but one of the competing cars. Cardan shaft is employed without exception, but there is no uniformity in the type of gear boxes or their position, some of the makers uniting it with the differential on the rear axle, and others carrying it in the more general position between the engine

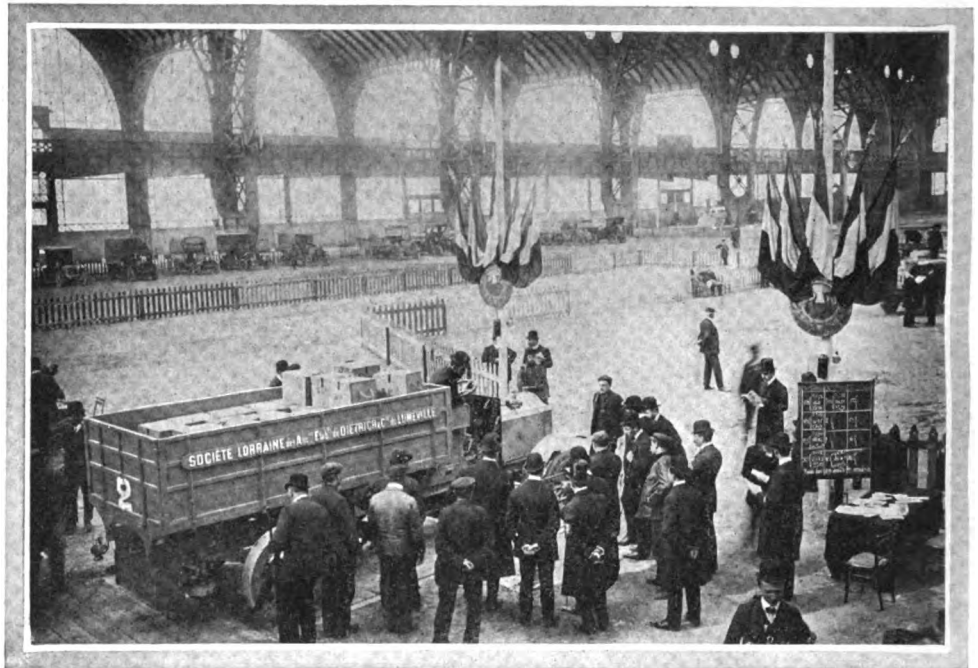

Where Cars Were Weighed In, Sealed, and Started on Their Long Journey.

and the shaft. With tires, and complete with closed body, lanterns, and all accessories, the price of the taxicabs varies from \$1,200 for the 9-horsepower one-lunger to \$1,700 for the 12-horsepower four-cylinder Vinot. Bayard-Clement turns out a two-cylinder at \$1,200 complete, and two other firms with a good reputation produce a four-cylinder cab at \$1,600.

#### Minister of War Will Buy at Tour's Conclusion.

The Minister of War has sent an official delegation to follow the vehicles in their wanderings, and has announced his intention of buying some of the most successful automobiles at the end of the competition, in accordance with a now well-established practice. The Russian military department has also sent an official delegation and will purchase thirty trucks for army transport service.

The order of travel has been modeled somewhat on the lines of that adopted in the very successful English commercial vehicle trials of last year. Starting from Paris, the procession will first make its way to Rouen, two different routes being adopted, a shorter one for the slow-moving wagons, and a more circuitous one for the fast-moving vehicles. Rouen, Amiens, Lille, Reims, Nancy and Dijon, all being towns of considerable commercial importance, will be encircled by the competing vehicles in such

a way that the cars will pass from two to four nights in these centers and give the inhabitants an opportunity of closely inspecting them. Throughout the month's run the slow vehicles will shortly be given the shortest distance from point to point, but the meeting place every evening will be the same for all.

**Types That Are Engaged in Competition.**

Only one of the classes provided by the technical committee failed to draw entries, that for automobile trains of the Renard type in France, and the Alden-Sampson in America. In the light class reserved to vehicles carrying from 110 to 440 pounds the three entries consist of a couple of Contal tricar and a Werner light delivery vehicle. Panhard and Peugeot are alone with one vehicle each in the second category, while the third class is limited to three cars supplied by Panhard, Brouhot, and Dietrich. A better show is made in the 3,300 to 4,400 pound class, where there are two Berliets, two Peugeots, a De Dion and a Vinot. In the fifth class for vehicles carrying a load of 4,400 to 6,600 pounds, Berliet again has two vehicles, and Saurer, Panhard, and De Dion one each. There is the best representation in the sixth class for trucks transporting loads of more than three tons, the entries being two front-drive Latil trucks, two Cohendets, two De Dions, two Berliets, a Dietrich, a Saurer, and an Espine, Achard & Co.

Two classes are provided for light omnibuses intended to be used for hotel service, for holiday resorts, or for surface car feeders, where the number of passengers will be relatively small and rate of travel high. Six vehicles capable of carrying from six to ten passengers are supplied by Berliet, Peugeot, De Dion and Dietrich. The last class for omnibus carrying more than ten passengers has united but two engagements, one from Dietrich, the other from Saurer.

**Chief Interest in Taxicab Section.**

Undoubtedly the chief interest of the test lies in the taxicab section organized for the first time in France. In adopting alcohol as the fuel for these small vehicles the organizers have doubtless had in view local conditions, alcohol being slightly more advantageous in the city of Paris than gasoline, owing to the town duty on the latter.

Two cab classes are provided, one for small vehicles with a single-cylinder engine of not more than 3.9 inch bore and a minimum weight of 2,200 pounds, and the other for four-cylinder engines of 3.1 inch bore weighing 3,300 pounds. The former are intended to carry two passengers only, without baggage, and to prove a direct rival of the light horse cabs of Paris. In the larger class four passengers have to be provided for and some space given for baggage, this section being intended to encourage cabs for railroad and hotel work, with passengers always accompanied by a certain amount of baggage.

All essential parts of the cars were sealed before leaving Paris, so that no parts can be changed without the knowledge of the official observer on board. Each night vehicles will be stored in a closed garage or open park protected by the police or troops, so that no changes can be made surreptitiously, and at the end of the run, just before entering Paris again, a fuel consumption test will be held.

**EFFECT OF SHADE TREES ON FRENCH ROADS.**

In answer to inquiries from the United States, Consul-General Robert P. Skinner, of Marseille, furnishes the following information relative to the effect of wayside trees on French roads:

"It is proposed to plant trees along the roadsides of New York State in order to keep the moisture in the road and prevent raveling, and the question has been raised whether or not the roots of such trees may spread out underneath the road surface, and eventually create great damage in a severe climate where there are extremes of heat and cold. While French roads are not always bordered with shade trees, they are so very frequently, and my information is that the trees are planted not only for furnishing shade, but in order to protect the roads themselves against the effects of excessive heat and drought. It is believed that the long, dry summer season is much more inimical



Brouhot Taxicab on the Road Near d'Abbeyville.

to roads than severe cold. The chief officer in charge of the public roads in Marseille is of the opinion that, on the whole, New York roads would be benefited if bordered with trees, suggesting, however, that only such should be planted as have vertically descending roots."

**FLYERS DO NOT LIKE ENTRY FEE TAX.**

PARIS, May 15.—Aeronauts are not pleased at being obliged to pay an entry fee of \$10 twenty-four hours in advance of each attempt to win one of the many flying prizes. If the prize is won the fee is returned, but if for any cause whatever the aeronaut falls short the money is retained. Delagrangé, Farman and others ask that when rain, wind, or other natural causes prevent a flight, the engagement fee should be returned.



Berliet Omnibus Completing Its Road Test.

## PARIS BOULEVARD PROVES ROAD-WEARING ECONOMY OF AUTO

PARIS, May 14.—It is doubtful if Paris possesses more automobiles than New York or London, but there is no doubt whatever that the western portions of the French capital have a more intense automobile circulation than any city in the world. It was hardly necessary to search for official figures to be convinced that in the richer residential quarters of the city automobiles are almost as numerous as horse-drawn vehicles. But the Paris police have gone into the subject, and have compiled an official table, the accuracy of which cannot be doubted, showing to what extent traffic has increased since 1881, and what proportion the automobile holds in street circulation. It will be seen that the proportion is nearly equal.

At four different spots in the city policemen were stationed from 3 to 7 in the afternoon of seven consecutive days with a mission to count the number of vehicles passing their post. On a Saturday afternoon in February the following figures were obtained in the Avenue des Champs-Elysées, the main artery of Paris, and one forbidden to surface cars and heavy commercial vehicles, so that the statistics refer particularly to pleasure cars:

Automobiles .....	3,430
Various horse vehicles .....	3,695
Automobile 'buses .....	34
Horse 'buses .....	81
<b>Total .....</b>	<b>7,240</b>

Horses are thus still in a majority, even in the most favored quarter of Paris, though the difference is so small that it is safe to prophesy a change in favor of the automobile at no distant date. The figures were not taken at a time when automobile traction is at its greatest intensity, a cold, damp Saturday afternoon in February not being the day when the maximum of pleasure vehicles are on the streets. Had the census being taken in early June, when Paris is invaded by its thousands of pleasure-seeking visitors, there is no doubt that the horse would have shown a decided minority.

Owing to the intense automobile traffic of the Champs-Elysées, the Paris Police a year ago issued a new regulation, dividing the four-footed traction from the horseless variety. The Champs-Elysées is divided into three distinct channels by reason of a double row of electric light standards and refuges at frequent intervals. The central avenue, between the refuges, is now reserved exclusively to both up and down-going automobiles, the two sides are sacred to the horse, the bicycle, the push cart and other slow modes of locomotion, one side being for up and the other for down traffic.

More benefits have accrued from the innovation than were ever thought possible by Prefect of Police Lepine. The pleasure of driving in an avenue from which all slower modes of traffic are barred can only be fully realized by those who have attempted to wade their tortuous way through the miscellaneous and crowded streets of the city and have then entered into the automobile row of the Champs-Elysées. A very much higher speed is maintained than is possible on the two side sections, yet accidents are fewer than among the horses, and the congestion of the avenue is considerably relieved.



The Imposing Arc de Triomphe.

A unique comparison is made possible in the wear on roadway under horse and automobile traffic. For twelve months horses have had exclusive use of the two sides of the wood-paved Champs-Elysées, and for the same period the automobile has run up and down the central channel. The only apparent change in this latter is that from a dark brown color it has changed to black. The horse section, on the other hand, has retained its primitive color, but has sunk irregularly and become pitted in a thousand places under the influence of steel-shod hoofs. No better example could be found

of the economy in road wear possible by the use of the automobile. The municipality of Paris would do well to divide the macadam-built Avenue du Bois de Boulogne in the same way, in order to prove whether the results on wood would be the same on macadam.

A striking feature of the automobile section of the Champs-Elysées is that the road is not blackened equally, but in two broad lines, the right-hand or up section being very much darker than the down line. The reason for this is doubtless that the avenue is on a slight grade, and drivers of cars generally accelerate and give a little more oil than when running on the level. On the down side the engines are run with very little gas and the minimum of oil, and there is also rather less friction at the wheels. The difference between the two sides is so great as to immediately arrest the attention of anyone seeing it for the first time.

According to official returns, there are 40,000 autos in use in the whole of France, 7,670 belonging to Paris and the Department of the Seine. In this case, however, official figures are misleading, the actual number being very close to 10,000. The large companies possess 1,550 automobile taxicabs, small liverymen are responsible for 398 of the same class of vehicle, the private automobiles in use in the city are generally estimated at 7,000, thus giving a total of 9,835. This does not take into consideration the auto-buses run by the municipality, and now numbering about 100, nor the commercial automobiles.

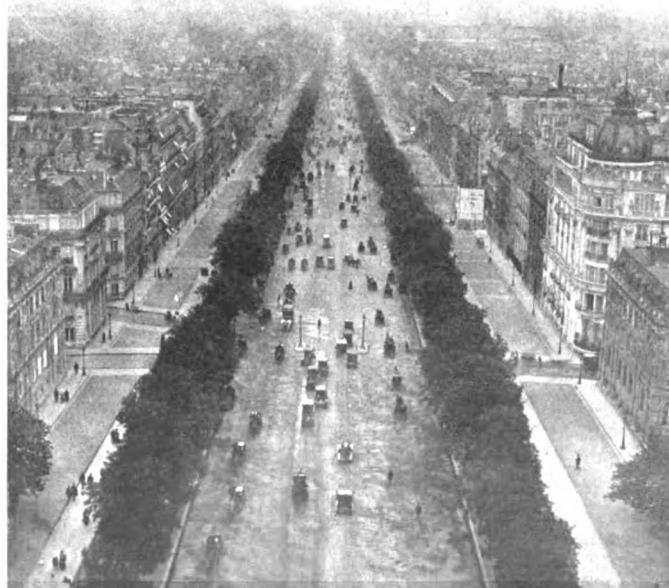

How the Traffic is Regulated on the Champs-Elysées.



A Fine Macadam Stretch and a Good Illustration of the Scenic Connecticut Country Traversed In the Endurance Run.

## CONNECTICUT ENDURANCE RUN HAD PERFECT SCORES

HARTFORD, CONN., May 16.—The initial endurance run of the Automobile Club of Hartford was a most successful consummation, viewed from every standpoint. It is doubtful if ever a club committee worked harder for the good of a common cause. Other cities than Hartford were well represented—even Massachusetts sent down a few cars.

All day long, and to-night, in the immediate vicinity of the club quarters in the Allyn House, there were muffled roars of occasional cars running in without a muffler or making use of the cut-out, which, by the way, is not as yet a serious offense in the capital city of the Nutmeg State. Positions in the event were drawn for on Thursday evening. Friday bespoke of rain, but to-day was ushered in with blue sky and sunshine. Long before the time for the official start, the cars lined up along Trumbull street, and as the whistles tooted the advent of another working day the first car went its way amid a din of applause. The remaining cars were sent away at two-minute intervals, and they literally had to pass down a long lane of spectators to the turning point at Trumbull street, where the local police kept the road clear.

### Who They Were and How They Got Away.

To Robert R. Ashwell, in a Franklin, went the distinction of being No. 1, and to Philip Corbin, Jr., went position No. 2, his car being a little air-cooled Corbin. Joe Matson was third, in another car of the same make, and Louis Elmer crossed the line in a little Ford four-cylinder runabout. Pete Robinson, in a six-cylinder Stevens-Duryea, was fifth, and R. L. Lockwood was the next to get away in the 18-horsepower Reo runabout. Harry Tuttle, of New Haven, was next in line, with a 15-horsepower Stoddard-Dayton runabout.

V. A. Charles, the Bostonian from the Rambler branch "along the row," was next in a 32-horsepower Rambler. F. E. Bowers, of New Haven, started tenth, in another Rambler runabout of 40-horsepower, and he was followed by still another car of the same make, driven by Harry Turrell, of Waterbury. S. A. Miner, the local Knox representative, was the next to start, and was followed by his son, Bob, in the little two-cylinder Buick, and the junior member of the family was somewhat wary for

the reason that he drove under No. 13. As a matter of course, he carried a horseshoe over the muffler, also the number "13" in large nickel letters. A. Lazarro, Jr., started fourteenth, in the three-cylinder Compound, followed by C. M. Wright, in the Stoddard-Dayton.

F. W. Dart, a member of the contest committee, was the next starter, and, in order that he might participate with a free conscience, he resigned two days before the contest. To him went one of the hardest pieces of luck of the entire day, for just as he received the word go he accidentally stalled his motor. The car had barely passed over the line, but was penalized one point. He drove a 48-horsepower Thomas Flyer, and carried about the largest number of passengers of any car in the run, and lost not a point throughout the contest thereafter.

The 22-horsepower Overland was the next starter, driven by the local agent, A. W. Peard. S. W. Hancock was another of the Bay Staters who journeyed down to Connecticut looking for glory, and he got it, as later statements prove. G. W. Bennett, of the New York White branch, was the next, with a White steamer. He went his way in good order, made a good showing along the road to the next control, but was penalized for arrival ahead of schedule time. Frank Dunnell, another New Yorker, followed the departed ones in a Ford "Six," followed in turn by B. F. Smith, the local representative of the Mitchell, in a 35-horsepower car of that make. S. E. Campbell, of New Haven, another of the Rambler contingent, faced the starter, and, at the word "go," drove peacefully along the way to a good score.

Hal K. Sheridan, who was regarded as one of the likeliest in the contest, was next in order in the White steamer, but Hal, through no fault of his own, was a victim of fate, like many another, before the day was done. Harold Green was next in order, with D. J. Post's Pope-Hartford, followed by Ariel Mictelson, in a four-cylinder Cadillac, another victim of fate. Dean Rankin drove A. E. Bradley's Peerless runabout, followed by C. P. Hulst, in an Oldsmobile of 36-horsepower. T. F. Garvan came next, in another 30-horsepower Pope-Hartford. J. F. Corbett, of New Britain, was next, in a Corbin of 24-horsepower. J. W. Lynch drove a 30-horsepower Knox, followed two minutes later by Stanley Goss, of New Britain, in a





Two-cycle Atlas Nearing Top of Plymouth Hill.

Corbin. John Coffey was the next starter, in C. D. Alton's 29-horsepower Columbia runabout.

A Thomas-Detroit, driven by Oliver Light, followed, and J. B. Burrall left on time in a Packard "30," one of the most consistent running cars in the contest. John Leitz came next, in the smallest car in the event, the single-cylinder Cadillac, made the first round without a tremor, and in all of the second but about ten miles, was pursued by a streak of hard luck that put it hopelessly out of the honor class. Another six-cylinder car, W. H. Hall's Pierce runabout, driven by D. C. Lull, was next, followed by A. B. Barkman, of Tarrytown, in a 24-horsepower Maxwell.

President J. D. Anderson, of the Hartford Rubber Works Company, was next in order, in a Thomas Flyer, which carried a full load of jolly passengers, bent on getting all the fun there was to be had in the 174-mile joy ride. Another consistent car was the two-cycle 22-horsepower Atlas, driven by F. W. Ruggles. William Burr, who is remembered as a factor in the club hill-climb of last September, was in evidence in a 30-horsepower Knox.

The Hon. H. R. Coffin, a free bridge advocate for the towns along the Connecticut where one now pays toll, drove his own 45-horsepower Columbia, and did the trick to perfection. Another Mitchell, driven by Frank Zerbes, trailed the Columbia, to be followed in turn by Claude Pinney, of Stafford Springs, in a 28-horsepower Maxwell. J. M. Macdonald, a local driver, handled the two-cylinder Maxwell in next position, and was



Perfect Score Rambler Checking at Hartford Control.

followed by F. W. Belcher, in the 40-horsepower Locomobile of the Fisk Rubber Company. The last in the long line was Gregory S. Bryan, of Bridgeport, in a 36-horsepower Oldsmobile runabout.

Some of the Troubles That Spoiled Scores.

Before the last car had started, news of the forerunners was coming in, and it was learned that G. W. Bennett had been penalized in the White steamer as above mentioned. The Reo had trouble with gears and withdrew, and the Compound was unheard of after Middletown. Truly this contest had the claim to the term endurance, for the cars had no small problem to gain their perfect score. With all the cars under way, the Hartford control took things easy, and prepared for the arrival after the first round. Promptly on time, Bob Ashwell, in the Franklin, came around the corner at a stiff gait, only to suffer a blow-out, which cost him eight points, thereby killing his chances of a perfect score. The remaining cars trooped in, one after another, with now and then one back out of place. The Overland had radiator and tire troubles; Hal Sheridan ran shy on water, and paid the cost; Bob Miner, in the two-cylinder Buick, found it necessary to look at a spark plug, and was

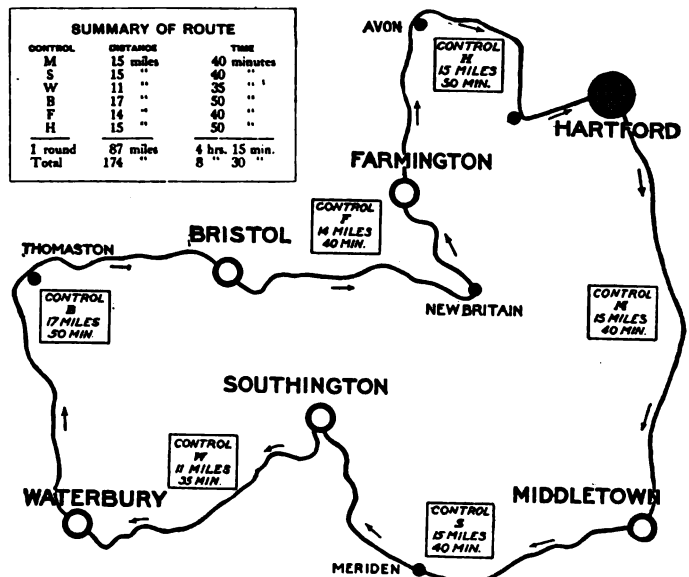

Map of Route of Hartford Endurance Run.

therefore taxed two points. Compound was out of the running, and failed to appear, but the Stevens light "Six," driven by Hancock, came in clean.

No. 22, Mitchell, was disqualified at the Farmington control for running in ahead of time, but continued under protest, to later capture the coveted clean score for the entire run. No. 27, Peerless, had clutch troubles, and tires were troublesome. No. 29, Olds, had tire trouble, and reported accordingly. No. 30, Pope-Hartford, came in on a clean slate; so did No. 31, Corbin. Tires caused all the damage to the chances of No. 12, Knox, for a clean score, and No. 32 was in the same boat. No. 34, Columbia runabout, had ignition troubles on the first control, but ran otherwise clean. On the second round it came to grief. The big Columbia came home clean, but after crossing the line the radiator connections were found to be in bad shape, and one point was checked up because of the attention accordingly bestowed. No. 35, Thomas-Detroit; No. 36, Packard; No. 38, Pierce "Six"; No. 37, single-cylinder Cadillac; No. 39, Maxwell, and No. 40, Thomas Flyer, came in with clean slates. No. 41, Atlas, had slight troubles of the tire description, but No. 42, Knox, came in clear. No. 44, Mitchell, suffered five points, but No. 46 and No. 47, the four and two cylinder Maxwells, respectively, came in clean. No. 48, Locomobile, had a puncture, and to replace a new tire took just a shade more than three minutes, which is going some, and cost four points. No. 49,

Buick, came home with colors flying and a clean score. No. 50, Olds roadster, had a hard session with tires, and came in to the Hartford control later, and was withdrawn. Out of the 47 cars started, the showing thus far was very good.

**That Demand for a Hard Run.**

There had been a big demand for a hard run, and it was given, but the cars stood the racket in good shape. After checking out at the Hartford control, a new observer was placed upon each car, and the oil, water, and gasoline supplies replenished.

All the cars reaching Hartford went away over the second lap in good order. As the time for the arrival of the first car approached, the throng once more lined the street, and were soon rewarded by the appearance of No. 1, Franklin, it having maintained that position throughout the contest. Some who went through the first round safely, as in the case of the Cadillac single-cylinder, were hard hit in the final lap. Ariel Mitchelson, Cadillac, 30-horsepower, arrived at a control before he was due, and was disqualified, so put about for home. The final arrival of cars was more or less of a straggling nature. But there is an end to all things, and soon all cars were present or accounted for.

The committee took a short rest, and announced that the results would be forthcoming in a short time. In the meantime, dinner was awaiting the workers who made this affair notable and a success. Then the observers were gathered together in the large dining hall of the Allyn House, and, after due deliberation, that body voted that the G. K. Dustin observers' cup be awarded to the 18-horsepower Maxwell two-cylinder for the most consistent performance.

Chairman Maxim announced that the following cars had perfect scores:

- |                                      |                           |
|--------------------------------------|---------------------------|
| No. 3 Corbin                         | No. 33 Corbin             |
| No. 5 Stevens-Duryea<br>(light six)  | No. 35 Thomas Detroit     |
| No. 8 Rambler                        | No. 36 Packard "30"       |
| No. 11 Rambler                       | No. 38 Pierce Arrow (six) |
| No. 15 Stoddard-Dayton               | No. 39 Maxwell            |
| No. 19 Stevens-Duryea<br>(light six) | No. 40 Thomas Flyer.      |
| No. 21 Ford (six)                    | No. 42 Knox               |
| No. 22 Mitchell                      | No. 46 Maxwell            |
|                                      | No. 47 Maxwell            |
|                                      | No. 49 Buick              |



Ford Checking In at Country Club, Farmington Control.

Thus out of 47 starters there were 18 perfect score cars, which was rather surprising, for it assuredly was a hard test.

**Winners of the Gasoline Economy Test.**

If entrants so desired, they could participate in the gasoline economy test. The official award gave to the No. 5 Stevens-Duryea (light "six") the honors in the class for cars costing above \$3,000, "Pete" Robinson being the driver. This car traveled the 174 miles with 11 1-2 gallons.

No. 42 Knox, using 8 1-2 gallons, was the most economical of the cars costing from \$1,500 to \$3,000.

While Louis Elmer's four-cylinder Ford runabout, using 9 gallons 3 quarts, is the probable winner of the class of cars selling at less than \$1,500, a protest which the committee has not yet passed upon has been filed by No. 44 Mitchell.

The Hartford Rubber Works trophy for perfect score cars costing under \$1,500 goes to the two-cylinder 14-horsepower Maxim runabout.

A feature of the contest was the fact that all six-cylinder cars entered had perfect scores.



H. K. Sheridan's White Steamer on Top of Southington Mountain—"In the Shade of the Old Apple Tree."

### ALGONQUIN CLIMB POSTPONED AUGUST 14.

CHICAGO, May 19.—The third annual hill-climb of the Chicago Motor Club, scheduled for last Friday at Algonquin, Ill., then postponed to Saturday, and again until to-day, because of adverse weather conditions, finally has been postponed until August 14, when the original card will be put on. Efforts on the part of the club to pull off the event were strenuous. Rain last Thursday caused the first postponement, and Saturday morning, despite the fact it looked like rain, the club tried again, this time getting partly through program. Motorcycle events on Perry Hill run off, and automobile card had been tackled, contestants in the third class being sent up the hill when rain came in torrents. Then postponement taken until to-day, with the understanding if the weather was bad affair would go over until August. There was no change to-day, so every one came home.

Part of card that was contested Saturday showed climb would be record-breaking affair, for nearly all cars improved on last year's time, and Perry Hill record was cracked by G. F. Sulzberger, amateur, in a Stearns Six, who went up in 25 2-4, as against previous best of 26 1-5. Sulzberger was allowed to make his climb between Classes A and B, so he could strip car for free-for-all. In Class A, for motor buggies, No. 5, Klinger, led in percentage, although Bendix, four-cylinder rig, made fastest time—46 2-5. In Class B, for cars, piston area under 50 square inches, Moline made fastest time—37 2-5—while the Brush run-about led in percentage. Three cars had gone up in Class C for cars from 50 to 65 square inches, Wayne, Haynes and Moline. Last-named led in time as well as percentage, scrambling up in 32 2-5.

There were eighty entries in the climb, which is claimed as the world's record, as it exceeded seventy of Fort George and sixty-seven in the last Gaillon hill-climb in France.

### FOR A RACE TO THE PACIFIC AND BACK.

The New York Times, the promoter of the American end of the present New York to Paris contest, now proposes an across-the-continent-and-back endurance stock car race. The idea received much initial encouragement at a meeting of makers, importers and dealers, and some others high up in the sport and industry, held last Friday evening, May 14. In fact, the meeting resulted in the appointment of Jefferson deMont Thompson, A. R. Pardington, and Robert Lee Morrell as a special committee, to suggest rules for the contest.

It is proposed to start the race on August 15, and run it to the Pacific Coast, returning by a different route, so that as many big cities and as much varied territory as possible may be covered. The Times will enlist the cooperation of other papers.

### ISOTTA VICTORIOUS IN TARGA FLORIO.

MILAN, May 18.—Trucco, in an Isotta Fraschini 40-horsepower car, came in victorious in the postponed Targa Florio race, which was put over from last week, owing to a landslide at a point on the course. Fourteen competitors, running in the interest of as many representative European builders, were sent away over the picturesque course in Sicily, but Trucco's victory was decisive, coming in 13 minutes ahead of Lancia, who was second in a Fiat, and making an average speed of close to 75 miles an hour. The car was the same machine in which Trucco won the stock car race over the Padova Bolanenta circuit.

### A LAW OF INTEREST TO GARAGE KEEPERS.

ALBANY, N. Y., May 19.—Governor Hughes has signed the Weimert bill, amending the lien law in a manner satisfactory to the owners and keepers of motor vehicle garages. It provides that a person keeping a garage or place for the storage, maintenance, keeping, or repair of motor vehicles, as defined by the Motor Vehicle law, and who in connection therewith stores, maintains, keeps, or repairs motor vehicles, or furnishes gasoline or other supplies therefor, with the consent of the owner, has a lien upon such motor vehicle for sums due, and may detain it when lawfully in his possession until such sum is paid.

### ENTRIES FOR JAMAICA CLOSE ON JUNE 1.

From entries already received and the large number of applications for entry blanks being made, indications point to a big field of contenders in the straightaway trials, to be run on Hill-side avenue, Jamaica, Saturday, June 5, under the joint auspices of the Subway Celebration Committee and the Long Island Automobile Club. There will be nine events at each of the following distances: Kilometer, mile, and two miles. Entries will close with Fred J. Wagner, assistant secretary, 29 West Forty-second street, New York, June 1.

### STEARNS TO MAKE A TOWN CAR.

CLEVELAND, May 18.—Within the next six weeks, or two months at the outside, the F. B. Stearns Company will place a new model on the market, to be known as a "town car." The new car will be rated at about 30-horsepower (figured on the Stearns rating of sixty), and will be equipped with shaft drive, being the first machine so constructed to be built by the Stearns Company. It will have a three-speed selective transmission and will doubtless be a candidate for honors in the apparently limitless taxicab field once it reaches the market.

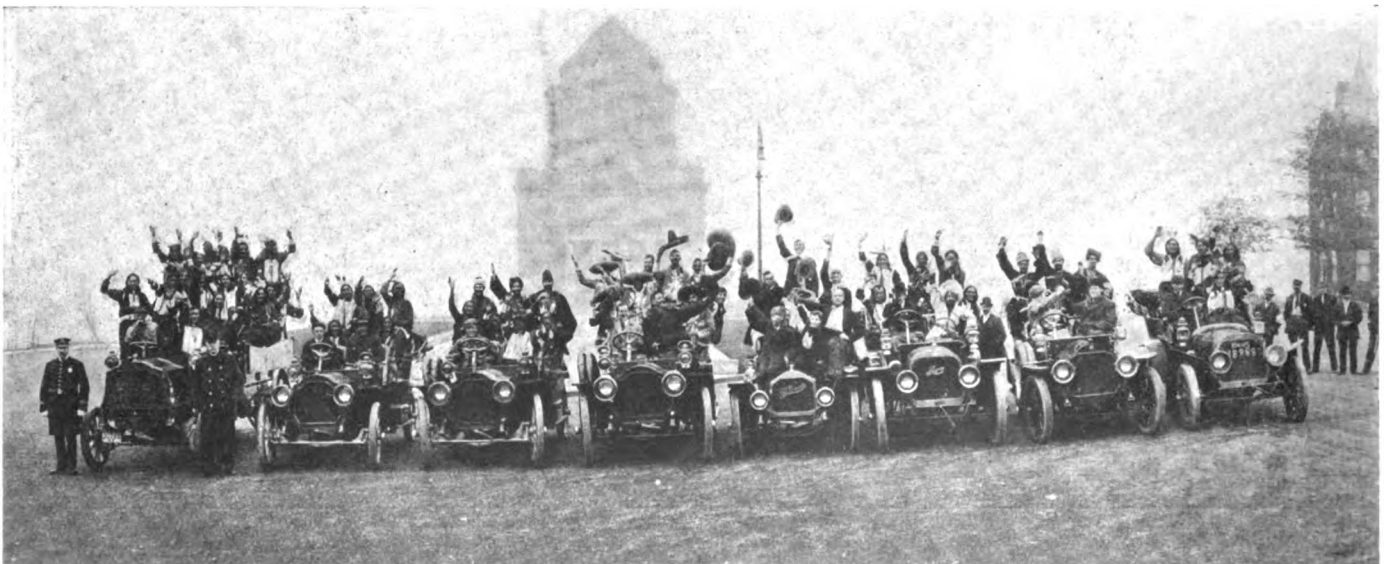

Members of Buffalo Bill's Wild West Show Enjoying an Automobile Ride in New York—In Front of Grant's Tomb.

# AUTOMOBILE CLUTCHES AND THEIR DESIGN\*

BY HENRY SOUTHER, MEMBER A. S. M. E. AND S. A. E.

IN *La France Automobile* I find reference to an unusual arrangement of springs under the leather of a cone clutch. Not that the use of springs for this purpose is anything out of the ordinary, but their location and arrangement are quite unique. These are shown plainly by Fig. 20. It is apparent that the metal of the cone is entirely cut away for a short section, admitting a flat spring not more than an inch wide. The unusual feature is the use of a pair of spiral springs supporting the two ends of the more or less flexible flat spring.



Fig. 20—Spring arrangement of cone clutch.

In some instances rubber buffers have been used under the leather in place of springs. The other frictional surface bearing against the leather is, as a rule, a cast iron flywheel.

It is obvious that the construction surrounding the clutch must be such that by no means can an unusual supply of lubricant find its way to the frictional surfaces of the clutch. The flywheel prevents any oil from the engine working its way back, being provided with oil trap grooves for that purpose, if necessary. From the other direction, the gear box, for example, oil ordinarily does not get as far as the clutch. There is usually a considerable space between the clutch and gear box. In general, it may be stated that the cone clutch is as free from variations due to lubricants as any other. The leather surfaces gradually become dry and hard, requiring the application of castor or neats-foot oil preferably, but not very often.

With proper usage, cone clutches with leather faces seem to last indefinitely. I have accurate knowledge of cars that have surely been driven 20,000 or 30,000 miles without replacement of leather on the cone face. My own experience is confirmatory of this. I have driven several cars with cone clutches and have yet to experience any trouble from the wearing of the leather face. I recently saw a clutch that had been used for about 2,500 miles by me that gave no evidence of wear, neither had it received any attention on my part, except to dose it a few times with neatsfoot oil.

There is one defect in the operation of the cone clutch that has caused considerable trouble. The clutch necessarily requires

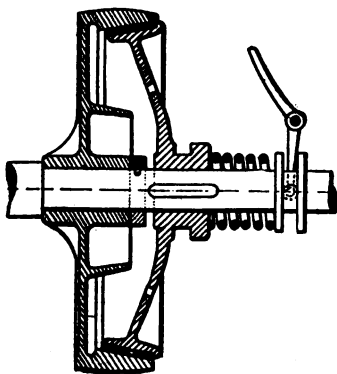

Fig. 21—Standard type cone clutch.

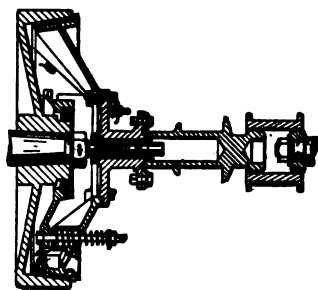

Fig. 22—Variation of the conical type.

some end or axial motion and a slip-joint that will permit it. An ordinary square slip-shaft has been commonly used. Instances have been found where these square slip-shafts have jammed under load and seized, so as to refuse to permit of the disengage-

ment of the clutch at critical moments. This is a very serious objection, and one that has not been altogether satisfactorily overcome. Improved materials, increased dimensions and better facilities for lubrication have cured much of the trouble. Generous feathers and splines have been resorted to, which present working surfaces that are normal to each other and which avoid any cam-like or wedging action which may exist with a square shaft bearing in a reasonably easy fitting square hole. Here, again, the perfect freedom introduced by double universal joints plays an important part, the square shaft being very much less apt to bind when perfectly free to center itself.

There has been a considerable variety of opinion as to the proper cone angle. Various authorities have placed it all the way

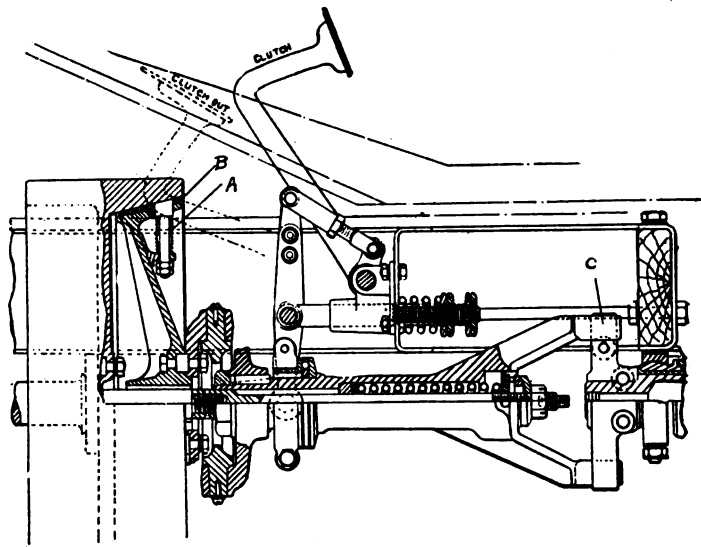

Fig. 23—Method of mounting and control of cone clutch on an auto.

from 7 degrees to 20 degrees. The French have settled down on an 8 degree to 9 degree angle as being about right for a leather-faced cone. Several important American makers are using 12 to 13 degrees, several 10 degrees, and others 8 degrees.

The following table gives the dimensions for cone clutches used on three different models which are probably as successful as any:

Area of flywheel.....	113.1 sq. in.	78.7 sq. in.	73.59 sq. in.
Angle (one side).....	8 deg.	8 deg.	8 deg.
Radius (maximum).....	8 1-2 in.	8 1-8 in.	7 5-8 in.
Spring pressure.....	375 lb.	320 lb.	250 lb.

Horsepower by A. L. A. M.

formula.....	48	42	40
--------------	----	----	----

The metal-to-metal cone clutch is a good one. It may be made smaller in diameter and with a sharper angle, say, 7 degrees, without seizing. It may be used in connection with copious lubrication. This form has been and is used only to a small extent. The dividing line between slipping and seizing is narrow. Another form of cone clutch has an aluminum male member of about 12 degrees angle bearing against cast iron and with cork inserts in the face of the male member. This clutch is not easily affected by a lubricant and, in fact, may be run with copious lubrication. This type has not been widely enough used yet to give sufficient knowledge as to the possibility of general application under many varying conditions.

Up to this time I have referred entirely to what may be called a direct-acting cone, one where the male part of the cone moves axially towards the engine. This is well illustrated by Fig. 21, which is about the simplest form of leather-faced cone clutch. Modifications of this are many, Fig. 22 showing a clutch of the same principle, but in place of having one strong actuating

\*Paper read before the American Society of Mechanical Engineers at New York, May 12. Discussion to be continued at Detroit, June 25-28, in conjunction with the Society of Automobile Engineers. Continued from page 672, "The Automobile," May 14.



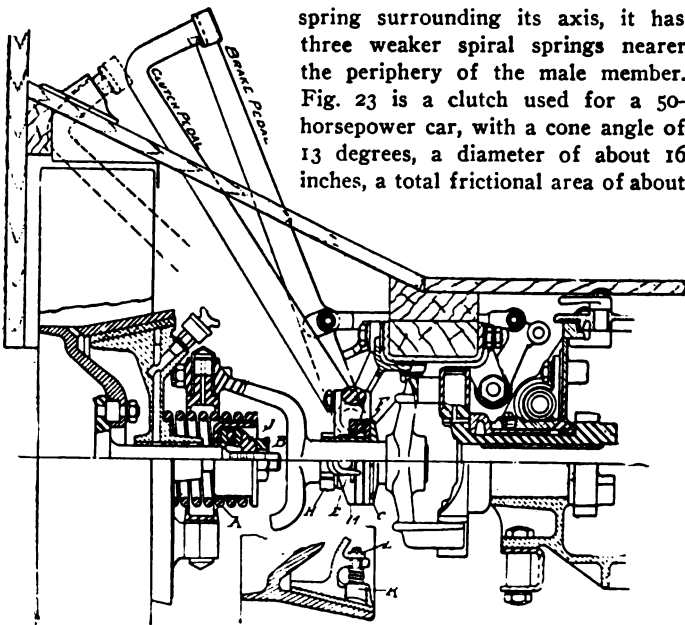

Fig. 24—Small dimensions of clutch on a 30-horsepower car.

spring surrounding its axis, it has three weaker spiral springs nearer the periphery of the male member. Fig. 23 is a clutch used for a 50-horsepower car, with a cone angle of 13 degrees, a diameter of about 16 inches, a total frictional area of about 128 square inches, and axial pressure of 375 pounds resulting from spring. This cut clearly shows a small spiral plunger spring, *A*, underneath the leather face, *B*, to make it pick up its load more quietly and smoothly. This cut also shows a form of slip-joint back of the clutch, *C*, which, although it does fairly good work, is not on the whole as satisfactory as the double-toggle universal joint. It will be noticed that the arms of this joint have been spread as widely as possible, but, at the best, the pressure and binding action is considerable.

**Striking Extremes in Cone Clutch Dimensions.**

In direct contrast to this clutch is the one shown in Fig. 24, where the diameter of the cone is very much less, not to exceed 10 inches. This is a clutch used in connection with a car developing 30 horsepower, A. L. A. M. rating, and one that has at times developed much higher horsepower on the block—as high as 36 horsepower. The clutch angle is 13 degrees and the frictional area the first two years this car was built was 86 square

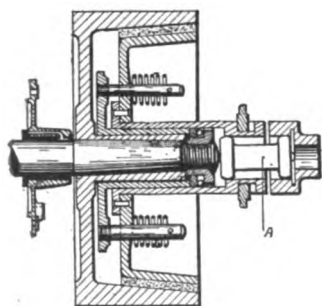

Fig. 25—Early example of conical type of clutch.

inches, but this has recently been raised to 96 square inches, the spring pressure remaining at 400 pounds. It will be noted at the bottom of this cut that there is a sketch showing the spiral spring plungers underneath the leather. Fig. 25 shows an early form of cone clutch used about 1902 or 1903 for a car of about 20 horsepower. This has multi-springs for creating the proper frictional contact and a peculiar form of spring application, simple in the extreme. One of the early forms of toggle joint is also shown at *A*. This gave in its day what was considered very good service.

**Some Modifications of Cone Clutches.**

In the *Commercial Motor* for October 31, 1907, p. 218, is shown what may be called a multi-cone clutch. This is seen in Fig. 26. The explanation, to be as simple as possible, is that when the clutch engages, the smallest cone seizes first, commences to revolve and subjects the spiral spring between the next two clutches to torsional movement, which draws them together and brings the two outer cones into action; the idea being that the small clutch shall slip, tend to accelerate the car, that the medium

clutch shall behave in a similar manner and that when the large clutch comes into play the three combined pick up the load and move the car. As far as I know, this has not been tried out sufficiently to say whether or not it is a practical success, but it is interesting in showing the amount of thought that has been given to cone clutches.

I have said that theory did not enter into the clutch very much, but below is Fig. 27, which shows the peculiarity of a simple clutch embodying the tractrix curve. This curve is adopted because it is of such a form that by the figured relation of pressures and peripheral speed, wear ought to take place uniformly at all points regardless of the distance of the point from the center. The claim is made for it that the clearance required to complete the engagement is very small; that there is no wedging action between the two members of the clutch and that there is no chance for it to bind. Also that it is simple and particularly adaptable to metal-to-metal clutches.

**Numerous Designs Show Study Devoted to Subject.**

It is in effect a flat disc clutch which will not wear faster near its outside edge than near its inside edge, but beyond that I see no gain. It would certainly require very heavy axial spring pressure, just as a flat disc would. The matter of wear is of little moment, either with flat discs or cones. The so-called inverted cone is well illustrated in Fig. 28. The reversed cone is contained in an extension *A*, built onto the flywheel *B*.

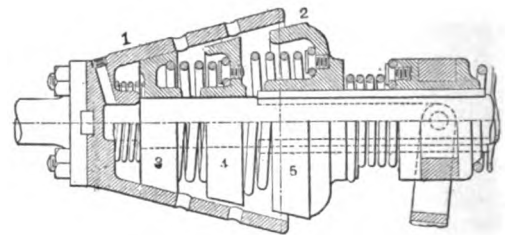

Fig. 26—A variation employing multiple cones.

When the cone is disengaged it moves toward the engine, exactly reversing the action of the foregoing type. This clutch has its adherents, and it is a good one, differing very slightly, if properly assembled, in its efficiency from the direct-acting cone. It may be kept free from dirt and oil much more perfectly than in the other form.

A simple formula for calculating the ordinary cone clutch is the following, by Chas. H. Schabinger, taken from *The Horseless Age* of October 2, 1907:

$$h.p. = \frac{P f r R}{63,000 \sin O}$$

*P* = Assumed pressure of engaging spring in pounds;  
*f* = Coefficient of friction, which in ordinary practice is about 0.25;

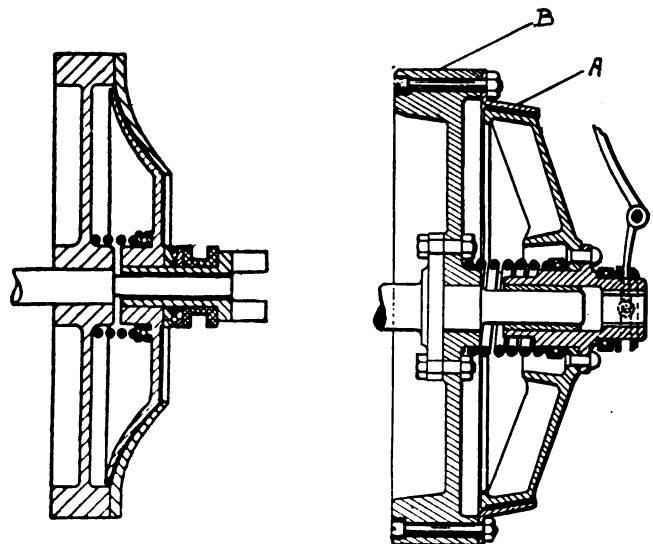

Fig. 27—Type embodying the tractrix curve.

Fig. 28—Inverted type of cone clutch.

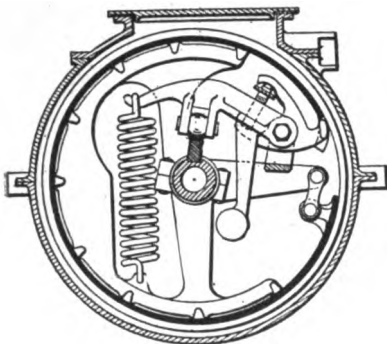

Fig. 29—Form of expanding band clutch.

used as in the preceding formula. It will be noted that the coefficient of friction used is 0.25. This is probably near enough for a properly lubricated leather-iron clutch.

The next type of clutch may be classified as internal expanding band or ring. This has had many exponents in the automobile art, but is open to centrifugal effects to such an extent that it requires considerable ingenuity to overcome troubles arising therefrom. At high engine speeds the operating levers have in many cases been so arranged as to lower the normal pressure between the frictional surfaces, resulting in a slippage and arbitrarily fixing a maximum limit of speed for the car on the high gear and of horsepower possible to develop in low gear. Fig 29 shows a clutch operating on the same principle, driving a 16-horsepower car, the spring pull being 50 pounds, the diameter of the clutch about 9.50 inches, and the width of the band 2 inches.

This clutch was a particularly soft operating one, but did release at high engine speeds. It operated best with a certain definite quality and quantity of lubricant, which, if varied to any great extent, caused a slipping clutch or a sharply biting clutch. The tendency of the clutch is to unwrap and expand against the enclosing cylinder as soon as any friction is applied to it.

$r$  = means radius of the cone in inches;

$R$  = revolutions of the motor per minute.

$\sin O$  = Sine of the angle of the clutch.

To obtain the size of spring when the horsepower is known, the following formula may be used with good results:

$$P = \frac{h.p. 63,000 \sin O}{f r R}$$

the same symbols being used as in the preceding formula. It will be noted that the coefficient of friction used is 0.25. This is probably near enough for a properly lubricated leather-iron clutch.

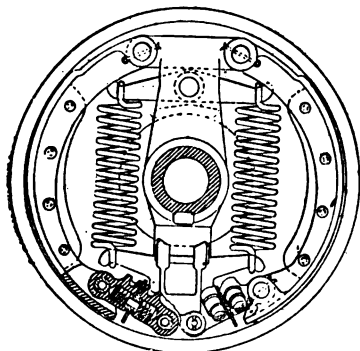

Fig. 30. Modifications of Band Types of Clutches.

The successor of this clutch is shown in Fig. 30, so designed as to overcome the centrifugal releasing effect of levers in the clutch shown in Fig. 29. The total area of the clutch is 36 square inches and the two springs are of 125 pounds tension each. This clutch was a success, but was finally given up in favor of a simple cone.

**Contracting Band Types of Clutches.**

The exponents of the contracting band type of clutch are few and far between, unless the contracting spiral be so classed, and perhaps it ought to be. Figs. 32 and 33 show a contracting band characteristic of one of the prominent French cars (Mors). A leather-lined flexible steel band (8) contracts against a steel cylindrical band (2) bolted onto the flywheel (1). Clutches of

this character are seldom found in the automobile industry, except in two-speed cars, where a planetary gear-set is used.

About 1897 a single-cylinder 10-horsepower car was equipped with such a clutch as shown in Fig. 33, a leather-lined band, very flexible in character, wrapping around the hub of a flywheel and tightened with a spring pressure of about 50 pounds against a wedge. In this clutch a weight was furnished which would throw out at high speeds and further tend to tighten the band about the hub of the flywheel. The fact that this clutch has not had any successors is an indication that it could not compete with other forms; nevertheless, it was a successful clutch, especially for its time.

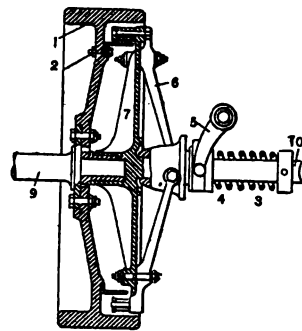

Fig. 32. Sectional and Plan Views, Mors Contracting Band Type.

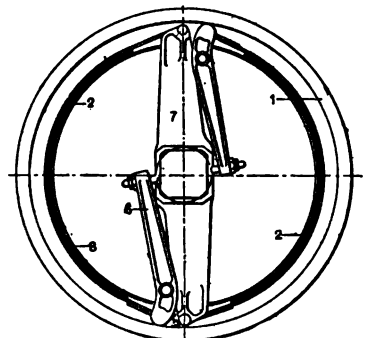

Fig. 33.

Fig. 31 shows a form of clutch that has had prominent adherents. It is the wrapping spiral spring, of either hard or soft metal. The cut indicates the spring in cross section, marked "6," wrapping on the drum 4. Probably the greatest enemy to this clutch has been the adjustment of the clutching force. With too little lubrication they will not pick up their load rapidly enough. The margin is narrow and hard to control. With a viscous lubricant there is enough drag to make the gears clash badly. The disengagement is not very complete at the best.

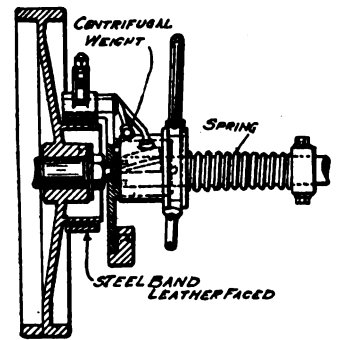

Fig. 34—An example of a wrapping band type.

(To be concluded next week.)

**NEW METAL VALUABLE FOR AERONAUTS.**

According to *Aeronautics*, McAdamite is the title of a new alloy that should prove of wide application, and be particularly valuable to the flying machine industry. Most of the best alloys heretofore produced have about 16,000 pounds compression strength, while McAdamite has 126,000 pounds per square inch. The new metal also has a higher elastic limit than most others, or 84,000 pounds before the yield point is reached. Where the very best of the bronzes could barely claim 38,000 pounds per square inch torsional strength, this alloy has 60,000 pounds, or nearly as much as some steel. In cast metals it is well known that the tensile strength is low, but even here this new metal is very strong, as it shows nearly 45,000 pounds per square inch. The specific gravity of cast McAdamite is 3.20, as against 2.56 for aluminum and 2.98 for partinium. There is a shrinkage in casting it of 12 to 14 per cent. Its melting point is 977 degrees Fahrenheit as against 1,830 degrees Fahrenheit for brass; but, roughly speaking, it has nearly three times the strength in any direction, and three times the volume or one-third the weight of brass. Various degrees of strength and hardness are obtained by the mode of casting. So homogeneous is this metal and so free from gas that intricate and delicate castings can be made.

### FRENCHMEN ADOPT QUICK DETACHABLE IDEA.

PARIS, May 13.—It is a rather curious fact that America and France should have worked on entirely opposite lines in the development of labor-saving devices for changing tires. In the United States quick-change tires, in which the outer flange only is removed, are so common as to be found on practically nine-tenths of the current models. Dismountable rims, on the other hand, have found little favor except for racing purposes, more

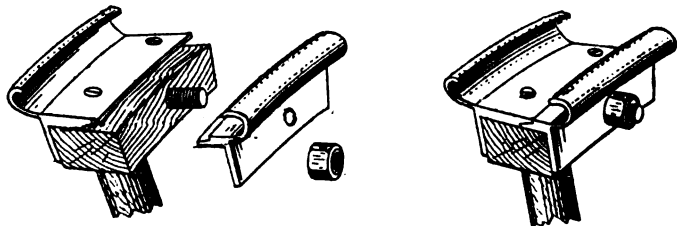

Sectional Views Showing New French Detachable Rim.

than one firm having put a rim of this type on the market having been obliged to withdraw it for want of support. In France the dismountable rim has long been recognized as a necessity for touring, several firms fitting them without extra charge as a standard equipment, and supplying special brackets for carrying the inflated tires. The quick-change rim, so familiar to Americans, has hardly existed.

One of the first of this latter type has just been put on the market, and, because of its distinctive features, is worthy of a description. The steel rim encircling the felloe is in two parts, one, consisting of the inner flange and encircling band, being permanently attached to the wheel. The outer detachable flange portion is secured on six bolts passing through the face of the wooden felloe and held by six nuts. For further security, the detachable rim is made with a tongue fitting under the lip of the permanent rim. Safety lugs and valve are of the ordinary type. Compared with the usual type of detachable rim there are six points of attachment instead of one, but the few extra seconds spent in attaching are repaid by the assurance that it is impossible for the detachable section to detach itself when not desired.

### A Mirror to See the Road Ahead.

An improvement on the usual type of mirror employed to show whether the road ahead of an obstructing vehicle is free or not has been put on the market by a French inventor. Owing to the fact that he is seated low, the driver of an automobile is more handicapped in this respect than the person in charge of a horse vehicle. The improvement, as shown in the sketch

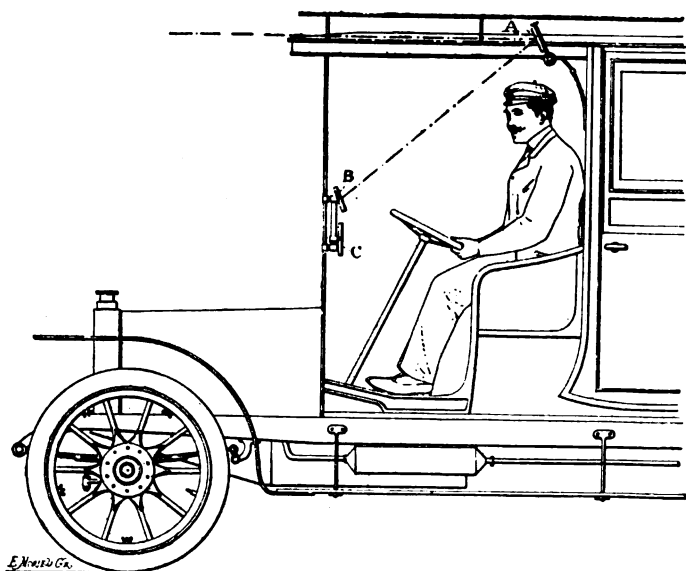

Diagram Illustrating Location Road Reflecting Mirror.

reproduced herewith from *L'Automobile*, consists in placing a mirror at as high a point as possible on the left-hand side of the body of the car. The mirror *A* has thus a much longer range of vision than is possible to the man at the wheel of the car. The mirror *B* attached to an upright from the outer edge of the dash, is pivoted in such a way that it can reflect all that is shown by the observation mirror *B*. The practical result of the arrangement is that the driver's range of vision is equal to what he would have if seated with his head on a level with the roof of the car. The third mirror *C* is the one usually employed to show whether any vehicle in the rear is attempting to overtake the car.

### LATEST NEWS OF THE GRAND PRIX.

PARIS, May 15.—Gasoline and tire stations at the grandstands on the Dieppe course have been drawn for by lot, in order that the parties interested might, if desired, rent grandstand seats opposite the spot on which their own cars will draw up. The Thomas car, which was represented at the meeting by W. S. Hogan, the A. C. A. delegate in Paris, drew seventh position, immediately after Mercedes and Austin, and just before Panhard and Weigel. The first number drawn gave the firm represented the right to the box nearest to the starting and finishing line, the others following after in the order of drawing.

The first position fell to Dietrich, the others following in this order: Germain, Bayard-Clement, Mercedes, Austin, Thomas, Panhard, Weigel, Samson tires, Continental tires, Nanterre oils, Bosch magnetos, Dunlop tires, Michelin tires, Renault, Motobloc, Opel, Brasier, Fiat, Porthos, Itala, Benz. The space given to each firm, whatever the number of cars entered, measures 15 by 16 feet between the front of the grandstand and the road. The boxes themselves are slightly sunk down in the ground, and will hardly be visible from the stands, but the cars themselves, drawn up opposite them, will be in full view. As the men at the stations are only allowed to hand goods over to the drivers, and must not give any help whatever, nothing would have been gained by putting their quarters on the level of the road; the boardings would, indeed, have tended to hide the cars and their teams from the view of the spectators.

Immediately the stations had been selected, the firms concerned secured their own positions for the two days of the races, naturally renting those seats which would give them a full view of their own cars. It is declared at the club that the demand for seats is stronger than usual at this early date.

### Entries Finally Close Monday, June 1.

Final closing of entries for both the Grand Prix and the Voiturette races will take place on June 1, by which date it is expected that the former list will have been lengthened by the engagement of three Mors cars already on the road, and which will be entered if they give satisfactory results on the road tests. The drawing of positions for the start of the races will take place at the clubhouse on June 5.

The full team of Panhard racers has now been put on the road, making the fourth set of Grand Prix cars to leave the factories. The others are Bayard-Clement, Motobloc and Benz. Though the external features of the new Panhards cannot be hidden from the public, the factory officials are not at all talkative about their models or inclined to give any information about the tests made. Last year's dashboard radiator, on the lines of the Renault, which was a distinctive feature of the Panhard, has not been repeated for 1908, the new cars having a strongly pronounced Panhard appearance with the familiar type of radiator just behind the front axle. Final drive is by double side-chains, as in the touring cars, the employment of shaft drive, which has been a feature of Panhard racers since 1904, not being continued this year. Regarding the engine, not much more can be learned than that it is a four-cylinder of the maximum bore and 6.6 inches stroke, the cylinders being of steel and copper jacketed as last year.

## INTERESTING GAS ENGINE CYCLE DEVELOPMENT

By ERNEST COLER, MEMBER SOCIETY OF AUTOMOBILE ENGINEERS.

THE two- and four-cycle engines now in use are outgrowths of the Beau de Rochas cycle, supposed to conform to his four axioms covering the ideal conditions of gas engine operation. These axioms are as follows:

1. Highest possible pressure at the beginning of the stroke.
2. Maximum speed of expansion.
3. Expansion to the lowest possible pressure.
4. Maximum cylinder volume with minimum wall space.

The Beau de Rochas cycle falls short of these conditions, because—

1. The highest pressure is not reached with a given compression on account of imperfect scavenging.
2. The speed of expansion is limited to that of the piston, which has a limit for mechanical reasons. In this respect, the "free-flying piston" engine is superior.
3. Expansion is not carried very far. Pressures as high as 60 pounds per square inch are rejected to the exhaust.
4. Maximum volume with minimum surface is counteracted by excessive wall cooling necessitated by lubrication, preignition and charge-reduction conditions.

With a view to overcoming these disadvantages, Robert Miller has developed an internal combustion motor having a modified cycle, and which combines the features of lightness with frequency of impulse and a minimum number of parts. In this new motor, the "Miller cycle" modifies the foregoing conditions in the following manner:

The pressure at the beginning of the stroke will be higher, as the cylinders and clearance spaces are thoroughly scavenged by an excess of cold pure air.

The speed of expansion is increased by allowing the burning charge to expand simultaneously in a supplemental expansion cylinder during the expansion stroke only. Since the combined volume of the combustion and the expansion cylinders is thrice that of the combustion cylinder, the speed of expansion must be three times as fast as that in an ordinary cylinder with the same piston speed and stroke.

To illustrate this, we will assume a piston speed of 900 feet per minute, and a stroke of 12 inches. The ordinary cylinder will expand its charge from 300 pounds to 45 pounds per square inch in 1-900 of a minute. The "Miller cycle" expands this same charge between the same limits, in 1-3 of 1-900 = 1-2700 of one minute.

The expansion must be carried to a lower limit, in view of the above statement, because this same expansion cylinder will bring the terminal pressure down to about 10 pounds per square inch, the terminal volume being three times the initial volume of the charges above compression.

This method of increased expansion differs widely from the two commonly used. The true compound gas engine (two-stroke expansion) fails because of the low specific heat of the working fluid, the transference of highly heated gas through small ports and valves, which must be kept cool to insure durability, and the enormous amount of cooling surface in-

involved in a high and low-pressure cylinder. The other method, using a small charge (either cut short on the suction stroke or expelling some on the compression stroke), involves a long stroke, and what is gained by increased expansion is lost by increased time of contact with cold cylinder walls. Wall cooling is effected in the "Miller cycle" by the scavenging action of the cold air acting upon the inside of the cylinder. The cycle itself gives a cool cylinder wall, and the exhaust is used as an ejector to draw cold air over the outside of the walls, where necessary, thus rendering the engine independent of fans, pumps, blowers or radiators. The fuel injection also abstracts heat from the charge, because liquids, to pass into vapor, must receive heat.

The engine will be light per unit of power, because more heat will be converted into work instead of being wasted through the cylinder walls and in the exhaust; also the charge weight and M. E. P. must be higher, because the charge is cold, at atmospheric pressure, and its fuel component is added during the compression stroke. Its reliability will be insured because every charge is uncontaminated with burnt residue, and it should be superior to the four-cycle, for the same reason that the four-cycle is superior to the two-cycle—differences in scavenging; and, in addition, the fuel being injected positively during the compression stroke, there are no carbureter troubles.

Referring to the accompanying drawings, we shall go through a complete cycle in one cylinder, the drawing showing a double-acting engine. Assume that in the clearance space of the upper cylinder an explosion is about to take place. At that moment the valve *b* being open, establishes communication between the chamber *a*, and the expansion cylinder *c*, the valve *d* being closed. The result is that the force of this explosion will be expanded in the cylinders *a*, and *c*, so that the expansion will be very rapid, and as the piston reaches the end of its stroke the volume of the combined cylinders *a*, and *c*, will be much greater than of *a*, alone. The expansion must then have been carried to somewhere about 10 pounds terminal pressure, with the result that very little heat has gone through the cylinder wall. While the differential piston was moving in this direction, having on one side the explosive impulse, on the other side it

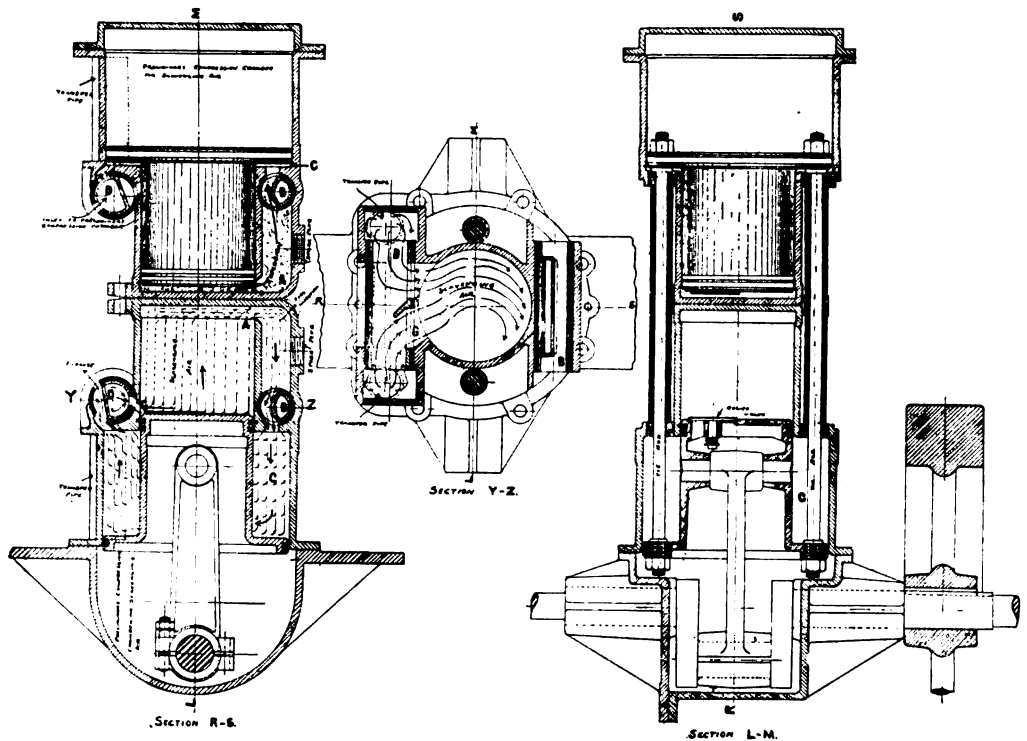

Sectional Elevation, Cross Section and Plan Sectional Views of the Miller Engine.



was compressing the pure air that is contained between it and the cylinder head, after the manner of the Diesel cycle.

As the differential piston nears the end of its stroke, the valve *d*, will open so that the remaining pressure in the combined cylinder volumes *a*, and *c*, will escape through one port in this valve. As this pressure dies away, the compressed air from the preliminary compression chamber will go through the connecting pipe, through the valve *d* and through the ports *g*. Coming through the ports *g*, this air will traverse the body of the cylinder *a* around through the clearance, through the valve *b*, around through the chamber *c*, and out through the exhaust port of valve *d*. Being in volume about three times as large as that of the cylinder *a*, this pure air will thoroughly scavenge the cylinder, clearance and all, at the same time exercising a cooling effect. That this scavenging will be superior to that of the ordinary cycles will appear when it is considered that in the ordinary two-cycle the scavenging is generally considered to begin at the outer dead center. With this cycle, however, owing to the fact that the gases, at release, are already expanded to a low pressure, scavenging will commence much earlier, and in that most effective part of the stroke, the slow period around the dead center. The time element is an important point in two-cycle functioning.

The piston is now ready to start on its return stroke. The valve *b*, closes, and the valve *d*, remains open. The contracted portion of the differential piston compresses pure air in the chamber *a*, while the differential portion of the piston sweeps out the combined burnt gas and air through an exhaust port in the valve *d*. At a predetermined period of the stroke the fuel pump injects the charge into the chamber *a*, where it is thoroughly mixed by the whirl of the compressed air from the piston. Just before the stroke occurs, the valve *d*, is closed, and the valve *b*, gradually opens. During this time the trapped gases in the chamber *c*, are gradually brought to approximately the same pressure as exists in *a*. Ignition then occurs, and the cycle

is repeated in exactly the order of operations just explained.

It must be remembered that on the inward-stroke, while the differential piston is on its smallest portion compressing the new charge, and on its larger portion expelling the burnt gases from the chamber *c*, on the other side it is drawing in a new charge of air through a check-valve, or through a modification in the valve *d*. This engine renders self-starting very easy. It is hardly possible, with the clutch out, that it would stop on dead center, because it would be against the full compression in either combustion chamber. It would, therefore, stop somewhere near mid-stroke. If the fuel pump inject fuel into the chamber *a*, and also into the chamber *c*, ignition in *a*, would travel through to chamber *c*, and a powerful impulse be given to the crankshaft, somewhat in the manner of the compression explosion obtained with the Clerk-Lanchester self-starter, as used in large English gas engines. Reversing with this engine, while probably not desirable for small motor cars, may yet be used for railway and trolley car work.

Assume, in the double-acting type, that an explosion occurs in the top cylinder and, therefore, a new charge is being compressed in the lower cylinder. If a reversing eccentric be fitted and the engine be thrown into a reverse position, in the top cylinder, which is going through an explosion impulse, the exhaust valve *d*, will open, relieving the impulse, and in the lower cylinder the differential portion of the piston, instead of expelling the burnt gases, the valve *d*, will close, and the engine would gradually slow up on an air cushion, the gases being trapped in the cylinder. As the engine slows up, the igniter being tripped prematurely, the engine would reverse both from the premature explosion and the energy stored up in the compressed gases in the cylinder *c*. Rotary valves are shown, but, of course, poppet valves could also be fitted. The rotary valves have the advantage of simplicity and long life, if properly cooled, and are used on the largest air compressors, while none of the other features of the motor represent departures out of the ordinary.

### MECHANICAL BRANCH MEETS IN CLEVELAND.

In accordance with the policy suggested at the meeting of the mechanical branch of the Association of Licensed Automobile Manufacturers in Chicago last December, that the branch meetings be held at different points throughout the country, in order to give the engineers an opportunity to inspect and study the different factory methods of its members, the next meeting of the mechanical branch will be held at the Hollenden Hotel in Cleveland Friday, May 22.

The morning session will be devoted to taking up the subjects of proposed standard brake and clutch levers, which have been given a certain amount of attention by the engineers, and especially the Test Committee, for the past three or four months. A full report of data gathered by the Test Committee relative to the dynamometer of the Automobile Club of America will be given and discussed. The report of the dynamometer tests, held earlier in the month, is expected to contain some interesting matter. Papers on the two-cycle motor will be read by E. W. Roberts, and A. W. Thompson, of the Electric Welding Products Company, will give an illustrated lecture on the advantages of combination valves, nickel steel heads and carbon steel ends.

In the afternoon, and possibly the following day, the local factories will be visited by the engineers in a body, and factory and shop methods will be closely studied by the visitors. Thomas Henderson, vice-president of the Winton Company, located in Cleveland, and a member of the executive committee of the Licensed Association, is arranging the details of the inspection trips, and he hopes to have a very interesting and educational program arranged. This interchange of visits to the different plants of the members of the Licensed Association is one of the chief features of the policy recently adopted of holding the meetings of the Branch in different cities that members may become conversant with the various shop systems and methods.

### INDISPENSABLE BOOKS FOR TOURING.

The publishers and compilers of THE AUTOMOBILE "Blue Book" have one object only, and that is, as practical autoists, acquainted by road experience with the actual necessities of other drivers, to meet the everyday matter-of-fact requirements of the man at the wheel, and to give the best and most accurate routes, details, directions, and maps which can be made or gathered from reliable sources. To obtain this, they have on the road their own machine, with competent investigators and compilers, and also have the cooperation of secretaries of automobile clubs and hotel men and every garage keeper who can be impressed into the service. Even then, with all their accumulated knowledge and zeal (indeed, by reason of it), there comes with every year the need for a revision and extension of every section.

It is in the order of requirements that New England should receive the publishers' first consideration, for into it, and through it, flows the greatest percentage of the summer automobile traffic of the continent. With this, the latest and best fund of material facts, at his finger tips, the traveler will be enabled to lay out a route to suit his time and desire. It is all there, either in broad, simple, comprehensive skeleton maps, or in detailed diagrams, showing where to start, where to turn, how far has been covered in a given time, and where to stop, as well as that equally important factor, where supplies can be got, or repairs made to his machine. And all this indexed, cross-indexed, and dovetailed together into such a simple whole that a man may travel for weeks through all the States of New England, in a thousand different directions, and find all the material information within the limits covered betwixt a pair of covers of a light, thin, flexible book, easily and cozily snuggled away in a driving-coat pocket or a get-at-able receptacle. It is the compactness and accessibility of the great amount of information furnished that appeals to the autoist as much as its intrinsic value.

## LETTERS INTERESTING AND INSTRUCTIVE

### CAUSE OF EXHAUST VALVE STEM BURNING.

Editor THE AUTOMOBILE:

[1,366.]—I have a single-cylinder motor which is air-cooled around the body of the cylinder and has a water-cooling chamber on the cylinder head, and have had trouble for the last three months with the exhaust valve stem becoming burned where it joins the head. I had no trouble with the original valve, but had to replace it as the slot had cut through the end. I have since made three new valves—the first from a forging and the second two from cold rolled steel. The first broke off at the head, after running about three weeks, and seemed badly burnt, and it is now necessary to replace the third one, as the stem is burnt to about half the size. I have carefully ground each valve with powdered emery and they run nicely at first. Do you think there is something wrong in the cooling, or is the trouble caused by the valve not opening enough? Kindly advise me through the columns of "The Automobile."  
W. S. CHISHOLM.  
Benicia, Cal.

We think it is probable the trouble may be caused by the fact that the hole in the casting through which the valve stem works may have become worn sufficiently to permit the exhaust gases to escape around the stem to a certain extent, which would readily account for the burning at the point in question. Watching the motor closely while working should reveal whether this is the case or not. We do not believe it is due to any defect in the cooling, though if the water-jacket mentioned includes the exhaust valve pocket, an examination may show that this portion of the cooling system is not working as efficiently as it did originally. In case the cause is found to be due to the worn valve stem hole, the best remedy is to drill the latter out and fit a bushing. Of course, a larger valve stem might be used, but as this would be apt to increase the weight of the valve it would not be an advantage. The cam and roller of the exhaust valve-operating mechanism may also show considerable wear, thus reducing the amount of opening, which would also cause overheating.

### ABOUT THE ORDER OF MOTOR FIRING.

Editor THE AUTOMOBILE:

[1,367.]—Referring to inquiry No. 1,344, I do not see how Mr. Bryant can fire his motor in the order 4, 2, 3, 1, if the cranks are set 180 degrees apart, as in most four-cylinder motors. When No. 4 is going down on the firing stroke, No. 2 is going up on the compression stroke; No. 3 is going up on the compression or the exhaust stroke, and No. 1 is going down on the suction stroke. No. 3 cannot be on the compression stroke with No. 2, so it must be on the exhaust stroke, so that the cycle is disarranged. I think his motor fires 4, 2, 1, 3 or 4, 3, 1, 2.  
Pittsfield, Mass.

W. J. EAGE.

A little study of the order of firing the average four-cylinder motor in which the cranks are arranged in pairs in two planes, 180 degrees apart, will show the order mentioned by the inquirer in question (1,344), to be erroneous. This, however, had no particular bearing on his inquiry, which concerned the manner of timing a magneto to run the motor, as it is only necessary to time one cylinder to bring the two in step, as the magneto contact maker and distributor are so designed as to fall into step with the motor, and remain synchronous with it, once they are properly adjusted. It must be apparent that where the order commences 4, 2, cylinder No. 3 cannot be the next to fire, as in order to do so it would have had to be on its suction stroke at the same time as cylinder No. 2 is compressing, which is out of the question, owing to the fact that it is then on an up-stroke. If the latter were a compression stroke, then cylinders Nos. 2 and 3 would have to fire together. The changes you suggest would remedy matters, taking cylinder No. 4 as the first to fire in each instance. It will be apparent that, as the two pairs of cylinders are in different planes, the end pair and the center pair usually running together, it is impossible for the two cylinders having pistons in the same plane to follow one another in the order of firing, for reasons that must be obvious.

### WINDLASS USED ON THE FLORIDA TRIP.

Editor THE AUTOMOBILE:

[1,368.]—Regarding the inclosed clipping from "The Automobile" of last week, describing the trip through Florida, will you not kindly publish a sketch or further directions, making plain the method of constructing and using this windlass? All autoists would appreciate this information, of such a contrivance, if it will "pull the bottom of the earth out." I cannot find any mechanical engineer who understands it from the description given. J. A. C. K.  
Newburgh, N. Y.

The clipping reads as follows: "Then came the job of getting the Peerless out of its predicament. The guide put through a plan that future tourists should remember. Our salvation was what he called a 'Spanish Windlass.' Let me tell you that it beats a block and tackle or a team of horses all hollow, and it is always available. There were no trees within reach, so 80 feet in front of the car he planted a stake, to which he fastened one end of the rope. Then half way between it and the car he planted another stake, around which he made a turn of the rope and a loop, into which he inserted a strong sapling pole he had cut. The other end of the rope was fastened to the axle of the car. Then two of us manned the sapling pole and walked around with it while two others pried up the car wheels with poles placed beneath the rear axle and hubs. We yanked the car out fairly easy. 'You can pull the bottom out of the earth with that,' said the guide. He did not seem far wrong in the light of our experience."

Editor THE AUTOMOBILE:

[1,369.]—In John C. Wetmore's article, "Skirting Florida's East Coast," published in your issue of April 23, he describes in the last half column a "Spanish Windlass." If you will refer to this, I think you will see that his description is rather vague. I would like to know just how this contrivance is set up and operated, and will be greatly obliged if you can furnish this information.  
Worcester, Mass.

HORACE H. FIELD.

As will be apparent from the accompanying sketch, a rope is made fast to the forward axle of the car and led to the nearest tree or other solid object, failing which a stake is solidly driven into the ground, and the rope attached to it.

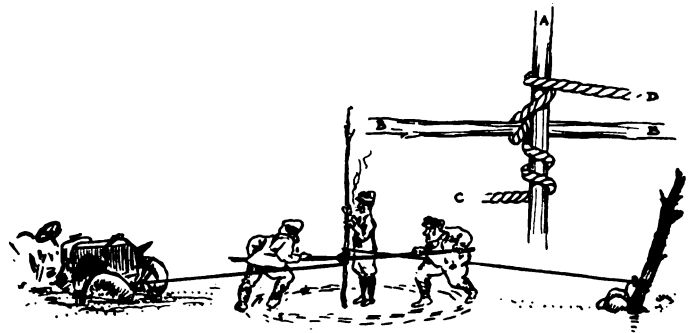

The Spanish Windlass and Its Method of Operation.

About midway between the car and this stake the rope is wound around a pole, a small tree usually forming the most available material for this purpose. A second pole, or lever, is then inserted in a loop of the rope where it is wound around the upright pole, which need not be planted firmly in the ground, but can be held by one of the party. By placing a man at each end of this long lever and walking around with it clockwise, the rope having been wound upon it in that direction, the device virtually forms a windlass and it will be apparent that the rope will wind up on the pole from both directions, and if a long pole is employed to insert through the loop of the rope a tremendous leverage can be utilized.

The arrangement in question is graphically illustrated by the accompanying sketch, which will serve to make the details much

clearer than would be possible with a ream of description. If a tree is available for the anchoring point shown at the right-hand end, so much the better. Otherwise the stake will have to be as firmly planted and braced as the car is imbedded in the mud—in fact, more so, as the amount of force necessary to start the car moving from its bed must not be such as to disturb the stake. Otherwise the stake would be pulled up instead of moving the car. The pole or sapling held by the man in the middle, who is doing the heavy looking-on, need not be extra heavy, though once the rope begins to wind on it some distance from the center, it will begin to bend considerably under the strain. If it be not stiff enough to stand it, and the car is still far from being out of its predicament, a fresh start may be made by unwinding the rope from the pole until it is back to its original three or four turns, the surplus rope being taken up either at the car axle or at the other end. It is not necessary to plant this upright pole in any way, as its holder must move backward as the winding of the rope brings the whole windlass nearer its anchor.

The details of the manner of winding the rope and inserting the third pole, which is used as the sweep of the windlass, is shown on an enlarged scale by the sketch in the upper right-hand corner of the drawing. The upright is represented by *A*, the windlass sweep by *B*, and the rope by *C* and *D*, the former end going to the car axle, and the latter to the anchor.

#### USING DOPE IN A PLANETARY GEAR SET.

Editor THE AUTOMOBILE:

[1,370.]—In "The Automobile" of April 23 you have a letter, No. 1,321, treating on the use of a mixture of sawdust and grease for the purpose of silencing gears. I would like to ask if such a combination would be good in the planetary transmission of a Model S Ford, which transmission, as everybody knows, is very noisy.

Belleville, Ill.

H. C. GASS.

The instructions of the makers of cars equipped with this type of gear-set are usually to the effect that nothing but comparatively light oil should be used in them, chiefly for the reason that the pinions are so small that the introduction of a heavy grease would tend to increase the friction of the gear to a great extent. This would seem to be the only objection, and, as your car has plenty of power to spare, it would not be detrimental to resort to this expedient to get rid of most of the noise. The planetary gear-set is something that is extremely difficult to make silent when running on the low gear, or idle, though much of the noise created by the Ford seems to be occasioned by the high speed at which the motor is run. You will find a later letter, No. 1,345, in the issue of May 7, in which the writer describes his experience with silencing compounds, and which you will doubtless find very interesting. There seems to be no reason why the same expedient could not be adopted in your case.

#### WANTED: A LIGHT 2-CYCLE AIR-COOLED MOTOR.

Editor THE AUTOMOBILE:

[1,371.]—I want to build a light car that will take hard roads and steep grades, and one that will give no trouble to those having no experience in taking care of a motor or car. I would like to employ a two-cycle, air-cooled motor, as it is light for the power, has few parts, etc., but have some friends who tried a certain make and they were not satisfied at all. I have a circular of the Speedwell motor, and letters from a Pennsylvania firm, A. H. Yocom, Reading, Pa. According to the description of their motor, I think it is what I want, but I cannot afford to make experiments and must get the right thing the first time. I am a good mechanic and am able to build anything in this line, as you will see by the car I have just completed, which I am sending you a blue-print of. If you care to publish this, with a description, I will send you a better photograph and tell you what can be made in the Far West, a long way from anywhere.

Jerome, Ariz.

ARTHUR HENDEY.

We are not acquainted with a two-cycle motor of the name you mention, nor do we know the product of the firm in question, and so are not in a position to help you out in either case. We should be pleased to receive a photograph of the car you have built, together with a description of it, for publication.

#### ONE SET OF PLUGS WITH DUAL IGNITION.

Editor THE AUTOMOBILE:

[1,372.]—Will you kindly answer, in "Letters Interesting and Instructive," this question? Would it be possible to use a single set of spark plugs in a six-cylinder engine that has an Eisemann low-tension magneto and a storage battery system of ignition? Both systems are entirely separate now, and I use two sets of plugs, which are set in a funnel-shaped brass casting, so as to have both plugs over the intake valve on each cylinder; this method of placing the plugs brings them about an inch and a quarter out of the cylinder.

Minneapolis, Minn.

C. B. RICHARDS.

This is done on the Packard car and forms a regular part of its standard equipment. You say Eisemann "low-tension" magneto, but presume you mean high-tension. The makers of the Eisemann will provide you with the necessary parts for making the change.

#### MARKETING AN AUTOMOBILE INVENTION.

Editor THE AUTOMOBILE:

[1,373.]—Being a reader of your paper, I take the liberty of writing you. Can you give me the desired information? I have invented an automobile street sweeper, and would like to submit my invention to a company, manufacturers of electric or gasoline trucks. I thought you could advise me as to the company most likely to be interested in such an invention.

Hartford, Conn.

W. H. HADLEY.

We are not in a position to give you any information concerning a manufacturer who would be apt to take an interest in your invention, but the publication of your letter in these columns may chance to bring it before someone who may be able to help you out.

#### AN EXPLANATION OF THE MAGNETO TROUBLE.

Editor THE AUTOMOBILE:

[1,374.]—I note H. J. Bryant's trouble in replacing his magneto. In your issue of the 7th. While your directions for replacing and setting same are all right, it might be of interest to have some sort of an explanation of his trouble.

Most magnetos have their armatures turn at crankshaft speed. There are, far as I am aware, only two exceptions to this rule. Incorporated with most magnetos is a secondary current distributor. This, of course, turns only at one-half of the crankshaft speed, therefore the distributor only makes one revolution to two of the armature shaft. If the armature of the magneto had received one complete turn while the magneto was off its position on the motor or the motor had received the same, everything would have been replaced apparently as it was before, but the distributor would be found to be one-half a revolution out of the way. This would not be apparent without an examination of the motor and the distributor.

The simplest remedy would be to remove the magneto and give the armature one revolution or to disconnect the two-to-one gear of the magneto distributor and give the distributor one-half of a revolution. It is immaterial which of these is done, but one may be mechanically easier than the other.

Boston, Mass.

HAROLD H. BROWN.

#### FOR TOURISTS WHO CROSS THE BORDER.

Editor THE AUTOMOBILE:

[1,375.]—Under the heading "Taking Cars Across the Border" in your issue of the 30th ult., you make mention that for a sum not exceeding \$10 we are able to furnish all that is necessary for an American touring Canada where the car crosses by way of Niagara Falls, Buffalo or Detroit. This is perfectly correct, but we would like it understood that we are able to send the requisite documents and tags through the mail to the home of the intending tourist, enabling him to cross without delay or interference at any point on the frontier.

Niagara Falls, Can.

THE C. S. WARNER COMPANY,

Roland Margetts, Mgr.

#### WHAT AN INTERESTED OBSERVER SAW.

Editor THE AUTOMOBILE:

[1,376.]—Coming downtown recently I saw the latest thing in taxicabs. It was a car of uncertain vintage and ungainly lines with an equally awkward-looking body perched on it, and—it had a taximeter, but observation failed to reveal any connection with the wheels by which it could operate when traveling.

New York City.

S. R. L.

# TEXAS FINDS AUTO AN ECONOMICAL NECESSITY

By F. S. SLY, TRAVELING CORRESPONDENT FOR THE AUTOMOBILE.

**H**OUSTON, TEX.—This city now boasts one of the most flourishing automobile clubs to be found anywhere in the Southwest. Beside the 200 or more cars here, most of which belong to members of the club, there are many non-owners who are working hard for the club's benefit and the cause of automobiling. In fact, the club has been largely instrumental in securing the recent issue of \$5,000,000 in bonds for the improvement of the roads of Harris county. H. T. P. Wilson is the presiding officer of the organization, while Sam Bering is secretary and treasurer.

A great many well-known cars are represented here, in addition to which manufacturing has been begun on a moderate scale by the Southern Motor Car Company, which builds the Dixie.

There are no less than five up-to-date garages run by the following: J. Wade Cox, representing the Ford; Empire State Motor Car Company, handling the Maxwell, American Roadster and American Mors; Houston Motor Car Company, the Pierce, Thomas and Mitchell; Mosehart & Kella Company, the Locomobile, White and Buick, and the Auto & Motor Boat Company, the Wayne.

Business has not been unusually brisk so far this year, but the prospects for a good selling season are bright.

## San Antonio One of the Best Auto Marts.

**SAN ANTONIO, TEX.**—Trade has been very quiet here this year up to the present, and the dealers are not looking forward to an over-prosperous season. The vast road improvements planned will do much to awaken interest, and there is no doubt that quite a number of cars will be sold within the next few months. A very large slice of the \$5,000,000 good roads' appropriation is to be expended in this vicinity; all roads leading out of the city are to be macadamized for a distance of 12 miles, in addition to which there is already an 18-mile macadamized loop in existence, and it is expected that a 40-mile loop of macadamized road will be completed during the coming summer. It is anticipated that a road race will be planned for this course as soon as it is completed, besides which the auto races are a very prominent feature of the fair to be held in September.

There are now 285 cars owned in the city, while quite a number of farmers in the surrounding country invested in cars last year, one firm alone having disposed of no less than 35 cars to agriculturists last summer.

The local club, of which Dr. W. B. Russ is president, H. E. Ogg, vice-president, and Dr. Fairfield, secretary and treasurer, is a progressive organization that counts about 65 owners of cars among its members.

There are quite a number of different cars represented here, but only three garages. The Automobile Station, which

maintains one of them, handles the Stevens-Duryea, Studebaker and Buick, while the Alamo Garage has the Stoddard-Dayton and the Auburn, and the Cook agency, which runs the third garage, represents the Ford and the Reo. The remainder are simply agencies, Bert Robbins having the Mitchell; Mackay has the Holsman, and the Fink agency, the Duer and the Brush run-about.

## Texas a Paradise for the Highwheeler.

**AUSTIN, TEX.**—There are many more of the high-wheel buggy type of automobiles in this part of the country than anywhere else I have been. They are to be seen running around in numbers, and their use is not entirely confined to the rural population either, although they are naturally a favorite with the farmer. Quite a number of them were sold in this vicinity last year, and they are said to give excellent satisfaction in service. The Texas farmer usually does things on a pretty good scale, and is accordingly well accustomed to taking care of machinery, so that he finds the simple power plant of the high-wheeler a practical affair and has little or no trouble with it.

There are three good sized garages here, the Austin garage, representing the Pope-Hartford, Ford, Reo and Holsman; the F. Fischer Auto Company, and the Twentieth Century Garage, which do not do any agency business. Among the agencies here are A. C. Goethe, handling the Rambler; Howard Taylor, agent for the Dorris, and Elwell Nalle, who has the Thomas. The greater part of the demand for cars here comes from the country districts, some being bought by farmers, but the majority being used by country doctors.

There are about 75 cars in use in the city itself, and there was a club at one time, but apparently it no longer exists. The country roads are poor but passable, which is not saying a great deal.

## Waco Has Some Good Stretches of Road

**WACO, TEX.**—There is one fine stretch of well-paved macadam road, 28 miles long, leading into this city, and there are also six or seven stretches of gravel road, seven or eight miles long, that are good. The rest are just about the average of the usual Texas road, which is poor. There are about 80 cars used in the city, but thus far no attempt has been made to organize a club.

The Franklin line is handled here by M. T. Bell; the Ford, by H. T. Cruger, who also maintains a garage, and the Maxwell line is represented by Percy Willis. M. Dupree has the Glide agency; S. F. Kirksey, the Thomas; and B. G. Campbell, the Buick. The Texas Auto & Transportation Company maintains the only other garage.

## Business Prospects Bright in Dallas.

**DALLAS, TEX.**—This city is really the true fountain-head of Texan automobiling, for it can boast of more than 250 cars, and it has one of the most flourishing automobile clubs to be found anywhere in the Southwest. Colonel Hunter is the president, and Eugene Corley, the secretary and treasurer. The club holds runs every now and again, and is a strong advocate of the good roads movement. That it has been instrumental in accomplishing considerable in this direction seems evident from the fact that there are fully 200 miles of good macadam roads in this county. The black roads are good going in the summer, but very bad in winter. Business prospects are excellent, one agent already having disposed of 15 more cars than at the same date last year.

There are three large garages, and many prominent American cars are well represented. The Cameron Automobile Company has the Stevens-Duryea, Cadillac, Franklin, and Buick; the Dallas Novelty Manufacturing Company, the Reo and Baker elec-

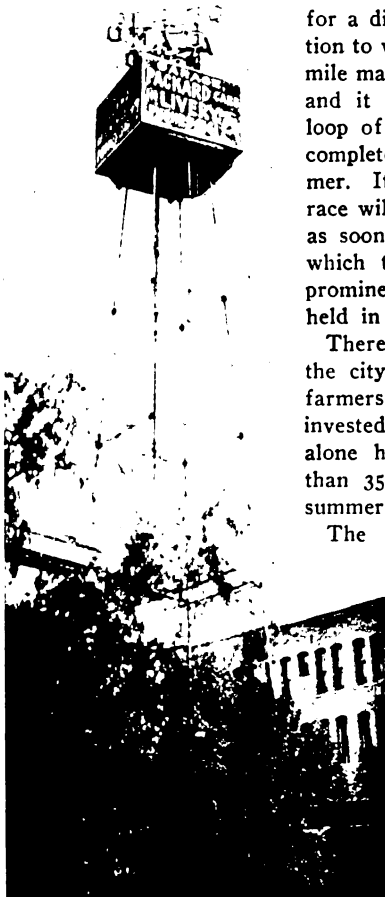

How One Texas Firm Advertises.



trics; and the Maxwell-Briscoe-Handley Company, representing Maxwell interests as a branch house. The Studebaker Brothers Company also have a representative of their own here, but do not maintain a garage.

#### Galveston Presents But a Limited Field.

GALVESTON, TEX.—When the fact is considered that the entire island upon which the city of Galveston has been built is of sand, and there are no bridges on which automobiles can run

connecting it with the mainland, it is apparent that the area of travel open to a car is extremely limited. This is made even more so by the fact that many of the city streets are at present impassable owing to the work of raising the grade which is being carried on. Consequently, the only place to run an automobile is on the paved streets, as once off these the sand is very loose and deep. There is naturally not much demand for cars here at present. When improvements now in progress are completed the market will improve greatly.

## AUTOISTS PROGRESSIVE IN THE GULF STATES

MOBILE, ALA., May 10.—It is difficult to conceive of more adverse conditions for autoing than exist in the southerly portion of the Gulf States, yet this city can boast of no less than 200 cars, despite the fact that it is hardly possible to drive a machine 100 miles without submitting it to an overhauling process to relieve it of the great quantities of sand that find their

population that is almost 60 per cent. negro, yet while the per capita wealth of the white inhabitants is comparatively low, it can boast of almost 400 automobiles, though there is hardly a road outside of the city limits that can be dignified by the title. In fact, they are almost impassable, except in the direction of Baton Rouge. A movement is on foot looking to a good roads propaganda, but as yet it is still in embryo.

Even in the city itself, driving is limited to comparatively few streets, such as Canal and St. Charles, where the going is good. Most of the others impose a test on a car that few owners would care to submit it to, speeds of more than a few miles an hour being impossible over these streets, owing to the nature of their pavement, which consists of large stone blocks that were presumably on a level when originally laid, but which have been permitted to fall into such a state of disrepair that scarcely two are any longer in the same plane, so that driving over such a surface, even at the lowest speed, would be apt to rack a car badly. There is a club here, of which Samuel Stone is secretary-treasurer.



Mobile Auto Company's Garage, Mobile, Ala.

way into every recess, regardless of the precautions taken to prevent it. The streets of Mobile are favorable for automobiling, but, even if it were a very much larger city than it is, its confines would not make a very ample field for the operation of a car. Once outside the city, there is nothing but sand, and it makes very hard traveling.

Autoists are progressive here, nevertheless, as a club is just being organized. G. J. Hartwell is the secretary and treasurer, and it is quite probable that H. H. Wefel will be elected president.

Quite a number of the well-known makes of cars are represented here and there are several good garages. The Southern Automobile Company maintains a modern garage and handles the White, Pierce and Buick; while the Mobile Automobile Company, which also has a garage, represents the Stoddard-Dayton, Mitchell and Glide. Bloch Brothers handle the Pope-Toledo, Pope-Hartford, Pope-Tribune, and National electric; while Gemthorpe & McKeon have the Maxwell line and run a garage.

Dealers state that the demand for automobiles in this section is almost entirely dependent upon the state of the lumber market, and as there has been more or less depression in the latter during the past few months, trade has not been active, though agents in Mobile are looking forward to a good season, as it is anticipated that conditions will become more favorable in the near future.

#### Crescent City Boasts Many Cars but No Roads.

NEW ORLEANS, LA., May 11.—This city forms one of the most striking examples of the introduction of the automobile in the face of adverse conditions that is to be found anywhere in this country. Here is a city of less than 300,000 people and with a



A Glimpse of Bienville Park, Mobile, Ala.

Quite a number of cars are represented here, and though agents report that business has been dull during the past few months, it is said to be picking up much better now. The Glide Motor Car Company handles the Glide, Ford, and Regal; while the Abbott Automobile Company has the Packard, Olds, and Buick, and maintains a garage, as does also the Automobile Company, representing the Locomobile. The only other garages are those of the Independent Auto Company, which handles the Stoddard-Dayton; M. Zilberman, and the Central Garage Company, both of the latter maintaining garages, but not representing any makers. Other agents are the Crescent City Auto Company, handling the Cleveland, Northern, and Palmer; Abner Powell, who handles the White, and H. A. Testard, who has the Cadillac and Pope-Toledo. Just as the state of the lumber market is the governing influence in southern Alabama, the demand for sugar and cotton has much to do with the purchase of automobiles here, and the fact that planters have been holding their cotton for better prices serves to explain the recent dullness.

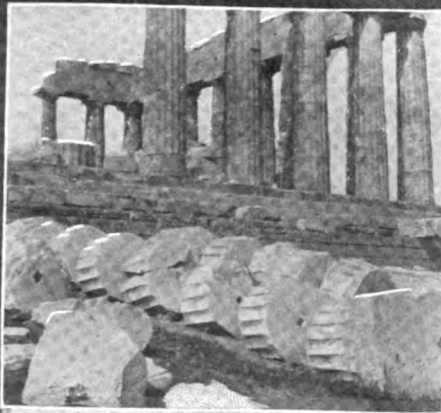

Broken Column at Parthenon



King's Palace



Stoa of Attalos

# Autoring Among Antiquities

Glidden in Greece



Museum at Athens



Lykabetto's Hill - Temple Jupiter Olympus

ALMOST 1,000 miles were covered by Mr. and Mrs. Charles J. Glidden during their stay in Greece, which was terminated on April 16. Their pilgrimage in that land of classical lore was made from Piræus, around Athens to the plain of Marathon, to Tatoi, Thebes, Eleusis, Delphi, Nauplia, Mycenæ, Tyrius, Epidaurus, Corinth, and minor points famous in times long past. Greece has many attractions for the automobilist, although the roads are somewhat limited, and generally bad, but well graded. Of course, the scenery is superb to the antiquarian.

There are about thirty automobiles in Greece at the present time, mostly in Athens, and gasoline costs sixty cents a gallon—a serious handicap.

Mr. and Mrs. Glidden arrived in Paris May 10, after a tour of 3,831 miles in Egypt, Syria, Greece, Italy and France. They have now completed 46,123 miles of their 50,000-mile tour, and have traversed 14,000 towns. The next trip will comprise Algeria, Tunis, Norway, Russia, Cuba and South America. "Automobiles are still an object of curiosity in Turkey," says Mr. Glidden, "but their importation is now authorized by an imperial irade, and permits granted to two firms to establish an auto service in the interior, which will be running regularly within a short time.



Acropolis. Temple Jupiter Olympus



Parthenon



Greek Church



Mars Hill



Theatre Herodes Atticus. Parthenon on hill

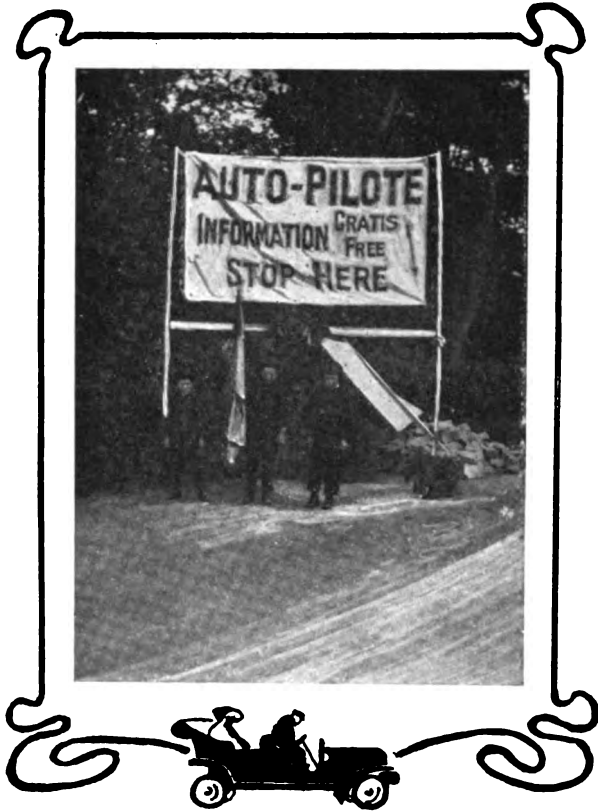

HERE'S a French idea, workable in any large town: Every automobilist knows the difficulty of making his way through a strange town, particularly the large, populous places which cater to automobile tourists. Whether one is simply passing through, or proposes to lunch, sleep, or dine, it is annoying to have to poke along, first up one street and then down another, in the vain hope of tumbling by chance into one's hotel, only to finally land in some garbage heap away out on the other side of the town.

The average "native"—possessed often of the best intentions—more often puts one wrong than right, whereas three or four small boys, properly instructed as to the kind of information an automobilist *en tour* really wants, could point out the best way through a crowded town, and thus enable the man in the car to avoid many undesirable, and perhaps dangerous pitfalls, such as badly paved streets, dangerous level crossings—and police traps, too. They could indicate the best and shortest route to one's hotel, the garage where one might want to purchase supplies, the post and telegraph offices, etc.

A seat on the running board, and say a fee of ten cents, would be the small boy's charge, and he would thus by a natural process of evolution turn his fellows into friends of the automobilist, instead of the stone-throwing antagonistic opponents that they mostly are at the present time. As a profession of the youth of the land, that of "auto-pilot" should rival that of golfer's *caddie*, if this idea is followed out generally.

At Dinard, one of Normandy's fashionable watering places, the plan has already worked well, and this season may be expected to find the idea largely developed here and in other likely places as well. Why not?

### A MODEL AUTO TOUR IN EUROPE.

By RODNEY OGILBY.

Each Summer witnesses an increase in the number of Americans automobiling over the splendid European roads. Paris is generally chosen as the starting-point, and so many tempting routes stretch away in all directions, like the spokes of some Titanic wheel, that it is no easy matter to choose between them.

Below this outline is a route which combines perhaps as many and as varied attractions as it is practicable to devise in a tour

of its length—the level and beautiful reaches of the chateau district, the magnificently scenic course of the Savoy Alpine-land, the smiling plains of Piedmont and Lombardy in Italy, and a glimpse of the lovely Italian Lakes. The tour ends at Aix-les-Bains, where the hotel and garage accommodations for visitors planning a lengthy stay are unsurpassed.

From Paris, the first day's run takes us to Orleans, a hundred miles. The route lies through Fontainebleau, with its far-famed castle and forest, and here lunch may comfortably be taken. Orleans itself is an interesting town, made famous by its associations with Joan of Arc. It is an Old World little place, with its Cathedral and quaint Town Hall, and has a choice of two or three reasonably good hotels.

Blois, forty miles below Orleans, may be regarded as the gateway of the chateau region, and Tours, forty miles farther still, is its center. At Tours, several days may be profitably spent, each with its interesting auto-excursion in this attractive neighborhood.

Touring now southwestwardly, we run on by Bourges and Moulins to Vichy—a pleasant two-day, 200-mile run over fine roads. Vichy is a lively little resort, and a good place for another brief stay. Then comes Lyons, a hundred miles farther; and, following that, Grenoble, seventy-five miles, where the level part of the tour ends for a time.

Grenoble is superbly situated, and in its vicinity are some extremely fine hill courses—roads winding into the heart of Alpine scenery, climbing frightful precipices with uniform and easy gradients, and invariably in the pink of condition, as are all French roads. Close by, too, is the venerable monastery of the Grande Chartreuse, where the unrivalled liquer used to be distilled until the silent Trappist Brothers were expelled and took refuge in Spain.

From Grenoble, a spin of another seventy-five miles takes us to Briançon, and sixty more to Turin. This is a route of fine views, with some of the most striking peaks of the Italian Alps continually in sight. Turin will be found a trifle warm in Summer, but the sensation of heat can be mitigated by taking a little glass of its well-known vermouth. The hundred-mile ride to Milan, also along the flat, fertile plains, may prove rather warm, but Milan itself will offer ample compensation in its numerous sights, its cool cathedral, and its airy and gay galleria. From Milan, a delightful day's trip should be made in the auto to the Certosa di Pavia.

Now you turn northward, and speed up to Como, perhaps the most captivating of Italian lakes. Next should come Lake Maggiore, reached on its western side at Pallanza, by way of another pleasing spot, Varese. Pallanza is a hundred miles from Milan. The great diligence highway of the Simplon, now just superseded by the new railroad, runs from Pallanza to Domo d'Ossola, whence we strike southwest again, by way of Biella, to Aosta, a hundred and sixty miles. Now begins some more fine hill roads, as the motor pushes on to Pré St. Didier, and then to one of the finest view resorts in the Southern Alps, Courmayeur. This mountain village, a favorite spot with Italians, beloved by the late Empress of Austria, but little visited by most American travelers, lies almost at the foot of the southern precipices of Mont Blanc, whose huge bulk, towering above the Allée Blanche between, is far more impressive as seen from this side than from Chamonix.

Finally, the route leads on out of Italy, high over the pass of the Little St. Bernard, and down through the French military post of Bourg St. Maurice, to Aix-les-Bains, a hundred and fifty miles from Aosta.

Some of the hills, especially those on the latter part of this attractive itinerary, are somewhat steep, and an anti-skidding tire and a powerful brake should be used in the descents. On the mountain routes the chauffeur should not indulge himself in high speeds at places where the prospect ahead is interrupted by sudden turns in the road. Carts and other slow-moving vehicles are constantly to be met or overtaken, plodding stodgily along, and one never knows what may be suddenly encountered.

# Head Dressings of the Fair Autoist



Picturesque Scarf Hoods Are Popular and Effective.

TIME was, and not so many years ago, when the crumpled rose leaf that marred the happiness of the fair automobilist was the lack of wind-resisting headgear. Her cry to the milliners, "Make for me a hat that will stay firmly upon my head during a swift run and I will reward you with the half of my pin money," has finally been answered. So multiform, indeed, are the designs now seen in the shops that it would seem as though any woman—whatever her complexion, facial contour or apparent age—might readily find suitable motoring headgear.

Straws deserve first place at this season, and among the finer weaves are medium-sized shapes in brown, burnt orange and black, these of the modified English walking and boat order which will stand considerable trimming in the form of big buckles, coq plumes and wings. Such shapes are exceptionally becoming to women past their first youth or those having strongly marked features.

Coarse and fine straw braids employed alternately are most effective. This idea is pleasingly developed in the shape of a medium-sized navy blue boat hat, having a rather high, square crown with four distinctly blocked upper corners, and trimmed solely with braided strands of self-colored taffeta. Chiffon folds of the same tint with a black outlined satin border are draped about the crown from front to rear, then drawn forward and tied beneath the chin, so that trimming and veil are practically in one piece.

Because of the protection afforded by the omnipresent veil some exceedingly tiny hats are used for autoing. In this class are the miniature Alpines of fine and coarse natural colored straws, their deeply indented crowns and closely fitting brims trimmed with black velvet and black birds. These look immensely *chic* when perched upon masses of puffs and curls, as do also the envelope hats with their sharply upturned left brims distinctly outlined with a contrasting binding, and the little perky bows fluttering against the rather flat crown. Of the same order are the small fine straw hats, brimless at back and slightly pointed over the brow, that are bound and banded broadly with dark kid matching the small rosettes which decorate the crown and the bandeaux which tilt them ever so slightly to the right side of the head. Leather and kid bands and rosettes are a feature of the trimming of the

rougher type of hats, meaning those used for long and hard tours of several weeks' duration. In this event the trimmings match the strappings of the corded rep or rubberized pongee motor ulster.

Panama hats of modest dimensions and tailored finish are certain to be much worn during the Summer. Their popularity is largely due to the fact that they have flexible brims which may be rolled in whatever direction is most becoming to the individual face. They are trimmed in various ways. At present many Japanese scarfs are employed in their adornment. These are drawn loosely about the crown from brim almost to apex and knotted at the left side toward the back so that the fringed ends drop over the hair. When the inch wide bands are Yale blue, Harvard red, or whatever great university ranks most highly in the wearer's esteem, the ribbons are drawn tightly about the crown and secured invisibly, or they are joined with big black leather buckles which give rather a distinguished air to the hat. With the advent of really warm weather, these useful Panamas may be cleaned or bleached and decorated more seasonably with black, brown, or white chiffon choux and loops, supplemented with pretty dove wings.

Crowns are of diversified shape with the Tam O'Shanter version rather in the lead. This is owing to their non-crushable characteristics, and the fact that the narrow, slightly inverted brims render them wind resisting. Moreover, Tams require scarcely any trimming beyond the twisted silken band, which never gets in the way of the veiling scheme.

Satin motoring hats have come into being with the craze for fabric-covered headgear, and in their dip-brimmed, peak-crowned form are deemed immensely smart, particularly for use with the rubberized satin coats. They are usually decorated with yard-long scarfs of self-colored soft silk having deeply bordered fringed ends of contrasting hue, knotted in single bows at the left side, slightly toward the back.

Brimless turbans that dip at the back are not universally becoming, as there is nothing to relieve the outline severity at sides and front. However, they are considered ideal wind reuffers, and with some women that is still the chief motive.

Visored caps similar to those worn by men are used almost exclusively by some women, as they are to be found in all the popular tints in pongee and mohair, in cloth plaids and mixtures, and in black, navy, tan and gray leather. Such shapes certainly lend a trim effect to feminine motoring garb, and the wide visor protects the eyes from the sun when no veil is worn.

Bonnets with brims slightly depressed over the brow are returning to favor with motoring headgear. In their present form they are a boon to elderly ladies whose dignity forbids them to adopt the frivolous looking Alpines and Panamas as well as the unspeakably co-



Traveling Veil Tied Four-in-Hand.



quettish toques so popular with the younger generation. Crush felts precisely like the "bush rangers" used for fishing and hunting excursions by the stronger sex are affected by very young girls who go in for the daringly unique. When they have poked their pink fingers into the high crowns



A Practical Garb That Is Serviceable.

to make them bowl shaped and tied the flapping brims over their ears with broad ribbons the effect of the improvised motoring hat is dangerously demure.

Little hoods which strongly resemble night caps are made of mohair, satin and kindred rubberized fabrics, and designed to be buttoned into the inner side of the hat crown and let down whenever it is desired to protect the hair and the ears from dampness. Their lower edges are doubly shirred upon a ribbon which ties beneath the chin and over this may be turned the coat's storm collar so that only a small portion of the face need be exposed to the elements.

Attachable hoods are exceptionally popular with both men and women. Some of them, arranged to entirely cover the hat, are friar shape, others are tight-fitting like a knight's helmet and vastly uncomfortable, despite a generous number of air holes. Practically the best hood is wired to stand slightly away from the head and provided with a waist length shoulder cape, so that when seated the wearer is well protected from the rain.

To drape the automobile veil in an eminently becoming and entirely adequate manner is a task "not to be undertaken lightly and unadvisedly." No matter what may be the size of the hat, the veil should be three yards long and at least half a yard wide. As every woman knows, the first mission of the veil is to become the wearer and the second to protect the face and hair from dust and sun. To do this the back as well as the front of the head must be thoroughly covered while one is riding, but the gauze so arranged that it may be thrown aside quickly. To effect this, the veil would best be in two distinct sections, joining for the space of a finger's length over the hat crown, the two back ends being brought forward and knotted beneath the chin, and the others crossed at the back and allowed to float at will.

Veiling materials were never more bewitching. The crepe chiffons and chiffon cloths which wear interminably are to be found in all the desirable colors finished with plain, hem-stitched or embroidered borders. Some of them have self-colored satin borders attached with white or black chain stitching. These borders are of three types. One shows a succession of graduated stripes, another a half-inch edging surmounted by a four-inch band and a third simply the very broad edge.

Self-colored disks finish many of the new veils. They are often run across the ends merely and are of uniform size, or they entirely border it in rows ranging from nickel to half-dollar dimensions.

Plaided veils are in gauze, sewing silk and chiffon of various tones, but the preference is for brown of a reddish cast, which does not attract the sun's rays, and for gray of a pale tone, which is supposed to become the average complexion. Navy blue is also in high favor, and, like green, is considered restful to the eyes, but smartest of all are those veils of pure

white with wide borders of shaded tan or porcelain blue. The veil with a mica mask is worn by numbers of enthusiasts. This mask is about four by sixteen inches in size and set into the chiffon veil with machine stitching.

**Picturesque Scarf Hoods.**—Rainproof satin is much employed for the voluminous scarf hoods used as storm protectors of small hats worn with the English plaided tweeds and mixtures, as well as with the lighter rubberized fabrics. These hoods are of full width satin, shirred on a rubber band and drawn over the head, closing beneath the chin with shirings and large buttons, whence the ends fall over the shoulders or to the waist. Chiffon mask veils, shirred across the front of the hat, fall loosely over the face.

**The "Bride's" Traveling Veil.**—Women who eschew the all-enveloping motoring coat in favor of the trimly tailored mo-hair or serge coat and skirt costume of the fashionable chevron stripe effects are adopting the enormously long and wide bridal motoring veils. These are usually of the handsome satin bordered white, gray or champagne chiffons, three by one and a half yards in size. One side is so draped over the front of the hat that it will protect the neck, and the remainder over the back of the hat, the ends crossed at the nape of the neck, then drawn loosely forward and knotted four-in-hand manner below the throat. When not in the car the wearer allows the veil to flow loosely from the back of the hat precisely as does the conventional wedding veil.

**Practical Automobiling Garb.**—Clan plaid silk, rubberized, is extensively used for automobile coats, which in their latest development show the singly box-plaited back, the narrow side gores and the wide arm-sized sleeves, slightly gathered all around. Broad biased bands simulating round yokes, punctuated with silk-covered, metal-bound buttons are much in vogue and turned-over collars and turned-back cuffs are deep and pointed rather than straight. With the dark-toned clan plaids are worn bordered chiffon veils matching the grounding of the coat. The veil pictured is side plaited at one end, drawn in over the crown's top toward the back and secured by the shaped straw band. The remaining end is then drawn from left to right over the face and attached to the back of the hat.

**Adaptability of the Duplex Veil.**—In no way is the duplex of four-ended veil more valuable than when it is necessary to veil a hat of unique shape, such as the pictured modified Gainsborough with irregular brim and dented crown. The joining shirring of the rear section is brought to the front of the crown and the ends drawn over the ears and knotted beneath the chin, while the forward section is draped over the face and the ends crossed at the back, thus firmly securing the hat. In this instance the natural colored straw of the hat matches the hue of the satin insets of the collar and cuffs of the taffeta coat.



Readily Adaptable Duplex Veil

**MAINE BUYING AUTOMOBILES.**

PORTLAND, ME., May 18.—Automobiles continue to grow in popularity in Maine, and it is now estimated that there are cars enough in the State, owned here and registered at the Secretary of State's office in Augusta, to represent an outlay of considerably more than \$2,000,000. The total number of automobiles which have been registered in Maine since the law went into effect in 1906 is 2,443, and the number since the beginning of the current year, up to May 1, is 205. The total number of operators' licenses issued since the law went into effect is 2,847, and the number during the current year 215. The total number of motorcycles registered in the State is 259 and the number registered to date in 1908 is 31.

The movement for good roads in Maine is going steadily along, and from all indications, the stretches of bad places in the State's highways will in a few years be wholly eliminated. Visitors from outside of Maine are already remarking upon the improved condition of the roads. Highway Commissioner Paul D. Sargent of Augusta has been holding a series of meetings at many points about the State where the good roads question has been discussed. Farmers, selectmen and others interested have never failed to attend these meetings in large numbers and good results have always followed. The meetings are of an educative nature, open to discussion and many valuable points on road building and the construction of State roads have been gained in the course of his instructive campaign.

By a law of the State, any town may receive an appropriation for a State road, provided it will also appropriate a sum for the building and maintenance of it. The city of Portland the present year will receive \$200,000 and a road has been laid out that will be on the direct route of tourists going through the State to points on either border.

**SLIGHT DECREASE IN MARCH EXPORTS.**

Though the value of the automobiles and parts exported from this country during the month of March, 1908, is slightly less than that of the corresponding month of 1907, the figures being \$545,347 for the latter, and \$539,388 for the present year, statistics issued by the Department of Commerce and Labor show that the gain during the past three years has been very steady and substantial. For the nine months ending with March, 1906, the total was \$2,064,874; in 1907, this increased to \$3,418,593, while the present year's figures are \$3,601,211. A noticeable feature of the returns for the month of March, 1908, is an increase in the value of automobile parts exported from \$51,922 in 1907, to \$72,941. Despite the drop in the total, substantial increases are apparent to such automobile manufacturing countries as Great Britain, France, and Italy, the English imports advancing from \$146,621 to \$156,820, while the French took \$81,083, as compared with \$65,813 the same month a year previous, and Italy's total jumped from \$27,024 to \$45,842.

**THIS FARMER USED AUTO TRUCK.**

HARTFORD, Conn., May 18.—Even the farmers are taking to automobiles for utility purposes. A case in point is that of a truck gardener of a small town a short distance from Hartford. He uses a two-cylinder air-cooled Knox truck and hauls a load of produce that would put a horse to shame. The roads traversed are very good, so he has nothing to fear in this direction. Speed is a factor in that it makes a lot of difference whether he reaches the city market early or late, and with the truck he gets there in less time than was formerly necessary for the horse outfit.

**"TAXILESS" TAXIMETER LATEST DEVELOPMENT**

To meet the tremendous demand for taxicabs now existing in New York City, taximeters are being stuck on all kinds of cars, but the most amusing development noted was an improvised "taxi" on which the meter had no driving connection.

**THE AUTOMOBILE CALENDAR.**

**AMERICAN.**

**Shows and Meetings.**

- June 25-27.....—Detroit, Third Annual Summer Meeting of Society of Automobile Engineers.
- Dec. 31-Jan. 7....—New York City, Grand Central Palace, Ninth Annual Automobile Show, conducted by the American Motor Car Manufacturers' Association, with Exhibits by the Importers' Automobile Salon, Inc., Alfred Reeves, general manager, 29 West 42d St.
- January, 1909....—New York City, Madison Square Garden, Ninth Annual National Show of the Association of Licensed Automobile Manufacturers. (Exact date to be announced.)
- February, 1909....—Chicago, Coliseum and First Regiment Armory, Eighth Annual National Exhibition, National Association of Automobile Manufacturers. (Exact date to be announced.)

**Race Meets, Hill Climbs, Etc.**

- May 23.....—Albany, N. Y., Hill Climb, Albany Automobile Club.
- May 30.....—Boston, Readville Track, Race Meet, Bay State Automobile Association.
- May 29-30.....—Minneapolis, Minn., 300-mile Endurance Run, Minneapolis Automobile Club.
- May 30.....—Bridgeport, Conn., Sport Hill Climb, Bridgeport Automobile Club.
- May 30.....—Wilkes-Barre, Pa., Giant's Despair Hill Climb, Automobile Club of Wilkes-Barre.
- May 30.....—San Francisco, Endurance Run under the auspices of the Automobile Dealers' Association.
- June 5.....—Jamaica, L. I., Straightaway Time Trials, Long Island Subway Celebration Committee, assisted by Long Island Automobile Club.
- June 6.....—Worcester, Mass., Dead Horse Hill Climb, Worcester Automobile Club.
- June 24-27.....—Chicago, 1,200-mile Reliability Run, Chicago Motor Club.
- July 4.....—Lowell, Mass., 240-mile Road Race, Lowell Automobile Club.
- July 7-8.....—Buffalo, N. Y., National Convention of the American Automobile Association.
- July 9.....—Buffalo, N. Y., Start of the Fifth Annual A. A. A. Reliability Touring Contest.
- Sept. 5-9.....—San Francisco-Los Angeles Reliability Run, Automobile Dealers' Association of San Francisco.
- Sept. 14.....—Chicago, Annual Economy Run, Chicago Motor Club.

**FOREIGN.**

**Shows.**

- May 17-31.....—Austria, Budapest Automobile Show.
- May 17-June 2....—Moscow, Russia, International Automobile Exposition, Automobile Club of Moscow.
- December.....—Paris, Eleventh Annual Salon de l'Automobile, Grand Palais, Automobile Club of France.

**Race Meets, Hill Climbs, Etc.**

- May 1-31.....—Automobile Taxicab Competition, France, Automobile Club of France.
- May 31.....—Russia, St. Petersburg to Moscow Race.
- June 1-18.....—Reliability Trials for Pleasure Cars, Automobile Club of Great Britain.
- June 14.....—Mount Cenis Hill Climb, for Voiturettes.
- June 9-17.....—Touring Competition for the Prince Henry of Prussia Prize, Germany, Imperial A. C.
- June 15-19.....—Scotland, Scottish Reliability Trials.
- July 6.....—Voiturette Grand Prix, Dieppe Circuit (Automobile Club of France).
- July 7.....—Grand Prix of Automobile Club of France, Dieppe Circuit.
- July 13-17.....—Ostend, Belgium, International Race Week, Automobile Club of Ostend.
- July 20-30.....—Ardennes Circuit Races and Coupe de Liedekerke, Automobile Club of Belgium.
- Aug.....—France, Coupe de la Presse, Automobile Club of France. (Exact date to be announced.)
- Aug. 29-30.....—France, Mont Ventoux Hill Climb, Vauclusien Automobile Club.
- Sept. 1-8.....—French Voiturette Contest, auspices of "L'Auto."
- Sept. 6.....—Bologna, Italy, Florio Cup Race, Automobile Club of Bologna
- Oct. 11.....—Berlin, Germany, Gordon Bennett Balloon Race, Aeronautical Club of Berlin.



Vol. XVIII

Thursday, May 21, 1908

No. 21

THE CLASS JOURNAL COMPANY

Flatiron Building, Madison Square  
New York City

H. M. SWETLAND, President

EDITORIAL DEPARTMENT

A. G. BATCHELDER, Managing Editor  
R. F. KELSEY, Associate Editor C. B. HAYWARD, Engineering Editor  
W. F. BRADLEY, Foreign Representative

BUSINESS DEPARTMENT

A. B. SWETLAND, Business Manager  
LOUIS R. SMITH FRANK B. BARNETT  
W. I. RALPH, 1035 Old South Building, Boston, Mass.  
C. H. GURNETT, H. E. WESTERDALE, 1200 Michigan Ave., Chicago, Ill.

Cable Address - - - - - Autoland, New York  
Long Distance Telephone - - - - - 300 Gramercy, New York

SUBSCRIPTION RATES:

United States and Mexico - - - - - One Year, \$3.00  
Other Countries in Postal Union, including Canada - - - - - One Year, 5.00  
To Subscribers—Do not send money by ordinary mail. Remit by Draft,  
Post-Office or Express Money Order, or Register your letter.

FOREIGN SUBSCRIPTION AGENTS:

ENGLAND:—W. H. Smith & Sons, Ltd., 186 Strand, London, W. C., and all their  
railroad bookstalls and agencies throughout Great Britain; also in Paris at  
248 Rue de Rivoli.  
FRANCE:—L. Baudry de Saunier, offices of "Omnia," 20 Rue Duret, Avenue de  
la Grande Armes, Paris.  
GERMANY:—A. Seydel Mohrenstrasse 9, Berlin.

Entered at New York, N. Y., as second-class matter.  
The Automobile is a consolidation of The Automobile (monthly) and the Motor  
Review (weekly), May, 1902, Dealer and Repairman (monthly), October, 1903,  
and the Automobile Magazine (monthly), July, 1907.

Copies printed in 1905	- - - - -	730,000
" " in 1906	- - - - -	791,000
" " in 1907	- - - - -	888,900

POPULAR VOGUE OF THE TAXICAB.

What has been constantly predicted for the automobile for several years has now come to pass. The taxicab has arrived. True, there have been more or less evidences of the gasoline-driven public service vehicle during the past year, particularly in New York City, but both the pioneers as well as a very large percentage of the cars that have been in use from the first have been of foreign origin. Now the American maker has awakened to the possibilities of the town type of vehicle for either public or private use, and it is safe to say that there is scarcely an established American manufacturer to-day who has not tried his hand at turning out a few taxicabs.

Some of these did not require any great exertion on the part of their makers, to be sure, as they represent nothing more than one of the latter's stock chassis with a very much ready-made-looking landaulet body perched upon them. Others are special designs throughout that represent a great deal of work and study devoted to the problem of turning out a vehicle for this most strenuous form of service.

As conditions are at present, it is possible to reap large gross returns from the running of anything in the shape of a power-driven cab, but it is evident that only the vehicle which is built for this service can stand the racking and show a net return on the investment at the end of the year. For which reason, it is further apparent that many of the improvised cabs now running will fade

from view before long and only those of sufficient merit to stand the test will prove dividend payers in the end. However this may be, it is certain that the present vogue of the taxicab will result in popularizing the automobile, to a greater extent than could possibly have been done in any other way in the same period of time. A highly interesting development in connection with these little vehicles has been their official inclusion in the commercial vehicle tests now being held in France. On this occasion they are being limited to alcohol as fuel.



ALLOY STEEL FOR AUTOMOBILE TOOLS.

A manufacturing opportunity that it is somewhat surprising accessory makers have not taken advantage of, concerns the demand that it would seem might be created for alloy steel tools. No automobile user of experience needs to be told that any investment in cheap tools is likely to be money worse than thrown away, nor does he fail to realize that the attainment of the highest possible quality in many of these useful articles is a problem as exacting in its demand as anything in the whole range of engineering.

Take the screwdriver, for example, on which ordinarily falls the brunt, not only of the most exacting sort of legitimate chiseling, wedging, punching, and driving operations, to which even the careful mechanic is sure to be forced by stress of circumstances to put it sooner or later. This tool in its width and thickness of blade is closely limited by the conditions of its normal use. Obviously, then, the only recourse is the objectionable and awkward sets of screwdrivers of many different sizes, or else the utmost possible improvement in the quality of the steel, which suggests at once that the finest alloy steels are none too good for an article that is now commonly made of altogether inadequate tool steel. What is true of the screwdriver applies equally to other tools, such as wrenches, spanners, and the like, the number necessarily carried making the matter of weight reduction alone an item of importance.



AUTOMOBILING'S WIDESPREAD ADVANCE.

When one glances through the list of events scheduled from one end of the country to the other—here an endurance contest, there a hill climb, and somewhere else a high speed race—he more accurately appreciates the widespread progress of the pleasurable necessity in these United States. Once upon a time to have suggested that soldiers in uniform could be utilized to guard the pathway for an automobile road race would have brought forth derisive smiles and prompt refusal. When one reads that in Massachusetts, Connecticut, and Pennsylvania hill climbs are scheduled with military guarding, and even in far away Oregon a road race is to have soldier-boy policing, and then, with Savannah still fresh in mind, the conviction is driven home that the battle of the automobile is practically won and its future progress will be attended with a great deal less opposition than has been shown during earlier and more unreliable periods. Certainly the motor-driven vehicle is demonstrating the reason of its being just as rapidly as the manufacturers distribute their product, which now finds equally great demand in city and country.

## VANDERBILT CUP RACE SEEMS CERTAIN ON LONG ISLAND

THE next Vanderbilt Cup race seems certain to be run on Long Island. This fact became known through press dispatches from Worcester, Mass., telling of the awarding to the Hassam Paving Company of a contract for the building of a 60-mile stretch of roadway for the Long Island Motor Parkway, Inc., the completion of 10 miles of the roadway by October 1 being made a part of the contract.

When the bids of Savannah and other cities for the race have come up for discussion, Chairman J. D. Thompson, of the A. A. A. Racing Board, has invariably stated that it would be the policy of himself and his associates to hold the race near New York, provided that a course, either fenced in or guarded by soldiers, could be secured. The Racing Board, in announcing the rules for the Vanderbilt race, embodied in its bulletin the statement that the date and course would be announced on or before July 1. The chairman now reiterates this statement.

It can be safely assumed that adjoining roads will be made use of to enable the employment of whatever straightaway stretch of the Long Island Parkway may be available for the race. All statements as to the location of the stretch to be

used, the details of its arrangement for racing purposes, and the building of loops for making the turns at either end, are, of necessity, at present mere guesswork.

To hold the Vanderbilt Cup race in the metropolitan district is generally considered logical and desirable. It had its origin in New York. The donor of the trophy competed for is a New Yorker. The representatives of the foreign cars, which comprise a majority of the contending forces, are also centered in New York. The metropolis of the country is its most important news center, and able to give to the contest the greatest possible publicity. In view of all this, it is naturally a matter of general gratification to learn that a course appears to have been finally secured on Long Island, the world-famed arena of former contests for the Vanderbilt Cup.

The figures supplied by Capt. William E. Hassam, of the company, place the total of the contract at \$2,000,000. In rushing the 10-mile racing stretch to completion, he says that 30 car-loads of cracked rock a day will be required. The contract was awarded following the laying of a sample stretch of roadway on Mr. Vanderbilt's Long Island estate.

### FRANCE'S PROTEST OF VANDERBILT RULES.

Automobilists interested in racing, who are in a position to understand the ins and outs therewith involved are somewhat amused at the evident purpose of a certain A. C. A. contingent to "aid" the Vanderbilt Cup Commission in securing entries for the big American race.

Assuming to act as correspondent of the A. A. A. in the somewhat loosely organized international association of clubs, the A. C. A. failed to notify the national body that it had been obligated in any way to conduct the Vanderbilt race according to so-called international rules.

It is also a matter of record that A. L. Riker, a member of the A. A. A. Racing Board, deputized by that committee to consult A. C. A. official records, reported that he could not discover any correspondence whereby that club had bound the A. A. A. to observe international rules in the conduct of the Vanderbilt event. In view of the fact that Mr. Riker is a member of the contest committee of the A. C. A., his report was accepted without question.

Though failing to supply any information concerning the meetings at Ostend and Paris, the A. C. A. contest committee, of which Robert Lee Morrell is the chairman, gives widespread publicity to a letter of protest from the Automobile Club of

France, taking exception to the "failure" of America to observe the so-called international rules to which the A. C. A. obligated (?) the A. A. A. in the running of the Vanderbilt race by its cup commission. Mr. Morrell also supplies for publication a copy of his letter sent to Jefferson deMont Thompson, chairman of the A. A. A. Racing Board and the Vanderbilt Cup Commission, notifying that official of the protest from France, and asking for prompt reply.

Interviewed, Chairman Thompson is quoted as follows:

"The Vanderbilt Cup Commission adopted its rules, with a full knowledge of the situation on the other side of the Atlantic, for reasons which seemed sufficient to it, and which were acceptable to the donor of the cup, W. K. Vanderbilt, Jr.

"I cannot exactly understand the reason for the Automobile Club of France making a protest. The club has had no official connection with the Vanderbilt Cup race for two years, and refused then to name an official team for the race. The entries that we had for the race were received from independent manufacturers and were made as individuals. The same is true of last year, when we had a number of entries for a race, and had to send them back. It will be true again this year. The status of the Automobile Club of France in the matter I fail to see, therefore. The rules are fixed, and will remain unchanged. The letters will be called to the attention of the Racing Board as a matter of courtesy merely. I also fail to understand why the protest mailed in France on April 18 should be delayed so long in reaching us."

## THOMAS, PROTOS AND ZUST ONLY REMAINING SURVIVORS

CABLES from Vladivostok to the New York *Times* are to the effect that everything was in readiness for the start across Siberia, to take place on Wednesday, May 20, these late advices also stating that the Zust will start with the Thomas and Protos. The Trans-Alaska-Siberian railroad has offered a prize of 5,000 francs to the car first to reach Tchita, while a similar prize has been offered by the Russian Automobile Club to the car first to reach St. Petersburg.

In addition to the confirmation of the announcement previously made that the De Dion car would be withdrawn at Vladivostok, it is now stated that the Zust has been formally withdrawn from the round-the-world race, thus leaving the American and German cars the two remaining contestants. Under the terms of the arrangement recently decided upon by

the French committee, the Germans have to allow the Thomas thirty days, so that while both will undertake the Siberian trip together, the Protos will be a month behind in point of time.

According to a cable to the New York *Times*, the Thomas car arrived at Tsuruga, Japan, en route for Vladivostok on Friday last, May 15, after a two-days' trip across the island.

### Godard Tells "Wonderful" Tales in Paris.

PARIS, May 10.—Another of the "brave" New York-Paris drivers has returned home, and is now thrilling his compatriots with stories of adventures in the wilds of the United States. Though he may not have seen much to the west of Chicago, Charles Godard has no lack of stories to relate on the round-the-world tour, which he and his Motobloc undertook so joyously. Stripped of their verbosity, they amount to "bad roads, bad food, scant hospitality."



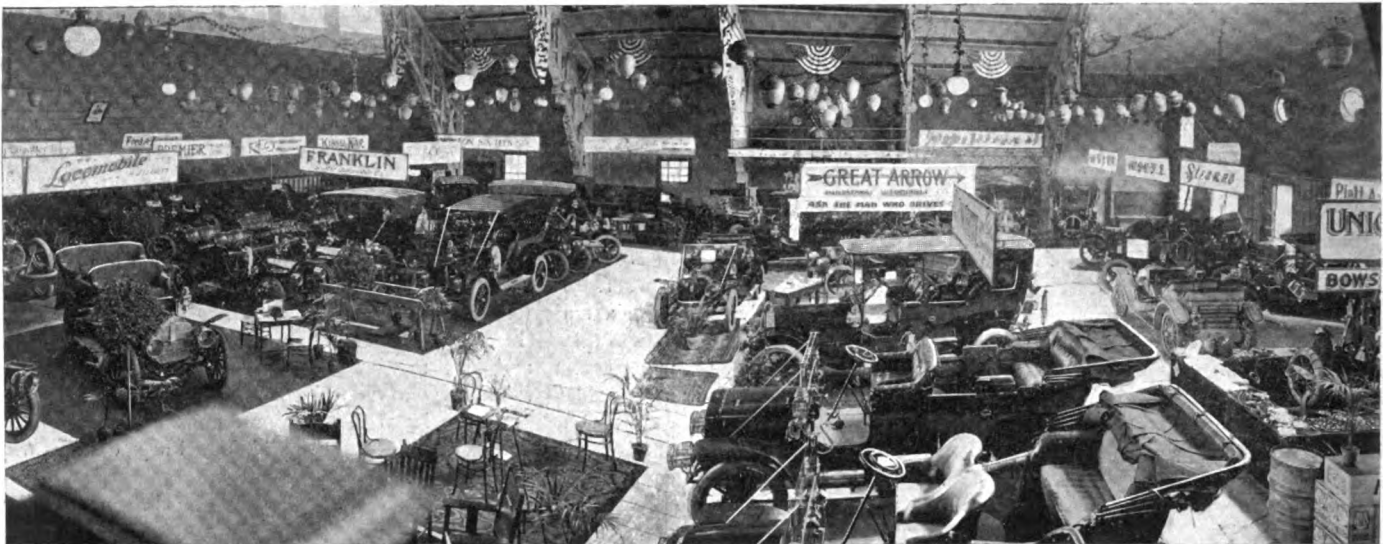

How Dreamland Rink Was Utilized by the Automobile Dealers' Association of Seattle, Wash., for Its First Show, April 22-25.

## TO HAVE MILITIA-GUARDED RACE.

PORTLAND, ORE., May 12.—During the Rose Festival week, which is an annual event here, Portland is going to show the country that successful road races may be held on the Coast, as well as in the East. Thursday, June 4, is the date set for the event, which is to be a 100-mile run of 7 laps, the latter measuring 14 miles each. There will also be a 50-mile race over the same course. Up to the present writing, there are no less than 56 entries for the big event, the majority of the cars being entered by the local representatives of the manufacturers, though there are a few private cars in addition.

E. Henry Wemme, a pioneer autoist of this city, has offered a \$500 silver cup to the winner of the 100-mile race, which will be run under the auspices of the Portland Automobile Club. The course will be effectively guarded by the Third Regiment, Oregon National Guard, under command of General W. E. Finzer and Colonel Charles N. McDonnell. The soldiers will be armed and in full uniform, and the Oregonians are setting out to show the country and the world at large that they know how to hold a big event by providing proper protection.

The course lies through a most picturesque bit of country adjacent to the city, comprising two of the main roads lined with fruit farms and suburban residences. It is a section easily

reached by the interurban service of the street car lines. Eastern drivers and agents now here, who have seen the Vanderbilt and Briarcliff courses, say that the roads selected here are equal to anything that has been used for the purpose in the East. There are quite a few sharp turns that are dangerous, but the work of widening the road at these points and providing a proper banking has already been undertaken.

The start and finish are to be at a grandstand two miles from the Twelve Mile House, which is run by Fred T. Merrill, an old-time bicycle rider. This stand is being erected by the Portland Automobile Club and is to have a capacity of 5,000 people. The course runs through Russellville and Gresham, but no controls will be required. It includes one six-mile stretch of perfect straightaway that is the finest roadway to be found anywhere in the West. Owing to the manner in which the land is laid out in sections, the course is practically a square along the base and section line roads. But in spite of this feature, it possesses the usual characteristics of a road racing course, in that it has a typical "S" turn, located immediately east of Gresham hill, and one or two very bad corners, the worst of which is situated where the Base Line road leads into the Russellville thoroughfare, while there are also several hills.

The Wemme Cup is offered for competition, and must be won three times in succession.



The "S" Turn on Section Line Road near Portland, Ore., which Will Test Chauffeurs' Skill and Nerve.



Climbing "Jacob's Ladder," in the Berkshires, a Hill Famous for Strenuous Experiences Among Automobilists.

## FROM ALBANY TO BOSTON IN ONE DAY ON THE A.A.A. TOUR

By LEON MYRON BRADLEY.

**A**FTER fifteen days of mud plugging, climbing mountains, plunging through small streams, making detours to escape steam rollers and torn up roads, filling up ditches with rocks, fence rails, and planks, and also speeding over mile after mile of the famous highways of Massachusetts—the Premier Pathfinder has laid out eight days of the 1908 A.A.A. tour, making a total of 1,059.5 miles, the odometer, however, showing 1,361 miles. The difference is the distance traveled by the Premier on wrong roads, etc. The eight days as now laid out are:

First day—Buffalo to Cambridge Springs.....	117.4 miles
Second day—Cambridge Springs to Pittsburg....	110.2 "
Third day—Pittsburg to Bedford Springs.....	106.4 "
Fourth day—Bedford Springs to Harrisburg.....	107.3 "
Fifth day—Harrisburg to Philadelphia.....	133.5 "
Sixth day—Philadelphia to Milford.....	132.0 "
Seventh day—Milford to Albany.....	158.5 "
Eighth day—Albany to Boston.....	194.2 "

The Pathfinder had laid out a route from Harrisburg to the Delaware Water Gap eliminating Philadelphia when ordered back to Harrisburg, a distance of 130 miles,—to lay out a new route from that city to Quaker Town.

The fifth day's run of the tour as mapped out will undoubtedly be one of the easiest of the whole tour. Leaving Harrisburg the route is along the Susquehanna river to Steelton and past the Steelton mills and furnaces and by the mammoth Pennsylvania Steel Works. The fifth day's run was the first that the six-cylinder Pathfinder was enabled to make any fast time, and it

was photographed beside a six-mule combination. It was the first day that we were blessed with sunshine since leaving Buffalo. The roads are excellent and are practically macadam the entire distance with the exception of a few stretches of clay. The clay road, however, is in excellent condition and fast time can be made by the contestants. The route selected is zigzag. It includes Marietta, Lancaster, Reading, and Pottstown, and is far superior to that which was laid out direct from Harrisburg to the "Gap." There are practically no hills to speak of, and the only drawback is over the Marietta-Lancaster pike, where many water-breakers predominate and about one-half dozen toll-gates will be passed through. The rubber raincoats, sweaters, and other heavy clothing were packed in the suit case, and replaced by the lightest of clothing and dusters. A limit of six or seven hours will probably be the maximum of this day's run. The tourists should begin to arrive at Philadelphia about 2 o'clock, which will give them ample opportunity to rest. The Quaker City Motor Club is enthusiastic because Philadelphia has finally been chosen as a stopover. The club's headquarters are in the Walton, where the tourists will remain over night and be entertained with a smoker.

One of the most picturesque runs is that between Philadelphia and Milford. This will take the contestants through Allentown, Bethlehem, Nazareth, Easton, and through the Gap. There are a variety of roads, but macadam predominates. The mud-plugging trip at this point turned into a dust-eating one, as very



Picturesque Country After Leaving Port Jervis, Near Unionville, N. Y., en Route to Goshen.



Coming Up Butterback Mountain in the Catskills.

little mud was found, but much time was lost in crawling over recently laid trap rock, dodging steam rollers, and mule teams loaded with road-making material. The scenery through this part of Pennsylvania will well repay the participant in the tour for his trouble. Few spots in America vie with Delaware Water Gap in picturesque effect, and the mountainous surroundings are complete in harmony and effectiveness. Much has cer-



Both Pathfinder and Occupants Stop for Drink.

tainly been gained by the decision to go around New Jersey instead of across.

From Philadelphia to Three Churches, a distance of 93 miles, the tourist will find some of the best highways in Pennsylvania. It is said that all the roads which are now torn up and in process of construction will be finished before the tourists arrive in this section. Several stretches of brand new macadam will have no water-breakers, but on the Allentown pike from Philadel-



Almost Stalled in the Mud Near New Baltimore, N. Y.

phia there is a great quantity of them. On this pike there are eight or ten toll-gates, the tolls ranging from 3 to 10 cents. If the route book is not closely followed, many of these toll-gates are liable to be overlooked, due to the smallness of the signs which are set in inconspicuous positions.

At Easton the course lies parallel with the Delaware river which is followed much of the way to the Gap. Three Churches is on a hill, and from it the Gap can be seen seven miles away, with beautiful intervening valleys. The scene is inspiring, and at each leap of the big six-cylinder the scenery grew better and more beautiful.

From Portland to the Gap, a distance of five miles, the road becomes very narrow and winding. On one side are great tow-



Approaching "Jacob's Ladder" in the Berkshires.

ering mountains with overhanging cliffs, while on the other is the D., L. & W. R. R., then the Delaware river, and beyond are other peaks. The two highest peaks which form the gap are Mt. Minsi and Mt. Tammany.

There is no question but that the run from Milford to Albany, a distance of 158.5 miles, will be one of the most trying

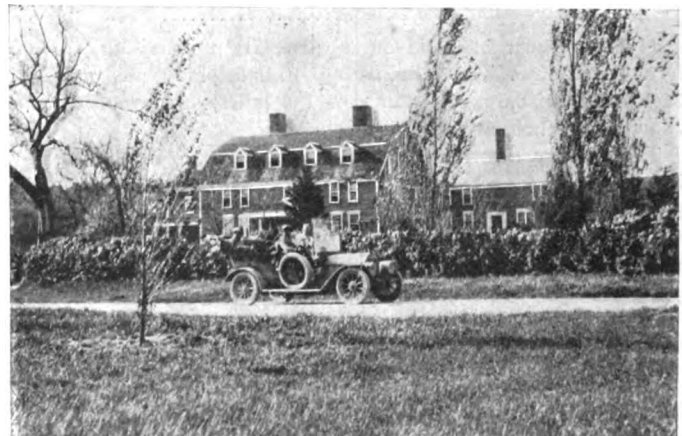

Longfellow's "Wayside Inn" at Sudbury, Mass.

of the fourteen days' contest. Up to Boston it is the hardest yet laid out. The principal towns through which the route goes include Port Jervis, Middletown, Goshen, Newburg, Kingston, Saugerties, Catskill, and Athens. The roads from Milford to Albany are over a combination of macadam, clay and dirt, interspersed with many twists and turns and steep hill climbing. The only speed trap which the Premier Pathfinder has encountered since leaving Buffalo is a mile south of Port Jervis after leaving Milford. At Milford we were warned by hotel proprietors and others that an obnoxious constable secured two dollars for each arrest over the best macadam roads between Milford and Port Jervis. Heeding the warning we crawled at a snail's pace over this course and were not bothered.



At Port Jervis the regions of oil, coke, coal, and steel were left behind, and the great Empire State was entered. It was with a thrill of joy and satisfaction that the terrible roads of Western Pennsylvania, which we had ploughed through for over a week, were a thing of the past. After leaving Cutterback, mountain climbing was renewed and continued to Otisville for four miles. This is one steady climb with many sharp and dangerous "S" and hairpin turns. The roads are rocky and very narrow.

At Newburg the Hudson river comes into view, and it is unquestionably the grandest river that will be seen by the contestants. It was our intention to cross the river from Newburg and continue through Poughkeepsie to Albany, but upon reaching Newburg we found the only way to cross the Hudson was by ferries, and, as this would necessitate a delay to the tourists, it was finally decided to continue on the west shore. A noticeable thing which was brought forcibly to our attention in New York State was the utter lack of signboards and a great quantity of forks and crossroads. In this respect Pennsylvania is far superior to the Empire State. Many hours were lost in New York State groping our way about on country roads, stopping the car, and inquiring the way from farmers and team drivers.

When Port Ewen was reached, 11-2 miles from Kingston, the ferry proposition again cropped up, which necessitated a detour of five to six miles into Kingston. The roads up to Kingston were in very good condition, but after leaving Kingston the roads were as bad, and in some places worse, than anything the big Premier had ploughed through. Water was running in rivers by the roadside, and the soft clay roads were nearly impassable. We were warned by farmers that the roads were in fearful condition, and one of them jokingly made the statement that he would bet his best team of horses against the Pathfinder that we could never reach Albany. Like the farmers of western Pennsylvania, those in this part of the country "repair" the roads by throwing the sod into the middle of the highway, leaving it there to be trampled down by the traveler.

In the vicinity of New Baltimore we were ditched for the first time. For two hours we worked at filling up the ditch with rocks, rails from the nearby fences, and boards borrowed from a farmhouse a half a mile away. For a time it looked as if nothing but horses could get us out of the quagmire. But by stubborn persistency driver McNamara landed the car at the top of the hill. Chains were of little use in the soft clay, and the rear wheels spun around inside the chains.

Between Kingston and Albany the Catskill mountains were continually in sight on one side, while the beautiful Hudson was on the other.

There are two predominating features of the eighth day run

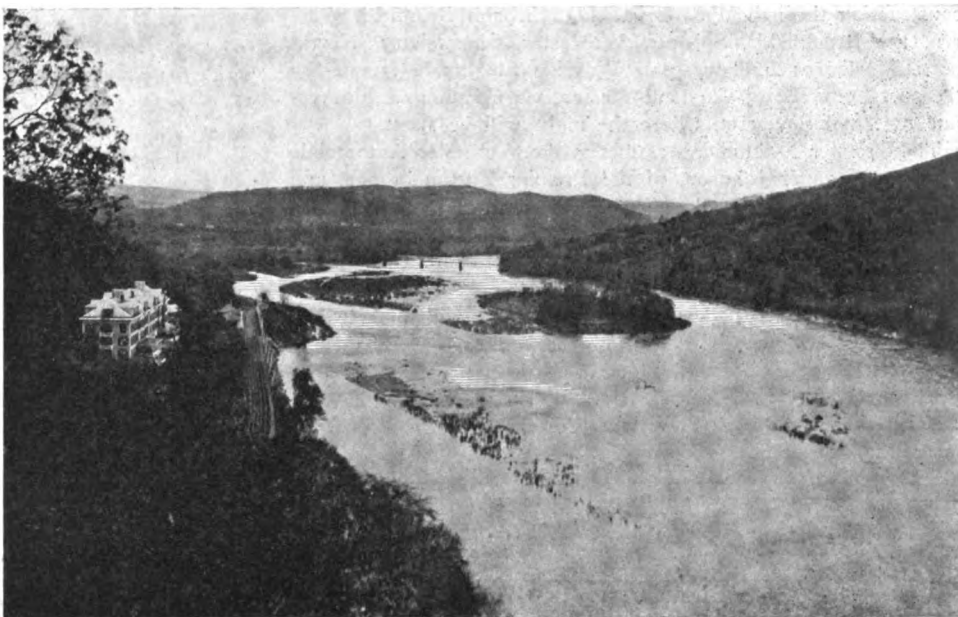

Where the Delaware River Forges its Famous Water Gap Through the Blue Mountains.

from Albany to Boston, a distance of 194.2 miles. Albany is left by driving over the drawbridge and into Rensselaer. The contestants are liable to be held up some time at this drawbridge, and the Premier Pathfinder had to wait about 20 minutes. For eight miles the route is over macadam roads and then over common dirt and clay roads. A direct line is taken to State Line, into Massachusetts. If for no other reason, the Pathfinders knew they were in Massachusetts because of its beautiful State highways. With the exception of a stretch of about five miles in the vicinity of Jacob's Ladder, the finest roads in the United States are gone over.

There are few tourists who do not know of the beauty of the Berkshire hills. There seems to be something totally different in the Berkshire scenery as compared with that of the Allegheny regions. The route from State Line to Boston is considerably different than that generally used by autoists. It leads through West Stockbridge, Stockbridge, East Lee, Chester, over Jacob's Ladder, Huntington, Fairfield, Westfield, West Springfield, across the Connecticut river into Springfield, Wilbraham, a detour of six miles to Three River (due to road



Near State Line, Which Marks the Boundaries of New York and Massachusetts.



construction through West Brimfield), through Brimfield, Warren, the Brookfields, Spencer, Worcester, Shrewsbury, Northboro, Marlboro; Sudbury, past Wayside Inn, made famous by the poet Longfellow; Wayland Weston, via Commonwealth Avenue to Hotel Somerset, where the night will be spent.

The Premier Pathfinder was met at the Worcester Automobile Club by Manager Johnson, of the Premier Boston branch, and J. C. Kerrison, of the Bay State Automobile Association. At Norumbega Park a delegation of three cars was lined up along the roadside awaiting the Pathfinder car. The four cars piloted us to the Hotel Somerset.

It is probable that the run from Boston will include the famous North Shore drive through Prides Crossing, Manchester, Magnolia, Gloucester, around Cape Ann and north to Portsmouth, N. H., Portland, Me. While the route will take the Pathfinders through New Hampshire and Vermont, with a probable finish at Saratoga Springs, New York, or Buffalo, it is not possible at this time to state what will be the exact route.

**BIG PRIZES FOR SPORT HILL CLIMBERS.**

BRIDGEPORT, CONN., May 18.—Preparations for the annual hill climb of the Automobile Club of Bridgeport, which will be held on Sport Hill May 30, are complete. The course will be guarded by soldiers, and the speed flights will be recorded by an electric timer. The value and importance of the prizes for the star events on the card promise to attract a noteworthy field of crack climbers. The Board of Trade cup, which has been dubbed "the local pride trophy," will be awarded to the winner of the free-for-all. The Robert B. Crauford cup will go to the successful owner, who must also be a pilot, in the amateur class. Henry D. Miller, vice-president of the Bridgeport Vehicle Company, builder of bodies, has also put up a trophy. It will be raced for in the class for cars listing over \$4,000.

An executive committee, made up of Ralph M. Sperry, Frank T. Staples, and F. W. Bolande will have charge of the climb.

**ALBANY CLUB TO HOLD HILL CLIMB.**

ALBANY, N. Y., May 18.—At the regular monthly meeting of the Albany Automobile Club, which was held at the clubhouse, 375 State street, last week, the conditions governing the 1908 sealed-bonnet contest for the McClure cup, as decided by the committee, were passed upon. All entries must be in by June 13, the fees being \$3 per car and \$1 per passenger. The route will be the same as that of the fourth annual tour of the club, and the running time each day will be from 9:30 A.M. to 5 P.M. John P. Randerson is chairman of the McClure cup committee, and the event is limited to members of the club.

The club will hold its first hill climbing contest May 23, on Menand's hill, the entry fee being fixed at \$2. Twelve events are scheduled, and a silver cup will be awarded to the winner in each. The classes include runabouts selling from \$1,250 or less, to \$2,500; free-for-all runabouts; touring car events for cars selling from \$850 or less, to \$3,000; six-cylinder cars; steam touring cars, and a free-for-all touring cars.

**TO HUNT JERSEY'S GRAFTING JUSTICES.**

NEWARK, N. J., May 19.—Believing that graft is at the bottom of not a little of the holding up and fining of automobilists by county constables and justices of the peace for alleged speed violations, the New Jersey Automobile and Motor Club will shortly begin a still hunt for the grafters. There is more than a mere impression prevailing that these rural minions of the law fail to make return of the full amount or all of the moneys paid over to them for fines and costs for alleged breakages of New Jersey's comprehensive laws. The inducement to make arrests and impose fines with such an object in view is manifest.

A. B. Le Massena, the club's secretary, has hit upon a clever means of tracing these defalcations. He is preparing cards to be sent to the members of his and other clubs, with the request that in case of an arrest and fine the cards be filled out, giving the full particulars of the case and especially the amount of the fines and the costs paid. The information will be confidential. At intervals Mr. Le Massena will go to Trenton and look over the records of the Department of Motor Vehicles comparing his reports of money paid with the amounts actually turned over to the State. Whenever there has been a withholding of the money, the club will wait for the expiration of the time limit, and then start criminal prosecution under the law making the withholding of the money a misdemeanor.

**TO STUDY WORKINGS OF BAY STATE LAW.**

CLEVELAND, May 18.—To illustrate the thoroughness with which the Ohio State Automobile Association is taking up the work in connection with the new motor vehicle bill, may be mentioned the fact that C. J. Forbes, Jr., secretary of the Cleveland Automobile Club; Secretary of State Carmi Thompson, and State Registrar of Automobiles Galey have left for Massachusetts to study the workings of that State's bill. The Ohio measure was modeled after this bill, and the local authorities figure that the best thing they can do is to study the actual working of this measure. In the neighborhood of a week will be spent in the East by the three men. It is also probable that Mr. Forbes will go on to New York to see officers of the A. A. A.

**LELAND'S STEARNS WRECKED AT SAVANNAH.**

SAVANNAH, GA., May 18.—The No. 7 Stearns car that Leland drove in the races here in March last went into a ditch at high speed on a part of the course not far from the city line last week, and Ross Geurard, who was at the wheel, as well as the three friends who were with him in the car, had a very narrow escape. No one was injured, outside of a miscellaneous collection of bruises which did not require a surgeon's attention, although a telephone message had quickly brought an ambulance, a corps of detectives and the chief of police to the scene.

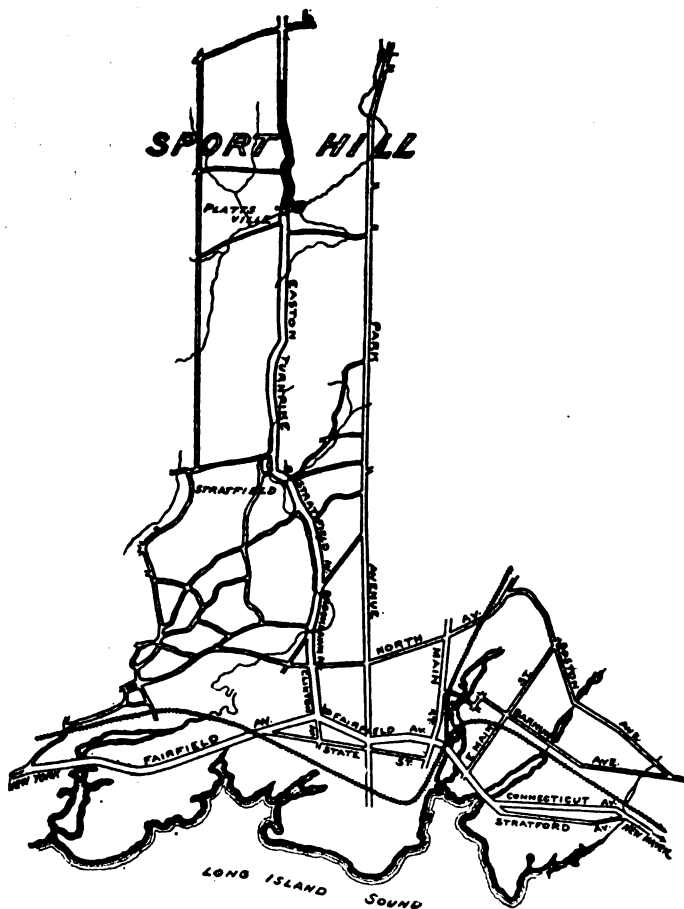

Sport Hill, Bridgeport, Conn., and Adjacent Roads.

## WHAT IS GOING ON AMONG THE CLUBS

### JOYCE OF MINNESOTA DESIGNS EMBLEM.

MINNEAPOLIS, MINN., May 18.—President Frank M. Joyce, of the Minnesota State Automobile Association, is responsible for the designing of an emblem that ultimately may be adopted by all the State associations of the A. A. A. The emblem combines the names of the National and State associations, and also the name of the city where the club is located. It is particularly fitted for use on the radiator, though it can be otherwise shown on the car if desired. The displaying of an emblem of this character by all the automobilists throughout the country unquestionably would call attention to the magnitude of the national body and the existence of State associations and local clubs. President Joyce was recently re-elected as the head of the Minnesota State Automobile Association, which is in a most flourishing condition and gaining rapidly in membership and influence.



### GRAND RAPIDS CLUB ALIVE AND PROGRESSIVE.

GRAND RAPIDS, MICH., May 14.—A few irresponsible automobile drivers are putting the Grand Rapids autoists in such ill repute that the club at its last meeting decided to try a new plan to stop reckless driving. Instead of leaving the matter entirely to the police, it was decided to appoint a "police" committee, consisting of three prominent men, to investigate the cases reported, and, if the evidence warrants, they will swear to the complaints personally.

Active preparations are being made by the club for the entertainment of the visitors at the State convention of the A. A. A., which is to be held here during the last week in May. A delegation from Grand Rapids will go to the Buffalo convention in July. The membership of the club at its last meeting was reported as 214, and a strong effort will be made to reach the 500 mark.

### LOWELL CLUB'S RACE TO BE 250 MILES.

BOSTON, May 18.—The Lowell Automobile Club has decided to lengthen its Fourth of July race from 200 to 250 miles. The following chairmen of committees have been appointed: Patrolling the course, Captain Gardner W. Pearson, company C, Sixth regiment, M.V.M.; publicity, Frank S. Corlew; finance, Humphrey O'Sullivan; course, Harry H. J. Read; transportation, Charles J. Wier; program, Burton J. Wiggin; hospital corps, Dr. J. A. Gage; options for racing camps, Jesse H. Shepard. Entries expected include Thomas, Apperson, Stearns, Renault, Panhard, Bianchi, Simplex and Lozier. The club will provide racing camps and otherwise take care of the racers. Alonzo G. Peck, of Boston, the veteran race starter, will be asked to officiate as starter.

### WILDWOOD IN JERSEY TO HAVE STRAIGHTAWAY.

WILDWOOD-BY-THE-SEA, N. J., May 18.—At the annual meeting of the Motor Club of Wildwood, held last Wednesday night, authority was given the contest committee to go ahead with preparations for the usual Fourth of July speed tournament on Central avenue boulevard. The annual election resulted in the choice of Philip P. Baker, president; Evans G. Slaughter, vice-president; V. G. Reynolds, secretary; J. Thompson Baker, treasurer; H. L. Hamersley, racing secretary; Thomas S. Goslin and John Bright, trustees.

### YORKERS OF PENN. ARE BUSY THESE DAYS.

YORK, PA., May 18.—The York County Automobile Association at its annual meeting decided to have an endurance run and races for members, and agreed to assist ten autoists, who were arrested for scorching, in their fight at court. It was the largest attended and most enthusiastic meeting ever held by the association, and every member was loud in his denunciation of Constable Doll, who has made himself conspicuous by prosecuting ten autoists for exceeding the speed limit on the famous Gettysburg turnpike leading to the Gettysburg battlefield.

Thirty-eight new members were elected, and there were fifty applications for membership received. John Kissinger, of this city, announced that the *Gazette* had offered a cup to the winner of an endurance run to be started from this city, and it was decided to have such a contest later in the summer. Stuart B. Lafean, son of Congressman D. F. Lafean, who has gained a reputation as a race driver, was made chairman of the committee on tours, races and contests. Thomas J. O'Neil, of Hanover, and Thomas Myers, of York, are the other members of the committee. The association decided to hold a tour to the Hanover Country Club at Waldheim on May 24.

### BROOKLYN TO CELEBRATE ORPHANS' DAY.

BROOKLYN, N. Y., May 20.—The Long Island Automobile Club's Orphans' Day committee has proved a hustling one. It has chosen Wednesday, June 10, for the annual auto outing for the children of Brooklyn's orphanages. Luna Park will again throw open its doors to the little ones. The Messrs. Feltman, who last year provided an excellent luncheon at cost, have generously offered this time to feed 800 children free. This was the number taken care of last year. The committee wishes this year to provide for 1,400, and has sent out return postal cards, asking that members authorize the treasurer to charge their accounts with \$2 each to feed the added 600. The committee is made up of Frank G. Webb, chairman; Charles C. Cluff, W. P. Richardson, Louis T. Weiss, and W. T. Wintringham.

### SCHENECTADY CLUB TO TOUR TO BUFFALO.

SCHENECTADY, N. Y., May 19.—Club tours are now occupying much of the attention of the Schenectady Automobile Club. At its last meeting it was decided to have a run to Buffalo in July to attend the Good Roads and Legislative Convention, and be present also at the start of the Glidden tour, whose participants will also be met by a club caravan at Saratoga. Arrangements for a run to Saratoga on May 31 were also made. Twenty members will make the trip.

### BALTIMORE PREPARING FOR ORPHANS' DAY.

BALTIMORE, May 18.—Arrangements are being made by the members of the Automobile Club of Maryland for the annual Orphans' Day automobile outing, June 10. C. Howard Millikin, chairman; Dr. H. M. Rowe and Frank W. Darling, the committee in charge of the outing, through E. A. Dolle, secretary of the club, have sent requests to 1,149 automobile owners in Baltimore and vicinity, asking them to loan their autos that day.

### TWIN CITIES IN OHIO ORGANIZE CLUB.

UHRICHSVILLE, O., May 19.—The Twin City Automobile Club was organized last week. It embraces Dennison and Uhrichsville, and starts with a charter membership of twenty-four, though a roll of fifty is expected within a very short time. The officers chosen were: President, C. L. Graves; first vice-president, C. O. Romig; second vice-president, A. R. Lanning; secretary-treasurer, Alexander Robinson.



Mrs. Teape and Daughter and Their Waltham Buckboard.

### FROM PORTLAND, ME., TO PORTLAND, ORE.

PORTLAND, Me., May 16.—On Tuesday, May 12, at noon, there saw started from Portland, the first trans-continental trip ever begun from the Forest City. The trip as planned will cover a distance of four thousand miles, and will take the whole Summer if necessary. Those who started on the long jaunt were Mrs. E. E. Teape and her daughter, Mrs. Vera McKelvie, of Sands Point, Idaho. The route of the autoists will end at Portland, Oregon, and will pass through the following cities: Boston, Springfield, Albany, Syracuse, Buffalo, Cleveland, Chicago, Des Moines, Cheyenne, Salt Lake City, Ogden, Boise and Baker City to Portland, the destination.

This trip was not the first the two have made, for last year they made a trip from Chicago to Denver. They are thoroughly acquainted with the West, and realize the difficulties which they will encounter. The journey is not in any sense a speed contest nor an endurance one. Mrs. Teape has driven a Waltham buckboard for several years, and in this make of car will make her trans-continental trip.

### NEW YORK TRADE'S CARNIVAL BANQUET.

Harmony, cooperation, and organization, as valuable factors of success in the retail automobile business, were appropriately dwelt upon by most of the speakers at the banquet given to newspaper men by the subscribers to the fund of the carnival promoted by the New York Automobile Trade Association. The function took place at the Brevoort Hotel last Saturday night. The social and fun-making feature of the affair was much more conspicuous than is usual at trade dinners. There were singing and jollity galore, and, altogether, the affair had the merry swing of a fraternity function. All this intimate commingling of the good fellows of New York's "automobile row" had its foundation in thus getting together for the promotion of the recent carnival.

A business meeting was made a part of the prandial gathering. Most important action was taken in the passage of resolutions declaring for another carnival next year, placing it under the management of the former committee of hustlers and again choosing for chairman Gen. John T. Cutting, whose offspring the spring opening celebration really was.

The report of the carnival committee showed that \$8,655 had been subscribed by 87 concerns, made up of 24 subscriptions of \$200 each, 21 of \$100, 18 of \$50, 23 of \$25, and 1 of \$10. To this was added \$870, received from entry fees to the hill-climb. The balance, \$347.45, was generously spent on the dinner.

Among the speakers were Gen. John T. Cutting, H. M. Duncan, O. J. Bechtel, J. C. Wetmore, L. H. Perlman, Harry Caldwell, Alfred Reeves, E. S. Partridge, Orrell A. Parker, Lawrence Hardy, A. G. Batchelder, Robert Lee Morrell, Alexander Howell, W. J. Morgan, Alex. Schwalbach, Peter Fogarty, Al. Camacho, and Senator Thomas H. Dunn, of Monroe County, N. J.

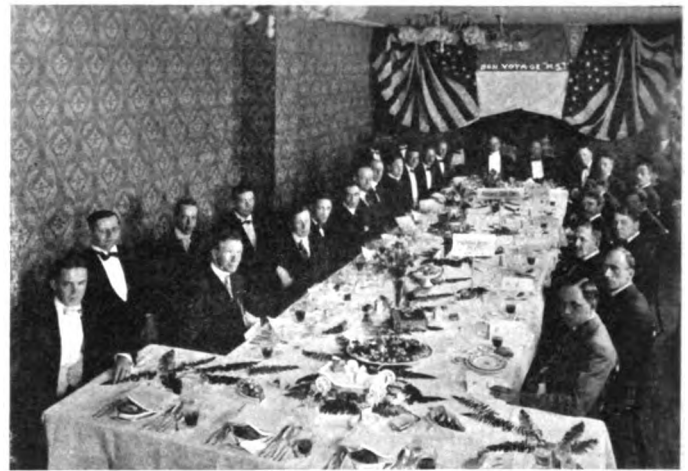

Where Guest of Honor Houpt and Friends Sat at Table.

### A BON VOYAGE BANQUET TO HARRY HOUP.

By way of bidding Harry S. Houpt bon voyage, and also wishing Louis Strang and John B. Marquise good luck in their quest for Grand Prix honors with the Thomas car, the selling staff of the Harry S. Houpt Company tendered the "easy boss" a banquet at the Hotel Marseilles, New York City, last Thursday evening. Mr. Houpt sailed on the *Lucania* yesterday, and on the same day the car and its full crew took passage by the *Adriatic*. All are to meet at the training quarters Mr. Houpt will engage on the Dieppe course.

Fred J. Titus, who acted as toastmaster, let no man escape. Every one had to get up and speak his little piece of tribute to the guest of honor, and good wishes for the success of the car and its crew. The pluck of E. R. Thomas in tackling the foreigners with a stock car, rather than to make good his entry was complimented, and the "live wire" part of Harry Houpt played in securing Strang for a driver, and his enthusiasm in agreeing to go over himself to manage the outfit, were justly and right royally extolled. The guest of honor responded with a modest expression of hope that the Thomas pilgrimage would not be in vain, coupled with confidence that the car ranked among the best of the American stock product.

"Le Gavroche Americain," as the French have already dubbed Strang, a title whose application will be understood by readers of Victor Hugo, in his speech, said he was sure he had a good car, and promised to do his best to land it near the front.

John E. Bowles and Henry G. Vogel, of the Harry S. Houpt Company, were made joint guests of honor, and made to respond to toasts. Mr. Bowles wanted everybody to forget that a Thomas car was going over, and bear in mind only that it was rather a case of an American car striving to uphold the honor of the United States against the foreigners. Edgar M. Houpt, who is ill, was given a cheer over the telephone. At one point the room was darkened, and "Bon Voyage, H. S.," blazed forth in electric letters.

Theodore Sheldon was the most active spirit in the arrangement of details of the successful banquet. His fellow hosts were Fred J. Titus, A. D. Frost, R. D. Willard, F. G. Youngs, F. K. Bowen, A. S. Robinson, F. D. Garringer, H. M. Pyke, and Montague Roberts.

### M'CORMICK'S OLDS WAS NOT THE CAR.

BALTIMORE, May 18.—In the report of the Maryland Sealed Bonnet contest, which appeared in *THE AUTOMOBILE* recently, it was stated that the Oldsmobile driven by A. L. McCormick stopped in the mountains and began to slide down a bad hill backwards, narrowly avoiding a collision with a Thomas car following. Investigation by the officials in charge of the event proved this to have been erroneous, a mistake having been made in the number of the car to which this happened.

**FRANKLIN SCORES IN DELAWARE ROADABILITY.**

WILMINGTON, DEL., May 16.—Frank L. Connable, who is connected with the DuPont Powder Company, and an enthusiastic autoist, enjoys the distinction of having won the first roadability run of the Delaware Automobile Association, which took place to-day over a 45-mile course, with the court-house as the starting and finishing point. The course led through Kennett Square and West Chester, Pa., partly over mud roads, for it had rained the day before, and partly over pike roads.

The committee having the arrangements in charge had fixed 3 hours 29 minutes as the time in which the run could be made; this liberal allowance being for the benefit of the low-powered cars, the run being open to all. Mr. Connable, who drove a Franklin touring car, made the exact time, and was awarded the handsome loving cup offered by the club as a prize. The next nearest was H. S. Lane, of Philadelphia, in a Thomas runabout, 3 hrs. 28 min.; and third was Robert S. Glover, of Wilmington, in a Maxwell touring car, 3 hrs. 34 min.

The fastest time was made by J. R. Richardson's Mitchell touring car, operated by Elmer Fisher, which covered the distance in 2 hrs. 27 min. Thirty-four were entered, and thirty-two started, all finishing except two, which met with mishaps.

**TEN PERFECT SCORES IN JERSEY RUN.**

PATERSON, N. J., May 18.—Of the even dozen cars that started in the 100-mile, non-stop, sealed-bonnet contest, held under the auspices of the North Jersey Automobile Club here last Friday, no less than ten of the contestants went round the full length of the course in the specified time of 5 hours 15 minutes.

The successful cars to finish were: G. A. Post's Winton, J. Hengeveld's Stevens-Duryea, J. Schofield's Corbin, G. DeWitt Brown's Maxwell, J. Vanderlock's Ford, H. B. Haines' Knox, the two Overlands driven by J. Garlick and Walter Hudson, and R. Beattie's Buick.

The start was made at 10 A. M., with three minutes' headway between the cars, and there was a large gathering to see the contestants off. The route led through Haledon, Pompton, Mountain View, Singac, and Little Falls, and included quite a few stiff hills. The two cars that fell by the wayside were S. Meredith's Corbin and R. W. Bates' Conover, but as the latter's delays were due to punctures, which cost him one hour and twenty minutes, he was not disqualified, time consumed in tire repairs being allowed, as is now the general custom in contests where endurance is the chief factor.

**NO DECISION IN SELDEN ROYALTY TANGLE.**

TRENTON, N. J., May 18.—Postponed from May 4 to to-day, the hearing of argument pro and con on the petition of the receivers of the defunct Electric Vehicle Company, of Hartford, Conn., for a modified form of contract between the latter concern and the Selden patent licenses, same before the United States Circuit Court here this morning. The court made it plain that consent would not be given to the adoption of the new contract unless at least three-fourths of the members of the Licensed Association would agree to it. Ex-Governor Griggs, who represented the interests of the latter, moved that a referee be appointed, ex-Chancellor McGill being mentioned in this connection, but the motion was denied, the court finally agreeing to take the matter under advisement.

**AERONAUT LAMBERT MAY REPLACE LAHM.**

PARIS, May 15.—A. B. Lambert, secretary of the Aero Club of St. Louis, has now made eleven balloon ascents from Paris, the last three having been alone, and has qualified for the pilot's license of the French club. It is very probable that Mr. Lambert will act as one of the American pilots in the Gordon-Bennett balloon race, taking the place of Lieutenant Lahm, whose position in the army makes his participation doubtful.

**RHODE ISLAND PASSES HORSEPOWER TAX BILL.**

PROVIDENCE, R. I., May 18.—After a two-hour discussion, in which a great number of amendments were proposed, and some of them adopted, the House of Representatives ended its second day of talking automobile legislation by passing the amended Senate measure. The act, as it came back from the judiciary committee of the House, contained many suggested amendments. Chief among those that were given serious consideration were the ones fixing the registration fee at 50 cents per horsepower per annum, and that raising the speed limit to 15 miles in closely built-up places, and to 25 miles in the country. These were passed. An attempt was made to make the latter limit 30 miles, but was defeated, as were also several other proposed amendments of doubtful importance. In spite of the fact that considerable competent testimony had been adduced at the hearing to show that a plain tire was apt to do more damage by skidding than one with a chain on it, an amendment was passed prohibiting the use of chains on gravel, macadam or other made roads, not including dirt roads or city pavements, except when there was at least one inch of ice or snow on the ground.

**STATUS OF THE LAMP DESIGN LITIGATION.**

It has been stated that in the various actions of the Rushmore Dynamo Works, Plainfield, N. J., against various makers and dealers who are alleged to have made and sold lamps in colorable imitation of the Rushmore designs, a preliminary injunction had already been granted. This was true in the case of the Manhattan Storage Company, which was recently convicted of violating the court order and was fined \$100. In the case of the complainant against the Badger Brass Manufacturing Company, of New York, which is the most important action in the litigation, the injunction order restraining the defendants has not been actually signed as yet, and will not be until the appeal of the Manhattan Screw and Stamping Works, from a similar restraining order granted against them, has been decided by the Circuit Court of Appeals.

The order of the United States Circuit Court for the Southern District of New York, signed by Judge Lacombe, is as follows:

The defendant having this day presented its petition for appeal to the United States Circuit Court, praying that an appeal might be allowed from the decree or order of preliminary injunction granted by said United States Circuit Court to the Circuit Court of Appeals for the Second Circuit and praying that said appeal might be made a supersedeas, and the Court having duly considered the matter, it is hereby ordered

First—That the appeal be allowed.

Second—That the exhibits be sent to the Circuit Court of Appeals as prayed for in the petition for appeal.

Third—That the order for preliminary injunction aforesaid shall not become effective immediately, but shall be suspended until two days after announcement of decision of Court of Appeals in Rushmore vs. Manhattan Screw and Stamping Works.



Three Tons of Indians on the Packard Truck.

During the stay of the Wild West Show in New York City the noble red men were given a ride on Riverside Drive. The photograph was taken in front of Grant's tomb.



## BRIEF ITEMS OF NEWS AND TRADE MISCELLANY

American sizes in Pirelli tires and tubes, with the regulation type American tire valves, may now be had of the various supply houses handling this Italian tire, or of the American branch office of Pirelli & Company, at 296 Broadway, New York.

Town cars of all sizes and types are rapidly being equipped with the Truffault-Hartford shock absorbers to prevent those uncomfortable jounces that result from the city's uneven pavements. Among the cars thus equipped during the past week were John D. Rockefeller's White steamer and Mrs. W. K. Vanderbilt, Jr.'s, Thomas town car.

The Warner Instrument Company, Beloit, Wis., makers of the Warner Auto-Meter, have just brought out an automatic tire-filling air-valve that is claimed to represent a revolutionary development in this field. It is opened by being brought into contact with the tire valve itself and is guaranteed to be positively self-closing. It is of extremely simple and durable construction and is claimed to be capable of filling a four-inch tire in 15 seconds, with 100 pounds pressure on the tank.

The annual meeting of the stockholders of the Monarch Motor Car Company, of Chicago Heights, Ill., was held at the Chicago Automobile Club, May 12. The old directorate, consisting of P. M. Hanney, Evan A. Evans, M. H. Kilgallen and T. A. Quinlan, Jr., was reelected, and R. J. Gunning, F. A. Moody and Rush C. Butler added to the board as new directors. T. A. Quinlan, Jr., was also reelected president and general manager of the company, and J. A. Ward, secretary and treasurer.

"Ready-Flated," the term first used in connection with the Continental tires on removable rims which were used in the recent Briarcliff race, is a registered trademark, and the Continental Caoutchouc Company is issuing a warning to the effect that the use of the name in connection with anything except the Continental product that it was coined to designate will be prosecuted. "Ready-Flated," says J. M. Gilbert, manager of the Continental company, "designates a Continental tire already inflated for use on a Continental rim. This is the type of tire replacement used on nearly half of the cars in the Briarcliff."

H. B. Wild, who has been making ascensions at the White City, Chicago, and other cities, has made arrangements with the Prest-O-Lite Company, Indianapolis, for a complete lighting and signaling outfit. The Prest-O-Lite storage tank to be supplied the aeronaut is made of aluminum, specially treated to give it high tensile strength, and has sufficient capacity to keep the searchlight burning for 20 hours. The lamp is also of aluminum and in addition to its use as a searchlight is fitted for "wig-wag" signaling, by means of shutters, and with red and green shutters for emergency signals. The total weight of the tank and searchlight is only 34 pounds.

It is not often that the vice-president of a republic cannot buy the car of his choice, yet this has been the case with Señor Ramon Corral, vice-president of Mexico, who ordered a 1908 Packard and was unable to secure one, in spite of the fact that the Packard company is turning out 300 more cars this year than last, all reports of financial depression and other alleged preventatives to the contrary notwithstanding. Señor Corral placed his or-

der with the Compañia Pan Americana de Vehiculos, Mexico City, but their wire arrived too late, every dealer having disposed of his allotment for 1908. It is an incident that forms striking evidence of the success the company has achieved in devoting itself to a single type of car. The entire Packard plant is now busy completing the output so that all the 1908 Packard 30's may be delivered on time.

A new method of construction designed to overcome a most frequent cause of trouble in pneumatic tires has been introduced by the Pennsylvania Rubber Company, Jeannette, Pa. This is the tendency of the tread to blister and separate from the carcass as the result of hard driving, and to overcome this fault mechanical power has been substituted for the usual method of hand wrapping, as it was found that the latter did not produce a uniform tension all round, and that there were apt to be numerous points where the union was imperfect. Another construction improvement is the use of fabric strips of sufficient length to go completely round the tire in place of the usual piecing together made necessary by the ordinary fabric. The new material is being woven especially for the manufacture of Pennsylvania tires, and the showing of the latter in the Briarcliff is said to be largely due to these improvements.

### NEW AGENCIES ESTABLISHED.

The Overland is a newcomer to Cleveland, O., where it will be handled by George Baumetz. Later on Mr. Baumetz will add the American and Marion cars to his agency line.

The Maxwell-Briscoe Motor Company has established an agency at Redlands, Cal., with S. F. Boynton & Sons. Rialto and San Bernardino are to be included in the territory covered by the new agency.

The Metropolitan Motor Car Company has just been appointed the Cleveland agent for the Knox Automobile Company, Springfield, Mass., and will handle the Knox line in that city and adjacent territory.

The Lowe-Crawford Company has just been organized in Boston by George H. Lowe and R. S. Crawford, to handle the Crawford car in that territory. Salesrooms have been opened at 173 Huntington avenue.

Way, Mitchell & Company is the title of a new firm organized to represent the Republic tire in Cleveland, O., and the agency establishment is soon to be opened on Euclid avenue opposite the Union Club. L. C. Pellott will act as manager.

Frank Coleman has been appointed agent for the Akron Pneumatic Tire Company, of Akron, O., at Cleveland, O., and will open headquarters at 1922 Euclid avenue. His territory includes the entire State of Ohio, with the exception of the cities of Akron and Cincinnati.

Hopewell Brothers, Cambridge, Mass., manufacturers of automobile fabric supplies and accessories, have withdrawn their agency from the Allen Auto Specialty Company, and have opened a New York branch house of their own. Quarters have been secured at 1900 Broadway, and C. A. Russell, formerly representing the firm in the New England territory, has been placed in charge.

The Regal Motor Car Company, of New York, has just been incorporated with \$50,000 paid up capital, to handle the product of the Regal Motor Car Company, of Detroit. A 25-horsepower, four-cylinder, sliding-gear car is being offered at \$1,250 in touring car and runabout types, and at \$1,800 in town car and taxicab styles. Walter C. Martin, for the past five years metropolitan agent for the Cadillac, will be manager of the new company. Headquarters have been selected in the new Rhinelander building at Sixty-eighth street and Broadway, and the salesrooms are attractively fitted up.

### RECENT TRADE REMOVALS.

S. E. Wherritt, sales manager of the Pierce Engine Company, Racine, Wis., who has his headquarters in Chicago, has removed from 1481 to 1507 Michigan avenue.

The Weldon & Bauer Company, successors to the F. E. Boland Company, Newark, N. J., representing the National line in that city, has removed to the new building at 200-202 Halsey street.

The Livingston & Ramsdell Company, agents for the Palmer & Singer cars in Newark, N. J., gave a housewarming on last Wednesday night to celebrate the opening of their new garage at 286 Halsey street.

It looks as if Halsey street would soon develop into the automobile "row" of Newark, N. J. The latest succession is the Linkroom Automobile Company, local agents for the Lozier cars, who have taken up new quarters at No. 239 recently.

### PERSONAL TRADE MENTION.

E. B. Gallaher, American manager of the Maja Company, Ltd., who has been abroad in the interests of the Maja car in this country, has sailed from the other side and is expected in New York next week.

T. W. Meachem, president of the New Process Raw Hide Company, Syracuse, N. Y., manufacturers of raw hide and metal pinions and gears, has just been elected president of the Chamber of Commerce of Syracuse.

Harry Fosdick, the genial junior member of the Hol-Tan Company, has seized upon the opportunity presented by a few days' let up in the business of getting Shawmut cars on from the factory at Stoneham, Mass., to take a three-day fishing trip to Lake Winnepesaukee.

Walter S. Austin, of the Austin Automobile Company, Grand Rapids, Mich., has been in the East recently looking round the agency situation and has returned to his home town, much pleased with the contracts he took back with him. It was not exactly an agency contract, but something in the matrimonial line, as he was married to Miss Elsie N. Chesebrough at Newton, Mass., May 12.

Alfred Reeves, general manager of the American Motor Car Manufacturers' Association, left early in the week, on his regular tour of inspection of the factories of members of the association, and incidentally to make some preliminary arrangements for the Chicago show, which will be managed by the makers themselves this year, the same plan being carried out in the case of the Grand Central Palace show in New York.

### INFORMATION FOR AUTO USERS

**Radio Batteries.**—This is a new accumulator, specially designed for automobile ignition service, which represents the result of more than ten years' experience in the manufacture of storage batteries. It is made by the Radio Battery Company, whose factory and repair shop are located at 433 West Forty-second street, New York City. The makers state that they have found the chief source of trouble in storage bat-



THREE-CELL SET, RADIO BATTERY.

teries to be the manner of constructing the plates and the lack of proper provision for retaining the electrolyte in the jars. To overcome these faults the containing jar of the Radio battery is of the flanged compartment type and is made from a new insulating compound that is acid proof. The cover is of the same material, made in one piece with the terminal bases and vent tubes, and is provided with a special ribbed edge. Pure para rubber washers hermetically seal the cells, while the gas ventilating caps screw into the vent tubes with a soft rubber washer. They are of the ball valve type. Cover clamps of enameled and noncorrosive steel are used and the handles are of the same material.

**Burrowes Emergency Wheel.**—E. T. Burrowes & Company, Portland, Me., have recently placed on the market an improved type of spare wheel which presents several new features. It is made to take the different sizes of tires in use

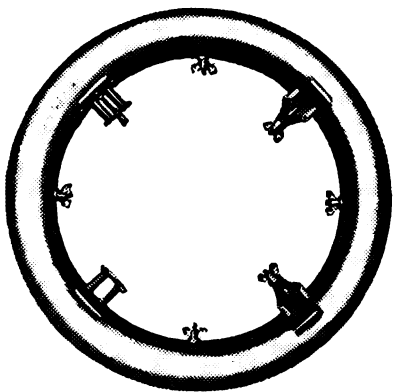

CONSTRUCTION OF BURROWES SPARE WHEEL.

and will be supplied for either clincher or quick detachable types. Where the front and rear are different sizes, special spare wheels to fit either will be furnished. To attach the new Burrowes spare wheel it is only necessary to hook one of the rigid clamps, or anchor posts, over the rim of the car wheel where it

rests on the ground, and then roll the car on the clamp. Next the other rigid clamp is hooked over the rim and the two screw clamps are tightened until the wheel is held firmly in place. As a precaution against creeping, straps are passed round two of the clamps and the adjacent spokes. These straps may be attached to either the anchor posts or the adjustable screw clamps in such a way that they cannot fall off, even when loose. The valve stem is protected by the anchor post on the rim. The Burrowes spare wheel is very rigid and does not affect the running or steering of the car. The rims are inspected and approved by the Association of Automobile Tire Manufacturers.

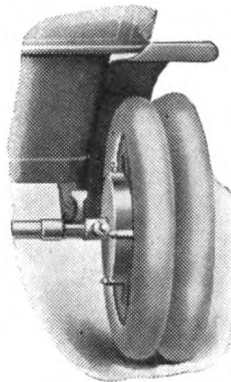

BURROWES WHEEL ON CAR.

**Winship Auto Trunks.**—The name of Winship has been associated with high-grade trunks and other travelers' requisites for more than half a century past, W. Winship, 71 Summer street, Boston, Mass., having made an enviable reputation for quality in this line. In catering to the wants of the autoist he has brought out a very extensive range of trunks to fit all kinds of cars and on all



TYPES OF WINSHIP AUTO TRUNKS.

kinds of places on the car, in addition to an assortment of touring equipment of other kinds, such as special pockets of genuine or imitation leather to fasten on the back of the forward seats, imported lunch baskets in great variety, lunch trunks, emergency kits, ice trunks and ice baskets, buffet trunks and the like.

**"Buckeye" Cleanser.**—"No one who has ever used Buckeye Cleanser has ever accused it of being like the ordinary kind," say the makers, the J. P. Davies Company, Dayton, O., manufacturers of laundry and textile soaps and successors to the Buckeye Soap Company. It is a soap made entirely of pure vegetable oils and is prepared especially for cleansing highly polished and painted surfaces. Being perfectly free from alkali or gritty substances, it does not scratch or leave the cleaned surfaces with a smoky appearance, but produces a bright shine on a polished surface like

a new coat of varnish. It is put up in five and ten-pound cans, twenty-five-pound pails and barrels or half barrels. Samples will be forwarded on request.

**Patterson Wireless Battery Holder.**—A new and decidedly radical improvement in the manner of connecting up dry cells is embodied in an invention which is just being placed on the market by Stanley & Patterson, 23 Murray-27 Warren streets, New York. In fact, it is such a simple, logical and sensible way of connecting up a battery of dry cells that the wonder is no one thought of it before, for binding posts and connecting wires have certainly furnished their quota of ignition troubles to the autoist. The new device consists of a base holding several sockets into which the several cells comprising the battery are intended to be screwed home until they make contact with the "automatic bridge"—a patented form of connection which closes the circuit between the two adjoining cells automatically the moment a cell is removed from one of the receptacles. Thus a dead cell may be re-



PATTERSON WIRELESS BATTERY HOLDER IN CASE.

moved at any time without interrupting the ignition current, and if a new cell be not available at the moment no change in the connections is necessary. When the new cell is procured it is simply screwed into place. This permits of taking out any cell that happens to be exhausted, without disturbing the rest and with a minimum of trouble.

The Patterson "Wireless" battery holders are made to accommodate 6, 8, 10, 12 and 16 cells of battery, but any



WIRELESS CELL SOCKETS.

combination of cells is made possible by means of the "automatic bridge." The Patterson type dry cells intended to be used with these holders do not differ from the standard dry cells, except that at the top the zinc containing case has a deep thread rolled into it, while the carbon has a flat butt terminal. The complete holder is enclosed in a waterproof cabinet and the latter is provided with a false bottom, so that in case the Patterson cells are not procurable on a long tour this can be lifted out and the usual type employed. The company will forward its Bulletin "C," describing the different models, on request.



**INDEX  
TO ADVERTISERS**

Abrams-Mason Co. ....	82	Crown Soap Co. ....	70	Kent Mfg. Works, A. ....	98	Pittsfield Spark Coil Co. ....	72
Acetylene Gas Illuminating Co. ....	58	Cullman Wheel Co. ....	57	Keystone Lubricating Co. ....	78	Premier Motor Mfg. Co. ....	103
Acme Motor Car Co. ....	62	De Luxe Motor Car Co. ....	62	Kimball Tire Case Co. ....	68	Prest-O-Lite Co. ....	105
Adams Co. ....	62	Detroit & Buffalo Steamboat Co. ....	60	King Top Mfg. Co. ....	61	Progressive Mfg. Co. ....	76
Aerocar Motor Co. ....	62	Diamond Chain & Mfg. Co. ....	58	Kinsey Mfg. Co. ....	61	Quinby Co., J. M. ....	61
Ajax-Grieb Rubber Co. ....	56	Diamond Rubber Co. ....	59	Kissel Motor Car Co. ....	104	Radio Battery Co. ....	96
Almy Water Tube Boiler Co. ....	57	Dien, Ch. ....	88	Konigsloew, Otto ....	59	Raines & Co. ....	57
American Ball Bearing Co. ....	78	Dietz Co., R. E. ....	73	K.W. Ignition Co. ....	92	Rainier Motor Car Co. ....	63
Am. Brass & Alum. Works. ....	59	Dixon Crucible Co., Joseph. ....	85	Lavalette & Co. ....	57	Rajah Auto Supply Co. ....	64
American Bronze Co. ....	79	Dorris Motor Car Co. ....	65	Lavnigne Mfg. Co. ....	58	Randall-Falchney Co. ....	78
Amer. Motor Car Sales Co. ....	105	Duff Mfg. Co. ....	59	Lear Automobile Co., Oscar. ....	63	Reading Automobile Co. ....	58
American Motor Truck Co. ....	88	Duplex Coll. Co. ....	64	Leather Tire Goods Co. ....	62	Reeves Pulley Co. ....	59
Anderson Forge & Machine Co. ....	59	Duplex Co. ....	69	Limousine Carriage Mfg. Co. ....	57	Regent Leather Tire Co. ....	86
Apperson Bros. Automobile Co. ....	103	Earl Motor Car Co. ....	62	Lipman Mfg. Co. ....	61	Remy Electric Co. ....	53
Appliance Mfg. Co. ....	70	Echo Horn Co. ....	83	Lobee Pump Co. ....	58	Renault Frères ....	Cover
Ashtabula Bow Socket Co. ....	61	Eclipse Machine Co. ....	59	Locke & Co. ....	58	Republic Rubber Co. ....	90
Ashton Valve Co. ....	58	Eco Mfg. Co. ....	89	Lockwood Bros. ....	59	Rex Wrench Co. ....	76
Atlas Motor Car Co. ....	62	Edmunds & Jones Mfg. Co. ....	58	Locomobile Co. ....	62	Richardson Engineering Co. ....	59
Audel & Co. ....	72	Eldredge Electric Mfg. Co. ....	57	Logan Construction Co. ....	62	Robert Instrument Co. ....	57
Aurora Motor Works. ....	62	Electro Importing Co. ....	60	London Auto Supply Co. ....	61	Royal Equipment Co. ....	58-83
Austin Automobile Co. ....	Cover	Elite Mfg. Co. ....	77	Long Arm System Co. ....	83	Rushmore Wheel Works. ....	100
Auto Car Equipment Co. ....	87	Ellsworth, J. M. ....	108	Long Mfg. Co. ....	67	Salisbury Dymal Mfg. Co. ....	59
Auto Pump Co. ....	67	Elmore Mfg. Co. ....	95	Long & Mann Co. ....	58	Samson Leather Tire Co. ....	63
Auto Time Saver Co. ....	58	Empire Automobile Tire Co. ....	84	McCord & Co. ....	69	Selden Motor Vehicle Co. ....	69
Autocar Co. ....	103	Empire State Tire Co. ....	83	Macbeth Evans Glass Co. ....	89	Shaler Co., C. A. ....	83
Automobile Blue Book. ....	66	Excelsior Supply Co. ....	70	Manhattan Storage Co. ....	57	Shawver Co. ....	67
Automobile Supply Co. ....	64	Factory Sales Corporation. ....	89	Marvel Mfg. Co. ....	85	Slama Tire Protector Co. ....	70
Auto-Shine Co. ....	57	Firestone Tire & Rubber Co. ....	63	Mason Motor Car Co. ....	88	Smith Co., A. O. ....	93
Avery Portable Lighting Co. ....	67	Fisk Rubber Co. ....	82	Masury & Son, John W. ....	89	Smith Mfg. Co., R. H. ....	65
Baker Motor Vehicle Co. ....	55	Flentje, Ernst ....	83	Matheson Motor Car Co. ....	95	Spacke Machine Co. ....	78
Baldwin Chain & Mfg. Co. ....	58	Forest City Motor Car Co. ....	97	Maxwell Briscoe Motor Co. ....	109	Spare Motor Wheel of Am. ....	92
Banker Bros. Co. ....	77	Franklin Mfg. Co., H. H. ....	107	Mayo Radiator Co. ....	58	Speed Changing Pulley Co. ....	76
Barnett Drop Forging Co. ....	55	French Mfg. Co. ....	64	Mechanical & Elec. Mfg. Co. ....	64	Speedwell Motor Car Co. ....	63
Bartholomew Co. ....	38	G & J Tire Co. ....	71	Merchant & Evans Co. ....	83	Spicer Universal Joint Mfg. Co. ....	59
Beaver Mfg. Co. ....	93	Garford Motor Car Co. ....	62	Merritt & Co. ....	59	Splitdorf, C. F. ....	77
Behen-Faught Motor Car Eq. Co. ....	64	Gearless Transmission Co. ....	86	Mezger, C. A. ....	92	Sprague Umbrella Co. ....	80
Bellfuss Motor Co. ....	81	Geiszler Bros. ....	87	Michelin Tire Co. ....	63	Standard Automatic Lub. Co. ....	58
Beloit Supply Co. ....	59	Gemmer Mfg. Co. ....	79	Midland Motor Car Co. ....	102	Standard Co. ....	94
Black Mfg. Co. ....	88	General Accumulator and Battery Co. ....	63	Miller Bros. ....	61	Standard Connecting Rod Co. ....	65
Blasler Mfg. Co., M. E. ....	61	Gibney & Bros., Jas. L. ....	58	Miller, Chas. E. ....	85	Standard Welding Co. ....	79
Boston Auto Gage Co. ....	57	Goldberg Motor Car Devices Mfg. Co. ....	74-75	Miller & Starr. ....	59	Stanley & Patterson. ....	99
Bowser & Co., S. F. ....	59	Gray & Davis. ....	Cover	Mitchell Motor Car Co. ....	62	Star Speedometer Co. ....	94
Boyle & Co., John. ....	96	Grout Auto Co. ....	82	Model Automobile Co. ....	101	Steam Carriage Boiler Co. ....	58
Brennan Motor Mfg. Co. ....	85	Ham Mfg. Co., C. T. ....	81	Moline Automobile Co. ....	101	Stearns Co., F. B. ....	63
Brown Co. ....	77	Hans, Edmund E. ....	82	Moon Motor Car Co. ....	86	Stevens-Duryea Co. ....	102
Brownell Motor Co., F. A. ....	57	Hardy Co., The R. E. ....	64	Mora Motor Car Co. ....	Cover	Studebaker Automobile Co. ....	67
Buckeye Jack Mfg. Co. ....	65	Harris Oil Co., A. W. ....	71	Morgan & Wright. ....	63	Success Auto Buggy Co. ....	63
Buckeye Mfg. Co. ....	62	Hartford Suspension Co. ....	64	Mosler & Co., A. R. ....	77	Supplementary Spiral Spring. ....	69
Buffalo Carburetor Co. ....	81	Hatcher Auto Parts Co. ....	77	Moss Photo Engraving Co. ....	92	Swinehart Clincher Tire Co. ....	77
Buob & Scheu. ....	61	Haynes Automobile Co. ....	87	Motor Car Co. ....	88	Syracuse Alum. & Bronze Co. ....	90
Burlington Basket Co. ....	64	Healy Leather Tire Co. ....	63	Motor Car Specialty Co. ....	78	Thomas Motor Co., E. R. ....	84
Byrne-Kingston Co. ....	93	Hedgeland Mfg. Co. ....	104	Motz Clincher Tire & Rub. Co. ....	63	Thompson Sons Co., J. P. ....	61
Cadillac Motor Car Co. ....	62	Heinze Electric Co. ....	70	Mound Tool & Scraper Co. ....	82	Timken Roller Bearing Axle Co. ....	98
Cameron Car Co. ....	Cover	Heltger Carburetor Co. ....	57	Multiple Ignition Co. ....	91	Tincher Motor Car Co. ....	87
Canton Drop Forge & Mfg. Co. ....	59	Hercules Electric Co. ....	73	Mutty Co., L. J. ....	61	Torbenson Motor Co. ....	78
Capitol Auto Co. ....	61	Herz & Co. ....	91	National Auto Accessories Co. ....	57	Tray Plate Battery Co. ....	81
Chadwick Engineering Works. ....	62	Hess-Bright Co. ....	59	National Motor Vehicle Co. ....	97	Trebert Gas Engine Co. ....	63
Champion Co., A. ....	79	Hicks Speed Indicator Co. ....	77	Neustadt Auto & Supply Co. ....	90	Trojan-Hydro P n e u m a t i c Wheel Co. ....	84
Chandlee & Chandlee. ....	65	Hoffecker Co. ....	64	Never-Miss Spark Plug Co. ....	58	Tucker, C. F. ....	57
Chase-Shawmutt Co. ....	55	Hoffman, Geo. W. ....	57	New England Motor Co. ....	82	Uncas Specialty Co. ....	71
Chicago Auto Top Co. ....	55	Holley Bros. Co. ....	67	Nichols & Co., D. P. ....	61	Underwood Typewriter Co. ....	90
Chicago & Alton Ry. ....	72	Holsman Automobile Co. ....	58	Nordyke & Marmon Co. ....	62	U. S. Fastener Co. ....	79
Clark, E. S. ....	57	Hotel Densmore. ....	60	Northway Motor & Mfg. Co. ....	58	Veeder Mfg. Co. ....	94
Cleanola Co. ....	64	Hotel Douglas Manor Inn. ....	81	Nuttall Co., R. D. ....	59	Vehicle Specialty Co. ....	68
Cleveland Canton Spring Co. ....	83	Hotel Joyce. ....	60	N. Y. Gear Works. ....	64	Walker Bros. Co. ....	61
Cleveland Motor Car Co. ....	76	Hotel Monmouth Beach. ....	81	N. Y. Sporting Goods Co. ....	71	Warner Instrument Co. ....	97
Cleveland Spark Plug Co. ....	100	Hotel New Cliffs. ....	60	N. Y. & N. J. Lubricant Co. ....	91	Watt-Detroit Carburetor Co. ....	85
Colgan Co., J. W. ....	52	Hotel Pontchartrain. ....	81	Oakes & Dow Co. ....	73	Wayne Automobile Co. ....	63
Columbia Lubricants Co. ....	81	Hotel Rexford. ....	60	Oefeldt & Sons. ....	64	Welch Chain Tire Grip Co. ....	67
Comptoir d'Innovations pour Automobiles. ....	58	Hotel Westminster. ....	60	Olds Motor Works. ....	62	Welch Motor Car Co. ....	84
Conn. Tel. & Elec. Co. ....	68	Howard Motor Works. ....	62	Owen & Co., R. M. ....	63	Western Motor Co. ....	84
Continental Caoutchouc Co. ....	63	Hoyt Electrical Ins. Co. ....	93	Pacific Tucking & Mfg. Co. ....	57	Weston Elec. Instrument Co. ....	86
Continental Motor Mfg. Co. ....	67	Hume Carriage Co. ....	61	Packard Electric Co. ....	58	Wheeler & Schebler. ....	106
Corbin Motor Vehicle Corp. ....	83	Imperial Motor Car Co. ....	59	Packard Motor Car Co. ....	110	White Co. ....	Cover
Cornish-Friedburg Motor Car. ....	62	Indestructible Steel Wheel Co. ....	52	Palmer & Singer Mfg. Co. ....	62	Whitney Mfg. Co. ....	79
Correspondence School of Motor Car Practice. ....	64	Jackson Automobile Co. ....	62	Parish & Bingham. ....	59	Windsor Mfg. Co. ....	79
Cotta, Chas. ....	59	Jeffery & Co., Thos. B. ....	111	Parker Mfg. Co. ....	78	Winship, W. W. ....	80
Cowles & Co., C. ....	57	Jeffery-DeWitt Co. ....	57	Parker, Stearns & Co. ....	78	Winton Motor Carriage Co. ....	112
		Jenckel Motor Mfg. Co. ....	69	Pennsylvania Rubber Co. ....	55	Wisconsin Tire Protector Co. ....	82
		Jones Speedometer. ....	61	Peugeot Frères. ....	61	Witherbee Igniter Co. ....	57
		Jones, Wm. H. ....	57	Pfanstiehl Elec. Laboratory. ....	72	Wyman & Gordon Co. ....	55
		Joyce Criland Co. ....	81	Picrome Hide Co. ....	59	York Motor Car Co. ....	87
		Kellom Co., Chas. F. ....	65	Pierce Engine Co. ....	62	Zimmerman Mfg. Co. ....	84
				Pike Mfg. Co. ....	79		
				Pioneer Brass Works. ....	59		
				Pirelli & Co. ....	63		

**MONOGRAMS AND NAME PLATES**

WRITE FOR OUR LATEST CATALOG

**J. W. COLGAN CO.**

SUBBURY BUILDING — BOSTON, MASS.

ALL STYLES ALL SIZES

# THE AUTOMOBILE

## One Man's Family Tour from Coast to Coast

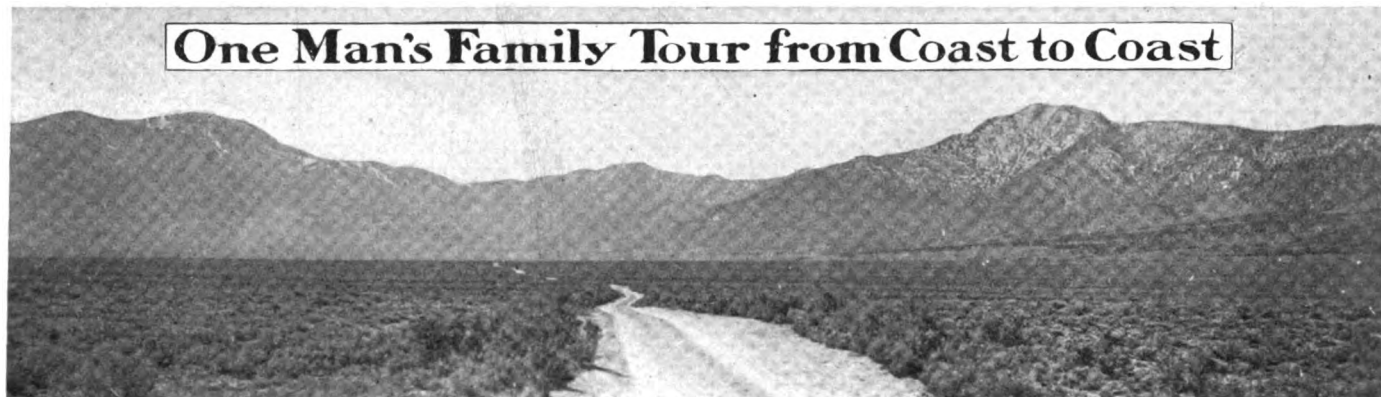

JACOB M. MURDOCK, of Johnstown, Pa., ended at New York at 2:07 o'clock on Tuesday afternoon a Pacific-to-Atlantic run of 3,674 miles, having covered in a Packard car the distance in 25 1-2 days of actual running, or, to be exact, in 32 days 5 hours 25 minutes gross between the times of start and finish. Mr. Murdock thereby set up new Pacific-to-Atlantic figures for a car operated by a single crew, though not, of course, equalling the record of 15 days 2 hours 10 minutes accomplished by the Franklin six-cylinder with shifts of drivers.

These figures, however, convey most inadequately the value of the present performance, which can truly be said, all circumstances and conditions considered, to have been the most remarkable and convincing demonstration of the touring practicability of the automobile that has yet been given.

### The Owner Drove Entire Distance.

Mr. Murdock, an out-and-out amateur owner, drove the entire distance himself. He carried in his car a full complement of seven passengers, comprising his wife, three children, a guest and a mechanic. He drove solely by day and rested on the five Sundays of the journey and lay over two days besides, one on account of rain and the other for recreation at his own residential town. In a word, Mr. Murdock's was an out-and-out touring run and in no sense a race for record.

His average mileage per running day was 146.36 miles. His longest day's run was 244 miles, between Pittsburg and Philadelphia, and his best Western mileage 241 miles, between Cheyenne and North Platte, which was followed by a 235-mile run the following day to Columbus, Nev. The total weight of the Packard, including equipment, fuel and passengers, carried as far as Ogden, was 500 pounds, barring a 150-pound lessening of weight through Nevada.

The performance of the car itself was, of course, equally as noteworthy as was the driving of its pilot. A broken ball bearing in the front wheel caused three hours' delay and a burnt connecting rod bearing through the oil running low cost five hours. That was all the mechanical stoppages. The Continental tires performed as well as did the engine. On reaching New York the car was running on its second set, and but two punctures had been sustained during the entire journey.

Mr. Murdock proved a transcontinental automobile tour to

be pleurably possible and took a journey across the continent out of the category of abnormal stunts. He demonstrated that no path on this continent presents difficulties not surmountable by the pluck and patience of a tourist.

Mr. Murdock's passenger list was made up of Mrs. Murdock, their daughters Lillian and Alice, age sixteen and fourteen respectively, and their son, Jacob, Jr., a youngster of but eight years, and his mechanic, Philip de May. L. L. Whitman was a guest as far as Ogden, and P. W. Spaulding, a lawyer of Evanston, Wyo., from that point to the end of the journey.

Mr. Murdock himself, a man in the "forties," though looking to be far down in the "thirties," is a lumber merchant of the firm of J. M. Murdock & Bros., Johnstown, Pa. He spends his winters at Pasadena, Cal. He told his story most modestly at the Bellevue-Stratford on Monday night to a contingent of newspaper men M. J. Budlong, president of the Packard Motor Car Company of New York, had taken over to Philadelphia that afternoon in three cars to hear it. This trio of cars escorted Mr. Murdock to New York the following day.

### How He Got Transcontinental Idea.

"I had occasion to make several trips between Johnstown and Pasadena this winter," said Mr. Murdock, by way of starting his story. "I spent many hours looking out of the car windows and dreaming dreams of making the journey home some day in my automobile. You see, I had been reading in the trade papers with great interest the tale of the Pekin-to-Paris run and the stories of the present New York-to-Paris race. When I reached Pasadena in February I had no idea of attempting the journey, and had even gone so far as to buy my railroad tickets home. I would keep asking myself: 'Is there a road across the United States?' My answer would always be 'yes.' Then I got to talking with L. L. Whitman, who lives in Pasadena, of how I could find it and of the possibilities of making the journey with my family. Finally I determined to make the attempt; at least, I resolved to go to that point when the discomforts should exceed the pleasures, and then to stop. That point, you see, was never reached.

"I made, two weeks before I started, a trip of 150 miles into the Mojave desert, the place I most, and almost only, feared. Then I came back and persuaded Mr. Whitman to accompany



me as far as Ogden. I did not wish to lose my family in the desert. I knew I would feel safe in staying by them if he were along to go for help if needed.

"We started from Los Angeles at 8 o'clock in the morning on April 24. I had waited to join in the welcome to Admiral Evans' fleet. We carried five days' provisions for emergency in crossing the Nevada desert, and water, too. There are water stations every fifty miles. Some in the center is not fit to drink. The natives will tell you which are good and which bad. I met at their hands, by the way, the kindest treatment throughout my journey. There are practically no maps of the desert. The latest United States survey maps show a blank space in the Death Valley district. Many of the places marked were practically no settlements at all, or the mere tumbledown shacks of deserted mining camps.

**Good Roads to Goldfield and Tonopah.**

"We headed for Daggett, and then northeast, crossing Death Valley, and came to Beatty. Between this place and both Goldfield and Tonopah, there are two roads, one for automobiles and the other for wagons. Cars built for Eastern use are at a great disadvantage in this district. They have too low clearance for the rocks and deep ruts, nor are they wide enough to fit the ruts. These rocks and ruts gave us great trouble. They would catch the flywheel and we were in constant fear of ripping it off. I had to stop at least ten times a day to pry the pan away from the flywheel. This question of clearance was, in fact, the most difficult of our problems in this region.

"The country abounded in dry lakes, some five to seven miles across, with a spongy surface that took a bit of nerve to tackle.



Then there was a driftsand that filled the tracks like quicksilver. At times we would have to wrap the wheels with heavy rope and replace it every half hour. Though we carried 150 feet, it was exhausted at Goldfield.

"Leaving Tonopah, we set out northeast for Ely, a journey of 240 miles, these points being railroad connections, so we were reasonably near enough to a railroad for safety. The road was remarkably good, there being lots of long stretches admitting of 25 to 30 miles an hour going. Our only guides were rough pencil drawings and the United States maps. We steered by compass a lot. In fact, we reached Ogden, having strayed no further than five miles from the true course.

**Road Was a Nightmare.**

"The road from Ely to Cobre, Nev., has not a grade or a hill and few 'washes.' For 140 miles it is good for 75 miles an hour. We had planned to make the run from Cobre to Ogden, 150 miles, in one day. It took us two days of the hardest work: From

Cobre to Kelton it is a nightmare. You have to straddle ruts a man could almost stand in. It is 80 miles to Kelton and 70 miles to Ogden, the latter a veritable swamp with mud two feet and water four feet deep in places. We took to the railroad track and bumped the ties for five miles. Further along we encountered twenty-five to thirty hills that would stop the wheels and stall the motor. We would have to throw on power and then block the wheels behind and repeat the operation. On one occasion we were from 2 to 6 o'clock in thus climbing a 300-foot stretch.

**Advices Traveling Eastward.**

"If you contemplate a transcontinental trip, by all means go West and come East, for the prevailing winds are from West to East, and they can keep or retard one a lot.

"I carried a speedometer, a glass front and a cape top. I only had to replace two springs. I did not reinforce anything before I started and did not even have the engine gone over. In addition to 22 gallons in the tank, I carried 5, 10 and 15-gallon cans of gasoline on the running board. My touring equipment embraced 250 feet of rope of assorted sizes, two shovels, pick, axe, sledge hammer and wrench. We used our cooking outfit quite often, as we slept not a little in unfinished shacks.

"We struck snow in Wyoming, being caught in quite a blizzard

Mr. Bennett, the Packard's Pittsburgh representative, left the Hotel Bellevue-Stratford Tuesday at 8:45 A.M., and started for New York from the Camden side at 9 o'clock. An easy run with stops at Trenton, New Brunswick and Newark brought the outfit to Weehawken ferry and landed it at the Packard Motor Car Company's garage, at Broadway and Sixty-first street, at 2:07 P.M. Mr. Murdock's odometer showed 3,693.3 miles at the finish. The excess over the aggregate of the daily runs taken from his notebook and herewith printed probably represents use of the car at his home at Johnstown and other places, as the route was not always strictly adhered to.

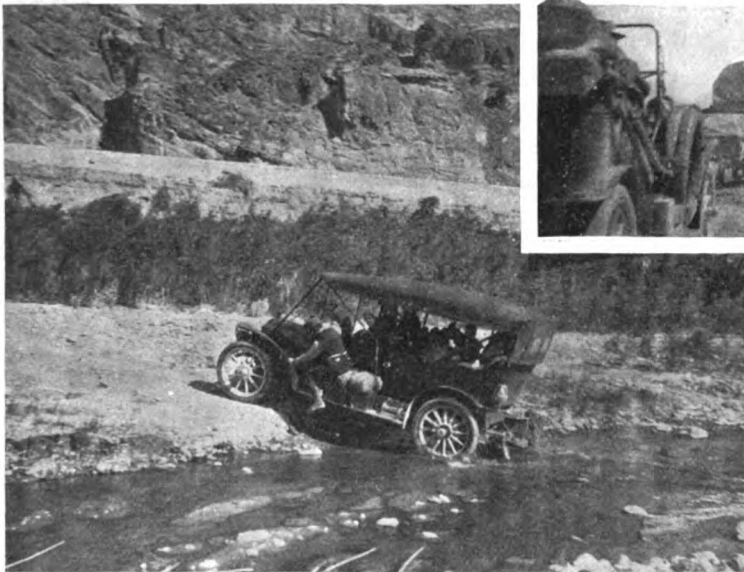

**The Murdock Itinerary.**

Date.	Terminus.	Miles.
April 24.....	Start Los Angeles.....	0
April 24.....	Garlick Lake, Cal.....	173
April 25.....	Resting Springs, Cal.....	67
April 26.....	Sunday.....	0
April 27.....	Goldfield, Nev.....	174
April 28.....	Stony Cabin, Nev.....	84
April 29.....	Ely, Nev.....	155
April 30.....	Montello, Nev.....	167
May 1.....	Kelton, Nev.....	84
May 2.....	Ogden, Utah.....	96
May 3.....	Sunday.....	0
May 4.....	Evanston, Wyo.....	85
May 5.....	Stopped by rain.....	0
May 6.....	Granger, Wyo, via Oakley.....	103
May 7.....	Wamsutter, Wyo.....	135
May 8.....	Rock River, Wyo.....	135
May 9.....	Cheyenne, Wyo.....	114
May 10.....	Sunday.....	0
May 11.....	North Platte, Neb.....	241
May 12.....	Columbus, Neb.....	235
May 13.....	Dennison, Ia.....	172
May 14.....	State Center, Ia.....	134
May 15.....	Clinton, Ia.....	191
May 16.....	Chicago, Ill.....	141
May 17.....	Sunday.....	0
May 18.....	Goshen, Ind.....	143
May 19.....	Toledo, O.....	150
May 20.....	Warren, O.....	190
May 21.....	Pulsbey, O.....	78
May 22.....	Johnstown, Pa.....	79
May 23.....	Rest.....	0
May 24.....	Sunday.....	0
May 25.....	Philadelphia.....	244
May 26.....	New York.....	104
Total.....		3,674

in the Laramie plain. We had little rain, most of it being ahead of us and leaving us its mud. We did not have to make a change in the carbureter for any elevation from sea level to 9,000 feet. The engine did not miss except during the snowstorm on the Laramie plain. The mud of Iowa was unspeakable, and, in fact, was the only serious obstacle east of Cheyenne.

"Before I had started, I had calculated on an average of 100 miles a day. Before I finished I found that steady going would give a much bigger mileage than this."

Mr. Murdock and his escorting caravan, which embraced another Packard, driven by his brother, W. F. Murdock, carrying

## STEARNS FREE-FOR-ALL WINNER IN CINCINNATI HILL CLIMB

CINCINNATI, May 25.—The flight of John J. Ryan's Stearns up the half-mile hill on Stanley avenue in :31 4-5, in the free-for-all, brought to a close what would have been the best day's sport ever seen in this part of the country, had it not been unfortunately marred by an accident to Walter White.

Mr. White, whose driving feats have given him international fame, is now confined in a local hospital with a compound fracture of the right leg and sundry bruises.

The accident occurred in the free-for-all, and the crowd on the course is blamed for it. The White steamer was going nearly 60 miles an hour, and at this high rate of speed it was no easy task to swing out, but White did, and missed the people crowding the course, but he could not avoid a skid which caused the car to turn turtle, pinning him beneath it.

Before he could be picked up, John J. Ryan, in the Stearns, was given the word, and he came up the hill at railroad speed.

He saw the crowd in time, though, and managed to swing by without damage. Following this, though, the chief of police declared he would not be responsible for the safety of the crowd, whereupon the club officials decided to call off the climb. The honors in this interrupted free-for-all went to Ryan, whose Stearns beat the White by 4-5 second. In fact, Ryan really was the star of the climb, and had it not been for a mishap in Class D he would have taken three firsts. In that event he discovered, when half way up the hill, that someone had turned off his gasoline, and he had to be content with third. The officials granted him permission to make a time trial, which he did in :36 3-5.

An added event was a class for electric, and two Babcocks put up a most creditable exhibition, making the hill a full minute faster than the next best performer, doing much to remove the belief that Cincinnati is not for electric. Summaries follow:

### FREE-FOR-ALL—Open to All Classes.

1. Stearns..... John J. Ryan..... 0:31 4-5
2. White..... W. C. White..... 0:32 3-5
3. Pope-Hartford..... A. Hickenlooper..... 0:52 4-5

### CLASS D—Cars Costing \$3,501 and Above.

1. Stevens-Duryea..... P. G. Thompson, Jr..... 0:43
2. Stearns..... A. V. and F. G. Stegeman..... 0:46 3-5
3. Stearns..... John J. Ryan..... 0:54 1-5  
(Special time by Ryan, 0:36 3-5.)

### CLASS C—Cars Costing \$2,001 to \$3,500.

1. Thomas-Detroit..... J. H. Ratliff..... 0:46 2-5
2. Knox..... Queen City Auto Co..... 0:47 2-5
3. American..... Jungclas Auto Co..... 0:50 2-5

### CLASS B—Cars Costing \$1,000 to \$2,000.

1. Jackson..... C. D. Paxson..... 0:57 1-5
2. Overland..... Suburban Auto Garage Co..... 0:58 4-5
3. Klink..... Charles F. Schubert..... 1:13 1-5

### CLASS A—Cars Costing \$1,000 or Under.

1. Ford..... Auto Motor Car Co..... 1:07
2. Reo..... Logan A. Thompson..... 1:22 1-5
3. Jackson..... C. D. Paxson..... 1:22 4-5

### SPECIAL RACE—FOR WOMEN.

1. Thomas..... Miss Bessie Burkhold..... 0:45 4-5
2. Packard..... Mrs. Charles Bultman..... 0:47 2-5
3. Stoddard-Dayton..... Mrs. D. P. Roberts..... 0:58 4-5
4. Pope-Toledo..... Miss H. McD. Stallo..... 1:01

### SPECIAL RACE—FOR CLUB MEMBERS.

1. Stearns..... John J. Ryan..... 0:34 1-5
2. Stevens-Duryea..... E. A. Conkling..... 0:47 1-5
3. Thomas Detroit..... G. H. Ratliff..... 0:47 1-5

### SPECIAL RACE—FOR ELECTRICS.

1. Babcock Electric runabout..... 1:34 1-5
2. Detroit..... R. S. Payne..... 2:24 3-5

## OFFICIAL REPORT OF HARTFORD CLUB'S RELIABILITY RUN

HARTFORD, CONN., May 23.—The official report of H. P. Maxim, referee of the recent reliability and fuel contest of the Automobile Club of Hartford, has been sent to the secretary of the technical board of the American Automobile Association, in which the results of the protests filed are announced. Two protests were received by Referee Maxim.

One was from the Capitol City Auto and Hack Company, entrant of the Mitchell, which objected to the manner in which the gasoline tank of the Mitchell was filled. Referee Maxim explains this by stating that when the tank was filled at the noon control the driver of the Mitchell stated it would take five gallons, so a can of that capacity was used. The tank would not hold the full amount and some of the fuel overflowed, whereupon Henry Souther, who was officiating, estimated the waste at 1 pint, making due allowance on the ticket. This second filling made the Mitchell's total 9 gallons 3 quarts, whereas the

Ford, which was given the decision in this class, used 9 gallons 2 quarts 1 pint. Referee Maxim states that "the decision was based on Mr. Souther's record and judgment, backed up by the judgment as to the amount spilled by a member of the committee present experienced in such matters.

The Mitchell people also protested the Ford because the entry fee was not paid until after one lap of the contest had been completed, whereas the rules called for the fee accompanying the entry. This was dismissed by the referee when it was learned that the Ford entry had been accepted on the promise of the entrant to forward the fee within a few days, his credit being considered good by the committee. The fact that the Ford was allowed to start is blamed upon the committee rather than the entrant. The referee quotes a precedent for making this ruling.

Referee Maxim's report on the condition of the cars and the reasons for the penalization was as follows:

- No. 1 Franklin—Changing tire at Hartford control.
- No. 2 Corbin—Carbureter and engine trouble.
- No. 3 Corbin—No penalty; perfect score.
- No. 4 Ford—Stalled motor.
- No. 5 Stevens-Duryea—No penalty; perfect score.
- No. 6 Reo—Babbit burned out; broken connecting rod.
- No. 7 Stoddard-Dayton—Stalled engine; commutator trouble; tire trouble.
- No. 8 Rambler—No penalty; perfect score.
- No. 9 Ford—Did not start.
- No. 10 Rambler—Car backed down hill changing gears.
- No. 11 Rambler—No penalty; perfect score.
- No. 12 Knox—Stalled motor; tire troubles.
- No. 13 Buick—Engine trouble; faulty spark plug.
- No. 14 Compound—Gearshaft bent.
- No. 15 Stoddard-Dayton—No penalty; perfect score.
- No. 16 Thomas Flyer—Motor stalled.
- No. 17 Overland—Engine, radiator and tire troubles.
- No. 18 Thomas Flyer—Stalled engine; carbureter trouble.
- No. 19 Stevens-Duryea—No penalty; perfect score.
- No. 20 White—Disqualified; ahead of schedule time.
- No. 21 Ford—No penalty; perfect score.
- No. 22 Mitchell—No penalty; perfect score.
- No. 23 Rambler—Tire trouble.
- No. 24 White—Stopped to take on water.
- No. 25 Pope-Hartford—Engine and tire troubles.

- No. 26 Cadillac—Engine and tire troubles.
  - No. 27 Peerless—Engine and tire troubles.
  - No. 28 Oldsmobile—Tire trouble.
  - No. 29 Pope-Hartford—Stalled motor.
  - No. 30 Ford—Did not start.
  - No. 31 Corbin—Withdrawn.
  - No. 32 Knox—Motor stalled; adjusted spark plug.
  - No. 33 Corbin—No penalty; perfect score.
  - No. 34 Columbia—Ignition trouble.
  - No. 35 Thomas-Detroit—No penalty; perfect score.
  - No. 36 Packard—No penalty; perfect score.
  - No. 37 Cadillac—Ignition trouble.
  - No. 38 Pierce-Arrow—No penalty; perfect score.
  - No. 39 Maxwell—No penalty; perfect score.
  - No. 40 Thomas Flyer—No penalty; perfect score.
  - No. 41 Atlas—Tire trouble.
  - No. 42 Knox—No penalty; perfect score.
  - No. 43 Columbia—Leaking radiator connection.
  - No. 44 Mitchell—Carbureter trouble.
  - No. 45 Stoddard-Dayton—Did not start.
  - No. 46 Maxwell—No penalty; perfect score.
  - No. 47 Maxwell—No penalty; perfect score.
  - No. 48 Locomobile—Tire trouble.
  - No. 49 Buick—No penalty; perfect score.
  - No. 50 Oldsmobile—Tire trouble.
- Total. Perfect Scores, 18.



Along the Exhilarating Seacoast of Massachusetts—Near Revere Beach, Not Many Miles from Boston.

MORE beautiful, more ephchanting, more exhilarating; beautiful because of its unsurpassed scenery, enchanting because of its mountains, rivers and plains, and exhilarating on account of its perfect clear air and hemlock and pine essence—this, in brief, is what will make the 1908 A. A. A. tour more popular than its predecessors. Scenic, as all Glidden tours of the past may have been, they will fade into oblivion when compared with the approaching reliability contest for the Glidden and Hower trophies, as laid out by the Premier pathfinder, in charge of Secretary Dai H. Lewis of the A. A. A. touring board.

Tourists could not ask for a better route. Even the chronic faultfinder can find little, if anything, to grumble about with this year's excellent route. The entrants will find mile after mile of beautiful macadam roads, naturally intercepted at intervals with some bad spots, but, taken all in all, the route is over some of the very best roads in the country.

Among the mountain ranges to be traversed are the Alleghanies, the Catskills, the Berkshires, the White mountains of New Hampshire, and the picturesque Green mountains of Vermont. Such rivers as the Susquehanna, Delaware, Androscoggin, Kennebec, White river, and numerous smaller streams will

be often crossed and followed during the tour. The route is:

First day—Buffalo to Cambridge Springs.....	117.4 miles
Second day—Cambridge Springs to Pittsburg.....	110.2 miles
Third day—Pittsburg to Bedford Springs.....	106.4 miles
Fourth day—Bedford Springs to Harrisburg.....	107.3 miles
Fifth day—Harrisburg to Philadelphia.....	133.5 miles
Sixth day—Philadelphia to Milford.....	132 miles
Seventh day—Milford to Albany.....	158.5 miles
Eighth day—Albany to Boston.....	194.2 miles
Ninth day—Boston to Poland Springs.....	154 miles
Tenth day—Poland Springs to Rangeley.....	141.7 miles
Eleventh day—Rangeley to Bethlehem.....	130 miles
Twelfth day—Bethlehem to Saratoga.....	184.5 miles

The total mileage for the tour is 1,669.7 miles. The odometer on the Premier pathfinder registered exactly 1,992 miles.

Previous stories have told of the tour starting from Buffalo, July 9, and taking in the oil, coal, coke, and steel regions of Pennsylvania; the run through the Delaware Water Gap; from Albany to Boston through the Berkshires and over the excellent State highways of Massachusetts to Boston.

While the run through the Delaware Water Gap and over the Alleghanies is through decidedly picturesque country, there

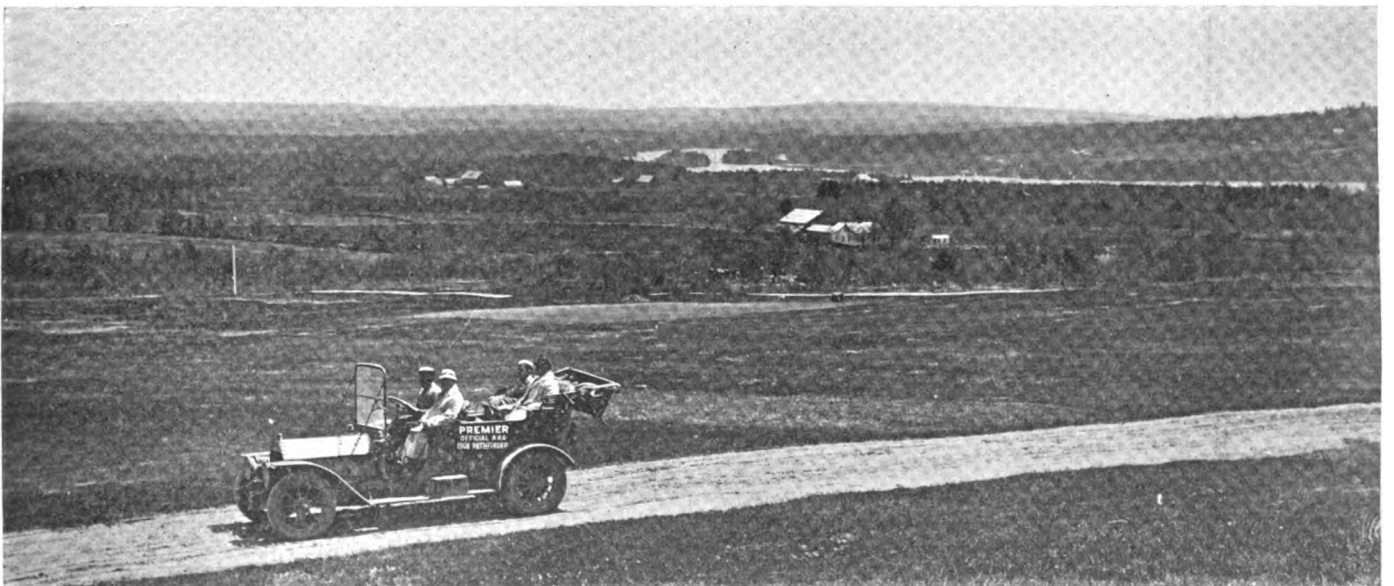

View from Poland Springs, Me., Where the Tourists Most Comfortably Will Spend One of Their Sundays.





Typical of the Road to Rangeley Lakes.

is no question but that the route from Boston to Saratoga, via New Hampshire, Maine and Vermont, will eclipse that of any other section of the tour.

From Boston to Poland Springs it will be by way of Cambridge, past Harvard University, through Somerville to the Middlesex Fells parkway, to the Revere Beach parkway and a two-mile ride along the beach and past the amusement places. This day's run brings the tourists for the first time to the shores of the Atlantic.

From Revere Beach the route leads to Lynn, to the Swampscott boulevard along Swampscott beach to Salem, known as the "Witch City." From here the tourists will pass through Newburyport, Portsmouth, N. H., where a turn seaward is again made to Rye Beach and past Boar's Head. The view of the ocean from this point is excellent.

Maine is entered at Kittery, and at York the Portland post road is traversed, and from there the route is then through a few small lumber camps, while the roadway is strewn with the famous pines, hemlocks, and fir trees of Maine. In the vicinity of Kennebunk there are several stretches of sandy roads. The roads from Boston to Portland are excellent for touring, and no hill was encountered which is larger than a knoll. From Portland the route leads finally to the Summit House, Poland Springs, where Sunday of July 19 will be spent.

From here the Presidential range of the White Mountains can be seen, ninety miles away. Mt. Washington, the highest peak east of the Mississippi, can plainly be seen towering nearly 6,000 feet heavenward. The scenery is magnificent, and in all directions towering mountains are to be observed for miles. It is an ideal spot for a stopover.

The day's run from Poland to Rangeley will be not only beautiful, but one of the hardest during the entire route. The



Logging Settlements Abound in Maine.

route leads through Auburn across the Androscoggin river into Lewiston. To the left of the tourists while crossing the bridge into Lewiston, are the fascinating falls of this river. The run through Augusta, Waterville, and up to Farmington is without particular interest, except for the Kennebec river, which is followed from Augusta to Waterville, and the unusually fine country roads.

Up to Farmington there are very few hills. The route chosen this year from Waterville to Rangeley is not through Skowhegan and the Dead River district, as was the case two years ago. After leaving Farmington, the roads are in excellent condition, with many level stretches up to Strong, twenty miles from Rangeley. From Strong to Rangeley very narrow and rocky roads predominate. The route lies along Sandy Creek. There are many water-breakers, and the Premier pathfinder struck many soft places with practically no bottom. A mile and a half from Rangeley the Premier struck one of these soft spots and sank to the radiator. On one side both hubs and the running board were completely buried in the mud.



Just a Touch of the Maine Atmosphere.

For three hours the car was in this quagmire, which was one of the worst of the entire pathfinding trip. It was slow shoveling, as the soft clay flowed back as fast as it was thrown out. After four hours of digging, filling in with rocks, laying planks and making detours into the field, the Premier reached the hotel with hardly a spoke in sight, so completely were the wheels choked with mud. But it was with some satisfaction that we learned the car was the first to Rangeley this Spring. It will be mid-Summer when the tourists will cover this stretch, and the roads will be seasoned.

A few miles north of Farmington one begins to get right next to nature. The narrow roadway leads into the dense main forest, where Nature is found in all her solitude. It is certainly the forest primeval, and the murmuring pines and hemlocks seemed to wave a welcome to the pathfinders. Great fallen "monarchs of the forest" were stretched on all sides, in many cases forming natural bridges across the streams. Several recently deserted logging camps are near the roadway. None but those who have visited the Rangeley Lakes and who have been through the dense Maine forests can appreciate that glori-



**Rangeley Lakes, a Most Beautiful and Picturesque Mecca for Sportsmen and Vacation Seekers.**

ous country and the "happy hunting ground" of all sportsmen. The air is permeated with the essence of fir, balsam, and hemlock. One can imagine how the Indian savage in the days of yore tramped through these forests hunting deer and bison, and skimmed over the forty miles of lakes in his birch bark canoe. For rest of body and contentment of mind, there is no more ideal spot.

While laying over a day at Rangeley waiting for the roads to dry, the pathfinders, armed with fishing tackle, made an attack upon the lake. Ray McNamara, the driver of the Premier, had not been there an hour before he pulled out a four-pound salmon. Secretary Lewis caught a trout about four inches long, and of course threw it back.

From Rangeley to Bethlehem, the following is the route: Madrid, Weld, Dicksville, Rumford Falls, Shelbourne, Gorham, circle Cherry Mountain, and Carroll. The beauty of the White

mountains, especially the Presidential range, is well known to Gliddenites. Among the many wonderlands of this vast continent none possess the variety of attractions of the White mountains. The Alps themselves afford no greater marvels of natural phenomena in the way of scenery, climate, and exhilarating environment than does this famous region.

The last day of the tour, a distance of 184.5 miles, between Bethlehem and Saratoga Springs, will not only be one of the hardest but the most beautiful. The route is through the magnificent Green mountains of Vermont, and includes Littleton, Lisbon, Newbury, Bradford, Hanover, past Dartmouth College, White River Junction, Woodstock, Bridgewater, Rutland, Castleton, Fair Haven, Whitehall, Glens Falls, to Saratoga.

The roads are in excellent shape until reaching the Green Mountain Notch where a climb of three and one-half miles will be made, reaching an altitude of 4,600 feet. This is a very



**Vermont Offers Much in the Way of Green Clad Hills and the Captivating Connecticut Valley.**

mountainous, narrow, and rocky road. During the day's run the Connecticut river was crossed at Wells river, Vermont, and the contestants will pass through the Connecticut valley and the White river valley. White river is followed and crossed many times from White River Junction.

To attempt faithfully to portray the beauties of Vermont scenery by means of printer's ink is no easy task. It is by far the most glorious country through which the contestants will pass. It is territory through which the Glidden tour has never been run. Even the camera's vision, while it may reproduce in piecemeal suggestions of sublime symmetry and enchanting vistas, cannot reveal the wider scope and prospect of unfolding beauties that greet the admiring eye on every side. The scenery of Vermont is not of magnificent, awe-inspiring grandeur, such as is characteristic of regions in this country where the Titanic upheavals of ages gone have reared colossal snow-crowned domes and gigantic gorges. Nature was in her gentler mood when she fashioned her handiwork in the Green mountains. The scenery is of the restful, pastoral kind, an undulating country of wonderfully verdant fields and hillsides, dimpled with tiny ponds and lakes and babbling brooks.

While the Premier pathfinder was greeted with enthusiasm during the entire trip, the welcome which it received through



At Hanover, N. H., Dartmouth College Is Located.

### DEMONSTRATIONS AT A. A. A. CONVENTION.

BUFFALO, May 25.—Work is rapidly being pushed for the completion of the preparations to receive the visiting delegates to the Good Roads and Legislative convention of the American Automobile Association, to be held here July 7 and 8. The Committee on Practical Demonstrations, of which George C. Diehl, county engineer of Erie County, is chairman, has invited manufacturers of road machinery and makers of preparations for dust laying and road binding, to be represented at the Buffalo convention. About four miles of improved road will be set aside for the use of manufacturers of dust preventives, each being given a short strip, properly placarded, and the different applications will be subjected to heavy wear, the results being publicly announced later. Lateral roads in the same neighborhood will be turned over to the makers of road building machinery in order that they may demonstrate their apparatus thereon.

From the number of inquiries that are being received daily at the office of the Touring Board of the three A's in this city, it is evident that Buffalo will prove a Mecca for a very large number of runs and tours which are now being planned to bring their participants here in time to take part in the convention. These inquiries ask for routes, garage and hotel accommodations and similar information and come from various parts of the country within a radius of several hundred miles. President Strong, of the Rochester Automobile Association, has informed President Hower of the Automobile Club of Buffalo, that the Rochester club has organized a run to the convention in which about 200 will participate, quarters having been engaged at the Lafayette.

On the nomination of President Hower, President Hotchkiss of the A. A. A. has appointed a number of committees to assist the national officers in receiving and entertaining the delegates and visiting autoists. These committees and their chairmen are: Finance, H. A. Meldrum; reception, A. H. Knoll; entertainment, John L. Clawson; practical demonstrations, George C. Diehl. The committees in each case are composed of a large number of prominent autoists of this city, most of whom are members of the Automobile Club of Buffalo.



Mount Washington Looms Up Through the Clouds.

the White mountains district clearly showed that the farmers of New Hampshire welcomed the coming of the Glidden tourists. In this section people rushed to the front of their stores and houses, the men sending up a cheer and the women and girls waved their handkerchiefs. Many times the question was hurled after the pathfinders: "Is the Glidden tour coming this way?" Team drivers graciously turned to the side of the road and gave the car plenty of room, while in some other sections of the trip we found many "road hogs."

It would be doing an injustice to the Premier pathfinder, if at this time a tribute was not paid to the magnificent work which the car did on the trip. None but the pathfinders can appreciate what a terrible twenty-four day siege of spring mud-plugging and mountain-climbing this car went through. No car in America was ever given a harder test and when the route was completed at Saratoga, the powerful six-cylinder machine was running as smoothly as when it left Buffalo. We were particularly fortunate in having no punctures or blowouts during the entire trip—the tires used were Goodrich. No replacement was made on the Premier pathfinder, so that the run was as peaceful and uneventful from the mechanical point of view, as it was enchanting from the scenic.

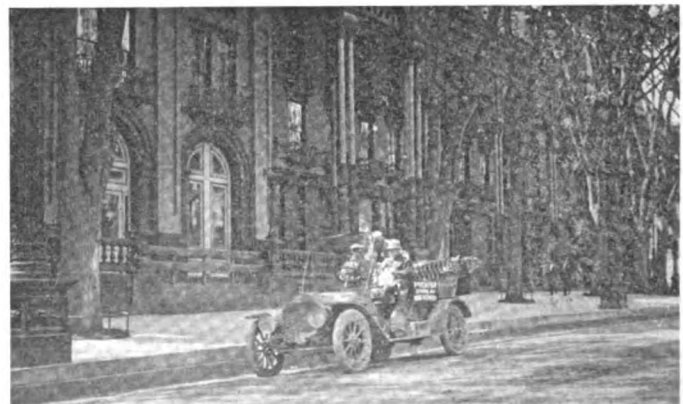

And, Finally, the Pathfinder Reaches Saratoga.

# AUTOMOBILE CLUTCHES AND THEIR DESIGN\*

By HENRY SOUTHER, MEMBER A. S. M. E. AND S. A. E.

THE single disc clutch is widely used, here and abroad. It is so characteristic of a French make as to travel under the name of the firm—the De Dion. It is now used in this country by one firm for horsepowers ranging from 70 to 20, for pleasure and for commercial service. The clutch has a disc *A*, Fig. 35, on the driven member, *B*, which is clamped between two discs, *C*,

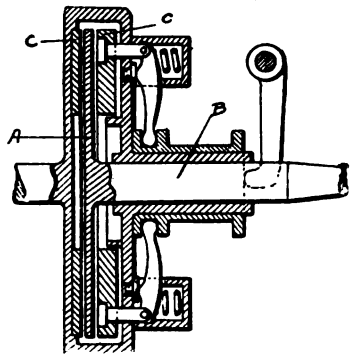

Fig. 35—A single disc type.

on the driving member or flywheel. In Fig. 35 this arrangement is clearly shown. There are the necessary accompaniments of separating springs, so as to make disengagement perfect, also either single or multiple springs to cause the proper engagement.

Fig. 36 shows the same kind of a clutch in a slightly different form. The springs in this case are on the front side of the flywheel rather than on the rear, as in Fig. 35. Cork inserts are being

used in this clutch to considerable advantage. Another form is the now popular multi-disc clutch; that is, the elaboration of the Weston clutch, to which I have already referred. This clutch is indicated clearly by Fig. 37, the alternate plates of bronze and steel attached to driving and driven parts being pressed together by a powerful spring, *5*. The question of lubrication here is the all-controlling one, and, in fact, it would seem that the principal problem in connection with the multi-disc clutch as a type is the proper lubrication of it.

I have ridden in cars equipped with such clutches that were extremely savage in taking hold. I have ridden in others of the same make that were extremely slow to take hold. In a way, this may be a good thing. For example, a person going into a hill-climbing contest or race and wishing to pick up quickly would be perfectly willing to put up with a harsh clutch and lubricate accordingly. On the other hand, a car running about a level city, encountering few bad hills, would be able to lubri-

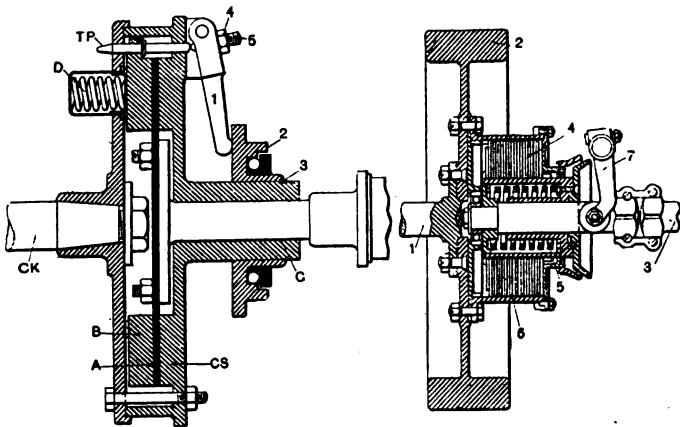

Fig. 36—Modified disc design.

Fig. 37—Form of multiple disc.

cate excessively and still have a satisfactorily driven automobile. A clutch so lubricated would be extremely soft, and yet pick the car up fast enough for ordinary purposes on level roads.

Cold and heat affect the operation of this clutch, the lubricant

in summer being thicker than can be permitted in winter. As it runs in oil it takes a certain length of time for the oil to squeeze out when engaged and for the metal to come in contact with metal and really begin to drive the car. It will be seen from this that the viscosity of the lubricant is of prime importance. One form of multiple disc clutch in use in a very high grade car consists of steel discs rubbing against a special bronze rolled into sheets. The steel discs are provided with several small tongues on the outer periphery, bent one side sufficiently to come in contact with the next steel disc, for the purpose of separating the discs and overcoming the drag when the clutch is disengaged. A small clutch brake is also provided to overcome clutch inertia or drag inherent in the clutch and due to viscosity of lubricant. The steel discs are put into the clutch as received from the rolling mill, with the hard black finish characteristic of carefully finished crucible sheet steel.

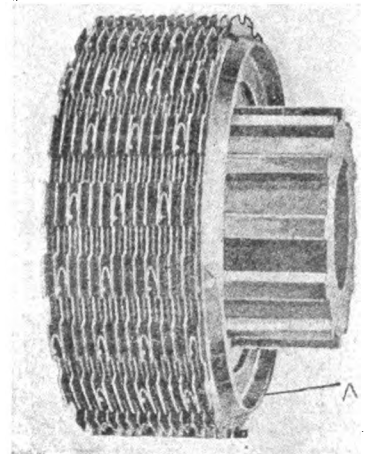

Fig. 38—Assembly of discs.

This clutch is connected with the crankcase so that oil feeds into it from the crankcase through a hole drilled in the center of the crankshaft. Entire reliance, however, is not placed on this supply, a little extra oil being supplied every two or three days through holes provided for that purpose. Fig. 38 shows a nest of discs such as used in a well-known multi-disc clutch. The U-shaped separating springs are plainly visible. These force like discs apart when the spring pressure is released, overcoming the natural tendency of the oil to cause them to adhere. Some disc clutches are forced apart in a similar manner by little spring shaped strips struck up from the discs themselves. Another form of this same type of clutch is shown in Fig. 39. Comparatively few discs are used as will be noted. On the other hand, it is apparent that the spring pressure is very heavy. This is a successful and well behaving clutch used on a popular car at the present time. It drags but little when the gears are changed and is satisfactory in that respect.

A type of disc clutch consisting of all steel discs with alternate ones faced with leather was operated without any oil whatsoever, the leather being softened and made more or less pliable like the leather on the simple cone clutch. These clutches gave some trouble by burning up, the slip required to start smoothly being also sufficient to create enough heat to destroy the leather. This clutch was, however, extremely efficient in the transmission of power. For example, the one shown in Fig. 41, the discs of which are about 7 inches in diameter, was powerful enough to drive an automobile of 50 horsepower.

It must be remembered that the automobile engine runs at high speed, say, 1,000 to 1,200 r.p.m. when developing anywhere near its normal rating. Some motors, in fact, running up as high as 1,500 to 1,800 r.p.m. (standard rating is at 1,000 feet per minute piston speed). It is a fact that in service cars with disc clutches of this character vary more or less in the way their clutches behave. Clutches receive very much less attention than they ought, like everything else on the automobile. I think it will be admitted, even by the adherents of this form of clutch, that it ought to receive more attention than the leather-faced

\*Paper read before the American Society of Mechanical Engineers at New York, May 12. Discussion to be continued at Detroit, June 25-28, in conjunction with the Society of Automobile Engineers. Continued from page 707, "The Automobile," May 21.



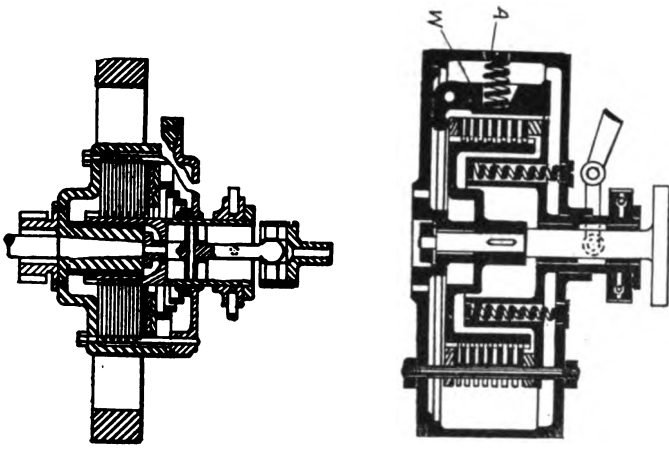

Fig. 39. Modifications of Multiple Disc Types.

cone. Nevertheless, this is now a very successful type of clutch, largely used in many high-grade cars.

In the matter of the number of plates in the disc clutch there is no agreement between designers. Some use a very large number of thin plates, as many as 50 or 60, and others use a very small number, as few as six or eight; in fact, it may be said that the single disc clutch, which has only two frictional surfaces, is the lower limit. One very ingenious application of the multiple-disc clutch has been made by a manufacturing concern in the East (Sturtevant Mill Company, Boston) in the fact that the pressure on the discs is brought about by centrifugal force acting on weights so arranged as to press the tighter with increased velocity. This is shown by Fig. 40. One of the weights is at *W*. It will be noticed that this weight operates against a spring, *A*, which prevents it flying out and gripping at too low an engine speed. Once, however, this spring pressure is overcome, the discs indicated by the alternately light and dark spaces are pressed together. It would seem that this principle has one serious defect in the fact that at low engine speeds the gripping tendency would be small. It would, therefore, not be possible to develop high torque at low speeds, which is sometimes quite desirable. It is a fact, however, that it is almost impossible to stall an engine by applying this clutch too quickly, as it does its own releasing so promptly and automatically. It is almost human in this respect.

This principle has been elaborated in connection with an automatic change of gears: gear No. 1 being picked up at a given rate of revolutions by its set of disc clutches; gear No. 2 by an increased number of revolutions by a separate set of discs, and so on. In driving a car so equipped the changes take place without being perceptible except with the closest observation. This system is open to the objection, however, of not being able

to spin the engine up very rapidly and connect with the low gear, in order to jump the car out of a hole or some unusual situation. I understand this has been overcome by supplying an independently operated lever for the foot to be used in emergencies only.

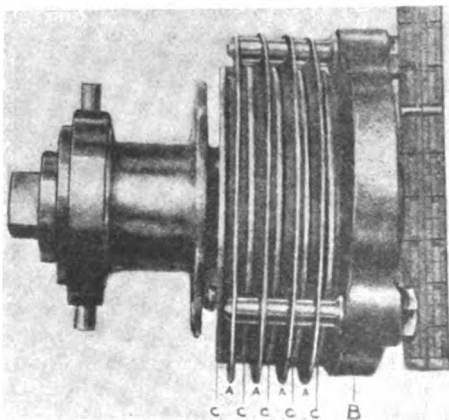

Fig. 41—Showing small dimensions of the average multi-disc type of clutch.

With the automatic Sturtevant multi-disc clutch it has been found experimentally that, for the maximum slip speed usual in automobiles, 15 to 20 pounds per square inch pressure is safe, and the lubricated cast iron discs scarcely wear out the tool marks after many thousands of miles use. They further state that experience has shown them that safe slip is merely a matter of good lubrication and low pressures. They have experimented with small cast iron discs, running dry and with constant slip at two pounds per square inch pressure, and even at that they wore many weeks transmitting a heavy load.

A modification of the multi-disc clutch in which the cone and the disc are combined is attracting much attention. This clutch (Hele-Shaw) is fully described by its inventor in the Transactions of the Institute of Mechanical Engineers (Great Britain), July, 1903. Fig. 38 shows a set, or "pack," of discs from such a clutch. Careful scrutiny reveals a V-shaped circular impression struck up in the end disc. Fig. 42 also shows the V shape of the discs very well indeed; in fact, the whole clutch is well shown here in section. I call attention to the female cone, *D*, bearing on the male cone, *f*, when the clutch is thrown out, thereby checking the spinning tendency of this clutch, or, if the viscosity of the oil is heavy, holding it quiet during the changing of gears.

In place of the entire surface of the discs bearing, only the V portions engage. This clutch is copiously lubricated, and the V, or engaging portions of the discs, are perforated with holes

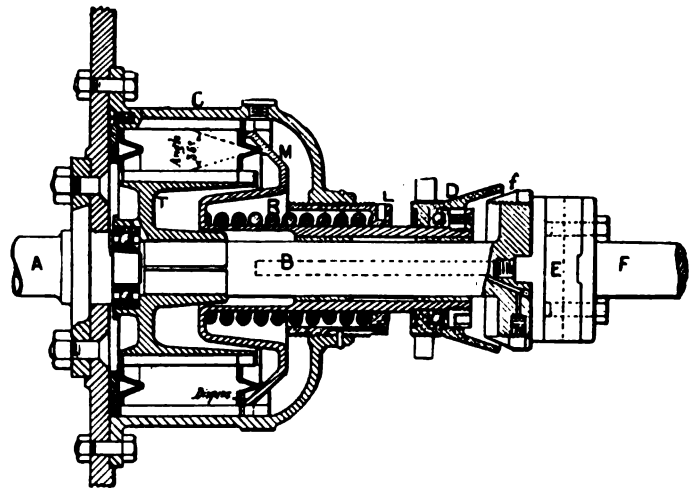

Fig. 42—Combined cone and multiple disc idea in Hele-Shaw clutch.

so that the oil may circulate quickly in and out of the V grooves as they are engaged and disengaged. Outside the V portions of these plates or discs there is a comparatively large space between them, permitting the free circulation of oil and consequent rapid carrying away of heat if the clutch slips much.

In connection with the article referred to in the Transactions of the Institute of Mechanical Engineers there are some very good data on power transmitted by various spring pressures, given in Fig. 43. Fig. 44 shows the character of the curve depending upon horsepower and pressure of springs.

One thousand horsepower is being transmitted by one of these clutches running at 700 or 800 r.p.m. and measuring 18 inches in diameter between the Vs in the discs. The following table gives the dimensions and number of plates used for different horsepowers:

	Bronze	Steel
25 h.p., 27 plates of 6 1-2 in.....	14 outer	13 inner
40 h.p., 25 plates of 8 1-2 in.....	13 outer	12 inner
60 h.p., 21 plates of 11 in.....	11 outer	10 inner

The space in length required inside of the clutch casing for 25 plates is 5 in., this including the space for the disengaging movement and the spring pressure plate.

The number of plates in this clutch is made to vary with the power transmitted, the diameters remaining the same within certain limits. The principle involved is that the thickness of the pack of plates shall not exceed the diameter of the plate. When

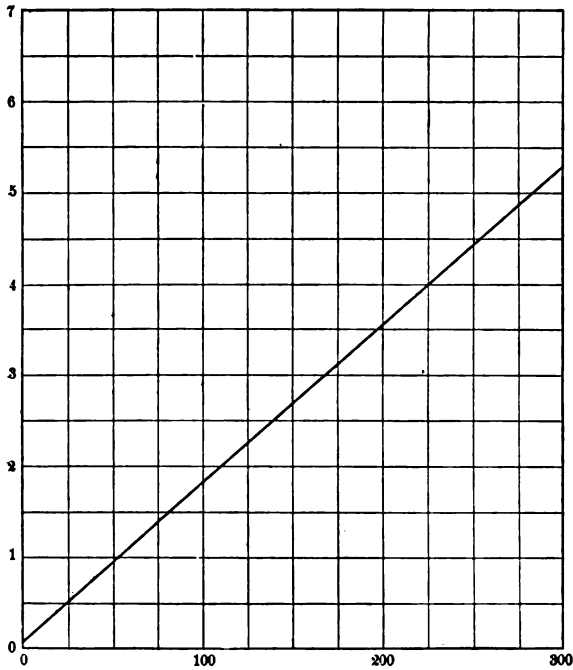

Fig. 43—Power chart for the Hele-Shaw multiple disc clutch. Figures at the right = horsepower; those underneath, pressure.

this becomes necessary in order to transmit a load, the plates are increased in diameter, fewer of them being used. The clutch is necessarily heavy, but this is partially offset by the relatively small diameter. It has, consequently, little spinning tendency. The materials for disc clutches in general have been various; namely, steel on steel, steel on leather-faced discs, steel on bronze and steel discs with cork inserts. I have recently been informed of a disc clutch with cork inserts of natural cork that wore out in about 1,000 miles twice in succession. This same clutch was equipped with compressed cork inserts previously described, which have driven the car some 5,000 or 6,000 miles without perceptible wear.

It is a fact that steel discs against steel have become badly heated and cut to such an extent as to make the clutches inoperative.

Steel against bronze, however, does not seem to cut in this manner and the wear after two years' steady use is only 0.002 inch or 0.003 inch at the outside edge of the discs. I have not heard of the original combination of Weston, that is wood against iron or steel, being used in connection with automobiles. The cone clutch stands alone in the great care necessary to so construct it as to permit it to seat itself absolutely concentrically. All the other types of clutches are for the most part free from this difficulty. But

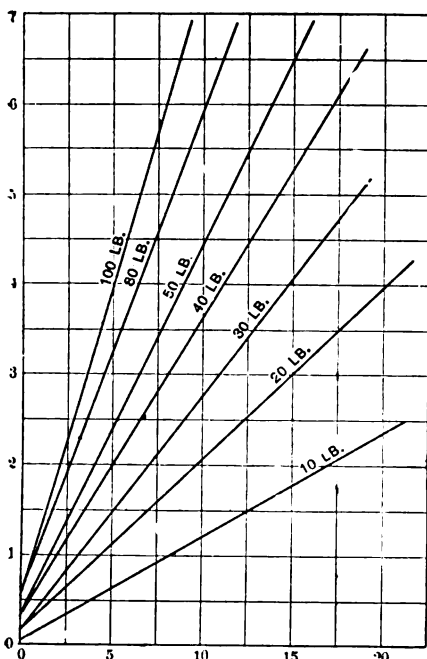

Fig. 44—Chart of spring pressures. Figures at right = horsepower; those underneath = number of plates.

it will be seen from the foregoing that the simplicity of the cone offsets the extra care necessary in its installation.

It may seem from what I have said in regard to clutches in general that it is about the worst part of an automobile that can be mentioned, but I hasten to correct this impression if it exists. As a matter of fact, I find reference to the behavior of the clutches in the last Glidden tour, a tremendously severe test of some 1,500 miles. An observer states that the clutches came out of this test quite as well as many parts of the running gear. My own experience is that it is a mighty poor automobile clutch that cannot be neglected and cannot run without any attention whatsoever for 1,000 miles.

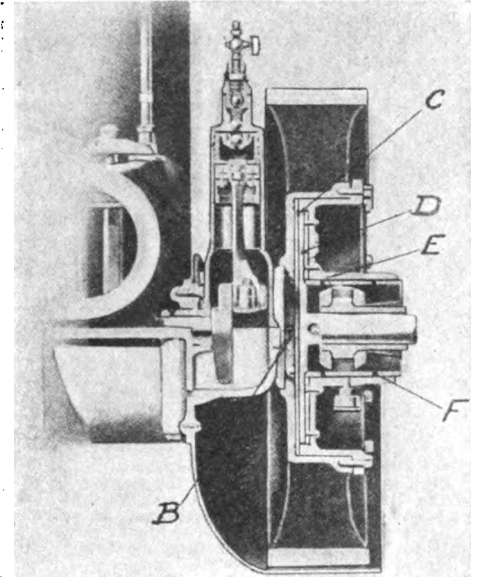

Fig. 45—The Northern pneumatic clutch.

A pneumatic clutch has been developed which has not been widely used because of its cost. It is a plain leather-faced disc pressing a metal plate as indicated in Fig. 45. The clutch is located within the flywheel and the air is forced from the pump through a small air cushioning tank and from there it enters the clutch through the hollow crankshaft B and an air valve. The air deflects the leather diaphragm C, causing it to bear against the metal disc D, which can have a slight endwise motion, and forces it against the fiber disc E permanently riveted to the casing F, which latter is bolted to the flywheel.

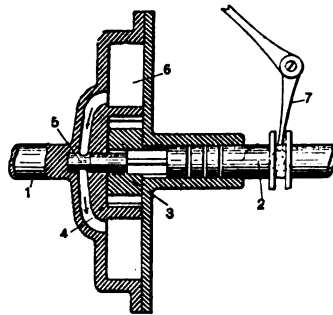
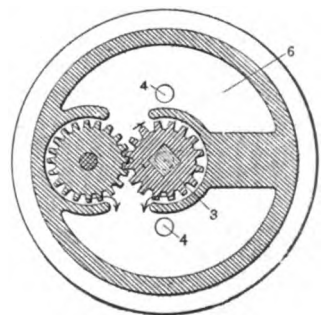

Fig. 46. Simple Form of Hydraulic Clutch.



Hydraulic clutches have been used but are not popular. Figs. 46 and 47 show one of the simpler forms that has appeared. The magnetic clutch is in use and is fairly successful. Such clutches are operated on the same principle as the so-called "pick up magnet" found in so many plants. One complication arises in the fact that one of the parts of the magnet has to rotate continuously, the gears being always in mesh; consequently the exciting current has to be carried to it by a brush. A considerable current is also necessary on the car for the operation of the clutch. As I have already stated, there is a great variation of detail in friction clutches. This paper cannot cover it all, but will, I trust, be of enough interest to lead to discussion, which will do more to fully develop the state of the art than has been possible in this summary which I have prepared.

## TO CHECK VALVE-TIMING FOR MAXIMUM EFFICIENCY

**A**N apparatus known as the Larrad, has been produced with the object of regulating the timing of a motor in order to produce the maximum of power. It consists, writes Louis Lacoïn in *Omnia*, of a metallic plate *A* mounted on a shaft *E*, to which is attached the blade *D* and a spirit level *B*. The metallic plate is pierced with three series of holes, and in the base of the spirit level are three holes to correspond with each of the three series on the plate. Finally the milled nut *C* allows the holes in the two pieces to be brought into correspondence.

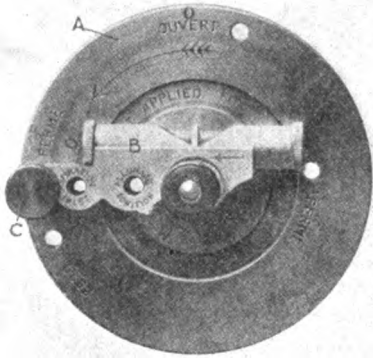

Fig. 1—Larrad apparatus for regulating the timing of motors. A, disc pierced with a series of holes; B, spirit level, in the base of which is a hole for each of the preceding series; C, pin to secure holes in different positions. Arrow indicates direction of rotation.

Its construction allows of a variety of methods of mounting; thus, it may be slightly bent and wedged between the cone and the flywheel. The only essential conditions are that the shaft *E* should be parallel with the crankshaft, and that when the motor is turned over the apparatus should describe a cylinder and not a cone around the motor shaft. When the cone *A* is mounted on its shaft *E*, it should be possible to make a complete revolution of the crankshaft. This is a condition often difficult to obtain with the motor mounted on the chassis. It is possible to attach the apparatus to the cranking lever, though this is not to be recommended, and the better way would be to place the motor temporarily on Hoel's.

Supposing now that the blade *D* is fixed to the motor, that the shaft *E* is exactly parallel with the crankshaft, and that the whole apparatus has been attached to the shaft *E*. The first operation is to make the hole, *exhaust*, correspond with the hole, *zero*, which indicates the upper dead center. The motor is now revolved until the piston has reached the upper dead center, and the plate *A* is turned round until the spirit level attached to it indicates a perfectly horizontal position. At this point the thumb screw is tightened up, thus securely attaching the plate *A* to the shaft *E*, and the apparatus is ready for service. (See left hand drawing of Fig. 3.)

To regulate, for instance, the exhaust valves, the pin *C* is withdrawn and placed in the holes noted; this time the motor

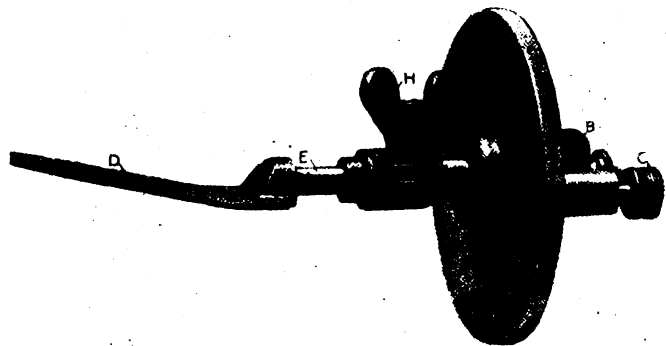

Fig. 2—Profile view of the Larrad. A, disc; B, spirit level; C, pin; D, blade for attaching; E, shaft to be fixed parallel with the crankshaft; H, winged nut fixing disc A to shaft E.

is turned over until the horizontal has been obtained, this being the exact position at which the exhaust valve should commence to rise (center of Fig. 3). All other timing is done in the same way, without dismantling the apparatus from the motor. Thus, for the closing of the exhaust valve (right of Fig. 3), the pin is placed in the hole *exhaust* of the base of the spirit level and the hole *closing* of the plate, and the motor turned until the spirit level indicated that a horizontal position has been obtained again.

It is hardly necessary to point out here the methods of modifying the timing of a motor. The Larrad apparatus, also, only indicates the positions of the crankshaft corresponding to the different cycles of the motor, leaving it to the mechanic to lengthen or shorten the tappet rods or change the position of the cams on the shaft in order to obtain the opening of the valves or the production of the spark at the point indicated by the apparatus. It should not be overlooked in employing the instrument that the cycle of a motor occupies two revolutions, and that the Larrad apparatus does not indicate during which of these revolutions the timing takes place.

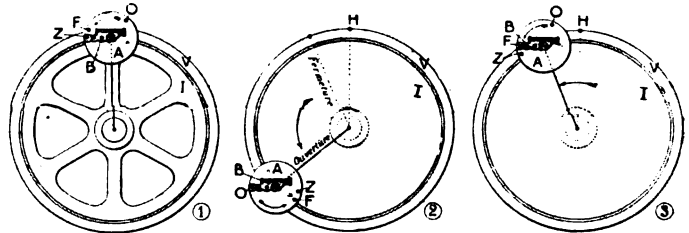

Fig. 3—Larrad apparatus mounted between the cone and flywheel. 1, Position of upper dead center; 2, position of opening of exhaust; 3, position of closing of exhaust. A, disc, pierced with holes; B, spirit level; F, closing of exhaust; H, dead center point; I, clutch cone; O, opening of exhaust; V, flywheel; Z, upper dead center point.

As will be readily perceived, the apparatus is easily employed and permits of minuteness in the regulation of a motor. By thus eliminating vague groping, it should become of considerable service to constructors if they would modify the disc and pierce it in a manner to correspond with their own engines. Unfortunately the inventor has only made one type of disc, his idea probably being that his type was the only perfect one.

### MICHELIN TOURING GUIDE IN ENGLISH.

There is no necessity for eulogy in connection with the guide books published by the Michelin Tire Company of France, Italy, and America. The mere fact that the French guide has a certified circulation of 60,300 copies for 1908 and is in the hands of every autoist touring France is sufficient proof of its value. Though consisting of over 600 pages, it is produced of such dimensions and in such a compact manner as to be carried in the pockets of a car without any inconvenience and to be consulted with the greatest facility. In addition to information on practically every town in France and detail maps of the most important cities, there is a complete sectional map in colors of the whole of France and very detailed maps in two colors of the most important cities. Very complete touring information is supplied, and there is a quantity of interesting matter on tires well worth the consideration of all automobilists.

Owing to the large number of English-speaking people making use of the Michelin guides for touring in Europe, the company has decided to reproduce the complete volume this year in the English language. This edition, which will be as complete in every respect as the French volume, will make its appearance in a few weeks. The Michelin guides are distributed free to all autoists desiring a copy and can be obtained from either the Paris headquarters or the American factory at Milltown, N. J.

## LETTERS INTERESTING AND INSTRUCTIVE

### STARTLING SCHEMES OF AN OLD INVENTOR.

Editor THE AUTOMOBILE:

[1,377.]—You are a good judge of auto schemes. I have a scheme that I believe will take. It is this. With my boiler (a coal burner) I can evaporate far more water than any auto boiler made, as I can get three times the heating surface. I can make a one-seat auto that can make 100 miles in one hour on a racetrack, and with my steel tires with corks in it will not skid, and I can turn corners much faster than a rubber-tired car. My scheme is this: make such a car, then challenge any gasoline auto for a race on a track at Coney Island. Now, in your opinion, would there be a large crowd to see the race at 25 cents admittance, the race to be 100 miles? I am set back a couple of weeks with my auto on account of a flaw in one of the boiler heads. I had to send it back to New York to get a new head. I hope to call on you with the car by the middle of June.

I also have a scheme to keep the car from upsetting going round curves. I will place a pole 8 feet long on the left side of car, hinged so as it can be raised upright when on straight track and let down horizontally going round curves, and an athletic boy to slip out to the outer end of the pole, then slide back as the turn is made. This, with the corks in tires, will enable me to go fast turning corners without danger of upsetting. I will burn coal in this, my first auto. I can make steam much faster with coal over either gasoline or kerosene. I deliver the gases from outlet under the car floor, nothing being visible in the fire box.

Oneonta, N. Y.

W. W. HAZELTON.

With a good promoter back of it, such a scheme as you outline in the first part of your letter, should be a success, as the crowd that flocks to Coney Island on holidays and Sundays in summer is quite willing to pay to see anything novel in the way of a sensation—the more sensational it is, the better.

Regarding your proposed method of preventing a car from overturning in rounding a curve, we are not quite so optimistic. It would be out of the question to try it on tracks as constructed at present owing to the fence that surrounds the inner field. Why not substitute a sliding weight, that could be pulled out or in according to the requirements, for the "athletic boy"? Although there would be no great difficulty in getting someone foolhardy enough to take the risk. The weight would be a little more positive method. It would be out at the end of the pole when you wanted it and you would not be so apt to lose it by the way.

### WHO CAN SHED ANY LIGHT ON THIS MYSTERY?

Editor THE AUTOMOBILE:

[1,378.]—Probably you would be kind enough to help me out on the question of circulation of water through a six-cylinder engine with a gear pump.

What is the cause of the water heating down through the pump after running the engine 5 or 10 minutes? I have had the pipes from the pump disconnected, also the one from the cylinder to the radiator, and attached the garden hose to the same, and forced a stream through cylinders. I also tried the radiator the same. I then filled the radiator, started the engine, and the pump pumped the radiator empty. I tightened the fan belt, so that is O.K., and adjusted the carbureter in every possible way. Have it at present very nearly closed, so that the mixture is as weak as is possible to make it run. Therefore, with no stoppage in the radiator, not any in the cylinders, or pump, I am at a loss to solve the mystery, and light on the matter would be much appreciated.

Portland, Pa.

M. B. HAUSER.

With the small quantity of water carried on the modern car, and the rapidity with which it is circulated, it is nothing out of the ordinary for it to become warm throughout the entire circulating system, after the motor has been running for ten minutes, so that if this is the only thing complained of, we do not see that there is any fault to be found. You do not say that the motor overheats badly, water boils away or anything of the kind. The only time the water should really be cold is when the motor has not been running for an hour or more; otherwise, it should be as hot as it can be maintained, short of boiling, and with the motor running steadily, there will not be a great deal of difference between the temperature in the jackets and at the pump.

### WHICH IS THE EASIEST ON THE MOTOR?

Editor THE AUTOMOBILE:

[1,379.]—We have ordered a seven-passenger, six-cylinder touring car of 54-horsepower, A. L. A. M. rating, and 36-inch wheels. The maker wishes to have a ratio of 2.5 to 1, and claims that it reduces the wear on the engine. It seems to me that a ratio of 3.5 to 1 would be better for such a hilly district as Pittsburg. If the engine is running faster, it is not straining as much, so I think the wear would be nearly the same in each case. A car geared 3.5 to 1 would be easier to run through the city, and better for touring in this locality, as it could accelerate more rapidly between the water-breaks which are so abundant near here.

Please explain fully the pros and cons of this matter, as it has been the source of many arguments.

Allegheny, Pa.

MURRAY FAHNESTOCK.

The reason for providing a car with a certain gear ratio, is to enable its motor to run at its normal speed, or at as near that rate as possible, while the car is travelling under different conditions. Thus gearing a car very low, would make it necessary to overspeed the motor in order to obtain a fair speed on the level, though such a car would be in its element on the hills and should climb anything "on the high." Gearing it up, on the other hand, would make it very fast on the level without the necessity of speeding the motor above normal, but it would make a poor car for hill-climbing or city use. Most designers have attempted to strike a happy medium by adopting something that will not go to either extreme, and thus be found suitable for the use of the greatest number without alteration. But such an expedient naturally does not fit a car for particular uses, such as that you wish to put your new machine to.

With regard to the argument put forth by the maker, a certain gear can hardly be said to reduce the wear on the engine, unless the car with that particular gear is used more or less constantly in a locality adapted to it. A very high-g geared car will have to strain its motor constantly in a hilly district, at least where the nonsensical practise of trying to drive it over all kinds of hills on the high, is followed, as the motor will be called upon to deliver its maximum power at a speed considerably below its normal r.p.m. rate, and will have to labor to do so. But a car with a very low gear will be equally abused where driven constantly on level roads, owing to the necessity of racing the motor to obtain higher car speeds. We should advise the adoption of a 3 to 1 gear for the car you have in mind, and this with the logical and reasonable use of the shifting lever wherever required, will give a machine that will have more than enough speed on the level, coupled with the ability to climb anything in the way of a hill, with its full load up.

### DIFFERENCE BETWEEN NAPHTHA AND GASOLINE.

Editor THE AUTOMOBILE:

[1,380.]—Will you kindly answer, through the columns of your paper, the following question given below?

What is the difference between naphtha at 74 degrees and gasoline at 68 degrees? Would naphtha testing 74 degrees be all right to use in an automobile, and would I realize any more power than using gasoline testing 64 to 68 degrees?

SUBSCRIBER.

Milford, N. H.

In this country, naphtha is merely a trade name as commonly used and where called for in the ordinary course of affairs, the substance supplied is naphtha, gasoline or benzine, as the tradesman happens to designate it. Originally, the term was employed to indicate one of the lighter distillates of petroleum, and is only distinguished by the difference in density or specific gravity. It is not a totally different substance, though there appears to be a popular misconception on this point. Crude oil is separated into its components by means of what is known as fractional distillation, the temperature being controlled during the process in order that the various substances may be evaporated consecutively in the order of their relative densities. Prof. C. E. Lucke classifies petroleum distillates as follows: Petroleum ether, 85



to 80 degrees Baumé; gasoline, 80-78 degrees; naphtha, three grades being enumerated, 78-60 degrees Baumé. Then comes kerosene, and next lubricating oils. The Baumé scale must not be confused with specific gravity, as is so commonly done, 80 degree gasoline having a specific gravity of .66. Garagemen and supply dealers commonly regard these terms as interchangeable, consequently what they offer as "72, or 74 gasoline" may, in reality, be something not far from kerosene, the specific gravity of which is .753, or higher, but the density of which ranges from 56 to 32 degrees Baumé.

It is a matter of common knowledge that the refiners no longer find it profitable to attempt to market the lighter distillates, owing to the very small quantity contained in crude oil. Hence, there is very little fuel to be had on the market at present, lighter than 64 to 68 degrees Baumé, or .70 to .72 specific gravity. This will answer your query regarding the difference between gasoline and naphtha. The difference in the fuel values of the different distillates ascends as they get heavier, kerosene being credited with a slightly greater number of heat units per pound than gasoline, but the heavy liquids are not as available, as they do not vaporize as readily. A slight adjustment of the carbureter may be necessary to take care of the difference in fuels, but this is not ordinarily the case except where maximum economy is aimed at, so that you will find practically no difference in the action of the motor on the fuels you mention.

#### WHAT IS THE CRITICAL SPEED OF THIS CAR?

Editor THE AUTOMOBILE:

[1.381.]—Please answer the following, under the head of "Letters Interesting and Instructive."

At what speed would a car of the following description consume the least fuel? Motor two-cycle, four-cylinder, 4 1-2-inch bore by 4-inch stroke, geared 3 to 1, with 34-inch wheels.

Would four-inch tires on this car, which weighs 2,500 pounds, be sufficiently large for occasionally carrying seven passengers? What are the gear ratios of the following cars on the high, low and intermediate speeds? Thomas, Stearns, Ford six-cylinder, White Steamer, and Reo.

New York City.

It would be impossible to state what the critical speed of a motor is without more data than you give in your letter, although as a matter of fact, it would not be easy to make calculations that would be much more than an approach to the speed at which the motor in question would run most economically. A cut-and-try method would be the only manner of ascertaining this definitely, and slight influences would be apt to influence this one way or other. Assuming your engine to develop about 30 to 35 horsepower, it would doubtless be found to run most economically at a speed ranging between 25 and 30 miles per hour. At speeds of from 10 to 20 miles an hour it would be comparatively wasteful of fuel, particularly at the lower range of its speeds, and this would again be found to be the case when it reached 40 miles an hour and over, though the increase in fuel consumption is not quite as sudden at speeds higher than the car's critical speed within a certain range, as it is below this point.

Four-inch tires should give very satisfactory service on a car of this weight, and no inconvenience should result from the occasional carrying of overloads, in case the tires are kept well inflated at all times. This is far more important than taking a little extra weight in the car.

After a long wait for the information, we have received the following regarding the Stearns, Ford and Thomas cars. We have received no reply to our inquiries concerning the gear ratios of the other cars mentioned in your letter. On the Stearns, assuming a motor speed of 1,000 r.p.m., the rear wheels make 89 r.p.m. on the low and reverse; 182 on the second speed; 265 on the third, and 360 on the fourth or direct drive, giving gear ratios of 11.35 to 1, 5.5 to 1, 3.7 to 1, and 2.7 to 1 respectively. These figures are not exact, not having been figured beyond one or two decimal places. The sprockets employed to give this result are 24-tooth front and 40-tooth rear. The gear ratio of the Ford six-cylinder car is 3 to 1 on the direct drive, and 7½ to 1 on the low, only two speeds being provided. With a 28-tooth

front sprocket and a 52-tooth rear sprocket the gear ratios of the Thomas Flyer are 12.025 to 1, on the reverse; 9.84 to 1, on the first speed; 5.99 to 1, on the second; 4.22 to 1, on the third, and 2.785 to 1, on the high.

#### GEAR RATIOS OF A THOMAS FLYER.

Editor THE AUTOMOBILE:

[1.382.]—Kindly tell us the gear ratio of a 1908 Thomas car where the bevel gear on main shaft has 30 teeth and bevel gear on countershaft has 44 teeth. The sprockets on countershaft have 32 teeth, and the sprockets on the rear wheels have 52 teeth. Kindly give us your method of figuring same. ADOLF A. GEISEL.  
Springfield, Mass.

According to a blueprint furnished us by the makers of the Thomas cars, the only options given on the 1908 models of the Thomas Flyer, i.e. Models F and K, are 28, 30, 33 and 35-tooth driving sprockets, so that we presume you must have made an error in stating that the sprockets on the car in question have 32 teeth. With 33-tooth front sprockets and 52-teeth rear, the gear ratios are as follows: On the direct drive, 2.36 to 1; third speed, 3.58 to 1; second speed, 5.08 to 1; first speed, 8.35 to 1; reverse, 10.2 to 1. Dividing the number of teeth in the large gear of the drive, by that of the bevel pinion, will give the number of turns that the latter will have to make for one of the former, and the same operation in the case of the driving sprockets will give their ratio. For instance, it is evident that with a 50-tooth gear, driven by a 25-tooth bevel pinion, the latter must make two revolutions to one of the gear, and, assuming front and rear sprockets of the same number of teeth respectively, it is also apparent that their relative rates of speed will be the same as that of the bevel drive on the countershaft. Hence, when on the direct drive, or high gear, the crankshaft of the motor would be making two turns for every one of the countershaft, and the latter would be making two turns for every revolution of the rear wheels, and the gear ratio of the car would be 4 to 1.

#### POINTERS FOR A SECOND-HAND PURCHASER.

Editor THE AUTOMOBILE:

[1.383.]—I am contemplating the purchase of a Darracq (second-hand), on which the former owner made the wheelbase 14 inches longer than the manufacturer. He thought it would ride easier, thus the change. Which would be the better, to leave it as it is, or change it back to where it was when new? What would you do to try it to see if it is O.K.? I have seen it assembled and know that it is in first-class shape, and have seen it running in the stand. It has a new timer, transmission (sliding) and two tires. How long a road trial ought it to have to see if any of the bearings or engine heats up or works loose? DARRACQ.  
Allegan, Mich.

Whether it is advisable to alter the lengthened wheelbase to what it was formerly or leave it as it is, would depend to a very large extent on how well the job was carried out. As you saw the car assembled, you should be in a position to judge of this. The longer wheelbase is an improvement on an old car, as it was one of the worst failings of designs current prior to 1904. It makes a great improvement in both the steering and the riding, and if the change was well done, it would certainly be a mistake to undo the job. From what little you say of it, the car would now seem to be in excellent shape. We should prefer a full day's run of 100 miles or more, as the short demonstrating ride usually given proves nothing except that a car will run without trouble for a short distance. It is valueless as a test of a car.

#### FAILURE TO RESPOND TO THE THROTTLE.

Editor THE AUTOMOBILE:

[1.384.]—I would like to have your opinion, through "Letters Interesting and Instructive," of the trouble with a Schebler carbureter from the following symptoms: The car will not speed up unless the spark is very high, and opening the throttle has no effect at all until it is very nearly wide open, when the car speeds up, but not as fast as it ought. Running slowly with the throttle closed and the spark very little advanced, opening the throttle has very little, if any, effect; but if the throttle is quickly thrown wide open and as quickly closed (without advancing the spark at

all), the car speeds up considerably. The car is also somewhat sluggish, and very slow to pick up.  
SUBSCRIBER.  
New York.

Judging from the symptoms of the trouble that you give, the cause would appear to lie in a deranged auxiliary air-valve. This, particularly from the fact that the sudden opening of the throttle to its full width causes the motor to speed. See if the auxiliary air-valve has not become deranged in some manner so that it does not respond readily, as where this is the case, the mixture becomes overrich, owing to lack of the proper quantity of air, and the motor instead of gaining power and speed, acts very sluggishly. Take this auxiliary valve out and start the motor by closing the secondary air outlet with a piece of cardboard. Then work the throttle, giving more air proportionately to the opening of the latter by sliding the cardboard back from the aperture, and note the result. A little experimenting of this kind should reveal the cause. Clean and adjust the auxiliary valve, replace and regulate in the same manner until the motor runs satisfactorily.

### CAN ANYONE IDENTIFY THIS MOTOR?

Editor THE AUTOMOBILE:

[1,385].—I have an engine, the "paternity" of which I have been unable to trace, and wish to know if you can give me any information that will help me to locate the manufacturers. It has four cylinders, cast separately, valves offset on opposite sides of cylinders mechanically operated, spark plugs in center of cylinder heads, standard (1-2 inch) thread, camshaft, pump and timer gears all inclosed in front of crankcase, connecting rods look like brass. The only marks on it are parts that have a number followed by the letter B.  
H. A.

Brighton, Ill.

The features you mention are characteristic of several motors that we have in mind, barring the bronze connecting rod, that we are not certain of, this part of the motor seldom being exposed to view. But they are not sufficiently distinctive to narrow the choice down to one, so far as we are concerned, so we are referring the query to our readers, some of whom will doubtless have had experience with the same make of motor and can name it offhand. If some subscriber who is in a position to do so will supply the necessary information it will be published in these columns, or transmitted direct to the inquirer.

### DOES POOR TIMING CAUSE THIS TROUBLE?

Editor THE AUTOMOBILE:

[1,386].—Through "Letters Interesting and Instructive" please advise me in regard to this annoying trouble. Have a Maxwell runabout which pounds in one cylinder running light or under load, spark advanced or retarded, but ceases when run with this cylinder dead. Have lengthened the valve stem a very little and the pound ceases, but also with the result of loss of power. Under these conditions I find face of valve dirty, evidently caused by loss of explosion on account of valve not seating properly. Have then shortened valve stem, allowing it to seat properly, and valve is bright and there is the power, but also the pound. Is not the seat of this trouble in the timing; that is, the exhaust valve not opening soon enough?  
W. C. B.

Kalamazoo, Mich.

Failure of the exhaust valve to open soon enough would be responsible for a great deal of back pressure on the piston, and this would doubtless manifest itself by a pounding noise. The exhaust valve should begin to open before the piston reaches the lower end of its downward course on the power stroke, so that it will be fully open at or just before the dead center is passed. The amount of this so-called lead varies with different designers, but you can ascertain about how much it is on your motor by checking up the action of the valve on the other cylinder. Look at the cam of the valve in question and see whether it is worn, or has become displaced. Wear of either the cam or the valve tappet would naturally tend to make the time of opening the valve later and as soon as this became sufficient to cause it to remain down on its seat beyond the point at which the cylinder should exhaust, the energy stored in the flywheel has to force the piston back against the cylinder full of gas and this would account for the noise, or pound, that you mention.

### ABOUT GRINDING CYLINDERS BY HAND.

Editor THE AUTOMOBILE:

[1,387].—Inclosed you will find a letter from E. Sparenberg, of Peru, Ind., in answer to my query published in "The Automobile" of May 7. I think this letter is of great value to some of your readers, and I would be pleased if you would publish it in your next issue:

"Mr. V. R. Lane:

"I was much interested in your query in "The Automobile" concerning compression. As I have had considerable experience in motor and auto building, probably I could help you out a little in your trouble. As is well known, the very slightest leakage reduces the power greatly. That is why manufacturers of high grade motors spend so much time and money to finish the cylinders so elaborately. In a motor of my own design and build, I did just what you are considering doing; that is, grinding the cylinder with an abrasive while it is in motion. Fairly good results were obtained in that manner. I then tried another method, which was far more satisfactory, and which I would do if I had your motor. First I took the cylinders, pistons, and connecting rods off and ground the cylinder out by hand by working the piston back and forth, with rings off. I used emery dust, and while working the piston kept turning it around continually. In this manner the cylinders were ground out perfectly, great care being taken not to grind too much. I then had new pistons and rings turned, which, by the way, is not very expensive, and fitted them very carefully. The rings should be doweled, the pin, of course, coming at the joint. The new pistons should fit tightly, that is, so you can just work them by hand, and plenty of oil should be fed until they are worn a little. I am talking from experience, not from theory, and hope this information will be useful to you."

Peru, Ind.

E. SPARENBERG.

"Letters Interesting and Instructive" have been of great value to me and, I presume, to many of your other readers.

West Liberty, Ia.

V. R. LANE.

### FOR AUTOISTS SEEKING PUNCTURE INSURANCE.

Editor THE AUTOMOBILE:

[1,388].—In regard to note from E. Eiseaman, No. 1,352, in regard to internal tire protectors, better advise him to try the Dow inner tube. I have tried the External tire protectors and, while they do all they claim, they detract from speed and make a car "loggy." I have gone on the principle that no matter what the financial cost, anything which would do away with the fear of puncture without interfering with speed, resiliency and responsiveness of the car, was cheap. The metal inside tire protectors have been tried by many and discarded as unsatisfactory. I have just tried the Dow inner tube long enough to feel safe with them and, while the first cost is excessive, the knowledge that you can drive a nail through your tire and tube if you want to and have it seal itself perfectly without the loss of air, is worth to me all it cost.

The tube itself is a very heavy one; with the tread double; between the two layers of rubber is a plastic material incorporated with feathers, which does the trick. The first time I went out with one I picked up a piece of board containing a nail which pierced the tire and tube, and with any other tube would have resulted in deflation and later repair. I pulled it out and have paid no further attention to it, and the tire is still hard. It seems to me to be the best device yet, and I therefore pass it along.

ELIOT GORTON, M.D.

Summit, N. J.

### AGREES WITH MR. KRARUP ON SPECIAL STEELS.

Editor THE AUTOMOBILE:

[1,389].—I have read with a great deal of interest Marius C. Krarup's comments on "Special Steels." For the last eight years I have been connected indirectly with the manufacture and operation of motor vehicles, especially commercial vehicles, and must say that my observations and experience tend to confirm all of his statements from No. 1 to No. 5. For commercial vehicles, whether taxicabs or heavy trucks, where vibration and road shocks are excessive, I should much prefer to see a low point carbon alloy steel, never over 30 point, used, and that the cross-section of the various parts, especially axles, steering knuckles and connections, should be large.

The parts as ordinarily designed may be large enough to withstand all ordinary shocks and vibrations for several months, but the time is sure to come when some shock is met with, a little greater than before, when any one of these parts will fail. A slight increase in cross-section or size of the parts mentioned will not increase the weight or first cost of the vehicle appreciably, but will be the best insurance the purchaser can have. The commercial vehicle has only to break down once and be towed in and remain out of commission for a day or so to more than offset any first cost that the above may entail.

Boston, Mass.

ALEX. CHURCHWARD.

## MASSACHUSETTS TO HAVE MILITARY-GUARDED ROAD RACE

**L**OWELL, Mass., May 25.—Since the announcement a fortnight ago that an automobile road race was to be held just outside this city on the Fourth of July, the "Merrimac Valley course," as the circuit has been christened, has been visited by

any trouble to a driver well acquainted with the course. From the double curve the smooth macadam roadway continues up the river bank with only one curve to the Tyngsboro bridge, where the upper turn is located.



Merrimac Valley Course, where the Steepest Climb Presents Itself.

large numbers of autists, including some of the prominent racing men of the country. And all who have driven over the roads that are to be used have come away well pleased and have expressed the opinion that the Lowell race should be one of the speediest and most exciting ever held in America, not even excepting the great international contests that have taken place in the vicinity of New York. The circuit is only ten miles long, and is to be covered twenty-five times to make the 250 miles of the race. On almost any course so many circuits would be extremely trying on the drivers, but the Merrimac Valley course is peculiar in that it consists of practically two straightaways with none but easy curves and a turn at either end. Lowell Automobile Club has charge of the contest, and the officers and committees are hard at work preparing for the race. Besides the valuable Butler Ames trophy, three cash prizes have been offered of \$500, \$250, and \$125 for the drivers finishing first, second and third respectively.

It has been decided to start the race on the boulevard, where there is a straightaway of considerably more than a mile. This situation will make it possible for the spectators in the stand to see the racers at full tilt, and the stretch offers opportunity for speed not equaled even by the famous Jericho turnpike. The scene of the greatest bursts of speed in past Vanderbilt Cup races. Some distance from the start the boulevard swings to the right with an easy curve and then to the left around a bend in the river. Then comes the first difficult place, a double curve opposite the Vesper Country Club. This curve will not cause

Here the course swings to the right and the cars will make a semicircle into the back stretch. This turn is in good condition for speed, but for the race it will be banked.

Immediately after entering the backstretch of Willow Grove avenue there is a long fifteen per cent. grade that has to be surmounted, and then a sharp pitch into a hollow and another climb, the steepest in the course. The road is straight and has a good surface, so these hills will supply only the needed variety from the level boulevard. Entering Varnum avenue there is a fine smooth roadway all the way back to the city. In lower Varnum avenue there is a car track, but

there is plenty of room on the sides, and the street will be closed during the race. At the lower turn there are to be banked corners, a cross street being taken for the purpose. This will bring the races into the lower end of the boulevard and give them time to straighten out and attain highest speed before reaching the grand stand.

There is ample room along the boulevard for parking spaces and for throngs of spectators, and the Lowell Club is planning



Two-mile Straightaway 50-foot Road Near Start.

to take care of a great crowd. The course will be patrolled by militiamen, and arrangements are being made to secure fifteen companies for the purpose, so that there will be ample protection for every foot of the course. This will be very necessary on the straightaway stretches near the start and finish, as the ground there is very flat and ample precautions will have to be taken to guard against the crowd spreading out over the road at these points. As a matter of fact, a very large part of the course is favorable to the crowding of spectators, and that this is realized is evident from the thoroughly businesslike precautions that the promoters of the race are taking to guard against interference from this source. The manner in which these measures are being carried out might well be patterned after elsewhere, as it is the intention of the promoters of the race to leave nothing undone that will tend to insure a clear course for the contestants and the absolute safety of the spectators.



Where the Long Grade Begins Just After Making the Upper Turn.

# HOW THE A. A. A. TOURING BOARD DOES ITS WORK

By T. J. SULLIVAN.

**B**UFFALO, May 25.—From the date of the quarterly meeting of the directors of the American Automobile Association, to be held here June 2, to arrange for the National Good Roads and Legislative Convention, to the departure of the caravan of cars on the reliability contest for the Glidden and Hower trophies, July 9, Buffalo expects to emphasize her present claim to the title of the "Capital of American Motordom." Thus far her claims to the distinction rest upon the circumstances that this is the abiding place of President William H. Hotchkiss, of Chairman Frank B. Hower of the Touring Board, and of Dai H. Lewis, secretary of the latter-named body and pathfinder of the reliability route, and that here is the headquarters of the Touring Board.

Not unknown to fame is the chairman. Many who took part in the Cleveland-Chicago-New York tour of last July recall with various feelings the shock they received when they attempted to handle the chairman of the Touring Board and bend him to their own ends. He looked quiet and pliable, but they found him a live wire. The thirty-five newspaper representatives, partially accustomed to having officials come to them on the jump when they crooked their finger, hardly knew what to do when Chairman Hower jumped on them. Finally a few of them decided that they would roast him. And they did. There were few who arrived in New York without a liberal brown from the sun and dust of the tour, but the chairman must have felt cooked through.

The offended scribes roasted him the first day from Cleveland to Toledo because the pace was too slow; the next day they roasted him because the pace from Toledo to South Bend was too fast. Because some contestants took muddy turns too fast with resultant disaster, the chairman had to stand the blame. Newspapers throughout the country were shrieking with the "suicide race" as a grateful relief from the former absorbing topic of "race suicide." When the chairman took the matter in hand and went ahead as pacemaker, the hypercritical correspondents hounded him for that. The pacemaker started a half-hour ahead each day, the contestants starting each a minute later thereafter, then tore madly over the landscape until they bumped the rear axles of the chairman's car and of one another, riding in a cloud by day and a pillar by night, and accumulating strata of dust on their features until they looked like an excursion of grain scoopers. And Chairman Hower was cursed for the dust, too.

"Why doesn't he go faster or get out of the way," raved the Hotspurs of the pens that two days before were filling columns with lurid descriptions of "The Race of Death."

But the "Napoleon" went on his uncompromising way. Other members of the touring committee insisted on having their way, and in every case where he yielded a mistake was rung up. Finally, he paid no attention to protest or "holler," but took absolute charge of the tour. And between their clamorings, the newspaper men noticed that Chairman Hower was making good. The tour, they admitted, was conducted without suspicion of graft, and every entrant received a square deal. And as the profession is basically fair and only occasionally hysterical,

it befell that by the time the tourists arrived in New York they voted unanimously that "Napoleon" Hower was a good fellow and that the tour the most successful on record. The "All's Well that Ends Well" came when he was appointed as the "Committee of One" to conduct this year's tour, with nearly universal approbation.

## What Is Being Done at Touring Board Headquarters.

But while Chairman Hower's work in connection with the annual tour is well known, few are aware of the other matters that keep him and five assistants busy every day in the year, aside from Sundays. The annual tour, heretofore known as the Glidden Tour, is a mere incident in the year's work. It is the traveling show conducted by the Touring Board to advertise the ability of touring cars and runabouts to travel any distance over American roads and to visit any Summer resort by seashore or on mountain with the maximum of enjoyment and the minimum of discomfort in traveling. It requires months of prepara-

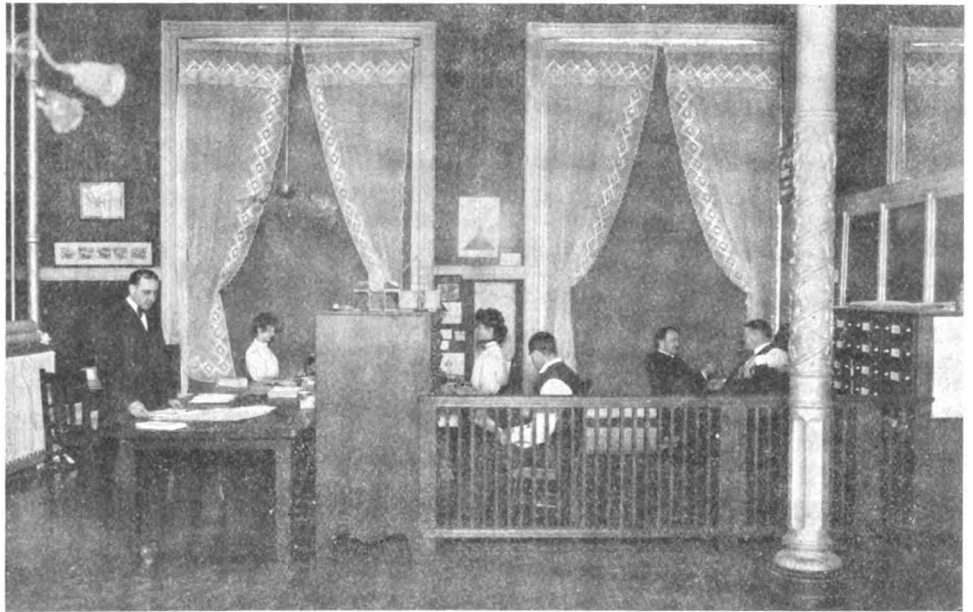

Headquarters and Staff of Chairman Hower in the A. C. of Buffalo.

tion and volumes of correspondence, but even its preparatory period is a mere chore in the day's routine under the sign "Office of the Touring Board, A. A. A.," which marks off the front part of the assembly room of the Automobile Club of Buffalo as the "Capital of Tourdom."

The larger work of the Touring Board arises in connection with the supplying of information to tourists all over the world. Every year, the destiny of the automobile as the chosen vehicle for touring is becoming more definitely fixed. As soon as the Winter is gone and roads become settled, the hegira of auto tourists begins. Southerners lead off by starting northward for the Niagara Frontier, the Lake region, and the seashore. Westerners follow, fleeing from the midland heat to the lakes, the seashore and the mountains. The Easterners swell the caravans from the big cities, traveling from one Summer resort to another.

The auto has superseded the railroad coach in these climatic migrations. No more the stuffiness and cinders of the railroad train, the dependence upon the mercenary Senegambian, the passage through cuts and tunnels and the grimy parts of towns. Instead, for people even of moderate means, the flight across the landscape in autos that glide as lightly as a cloud shadow



across a meadow; the scent of wayside flowers; the caresses of the flight-created breeze; the companionship of birds; the coolness and beauty of roads through forests; the entrance and departure from cities and towns by the most beautiful streets where the people live, instead of the backyards and gables seen from train windows. It is this increasing custom of touring that is piling up work for the Touring Board, and particularly for Hower, the "Burgomeister of Tours."

#### Aid for 165 A. A. A. Clubs Available.

The Touring Board is composed of secretaries chosen from the 165 automobile clubs affiliated with the A. A. A. and chairmen of the touring committees of these clubs. Say that Col. Pierre Toutant Beauregard of Memphis, Tenn., desires to travel from that city to Saratoga with his family, in his touring car. Probably he writes a letter to the secretary of the automobile club to which he belongs. In any event, the letter is forwarded to Chairman Hower and his assistants get busy. They are busy, anyway, for about 300 such letters are received daily. They resort to files arranged alphabetically where routes and route maps are stored away. Back to Memphis by return mail goes a fat envelope filled with the information which Col. Beauregard desires to know. He is conducted from city to city from Memphis to Saratoga. The furnishing of this information implies vast preliminary work. The board is in constant communication with all of the secretaries and touring committees of the 165 affiliated clubs, seeking information concerning routes. Clubs are encouraged to lay out touring routes to the nearest cities.

#### Information and Aid for Those Who Go Abroad.

Another useful function taken up by the Touring Board is the furnishing of information to tourists who wish to take their cars abroad. Representatives of the Touring Board in foreign countries are in constant communication with the Buffalo headquarters, furnishing the latest information obtainable in regard to customs charges, speed restrictions, chauffeurs' licenses, and routes, so that any member of a club affiliated with the A. A. A. or any individual member may start for Europe equipped with all essential information. Arrangements are also made for him whereby an express company will take charge of the shipping of

his car through all of the customs houses he may encounter between his departure and arrival home.

#### A. A. A. Clubs Are Placing Many Signboards.

Still another field of usefulness of the A. A. A. Touring Board is the promotion of signboards at crossroads all over the country. The Board has made arrangements with a firm of manufacturers to supply any number of signs at \$1 apiece. The planting of these signs in places where they will do the most good is urged upon the various affiliated clubs. Under the encouragement of the Touring Board, these signs are springing up all over the country. They give the distances between cities along prominent routes and trunk line roads, indicating the way by unerring arrows.

The registration of non-hold-up hotels has been begun this year, and is expected to be completed as far as the route of the reliability tour is concerned in time for publication. Every hotel-keeper in every city along the route has been written to, urging him to send in the regular rates of his hotel. The same system has been employed to secure a trustworthy list of official one-price garages. Ultimately, the list of hotels and garages will include every tourist route in the land.

#### A NOTABLE WESTCHESTER COUNTY TRAP.

During the greater part of 1907 Merritt Corners (in Westchester county, on the most-used road to and from Briarcliff Manor) was made more or less famous by the "trap" maintained there practically all of the season by the country justice. His persistence and methods made it appear practically certain that the financial returns were one of the objects of the "trap," to which a large number contributed unwillingly, especially on Sundays and holidays.

The "justice" is on hand again for 1908, with his "trap" in the same good working order it was during 1907, but with the exception that he has moved it a trifle to the south, near the well-known "S curve" at Echo Lake. This was evidently done to take unawares those who might be forewarned of the "trap" at Merritt Corners, and another reason for moving it down to this point was doubtless to "catch" a number who could not very well go around the curves at that point at "four miles an hour," which the justice seeks to enforce.

Within the past week one accident has occurred at this point, due to the fact that the constable stopped a car in the middle of the road, and would not allow the driver even to pull it to one side. This was clearly carrying matters too far, and when another automobile came up from the rear and ran into the stalled car (something that could hardly have been prevented under the circumstances, no matter how slowly one might be driving around the bad curves at that point), the owner of the car was thoroughly aroused. At the present time plans are formulating to sue the township for the damage done the car under these circumstances, and the result of the contest, which will be pursued with vigor, will be awaited with interest.

#### DIXIE IS ALSO ALIVE TO AUTO DOINGS.

Automobiling is gaining in the South, and these items, culled from Southern newspapers, tell the story of progress.

The automobile from West Point passed through our community Sunday, causing several horses to get badly frightened. No one was hurt.—"Opelika (Ala.) Post."

An automobile line, with hourly trips between Jacksonville and Anniston, is being discussed at both places.—"Montgomery (Ala.) Advertiser."

Dr. Payne has an automobile now. We expect to hear of several more in the near future.—"Anderson (S. C.) Intelligencer."

The use of automobiles is becoming more and more general throughout Tennessee. This fact is shown by the number of automobile licenses which are being granted in the office of Secretary of State Morton. Recently these licenses have been granted at the rate of three or more each day. Since January 1, 1908, a total of 83 licenses have been issued. This does not include between fifteen and twenty transfers which have been recorded.—"Nashville (Tenn.) Banner."



Posting Entries for the Annual Tour of the A. A. A. and Contests for Gildden and Hower Trophies.

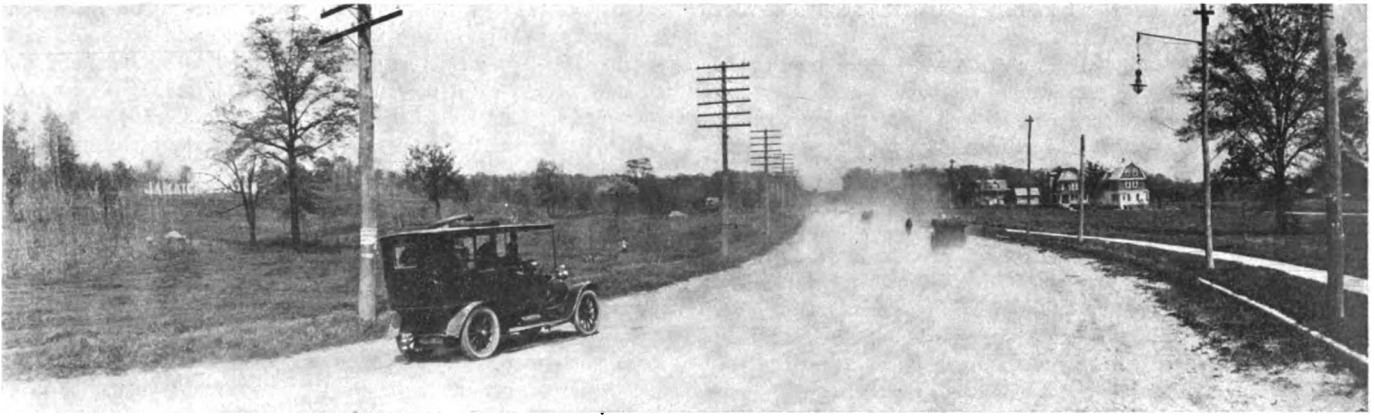

Well-traveled Long Island Road, Included in Greater New York, Illustrating Dust Problem Unrelieved.

## THE ONE QUESTION OF THE DAY: THE ROAD PROBLEM

By SIR JOHN H. A. MACDONALD, K.C.B., IN "THE MOTOR," OF LONDON.

FOR fifty years the road—after the advent of railways—was looked upon as a more or less negligible quantity in national affairs. One could ride or drive for a whole day without meeting one vehicle in every half mile, and, on some roads, on which at the beginning of the nineteenth century there was a considerable amount of traffic, not a single carriage of any kind would pass in an hour. To keep up roads in good condition for such sparse traffic would have been waste of labor and of money. During the latter half of the century all the roads were suffered to deteriorate. People grumbled, but that was all. There was an instinctive feeling that to seriously ask for anything better meant an increase of tax rates without any corresponding practical gain. It was in this condition of things that our highways were found when the advent of power traction revived the road as a means of long-distance communication. They were unfit for use as roads in the sense of being really ways for traffic.

Such having been the state of things, it is not to be wondered at when the roads began to be used once more and a hundred vehicles passed in a day where five passed formerly, that the wear and tear on these villainously ill-constructed and ill-tended roads should have caused much breaking up of surfaces, and called for more outlay to put and keep in efficient order. Of course, the blame was laid on the motor car. It was declared that it injured the roads more than did the horse traffic. This was quite untrue. The advent of the motor carriage added largely to the number of vehicles upon the road, and it was this, combined with the fact that the roads were already bad and incapable of carrying horse traffic without injury, which caused the outcry. **But it was not realized that if horse traffic had suddenly been increased by several hundred per cent. on the ill-laid and ill-tended roads the destructive effect would have been infinitely greater.** This was not appreciated at first by Roads Boards and District Councils.

The cry was that power traction must be prohibited on the existing roads. On every hand one met with the suggestion that the motorist should be ordered off the roads and must have roads made for himself and not put his wheels on those already existing. It appeared to be the idea of those who had not taken up the new mode of road transit that the traffic should be regulated to suit the roads that were provided, however bad they might be, rather than that when there was a development of traffic the road should be kept up so as to carry it. The things that were said put one in mind of the story of the mother who made it a matter of complaint against her child that when she had provided—as she thought—suitable clothes, it had the impudence to grow out of them, and that if it chose to get so big as that it should find its own clothes.

The time has come when the motorist, in his own interest—

which is, in the end, the interest of the whole community—must put forth every energy for obtaining improvement of the roads. He must din it into the ears of those who are dull of hearing on the matter that in improvement of the roads is to be found relief for present discomfort, convenience for pleasure and for commerce, economy in locomotion expense and great increase to the national wealth. Those who will not hear must be made to hear this; those who will not see what is before their eyes must be made to see.

There is no one now, who is not a fanatic or a lunatic in hatred of power traction, who does not know and confess, however reluctantly, that **the power vehicle is a permanency on our roads**, and that road traffic is becoming as important as it used to be in the days of the mailcoach and the carrier's cart. And, as the population is so enormously increased since those days, the actual number of vehicles put upon the road will be very much greater than it has ever been before. The roads which were narrowed by converting their sides into green pastures for cottagers' cattle and hay-making grounds for the food of the road authorities' horses, must once more be widened to the extent necessary for safety and convenience. The most scientific system of road making must be adopted and efficiently carried out.

Locomotion will always be cheaper on good roads than on bad. For it will be faster and less injurious to the power used for haulage and to the vehicles. This is well illustrated by what happened in the early days, when the coach began to supersede the horse as the traveler's means of conveyance. Two instances will suffice. The first coach service between London and Dover, a distance of a little more than eighty miles, took three days to make the journey. The first coach service in Scotland, between Edinburgh and Glasgow, required two days to accomplish the distance, although it was only forty-two miles. Does anyone doubt that the improvement of the roads which made it possible for these journeys and other similar journeys to be completed in half the time taken at first did not constitute an addition to the wealth-producing power of the country, diminishing the cost of wear and tear of animals and carriages, and the expense of the journeys to travelers, and facilitating the rapid transaction of business by intercommunication between one place and another being accelerated.

Everyone who is interested in motor traction, whether for pleasure or social purposes, whether for business facility or goods transit, or has the still more direct interest of being engaged in the manufacture of or dealing in power vehicles for whatever purpose, will act wisely if he devotes some energy to enforcing upon our authorities, legislative or administrative, **the necessity of the present great revival of road use being encouraged** by a wise and courageous policy of improving the

roads, as a certain means of adding to the financial and social prosperity of the nation.

Let it be borne in mind that we are a race which is not easily moved out of a groove into which we have been led or have fallen. The British temperament is well expressed in the oft-repeated saying that, "what was good enough for my grandfather is good enough for me." When the three-days' coach service was organized between London and Dover it was denounced in the public prints as an uncalled-for innovation, and it was declared emphatically that no such rapid, rushing service (?) was required. In the same way, when the first hackney vehicle was put upon the streets of London, running about six or seven miles an hour, it was inveighed against by people, who maintained that no citizen's life would be safe if such carriage were allowed to ply at these dangerous speeds in the streets.

Well, a great deal has happened since then, and a great deal more is going to happen now. The establishment of what was called fast (?) traffic in those early days led up to the study of the road, which had its results in the great achievements of Macadam, who, be it remembered, began his work as an amateur

enthusiast. The establishment of power traction on roads—and it is established permanently and forever—will have the same result. But that it may be as little delayed as possible, and that all may benefit by it now, and not later, it should be taken up vigorously. This has been done in measure already, but it has only been one of the many things engaging the attention of the best mechanical engineers.

The time has come when the road is the one question of the day. **The motor vehicle is now a thoroughly practical instrument for locomotion, whether for passenger or goods traffic.** That its efficiency may not be handicapped by the badness of roads is the question of the hour—the one great question which it is the duty of all motor organizations and all motorists to press upon public attention and upon which it is a duty to give the authorities no rest until the work of road improvement is taken up in a thorough manner, and pushed on vigorously. That good roads can be made at a reasonable expenditure, when initial cost and subsequent maintenance are put together, is certain. The only thing that is uncertain is how long it will take to overcome the visinertia of officialdom.

## THE PRESERVATION OF IMPROVED ROADS IN NEW JERSEY

BY ROBERT A. MEEKER, NEW JERSEY STATE SUPERVISOR OF ROADS, IN ANNUAL REPORT.

OUR good roads are becoming so worn by the continually increasing automobile traffic that the problem of maintaining them in their fine condition is one that confronts us constantly. What shall we do? How shall we do it? Is there any known substance that will withstand the constant attrition of rapidly revolving auto tires? If not, is there any remedy that will reduce the cost of maintenance and prolong the life of our hard roads? Many answers have been made to these questions, many methods have been suggested and tried, many materials have been tested, and still the problem is not solved. Extremists on both sides have come forward and argued loud and long. The aggrieved property owners propose that the roads be allowed to wear down to the large stone, when they will be so rough that the autoist will avoid them. Then, say they, the dust nuisance will be abated, and the highways will be safe and convenient for pedestrian and horseman.

The enthusiastic automobilist says the roads should be kept in constant and perfect repair; that no ruts should be allowed to form, and that no holes large enough to hold a pail of water should ever be permitted on the surface. "True," replies the resident taxpayer, "but who is going to pay the bills in order that he may enjoy the pleasure of having his lungs, lawn and house filled with stone dust?" The autoist replies, "We pay a license fee and an occasional fine, which help to maintain the roads." Mr. Taxpayer scornfully answers, "Yes, about one-eighth of the cost." Thus the merry war goes on, and we are no nearer the solution of this vexed problem than when it first presented itself.

The conservatives of both sides feel that something should be

done, and that there is something of truth in the contentions of each side, hence have proposed many methods of relief. The first and most natural is that of sprinkling with water. This lays the dust and cements the surface, but must be repeated so often that it is too expensive, hence many other substances have been tried, with varying degrees of success. Among these may be mentioned crude oil, coal tar, asphaltum oil, applied hot or in solution with ammonia, and compounds having the power of absorbing the suspended moisture of the atmosphere, the most common of which last is salt, but none have thus far proven entirely satisfactory. Either they are too costly or the results, if good, are only transient.

A careful study of the problem on the New Jersey roads leads us to the conclusion that there is only one remedy; that is, to distribute the traffic. To this end it will be necessary to build practically parallel roads between our principal cities and resorts, at the same time widening our old roads, thus dividing and distributing the travel, and likewise the wear.

We have some such routes now. By building a few short links here and there we can increase their number, and if at the same time the old roads are widened, the travel will be divided and distributed to such an extent that the wear will be materially diminished. This proposition is entirely feasible, as a glance at our road will quickly show.

The construction of these short stretches will not only distribute and consequently reduce the wear, but will also open up new territory to development, and thus enhance property values, as well as promote the comfort of all the people, whether they live beside or travel over our improved roads.

## SPOKANE MOTOR CLUB INAUGURATES A FARMERS' DAY

SPOKANE, WASH., May 22.—What appears to be the most progressive move in the good roads campaign has been originated by the Spokane Motor Club, and will be carried into effect as soon as the necessary preparations can be made. Members of the club and other autoists interested in the movement are to assemble with their cars at a given rendezvous on the date set, the farmers for miles round having been previously invited to do likewise. Each car will be given over to the transportation of a farmer and his family from the central gathering point, and the farmer will be given an opportunity of judging of the condition of roads traveled over from the autoist's standpoint.

The real object of the "farmers' day" is to destroy the last remaining vestige of prejudice against the automobile. The autoists will meet the agriculturists more than half way, and will make the most of the opportunity thus presented, to state their case to the farmer in a way that the latter can appreciate as he will be in a position to see things as they are viewed by the autoist. The Northwest Automobile Company, Franklin representatives at Spokane, have been largely instrumental in fostering the idea of a "farmers' day."

It is hoped that the movement thus inaugurated will be taken up by automobile clubs throughout the country.

# AUTO ENTHUSIASM BOOMING IN SOUTHWEST

By F. S. SLY, TRAVELING CORRESPONDENT FOR "THE AUTOMOBILE."

**F**ORT WORTH, TEX.—This is my last stop in Texas, and it is easy to see that business is in a good condition here, even without the dealers' statement to that effect.

There are about 130 cars in the city, but as yet no club has been organized. The roads are simply of dirt formation, but are good during the dry weather, though not so favorable after it has been raining for some time. At the present time, an improved form of gravel road is under construction to connect this city with Dallas.

There are four garages, run by Hamilton Clough, who handles the Stoddard-Dayton, Jackson, and Jewell; Thomas Abbott, who has the Maxwell; H. H. Lewis, representing the Buick, and F. J. Boas, who does not do any agency business.

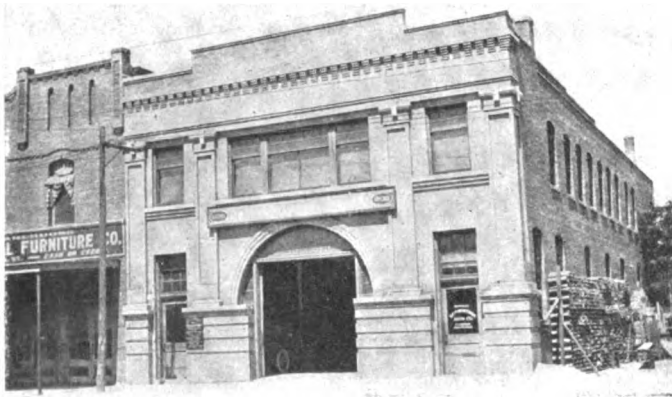

A Typical Garage Building In Ft. Worth, Texas.

From what I have seen of Texas, it is easy to appreciate that it is a State that will ultimately come to be one of the largest users of automobiles in the country, population considered. It is truly a State of magnificent distances, and the average Easterner who has heard the same expression used in connection with more or less familiar things at home, can form no conception of what it means out here.

### Oklahoma Citizens Are Strong Buyers.

**OKLAHOMA CITY, OKLA.**—Here is a boom center in automobiling without a doubt, as none of the cities that I have been in since striking this part of the country has had half as favorable report to make. It is reported that the Oklahoma Motor Car Company has contracted for no less than 200 of the small four-cylinder Fords and 50 of the six-cylinder type.

A very large part of this firm's business is with the farmers, to whom a great many of the small cars are sold. It can boast of one of the largest and best equipped salesrooms and garages that I have seen since leaving New York City.

There are now about 250 cars in use in Oklahoma City, and they are being added to at the rate of fully 30 a month, or practically one a day, from which you can judge of the extent of the autoing enthusiasm here.

In spite of this, however, the town cannot as yet boast of a club. The roads through the entire territory are nothing but the old wagon trails and are in exactly the condition that the wagons left them, but they are quite passable in dry weather, even at that. A few of them have been "worked," but so far as I can learn there has been little or no actual road building, as we know it in the East.

In addition to the Oklahoma Motor Car Company, which handles the Ford, Rambler, and Pope-Waverley electrics, there is the Severn Auto Company, representing the Cadillac; Fritz Brothers, the Reo and Premier; Alko Garage, handling the

Pope-Toledo; C. F. Elerick, the Tourist, and the John Deer Plow Company, the Moline. Every one of these concerns maintains a garage, beside which there is the Jeffreys Auto Company, which also runs a garage but does not sell any new cars.

### Little Rock, Ark., Is Progressing Well.

**LITTLE ROCK, ARK.**—Although there are about 65 cars in use here, beside a flourishing club of 25 members, of which Moorehead Wright is president; Irving S. Hirsch, secretary, and Perry Stiff, treasurer, there is but one concern in the automobile business. This is the Little Rock Auto Company, which handles the Franklin and the Buick and runs the only garage. Mr. Ladd, the president of this company, reports that business is very much better than it was last year at this time.

The club has not been organized long enough as yet to have accomplished much, but expects to do a great deal during the coming summer toward arousing auto enthusiasm. Among other events, a run is planned to Memphis, and will be held some time this month. There are several good roads leading out of the city, and the ordinary country roads are in very good condition in dry weather, although they are quite the reverse when it is wet.

### Arkansans Are Enthusiastic Autoists.

**FORT SMITH, ARK.**—But eighteen months ago this town could boast of exactly two automobiles and half the population had a habit of coming out to "rubber" every time one of them went by, while their simultaneous appearance on the street in one place drew a crowd that all but impeded their progress. Now



One of Oklahoma's Representative Business Houses.

there are not only 42 cars owned here, but every owner, as well as the dealers, belongs to the Ft. Smith Auto Club, a progressive step in the organization line that might well be patterned after by many cities having vastly more cars in use. John Vaile is president of the local club; George Lyman, vice-president, and Fred Reutzel, secretary and treasurer.

The club is becoming a great power in the good roads movement throughout the State, and has even repaired several short stretches of bad road at its own expense. There are a number of macadamized roads running out of the city in different directions.

The Ft. Smith Auto & Supply Company has just completed a modern garage and salesroom of which many a larger city could well be proud. This concern runs the only garage here, and in addition handles the Franklin and the Buick, while W. T. Blocker represents the Ford, and Gus Boehmer handles the Reo. For the past few months business is reported as having been a little backward, but the prospects for the season are good.



## EFFECTIVE TIRE PROTECTORS THAT ARE EASILY MADE

By A. D. HARD, M.D., MARSHALL, MINN.

THE rough and rutty roads of the West call for more than ordinary provisions against wear on pneumatic tires, especially on the sides where the hard baked ground forming the walls of deep ruts tears the rubber from the fabric and then quickly prepares the casing for a first-class blowout. I have tried almost everything which has been suggested to enable me to disregard road conditions and still have a little rubber left on my rims. I now use the device which I am about to describe, because it is far ahead of anything which can be purchased for the purpose where effective service and small cost are concerned. I have briefly spoken of this home-made tire protector before in THE AUTOMOBILE, and, as a result, have had so many letters inquiring how it is made that I am compelled to answer them all with this one reply.

My automobile has clincher tires, 30 by 3½ inches, and this description applies to that size, though any sized tire may be used by varying the measurements to suit. My protector is made of casings which have been discarded because of rim cuts, blowouts

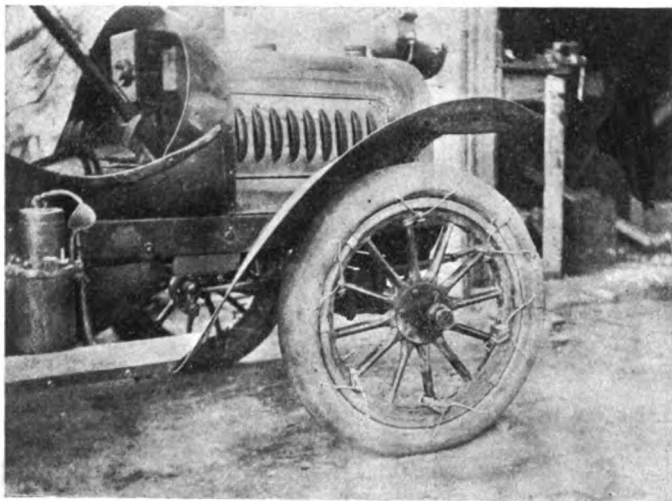

How the Home-made Tire Protector is Fastened.

or other injury, not being completely worn out. The old casing is cut in two, cross section, choosing an injured part if there be one, so that it may be eliminated by cutting off the injured part from one end. The beads which fit into the flanges of the rim are then cut off with a stout knife, and the protector is placed around the tire that it is intended to protect. If the old casing has not been shortened to get rid of some bad portion, the protector will lack four inches of surrounding the wheel, which may be filled in by a small section of another old casing.

This short piece may be fastened securely by using several wire belt links, with the points on the outside, to unite it to the ends of the old casing. Opposite every other spoke a mark should be made on the sides of the old casing, beginning with the spoke which should be in the middle of the small section. Three inches on either side of these marks, and about ¼-inch in from the margin, holes should be made through the walls of the old casing with a ¼-inch punch, such as is used by harnessmakers for heavy leather. Pieces of number 9 galvanized iron wire 12 inches long are bent like a wide-open V, and hooks one and one-half inch long bent on the ends, the hooks at right angles to the plane of the V. These wires are hooked through the holes in the sides of the casing with the points outward, and the ends bent down and around the base wire. This will give six retaining wire loops on each side, spaced to come opposite each other, and in line with the six alternate spokes of the wheel.

Half-inch wide rawhide straps fifteen inches long are then used to hold the protector on, each strap passing through the

V-shaped wire loops on either side of the wheel, and on both sides of the spoke. These six straps are drawn moderately tight before the tire is pumped up, and when inflated the protector should fit quite snugly all around. The wires on the sides serve not only to hold the protector in place, but they protect the shoe from side wear in ruts. The tread will not wear off as fast as the tread of an ordinary tire, because it is not under similar tension, the surface yielding somewhat to any tearing action of road impediments, instead of being gouged out. Dust will get into the space between the tire and protector, but it will quickly work out at the point where the short section is spliced in, and will do no harm. If these protectors are placed only on the front wheels they still will save the wear on the rear tires almost as much as though they were also similarly covered. This is due to the fact that the protector increases the diameter of the front tires about three-fourths of an inch, and this increase in size serves to make a path for the rear wheel which is larger than the rear wheel tires.

If placed on the rear wheels it increases the speed of the car by increasing the diameter of the drive wheels. Nearly all injury to tires is guarded against by this form of protector, and the tire may be pumped up much tighter than ordinarily, yet not decrease the resiliency, because of the extra amount of yielding rubber on the tread. Cuts and surface injuries are taken by the cheap protector, saving the expensive tire. Running on a deflated tire thus protected does but little harm, as the large amount of rubber between the rim and the ground obviates bruising of the tire and rim cutting.

Very few nails are long enough to go through both protector and tire to produce punctures, and the fabric of the tire never becomes exposed by wear to the destructive action of water or oil. Tires do not heat in use, because the large amount of heat conducting material in contact with the tire quickly dissipates the heat. If placed over a worn and weakened casing the tendency to blow-outs and other injuries is obviated, and the old casing can be trusted to wear about as long as a new one would without the protector. The cost of these protectors is almost nothing. If the old casings are valued at seven cents per pound as old rubber they are worth about one dollar each. The labor and straps will not cost to exceed a dollar and a half for each protector, making them cost only five dollars a pair, and they are better than any leather tread ever made at any price. The enclosed photograph shows how the protector looks on the wheel, and will serve to more fully explain my plan of construction.

### AKRON'S TIRE FACTORIES IN FULL BLAST.

AKRON, O., May 25.—There is no panic among tire manufacturers at present. Never before were tires ever put out in such quantities in this city as at present. What surprises the manufacturers at present is the permanency of the movement. A month or more ago there was noticed a sudden increase in orders for automobile tires, and the manufacturers replaced their full force of tiremakers which almost entirely had been laid off during the winter months, when trade was at a standstill. The little spurt, as manufacturers chose to call it, was attributed to the re-equipping of 1907 machines by owners and not to any demand for 1908 cars, and it was expected that the rush would be soon over.

But there has been no let-up as yet, and at present the Goodrich, Diamond, Goodyear, Firestone and other local companies are working their fullest capacity to supply the demand. An official of the Goodrich company said this week: "We are far behind our orders and cannot begin to manufacture fast enough to keep up with the trade. The rush of orders has grown into an avalanche, and we believe that the activity will continue. The local tire plants began running night shifts a month ago."

THE other day in Paris four blasé individuals were sitting, in the mid-afternoon, on the terrace of a café in the Boulevard Montmartre, just where the Rue Montmartre crosses that busy thoroughfare. One of these individuals suggested a race to the Café de la Paix, half a kilometer away, down hill and along the Boulevard des Italiens, through that always dense throng of busy folk and idlers, and across the Place de l'Opera, as congested a public square as one finds anywhere in the world, save at the entrance to Brooklyn bridge in New York City during the rush hours.

Paris street traffic is commonly supposed to be entirely unregulated, and the Englishman, used to the admirably controlled traffic of London streets, protests loudly, if unintelligibly, each time he is nearly run down by the careering Paris *cocher* and his *sapin*. All is not lawlessness, however, the Paris *agent de police* and his white baton held in air is now a common, if unliked figure at the corners of many crowded Paris streets and as far as his services go they are fairly efficient, though not yet up to the London standard.

New traffic regulations had just gone into effect and the four confident Parisians each chose for himself the means of making the *étape* between Paris' two popular cafés. One chose an ordinary cab, the *voiture à cheval* or *sapin* indigenous to Paris; another an autotaximeter, as being more speedy after it once got to moving; the third elected to go by autobus, and the fourth simply started out to walk.

The distance was not great to be sure, but the conditions were sufficiently arduous to make the affair interesting though the stakes were simply *aperitifs*, the Frenchman's substitute for the "five o'clock" at the Café de la Paix, opposite the French Académie Nationale de Musique, which all the world knows as "The Opera."

RESULTS: The autobus and the man on foot arrived in a dead heat; the walker simply wormed his way in and out of the slow-moving traffic and finally arrived; the autobus which carried the other winner did practically the same thing, though the chauffeur was put on his mettle by an ample *pourboire*; and by a fortunate position in the slow-moving, wriggling line of traffic succeeded in blocking the auto-taxi on two or three occasions, and so crossed the Place de l'Opera and deposited the winner

## AN ORIGINAL RACE



at the same time and place as the man on foot arrived. Time, nine minutes, not too fast for safety, one thinks; but then there are those exceedingly difficult conditions to take into

consideration. The cab or *fiacre* was hopelessly behind, and only arrived at the end of thirteen minutes, having been blocked en route here and there on the roadway by the traffic.

The auto-taxi arrived in eleven minutes, two minutes after the autobus, and two minutes before the *fiacre*.

The autobus met the following obstructions en route, all of which it passed magnificently, handled intelligently as it was by its *mécanicien*—the Paris omnibus company has *mécaniciens* in charge of its autobuses, not merely chauffeurs. Perhaps that's why they are so well handled.

The autobus had stopped at the corner of the Rue Montmartre, and our lucky concurrent mounted the back platform just as the *mécanicien* let in the clutch and swung the vast rattling omnibus out into a twenty-five-foot open space that his eagle eye had chanced upon just at that moment.

Just beyond there was a horrible tangle, which, however, straightened itself out automatically with but a moment of time lost. At the Rue Richelieu came the second stop, but they were almost at once en route again, at a speed of certainly not more than four kilometers an hour, a long line of cabs, carts and omnibuses streaming along in Indian file. Opposite the Credit Lyonnais, as luck would have it, came a chance at last to get on "top speed." The gears were changed with a crash, and off the autobus went—for perhaps 50 meters. At the Rue Chaussée d'Antin a complete stop. Then making way again, another stop just before reaching the Place de l'Opera, the simple white baton of a Paris policeman barring the way.

Two minutes' wait, then a rush across to the Café de la Paix on the opposite side of the Place. "Stoppe!" said the intrepid voyager to the conductor as he prepared to descend. But there on the pavement beside him was the man on foot.

The problem would seem to solve itself thus: that all automobile traffic—automobiles, autobuses, and auto-taxis—should have special thoroughfares set apart for their use. Then, and then only, will the new locomotion become, in the cities, really efficient. Perhaps some day this millennium will arrive, before familiar on the Acme stock cars during the past few years.

## CONCERNING THE ACME RACER FOR VANDERBILT CUP RACE

THERE will be at least one six-cylinder car entered for the Vanderbilt Cup race, advices from the builders of the Acme being to the effect that their entry will be of this type. The entry of a multi-cylinder car in a classic road event is nothing startlingly novel, sixes and even an "eight," having figured in the elimination trials for the Vanderbilt years ago, but the entry of a six-cylinder at this time is particularly interesting, owing to the great amount of discussion that has been going on regarding the various advantages embodied in this type, as compared with cars provided with the smaller four-cylinder engine.

Apart from the fact that the motor for the Acme entry is to be of the six-cylinder type, and that its dimensions will be 5 inches "square," i.e., bore and stroke the same, nothing is as yet forthcoming regarding its design or construction, although it is to be presumed that this will be something differing from the usual Acme standards as represented by the touring cars of the latter make, although it is stated that in all other respects the Acme Vanderbilt racer will closely adhere to the construction

familiar on the Acme stock cars during the past few years.

An interesting question has arisen over the fact that some of the material that will go into this racing car is of foreign origin, much of the steel being the Krupp chrome nickel, which is specified for such parts as the shafts and gears of the change speed gear set. This is the material used by the makers in the building of their stock cars, but in view of the fact that the rules governing the race specify that racing cars must be constructed in their entirety in the country which they are entered to represent, it was thought necessary to obtain a special ruling on this point in order to definitely settle the question thus raised. However, it will be noted that the rules only specify that the construction must be carried out entirely in the country of the car's origin, and that they are silent when it comes to the question of the origin of the materials. Therefore, there is not likely to be any difficulty so far as this is concerned. Good progress has been made in the building of the car and it is expected that it will be ready for its first road trials at an early date so as to have plenty of time for tuning up.

## AERONAUT GLIDDEN AFTER LICENSE.

PARIS, May 22.—Both Delagrang and Farman have temporarily abandoned the Issy-les-Molineaux ground, and the vast military field is as deserted as ever it was before the advent of aeronauts. Leon Delagrang has shipped his Voisin apparatus to Rome, and has left, together with one of the Voisin brothers and a staff of mechanics, to attempt a fifteen-minute flight for an \$8,000 prize, offered by the Turin Association. Farman, who has been searching for a new training ground near Ghent, in Belgium, will doubtless follow his rival, and attempt to snatch from him the time record in Italy. Later he will make attempts on the open ground at Ghent, first with his present machine, and later with the Flying Fish that Voisin is now completing and that Renault is fitting with an eight-cylinder air-cooled engine.

America is at present actively represented at the Aero Club of France Park on the Saint-Cloud ground by Tourist Glidden and Aeronaut McCoy. The latest ascent of the two Americans was a trip from the Saint-Cloud ground to Villeneuve St. George to the South of Paris. Mr. Glidden intends to get his diploma as a pilot of the Aero Club of France before returning to the States.

## RAIN CAUSES ATLANTA RUN POSTPONEMENT.

ATLANTA, GA., May 23.—Owing to the constant rains that have prevailed for the past three weeks, the Atlanta-Macon endurance contest promoted by the *Atlanta Journal*, has been postponed for three weeks or more, being set for some time in June. The deferred date has not been definitely decided and will depend upon road conditions as the latter are what caused the postponement. The long continued wet weather has been responsible for putting the roads in very poor condition and it is generally considered that it will take some time for them to become fit to run the event on.

The committee appointed to fix the distance table which will form the basis for the official running schedule, went over the course recently in Professor J. H. Smith's Pope-Hartford. Professor Smith is chairman of the committee and drove his fellow members over the course. They are Dr. Thomas P. Hinman, Charles Elyea and John E. Smith. The total distance one way between Atlanta and Macon is 95.3 miles, and it is anticipated that controls will be established at Griffin, 39.9 miles, and Barnesville, 56.4 miles, in addition to those at the start and turning point.

## WILL BE GOOD SPORT AT DELAWARE'S GAP.

PHILADELPHIA, May 23.—The *Public Ledger's* four-day tournament in the Poconos promises to be even more successful than its projectors had hoped for. That portion of the local automobile contingent that is always going round with a chip on its shoulder has become interested, and June 24, 25, 26, and 27 will in all likelihood witness an exodus to the Monroe county mountains. Louis J. Bergdoll, the local amateur crack, ran up to Stroudsburg last week to size up the possibilities of the coming tournament. He found the hill at the Gap all that the managers of the tournament said it was—a course that would demonstrate the merits of the best cars and drivers. He also pronounced the rise at Canadensis an ideal course for a hill climb "on the high," and it has been decided to give drivers in the open classes an opportunity to try their cars on this hill for separate trophies.

The routes for the double-header endurance run on the first day, June 24, from New York and Philadelphia, have been selected. From the metropolis the route to Stroudsburg will be via Tarrytown, Middletown, Port Jervis, Milford, and Bushville. From Philadelphia the contestants will journey via Doylestown, Easton, Portland and the Delaware Water Gap, thus avoiding the necessity of going through the State of New Jersey with its prohibitive license laws. The route around the anti-automobile State is much more picturesque.

## THE AUTOMOBILE CALENDAR.

### AMERICAN.

#### Shows and Meetings.

- June 25-27.....—Detroit, Third Annual Summer Meeting of Society of Automobile Engineers.  
 Dec. 31-Jan. 7.....—New York City, Grand Central Palace, Ninth Annual Automobile Show, conducted by the American Motor Car Manufacturers' Association, with Exhibits by the Importers' Automobile Salon, Inc., Alfred Reeves, general manager, 29 West 42d St.  
 January, 1909.....—New York City, Madison Square Garden, Ninth Annual National Show of the Association of Licensed Automobile Manufacturers. (Exact date to be announced.)  
 February, 1909.....—Chicago, Coliseum and First Regiment Armory, Eighth Annual National Exhibition, National Association of Automobile Manufacturers. (Exact date to be announced.)

#### Race Meets, Hill Climbs, Etc.

- May 30.....—Boston, Readville Track, Race Meet. Bay State Automobile Association.  
 May 29-30.....—Minneapolis, Minn., 300-mile Endurance Run, Minneapolis Automobile Club.  
 May 30.....—Bridgeport, Conn., Sport Hill Climb, Bridgeport Automobile Club.  
 May 30.....—Wilkes-Barre, Pa., Giant's Despair Hill Climb, Automobile Club of Wilkes-Barre.  
 May 30.....—San Francisco, Endurance Run under the auspices of the Automobile Dealers Association.  
 June 5.....—Jamaica, L. I., Straightaway Time Trials, Long Island Subway Celebration Committee, Assisted by Long Island Automobile Club.  
 June 6.....—Worcester, Mass., Dead Horse Hill Climb, Worcester Automobile Club.  
 June 24-27.....—Chicago, 1,200-mile Reliability Run, Chicago Motor Club.  
 July 4.....—Lowell, Mass., 250-mile Road Race, Lowell Automobile Club.  
 July 4.....—Wildwood-by-the-Sea, N. J., Annual Speed Tournament, Motor Club of Wildwood.  
 July 7-8.....—Buffalo, N. Y., National Convention of the American Automobile Association.  
 July 9.....—Buffalo, N. Y., Start of the Fifth Annual A. A. A. Reliability Touring Contest.  
 Sept. 5-9.....—San Francisco-Los Angeles Reliability Run, Automobile Dealers' Association of San Francisco.  
 Sept. 11.....—Chicago, Annual Economy Run, Chicago Motor Club.

### FOREIGN.

#### Shows.

- May 17-June 2.....—Moscow, Russia, International Automobile Exposition, Automobile Club of Moscow.  
 December.....—Paris, Eleventh Annual Salon de l'Automobile, Grand Palais, Automobile Club of France.

#### Race Meets, Hill Climbs, Etc.

- May 1-31.....—Automobile Taxicab Competition, France, Automobile Club of France.  
 May 31.....—Russia, St. Petersburg to Moscow Race.  
 June 1-18.....—Reliability Trials for Pleasure Cars, Automobile Club of Great Britain.  
 June 14.....—Mount Cenis Hill Climb, for Voiturettes.  
 June 9-17.....—Touring Competition for the Prince Henry of Prussia Prize, Germany, Imperial A. C.  
 June 15-19.....—Scotland, Scottish Reliability Trials.  
 July 6.....—Voiturette Grand Prix, Dieppe Circuit (Automobile Club of France).  
 July 7.....—Grand Prix of Automobile Club of France, Dieppe Circuit.  
 July 13-17.....—Ostend, Belgium, International Race Week, Automobile Club of Ostend.  
 Aug. 12.....—Ardennes Circuit Races and Coupe de Liedekerke, Automobile Club of Belgium.  
 Aug.....—France, Coupe de la Presse, Automobile Club of France. (Exact date to be announced.)  
 Aug. 29-30.....—France, Mont Ventoux Hill Climb, Vaucluisien Automobile Club.  
 Sept. 1-8.....—French Voiturette Contest, Auspices "L'Auto."  
 Sept. 6.....—Bologne, Italy, Florio Cup Race, Automobile Club of Bologne.  
 Oct. 11.....—Berlin, Germany, Gordon Bennett Balloon Race, Aeronautical Club of Berlin.

## SICILIAN WINNER TO COMPETE IN "LITTLE" GRAND PRIX

**P**ALERMO, SICILY, May 15.—With a little one-lunger measuring but 3.9 inches bore, an average speed of 28.5 miles an hour has been accomplished in Europe's first road race of the season, over 186 miles of the most tortuous, precipitous, and mountainous road of this mountainous country. Giuppone, cyclist and motor-cyclist, is the man who has won the Sicilian vioturette race, his little Lion-Peugeot, which led him to victory having the honor of beating the heavy car record established two years ago by Cagno.

There were eleven starters lined up in Indian file opposite the splendidly decorated stands at Bonformello at 7 A. M. of Sunday, May 10, the head of the line being held by Naudin on a Sizaire-Naudin, a position which was given him because of his victory last year.

Mechanically France only was represented in the race, the three firms engaged being Lion-Peugeot, Sizaire-Naudin, and De Dion. Among the drivers the tricolor had not all the honors, for Vincenzo Florio, donator of the cup and founder of the Targa which bears his name, was at the wheel of one of the small two-cylinder De Dions. Giuppone, the winner, also claimed Italy as his patrie.

At the end of the first of the two rounds, a distance of 93 miles, Guippone was at the head, his Lion-Peugeot having covered the mountainous course in 3:16:53. Vincenzo Florio had abandoned, together with three other competitors.

The length of the course made it somewhat uninteresting for the spectators, and it would have been really dull but for the admirable telegraphic service which early on the second round brought in news of the overturning of both Naudin and Sizaire, without, however, any accident to the men. Giuppone's victory

was then practically certain. Summarized, the result of the race is:

Lion-Peugeot; driver, Giuppone; average, 28.5 miles an hour.	6:31:30
De Dion; driver, Cammarata.....	6:50:49
De Dion; driver, Isaca.....	7:11:39
De Dion; driver, Olsen.....	8:07:06

The winning car was a single cylinder of 3.9 inches bore and 5.5 inches stroke. Unlike most of the French voitquettes, final

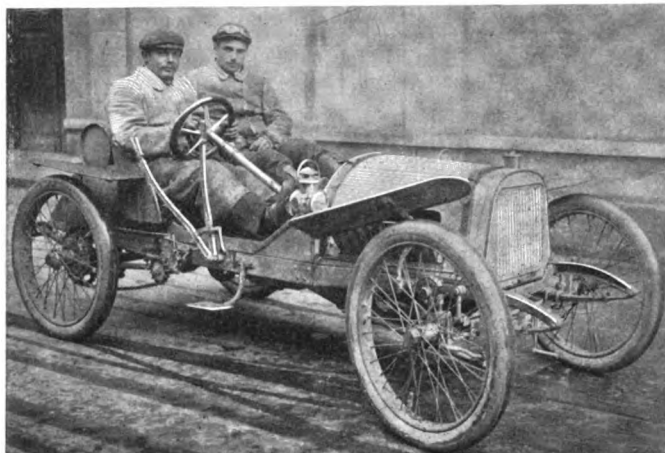

Giuppone, Lion-Peugeot, Winner of the Sicilian Voiturette Race.

drive was by double sidechains. The De Dion cars all had two-cylinder engines of 4.9 inches bore. The winning Lion-Peugeot as well as the two Sizaire-Naudins are engaged to compete in the voiturette Grand Prix on the Dieppe circuit.

## GRAND PRIX ENTRIES MAY BE INCREASED TO FORTY-EIGHT

**P**ARIS, May 22.—It is most likely that there will be 48 cars to start in the French Grand Prix, July 7, for Mors, though not yet officially engaged, has three racers under construction and declares that the double entrance fees will be forwarded to the Place de la Concorde before the end of the month. Since the early days, when success came by leaps and bounds, there have been hard times at the Mors factory and a closing down last year which at one moment looked like a permanent cessation. New financial interests and more vigorous management have recently made a complete transformation and a return to the racing game is one portion of the modern program. Jenatzy has been engaged as racing driver, his two companions yet remaining to be chosen to pilot the other cars of the same nationality.

The four-cylinder cars, the first of which will leave the factory

for road tests this week, have the maximum bore of 155 millimeters and a stroke of 170, which translates to about 6.6. A feature of the engine is that the four separately cast cylinders are double jacketed, one jacket enclosing the circulating water and the other some special substance, the nature of which will not be revealed, for carrying of heat. The details of this feature of the engine are being kept secret. Valve operation, as on so many Grand Prix racers, is by overhead rocker arm, both inlet and exhaust valves being in the head. Main drive has been adopted, the gear set and differential being in one casing, proving three speeds forward and reverse by independent lever. It is declared that the engine has developed 120 horsepower on the testing block and that the maximum speed on the level is 85 miles an hour.

### CIRCUIT ARDENNES TO BE HELD AUGUST 12.

**B**RUSSELS, May 22.—Belgium has decided to hold its annual automobile race on the fast Ardennes circuit under the international rule limiting bore of four-cylinder engines to 155 millimeters. This makes complete the acceptance, in Europe at any rate, of the Ostend rule, France, Italy and Belgium having adopted it and no high-power car races being held under any other conditions. The Belgian meet has been set down for August 12 on the fast Bastogne circuit, the scene of many a record-breaking race. Two other speed tests will be held the same day, one for small runabouts competing for the Crawhez Cup and the other for touring cars running for the Coupe de Liedekerke. The small races will start at 4 A. M., the powerful cars being sent away over the same course at 10 A. M. Entries are received for the 155 millimeter race until June 15.

### HEMERY AND WAGNER IN RUSSIAN RACE.

**P**ARIS, May 22.—Twenty-four cars of all categories are united for the St. Petersburg-Moscow race to be run in connection with the Moscow exhibition, May 31. Main interest lies in the class for racers of more than 130 millimeters bore, which has united a 1908 Grand Prix Benz to be driven by Hemery, a special 150-millimeter Berliet, three 1907 racers from Dietrich, two from Fiat, a Darracq, an Itala and a Mercedes. Wagner will handle last year's Targa Florio races in the 106 to 130 millimeter class, and will have as competitors a Berliet, Nagent, N. A. G., and Darracq. A British Humber and an Italian Clément are alone in the 77 to 105 millimeter class, and seven cars share the low power classes for one, two or four-cylinder engines. There is a promise of considerable automobile trade being done with Russia, a fact that is realized by French constructors.



# THE AUTOMOBILE

Vol. XVIII

Thursday, May 28, 1908

No. 22

## THE CLASS JOURNAL COMPANY

Flatiron Building, Madison Square  
New York City

H. M. SWETLAND, President

### EDITORIAL DEPARTMENT

A. G. BATCHELDER, Managing Editor  
R. F. KELSEY, Associate Editor C. B. HAYWARD, Engineering Editor  
W. F. BRADLEY, Foreign Representative

### BUSINESS DEPARTMENT

A. B. SWETLAND, Business Manager  
LOUIS R. SMITH FRANK B. BARNETT  
W. I. RALPH, 1035 Old South Building, Boston, Mass.  
C. H. GURNETT, H. E. WESTERDALE, 1200 Michigan Ave., Chicago, Ill.

Cable Address - - - - - Autoland, New York  
Long Distance Telephone - - - - - 300 Gramercy, New York

### SUBSCRIPTION RATES:

United States and Mexico - - - - - One Year, \$3.00  
Other Countries in Postal Union, including Canada - - - - - One Year, 5.00  
To Subscribers—Do not send money by ordinary mail. Remit by Draft,  
Post-Office or Express Money Order, or Register your letter.

### FOREIGN SUBSCRIPTION AGENTS:

ENGLAND:—W. H. Smith & Sons, Ltd., 186 Strand, London, W. C., and all their  
railroad bookstalls and agencies throughout Great Britain; also in Paris at  
248 Rue de Rivoli.  
FRANCE:—L. Baudry de Saunier, offices of "Omnia," 20 Rue Duret, Avenue de  
la Grande Armee, Paris.  
GERMANY:—A. Seydel Mohrenstrasse 9, Berlin.

Entered at New York, N. Y., as second-class matter.  
The Automobile is a consolidation of The Automobile (monthly) and the Motor  
Review (weekly), May, 1902, Dealer and Repairman (monthly), October, 1903,  
and the Automobile Magazine (monthly), July, 1907.

Copies printed in 1905	- - - - -	730,000
" " in 1906	- - - - -	791,000
" " in 1907	- - - - -	888,900

## JUST A PLAIN STATEMENT OF FACT.

The American Automobile Association is the only national body of automobilists in this country. The Automobile Club of America was the first automobile club formed in this country. When the clubs of the various European countries first instituted a congress, it was a natural sequence that the A. C. A. should have a voice and speak for this country. Subsequently the American Automobile Association, to meet the needs of the pastime and industry in this country, was organized, and to it came the control of racing and touring and other automobile activities of a general scope. Through a combination of circumstances the A. C. A. was continued as the foreign spokesman of the A. A. A., which had a somewhat varied formative period.

But a year and more ago it first gave positive evidence of the real reasons for its existence, thereby unquestionably causing the apprehension and jealousy of the Automobile Club of America, a coterie in which has tenaciously hugged the idea that the club was and should be national in its operations. Utilizing a disagreement with the New York State Automobile Association over legislative matters, and therein assuming an absolutely untenable position, the A. C. A. flocked by itself, and recently has been endeavoring to use its "foreign relations" as an asset with which to embarrass and undermine the American Automobile Association. The effort is doomed to failure, absolute and humiliating, for it is a matter of

common sense that the general good of automobiling can only be accomplished by an organization which spreads its endeavors throughout the whole country, with local clubs, State bodies, and a cordon of national officers to look after its needs.

Saddled with an enormous debt, liable for fixed annual charges of thousands of dollars, no longer interested in the profitable conduct of automobile shows, the A. C. A. must assure itself of a substantial income from some source or other, and that is why the coterie controlling it desire the overthrow of the A. A. A.—a ridiculous task on the face of it and one which will fail simply because it does not deserve to succeed.

Truly it is a pity that the pioneer club of the country should not be satisfied to be a club itself and thus fulfill its proper destiny. But the handwriting on the wall, now plainly legible, is telling the story, even to those who have been persistently blind and selfishly mistaken in their frequently misdirected efforts to advance the use of the motor-driven vehicle.

The Vanderbilt Cup race will be a bigger success than ever before, and the puerile efforts of the A. C. A. to interfere with its success will only add to the prestige of the big American event.

It is logical, however, that the A. A. A. should figure in the international congresses of the future, and when the foreign clubs comprehend the American situation and realize that it is the A. A. A. which governs in this country, then that body will be asked to speak for America instead of the A. C. A., that no longer will be able to assume a position which now does not belong to it, either logically or morally.



## ONE USE FOR ABANDONED CARS.

It generally has been thought that the cars of the earlier days were of a more fleeting order than their present day successors, and, so far as length of time in the service of the same owner is concerned, this is quite true. But the mere fact that these old cars have disappeared from view completely does not necessarily imply that they have passed away for good. Many of them are commonly accounted for by the fact that they have finally reached a stage where they are only salable in remote districts, and, strange as it may seem, not a few of them are said to have found their way abroad to places where there is no great premium on the latest models, for the reason that the latter are unknown.

A very large percentage of these old timers have not passed away for good, by any means, and even though their power plants are of a degree of efficiency which would make their travel slow and halting beside their latter-day brothers, their motors will still run day in and day out, and they are being utilized in numbers for stationary power purposes, where they may last for a great many years to come. As a matter of fact, not a few instances have come to light in which an automobile is serving its owner in the dual capacity of power plant and road vehicle, occupying one rôle during business hours in the small shop in which it is the boiler, engine and other essentials of the power installation rolled into one, while during the times of its owner's leisure it takes to the road. Many oldtimers doubtless will be doing shop service long after their origin is forgotten.

## DECISIVE VANDERBILT ACTION BY A. A. A. RACING BOARD

THE Vanderbilt Cup Race for 1908 will be conducted under the rules made known weeks ago. The recent so-called protests of two foreign clubs, one of which has never supplied an entrant for the race, were utterly disregarded at the largely attended meeting of the Racing Board, held Tuesday last at the A. A. A. headquarters, No. 437 Fifth avenue, New York City. These protests, transmitted through a club which is no longer connected with the national association, were considered entirely out of order under the existing circumstances.

The A. A. A. is the governing body of automobile activities in this country, including racing, and the fact having been plainly established that it was in nowise holden to the so-called international rules for 1908, it seemed a most logical deduction that Americans could decide as to the conditions under which their big annual race contest should be held. There was no question concerning the unanimity on the proposition at the Tuesday meeting, which was attended by the following:

Jefferson deMont Thompson, chairman, who presided; William K. Vanderbilt, Jr., donor of the cup; A. R. Pardington, ex-chairman of the Racing Board; Thomas Henderson, president of the National Association of Automobile Manufacturers; Percy Owen, chairman of the contests committee of the Importers' Automobile Salon; and these additional members of the board: Frank G. Webb, Long Island Automobile Club; R. L. Lippitt, Rhode Island Automobile Club; Harry W. Knights, Bay State Automobile Association; H. A. Bonnell, New Jersey Automobile and Motor Club; E. R. Thomas, Automobile Club of Buffalo; C. J. Swain, Quaker City Motor Club, Philadelphia; Rossiter Worthington, A. G. Batchelder, H. T. Clinton, New York City; Mayor George W. Tiedemann, holding the proxy of Frank C. Battey, president of the Savannah Club, and Secretary F. H. Elliott.

President W. H. Hotchkiss was also in attendance at the session, and Mr. Henderson, besides representing the N. A. A. M., was proxy for Benjamin Briscoe, of the A. M. C. M. A.

### Stand Taken by French Club Most Unreasonable.

Chairman Thompson brought to the attention of the board certain protests said to have been made by the Automobile Club of France and the Royal Automobile Club of England against the rules for the Vanderbilt Cup race for the year 1908, and at the request of Mr. Vanderbilt attention was called to a letter written by him to Chairman Thompson, in part as follows:

"The stand taken by the French Club is most unreasonable, seeing that for the past three years they have not recognized the Vanderbilt Cup, and their letter to this effect, introduced at this time, would, I think, be a reminder to them that they have refused to participate in this event for reasons known only to themselves. At the same time, the Association was never asked to send its representative to the Ostend meeting held on the 15th of July, 1907, and the minutes of the meetings of the A. A. A. do not refer to any power having been vested in the Automobile Club of America to accept on behalf of the A. A. A. any resolutions adopted at this conference.

"I also wish to bring to your notice the fact that when I presented the cup to the American Automobile Association it was with the intention of giving the American automobile manufacturers a chance of competing against foreign cars in a race to be held in this country, a contest much needed here, and one that I thought would tend to raise the standard of American cars. I believe it is the universal opinion of those interested in the sport that the above stated facts have been achieved.

"It is now, in my opinion, the time for us to notify the French Club of these facts, and receive proper recognition by them."

### Text of Mr. Vanderbilt's Comprehensive Resolution.

After some general discussion of the protests, this resolution by Mr. Vanderbilt, seconded by Mr. Graves, was passed unanimously:

**RESOLVED:** That Jefferson DeMont Thompson, the chairman of this board and of the Vanderbilt Cup Commission, be instructed to notify the corresponding boards or committees of the representative automobile associations and clubs of foreign countries that

the Automobile Club of America is a local club, situated in the city of New York, without national functions or jurisdiction, and

That all communications concerning national or international affairs must be addressed to the American Automobile Association at its headquarters, No. 437 Fifth avenue, New York City, or to the chairman of its respective boards; and

That so far as the rules of the Vanderbilt Cup Race for 1908 are concerned, on receiving a communication direct from any foreign association or club concerning such rules, this board will give such communication prompt and courteous consideration.

That the above resolution is not intended to effect local events and those not national or international in their character, except that sanctions must be applied therefor to the A. A. A.

### Only Three Big Events to Be Sanctioned.

Chairman Thompson then called upon President Hotchkiss to address the board on certain matters of national and international policy, and, after a full discussion, the following resolution, offered by Mr. Thomas, and seconded by Mr. Vanderbilt, who stated that he cordially supported the policy of the association in preventing outlaw contests, was unanimously adopted:

**RESOLVED:** That the chairman of this board be directed to notify all foreign and American clubs and associations, as well as all foreign and American manufacturers, that the American Automobile Association, the national governing body in the United States, will hereafter annually sanction but three national or international events, namely, the Vanderbilt Cup Race for racing cars, the annual touring contest for the Glidden and other trophies, and the DeMont Thompson Cup contest for stock cars; and

That, in accordance with an understanding between the American Automobile Association, the National Association of Automobile Manufacturers, and the American Motor Car Manufacturers Association, as represented in a central conference committee of three bodies, the American Automobile Association will enforce the sanctioning privilege thus committed to it by disqualifying from further contests under its sanction all manufacturers, both foreign and American, and all drivers of whatsoever nationality participating in any race or contest for which a sanction shall be refused or, after notice, withheld.

The effect of this resolution will be (a) to limit national or international contests in the United States to three great events: that for the William K. Vanderbilt, Jr., Cup for racing cars, that for the Glidden and other trophies for touring cars, and that for the DeMont Thompson Cup for stock cars, and (b) to require all clubs and promoters of racing, hill-climbing, endurance and touring contests of a local character to apply for sanctions to the American Automobile Association. Outlaw contests will be penalized by disqualifying entrants and their drivers from all future contests sanctioned by the A. A. A. This action is taken in accordance with the agreement between the American Automobile Association and the manufacturing bodies mentioned, and is intended not only to put racing and other contests absolutely in the hands of the American Automobile Association, but to keep the number of automobile contests within proper bounds.

**CHAIRMAN THOMPSON AND MESSRS. VANDERBILT AND PARDINGTON REITERATED THE STATEMENT MADE AT THE MEETING OF THE RACING BOARD HELD IN APRIL THAT THERE WOULD BE A VANDERBILT CUP RACE THIS YEAR AND THAT PRIOR TO JULY 1 THE COURSE AND THE DAY OF THE RACE WOULD BE ANNOUNCED.**

Upon motion of Mr. Riker, seconded by Mr. Thomas, Chairman Thompson was authorized to name a committee to prepare the entry blanks for the Vanderbilt Cup race for the year 1908, to the end that the same might be published and distributed as soon as possible after June 1. F. G. Webb, Percy Owen, and A. L. Riker were named on such committee, and immediately began work on the preparation of the entry blanks.

Chairman Thompson read a letter from President Frank C. Battey, of the Savannah Automobile Club, which stated in substance that such a club had been approached by the secretary of the Automobile Club of America, but that their club had done nothing with regard to such a race.

## VANDERBILT WILL BREAK GROUND FOR MOTOR PARKWAY

BY way of formally beginning the actual work of construction of the long promised Long Island motor parkway, William K. Vanderbilt, Jr., will, on Saturday, June 6, at half past three o'clock, turn the first spadeful of earth. It has been deemed most fitting and only just that the president of the parkway company, who conceived the idea of this great metropolitan automobile speedway and by whose persevering activity this most important project has been brought to the eve of realization, has well earned this honor. It is planned to make the starting of the building of the parkway somewhat of a ceremonial event. The place selected for the beginning of the work is at a point near Central Park, Long Island, on the Barnes tract at the intersection of the Central branch of the Long Island railroad with the Jerusalem road. It is expected that there will be a large and spontaneous outpouring of autoists to do honor to the occasion.

The awarding of the contract for the laying of the course awakened the fraternity and the public at large to the fact that the promoters of the parkway scheme were not asleep. The turning of the first spadeful of dirt will confirm the promise of the contract and make sure the start and progress of the great work. The management of the Long Island Motor Parkway has been content to fight its preliminary battles without flourish of trumpets and to herald only its actual accomplishments as the campaign progressed. There were seemingly insuperable obstacles to securing an unbroken right of way; but patience and diplomacy have surmounted them and the result is that there has been secured a right of way from the village of Mineola, Garden City and Hempstead, the western terminal to Lake Ronkonkoma extending over a distance of 35 miles. Throughout the entire length, the right of way is 100 feet wide, and in many instances 200 feet. The route in its course traverses many of the beauty spots of Long Island, unknown to the ordinary tourist.

The many possibilities of the Parkway are well known and have been discussed at length by its friends and promoters. When it is considered that all highways and railroads intercepted are to be crossed either above or below grade, and that throughout the

entire distance the highway will be free from speed traps, the benefits to be derived from its use by the man who maintains a summer residence on Long Island can readily be appreciated. As a specially prepared boulevard, the holding of contests of speed, endurance and economy, under actual road conditions, is rendered feasible.

It is interesting to note that practically the same men who were present when the organization of the parkway was first undertaken, are to-day serving in the capacities then assigned to them, as directors, members of committees and officials. This demonstrates the fixedness of purpose of the original promoters and places the ultimate construction beyond question of doubt.

It is interesting also to note that during the recent financial depression which has extended over a period of months, that men of large business affairs, believing in the future of the parkway, have interested themselves in a substantial manner by subscribing to its securities.

The offices of the company during the entire period have been maintained at the first address, No. 527 Fifth avenue, as well as the engineering office in Mineola, which has been a hive of industry from early morning until late at night for the past twelve months. A most effective engineering force, under the direction of W. G. Williams, the chief engineer of the company, has been formed, and has been constantly on the work of surveys, clearing side and center lines, preparing plans and specifications for numerous highway and railroad crossings, making careful study of the contours of the country.

The place where the inaugural will occur may be reached by automobile from Jamaica, by any one of the following routes: Jericho turnpike, direct to Jericho south through Hicksville to Central Park; Jericho turnpike to Queens, thence by the Queens-Hempstead turnpike through Hempstead to Central Park; Old Country road from Mineola to Hicksville, and south on Broadway to Central Park; Merrick road from Jamaica to Massapequa, turn north at Oyster Bay road to Central Park, other but indirect routes also being available.

### NEW YORK'S ORPHANS NOT TO BE FORGOTTEN.

Failing an organization to take up the good work that was so ably carried out by the New York Motor Club, with Samuel A. Miles as chairman on two occasions, in treating the orphans of Manhattan Borough to an automobile ride to Coney Island, a number of public-spirited tradesmen recently got together and determined not to let the event lapse for want of proper support. A meeting was held in the Thoroughfare building, and the owners of the latter donated the use of an office as headquarters. R. G. Howell was appointed chairman of the car and parade committee, and when seen was enthusiastic regarding the prospects for a record-breaking orphans' day celebration this year. The date has been set for June 9, and as soon as an announcement to this effect was made in the press, offers of cars began to come in without solicitation, contrary to the experience of former years. In fact, the prompt voluntary offer of so many cars leads the committee to believe that it will be able to carry every child in the institutions of New York City and Westchester.

### YARMOUTH SLIDES BACK TO DARK AGES.

YARMOUTH, N. S., May 23.—Following the example set by other municipalities and counties of the Province, Yarmouth has taken advantage of the opportunity presented by the recently enacted amendment to the motor vehicle law, to pass an ordinance forbidding the running of automobiles on the city streets from midnight on Friday to the same hour on Saturday of each week. The penalties are \$20 for the first offense, \$30 for the second, and \$50 for the third.

### AUTOS USED DURING CLEVELAND STRIKE.

CLEVELAND, May 26.—The street car strike in this city has given a wonderful impetus to the automobile trade, but it has done more than that, for it has shown conclusively that in an emergency of this kind the auto is the one and only thing which can render valuable assistance. Ever since the strike was declared, the city has had a large number of cars in its service day and night, taking squads of police from one district to another. Officers are kept in waiting at the various precincts for riot calls, and the cars carrying them may be seen speeding across the city at almost any hour of the day or night. The police are free to admit that they would have a hard time coping with the riotous element but for the quick transportation afforded by the cars. The newspaper men have also availed themselves of this feature of modern life, and all four dailies now have three or four cars in service every day.

### DUTY UPON AUTOS REPAIRED ABROAD.

WASHINGTON, D. C., May 23.—The Treasury department is advised that an appeal has been taken from the decision of the United States circuit court for the southern district of New York in the Case of United States vs. W. R. Grace & Co., involving the classification of an automobile repaired abroad. In view of this the Collector of Customs at New York has been instructed to continue to assess duty upon automobiles which have been repaired abroad, pending the final decision of the matter, which may not be made public for quite some time to come.

## WHAT IS GOING ON AMONG THE CLUBS

### PRES. EDWARDS REPORTS ON LONG ISLAND CLUB.

BROOKLYN, N. Y., May 25.—In making his report for the first half of the club year, ending June 1, President Charles Jerome Edwards, of the Long Island Automobile Club, congratulates its members and officers on its substantial growth and increase in influence during that period. He calls attention to the fact that the Long Island club is the only organization in New York City that is a member of the New York State Automobile Association and of the American Automobile Association, and that as such its scope of influence and advantage is very great, and its opportunity for serving its members is correspondingly increased. The club's finances are said to be in excellent condition, the second mortgage bonds having been all retired, while the first mortgage has been reduced by 15 per cent. during the year and a sinking fund created to pay off the balance.

According to the report, the membership has now reached a total of 472. The numerous activities taken in hand by the club are mentioned, among these being the fact that the contest committee of the club has in charge the straightaway time trials to be held on Hillside avenue, Jamaica, June 5. The Legislation committee, consisting of Messrs. Richardson, Webb, Cluff and Field, ably supported the Uniform Registration bill, introduced in Congress by Representative Cocks of Nassau county, and also did a great deal of work in forwarding the interests of the uniform automobile law, following the lines of the Connecticut law, which is generally recognized as fair and reasonable legislation. "It is unfortunate that this bill failed of passage during the last few days of the session," says President Edwards in the course of his report, "because, it is said, of the interference of some Manhattan automobilists, whose appearance was entirely unauthorized."

The Good Roads committee, consisting of A. R. Pardington, chairman, L. H. Allen and C. Litchfield, reports that the Highway bill which passed the Legislature shortly before adjournment, will create for Long Island a trunk line system of highways; one on the north side, reaching from the Nassau county line via Smithtown Branch and Port Jefferson to Riverhead, and one along the south shore, following in the main the Merrick road and its extension eastward. There will also be a link connecting the north and south roads, south from Riverhead. Among the other activities of the club are those of the Runs and Tours committee, consisting of Messrs. Lefferts, Alderman and Hunt, which is preparing an attractive program, and the Country House committee, which has charge of the recently acquired country house, at Bayshore, Long Island.

### HELLER NAMES N. J. A. AND M. CLUB COMMITTEES.

NEWARK, N. J., May 26.—President Paul E. Heller has named the New Jersey Automobile and Motor Club's committees for the ensuing year. They and their chairmen are: Legal, William F. Kimber; house, Charles W. Baker; legislative, W. C. Crosby; membership, Frederick A. Crosselmire; race, William C. Shanley; auditing, John K. Gore; good roads, Joseph H. Wood.

The club now has about 900 members, and as applications are being received at the rate of five a day, Secretary LeMassena is confident that the membership roll will pass the thousand mark in the near future, probably during the month of June. Its greatly increased membership will be put to effective use by the officers of the club in waging their fight at the next legislature for more reasonable motor vehicle laws. Plans for this campaign are already being laid. The board of trustees of the club have appointed Dr. James R. English, Dr. Frank B. Meeker and Frederick A. Crosselmire a committee to arrange for an orphans' day outing which the club has decided to hold some time in June or July. It is also planned to hold an endurance contest in the fall, to be open to members only.

### THOUSAND MILES FOR CHICAGO MOTOR RUN.

CHICAGO, May 25.—Delayed by the hill climb in the preparation of rules for its four-day reliability run next month, the Chicago Motor Club was unable to announce the regulations until to-day, when the technical committee completed its work. The report shows a revision of the plans in that, instead of asking the cars to make a triple century a day, the distance is shorn to 250 miles per diem, making a total of 1,000 miles instead of 1,200. There has been a segregation of the touring cars and the roadsters, and, while they will follow the same routes, they will be competing for a different set of prizes. There are four classes in each division and each class has a different schedule.

In the roadster class, A will be for cars listing under \$1,000, and the schedule calls for 16 miles per hour; class B is for cars from \$1,000 to \$1,999, and will do 18 miles per hour; class C, from \$2,000 to \$2,499, and class D, for cars from \$2,500 up, will do 20 miles per hour.

In the touring car division, class F is for cars from \$1,000 to \$1,999, and class F from \$2,000 to \$2,499, and their schedule will be 18 miles an hour. Classes G and H, the first from \$2,500 to \$3,999, and the other from \$4,000 up, will maintain a pace of 20 miles an hour.

Prizes will consist of trophies and medals. In addition there will be a trophy, which has been given by the Standard Oil Company, which goes to the car with the least gasoline consumption, figured on a ton mileage basis.

### DOCTORS FORM AN AUTO ASSOCIATION.

ORANGE, N. J., May 25.—The Physicians' Automobile Association of the Oranges has just been formed here with a charter membership of 40 of the local healers who are advocates of the automobile. The officers of the newly organized association are: President, Dr. Edgar C. Siebert; vice-president, Dr. Palmer A. Potter; secretary, Dr. Stephen G. Lee; treasurer, Dr. Arthur W. Bingham. The board of governors is composed of the following: Dr. Thomas W. Harvey, Dr. Mefford Runyon and Dr. Richard D. Freeman. Quarters have been taken in the rooms of the William Pierson Medical Library Association in the Orange Free Library Building.

### OHIO AUTOISTS TO TOUR TO BUFFALO.

CINCINNATI, May 25.—C. Gordon Neff, of the Automobile Club of Cincinnati, and vice-president of the Ohio State Automobile Association of the American Automobile Association, is setting an excellent example to his brother autoists in other States, by organizing a run of autoists from all parts of the "Buckeye" State to Niagara Falls and Buffalo, the dates being scheduled to reach the latter place in time to take part in the big legislative and good roads convention that will be held July 6-8. Mr. Neff is a member of the Good Roads committee of the three A.'s and is doing excellent work.

### MARYLANDERS AFTER GOOD ROADS.

BALTIMORE, Md., May 23.—Members of the Automobile Club of Maryland, owners, dealers, manufacturers and agents in Baltimore and Howard, Frederick, Washington, Allegany and Garrett counties, which will be held at Hagerstown early in June for the purpose of inducing the State Highway Commission to lend its aid in a movement for one main artery of improved highways from Baltimore City, through Frederick, Hagerstown and Cumberland, to Grantsville, Garrett county. United States Senators John Walter Smith and Isidor Rayner, Congressman George A. Pearre, members of the legislature, the State road engineer, county road engineers, directors and commissioners and members of the press throughout the State have also received invitations



to attend the gathering. The State Highway Commission and Archer B. Hulbert, author of many articles on improved highways, have also been asked to attend. The plan in view is to utilize the old Baltimore and Cumberland turnpike and the old National road for this proposed vast improvement. The guests will go to Cumberland the day following the meeting, where a banquet and reception will be held.

The Good Roads Commission, headed by Governor Crothers, has inaugurated plans for improved highways in Maryland. The first step was an inspection visit the past week to southern Maryland. Similar trips will be made to the Eastern Shore the coming week and to the Western Shore beginning June 3.

#### WASHINGTONIANS WILL TOUR THREE STATES.

WASHINGTON, D. C., May 23.—Members of the Automobile Club of Washington are looking forward with interest to the club's initial tour of the year, which will take place May 29-31 and which will take the tourists into three different States—Maryland, West Virginia and Pennsylvania. The tourists will start at noon on May 29 and proceed leisurely to Harper's Ferry, W. Va., via Frederick. The second day's run will be from Harper's Ferry to Gettysburg, via Winchester, Martinsburg, Hagerstown and Waynesboro. Sunday will be spent in touring the Gettysburg battlefield and making the trip homeward. The route selected for this tour is through a country rich in historical interest, while the roads and scenery are the best to be found in this section of the country.

President Caverly and John K. Heyl and W. D. West were appointed delegates to the A. A. A. convention in Buffalo, July 7-9. President Caverly will bring to the attention of the convention the project of constructing a Lincoln memorial boulevard from Washington to Gettysburg. As the 100th anniversary of Lincoln's birth will occur next year, it is suggested that the proposed boulevard would be a fitting tribute to the martyred president. It is believed automobilists throughout the country will indorse the project.

#### ONE MORE CLUB FOR THE OLD DOMINION.

SUFFOLK, VA., May 26.—In response to a call signed by twenty-five of the forty owners of automobiles in the city, a meeting has been held resulting in the formation of the Suffolk Automobile Association, and the election of the following officers: President, C. A. Sharpe; first vice-president, William N. McAnge; second vice-president, Benjamin L. Saunders; secretary-treasurer, R. L. Gaskins. Application for membership in the State association of the A. A. A. was directed to be made by the secretary. Chief among the objects of the club as embodied in the call for the meeting were to secure speed laws, giving due protection to the public while not unreasonably hampering the use of motor cars for pleasure driving and also to promote highway improvement.

#### NEW HAVEN AUTOISTS ORGANIZE TO DO GOOD.

NEW HAVEN, CONN., May 25.—After many desultory efforts covering several years New Haven at last has an automobile club which bids fair to being a success. A club has been organized with thirty-two charter members, with these officers: President, Thomas G. Bennett; vice-president, Jacob P. Goodhart; secretary, Amos F. Barnes; treasurer, William H. Douglas. There will be five committees, membership, contest, rights and privileges, good roads, and sign post, each composed of three active members. Great care was exercised in drafting the constitution and by-laws, and these differ in several respects from those of most other clubs. Two clauses read as follows:

"The committee on rights and privileges shall have charge of all alleged infringements of the legal rights of the club or its members, and shall advocate and endeavor to obtain proper privileges for and protection of the members in the use of the highways and parkways.

"It shall be the duty of the committee to receive complaints from any person in regard to reckless driving or violation of any automobile statute or ordinance, or of the rules of the road, by any autoist, and immediately upon the receipt of such complaints

the committee shall send a warning to the person or persons complained of, in the name of the club. If a second complaint is received a second warning shall be sent, notifying the party complained of that unless he complies with the law the club will assist in his prosecution. If such person after the second warning shall continue to violate the laws of the State or the ordinances of any city, town or borough this committee shall bring the matter to the attention of the proper authorities and assist in the prosecution of such person in such manner as it shall deem best."

#### WILLIMANTIC CLUB COMPLETES ORGANIZATION.

WILLIMANTIC, CONN., May 25.—An enthusiastic meeting of the recently formed Willimantic Automobile Club was held here last week, at which the organization of the club was completed. Dr. John Weldon, who was elected president at the last meeting, was in the chair. The by-laws drafted by the board of governors were submitted and approved, and were subscribed to by 30 charter members. As there are only about 50 resident automobile owners in this section, the club has made a very good start. A letter was read from Guy K. Dustin, of the Connecticut State Automobile Association, asking the local club to elect a director in the State body. De Witt C. Hill was chosen for the place, and will attend the next meeting of the directors of the State association, to be held at the Atlantic House, Bridgeport, May 30. The matter of providing automobiles for the members of the local G. A. R. post on Decoration Day was also taken up, and the members of the club agreed to use their cars for this purpose.

#### BUFFALO CLUB WINS CASE AGAINST CITY.

BUFFALO, May 25.—A decision in favor of the Automobile Club of Buffalo in the action brought against Secretary Dai H. Lewis to test the validity of the municipal tax of \$5 a year, has just been handed down by the Court of Appeals. The case was tried in the first instance before Judge Hodson, of the Municipal Court, who ruled against the city on the ground that the municipality had no legal right to impose an additional tax on the use of an automobile. The opinion of the Court of Appeals reads, in part, as follows:

"When the occupation or use of a public street involves danger in some degree to the public, a license may operate as a partial restraint upon such use of the public streets. The purpose of the ordinance in question to restrain the use of motor vehicles in the public streets of Buffalo is so obvious that very little weight can be given to the fact that it is called a tax instead of a license. We think that the ordinance is a plain attempt to avoid the provisions of the motor vehicle law, and that it should not be upheld."

#### CLUBS RAPIDLY FORMING IN NUTMEG STATE.

HARTFORD, CONN., May 25.—Rockville, a manufacturing town about 15 miles east of this city, is the latest to add an automobile club to the State's rapidly growing list of organizations. A number of progressive autoists got together there recently and formed the Automobile Club of Rockville, several of the members already being affiliated with the Automobile Club of Hartford. The newly formed organization has already been admitted to the Connecticut State Automobile Association, and, through the latter, to the American Automobile Association, and has signaled its existence by preparing to hold a hill-climb on New England Hill in connection with the Old Home Week celebration—a typical Down East institution.

#### CLEVELAND CLUB'S RUN TO CAMBRIDGE SPRINGS.

CLEVELAND, May 26.—Starting the morning of Decoration Day, May 30, and continuing for three days, the annual run of the Cleveland Automobile Club to Cambridge Springs promises to be the best event of its kind ever held by the local club.

The run to Cambridge Springs is an annual event, but never before have such preparations been made to insure its success. Among other things which will be given for the benefit of the tourists will be an amateur minstrel show and dance. Non-members of the club may also go upon this run, first securing a card through a member. The distance to the Springs is approximately 110 miles and the roads are in very fair condition.

## NINETEEN PERFECT SCORES IN INDIANA SEALED-BONNET RUN

INDIANAPOLIS, IND., May 21.—The first reliability run or sealed-bonnet contest ever held in Indiana was run May 20 by members of the Indianapolis Automobile Trade Association, covering a course of approximately 150 miles through Central Indiana. Out of thirty-seven starters, nineteen finished with perfect scores. Ten out of the fifteen cars in Class A, which was for machines listing over \$2,500, were perfect; five out of the six in Class B, \$1,500-\$2,500, went clean, and four out of sixteen in Class C, under \$1,500, escaped penalty.

Those with perfect scores were as follows: Marmon, three; National, two; Premier, two; Maxwell, two; White, Haynes, Bulck, Rambler, Rapid, Lambert, Marlon, Mitchell, Overland, Reo, one each.

Some of the worst hills in Indiana were encountered, and there were long stretches of dirt roads, and in several places the heavier cars sunk almost hub deep in them. The day, however, was perfect for such a contest. On Monday and Tuesday rains eliminated the dust, and on Wednesday the highways were just damp enough to keep dust from flying. There was just a trace of wind, and the sun shone brightly throughout the run. Tuesday afternoon the contesting cars were turned over to the technical committee for examination and sealing, and they remained parked on the Meridian street side of University Park all night.

Promptly at 7 o'clock, W. C. Marmon, driving a Marmon, crossed the tape as the first to start on the long run. Then the cars began leaving one minute apart, with ten minutes between classes, and every car left on time to the second. Leaving Indianapolis, the cars went north through Crow's Nest to the

road leading to Westfield, thence to Noblesville and Anderson, the latter city being the first checking station. From there the route led east to Muncie, thence to Newcastle, and from there to Indianapolis, through Dunreith, Knightstown and Greenfield, the last 40 miles being over the National road. At Anderson, while the cars were waiting to check in, the Buckeye Manufacturing Company, which makes the Lambert, gave the occupants of each car box lunches, and at Newcastle the Maxwell-Briscoe Motor Company provided roses.

The technical committee drew the line very closely, almost splitting hairs, in the final examination of the cars, yet despite this fact there was not a single protest from its decisions. A penalty of 25 points was incurred for each broken seal, with a penalty of two points for each minute spent in working on the car. Additional penalties were incurred for loose and broken parts found at the conclusion of the run. Without doubt the most interesting feature of the run was the perfect score made by a twelve-passenger Rapid 'bus, entered by Frank Grogan, an eighteen-year-old boy.

The rules and technical committee was composed of W. G. Wall, of the National Motor Vehicle Company; Howard Marmon, of the Nordyke & Marmon Company, and George A. Weideley, of the Premier Motor Manufacturing Company, chairman. The contest committee was: Frank Staley, of the H. T. Hearsey Vehicle Company; A. E. Vinton, of the G & J Tire Company; Frank Moore, of the Fisher Auto Company; P. D. Stubbs, of the Overland Automobile Company; Paul Smith, of the Indianapolis Motor Car Company, and George Weideley.

## ALBANYITES OF NEW YORK STATE HAVE A SUCCESSFUL CLIMB

ALBANY, N. Y., May 23.—Though hill-climbing events have not been included in its catalogue of activities in the past, the Albany Automobile Club's first contest, which was held on Menands hill to-day, proved conclusively that the successful management of such an affair was something easily accomplished by the organization. The course had been affected somewhat by Friday's rain, but the treatment of oil it received subsequently put it in fine condition for the climb. A hill-climb is a novelty in this district and an immense crowd was attracted, lining the entire course from start to finish.

The free-for-all events and the special for six-cylinder cars provided the major portion of the excitement of the day. The former brought forth two double winners, C. S. Ransom's Stevens-Duryea "six" making the best time of the day, :53 1-5,

in the free-for-all touring cars, while he brought the same car home a winner in the six-cylinder event in :54 4-5 seconds.

In the free-for-all runabouts, Chauncey D. Hakes' Apperson "Jackrabbit" made the half-mile grade in :58 1-5, and in the event for runabouts listing above \$3,000 repeated its performance by winning in exactly the same time. A Knox was second and a Locomobile third.

In addition to the Stevens-Duryea "six" taking first in the touring car and six-cylinder events, cars of the same make also took first and second places in each, while in the latter a Stevens-Duryea was also third, a Pierce Arrow coming in fourth. There were four other events for gasoline touring cars listing at different prices, and five events for runabouts, the prizes offered in each case consisting of gold cups.

<b>FREE-FOR-ALL TOURING CARS—ALL MOTIVE POWERS.</b>	
1. Stevens-Duryea (six) .....	C. S. Ransom..... :53 1-5
2. Stevens-Duryea (six) .....	Samuel Parsons..... :1:09
3. Flat .....	J. B. Taylor..... :1:09 3-5
4. Thomas Flyer.....	W. H. Buckley..... :1:10 2-5
5. Stevens-Duryea (light six).....	Karl Isburgh..... :1:10 3-5
6. Lozier .....	Parker Corning..... :1:12
7. Pierce Arrow.....	J. P. Randerson..... :1:20 2-5
8. Welch .....	Lucey Motor Car Co..... :1:23
<b>SIX-CYLINDER CARS—\$6,000 AND OVER.</b>	
1. Stevens-Duryea .....	C. S. Ransom..... :55
2. Stevens-Duryea .....	G. Y. Lansing..... :1:01 3-5
3. Stevens-Duryea .....	Samuel Parsons..... :1:10
4. Pierce Arrow .....	J. P. Randerson..... :1:12
5. Stevens-Duryea .....	Karl Isburgh..... :1:17 1-5
<b>GASOLINE TOURING CARS—OVER \$3,000.</b>	
1. Locomobile .....	E. W. Leahy..... :1:09 3-5
2. Flat .....	J. B. Taylor..... :1:10
3. Lozier .....	Parker Corning..... :1:11 3-5
4. Thomas Flyer.....	W. H. Buckley..... :1:12 4-5
<b>GASOLINE TOURING CARS—\$2,001 TO \$3,000.</b>	
1. Thomas 40.....	J. C. Birdseye..... :1:06 4-5
2. Pope-Hartford .....	Troy Auto Exchange..... :1:18 2-5
3. Elmore .....	George W. Waitt..... :1:45
<b>GASOLINE TOURING CARS—\$1,251 TO \$2,000.</b>	
1. Maxwell .....	W. Klingsburg..... :1:33
2. Maxwell D .....	Central Auto Co..... :1:45 1-5

<b>GASOLINE TOURING CARS—\$851 TO \$1,250.</b>	
1. Cadillac .....	..... :1:36
<b>FREE-FOR-ALL RUNABOUTS—\$5,000 AND OVER.</b>	
1. Apperson Jackrabbit.....	C. D. Hakes..... :58 1-5
2. Knox Model L.....	Knox Auto Co..... :1:01 1-5
3. Locomobile .....	Taylor Auto Co..... :1:04
4. Locomobile .....	Taylor Auto Co..... :1:05
5. Stoddard-Dayton .....	J. Smith Jacobs..... :1:10 3-5
6. Stoddard-Dayton .....	C. A. Warren..... :1:12 1-5
7. Knox Model H.....	Knox Auto Co..... :1:14
8. Oldsmobile .....	A. J. McClure..... :1:15
9. Reo .....	B. A. Burtiss..... :2:00
<b>RUNABOUTS—\$3,000 AND OVER.</b>	
1. Apperson Jackrabbit.....	Chauncey D. Hakes..... :58 1-5
2. Locomobile .....	Taylor Auto Co..... :1:05
3. Locomobile .....	Taylor Auto Co..... :1:05
<b>RUNABOUTS BETWEEN \$1,251 AND \$2,000.</b>	
1. Maxwell K.....	Central Automobile Co..... :1:28 3-5
2. Stoddard-Dayton .....	C. V. Yukers..... :1:39
3. Aerocar .....	Schenectady Auto Exch..... :1:44
<b>RUNABOUTS BETWEEN \$851 AND \$1,250.</b>	
1. Reo .....	B. A. Burtiss..... :1:46 3-5
<b>RUNABOUTS—\$850 AND UNDER.</b>	
1. Ford Model L.....	C. F. Weeber Mfg. Wks..... :1:35 1-5
2. Ford Model S.....	F. B. Harrington..... :1:35 2-5
3. Ford Runabout.....	F. W. Battershall..... :1:41 1-5
4. Maxwell .....	Schenectady Auto Exch..... :1:49

## THOMAS WALLOWES STEADILY THROUGH SIBERIAN SLOUGHS

ACCORDING to advices received by the *New York Times*, from Nikolsk, Siberia, the Thomas crew has been struggling against odds that make the mud of the Iowa prairies and the snows of the Rockies mere child's play by comparison. Schuster's account of their struggles thus far, states that they only saw the sun once from Friday to Monday, and shortly after its reappearance were again overtaken by a violent thunder storm which converted the whole stretch of lowland into a miniature sea, so that it was necessary for the crew to wade ahead in order to pilot the driver. They finally landed in the middle of a stream, from which it was necessary to extricate the car with the tackle and the route was retraced several miles to a small village where the night was spent. It was learned there that the Protos had been making good time over the railroad ties while the Thomas crew was struggling with the mud and had gained a good lead, and the Americans will henceforth abandon the road for the right of way.

The start from Vladivostok was delayed from Wednesday to Friday owing to a last desperate attempt of St. Chaffray of the De Dion crew to continue in the race. The French car having been formally withdrawn, St. Chaffray determined to get a place on the Thomas and to insure this end quietly cornered the avail-

able gasoline supply. He then asked for an interview with the American crew and offered his rights to the precious fluid for a place on the Thomas, which was indignantly refused by Schuster who would not consider the Frenchman's company on any conditions, even if they had to wait indefinitely. Lieutenant Koeppen and the Protos crew declined to take advantage of the American's predicament and waited until they could start together. American residents and Russian officials emptied the tanks of their launches while others contributed toward a sufficient supply to enable the Americans to get away after a delay of but two days.

The Russian officials have aided the contestants in every way, the Governor-General of the province sending his Adjutant along as a guide for the first stretch of 100 miles, while Schuster has been provided with papers instructing the commandants of all the Cossack posts along the route to aid the drivers in every way. The military authorities have also furnished maps and information concerning the roads and supply stations along the route. Captain Hansen, who is the Russian interpreter for the party, has found no difficulty in making arrangements. It required two days of the hardest kind of work to make 94 miles, during which the Thomas pulled the Protos out of the mud.

## ONE ATTACK UPON NEW JERSEY LAW'S CONSTITUTIONALITY

TRENTON, N. J., May 25.—Not because the program had not been arranged with due attention to the details, but because the chief actor had not lived up to his part by staying arrested for violating the Jersey law, Judge Lanning, sitting in the United States District Court, dismissed the application of R. H. Johnston for a writ of *habeas corpus* to-day. In accordance with a plan outlined by X. P. Huddy, of counsel to the White Company, Mr. Johnston drove a White steamer into Trenton on Friday last without the formality of having procured a Jersey license. The Trenton police department had been notified well in advance, otherwise Mr. Johnston might have found it difficult to be arrested, but no less a person than police captain John J. Cleary took him into custody. There was the usual hearing at which the prisoner pleaded not guilty, and the magistrate fixed Friday, May 29, to hear the complaint. In the meantime Johnston followed the even tenor of his way by promptly departing for another jurisdiction, while his counsel drew up an application for a writ of *habeas corpus* to get him out of the supposed durance vile of a Jersey prison. The idea was to bring the matter before the Federal courts on the ground that the prisoner was engaged in interstate commerce, thus avoiding the long preliminary delay of dragging it through the State courts, but Judge Lanning thought the scheme was too transparent. There was no prisoner. Hence, the court had no jurisdiction to grant a writ for his release.

Mr. Johnston immediately became a prisoner in reality upon

the dismissal of the application for the writ, and gave his machine as security for his appearance before Police Judge Harris next



H. R. Johnston Undergoing Arrest at Trenton, N. J.

Friday. Following the hearing of the case before the police magistrate, it is the intention of counsel to bring the case before the New Jersey Supreme Court on a writ of *certiorari*.

## AUTO TRAPS NUMEROUS IN NEW JERSEY THESE DAYS

UP to this time there have been few auto-traps in that part of New Jersey around Englewood; but (emulating the example of various other places), two or three of the cities and towns in that district have started in to get their share of the autoist's spare change.

A week ago last Sunday the little town of Tenaflly had its "trap," and among the various arrests was the Mayor of Englewood, who left a matter of \$8 or so with the Tenaflly authorities. On the following Sunday Englewood had its own trap, and got back several times what its mayor was out a week before. This latter trap was located on Engle street,

between Palisade and Hamilton avenues, near the business center, where there is a more or less steady procession of autoists, especially Sunday afternoons.

We are informed upon reliable authority that within the past six years there have been only two accidents in Englewood—one of them due to carelessness on the part of the autoist, and the other to a deaf-and-dumb person, after which occurrence the autoist was exonerated. So far as we are able to learn, there has never been an accident in Tenaflly, and it is difficult to see any reason for the existence of traps in either one of these places.

**A. L. A. M. ADOPTS FURTHER STANDARDS.**

In furtherance of its policy of adopting standard forms of construction wherever these may be consistently used by all the members of the association in the construction of their cars, the Association of Licensed Automobile Manufacturers has had its

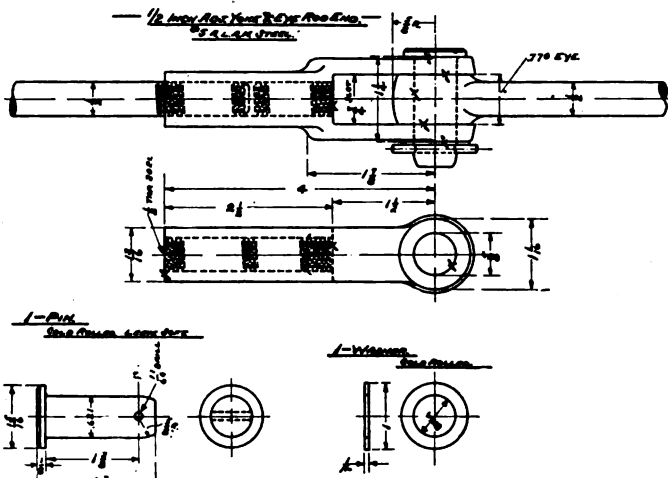

Assembly A. L. A. M. Adjustable Yoke and Eye Rod End.

Mechanical Branch draw up specifications for standard forms of yoke and eye rod ends. This is the third formal set of standards adopted by the association, the first being that screws, nuts and bolts, while the second was the A. L. A. M. standard spark

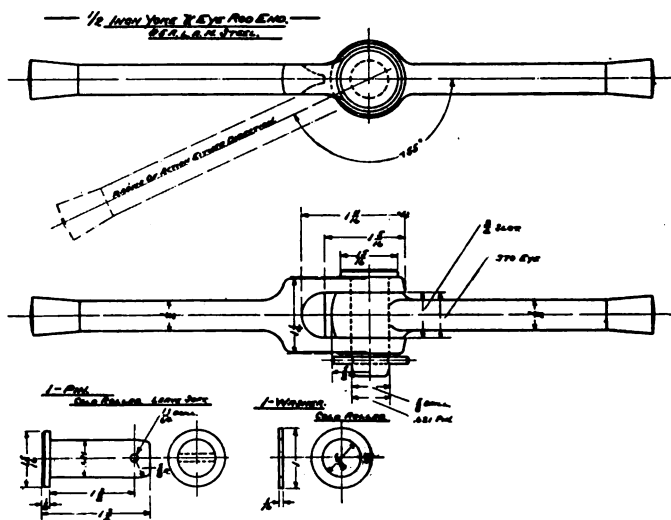

Assembly and Details A. L. A. M. Fixed Yoke and Eye Rod End.

plug. The accompanying drawings show the details of the proposed standards for yoke and eye rod ends in the 1/2-inch size. The sizes given in the circular announcing the standard are 1/4, 5-16, 3/8, 7-16 and 1/2-inch. Copies of the circular in question giving detailed drawings of each one of the sizes mentioned, may be had by car or parts manufacturers on application.

**FURTHER PROSECUTIONS IN LAMP LITIGATION.**

Following up the injunction against the Saxon Lamp Company, forbidding the latter to manufacture or sell colorable imitations of the Rushmore designs, the Rushmore Dynamo Works, Plainfield, N. J., has further prosecuted this concern for failing to obey the court's order by bringing out a lamp differing but slightly in detail from the one on which the injunction was originally obtained. After hearing the case, Judge Ray decided that the defendant had wilfully and knowingly violated the injunction in question and adjudged him in contempt, imposing a fine of \$500.

**ENGINEERS MEET AT CLEVELAND PLANTS.**

CLEVELAND, May 23.—As a result of the new plan recently adopted by the Association of Licensed Automobile Manufacturers to have its technical men be given every opportunity to visit the plants of the different makers in the association, the Mechanical Branch met in this city yesterday.

The morning session was devoted to a discussion of the report on the recent checking tests made on the dynamometer of the Automobile Club of America in New York, a fortnight ago. Henry Souther, the recently appointed chairman of the technical committee of the Automobile Club of America, was present and expressed the gratification of the club as to the action of the Licensed Association in testing the dynamometer. Following the reading and discussion of the report, a paper on the two-cycle motor was read by E. W. Roberts, and this was in turn followed by a paper on combination valves for four-cycle motors, by C. E. Thompson, of the Electric Welding Products Company. The valves referred to are those in which a nickel-steel head is welded on to a carbon-steel stem. The fact that the metal may be injured by the high heat necessary for welding was brought out, and to overcome this it is the practice of the makers in question to resort to heat treatment after welding. Both papers were followed by discussions of the subjects in question.

In the afternoon, the engineers visited the plants of the Peerless Motor Car Company, the F. B. Stearns Company and the Winton Motor Carriage Company. Those in attendance were: A. L. Riker, chairman, and A. C. Schulz, Locomobile Company; George W. Dunham and C. J. Kryzanowsky, Olds Motor Works; Russell Huff, Packard Motor Car Company; E. H. Parkhurst and W. H. Staring, Peerless Motor Car Company; David Fergusson, George N. Pierce Company; J. G. Sterling, F. B. Stearns Company; John G. Utz, E. R. Thomas Detroit Company; Thomas Henderson, H. B. Anderson, C. D. Smith and Charles W. Mears, Winton Motor Carriage Company; E. P. Chalfant, assistant general manager of the Licensed Association; Henry Souther, consulting engineer, and C. F. Clarkson, secretary of the Mechanical Branch.

**FRANKLIN SUCCEEDS WITH ALCOHOL MOTOR.**

Although their experiments with alcohol as a motor fuel were productive of successful results at first, the engineers of the H. H. Franklin Manufacturing Company, Syracuse, N. Y., persevered and their efforts have now been attended with unlooked-for results. It will be recalled that only recently the Franklin engineers announced that their findings did not warrant the belief that there was any immediate future for the alcohol motor, and it was pointed out that even if gasoline and alcohol could be purchased at the same price the advantage in favor of the former would preponderate greatly. Since then, however, they have succeeded in perfecting an alcohol motor which shows as high a degree of efficiency as one using gasoline, and that without the expedient of employing a very high compression as has usually been found necessary. It also has the further advantage of being equally economical in the use of fuel, a consumption of as low as 1.05 pounds per brake horsepower hour having been achieved, while there are no detrimental effects on the motor itself from using this fuel. Were both fuels on a par, it would be equally economical to use either alcohol or gasoline in this motor, and this means a tremendous step in advance, particularly for commercial vehicle use, as the cost of fuel is an item of great importance in this connection.

The announcement to this effect has aroused a great deal of interest, particularly from distillers of denatured alcohol, the United States Industrial Alcohol Company immediately having undertaken an investigation of the Franklin motor. Apart from the fact that the new motor, which has been proven perfectly practical for automobile use, does not use a compression exceeding 90 pounds to the square inch, nothing concerning its technical details is forthcoming.



### NOT SATISFIED WITH WHAT IS AVAILABLE.

CHICAGO, May 25.—Alfred Reeves, general manager of the American Motor Car Manufacturers' Association, is expected in Chicago shortly to discuss with the two local clubs a suitable location for the show which the independents may hold in Chicago next Winter. Manager Reeves has written the Chicago Automobile Club regarding the two locations offered by the club, declaring that the Dexter Park pavilion at the stockyards does not come up to the mark so far as location is concerned, although it has more than enough floor space.

The other building, the Seventh regiment armory, now in course of construction at Wentworth avenue and Thirty-third street, is admirably situated, but the floor space is insufficient. It is cut up into two floors, and the first floor would not begin to accommodate the manufacturers of cars. In the Dexter Park pavilion are held the annual stock shows and the affair draws out great crowds. Next winter there will be a spur of the elevated which will make it conveniently accessible.

### TIREMAKERS CONSIDER PRICE-CUTTING.

CLEVELAND, May 25.—That the prices of automobile tires may be changed next year is the very probable outcome of the meeting of the tire committee of the Motor and Accessory Manufacturers, held in this city May 21. While no drastic action with immediate bearing upon the future was taken, the consensus of opinion is that a reduction in prices will be the final result. The meeting in this city was the result of continued price-cutting all over the United States for the past few months, and the tire committee decided to take some action upon the matter. The Cleveland branches of the tire companies have been powerless to stop the war, and appealed to the factories for help.

Another factor in the situation has been the club proposition, which the tire and accessory makers desire to have regulated before its further spreading. Club members securing inside prices is seriously cutting into the business of the accessory dealers and is generally considered detrimental to the trade, which fears that it may even extend to the buying of cars.

Within the next few weeks a letter will be sent to every automobile and tire dealer in the United States, laying the status of the matter before each one individually, and requesting an expression of opinion as to whether or not the price to the consumer had not better be changed. The tire men figure that if the price to the consumer is reduced somewhat, there will be less incentive to buy from the price cutters, and that they in turn cannot afford to offer goods at as low a figure as has been the case in the past. Another meeting of the tire committee will be called for July 25, and definite and lasting action will then be taken. At the meeting here practically every tire manufacturer in the United States was represented with the exception of the Michelin Company.

### BOSTON REPORTS TRADE HEALTHILY BOOMING.

BOSTON, May 18.—The local automobile trade is experiencing a marked boom, and since the first of the month business has been better than during any similar period this season. All through the automobile districts the dealers are reporting a good business, and some of them are running short on prospective deliveries of certain models. The approach of Summer and good touring weather is given the credit for the expansion of business and the trade feels very well satisfied with the conditions and the prospects, as most of the sales now being made are for immediate delivery. Alvan T. Fuller, who handles the Packard, last week made his last delivery of the 1908 model of this car, and several other dealers, notably J. W. Bowman of the Stevens-Duryea, have oversold allotments of some models.

The excellent condition in the trade is reflected at the office of the Massachusetts Highway Commission where since the first of the month cars have been registered at the rate of 90 a day, the total registered since the first of the year being about 12,000.

### CHAIRMAN THOMPSON APPOINTS MEMBERS.

Jefferson deMont Thompson, chairman of the A. A. A. Racing Board, has announced the appointment of Robert Graves and Harry T. Clinton as members. Mr. Graves is a pioneer American autoist, having entered cars in two of the Vanderbilt Cup races. Mr. Clinton is manager of the publicity department of the Association of Licensed Automobile Manufacturers.

### QUAKER CHAUFFEURS' PROGRAM.

PHILADELPHIA, May 25.—To increase interest in its organization and to attract the better class of men, the Philadelphia Mechanical Chauffeurs' Association will, beginning Friday evening next, May 29, inaugurate a series of lectures upon mechanical subjects relating specially to the manufacture and operation of automobiles. The subject for the first lecture has been announced as "Magnetos," and will be handled by a representative of the Bosch Magneto Company, of New York.

### REAL ESTATE MEN START AUTO CAMPAIGN.

PATERSON, N. J., May 25.—Realizing the value of the automobile as a means of showing property in outlying districts, the New York-New Jersey Real Estate Exchange has organized a campaign of personally conducted automobile trips to those sections of New Jersey in which development operations are now in progress. Under the guidance of Otto Kempner, president of the Exchange, the first of these trips was held last Saturday, a large party of New Yorkers interested in Jersey realty being carried out to this city, where they were met by a score of touring cars in charge of a committee consisting of E. H. Lambert, Louis A. Piaget, Henry Snyder and Judge Kerr. About 100 of the visitors were tendered a luncheon at the Hamilton Club, where the advantages of Paterson and its suburbs were extolled by Senator John Hinchcliffe, Dr. Shaw, Judge Van Cleef and others, following which the decorated cars paraded through the streets. Castle Lambert and its art gallery were inspected, the visitors were received by Mayor McBride at the city hall, and were later entertained at the North Jersey Country Club.

### PHILADELPHIANS TO HAVE AUTOCABS.

PHILADELPHIA, May 25.—"Gasoline Row" was agog early last week over the arrival here of ten Thomas taxicabs. The excitement was due not so much to the arrival of the vehicles—for that had been expected—but that they were taken to the big new garage of the Bergdoll Motor Car Company, at Broad and Wood streets. Later it developed that R. A. Park, who, rumor has it, will manage the Thomas cab system here, had set up his desk in the Bergdoll office, and it was bruited along "the row" that those who had been storing their cars at the Bergdoll plant had been given notice to move at an early date. All of which is circumstantial evidence that the young millionaire brewer and crack driver at the head of the company is preparing for a comprehensive campaign to exploit the Thomas taxicab here. Although direct questioning both at the local Thomas agency and at the Bergdoll offices failed to elicit any definite information as to when the service will be inaugurated, it was stated in a general way that "plans were being perfected for an early start."

Further search for information led THE AUTOMOBILE man to establish motor cab service here developed the fact that the Quaker City Cab Company is contemplating adding such a Berliet cab service to its large horse-drawn outfit.

Further search for information led THE AUTOMOBILE man to the Bellevue-Stratford garage, where Manager Lewis gave out the information that within sixty days the Pennsylvania Taximeter Cab Company, recently incorporated in Camden with a capital of \$50,000, would have on the street at least 25 specially designed taxicabs of 24 horsepower and capable of carrying five passengers exclusive of the front seat. These vehicles are now being built at Chester, Pa., by the Hinckle-O'Brien-Lewis Co.

## BRIEF ITEMS OF NEWS AND TRADE MISCELLANY

Up to the time of his death a few days ago, Henry A. Allen, of Shushan, N. Y., could doubtless lay claim to being the dean of amateur autoists. He was 93 years of age, but both drove and took care of his own car. He was as enthusiastic an autoist as many a man of a third of his years.

Canton O'Donnell, writing to a Denver friend from Dresden, Germany, says: "I saw an old two-cylinder Winton here yesterday; one of the '04 models. It looked good to me; just like a letter from home. Running just like the first one I ever saw, smooth as any two-cylinder ever made."

The Arkansas Valley Auto & Transit Company has been incorporated at Las Animas, Col., with a capital of \$25,000, to conduct a garage and general repair shop, and will also undertake the contract of transporting sailors to and from the new naval hospital at Fort Tyon. The new company is open for agencies of both cars and sundries.

Pirelli & Company, the Italian tire makers, who have their New York offices at 296 Broadway, are in a position to state authoritatively that the Zusta car will continue in the New York-Paris, despite all rumors to the contrary. The Zusta has been equipped with Pirelli tires throughout the race, and the makers are confident will bring them in to Paris among the leaders.

The P. & H. Tire Company, 1657 Broadway, New York, has just closed what is thought to be one of the biggest tire deals put through. It is a contract with Norvell, Shapleigh & Company, St. Louis, to take a minimum of 75 P. & H. tubes daily, their average now being 200 per day. The St. Louis house becomes the United States distributors, having the entire territory, except New York and New Jersey.

Coincident with the holding of the Long Island Subway celebration at Jamaica, the Jamaica Motor Car Company will open a new branch garage on Hillside avenue, near the corner of Flushing avenue. A large building constructed especially for the purpose is now nearing completion. It will also contain salesrooms for cars and sundries and complete lines of supplies.

Morton E. Converse, of Winchendon, Mass., the wealthy toy manufacturer, has just returned from a round trip to Washington, D. C., in his new Grout car. Mr. Converse took the car on this 1,200-mile trip right out of the factory and ran the entire distance both ways without having to make an involuntary stop. This is his second Grout and he is enthusiastic over the car's good points.

The Trojan Hydro-Pneumatic Wheel Company, Watervliet, N. Y., has just completed the installation of a set of their hydro-pneumatic springs to one of the 9,000-pound trucks being run in the service of R. H. Macy & Company, New York City. This is the first truck ever mounted on springs of this kind, and as the latter are the only ones of their class on the market the outcome will be looked forward to with considerable interest.

Announcement is made that there will be at least one, and probably two, of the new Hol-Tan cars in the coming A. A. A. Reliability tour this year. The factory in Massachusetts is making good progress on the series of cars now being turned out

and it is expected that cars will not only be on exhibition at the New York salesrooms very soon, but that the Hol-Tan Company will be in a position to make deliveries on orders.

Negotiations were successfully terminated last week for the exclusive use of the Elmore taxicab at the new terminal station in Washington, D. C., and this is but one of the cities in which the two-cycle cab turned out by the Elmore Manufacturing Company, Clyde, O., is rapidly making headway, as Chicago, New York and Boston are also operating Elmore cabs. Within a few weeks thirty of the Elmore taxis will be shipped to Washington.

As the result of the recent visit of two of the English directors, prominent in the affairs of the home company, the Spare Motor Wheel of America, Limited, has reorganized its selling forces. George S. Morrow, who has been located at the New York office, has been sent to take charge of the Chicago branch, and the headquarters of the company have been removed to attractive salesrooms on the ground floor of 236 Michigan avenue, a car with a Stepney wheel in use and a second on the running board being kept constantly ready for demonstrations. As copies of the Stepney spare wheel have already appeared, the company has begun actions against the infringers.

To demonstrate that the present day automobile is built to withstand any kind of usage, no matter how hard, and to prove that the American car can run indefinitely over all kinds of roads, the Premier Motor Manufacturing Company, makers of the Premier car, which has been the official pathfinder in laying out the Glidden Tour route, will start a Premier on Monday, June 1, making a century each day for 100 consecutive days. The car will be under observation by disinterested people. The run is unique and will prove valuable to motoring circles in general. The itinerary will be announced later. The car will not complete its endurance test until the first week of September.

"I find business quite as active as it was a year ago," said A. Atwater Kent, of the Atwater Kent Manufacturing Company, Philadelphia, Pa., in speaking of business conditions in the West. "Most of the larger factories are working full time and over time, to meet the sudden demand occasioned by the early spring, and those makers who have a practice of finishing their cars early are sold out, while others have found it necessary to put through special lots of cars for summer delivery. So far as I could see, the manufacturers who got scared and thought it necessary to curtail their product, are now sorry for it. Instead of cutting down our schedules, we increased them and are now thankful that we did so. We contemplate doubling our floor space in the near future."

In judging the value of tires for big cars, an important factor is the size and quality of the strip of rubber that, in the best makes, is interposed between the fabric, or envelope, of the outer casing and the tread; it is usually separated from the tread by one or two plies of fabric, called the "breaker." The pad of rubber thus intervening between the tread and envelope is called the "cushion," and its function is well described by E. H. Broadwell, of the Fisk Rubber Company, who says: "The cushion

is a sort of shock absorber and distributor, which prevents the blows from stones, ruts, and other obstacles, when hit by the tire, being borne by one or two threads, which would cause them to break and prepare the way, by cutting fellow threads, for a blow-out. In the Fisk heavy car type of tire, a pure rubber cushion of unprecedented size is used to distribute these shocks, so that the whole fabric shares in sustaining them.

### NEW AGENCIES ESTABLISHED.

The Foss-Hughes Motor Car Company, which handles the Pierce-Arrow, Cadillac, and Baker electric cars in Philadelphia, has taken over the agency for the Pope-Hartford from the firm of Noblit & Fassett, which has gone out of business. The Matheson car, which was also handled in the Quaker City by the defunct firm, will for the present remain unrepresented there.

In order to be in a better position to take care of the New York trade, the Hartford Suspension Company, which recently removed its headquarters to 150 Bay street, Jersey City, N. J., has opened a branch office at 212 West Eighty-eighth street, near Broadway, New York City. It will be in charge of Ernest R. Waterman.

### PERSONAL TRADE MENTION.

Roy H. Hagerling, formerly connected with the Central Pennsylvania Automobile Company, Harrisburg, Pa., is now identified with the Motor Car Company, Baltimore, Md., agents for the Thomas and Peerless.

F. J. Schafer, until recently with the Utica Motor Car Company, has gone into business for himself and has secured the agency for the Mitchell line. He has opened a garage and salesrooms at 221 Genesee street, Utica, N. Y.

Robert La Porte, for the past 16 years identified as a member of the selling force of the Hartford Rubber Works Company, has just left that concern to join the sales department of the H. H. Franklin Manufacturing Company, Syracuse, N. Y.

Frederick B. Hart, who has been acting as advertising manager for Thomas B. Jeffery & Company, Kenosha, Wis., has just severed his connection with that concern to accept a similar position with the Excelsior Supply Company, Chicago.

Stacy G. Carkhuff, secretary of the Firestone Tire & Rubber Company, Akron, O., has left for an extended business and pleasure trip to the Coast, where he will remain about a month. J. F. Singleton, advertising manager of the company, is now on the Pacific on a two months' leave of absence and the two will doubtless join forces. His place is being filled temporarily by W. G. Slater, of Cleveland.

George F. Kehew, for many years connected with the Pope Manufacturing Company, and up to recently representing the Wayne Automobile Company in New York, has just gone with the National Sales Corporation, 296 Broadway, New York, but will make his headquarters in Detroit, Mich. Mr. Kehew will devote his time particularly to ignition appliances, such as the Connecticut coils, timers, meter and quick detachable terminals; Buffalo mechanically controlled carbureters; Crown dry-cells; Soot-proof plugs and Pirelli cable, for all of which the National Sales Corporation acts as factory sales agents.

**INDEX TO ADVERTISERS**

Abrams-Mason Co. ....	83	Davies, J. P. ....	84	Kirkpatrick, L. B. ....	57	Progressive Mfg. Co. ....	79
Acetylene Gas Illuminating Co. ....	57	De Luxe Motor Car Co. ....	66	Kissell Motor Car Co. ....	60	Quinby Co., J. M. ....	64
Acme Motor Car Co. ....	66	Detroit & Buffalo Steamboat Co. ....	81	Knox Automobile Co. ....	102	Radio Battery Co. ....	73
Adams Co. ....	66	Diamond Chain & Mfg. Co. ....	61	Kokomo Electric Co. ....	91	Raines & Co. ....	56
Aerocar Motor Co. ....	66	Diamond Rubber Co. ....	96	Konigslog, Otto ....	61	Rainier Motor Car Co. ....	67
Ajax-Grieb Rubber Co. ....	79	Dien, Ch. ....	89	K. W. Ignition Co. ....	103	Rauch & Lang Carriage Co. ....	92
Almy Water Tube Boiler Co. ....	56	Dietz Co., R. E. ....	76	Lavalette & Co. ....	56	Reeves Pulley Co. ....	57
Am. Brass & Alum. Works. ....	61	Dixon Crucible Co., Joseph. ....	68	Lear Automobile Co., Oscar. ....	66	Remington Tool & Machine Co. ....	65
Am. Loco. Motor Car Co. ....	Cover	Dorris Motor Car Co. ....	85	Leather Tire Goods Co. ....	67	Remy Electric Co. ....	57
Amer. Motor Car Sales Co. ....	96	Dover Stamping & Mfg. Co. ....	72	Limousine Carriage Mfg. Co. ....	64	Republic Rubber Co. ....	90
Anderson Forge & Machine Co. ....	61	Duplex Coll Co. ....	68	Lipman Mfg. Co. ....	56	Rex Wrench Co. ....	79
Angier Co. ....	84	Duplex Co. ....	70	Lobe Pump Co. ....	57	Richardson Engineering Co. ....	61
Apperson Bros. Automobile Co. ....	78	Earl Motor Car Co. ....	66	Locke & Co. ....	64	Robinson & Sons Co., Wm. C. ....	94
Appliance Mfg. Co. ....	70	Fcho Horn Co. ....	82	Lockwood Bros. ....	92	Robert Instrument Co. ....	56
Ashtabula Bow Socket Co. ....	64	Eclipse Machine Co. ....	61	Locomobile Co. ....	66	Rock Island Tool Co. ....	89
Atlas Motor Car Co. ....	66	Edmunds & Jones Mfg. Co. ....	57	Logan Construction Co. ....	66	Royal Equipment Co. ....	68-57
Audel & Co. ....	71	Eldredge Electric Mfg. Co. ....	56	London Auto Supply Co. ....	64	Rushmore Dynamo Works. ....	94
Aurora Motor Works. ....	66	Elite Mfg. Co. ....	78	Long Arm System Co. ....	84	Sager Co., J. H. ....	77
Austin Automobile Co. ....	66	Ellsworth, J. M. ....	110	Long & Mann Co. ....	60	Salisbury Wheel Mfg. Co. ....	61
Auto Car Equipment Co. ....	94	Elmore Mfg. Co. ....	101	Long Mfg. Co. ....	78	Samson Leather Tire Co. ....	67
Auto Pump Co. ....	62	Empire Automobile Tire Co. ....	86	Lovell-McConnell Mfg. Co. ....	59	Selden Motor Vehicle Co. ....	70
Auto Time Saver Co. ....	57	Empire State Tire Co. ....	67	Manhattan Screw & Stamping Co. ....	83	Shawver Co. ....	69
Auto & Supply Co. ....	57	Excelsior Supply Co. ....	71	Manhattan Storage Co. ....	56	Shlama Tire Protector Co. ....	71
Autocar Co. ....	93	Factory Sales Corporation. ....	88	Maple City Mfg. Co. ....	72	Smith Mfg. Co., R. H. ....	71
Automobile Blue Book. ....	62	Firestone Tire & Rubber Co. ....	95	Marvel Mfg. Co. ....	92	Spacke Machine Co., F. W. ....	72
Automobile Supply Co. ....	65	Fisk Rubber Co. ....	82	Mason, John A. ....	64	Spare Motor Wheel of Am. Cover	78
Auto-Shine Co. ....	56	Fientje, Ernst ....	82	Mason Motor Car Co. ....	85	Speed Changing Pulley Co. ....	78
Avery Portable Lighting Co. ....	69	Forest City Motor Car Co. ....	100	Masury & Son, John W. ....	88	Speedwell Motor Car Co. ....	67
Baldwin Chain & Mfg. Co. ....	57	Franklin Mfg. Co., H. H. ....	105	Matheson Motor Car Co. ....	102	Spicer Universal Joint Mfg. Co. ....	57
Banker Bros. Co. ....	60	French Mfg. Co. ....	68	Mayo Radiator Co. ....	57	Spittdorf, C. F. ....	83
Barndt-Johnson Auto Supply Co. ....	64	G & J Tire Co. ....	69	Mechanical & Elec. Mfg. Co. ....	74	Sprague Umbrella Co. ....	80
Barnett Drop Forging Co. ....	55	Gabriel Horn Mfg. Co. ....	101	Merchant & Evans Co. ....	84	Springfield Metal Body Co. ....	64
Beaver Mfg. Co. ....	91	Garford Motor Car Co. ....	66	Merritt & Co. ....	64	Standard Automatic Lub. Co. ....	57
Behen-Faught Motor Car Eq. Co. ....	65	Gearless Transmission Co. ....	87	Meyers & Sons, C. G. ....	64	Standard Co. ....	93
Beloit Supply Co. ....	64	Gelszler Bros. ....	56	Mezger, C. A. ....	90	Standard Welding Co. ....	73
Black Mfg. Co. ....	85	Gemmer Mfg. Co. ....	84	Michellin Tire Co. ....	76	Stanley & Patterson. ....	98
Blasier Mfg. Co., M. E. ....	64	General Accumulator and Battery Co. ....	104	Midland Motor Car Co. ....	74	Star Speedometer Co. ....	90
Bliss-Chester Co. ....	56	Gibney & Bros., Jas. L. ....	57	Miller Bros. ....	76	Steam Carriage Boiler Co. ....	57
Borbeln Auto Co. ....	75	Gilbert Mfg. Co. ....	77	Miller, Chas. E. ....	86	Stearns Co., F. B. ....	58
Bosch Magneto Co. ....	89	Goldberg Motor Car Devices Mfg. Co. ....	63	Miller & Starr. ....	64	Stevens-Duryea Co. ....	95
Boston Auto Gage Co. ....	56	Gray-Hawley Mfg. Co. ....	81	Mitchell Motor Car Co. ....	66	Stitch-in-Time Vulcanizer Co. ....	76
Bowers Co., F. E. ....	77	Greenwald Rubber Co. ....	67	Model Automobile Co. ....	66	Streator Motor Car Co. ....	85
Bowser & Co., S. F. ....	61	Grout Auto Co. ....	97	Moline Automobile Co. ....	85	Studebaker Automobile Co. ....	67
Boyle & Co., John. ....	99	Ham Mfg. Co., C. T. ....	75	Monarch Automobile Co. ....	66	Success Auto Buggy Co. ....	67
Brownell Motor Co., F. A. ....	56	Hardy Co., The R. E. ....	65	Moon Motor Car Co. ....	87	Supplementary Spiral Spring. ....	90
Buckeye Jack Mfg. Co. ....	74	Harris Oil Co., A. W. ....	65	Morgan & Wright. ....	80	Swinehart Clincher Tire Co. ....	83
Buckeye Mfg. Co. ....	66	Hartford Suspension Co. ....	65	Mosler & Co., A. R. ....	67	Syracuse Alum. & Bronze Co. ....	88
Buffalo Carburer Co. ....	82	Hatcher Auto Parts Co. ....	78	Moss Photo Engraving Co. ....	93	Thomas Motor Co., E. R. ....	85
Buffalo Portable Bldg. Co. ....	60	Haynes Automobile Co. ....	88	Motor Car Equipment Co. ....	75	Thompson Sons Co., J. P. ....	67
Bullard Specialty Co. ....	65	Healy Leather Tire Co. ....	87	Motor Car Specialty Co. ....	99	Timken Roller Bearing Axle Co. ....	97
Buob & Scheu. ....	64	Helnze Electric Co. ....	68	Motz Clincher Tire & Rub. Co. ....	67	Tray Plate Battery Co. ....	83
Burlington Basket Co. ....	68	Hercules Electric Co. ....	74	Mueller, Albert ....	84	Trebert Gas Engine Co. ....	67
Burrows & Co., E. T. ....	84	Herz & Co. ....	65	Multiple Ignition Co. ....	87	Triple Action Spring Co. ....	83
Cadillac Motor Car Co. ....	66	Hess-Bright Co. ....	75	Muttu Co., L. J. ....	84	Trojan-Hydro Pneumatic Wheel Co. ....	86
Cameron Car Co. ....	66	Hicks Speed Indicator Co. ....	78	Myers Auto Top Co. ....	64	Tucker, C. F. ....	56
Canton Drop Forge & Mfg. Co. ....	61	Hoffecker Co. ....	65	National Auto Accessories Co. ....	57	Turner Brass Works. ....	57
Capitol Auto Co. ....	64	Hoffman, Geo. W. ....	56	National Motor Vehicle Co. ....	100	Two Spot Mfg. Co. ....	72
Carr, F. S. ....	64	Holley Bros. Co. ....	56	Neustadt Auto & Supply Co. ....	88	Tygart Co., E. A. ....	56
Chadwick Engineering Works. ....	68	Holsman Automobile Co. ....	71	Never-Miss Spark Plug Co. ....	57	U. S. Fireless Cooker Co. ....	73
Champion Co., A. ....	61	Hopewell Bros. ....	56	New Process Rawhide Co. ....	83	Uncas Specialty Co. ....	68
Chase-Shawmut Co. ....	55	Hotel Densmore ....	81	Nordyke & Marmon Co. ....	66	Underwood Typewriter Co. ....	68
Chelsea Clock Co. ....	Cover	Hotel Gilsey House ....	81	Northern Motor Car Co. ....	103	Utility Co. ....	82
Clark, E. S. ....	56	Hotel Joyce ....	81	Northway Motor & Mfg. Co. ....	57	Vacuum Oil Co. ....	91
Cleanola Co. ....	69	Hotel Monmouth Beach. ....	79	Nuttall Co., R. D. ....	81	Veeder Mfg. Co. ....	100
Cleveland Spark Plug Co. ....	74	Hotel New Amsterdam. ....	81	N. Y. Sporting Goods Co. ....	61	Walker Bros. Co. ....	67
Coes Wrench Co. ....	52	Hotel Rexford ....	81	Oakland Motor Car Co. ....	111	Warner Instrument Co. ....	104
Comptoir d'Innovations pour Automobiles ....	57	Hotel Tuller ....	81	Oldfeldt & Sons. ....	65	Watt-Detroit Carburer Co. ....	91
Conn. Tel. & Elec. Co. ....	89	Hotel Westminster. ....	81	Olds Motor Works. ....	67	Wayne Automobile Co. ....	67
Conn. Steel & Wire Co. ....	64	Howard Motor Works. ....	66	Pacific Tucking & Mfg. Co. ....	56	Weeber Mfg. Works, C. F. ....	64
Continental Caoutchouc Co. ....	67	Hoyt Electrical Ins. Co. ....	101	Packard Electric Co. ....	57	Weed Chain Tire Grip Co. ....	76
Continental Motor Mfg. Co. ....	69	Hydraulic Pressed Steel Co. ....	61	Packard Motor Car Co. ....	109	Welch Motor Car Co. ....	85
Cook's Sons, Adam. ....	89	Imperial Motor Car Co. ....	66	Palmer & Singer Mfg. Co. ....	67	Western Motor Co. ....	82
Corbin Motor Vehicle Corp. ....	85	Indestructible Steel Wheel Co. ....	67	Parish & Bingham. ....	61	Weston Elec. Instrument Co. ....	87
Corcoran Lamp Co. ....	76	Jackson Automobile Co. ....	66	Parker Mfg. Co. ....	56	Wheeler & Schebler. ....	108
Cornish-Friedburg Motor Car. ....	66	Jeffery & Co., Thos. B. ....	107	Parker, Stearns & Co. ....	82	White Co. ....	112
Correspondence School of Motor Car Practice. ....	66	Jeffery-DeWitt Co. ....	56	Pennsylvania Rubber Co. ....	98	Whitney Mfg. Co. ....	73
Cotta, Chas. ....	64	Jenckel Motor Mfg. Co. ....	70	Perkins-Campbell Co. ....	74	Willett Eng. & Carburer Co. ....	82
Cowles & Co., C. ....	56	Jones Speedometer ....	92	Peugeot Freres ....	61	Windsor Mfg. Co. ....	55
Crown Soap Co. ....	70	Joyce Cridland Co. ....	84	Pfantiel Elec. Laboratory. ....	71	Winship, W. W. ....	80
Cullman Wheel Co. ....	56	Keystone Lubricating Co. ....	Cover	Picrome Hide Co. ....	61	Winton Motor Carriage Co. ....	Cover
		Kimball Tire Case Co. ....	78	Pierce Engine Co. ....	67	Wisconsin Tire Protector Co. ....	83
		Kinsler Bennett Co. ....	73	Pike Mfg. Co. ....	72	Witherbee Igniter Co. ....	93
				Pioneer Brass Works. ....	61	Wyman & Gordon Co. ....	55
				Pirelli & Co. ....	106	York Motor Car Co. ....	67
				Portland Garage Co. ....	57		
				Prest-O-Lite Co. ....	72		

FOR UNMATCHABLE QUALITY BUY

**COES**

STEEL HANDLE MODEL WRENCH

91

91

Look for the name—COES

**THE WRENCH for Automobilists**

High-grade quality in every detail of design, material, workmanship and up-to-date improvement. Excellence with extremely reasonable cost.

- NON-BREAKABLE CASTINGS
- NON-STRIPABLE THREADS
- NON-TROUBLESOME PARTS

**QUALITY**

Through and Through.



70 years splendid reputation worthily maintained right up to the present time as the World's Best Wrench Makers. Write for "Wrench Book" free.

**COES WRENCH CO., WORCESTER, MASS.**

# THE AUTOMOBILE

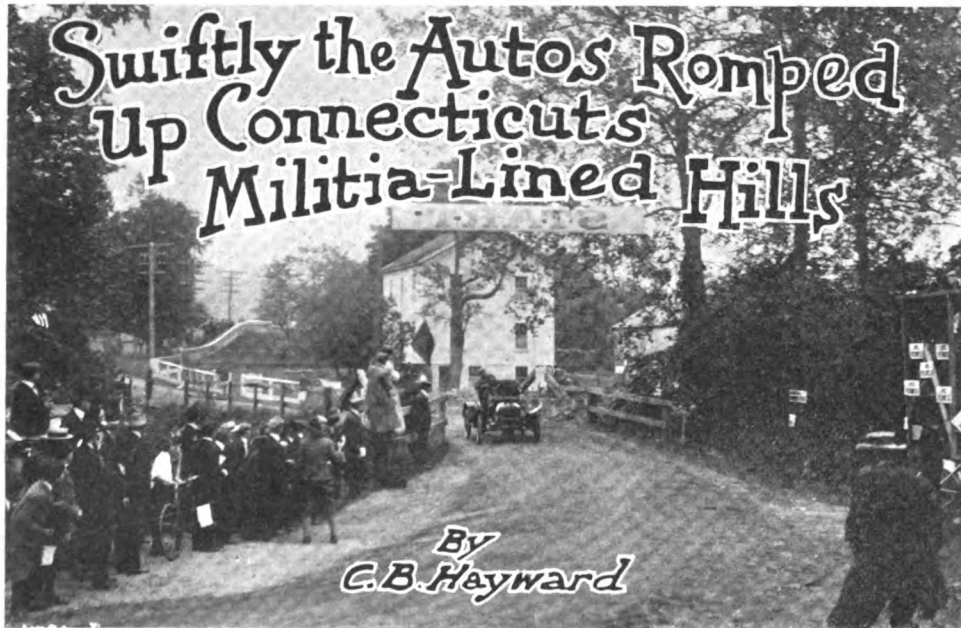

Driver Pollard Ready with His Winning Maxwell Crossing the Bridge at the Start.

BRIDGEPORT, CONN., May 30.—Practically every winner above the small car class took a whack at Tracy's record of 1:24 2-5 for Sport Hill, made last year in a Locomobile, and many substantial slices were taken out of it. Al. Poole, Tracy's former mechanic, lowered it to 1:17 flat, thus making a new low-water mark for the year, in his 50-horsepower Isotta, which accordingly was the winner of the Board of Trade Cup. Arthur Bell's Columbia made the next best time in the free-for-all by finishing in 1:19 4-5, while in the event preceding the free-for-all, which was the wind-up of the program, K. W. McNeil, in a 60-horsepower Stearns, took a few seconds off the record by winning in 1:20 3-5, while Harry Tuttle's 36-horsepower Stoddard-Dayton also came under last year's figures by making it in 1:22 3-5. This was event No. 8 on the well-filled entry list, and was for amateur drivers of gasoline cars, the trophy being the Craufurd cup.

Poole was the first to better Tracy's figures, and as he cut 4 2-5 seconds off them without knowing the hill and its winding turns, it was evident that he would do considerably better when it came to the free-for-all, as events later proved. This was in Event No. 7, in which the Isotta was entered as a stock car in the \$4,001-and-over class for the H. D. Miller cup, but upon examination by the technical committee the car was found to have no lamps or mud guards, and was accordingly protested as not being a stock car within the meaning of the regulations. Poole was permitted to make a time trial, however, doing the distance in 1:20. C. F. Alcott's 60-horsepower Stearns negotiated the hill in 1:23 flat, while K. Swain, driving another Stearns of the same power, made it in 1:25.

Unpropitious weather bade fair to spoil the elaborate prepara-

tions made by Chairman Ralph Sperry, of the executive committee of the Automobile Club of Bridgeport, and his numerous assistants, for the second annual climb of Sport Hill, as there was a heavy drizzle that continued up to within a few hours of the start, and that promised to convert the carefully oiled roadway of the hill into a most dangerous slide. But the clouds held off for several hours, and, although continually threatening a downpour, made as fine weather for such an event as could have been had to order. Nor did the overcast sky throw any damper on the popular interest in what is now regarded as Bridgeport's banner automobile event of the year, for the roads from the city were alive with people as early as 6 o'clock, although the climb was not scheduled to start until two hours later. Thousands poured out to line the course from top to bottom, but so well did Captain Hawes' men of the Coast

Artillery do their work that never for a moment was the road encumbered or the spectators allowed to depart from the side lines, for the khaki-clad men with their guns looked very business-like.

The same efficient management characterized the running of the entire event, so that everything was in clockwork order when Referee A. L. Riker gave the word for the start of the little Maxwell in Event No. 1, which was for gasoline cars listing at \$850 or less. People who have been accustomed to associate the diminutive "two-lunged" runabout with a rate of travel that



Isotta Winning Free-for-All and Bridgeport Cup.





Driver K. W. McNell and His Stearns in the Trial in which that Car Captured the Craufurd Cup.

implied no excess of power for such a thing as overcoming a stiff hill, opened their eyes wide when Pollard dashed over the bridge just before the timer's box, going "all out" and sounding so like the business end of a big racer in the distance that it



Tuttle and His Two-Event Stoddard-Dayton Winner.

only lacked the familiar long drawn out "caar coming" to imagine one's self in attendance at one of the big classics of the year. The lay of the land lends itself admirably to the purpose of a hill-climbing contest, and the various committees in charge



Forbes and Overland Which Won the Second Event.

of the course had taken full advantage of it. The start was located on a level stretch, two or three hundred yards before reaching the elevated stand of the referee and timer, while intervening there was a curve and a sharp dip, ending at the bridge mentioned. This little grade gave the contestants excellent opportunity to get into their best stride in an unusually short distance, so that when they passed under the wire they were in excellent shape to tackle the stiff straightaway grade that stretched up in full view of the starter for fully an eighth of a mile or more.

The course had a natural bank to it on the turn that lay under the wire, and it was evident even to the inexperienced spectator that the driver who negotiated this first turn successfully gained fifths of a second in his getaway. Pollard evidently appreciated this, for he took the little Maxwell around the inside line of the curve as cleanly as if he had not been going more than ten miles an hour, and there was no trace of his passage on the road after he had gone by. Climbing Sport Hill in racing time is no child's play, for it is a big bump—as big and business-like an affair in the shape of a hill as is to be found anywhere in the East, within easy reach of a city, and it has a few singles and a double twist that compel respect and admiration from the man who knows what it is to take a car round them when it is a case of getting there quickly. But Pollard took the Maxwell round them in masterly fashion, and his time of 2:05 2-5 showed what was to be expected of the bigger contestants in the shape of record-breaking. There were originally three entries in this class, but the Buick, entered by H. J. Koehler, had been withdrawn, so the Ford runabout, No. 14, handled by J. G. Hyde, was the second to start. Hyde lost much of the advantage gained on the preliminary spurt by not taking the first curve right, a skid there robbing his attack on the first long grade of much of its ginger, which doubtless accounted for the Ford's poor time of 2:33. This stretch represented a good 10 per cent. grade, culminating in a short sharp rise, followed by a sharp turn to the left, and as the hill is unique in having no "back-dips," every single foot of it being up-grade, the advantage lost there could not be regained during the rest of the climb. With the exception of the dip preceding the start and the straightaway on the level at the top, that lent excitement to the finishes, there is not a foot where speed, once lost, can be regained.

An Overland and Reo were the sole entrants in Event No. 2, for cars listing from \$851 to \$1,250, which made it a second battle of two cylinders versus four, but in this case the result was reversed. T. C. Forbes, driving the 22-horsepower Overland, brought a cheer from the crowd when his time of 1:43 1-5 was announced, Lockwood's 16-horsepower, two-cylinder

Reo not having been able to do better than 2:13 3-5. Forbes had another go at the hill in Event No. 3, but did not do as well, the honors going to Ralph Burman's 30-horsepower Jackson in 1:39 4-5. The 28-horsepower P. & S. Skimabout looked so extremely business-like that great things were predicted for it, but its performance proved a disappointment, Manville not doing better than 1:51.

Harry Tuttle, driving a 30-horsepower Stoddard-Dayton, was the first to make an appreciable inroad into the figures by lowering the time to 1:29 flat in Event No. 5. W. Bogue's Knox was second in 1:32. Tuttle had a second try at the hill in Event No. 6, in which he was the sole starter, C. M. Murphy's Stevens-Duryea "Light Six" having been scratched, but he was several seconds slower. Excitement ran high when C. F. Alcott's 30-60 Stearns proved to be the first to cut under Tracy's record of last year by making the climb in 1:23, while a second Stearns, driven by K. Swain, made it in 1:25.

Then came the event that was expected to furnish an amount of interest, only second to the final free-for-all. The spectators were not disappointed, as K. W. McNeil's Stearns set the lowest official figures so far by making it in 1:20 3-5, while Tuttle bettered his previous efforts in the Stoddard-Dayton by coming home a good second in the contest for the Craufurd cup for amateur drivers, his time being 1:22 3-5. The free-for-all was naturally the crowing event of the day's sport, Poole making the climb in 1:17, the performance of Arthur Bell's Columbia in 1:19 4-5 furnishing considerable of a surprise. The summaries:

**GASOLINE CARS, \$850 AND UNDER.**

No.	Car.	H.P.	Driver.	Time.
1.	Maxwell	12	W. Pollard	2:05 2-5
14.	Ford	15	J. G. Hydg.	2:33

**GASOLINE CARS, \$851 TO \$1,250.**

3.	Overland	22	T. C. P. Forbes	1:43 1-5
4.	Reo	16	W. Lockwood	2:13 3-5

**GASOLINE CARS, \$1,251 TO \$2,000.**

6.	Jackson	30	R. Burman	1:39 4-5
5.	Overland	22	T. C. P. Forbes	1:46

**GASOLINE CARS, \$2,001 to \$2,500.**

10.	Tiley	32	C. B. Tiley	1:54 2-5
-----	-------	----	-------------	----------

**GASOLINE CARS, \$2,501 TO \$3,000.**

15.	Stoddard-Dayton	36	Harry Tuttle	1:29
14.	Knox		W. Bogue	1:32

**GASOLINE CARS, \$3,001 TO \$4,000.**

16.	Stoddard-Dayton	36	Harry Tuttle	1:36 4-5
-----	-----------------	----	--------------	----------

**GASOLINE CARS, \$4,001 AND OVER; MILLER CUP.**

24.	Stearns	30-60	C. F. Alcott	1:23
19.	Stearns	30-60	K. Swain	1:25

**CRAUFURD CUP FOR AMATEUR DRIVERS, GASOLINE CARS.**

33.	Stearns	30-60	K. W. McNeil	1:20 3-5
27.	Stoddard-Dayton	36	Harry Tuttle	1:22 3-5

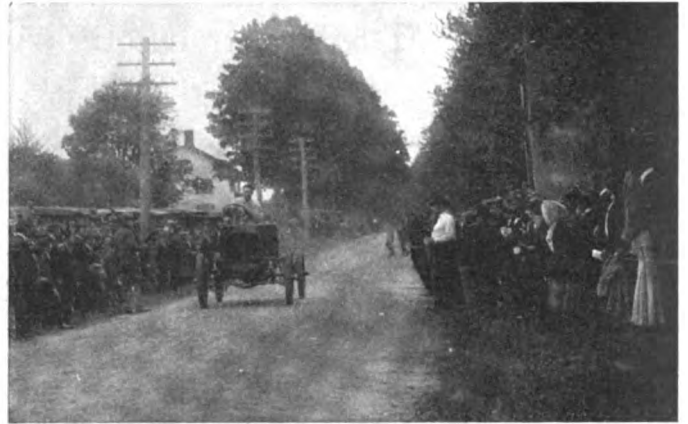

Jackson Which Won in Its Class, and Driver Burman.

**FREE-FOR-ALL BRIDGEPORT BOARD OF TRADE CUP.**

26.	Isotta	50	Al. Poole	1:17
51.	Columbia	29	Arthur Bell	1:19 4-5

The event was run under the auspices of the Automobile Club of Bridgeport, the officials being as follows: Referee,



Miller Cup Winner Stearns and Its Owner, C. F. Alcott.

A. L. Riker; executive committee, Ralph M. Sperry, President Frank T. Staples and Secretary F. W. Bolande; clerk of the course, Gregory S. Bryan; starter, J. B. Lyford; timer, A. L. McMurtry, besides which there were half a dozen umpires.



Patronage of the Lemonade Stands Was Generous at the Foot of Sport Hill Before the Start.

# FAST TIMES MADE BY AMATEURS AT NEW HAVEN

NEW HAVEN, Conn., May 28.—Although yesterday's races up Shingle Hill were mainly for amateurs, some of the professionals were there to lend excitement to the big car events, though it was noticeable that their performances detracted but little from that of their non-professional brothers. As a venue for a hill-climb, the rise that goes by the name of Shingle Hill is one well calculated to tax the skill and daring of any driver, and that there were no accidents of any moment on the twisting turns was considered remarkable. There were some very close escapes, and the manner in which the cars were handled drew cheers from the crowd. This was noticeable in the case of Thompson Dill's masterly handling of the Apperson, the manner in which the Stearns and Locomobile pilots got around the twists, and the skillful avoidance of a telegraph pole by N. B. Whitfield in the Oldsmobile.

In the first event for cars of 200 cubic inches displacement, T. C. Walker took the Ford up in 1:30 4-5, while in the second class, cars up to 400 cubic inches, W. A. Burke, in a Knox, cut this to 1:12 1-5. Harry Tuttle was second in a Stoddard-Dayton, in 1:17 1-5, and Dill's Apperson was third, in 1:18 1-5. In the class for cars up to 550 cubic inches, inclusive, D. B. Brown's Fiat brought the record down to 1:06 4-5; J. S. Joyce's Locomobile was second, in 1:15 1-5; and W. C. Decker's Thomas third, in 1:15 4-5. W. W. Swan, in the Stearns, figured as a winner in the big car event, those having a cylinder volume in excess of 550 cubic inches, by making the hill in 1:07 3-5, his nearest competitor being Joyce's Locomobile in 1:15 2-5, Rus-

sell Lord's Peerless Six and Prossen's Bianchi tying at 1:15 3-5, while L. G. Hall's Stearns followed in 1:18 2-5.

The free-for-all was looked forward to with considerable interest, but did not equal the times of other events, W. W. Swan's Stearns being an easy winner, in 1:10 flat, Burke's Knox being second in 1:11 3-5, and Egbert Lillie's Itala third, in 1:12 2-5. Silver cups were awarded the winners, and in addition D. B. Brown was awarded a gold medal for the fastest time made by an amateur, while Egbert Lillie received a silver medal for second. F. B. Wittemore received the medal for making the fastest time by a member of the Yale Automobile Club, his time being 1:12 4-5, while J. S. Joyce got the medal for second place. The summaries follow:

<b>GASOLINE CARS UP TO 200 CUBIC INCHES CYL. VOL.</b>		
Ford.....	T. C. Walker.....	1:30 4-5
Buick.....	Lee.....	1:35 2-6
<b>GASOLINE CARS, 201 TO 400 CUBIC INCHES CYL. VOL.</b>		
Knox.....	W. A. Burke.....	1:12 1-5
Stoddard-Dayton.....	H. Tuttle.....	1:17 1-5
<b>GASOLINE CARS, 401 TO 550 CUBIC INCHES CYL. VOL.</b>		
Fiat.....	D. B. Brown.....	1:06 4-5
Locomobile.....	J. S. Joyce.....	1:15 1-5
<b>GASOLINE CARS, MORE THAN 550 CUBIC INCHES CYL. VOL.</b>		
Stearns.....	W. W. Swan.....	1:07 3-5
Locomobile.....	J. S. Joyce.....	1:15 2-5
<b>GASOLINE TOURING CARS, FULL EQUIPMENT NOT OVER 550 CUBIC INCHES.</b>		
Thomas-Forty.....	W. A. Maynard.....	1:26 4-5
Stevens-Duryea.....	J. W. Matthews.....	1:32 4-5
<b>FREE-FOR-ALL CARS, ANY MOTIVE POWER.</b>		
Stearns.....	W. W. Swan.....	1:10
Knox.....	W. A. Burke.....	1:11 3-5

## STEARNS WINS 100-MILE AT BALTIMORE.

BALTIMORE, June 1.—On Decoration Day, at Pimlico, the first races under the auspices of the Motor Car Racing Association of Maryland were held. The feature event was a 100-mile championship race, which was won by the 60-horsepower Stearns car, owned and driven by E. L. Leinbach. His time was 2 hours and 47 seconds. In this event the 45-horsepower Acme car, owned by the Acme Motor Car Company, and driven by Jerry Price, went through a fence near the spot where Cedrino was killed on Friday. The summary of events follow:

<b>FIVE MILES.—STOCK TOURING CARS FROM \$2,000 TO \$3,000.</b>		
1. Oldsmobile.....	36	A. L. McCormick..... 6:21
2. Moon.....	32	E. L. Leinbach.....
<b>TEN MILES.—MARYLAND RUNABOUT CHAMPIONSHIP: STOCK TOURING RUNABOUTS OR TOUR.</b>		
1. Pullman.....	40	Robert Morton.....11:45 4-5
2. Pullman.....	30	C. B. Kirkman.....
<b>FIVE MILES.—40.1 TO 60-HORSEPOWER, INCLUSIVE.</b>		
1. Stearns.....	60	E. L. Leinbach..... 5:31 2-5
<b>TEN MILES.—PIMLICO FREE-FOR-ALL HANDICAP.</b>		
1. Stearns.....	60	E. L. Leinbach (scratch) 11:07
2. Pullman.....	40	Robert Morton (23 sec.)
3. Oldsmobile.....	36	A. L. McCormick (45 sec.)
<b>HUNDRED MILE CHAMPIONSHIP.—STRIPPED STOCK CARS OR CHASSIS.</b>		
1. Stearns.....	60	E. L. Leinbach..... 2:00:47
2. Pullman.....	40	Robert Morton..... 2:30:47
<b>SPECIAL EVENT.—FIVE-MILE MOTORCYCLE CHAMPIONSHIP.</b>		
1. Indian.....		H. Matthew Gault..... 6:31
2. Indian.....		W. F. Fisher.....
3. Indian.....		Chick Thomas.....
4. Indian.....		A. L. Bear.....
5. Indian.....		George Lewis.....
6. Indian.....		Harry F. Fisher.....
7. Indian.....		William Rasmussen.....

## MOTORCYCLEDOM TO HAVE A GLIDDEN TOUR.

Motorcycledom fraternity, after automobiledom, is to have an annual long distance tour on the lines of the Glidden Trophy competition. It will be promoted by the Western District of the Federation of American Motorcyclists, and cover a route of some 1,100 miles, with its start at New York on July 6 and its finish at Chicago. The competition will be by club teams. An economy test and a hill-climb will be held en route.

## RECORD ENTRY FOR THE JAMAICA TRIALS.

Indications point to the straightaway time trials on Hillside avenue, Jamaica, to-morrow, being numerically the greatest race meet in the history of the sport in this country. When the entries closed on Tuesday, close to 200 had been made with 51 competing cars. The entrants embrace a large majority of the brands handled in the metropolitan district. The makes represented are as follows: Thomas, Isotta, Mercedes, Fiat, Hotchkiss, Mora, Wolsley, Corbin, B. L. M., Haynes, Ford, Pope-Hartford, Rainier, Allen-Kingston, Pennsylvania, Palmer & Singer, Mitchell, Cadillac, Peerless, Acme, Midland, Meyer, Jackson, Crawford, Stearns, Pullman, Christie, Imperial, Simplex, and the Stevens-Duryea.

The racing will begin at 1 o'clock. There are 24 events carded pretty evenly distributed at a kilometer, a mile, and two miles.

A parade open to all is to precede the racing, participants in which are promised excellent sparking space free.

## BAY STATE'S MEET POSTPONED TO JUNE 17.

Boston, May 30.—The great crowd of people that assembled at Readville track this afternoon for the annual races of the Bay State Automobile Association was forced to go away disappointed, for after waiting more than an hour for the track to dry out the meeting was postponed to June 17. Everything was in readiness for the races, and the track was in excellent condition, when a sudden shower descended. It lasted only a few minutes but that was sufficient to spoil the track for racing purposes, though more rain fell later.

## LONG ISLAND HAS ANOTHER CLUB.

HUNTINGTON, N. Y., June 1.—The large number of autoists resident in this village and vicinity have finally gotten together and have organized the Huntington Automobile Club, of which Daniel M. Gerard has been elected president; F. E. Ruland, secretary, and C. Barclay Ward, treasurer. The club will signalize its existence by holding an automobile carnival July 15.



Willie Haupt in His Great Chadwick Six Climbing "Giant's Despair" in 1:38 2-5.

WILKES-BARRE, PA., May 30.—Unless the American automobile manufacturer and driver cease their efforts to belittle the difficulties of "Giant's Despair," someone will be compelled to put on his thinking cap and suggest a name more in consonance with the facts. To-day's setting sun looked down upon a course strewn with fragments of shattered records. The breaks were none of your puny little chips off here and there, either—they were real damaging fractions, with huge chunks missing, which sadly marred the picturesqueness of the former figures. The course record was thrice maltreated in this way. The first time it was a mere chip—4-5 of a second off the White steamer's 1:49 4-5, made last year. The Stevens-Duryea Big Six, P. J. Robinson up, was the assailant. A few minutes later Willie Haupt, in the Great Chadwick Six, carved off a generous slice of 7 3-5 seconds from the Stevens-Duryea's figures, with a trip up the 6,000 feet of mountain road in 1:41 2-5. And then Haupt, just to show that the Chadwick's performance was not a piece of mere luck, repeated in 1:38 2-5—a three-second chunk this time. When it is recalled that the Chadwick's figures represent a lowering of the best previous gasoline time (Matheson's 1:59 2-5) by an even 21 seconds, and that they are 1 3-5 seconds under the wonderful mark made by Bill Wray on his 6-horsepower Simplex-Peugeot motorcycle last year, Haupt's driving can be characterized as little short of wonderful.

Eight times was the course negotiated under two minutes—thrice by the Chadwick, twice by the Stevens-Duryea, and thrice by a brace of Stanley steamers. There were many regrets expressed that the recent accident to Walter White prevented the White car from competing. Not only did the Wilkes-Barre Automobile Club officials desire to show Mr. White that they were hide-bound sports and harbored no malice as a result of past disagreements, but they wanted him and his cars there, and arranged their program accordingly.

When the first race was called at 8:30, the weather promised rain.

After the Ford had nosed out the Maxwell in the \$850-or-under gasoline class by a matter of three seconds, Jackson's 20-horsepower Mitchell had a walk-over for the \$851-to-\$1,250 gasoline class first prize, just jogging up the mountain in 4:02 3-5. When the third event for \$1,251-to-\$2,000 gasoline cars was finished, it was found that the Type 19 Acme, driven by E. Lenge, with a trip in 2:45 2-5, had made the best time; but the Acme's claim to the first prize has been disputed by W. F. Smith, the Philadelphia Rambler manager, in behalf of his entry, driven by Herbert Bitner, which got to the top with a flat tire in 4:08 1-5. The Ramblerites claim that the Acme Company does not make a \$2,000 car, and that their catalogue fails to show a car at that price. The Committee reserved its decision.

The first real evidence of speed was given in the fourth event, for \$2,001-\$3,000 gasoline cars, when the Stoddard-Dayton "45" negotiated the mountain in 2:14 2-5. The Pennsylvanians endeavored to put in their special Pennsylvania "50," a Vanderbilt Cup car, as a post entry, but the Stoddard-Daytonites, who had made the best time of the day up to that point, put in a most strenuous protest, which was upheld.

After John Dower's Model "O" Corbin "30" had made the trip to the top in 2:45 1-5 in the fifth event—steam or gasoline stock cars selling for \$2,001 to \$3,000—in a sharp shower, time was called to give J. Pluvius a chance to change his mind. Another half hour to allow the course to dry off and to get the tens of thousands of spectators back to their dripping roosts along the side lines, and the game was on once more. As the Corbin had complained of bad skidding on the greasy turns during its wet trip, the officials decided to allow it another trial to equalize matters. But the Corbin stalled just beyond the Mountain House, and first place went to the Thomas-Detroit "40," driven by Oliver Light, with a mark in 2:19 1-5. "Suppose the Thomas-Detroit had done anything slower than 2:45 1-5, the Corbin's first time, who would have been awarded first



Stevens-Duryea Big Six Starting in the Free-for-All on "Giant's Despair."



prize," was a poser handed to an official. "Never cross a bridge until you come to it," was the reply.

A walk-over in the sixth event, for \$3,001-to-\$4,000 gasoline stock cars, was the luck of the Stevens-Duryea Little Six, driven by S. H. Hancock, who sent his car up the mountain in 2:17.

The seventh event witnessed still another walk-over, but it was due to the fact that H. N. Harding, entrant of the Matheson "50," protested his only competitor out of the race for not being equipped with a pan. Referee Morrell read the rules, and reluctantly ordered O. W. Hoffman to take his 30-60 Stearns back to the park. Hoffman said he removed his pan because it rattled, and not to save the trifle in weight. The conditions called for stock equipment, and Morrell could not but decide against the Stearns when the matter had been officially brought to his attention. After the dispute was settled, C. A. Nan jogged the Matheson up the hill in 3:14 2-5, thereby annexing the Wilkes-Barre "Record" trophy.

The real form of the big fellows was first shown in the eighth event, for six-cylinder gasoline stock cars selling for \$2,500 or over. S. H. Hancock led off with the Stevens-Duryea Little Six in 2:08 1-5, and then all of a sudden the huge crowds were electrified by the announcement of a 1:52 flat trip by the Little Six's big brother, driven by P. J. Robinson, from the Chicopee Falls

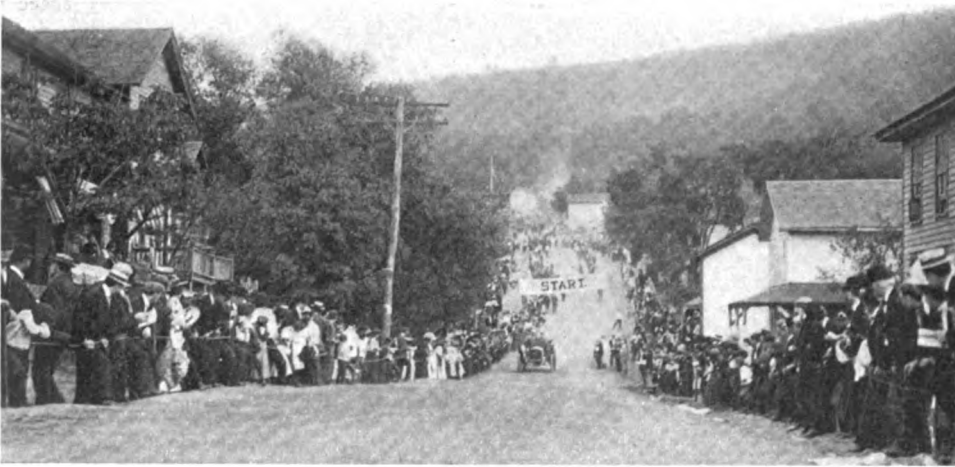

How the Course Was Kept Clear Up the Long Stretch of Wilkes-Barre Mountain.

factory. This smashed the best previous gasoline record by over seven seconds. Willie Haupt followed in the Great Chadwick, but could do no better than 1:59 3-5, due mainly to a much-too-slow start. J. Deatrich finished up the event with a 2:38 1-5 journey in his Matheson, the big Stevens thus capturing the splendid Wilkes-Barre Automobile Club trophy. Robinson came as near as a hair to having a bad accident in this event. Finishing very fast, the crowd beyond the line had not realized how far he would be compelled to go before he could stop. His, it will be remembered, was the first really fast trip of the day. Dashing over the brow of the rise and down the slight decline, the people had to scatter like sheep, and quickly, too, to avoid a bad accident. Robinson worked at his brakes like a madman, and just managed to stop short of the bulk of the jammed-in crowd. It was certainly a close shave, and afterwards, with the assistance of a force of State constabulary, the course was kept clear for quite a distance beyond the finish line.

The event of the day came next—the free-for-all. John Dower and his Model "M" Corbin opened proceedings with a trip in the modest time of 2:11 1-5. The big Stevens Six followed, with the 1:49, which broke the White course record by four-fifths of a second, which announcement woke the crowd to a realization of the possibilities. After the Thomas-Detroit had made the journey in 2:15, "Willie" Haupt got off to a start which opened the eyes of the onlookers. In the previous event he had been unable to attain sufficient speed at the getaway, and his pace when crossing the tape had been comparatively slow.

But this time the car picked up beautifully, and by the time Starter Fred Brand's gun cracked, he was giving those at the start the best exhibition of speed they had seen during the day. Up the first thousand feet of 10 per cent. grade he flew on his second speed (2.6)—he afterward said he had not used his high except in practice—and, rounding the elbow, he threw in this third (3.9), which took hold beautifully without perceptibly lessening his speed, although he was now on a 16 per cent. rise. Without a change, but with his eyes glued to the course, and exerting all his strength to guide his car, he swung around the bad "S" at the Mountain House, and onto the stretch leading up to Prospect Rock, which he passed like a flash. Here he struck the foot of the long 20 per cent. pull to the top—a full 600 yards. But he knew his car and his gears after his toilsome practice of the previous days, and the big Chadwick mounted the stiff slope like a bird and flashed past the finish in 1:41 2-5. When the news of this performance was 'phoned to the start, the huge crowds gave vent to their pleasure in the characteristic American way—they shouted long and loud. The Chadwick was equipped with a full set of Continental tires.

Three additional cars tackled the job before the event was finished, but the glamour of the Chadwick's victory threw their otherwise creditable efforts into the shade. The twin Stanley "30's" both got under the two-minute mark—D. Walter Harper doing 1:59 3-5, and Fred Marriott, of straightaway mile-record fame, two seconds better—but the crowds were hungry for records, and nothing less would satisfy them.

For that reason the tenth event, open to stock chassis, with piston area not exceeding 103.87 inches, and for which Briarcliff models were eligible, fell a trifle flat. In some respects it was the best contest of the day, the cars being more evenly matched than in most of the other events. The fact that possession of one of the three legs of the crack bit of plunder in the prize line—the \$1,000 Hollenback trophy—hung on the result of the race even failed to enthuse the crowds after the wonder-

ful doings in the previous event. The Corbin, the Stevens Little Six and the Stearns all came close to the two-minute mark; the Pennsylvania Vanderbilt candidate, the Thomas-Detroit, and the Pennsylvania stock "50" did nearly as well, while the Matheson kept up the series of poor performances of the native car by a laggish 2:52. The Corbin won out in 2:02 2-5, the Stearns, with 2:04 3-5, nosing out the Little Six for the place by 1-5 of a second.

The crowd set up again when the announcement was 'phoned to the various stations that the Chadwick and a special Matheson would each make a record trial over the course. Haupt was first to face the starter. He asked for and obtained permission to take the Chadwick back of the railroad crossing a hundred yards or so to give the car a chance to gather speed before reaching the ribbon. The scheme worked to perfection, for, taking a terrific bumping as he crossed the double tracks, Haupt had the car at close to the top speed as Starter Brand gave him the gun. Out of sight up the mountain he whisked in a cloud of dust and gasoline vapor. At the successive stations—the Elbow, Mountain House, and finish—'Phoneman Cassidy got reports of his progress, and during the interval which elapsed before announcing the time, a strange stillness fell on the crowd. Although the spectators could not hear what Cassidy said to Announcer Lasher, it knew from his manner that the record had been beaten. "One thirty-eight and three-fifths!" thrilled through the 'phone, and the crowd signalized its appreciation of the unusual achievement in a manner which showed that they fully realized what climbing Giant's Despair in that time meant.

The Matheson's try resulted disastrously. It threw its left front tire on entering the Elbow and came within an ace of skinning off the outer layers of the ten-deep crowd on the inner side of the course. But Ward got his car under control in time to prevent trouble, and came dejectedly down the mountain with the inner tube spitefully slapping the road at each revolution.

The meet wound up with the event for the Quaker City Motor Club members, which was divided into three sections to give the various classes a chance to win. Fred Marriott again scored over his brother Stanleyite in the steam class—1:56 to 2:01 4-5. Bill Longstreth's Maxwell triumphed over "Tommy" Berher's Oldsmobile—2:49 4-5 to 3:14—in the \$2,000-or-under gasoline class. Haupt tried to score again in the \$2,001-or-more gasoline class, but his Chadwick was ditched when a tire went to the bad on the Devil's Elbow, giving Leonard Zengle a walk-over in his Pennsylvania "50," which reached the summit in 2:10 1-5.

While it is somewhat difficult to give comparative figures showing the improvement in time over last year, owing to the fact that the classes were differently arranged this year, the following will indicate a degree of betterment which argues well for the American manufacturer and the American driver:

Event.	1907.	1908.
Record trials .....	1:49 4-5	1:38 2-5
Free-for-all .....	1:59 2-5	1:41 2-5
Six-cylinder, \$2,500 or over.....	2:02 2-5	1:52
Between \$3,000 and \$4,000.....	2:05 4-5	*2:17
Between \$2,000 and \$3,000.....	2:31 3-5	2:14 2-5
Under \$1,000 .....	**2:47	†3:19 2-5

\*Walk-over. \*\*22-horsepower Maxwell. †15-horsepower Ford.

Last year the Chadwick had marks of 2:02 2-5, 2:05 3-5 and 2:07; this year it registered 1:38 2-5, 1:41 2-5 and 1:59 3-5. Last year the Stoddard-Dayton made several trips around in 2:45; this year it won the \$2,001-\$3,000 class in 2:14 2-5, and carried an extra man. In almost every instance where comparisons can be made a marked improvement in time is noticeable, despite the fact that experts considered the course somewhat slower this year.

Many expressions of sympathy were heard for Walter White, and all expressed hopes for a speedy recovery from the effects of his recent accident and for another trial at the mountain next year.

Apropos of next year's climb, there was much discussion of the rumored movement to make the affair a national one by handing it over to the A. A. A. With a most liberal municipal government, which recognizes the value to the city of these annual gatherings and with an ideal course, ideally located, the national body might do worse than assume the management of what will be a sure winner and cannot fail to add to its prestige. Even now the event is considered the blue ribbon event in the hill-climbing line, in the East at least, and manufacturers cherish a win on the historic Wilkes-Barre mountain as they appreciate a victor on no other course. It is already in a measure a national fixture. "Why not," say the advocates of the scheme, "make it such in reality by passing it over to the A. A. A.? It would be like finding money." Why not? The summaries:

Time trials for course record (1:49 4-5, in 1907, held by White Steamer; 1:41 2-5, this meet, held by Great Chadwick).

1. Great Chadwick Six.....	50	W. Haupt .....	1:38 2-5
2. Matheson Six.....	50	C. A. Ward.....	Punctured tire.

**FREE-FOR-ALL, STRIPPED AND RACING CARS.**

1. Great Chadwick Six.....	50	W. Haupt .....	1:41 2-5
2. Stevens-Duryea Big Six.....	50	P. J. Robinson.....	1:49
3. Stanley steamer .....	30	Fred Marriott.....	1:57 3-5
4. Stanley steamer .....	30	D. Walter Harper....	1:59 3-5
5. Corbin .....	35	John Dower .....	2:11 1-5
6. Thomas-Detroit .....	40	Oliver Light .....	2:15
7. Matheson .....	60	C. A. Ward.....	2:18 3-5

**GASOLINE STOCK CHASSES NOT EXCEEDING A TOTAL PISTON AREA OF 103.87 SQUARE INCHES.**

(All Briarcliff models eligible.)

1. Corbin .....	35	John Dower .....	2:02 2-5
2. Stearns .....	30-60	O. W. Hoffman.....	2:04 3-5
3. Stevens-Duryea Little Six.	35	S. H. Hancock.....	2:04 4-5
4. *Pennsylvania .....	50	Alfonso Gentle.....	2:13
5. Thomas-Detroit .....	40	Oliver Light.....	2:14
6. Pennsylvania .....	50	Leonard Zengle.....	2:17 1-5
7. Matheson .....	50	C. A. Ward.....	2:52

\*Protested as ineligible, the car having been specially constructed for the Vanderbilt Cup race.



The Corbin That Won the Stock Chassis Trial.

**SIX-CYLINDER STOCK CARS SELLING FOR \$2,500 OR OVER.**

1. Stevens-Duryea Big Six... 50	P. J. Robinson.....	1:52
2. Great Chadwick Six..... 50	W. Haupt.....	1:59 3-5
3. Stevens-Duryea Little Six. 35	S. H. Hancock.....	2:08 1-5
4. Matheson .....	J. Deatrich .....	2:38 1-5

**FOUR-CYLINDER STOCK CARS SELLING FOR \$4,000 OR OVER.**

1. Matheson .....	50	C. A. Ward.....	3:14 2-5
-------------------	----	-----------------	----------

**GASOLINE STOCK CARS SELLING FROM \$3,001 TO \$4,000.**

1. Stevens-Duryea Little Six. 35	S. H. Hancock.....	2:17
----------------------------------	--------------------	------

**STEAM OR GASOLINE STOCK CARS, \$2,001 TO \$3,000.**

1. Thomas Detroit .....	40	Oliver Light .....	2:19 1-5
2. *Corbin .....	30	John Dower .....	2:45 1-5

\*Allowed another trial owing to course having been set, and stalled at Mountain House.

**GASOLINE STOCK CARS SELLING FROM \$2,001 TO \$3,000.**

1. Stoddard-Dayton .....	45	W. Miller.....	2:14 2-5
2. Thomas Detroit .....	40	Oliver Light.....	2:18
3. Corbin .....	30	John Dower.....	2:24
4. Oldsmobile .....	40	T. W. Berger.....	2:30 2-5
5. Pennsylvania .....	50	Leonard Zengle.....	3:29 4-5

**GASOLINE STOCK CARS SELLING FROM \$1,251 TO \$2,000.**

1. Acme .....	28	E. Lengle .....	2:45 2-5
2. Rambler .....	30	A. H. Bitner.....	4:08 1-5
3. Oldsmobile .....	35	T. W. Berger.....	Stalled

**GASOLINE STOCK CARS SELLING FROM \$851 TO \$1,250.**

1. Mitchell .....	20	R. Jackson.....	4:02 3-5
-------------------	----	-----------------	----------

**GASOLINE STOCK CARS SELLING FOR \$850 OR LESS.**

1. Ford .....	15	A. A. Jones.....	3:19 3-5
2. Maxwell .....	14	C. Fleming.....	3:22 2-5

**OPEN ONLY TO MEMBERS QUAKER CITY MOTOR CLUB.**

Section 1.—For Steam Cars Only.

1. Stanley .....	30	Fred Marriott .....	1:56
2. Stanley .....	30	D. Walter Harper....	2:01 4-5

Section 2.—For Gasoline Cars Costing \$2,000 or Under.

1. Maxwell .....	24	W. C. Longstreth....	2:49 4-5
2. Oldsmobile .....	35	T. W. Berger.....	3:14

Section 3.—For Gasoline Cars Costing \$2,001 or More.

1. Pennsylvania .....	50	L. Zengle.....	2:10 1-5
2. Great Chadwick Six.....	50	W. Haupt.....	Ditched



One of the Pennsylvania Cars That Competed.





Trucco in His Winning Isotta Rounding a Bad Turn.

PALERMO, SICILY, May 20.—Trucco, on an Isotta Fraschini, has won the third annual Targa Florio, Europe's first big car race of the season; Lancia is the eternal second, and Nazzaro, for the first time, has been put out of the running by a sharp skid on one of the mountainous turns followed by the overturning and smashing of his car.

With the exception of a French Berliet, Italy had the 379-mile mountain race with its 1,432 sharp turns for each of the three rounds entirely to itself, French constructors preferring to reserve their forces for the series of 155-millimeter races opening with the Grand Prix. As an all-round testing ground of the value of a car, the Sicilian course selected by Vincenzo Florio for the race which he has originated and brought to such popularity is certainly the acme of perfection. The 93

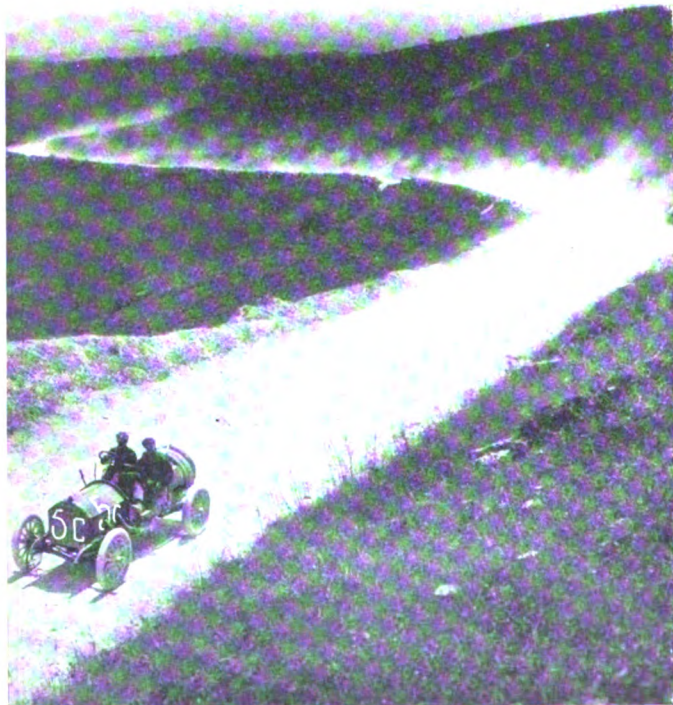

The Berliet on One of the Course's Tortuous Stretches.

miles of road start from the level of the sea, climb around a volcanic mountain, then descend again to the seashore, twisting and winding the whole time at the rate of 15 turns to the mile, giving one sharp swing every 117 yards. No wonder some of the drivers declared they felt seasick.

Trucco, the winner, managed to cut 28 minutes off Nazzaro's last year's record, covering the three rounds in 7:49:25, being an average of 35.5 miles an hour. From beginning to end his 5.1 by 5.9 four-cylinder Isotta Fraschini ran without a stop or attention to its mechanism. It was not the same, however, for the tires, all four of which had to be changed by the winner at the beginning of the third round, owing to the terrible racking effect of the stony mountain road.

Lancia, who started first but finished second, 13 minutes 15 seconds behind the Isotta, really lost his race through bad luck with his tires. On the first round he was running practically dead heat with his companion, Nazzaro; at the end of the second lap he had got first, with Trucco a minute behind and Nazzaro three minutes in the rear. Then the ill luck came along as usual, and the big Italian had to close down his engine three times in succession to change tires. Even with dismantables the operation was not fast enough to catch the speedy and more fortunate Isotta, and Lancia, though the first to cross the finishing line, had again to be registered for second

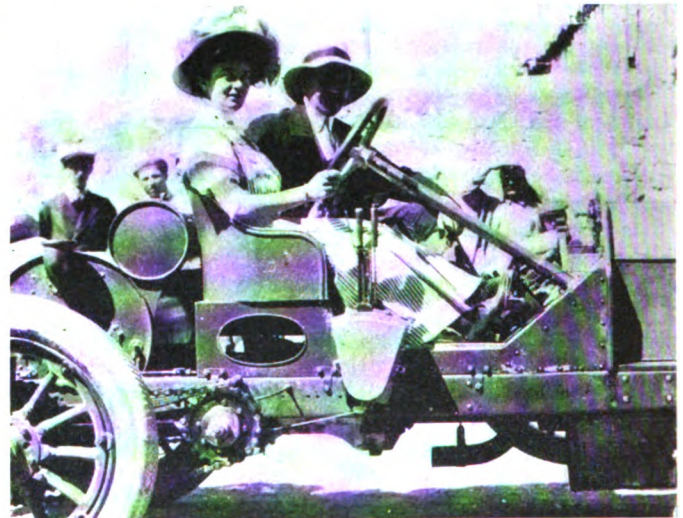

Signor and Signora Fraschini in the Isotta.

prize. There is perhaps a little satisfaction in having beaten Nazzaro's record by the ample margin of 15 minutes.

Ceirano, another son of Italy, took third place on an S. P. A., seven minutes behind Lancia. Porporata, handicapped on the Berliet by reason of his small power, was fourth place by sheer regularity of running, and fifth, sixth and seventh places were taken by Isotta Fraschini, Junior, and Itala, this last named firm taking part unofficially and having its car handled by an amateur.

The six to drop out in the terrible struggle comprised Nazzaro, disabled by reason of a serious skid; Raggio on the S. P. A., with broken valves; Venezia, on the same make of car with a broken wheel; Minoia, on Isotta Fraschini, as the result of a spill; a Zust and a Franco. The official classification is as follows:

1. Isotta Fraschini, Trucco.....	7:49:25
2. Fiat, Lancia.....	8:20:40
3. S. P. A., Ceirano.....	8:30:13
4. Berliet, Porporato.....	8:22:32
5. Isotta Fraschini, Giovanzini.....	8:38:27
6. Junior, Tamagni.....	9:56:08
7. Itala, Pizzagalli.....	9:58:05
Winner's average, 35.5 miles an hour.	
Previous record, Nazzaro, Fiat, 8:17:36.	

Wagner, who was to have completed the Fiat team, was withdrawn, owing to his engagement in the St. Petersburg-Moscow race at the end of the month.







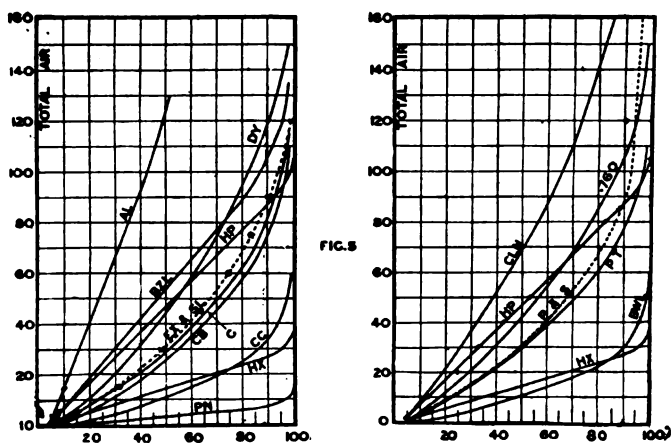

Evaporation Curves Obtained by Experiment.

Hexane and heptane are the chief constituents of petrol, and octane enters also to a greater or less extent into every petrol. The American petrols consist almost entirely of members of the paraffin or saturated series of hydro carbons. Table I gives the properties of the earlier members of this series:

TABLE I.—Properties of the Principal Constituents of Fuels.

Formula	Density at 15 deg. C.	Boiling point	Lower calorific value per liter
Butane	.600	1	—
Pentane, iso-	.628	31	—
Pentane, normal	.626	36	—
Hexane	.674	68.5	7155
Hexahydrobenzine	.760	69	—
Hexahydrotoluene	.772	97	—
Heptane	.688	98	7380
Octane	.719	120	7560
Octane, normal	.707	125	—
Nonane, a	.740	136	7900
Nonane, normal	.722	150	—
Decane	.738	160	8060
Benzene	.884	80.4	9690
Toluene	.871	111.0	—
Ethyl alcohol	.794	78.3	5270
Methyl alcohol	.797	66.0	—

The petrol hydrocarbons are arranged in the order of their boiling points, and it may be noted that the densities and boiling points increase together only in one and the same series. Of the two naphthenes given, which are found in Eastern petrols, hexahydrobenzine has the same boiling point as hexane, but a density of .760 instead of .674, and hexahydrotoluene, with the same boiling point as heptane, has a density of .772, while that of heptane is .688. The density therefore forms no ground on which to condemn a fuel. Industrial alcohol is composed of 90 per cent. of ethyl alcohol (with some water) and 10 per cent. of methyl alcohol or wood spirit.

The hexane, heptane, and octane lines on Fig. 1 and 2 show roughly the composition of the different fuels represented by the curves. They show it roughly only, because certain fuels contain other hydrocarbons than those of the paraffin series. Paraffin is represented by the extreme right-hand curve in Fig. 1, this curve showing only the lightest fractions. I might here call attention to the confusion that often arises between "benzene" and "benzine." Benzene is a definite hydrocarbon, with formula  $C_6H_6$ , and is a coal-tar product. Benzine is a popular name for a certain class of spirits distilled from petroleum, and both names are frequently used for benzol or a mixture of benzene and other coal-tar spirits.

The petrol curves all show the presence of pentane, hexane, heptane and octane, or hydrocarbons of other series with corresponding boiling points. Several reach a higher boiling point than that of octane, and one, the mixture of petrol and shale oil, contains a thick dark brown residue having a boiling point of 273 deg. Cent.

The first thing to find out is the minimum temperature at which it is possible for a fuel to exist as vapor under normal atmospheric pressure. This is obtained from the vapor-tension curve of the fuel, which is a curve giving the minimum temperature at which the vapor has a certain pressure. As it has been found

that the best results are obtained in an engine when the mixture contains about 30 per cent. more air than the quantity theoretically sufficient to completely burn the fuel, I have worked out the results for four mixtures—that containing the right amount of air theoretically, and those with 20 per cent. less, 20 per cent. more, and 40 per cent. more air. The figures are given in Table II.

TABLE II.—Minimum Temperatures at which Fuel Exists as Vapor.

Air	20 per cent. less	Right amount	20 per cent. more	40 per cent. more
Hexane	-14.2	-17.7	-20.6	-24.2
Heptane	7.3	3.6	0.7	2.0
Octane	22.9	19.0	16.0	13.0
Decane	46.1	42.0	39.0	36.5
Benzene	-0.7	-4.3	-6.9	-8.3
Ethyl alcohol	26.5	23.3	20.7	17.8

From this it appears that octane, decane and alcohol cannot exist as vapor under ordinary atmospheric conditions except in very weak mixtures. The large difference between benzene and alcohol accounts for some of the difficulty in using the latter as compared with the former in an engine.

But if these fuels were mixed with the air in the form of liquid at these temperatures, they would not vaporize completely, for in evaporating they reduce the temperature. The fall in temperature due to evaporation can be calculated from the latent heats of the fuel and the specific heat of the air. Table III gives the drop in temperature for the same fuels.

TABLE III.—Drop in Temperature due to Evaporation.

Air	20 per cent. less	Right amount	20 per cent. more	40 per cent. more
Hexane	23.3	19.0	16.3	14.2
Heptane	22.4	17.9	15.0	12.8
Octane	21.5	17.2	14.3	12.3
Decane	18.5	14.8	12.4	10.6
Benzene	47.3	32.2	23.5	20.9
Ethyl alcohol	95.5	76.3	63.7	54.6

Here, again, alcohol in evaporating lowers the temperature twice as much as benzene does. Benzene, too, which, according to Table II, can vaporize at about the same temperature as heptane, produces twice as big a drop in temperature as heptane does.

If the figures in Tables II and III be added together the result gives the minimum temperature which the air must have before the fuel is evaporated in order to completely evaporate it. Table IV gives these temperatures.

TABLE IV.—Minimum Temperature of Air before Evaporation.

Air	20 per cent. less	Right amount	20 per cent. more	40 per cent. more
Hexane	9.1	1.3	- 4.3	- 10.0
Heptane	29.7	21.5	15.7	10.8
Octane	44.4	36.2	30.3	25.3
Decane	64.6	56.8	51.4	47.1
Benzene	46.6	27.9	16.6	12.6
Ethyl alcohol	122.0	99.6	84.4	72.4

With the right amount of air none of the fuels except hexane can be evaporated completely in a cold engine, while alcohol requires the air to be at the boiling point of water for complete evaporation. With 20 per cent. more air, heptane and benzene can be vaporized cold.

Another factor, however, enters into the question, and that is the rate of the evaporation. The time available is very short, and not nearly enough to evaporate the fuels at the minimum

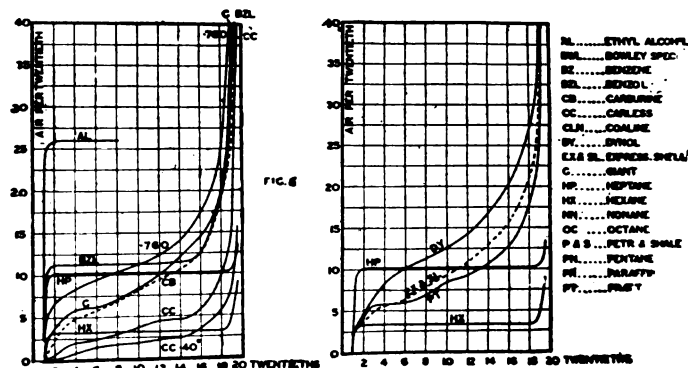

Showing Comparative Volatility of Various Fuels.

temperature. The evaporation of liquid goes on at a slower and slower rate as the space into which it evaporates becomes filled with the vapor.

August's approximate law states that the time required for evaporation is proportional to  $\log \frac{P}{P-p}$ , where P is the maximum and p is the actual vapor pressure at the temperature in question.

The effect of the time required for evaporation can be estimated only by calculating from this expression the different temperatures which will cause the fuels to evaporate in the same time, and by arbitrarily assuming for one fuel, say, hexane, that a certain increase of temperature above the minimum is required to evaporate it sufficiently fast.

I have assumed that for hexane in a theoretically correct mixture the air should be at the normal temperature of 15 degrees Cent.—that is, that 13.7 degrees. must be added to the minimum temperature to evaporate the fuel quickly enough. On this basis I have calculated the additional temperatures to be added in the case of the other fuels to produce evaporation in the same time. Table V gives these temperatures added to those of Table IV.

TABLE V.—Temperatures before Evaporation to Cause Evaporation in the Same Time for each Fuel.

Air	20 per cent. less	Right amount	20 per cent. more	40 per cent. more
Hexane .....	26.8	15	6.6	-2.8
Heptane .....	71.4	58.4	48.7	40.2
Octane .....	104.6	91.4	81.0	72.4
Decane .....	149.3	136.0	126.4	118.4
Benzene .....	81.0	57.3	42.3	34.4
Ethyl alcohol....	181.9	154.3	135.4	120.3

The proportion of these temperatures which represents the time element is certainly somewhat arbitrary, but I think that the figures represent as closely as is possible on theoretical grounds the temperatures which would make the different fuels equally volatile under motor car conditions.

In Fig. 4 these fuels, with the right amount of air, are put on a scale of temperature, and since the more volatile the fuel is the lower is the temperature required for evaporation, the scale of temperature may be regarded to some extent as a scale of volatility, or rather a scale of non-volatility.

**Why "Flooding" Is Usually Necessary to Start.**

Heptane and benzene can, we know from experience, be used readily in engines, even starting from cold. But the temperature of 58 degrees required for their evaporation shows that they do not fully evaporate till the mixture comes in contact with the hot gases in the cylinder. In actual petrols there is always hexane present to facilitate starting, and the fact that it is so often necessary to flood the carbureter to obtain an abnormal quantity of petrol also shows that the evaporation of the heptane is far from complete when there are no hot gases to give the requisite temperature. Anyone who has used a surface carbureter of the old motor bicycle type knows what starting from cold on heptane is like; the "stale" petrol that these carbureters so often produced was simply petrol from which the lighter constituents had been evaporated off.

The benzols of commerce also have certain constituents lighter than benzene, though only in small quantity; but apart from these, starting from cold is comparatively easy, because a much lower temperature is sufficient to give a weaker mixture, but one which will still fire readily. With benzine the temperature diminishes more rapidly as the mixture becomes weaker than it does with heptane, and benzene has the further advantage over heptane that a mixture with 100 per cent. more than the right amount of air is combustible, while heptane is not combustible with more than 75 per cent. more air.

Decane is the lightest constituent of paraffin which is present in any quantity, and from the table appears to be rather more volatile than alcohol. The temperatures of these fuels seem high, but when it is remembered that the residual gases in the cylinder are at 300 or 400 degrees Cent. their evaporation in a hot engine

is explained. All the evaporation though must take place in the cylinder, and there is every chance for the formation of deposit.

Fig. 1 shows that benzene has a higher boiling point than alcohol, while Table V shows that it is far more volatile than alcohol under engine conditions. As we know from experience that it is far more volatile, we may perhaps conclude that the calculations leading up to Table V give a better idea of the volatility than do the boiling points. Unfortunately these calculations are applicable only to pure substances, not to our actual fuels, which are mixtures. A mixture of two hydrocarbons in a certain proportion gives off vapor which also contains the two hydrocarbons in a certain definite but a different proportion, there being more of the lighter constituent in the vapor than in the liquid, and the presence of the lighter constituent enables the heavier to evaporate more readily than it would if alone. A petrol, then, evaporates as a whole, heavier constituents evaporating more slowly than the lighter, but more quickly than they would if not mixed together. The volatility of these complex mixtures is therefore impossible to calculate, even if all the constituents are known, and it can be found only experimentally.

**How the Evaporation Tests Were Made.**

I have worked out a kind of surface carbureter to act as a testing apparatus measuring the volatility of the fuel. The apparatus consists of a graduated tube terminating below in a stop-cock and above in a large bulb, with an opening to the air. Near the bottom of the tube a side tube is introduced and is connected to a foot-bellows. The tube is filled with the fuel to be tested, the quantity being read on the scale. The bellows is then worked steadily, each stroke driving the fuel into the bulb and thoroughly mixing it with the air. The opening from the bulb is so protected that none of the fuel is carried off mechanically with the air. After, say, ten strokes the height of the fuel is read off, the scale indicating how much has been evaporated. After another ten strokes the loss is again ascertained, and so on, till the whole of the petrol is evaporated. The petrol tube is surrounded by a water bath, so as to maintain the temperature constant.

Fig. 5 shows the curves obtained from this apparatus for all the fuels I could get hold of. The abscissæ represent the percentage of fuel evaporated and the ordinates represent the number of strokes of the bellows, or, what amounts to the same thing, the amount of air blown through the petrol. All the points coincide within the limits of accuracy of the method. Above these come the .760 Spirit, and above this Dynol. In the mixture of petrol and shale oil, the petrol and the shale oil seem to evaporate one after the other. Up to 85 per cent. the curve is much the same as the ordinary petrol, then the shale oil begins to show, and no amount of blowing would get off the last 5 per cent.

Fig. 6 is a series of curves derived from the curves of Fig. 5. The abscissæ are successive twentieths of the total volume, and the ordinates are the strokes of the bellows, or quantity of air required to evaporate each successive twentieth—not, as in Fig. 5, the quantity of air required to evaporate all the volume up to the twentieth considered. The ordinates therefore represent, one may say, the volatility of each twentieth of the fuel; the fuel being less volatile the higher the ordinate. In Fig. 6, therefore, the pure fuels are horizontal straight lines, showing constant volatility throughout, and the curves have the same characteristics as the boiling-point curves of Fig. 1. Benzol and heptane have much the same volatility, alcohol being far less volatile. Of course, the amount of air for evaporation cannot be regarded as a *measure* of the quality of a fuel. In the case of a new fuel being put on the market the evaporation test would enable the volatility to be compared with that of the older petrols of known properties, and a value could be got at once placed on it in this respect. If the test should turn out to be of any practical service different apparatus could be standardized by making an evaporation test of heptane, which can be procured cheaply in a fairly pure state, and by thus establishing a coefficient belonging to each apparatus the readings of different apparatus could be made comparable.

# SIMPLIFYING TRANSMISSION OF POWER ON AN AUTO

By L. M. DIETRICH, MEMBER SOCIETY OF AUTOMOBILE ENGINEERS.

NOTHING short of a ponderous volume would begin to suffice to record half the attempts that have been made in the past few years to simplify the method of transmitting the power from the motor to the rear wheels in an automobile. From them all current practice may be said to have settled down upon a system employing a clutch, a change-speed gear, countershaft and chains, or propeller shaft and bevel gear drive at the rear axle. To reduce the number of these essentials and to simplify the

Shaft *A* is loose in the bearings of the side discs, and the wheel *a*, turning on *o* of the support on *A*, simply revolves on the support and imparts no motion to the shaft as long as the two discs *b* and *c* turn at a uniform rate in opposite directions. If one disc is slowed down, the wheel *a* travels with the faster disc, and turns the shaft *A* just in proportion as the speeds of the two discs vary. But in the Dietrich drive both discs are driven positively by gears or friction, as desired. The change of speed is accomplished by making the driving discs concave and swinging the floating disc *a* on its center *o*, as shown in Fig. 2. With the disc *a* horizontal the shaft *A* receives no motion, but, swinging to either position shown, the shaft *A* turns in the direction of the disc on which *a* runs nearest the circumference. If it tips up to 1 it will run with that disc, and if to 2, it runs with the disc 2. This, then, gives both forward and reverse motions to *A*, or allows it to stand perfectly still if *a* is kept horizontal.

Following the application of this principle in the driving axle in Fig. 3, it will be seen that here the motor drives the gear *A* through the shaft from the motor. To reduce the length of the device the convex discs are not parallel, but angular, and the outer discs *D* are driven through the bevels *B* and *C* to get the right surface speed of both discs. All gears and floating discs run on Hess-Bright ball bearings, and the floating discs are controlled by the linkage system shown, a movement of the speed lever or pedal moving the floating disc into any position for forward or reverse or for stopping the car.

To do away with the differential there is a drive for each half of the axle, as shown in Fig. 3. The linkage system is connected to the speed pedal by the center rod and to the steering mechanism by the rods *S S*, so arranged that the turning of the steering wheel drives the wheels at the proper speed for turning the corner, and, unlike the differential gear, each wheel is driven positively whether on slippery pavements or in soft ground. There is also a simple device at *R* which takes care of different roads and grades when desired by acting through the same links to slow down or accelerate, as the case may be, and so utilize the full power of the motor or such portion of the power as desired at all times when nothing is in the way. The device is very simple and is intended to be used principally on motor trucks, with a constant-speed motor and the device set for, say, 10 miles an hour speed on the level. Then, on coming to a heavy grade the speed would come down to perhaps three miles an hour, and would return to 10 miles when the level was again reached, and no matter how much it slowed down, it would always climb the hill at some speed unless the wheels slipped.

The device depends on the friction of the floating disc and the driving discs on the side, but unless these surfaces slip they are positive as gears except, perhaps, for a slight creeping of the surfaces. Compressed cork has been chosen as the material for the bearing surface of the floating discs. Tests show that the dynamic coefficient of friction is 0.35 for cork on cast iron, as against 0.15 for steel on bronze, while for static friction this rises to 0.89 for polished cork against polished cast iron running in oil under a contact pressure of about 50 pounds. The elasticity of cork gives a surface contact instead of a line contact, as with a harder substance, and the fact that it holds well on cast iron and is not affected by oil is in its favor. Then, too, it will be seen that the peripheral speed of the floating disc is constant, regardless of the speed of the driven shaft, so that the driving power is not impaired by slowing down the surface speed.

Briefly stated, some of the advantages of the Dietrich Universal drive, as compared with both the usual type with clutch and sliding gear, and the friction type, claimed for it by its designer, are its unyielding power transmission up to the point of deformation of the material under low local duty. Noiselessness in operation and simplicity and cheapness of construction.

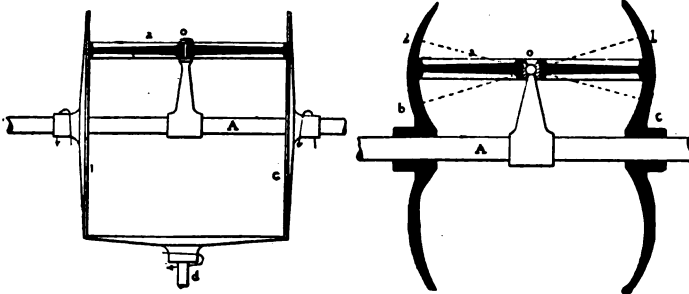

Fig. 1. Fig. 2. Illustrating the floating disc principle and its action.

resultant device has been the aim of countless inventors, but the majority of devices brought forth for the purpose have seldom been worth a second thought, while many involved more complication than they did away with.

The Dietrich Universal Drive axle, which is the invention of L. M. Dietrich, 2507 East Twelfth street, Kansas City, Mo., is quite an exception to the usual attempt along this line and is well worthy of attention. As its name indicates, it is designed to embody all of the essentials in question in a single unit and its range of movement is not confined to a certain definite number of steps, as is the case with the sliding gear, for instance. The basic principle on which it works is neither new nor revolutionary, but the inventor has evolved a plan for applying it to the needs of the purpose in view that is essentially different and that has been very carefully worked out. Before describing the device itself, its principle may be made clear by the small cuts.

Fig. 1 shows a driving device of three discs or bevel gears. *b*, *c* and *d*, *d* being the driver from the motor or other source of power. This will drive discs *b* and *c* in opposite directions.

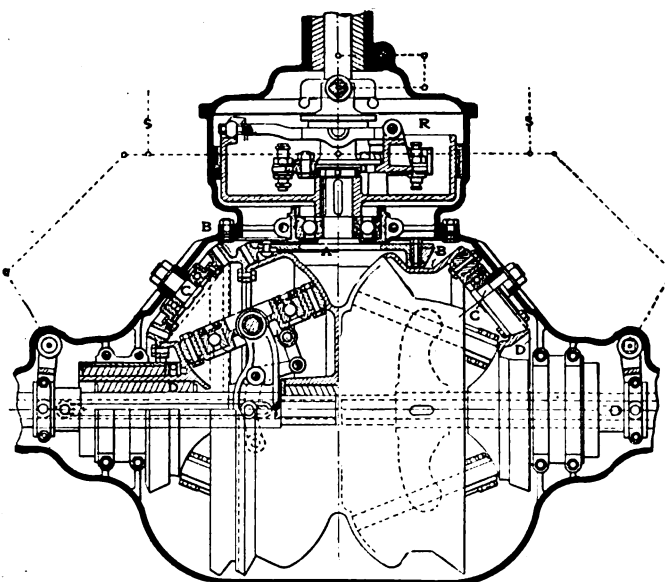

Fig. 3—Dietrich universal automobile driving axle.

## LETTERS INTERESTING AND INSTRUCTIVE

### TIMING A MOTOR WITH WORN VALVES.

Editor THE AUTOMOBILE:

[1,390.]—I recently wrote the manufacturers about my four-cylinder car in regard to the timing. They advise me the engine is timed as follows: "Exhaust opens 5-8 inch before bottom center and closes top center. Intake opens top center and closes bottom center. Engine fires a little less than 3-16 inch past center of compression stroke."

I do not thoroughly understand the time given and shall appreciate your advising me if you can tell me how many degrees past center (flywheel measurement) the exhaust opens, also the number of degrees past center when the engine fires. I can readily understand it about the degrees, but not about the timing as given. The push rods and valve stems have been worn down some, but there is as much as a 1-8 inch difference between them; the former is 3-8 inch diameter, and the latter 5-16 inch. I understand they should be just barely separated. Can you advise me of a way to build them up? Under the circumstances the engine does not develop its full power.

J. G. S.

Louisville, Ky.

It is customary to have the exhaust valve begin to open 30 to 35 degrees on the flywheel circle, in advance of the piston reaching the lower point of its stroke. The intake valve should not close at the bottom center, but should remain open until the piston has traveled slightly beyond on the up stroke in order to aspirate as full a charge as possible. This should be 10 to 15 degrees on the flywheel circle. The ignition should take place exactly at the upper dead center, or close of the compression stroke. The nearer this requirement is fulfilled, the greater will be the power of the motor, as it will then comply with Beau de Rochas' principle of firing the charge at the point of maximum compression. Lag of the various essentials of the ignition system is usually the cause of the ignition taking place late, though the amount you mention is, practically speaking, a negligible quantity where everyday service is concerned. Wear of the valve stems and tappets would be apt to bring about late opening and early closing of the valves, which would be detrimental to its efficiency. To correct such a condition, several expedients may be resorted to. Small pieces of rod of the same size may be welded on to the stems, and then ground down until exactly the right size is reached, or the end of the stems may be drilled and tapped and a piece screwed on to them.

### DIFFERENCE BETWEEN AN H. T. AND AN L. T.

Editor THE AUTOMOBILE:

[1,391.]—Is there any difference between an H. T. and an L. T. magneto? About what voltage does a magneto give? What is gained by letting water drip on the exhaust pipe and having the air intake so arranged that it will draw in the steam. Could a single-unit coil and high-tension distributor be used with a storage battery? How is "prix," as in the Grand Prix race, pronounced?

San Diego, Cal.

H. B. P.

There is considerable difference between a high-tension and a low-tension magneto, particularly where what is known as the true high-tension type of magneto is concerned. On the armature of the latter, there is both a primary and a secondary winding, as in an induction coil. There is also a condenser to prevent sparking at the contact point, a contact maker, or timer, which runs synchronously with the motor, and a high-tension distributor, also running synchronously with the motor. Thus, the machine is a perfectly self-contained ignition outfit in itself, generating the current at low-tension, transforming it and distributing it. In the low-tension magneto there is only a single winding of heavy wire on the armature, and the current is utilized at the voltage at which it is generated. No transformer or high-tension distributor is thus necessary. The voltage of any generator depends upon its speed, but it is nothing uncommon for a magneto's e. m. f. to exceed 100 volts. Steam thus introduced has a cooling effect, but is little advantage. "Prix" is pronounced as if spelled pree, the *x* being silent.

### IS IT THE GEAR-SET OR THE MOTOR?

Editor THE AUTOMOBILE:

[1,392.]—I have a double-opposed engine in my automobile with planetary transmission, two speeds forward and reverse. The low speed for some time has been very much slower than originally, the present gait being hardly one-half of what was formerly developed; it is so slow that unless on a good smooth road it is hard to shift to high speed. Have tried different adjustments without improvement. Have run car with cover plate off of transmission to be sure the slow speed band don't slip; also examined pinion on shaft and find it tight. The planetary gears are in perfect condition. There is no friction in transmission. Can you offer any suggestions for remedying this trouble?

S. F. ALSTON.

Tuscaloosa, Ala.

Are you not barking up the wrong tree in ascribing the fault to the gear-set? The fact that the low-speed members of the gear-set run very slowly, thus causing the car to do likewise, would not prevent you from shifting to the high if the motor is pulling all right, as it is easily possible to start small runabouts directly on the high speed by taking care in making the engagement, so that as long as the car is moving at all there should be no difficulty in making it pick up on the high speed. If your examination has satisfied you that there is nothing wrong with the gear-set, we think it is time that the motor were examined. None of the pinions in a planetary gear-set could become displaced without interfering with the others and making the fact very audible. You will probably find that the motor is not developing its rated output.

### HOW MUCH WILL A PROPELLER PULL?

Editor THE AUTOMOBILE:

[1,393.]—How can you find what a fan will pull, that is, dead weight; its resistance in power of the following size: a wheel 6 feet in diameter with 24 blades, 6 inches at the outer end and 3 inches at the inner or near the center, and set to catch the air at 11-2-inch dip, running at a velocity of 100 revolutions per minute. Weight not to exceed 16 pounds?

SUBSCRIBER.

Antwerp, O.

The only practical way of ascertaining this would be to build an experimental fan and try it on a spring scale. There is more or less data of recent origin on this, but we do not find it available at the moment, earlier data being all of a different nature, i. e., the volume of air that fans of certain dimensions will deliver. We think you have made a mistake in adopting such a number of vanes for the fan, or propeller, as the most successful types have but two or four blades. It is, however, necessary to run them at high speeds, and their efficiency would be practically nil at the speed you mention. Build an experimental four-bladed fan with the vanes so arranged that the pitch may be altered as desired, and run it from 1,000 to 1,500 r.p.m., registering the pull on a spring scale. The weight of the apparatus has no effect on its capacity, but it would be inconvenient to have a heavy propeller on an airship.

### EXPLAINING A PUZZLING LOSS OF POWER.

Editor THE AUTOMOBILE:

[1,394.]—I have an Autocar runabout and last fall experienced considerable trouble with it, due, I think, to the carbureter. I could not start it until I put some gasoline in the cylinder, and after the engine started I would open the throttle and the motor would not speed up, it would make carbureter shots and sometimes would almost stop. I adjusted both the air and gasoline, but could not get it to run smooth. I had to run on intermediate gear most of the time, as I could not get power enough to drive it on direct; the coil seemed to be all right, as I could get a good spark on the plugs. Do you think I should change the carbureter? I have a Schebler Model D. The engine worked fine in the summer. I have recently ground the valves, overhauled it with the exception of cleaning the cylinders (by the way, it is a two-cylinder car), but it does not seem to have its old power, running good for a



quarter to half-mile, and then it makes muffler shots and slows down; then, after awhile, it will spurt up and run as before for quarter to half mile. Do you think the trouble is due to the carbon on piston, or is it the carbureter?

M. ROBINSON.

Daretown, N. J.

We have known a case, exactly parallel to this, to have been caused by feeding an excess of lubricating oil. The car was an old one and the oiler had degenerated to a point where it no longer fed properly, the vibration causing it to empty very quickly at times. The engine was of the horizontal type and the excess oil worked its way into the combustion chamber and found its way to the spark plug points with the result that the motor acted in exactly the way you describe. Cleaning the cylinders out and regulating the oil supply may prove a remedy for your trouble as it did in the one in question.

### ERRATIC ACTION AT SLOW MOTOR SPEEDS.

Editor THE AUTOMOBILE:

[1,395.]-I am having some trouble with my motor and would like your opinion as to the cause, and advice as to remedy. The machine runs beautifully, with plenty of power and speed, and with never a miss with the throttle well open, but when I try to run at slow speed it picks up slowly and fires back through the muffler, indicating that mixture is too weak; when I open the needle valve enough to remedy this, I get black smoke at muffler and missing when I open the throttle, and even then I get an occasional explosion through muffler. My diagnosis of the trouble is that the carbureter float is too low, but I do not want to change it until I am sure this is correct.

S.

Alton, Ill.

Considered purely from the practical point of view and letting theory aside for the moment, there is not half as much real importance to be attached to the level of the float in the fuel chamber as many of the would-be experts would like to have one believe. Take practically any motor that is in fair running condition, and while it is under way shut off the gasoline. In nine cases out of ten, it will continue to run smoothly, and in fact, will run better toward the last on what fuel is in the float chamber, until the latter is practically exhausted, sometimes almost dry. If the float is about 1-16 inch below the level of the spray nozzle in the carbureter of your car, we should not advise tampering with it. Some of the foreign cars have the stems of the float made so that there is a large range of adjustment for the height of the float, holes being drilled transversely through the stem in different directions, so that the float may be raised or lowered by small fractions of an inch, merely by drawing out and reinserting a small pin. But where the float has been placed anywhere below the level of the spray nozzle, as allowed by the adjustments, we have failed to find any difference in the motor's running regardless of the number of changes that were made one way or the other. In giving more gasoline, you doubtless went to the other extreme, as a very slight fraction of a turn of the needle valve will frequently make a very perceptible difference. With the motor running, shut the gasoline off at the needle valve very slowly, until the motor is just getting sufficient to run steadily without missing. To do this, it will be necessary to cut the supply down to the point where the motor actually does miss. Then open it again, equally slowly, until it will run steadily. The fact that there are explosions in the muffler at low speeds is equally indicative of the fact that the mixture may be too rich. See that the auxiliary air valve is working properly.

### INQUIRIES ON A NUMBER OF TOPICS.

Editor THE AUTOMOBILE:

[1,396.]-I have a 24-horsepower, two-cylinder, double-opposed, four-cycle, water-cooled, long-stroke engine. Will a weak battery give as much power to the engine as a strong one, fuel being the same, as long as it doesn't misfire; and does a larger amount of lubricating oil tend to heat or cool cylinders (light-feed oilers)? With good care and a mileage of 1,000 miles per year, how long should the above type of engine give good service, subject to repairs as needed (four-passenger car)? Will the ignition system give an engine more power than batteries? Which is the best, high or low tension? I noticed the trouble of M. F. Parrish of Monroe,

Ind., in your issue of April 9; he does not state whether the engine slows down and stops when he throws the friction wheel to the driver or not. I would like to hear from him again, as I have had similar troubles.

C. A. GOODRICH.

Argentine, Kan.

The weak battery will cause the time of ignition to be delayed more or less, owing to the greater lag in the ignition system due to the failing strength of the current, but so long as the spark is sufficient to fire the motor regularly, experiments show that the difference in the power will be practically negligible. This is disputed by many authorities, but an exhaustive series of experiments carried out to determine just this question seemed to show pretty conclusively that so long as the spark was sufficient to fire the charge in good time, the heat or size of the latter made little perceptible difference. A larger amount of lubricating oil will tend to keep the cylinders cooler, provided the supply is not in excess of the needs of the moving parts, so that the oil is forced up into the combustion chamber, in which case it will carbonize and sooner or later caused premature firing. The magneto ignition system is generally conceded to be far superior to any using batteries and greater power and speed are obtainable from an engine thus equipped. We call Mr. Parrish's notice to your inquiry.

### FIGURING RATIOS OF A FRICTION DRIVE.

Editor THE AUTOMOBILE:

[1,397.]-I wish to convert my car to a friction drive. It has a 12-horsepower engine, 28-inch wheels, sprocket on rear axle, 36 teeth; front sprocket on shaft, 9 teeth; weight of car, 1,500 pounds. What diameter shall I make the friction wheel and what should be the diameter and face of the wood fiber wheel to drive the car 25 miles an hour, the engine running 800 to 1,000 r.p.m. Will the car run just as easy with a larger sprocket on the shaft and a smaller wood fiber wheel? I would like the correct proportions for these wheels.

J. H. KINDIG.

Huntington, Ind.

We should advise making the friction wheel 18 inches in diameter and the driven wheel 12 inches in diameter by 1 1/2 inch face. The width of the latter naturally determines the number of speeds available with a friction wheel of a certain diameter. We should also make the forward sprockets on the countershaft, 12 teeth, instead of 9, leaving the rear sprockets as they are. This will give a 3 to 1 reduction on the chains. Assuming a motor speed of 1,000 r.p.m., and with the driven wheel on the countershaft placed 3 inches from the center of the friction disc, the car should have a speed of 13 to 13 1/2 miles per hour; moving the driven wheel out to a point 6 inches from the center should double this speed, causing the car to travel a little over 27 miles an hour, which, with the necessary losses through slippage, not taken into account in the above, should give the desired speed of about 25 miles per hour. The car will run easier with the larger sprocket, but the driven friction wheel cannot be made small, as it would run too fast and would slip more.

### ADVANTAGES OF TWIN-CYLINDER CASTINGS.

Editor THE AUTOMOBILE:

[1,398.]-I would like to ask a few questions concerning the construction of gasoline motors through "Letters Interesting and Instructive."

1. Why are there more four-cylinder engines (auto type) cast in pairs than separated? What are the advantages and disadvantages?

2. What advantage is claimed of a 3-bearing crankshaft (four-cylinder) over a 5-bearing type?

3. Are there any six-cylinder engines having cranks set at an angle of 60 degrees?

M. H. MURPHY.

Powell, Texas.

1 and 2. The twin casting simplifies matters in a great many different ways, and accordingly reduces the cost of manufacture. There are only two castings to a motor, instead of four; with special machinery each pair of cylinders may be machined at once. It is easier to level and line up two large units on the crankcase than it is with four small ones. The engine as a whole may be made shorter and con-

sequently lighter. The three-bearing crankshaft is shorter, lighter and stronger for the same size motor; or, it may be made very much stronger by putting an extra amount of metal in the cheeks without increasing its weight beyond the point necessary in a five-bearing shaft. The expense of machining is considerably reduced in the three-bearing type; it is easier to align and the bearings themselves may be made larger. We do not know that it has any particular disadvantages not present in the five-bearing type.

3. We do not know of any, but if six-cylinder two-cycle engines were built this would be the logical crankshaft arrangement.

#### AN AUXILIARY AIR VALVE IS REQUIRED.

Editor THE AUTOMOBILE:

[1,399.]—I have a (mixer) carbureter that I think is a little out of order. When the car is standing, the engine will run slow and speeds up all right—appears to—but when the car is running and I open the throttle she does not respond, but will miss. Can you help me out? The mixer has no auxiliary air valve for high speeds. The engine also knocks some when I open the throttle on a hill. The bearings are all O. K.

Warren, Mass.

LOWELL S. ELLIS.

Some means of supplying an additional quantity of air to compensate for the extra fuel drawn through the nozzle at higher motor speeds, is necessary in order to run a variable speed motor satisfactorily. Lack of this provision doubtless also accounts for the knock you speak of, as opening the throttle causes the mixer to supply a rich, slow-burning mixture which gives rise to considerable back pressure on the piston. That is, taking your assumption that the bearings are in good order, to be correct. An examination of the latter may reveal a condition that a casual inspection does not suffice to bring to light.

#### KNOCKING CAUSED BY SLOW-BURNING MIXTURE.

Editor THE AUTOMOBILE:

[1,400.]—I have a 1908 Ford, model S; the valves are clean, pistons have no carbon, and connecting rod is tight, yet there is a dull knock somewhere. I find that when the knock is most prominent, if I adjust the needle valve—sometimes giving it more gas, other times less—the knock ceases and the car runs all right. The carbureter is a Kingston. Will you also tell me where there is anything like a carbureter knock? I have often heard this question discussed, but have had all kinds of answers.

SUBSCRIBER.

The noise you mention is often traceable to an improper mixture, and the fact that you can remedy matters by adjusting the needle valve would seem to indicate that this is the case in the present instance. Unless the mixture be approximately correct, *i.e.*, neither too thin nor too rich, combustion is delayed, and in a high-speed motor such as the Ford the valves do not remain open long enough to permit the burning gases to completely escape. The consequence is, there is still considerable pressure remaining in the cylinder after the exhaust valve closes, and the piston has to work against it. Carbureter popping is common, but we have never heard of a "carbureter knock."

#### WILL A CRANKSHAFT STAND THIS STRAIN?

Editor THE AUTOMOBILE:

[1,401.]—Please inform me as to the relative strength or resisting power of a crankshaft, that is, which part is theoretically subjected to the greatest strain, and if theory and practice coincide? I want to know if the torsional strength of a crankshaft is great enough to allow of the cutting of a ball race on the mainshaft bearing, thereby reducing the diameter from, say, two inches to one and a half inches. Would it stand the strain?

Freehold, N. J.

W. H. PORTENS.

We should regard adopting such an expedient as the practical equivalent of ruining the crankshaft, as it would not be likely to have sufficient capacity to stand the strain very long, particularly as the reduction you speak of amounts to fully 25 per cent. The stresses on a crankshaft naturally increase, in the multi-cylinder motor toward the flywheel end, reaching their summation at the point where the flywheel is attached.

#### FORMULÆ OF VARIOUS AUTO FUELS.

Editor THE AUTOMOBILE:

[1,402.]—Can you give me the formulas for alcohol, gasoline, benzol, benzine (if different than benzol), and kerosene? Will you also give me the formulas after each is mixed with air and burned when perfect combustion takes place? Or the formulas for each burning under atmospheric pressure? Also, if more perfect combustion could be gotten by having several pounds air pressure to mix with the vapor?

Have you the formula for the fuel oil used in large explosive engine and sold by Standard Oil?

H. J. EATON.

Nyack, N. Y.

We regret that the inquiries contained in your letter involve a great deal more research to answer properly than we are able to devote to them. We would refer you to Clerk's and Sorel's works on the subject, the former being the English authority and the latter the French. It may be possible that some subscriber has this data in readily accessible form, and may be willing to supply it for the benefit of the inquirer. Nor do we know the S. O. product's formula, but think it is merely a low grade oil.

#### AVERAGE SPEEDS OF WINNERS IN BRIARCLIFF.

Editor THE AUTOMOBILE:

[1,403.]—Kindly answer this question in "Letters Interesting and Instructive": What was the average speed of the winning car in the Briarcliff race, not counting controls? Different accounts of the race put the speed at from 46 to 49 m. p. h.

Oakdale, L. I.

H. T. CHITTENDEN.

Assuming the course to be 240 miles in length, not including the controls, the average speeds of the first seven to finish in the Briarcliff race were as given on page 598 of THE AUTOMOBILE of April 30. Strang's average, 46.15 miles per hour; Cedrino's, 44.44; Vaughan's Stearns, 43.95; Apperson, 42.24; Seymour's Simplex, 43.37, and Leland's Stearns, 42.85, the last two being unofficial, as the times were not recorded except unofficially. The Bianchi, the fifth car to finish officially, only averaged 40.40 miles per hour. On his best lap, Cedrino in the Fiat made the round at the rate of 49.25, the best Strang did being 47.30 miles per hour.

#### CHANGING FROM ELECTRIC TO GASOLINE.

Editor THE AUTOMOBILE:

[1,404.]—I wish to change power of my Waverley electric to gasoline motor, and am advised you will furnish me with the addresses of firms manufacturing motors.

W. R. SANDERS.

Washington, D. C.

You will not find it advisable to make such a change as you propose, as it involves sufficient work to build a gasoline-driven car complete. Electrics are designed to run at slow speeds and they are very heavy for their size. They are made very high in order to permit of carrying the motors beneath the frame, and the wheelbase is very short—much too short for satisfactory service in a car capable of a speed of more than twenty miles an hour. You will find it much more economical to sell the electric car and invest in new materials. See our advertising columns.

#### AUTOIST'S EXPERIENCE WITH TIRE PROTECTORS.

Editor THE AUTOMOBILE:

[1,405.]—In reply to letter No. 1,352 concerning internal tire protectors, I will give my brief experience. A friend thought he had the tire bogle (?) beaten with just such a band as Mr. Elsemann speaks of—steel discs carefully imbedded in a canvas and rubber belt. I put them in the front wheels (36x3 1-2) with new Michelin shoes and tube that had not gone fifty miles, and had covered about thirty miles when a tire blew out. When I examined it I found a slit wide enough for two fingers and one of the discs protruding. On removing the tube I found many of the discs had chopped out of the belt, and it would have been only a question of a few more miles before the whole tube would have been in shreds. I removed the other tube. It was in pretty bad shape, but not quite as far gone. The "protectors" had been carefully made and carefully inserted, so there were no rough edges to catch, but the action of the wheels had been too much for the tire protectors. The tubes were beyond repair.

H. C. CRESLY.

## REEVES FINDS INDUSTRY IN EXCELLENT CONDITION

FULL time in almost all the factories and in many cases night work in special departments of some 25 factories in the West, is the news supplied by Alfred Reeves, general manager of the American Motor Car Manufacturers' Association, following a two-weeks' visit to Western automobile cities.

"While one likes to view his own industry with eyes of optimism, my view of the Western situation was entirely without prejudice," says Mr. Reeves. "It is difficult for the average man to believe that the automobile business is in such splendid shape, whereas other lines of trade show a marked falling off. It indicates beyond argument the fact that the motor vehicle of to-day, while a luxury for a few, is a necessity for the many.

"At Newark, N. Y., the Mora people are in their new factory and working the full force turning out Mora cars. They have entered a car for the Vanderbilt Cup race. At Rochester, the Gearless people are working on a new 24-horsepower car of the small type to go with their 'Big Six' that was made famous by its work in escorting the round-the-world racers. At Buffalo both the Thomas and Pierce factories are keeping up with their reputation for building excellent cars of the larger type. Buffalo with its big club, is a veritable paradise for autoists. As an indication, I am told that the Rochester club will send 100 cars carrying members to the A. A. A. National Good Roads and Legislative Convention.

"No one denies that Michigan is the father State of automobile manufacture, and Detroit the 'Queen City.' The makers there report Eastern trade to have been a little slack for a couple of months during the Winter, but now coming with a rush. The trade in the West has been good for the past year. It is worth noting that in proportion to population, Iowa has led all other States in the purchase of automobiles during the past three months, according to the books of many makers. The Motorcar Company is working until 10 o'clock at night, turning out the friction-drive Cartercar. The Brush runabout people have their new models well under way and are shipping \$500 single-cylinder wagons every day. The Aerocar people are making big plans for 1909, and so are the DeLuxe. I enjoyed seeing the last 1908 Packard driven through the streets of Detroit.

"As might be expected, the Ford plant is a veritable beehive, turning out runabouts and the new 20-horsepower touring cars, which, by the way, will have the steering wheel on the left-hand side. It is a wonderful production and in keeping with the reputation of Henry Ford. The Wayne people are making great plans for next year, and I was told there were plans for a consolidation of the Northern and Wayne plants, with W. E. Metzger as sales manager. The Cadillac company continues to find an excellent market for their single-cylinder car, while the Thomas-Detroit Company are finding difficulty in getting out enough of

their cars to satisfy agents. Messrs. Chalmers, Coffin and Chapin showed me a new 24-horsepower car which they are getting under way very rapidly and it should be a great seller.

"At Jackson, Mich., the makers of the Jackson car have gone into a factory double the size of their old one; they have erected another factory for motors and also a drop-forging plant.

"No one denies that the Reo proposition is a leader in the automobile trade, and the factory at Lansing is the wonder of all who visit that city. While I expected a good deal, I was not prepared for the changes that have been made during the past six months. About 900 men are being worked, and Messrs. Olds and Peer opened the books and showed me where 803 Reos had been shipped in April.

"Another one of the regular manufacturers that is turning out cars in large quantities is the Maxwell-Briscoe Motor Company, whose big plant in Newcastle, Ind., is now in full swing. The greatest difficulty in Newcastle has been to build homes enough for the workmen who came there for the new enterprise. At Anderson, Mr. Louderback told me they were 168 cars behind in orders for the Lambert friction-drive machine.

"Indianapolis is another leading city for automobile manufacture. The American will continue their underslung racy runabout, while the Marion is devoting its factory to a similar type of car. The Nordyke & Marmon company are meeting with great success in their new air-cooled machine, and Howard Marmon, the designer, told me of some sensational plans for next year. The National as one of the leaders in the big car trade, has had its usual steady business, and so has the Premier. Its work laying out the Glidden tour has brought a lot of attention to the Premier car, and on Monday last they began another test that should attract a lot of attention. It is an attempt to travel a century a day for 100 days, or 10,000 miles in all, to prove the reliability of the auto and its low cost of upkeep. The Overland people have outgrown their factory and are assembling cars and doing a lot of general work in circus tents.

"At Pontiac, Mich., the Rapid Motor Vehicle Company have been snowed under with orders for commercial cars. They are the acknowledged leaders in commercial car manufacture, their products being on the streets of almost every prominent city. The Welch Brothers, notwithstanding the rushing orders of agents, are turning out their cars just as carefully as ever. They are built like a watch. I do not know of any factory in the West where more care is given to each car than in the production of the Welch. A. P. Brush, the designer of the Cadillac, is now at Pontiac, associated with Edward M. Murphy, in the Oakland Motor Car Company, producing a car with two vertical cylinders. The unique method of balancing the motor makes it run almost as smooth as any four-cylinder."

## AS BRISCOE LOOKS AT THE TREND OF DEMAND AND MAKING

"WITH the season of 1908 began what Darwin would characterize the process of 'reversion to type' in automobiles—to lower powered cars," says Benj. Briscoe. "The fad for excessive power has about run its course, and I believe we have seen the last of the road-racing monster. If other signs were lacking, the mere fact that practically every maker of moderate powered cars is oversold would prove this contention. For our own part we won't have a car left in four weeks from to-day, notwithstanding we built 50 per cent. more Maxwells this year than ever before.

"And it isn't all a matter of price either. I can't see that the recent business depression has had any serious effect on the trade; of course many makers reduced their output in the early days of the panic, but even had they built as many as they orig-

inally planned, they still would have sold all they made of moderate-priced cars. Fact is it took a few years to demonstrate to users that the first cost of a car is not the chief item.

"While the user has been learning his lesson in maintenance cost, designers have been refining and simplifying till the 24-horsepower car of to-day is more efficient than the 60 of two years ago. Of course, being less than half the weight—one-third in many cases—it is more economical of fuel, tires and up-keep generally. In the 60-horsepower roadster type of car we have seen high tide in the craze for power and speed. The ebb has now set in and there will be a steady return to sanity, to moderate-powered, light-weight, low-priced cars capable of lawful (which is to say enjoyable) speeds, and evidences of the general trend are to be seen on every hand at the present moment.

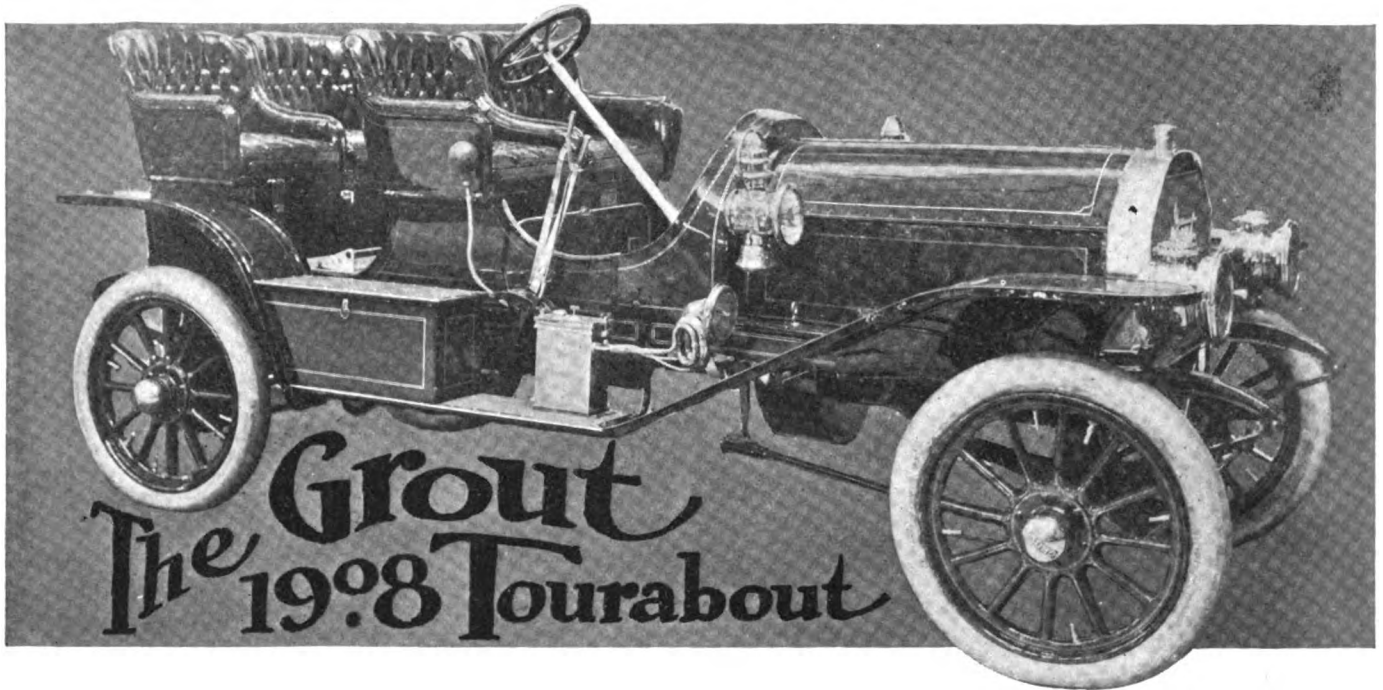

CONSISTENT adherence to features that have been tried out in past models of the same car, rather than radical departures of any nature, characterize the Grout for 1908. The makers—the Grout Automobile Company, Orange, Mass.—have not as yet gone in for building their own motors, but still stick to the Rutenber. This is a four-cylinder, four-cycle type, the dimensions of which are 4 1-2-inch bore by 5-inch stroke, and it is designed to develop its rated output of 35-horsepower at a moderate normal speed. It has given such satisfactory service in the Grout cars turned out in the past that the makers have found no occasion to change. The cylinders are independently cast units with the valve chambers on the left hand side, the inlet and exhaust manifold folds being held in place by common yokes, thus making them easily detachable. The use of separately cast cylinders calls for a five-bearing crank-shaft and the builders of the motor have made unusually liberal provision in this respect, the five bearings totaling 11 inches.

The connecting rods are of the marine type and are made of one-piece drop-forgings of open hearth steel, while the piston pins are also of a special grade of steel and are made of large diameter. The valves are likewise one-piece drop-forgings, while the valve lifts are made adjustable and interchangeable. Drop-forgings are also employed for the timing gears, which are completely enclosed in the aluminum alloy crankcase and run in oil constantly, thus tending to make the motor very silent-running. The cams are made integral with the camshaft and are ground accurately to contour. The pump is of the standard gear type, and is made entirely of bronze, with the exception of the shafts, which are of steel. Every part of the motor is made interchangeable to facilitate replacements and particular attention has been paid to simplifying it to a point where no great amount of experience is required to dismantle or re-assemble its working parts. An instance of this is to be found in the manifolds, mention of which has already been made. Both the inlet and exhaust piping can be entirely removed by loosening four nuts, the motor being distinguished in

this respect by a construction which entirely eliminates the use of gaskets in the joints between the piping and the cylinders.

The synchronous type of high-tension ignition is employed, using a single induction coil mounted on the dash. This simplifies this extremely important essential of the motor to a very great extent, there being but a single coil and vibrator to adjust; while once running satisfactorily, the intensity and timing of the spark are exactly the same in the case of each one of the cylinders. The distributor employed for effecting this is a special type, exclusive with these makers, and consists of a timing device supported at each end by a bronze cap forming a bearing at the top and bottom for the central shaft. There are no frictional surfaces in the secondary member of the distributor, thus eliminating the creation of fine particles of metal, which cause trouble by sticking to the surfaces between the connections and cause short circuits. The entire distributor remains stationary, so that all the wiring is firmly fastened in place, avoiding the tendency to derangement caused by the constant movement of the timer to advance or retard the occurrence of the spark. This is avoided by accomplishing the spark advance through the medium of a sleeve with a spiral slot cut in it and which advances the shaft in the timer ahead of the driving shaft.

It has been developed to a point where it has been found that the motor can be run satisfactorily for long distances without the coil vibrator needing adjustment, and without suffering any damage in the way of burning at the contact points. A much greater mileage is also possible with a single charge of battery.

The essential of lubrication is taken care of by a force-feed oiler located under the bonnet on the right-hand side of the motor and forward, where the oil is kept at a uniform temperature when running. This is an advantage, particularly in cold weather, and it is a feature the adoption of which has been noticeable on a great many of the best-known American cars during the past few years, it no longer being the policy of the best designers to encumber the dash with fittings that are not absolutely needed there.

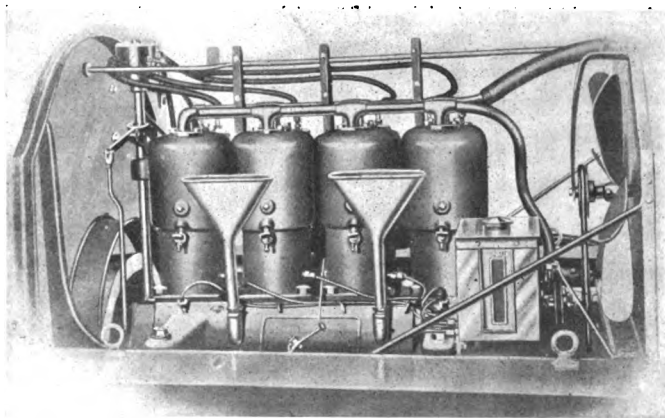

Showing Crankcase Breathers and Oiler, Grout Motor.



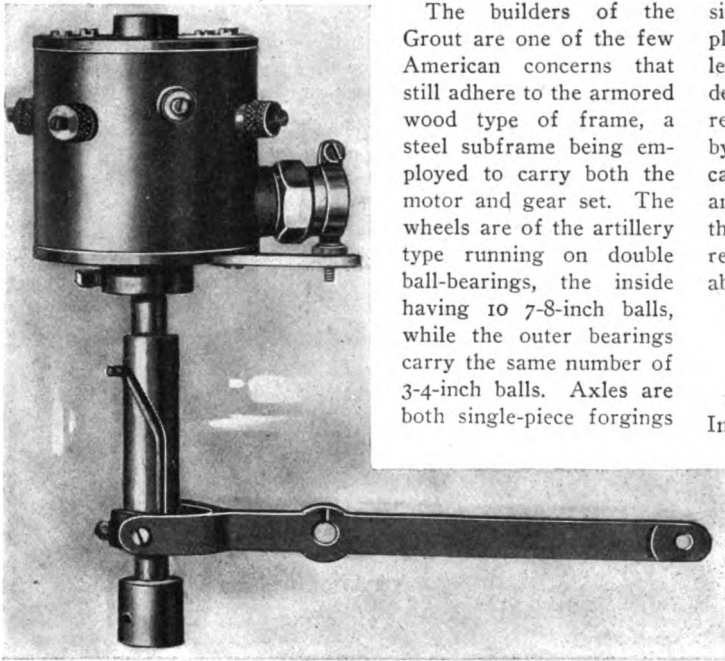

Grout Synchronous High Tension Distributor Showing Advance.

The builders of the Grout are one of the few American concerns that still adhere to the armored wood type of frame, a steel subframe being employed to carry both the motor and gear set. The wheels are of the artillery type running on double ball-bearings, the inside having 10 7-8-inch balls, while the outer bearings carry the same number of 3-4-inch balls. Axles are both single-piece forgings

sis, a seamless pressed steel tank of cylindrical section is employed as a fuel container. This is mounted about midway the length of the chassis so as to come under the front seats and is designed to feed to the carburetor by gravity, its location with regard to the latter being such that the feed is not disturbed by any angle which the car can assume on a grade. It has a capacity of 14 gallons. Control is by means of the usual spark and throttle levers mounted on a stationary sector placed over the steering wheel. Two models are being listed for 1908, the regulation Grout touring car and the Grout four-seated tour-about, an illustration of which is given here.

### FRONT DRIVING OF AUTOMOBILES.

Several interesting papers have been read recently before the Institution of Mechanical Engineers (London) on the subject of front driving as applied to electric, steam and petrol vehicles. The main advantage of the front-wheel drive undoubtedly exists in the fact that the dangers of side-slip are reduced to a minimum. A long, narrow, rectangular block of metal, when moved over a raised surface by imposing a single force pushing at its back, is quite uncontrollable as regards the direction it takes. In this case the surface, reacting on the imposed force frictionally, has a greater effect upon the movements of the metal block than the applied force itself. In short, by applying power to the

back of the block, behind the center of gravity, the movements of the block must be erratic. On the contrary, if the block of metal be pulled from the front over the same surface, a straight course is perfectly feasible. In dealing with sharp turns there is not much to choose between pulling and pushing. There is no doubt, however, that for traffic purposes, the front-driven car is much to be commended. Corners are not taken at high speeds in towns, and in every other respect the stability of this type of car on the most greasy surface is unquestionable.

Dr. Hele-Shaw related some very interesting facts dealing with experiments which had been carried out by the Krieger Company at their garage in Gillingham street. It appears that a surface composed of soft soap was prepared, and two electric cars, front and rear driven, were tested on this surface, proving beyond question that the non-skidding properties of the front-driven type were extraordinary. Granted an efficient transmission and correct distribution of weight, the front drive, as applied to public service vehicles, should meet with undoubted success on pleasure vehicles, as well as for commercial use.

For steering, a gear of the worm type is employed, the wheel being a one-piece bronze spider, on which is mounted the wood rim. Spring connections are provided to take up all shock and jar in the steering gear and provision is made for adjustment in the shape of cone bolts used in the connections, so that any back can be immediately corrected. The wheelbase is 115 inches and the tire equipment is of the clincher type, purchasers being given an option on any standard make of tires. As will be apparent from the accompanying illustration of the complete chas-

sis, a seamless pressed steel tank of cylindrical section is employed as a fuel container. This is mounted about midway the length of the chassis so as to come under the front seats and is designed to feed to the carburetor by gravity, its location with regard to the latter being such that the feed is not disturbed by any angle which the car can assume on a grade. It has a capacity of 14 gallons. Control is by means of the usual spark and throttle levers mounted on a stationary sector placed over the steering wheel. Two models are being listed for 1908, the regulation Grout touring car and the Grout four-seated tour-about, an illustration of which is given here.

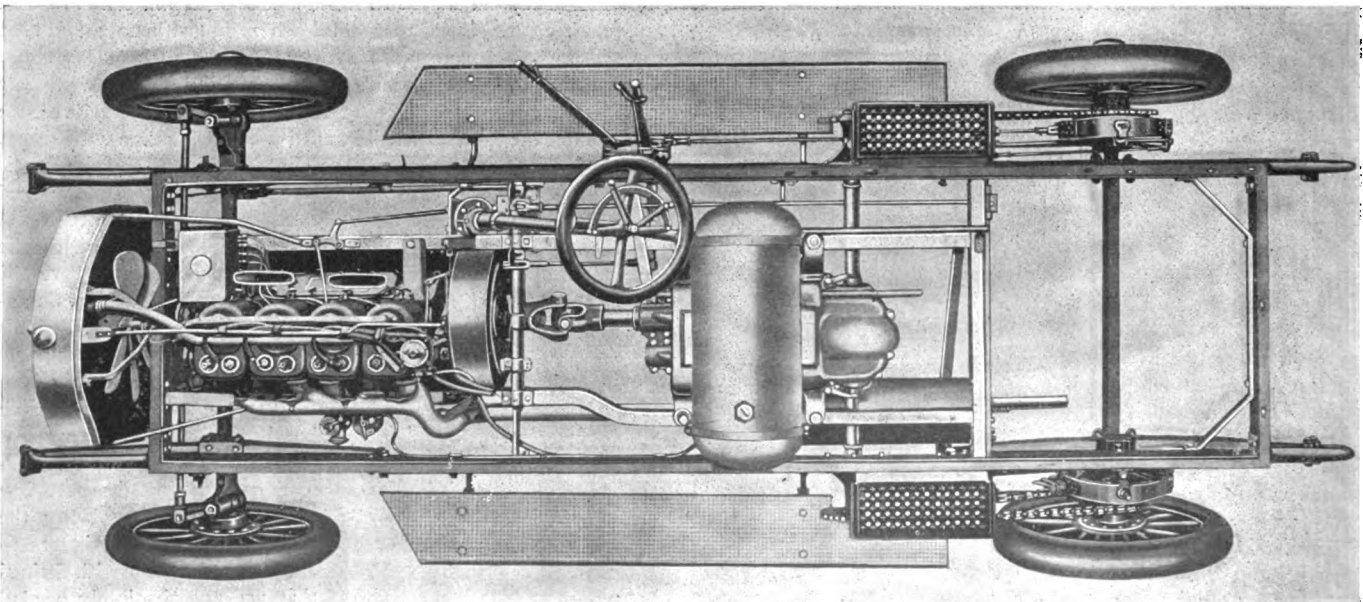

Plan View of Grout Chassis for 1908, Illustrating Convenient Arrangement of Essentials.



Veteran Duryea's Latest Type of Buggy Auto.

### DETAILS OF NEW DURYEYEA "BUGGYAUT."

After seventeen years' experience in building automobiles, Charles E. Duryea, who can well lay claim to being the dean of the profession in this country, has returned to his first love, so to speak, by bringing out a buggy type of automobile with the euphonious title of the "Buggyaut." Although this is really a return to the first principles in many ways, Mr. Duryea's first productions were of the high-wheel type of "horseless carriage," it also embodies a number of radical departures from its first prototype of the early '90's. An air-cooled, two-cylinder, two-cycle motor has been adopted as the power plant, the cylinders being placed almost horizontally under the rear of the body and just slightly forward of the rear axle. The cylinders face forward and are cooled by integrally cast flanges, the flywheel being placed between them. To increase the cooling effect, the motor is inclined at an angle of 15 degrees from the horizontal, and with its two 3 3/4 by 3 3/4-inch cylinders, it is rated at 10-12 horsepower.

A separate muffler is fitted to each cylinder, and as they are large in size and efficient in action, the result is a very quiet-running buggy. The entire power plant is supported on a three-point suspension, and drives by means of extensions of the crankshaft of the motor and small grooved pulleys to large internally grooved rings bolted to the inner faces of the driving wheels. In fact, the method of transmitting the power is one of the most distinctive features of the car. The method is an old one in machine shop practice, having become familiar through long usage on tumbling barrels in foundries, hoisting drums and the like, though for that matter Mr. Duryea states that there is not a single new thing on the car, everything involved in its construction having been thoroughly tried out by years of usage in other fields.

The driving wheels are mounted directly on a dead axle of square section steel and a differential is dispensed with. To obtain the compensating action of a balance gear, an eccentric is fitted to the steering post. When the latter is turned to send the car round a corner, this eccentric shifts the point of the subframe to the inner side while rounding the corner, thus releasing the inner grooved roller from engagement and permitting the outer wheel alone to drive. These grooved rollers are of hardened steel, while the large driving rings are of soft iron, thus giving a good coefficient of friction and minimizing the wear, owing to the ample surface presented. The whole power plant is strongly trussed, binding it together as a solid unit with a three-point type of suspension.

Ignition is of the high-tension type, by means of coil and batteries, the timer and distributor being located in the flywheel of the motor. Another distinctive feature of the latter is the means of starting, which is accomplished from the seat by

means of a pull-up handle connecting with the flywheel by means of a cable. Pulling the handle quickly as far as it will come serves to turn the motor over several times, and the operation may be repeated as often as desired, by merely letting the device resume its normal position after each trial.

The wheels are 36 inches in front and 42 inches in the rear, and are shod with 1 1/4-inch solid tires. The forward axle is a 1-inch I-beam, while the rear is a 1 1/4-inch square axle, the wheels running on ball-bearings. The wheelbase is 80 inches, and the tread standard, though the latter will be varied to order. Steering is by cross-lever and post supported on side bar, the steering pivots being inclined and all points made adjustable. The brakes consist of grooved iron shoes making engagement with the driving rings. They are operated by a pedal, and the latter, together with the change pedal, located at the rear of the footboard instead of forward, as customary, constitute the only pedals employed. The car is usually designed to make a maximum speed of 20 miles an hour, though this may be varied by altering the size of the grooved rollers. The weight, all on, is 850 pounds, 60 per cent. of which comes on the rear wheels. The body equipment is of the regular buggy type, as will be apparent from the accompanying photograph, although a jump seat in the rear is also provided, the price with this equipment being \$750. Full elliptic springs fore and aft are employed and they have been made of ample size to carry the weight. It will be noted that the specifications of the car meet the ideas of many who wish to see a two-cycle, friction-driven combination.

### NEW MODEL ADDED TO THE MOON LINE.

What may be most appropriately termed a between seasons' model has just been added to its line by the Moon Motor Car Company, St. Louis, Mo. It is officially known as "Model D," and is a seven-passenger car on a 121-inch wheelbase. The construction and design throughout follow the same standards as those which characterize the Moon product this year. The neat and attractive lines of the new model are strikingly apparent in the head-on view presented by the accompanying photograph.

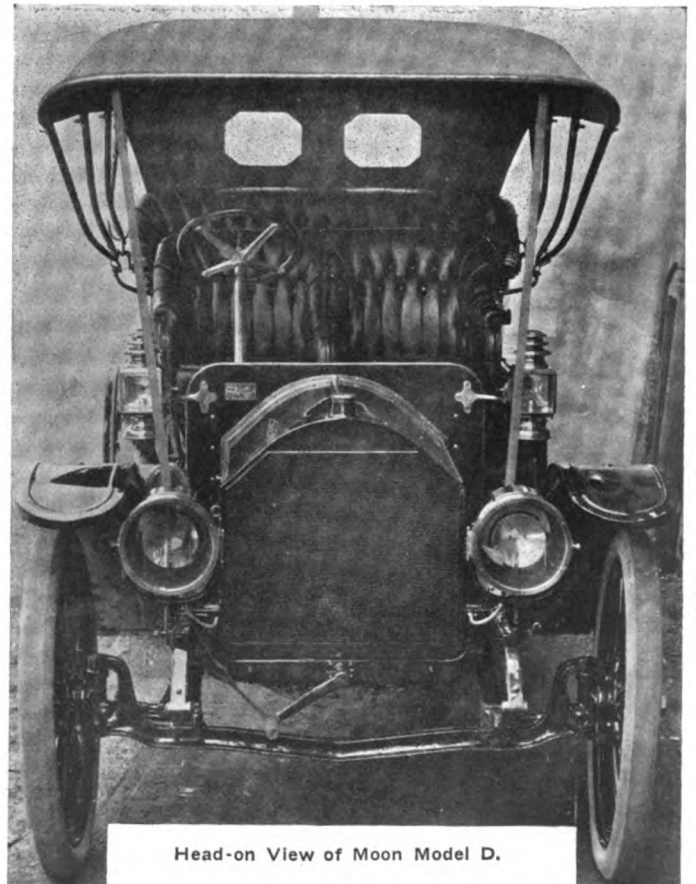

Head-on View of Moon Model D.

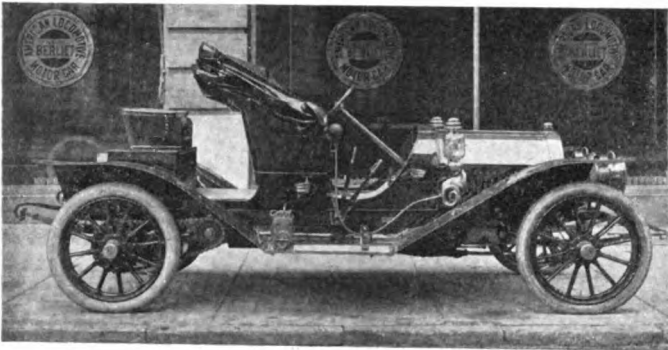

Specially Designed Berliet for Long Distance Tour.

### BERLIET SPECIAL THREE SEATER FOR TOURING.

Runabouts are not generally looked upon as the ideal type of car for a long tour, although what has come to be known as the "touring runabout" has come into vogue within the past two years and has become deservedly popular, owing to its light weight as compared with the regulation type of touring car, as well as the greater ease with which it can be handled. S. L. Schoonmaker, well-known through his connection with the steel industry, has just designed a special body for this type of car. It is intended for the accommodation of himself and Mrs. Schoonmaker, and will be used on a tour of Europe. This special body has been designed for an American Locomotive Auto Company's standard 40-horsepower chassis, on which it is shown mounted in the accompanying photograph. One of its most striking features only becomes apparent upon a little investigation, and that is the unusual amount of storage room provided, as well as the ingenious type of hood that has been designed for the forward seats. There are large drawers under these seats, while under the rumble is a capacious storage box, and yet there is room enough for a trunk back of the rumble seat, without the necessity of employing a trunk rack. It should be an ideal two-person touring outfit.

### PEERLESS BRINGS OUT CLOSE-COUPLED SIX.

Body design would appear to be much the same regardless of the type of car, and even the owner of the big six-cylinder who has power and to spare is not overanxious to tote around with him any more weight in the shape of a body than is actually necessary to accommodate the number he had in view when becoming the owner of the machine. This probably accounts for the Peerless "close-coupled" six-cylinder car shown in the accompanying illustration and which recently became the property of a prominent resident of Akron, O., the "tire city." The use of this type of body on a large car has the great advantage of bringing its entire seating capacity well between the axles and quite a distance forward of the rear axle, which contributes very largely to the comfort of the passengers in the tonneau. This is also possible without giving the car an unusually long wheelbase.



"Close Coupled" Body on a Peerless Six-cylinder.

### FEATURES OF THE CLARK STEAMER FOR 1908.

In numerous ways the Clark steamer is distinguished from others of its class in the steam field, although, as will be seen from the accompanying illustration, its external appearance has been made to conform to that of the standard type of car, whether its power be steam or gasoline. The Clark has been on the market for several years and is manufactured by Edward S. Clark, 242 Freeport street, Boston, Mass. The power-plant consists of a four-cylinder opposed, horizontal, high-pressure steam engine located transversely underneath the frame, so that all valves and other parts are very accessible. All the working parts of the engine are thoroughly protected against the dust and dirt of the road. Lubrication is positive and plentiful, and with the large bearing surfaces provided wear is reduced to a minimum and but little attention is required under ordinary running conditions.

Owing to the high temperature at which the superheated steam is used, poppet valves are employed, a great advantage of this type being found in the fact that where the cylinder becomes



Four-seated Runabout Type of Clark Steamer for 1908.

flooded through carelessness or otherwise, the valves will be lifted from their seats, thus protecting the working parts of the engine from damage. Valve operation is exactly the same as on a gasoline motor, the camshaft and its cams being designed to give all changes of cut-off and reverse, and insuring better economy of fuel than is possible with the slide valve. The generator, which is of the flash type, is placed forward under the hood, while just forward of it is the condenser, in the same location as the radiator of a gasoline car, this arrangement being original with the Clark.

All changes of speed are controlled by the throttle, which is placed above the steering wheel, while the adjustment of the combined fuel and water pump is controlled by a wheel placed below the steering wheel. This allows the operator to make all necessary changes in the amount of water fed to the boiler, in order to meet varying conditions of roads and grades, the generator only making steam as fast as it is used. The adjustable water pump is placed on the footboard, where it is easily accessible, and the valves can be readily removed. The pump plungers have a varying stroke ranging from zero to full capacity, but all the fuel and water are displaced from the body of the pump every time, preventing air from accumulating there and deranging it. The varying stroke of the pump is effected by moving a block on a quadrant operated by a worm, the position of which is easily controlled by the hand wheel on the steering column. The steering wheel can be thrown into a vertical position, thus locking the throttle valve and making the seat more accessible.

Two change-speed gears running on Hess-Bright ball-bearings are provided, the pinions being of chrome nickel steel, a bevel gear drive by propeller shaft connecting the engine and rear axle. The wheelbase is 110 inches, and the tread standard, while the tire equipment consists of 36 by 4-inch tires on all four wheels. The tonneau is large and roomy and the car will carry seven. It lists at \$3,500, while a roadster model with either two or four-seated body lists at \$2,500.

### PREVENTS UNAUTHORIZED USE OF A CAR.

One of the earliest abuses that sprung up in connection with the keeping of automobiles in garages has been their unauthorized use by the chauffeur, and it is safe to say that this abuse is still very frequent to-day, and is, moreover, responsible for a very large percentage of the accidents that happen. In fact, it is safe to say that a majority of the automobile disasters have happened in cases where the chauffeur has had the car out surreptitiously with a few friends of his own choosing, before

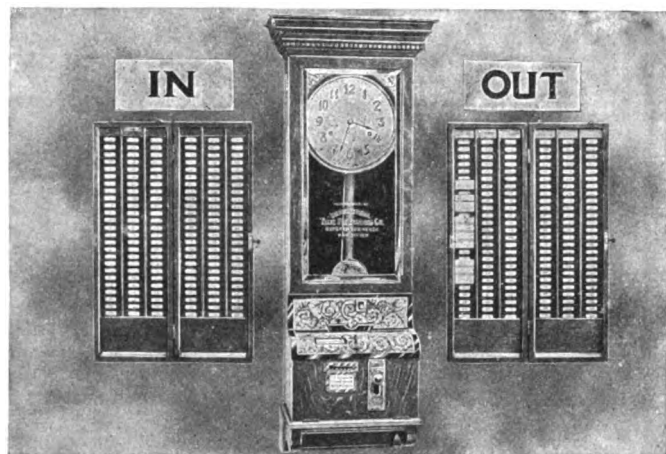

Time Recording System Designed for Garage Use.

whom he found it necessary to indulge in reckless driving. The result is that the car owner is given considerable undesirable publicity in the newspapers, beside which he has to foot the repair bill and the garage keeper has an unpleasant quarter of an hour explaining why the car was out.

To avoid such a state of affairs, numerous systems of checking the movements of cars in a garage have been devised, but with few exceptions they have been found lacking in one respect or another. To overcome such faults, the International Time Recording Company, Endicott, N. Y., has perfected a system whereby a car cannot be taken out of the garage without an automatic record of the exact time being recorded. An International card recorder is placed in the most convenient location overlooking the exit and entrance, while alongside it, two card racks, numbered from 1 to 200, are placed, respectively labeled "In" and "Out." Cards with from 6 to 18 registration columns for each day are placed in the "In" rack, each car being given a recorder number. When all the cars are in the garage, all the cards are in their respective pockets on the "In" rack.

Whenever a driver presents an order to take a car out, the foreman of the garage receives the order, and when the car comes to the exit, the numbered card of the automobile is taken from its rack, the time recorded in an "Out" column, and the card placed in the "Out" rack by someone authorized to allow cars to go out. On its return, its time is recorded in an "In" column, and the card transferred to that rack, a copy of this record being furnished the owner each week so that he knows exactly when his car has been taken out of the garage and when it has been returned. In the garage itself a glance at the rack shows at once exactly what cars are in or out.

Many of the large garages in cities have installed this system of checking cars, and in addition use an International card recorder to register

the arrival and departure of employees and to record the exact amount of time spent on repair jobs, this latter system being a great preventive of disputes over the time expended on this work. Each man is given a job card when he begins work on a car, and he rings "In" the moment he begins work, and "Out" when he finishes. The card is a voucher of the time spent and is also a guarantee to the garage keeper that the time was actually put in on that job, for as soon as one is ended the mechanic must report to the foreman for work on the next, and if there be nothing ready the repairman is given a card marked "waiting time," this card being used in the same manner as the others. This feature of the system forces the foreman to plan his work ahead so there will be as few "waiting time" cards as possible.

This garage card recorder system has proved its worth on numerous occasions by showing that a car was in the garage, when its owner has been accused of having been the cause of some serious accident, or other offense. Its chief value naturally lies in the check it keeps on the owner's employee so that the latter cannot use the car at night.

### STUDEBAKER GASOLINE-DRIVEN AMBULANCE.

One of the first gasoline-driven ambulances to be used in this part of the country has just been delivered to the Kings County Hospital, Brooklyn, by the New York branch of the Studebaker Company. It is built on the standard Studebaker 30-35-horsepower chassis, with a 136-inch wheelbase, and represents a new type, of which several are now under construction for hospital use. Four collapsible berths are provided, so arranged that they can be folded up out of the way when not in use. Access to the interior is gained both from the rear and from the side, just behind the driver's seat. The smooth and quiet running of the gasoline motor and the great ease with which it can be controlled, as well as its far greater speed and unlimited radius of action make the gasoline ambulance far superior to the electric for emergency service, and the wonder is that its unlimited possibilities in this direction have not been realized much sooner than has been the case, for next to getting to fires promptly there is nothing in which speed is so often a matter of life and death as the numerous calls for an ambulance which are a daily part of life in every large center of population. The panting and galloping horse with the clanging wagon behind him is a familiar sight in every city, and the fuss he makes in covering the ground gives an impression of great speed, but the manner in which runabouts and touring cars on pleasure bent swiftly glide by and still keep within the legal speed limit shows more plainly than words that the ambulance horse's speed is as much vertical as it is horizontal, which accounts for the poor progress made.



New Studebaker Ambulance Put Into Service by the Kings County Hospital.





A Charming Quintette of Stevens-Duryea Girls.

The ladies of the office force of the Stevens-Duryea Company, of Chicopee Falls, Mass., occasionally take a little time from their office duties and enjoy the pleasures of a short trip in a Light Six Model U Stevens-Duryea Touring Car. The illustration shows them returning from one of the runs.

### EFFICIENCY OF THE "BLUE BOOKS."

Every year these "Blue Books" demonstrate more and more ingenuity in construction and draughtsmanship. Especially is this the case with the general maps of the New England issue, placed rightly, at the very beginning of the volume.

Every city which is the center of a section is identified by a number within a circle, which corresponds to the page on which the information relating to all the routes radiating from that city is to be found, while intermediate and terminal points are taken further care of in the general index; and a new and original feature has been added in special diagrams, showing the entrances to and exits from all the principal places.

It might be thought that this multiplicity of directions and minute details would tend toward confusion, but it does not. Its interpretation indeed may, when en route, be left to any member of the party, down to the youngest capable of reading, and, furthermore, it is a bound book, and not a book just glued together at the back. It will, with moderate protection from the rain, stand the wear and tear of a long season.

It will no doubt interest users of the present "Blue Books" to know that the publishers have in preparation an additional volume (No. 4), covering the main-traveled automobile routes in the Middle West. Broadly speaking, the new work will deal with the important territory between Cleveland, Toledo, Chicago and Milwaukee on the north and the Ohio River on the south, with various extension and connecting routes.



A. Y. Bartholomew in His Glide, and His Bride-Elect.

Mr. Bartholomew, who is vice-president of the Bartholomew Company, of Peoria, Ill., is at the wheel, and sitting beside him is his fiancée, Miss Lucy Hubinger, of Peoria. The happy event is to occur in the middle of the summer. The bridegroom-elect is the son of J. B. Bartholomew, president of the company.

## THE AUTOMOBILE CALENDAR.

### AMERICAN.

#### Shows and Meetings.

- June 25-27.....—Detroit, Third Annual Summer Meeting of Society of Automobile Engineers.
- Dec. 31-Jan. 7..—New York City, Grand Central Palace, Ninth Annual Automobile Show, conducted by the American Motor Car Manufacturers' Association, with Exhibits by the Importers' Automobile Salon, Inc., Alfred Reeves, general manager, 29 West 42d St.
- January, 1909..—New York City, Madison Square Garden, Ninth Annual National Show of the Association of Licensed Automobile Manufacturers. (Exact date to be announced.)
- February, 1909 —Chicago, Coliseum and First Regiment Armory, Eighth Annual National Exhibition, National Association of Automobile Manufacturers. (Exact date to be announced.)

#### Races, Hill-Climbs, Etc.

- June 5.....—Jamaica, L. I., Straightaway Time Trials, Long Island Subway Celebration Committee, Assisted by Long Island Automobile Club.
- June 6.....—Worcester, Mass., Dead Horse Hill Climb, Worcester Automobile Club.
- June 9.....—New York City, Orphans' Day, Committee of Fifty of the Local Trade.
- June 10.....—Baltimore, Orphans' Day Automobile Outing, Automobile Club of Maryland.
- June 13.....—Hartford, Conn., Orphans' Day, Automobile Club of Hartford.
- June 17.....—Buffalo, N. Y., Orphans' Day, Automobile Club of Buffalo.
- June 24-27.....—New York and Philadelphia, Double-Head Endurance Run to Delaware Water Gap, under the auspices of the "Public Ledger" of Philadelphia.
- June 24-27.....—Chicago, 1,200-mile Reliability Run, Chicago Motor Club.
- June 27.....—Norristown, Pa., Skippack Hill Climb, Norristown Automobile Club.
- July 4.....—Lowell, Mass., 250-mile Road Race, Lowell Automobile Club.
- July 4.....—Wildwood-by-the-Sea, N. J., Annual Speed Tournament, Motor Club of Wildwood.
- July 7-8.....—Buffalo, N. Y., National Convention of the American Automobile Association.
- July 9.....—Buffalo, N. Y., Start of the Fifth Annual A. A. A. Reliability Touring Contest.
- Sept. 5-9.....—San Francisco-Los Angeles Reliability Run, Automobile Dealers' Association of San Francisco.
- Sept. 14.....—Chicago, Annual Economy Run, Chicago Motor Club.
- October.....—Vanderbilt Cup Race, Long Island Course, auspices of Vanderbilt Cup Commission.

### FOREIGN.

#### Shows.

- October 11-18...—Paris, International Congress and Public Exhibition on Roads and Road Making for Modern Locomotion, French Ministry of Public Works.
- December.....—Paris, Eleventh Annual Salon de l'Automobile, Grand Palais, Automobile Club of France.

#### Race Meets, Hill-Climbs, Etc.

- June 1-18.....—Reliability Trials for Pleasure Cars, Automobile Club of Great Britain.
- June 14.....—Mount Cenlis Hill Climb, for Voiturettes.
- June 9-17.....—Touring Competition for the Prince Henry of Prussia Prize, Germany, Imperial A. C.
- June 15-19.....—Scotland, Annual Scottish Reliability Trials.
- July 6.....—Voiturette Grand Prix, Dieppe Circuit (Automobile Club of France.)
- July 7.....—Grand Prix of Automobile Club of France, Dieppe Circuit.
- July 13-17.....—Ostend, Belgium, International Race Week, Automobile Club of Ostend.
- Aug. 12.....—Ardennes Circuit Races and Coupe de Liedekerke, Automobile Club of Belgium.
- Aug.....—France, Coupe de la Presse, Automobile Club of France. (Exact date to be announced.)
- Aug. 29-30.....—France, Mont Ventoux Hill Climb, Vauclusien Automobile Club.
- Sept. 1-8.....—French Voiturette Contest, Auspices "L'Auto."
- Sept. 6.....—Bologna, Italy, Florio Cup Race, Automobile Club of Bologna.
- Oct. 11.....—Berlin, Germany, Gordon Bennett Balloon Race, Aeronautical Club of Berlin.

## PUBLIC UTILITY OF HIGH-ROAD TRAINS ON FRENCH HIGHWAYS

THE following information concerning the running of passenger and freight trains on the highways of France is furnished by Consul-General Robert P. Skinner, of Marseilles:

There recently passed this consulate a "Train Renard," composed of a locomotive, two passenger cars, and one baggage car, which had just arrived from Paris under its own power and over the ordinary roads, thus supplying to the public a demonstration of its own efficiency. The trains mentioned are composed of elements, each receiving the energy of a vehicle called the locomotor, which being placed at the head of the train distributes the necessary power to the following elements by means of a transmission shaft extending from one end of the train to the other, thus enabling each car to utilize its own adhesion to the road surface as a means of advancement.

The locomotor—that is to say, the creator of the energy—is therefore lighter than any of the cars. Trains of this type completely loaded are able to maintain a speed of 21 kilometers (13.05 miles) per hour in case of passenger trains on levels and of from 15 to 16 kilometers (9.32 to 9.94 miles) per hour in the case of freight trains. It is said that freight trains of this type are able to maintain an average of from 10 to 12 kilometers (6.21 to 7.45 miles), fully loaded, in any kind of country.

It would be useless to enter into further details regarding

these high-road trains, as far as the United States is concerned, inasmuch as we are without a road system sufficiently advanced to make their application possible. On the other hand, the adoption of passenger and freight trains over railless roads in France has become not only a possibility but a fact. Already hundreds of inaccessible hamlets hitherto served by slow-going diligences, are kept in constant contact with the outside world by means of large auto-omnibuses, moving at an average rate of 15 miles an hour, transporting both passengers and express parcels; and now, following this development, comes the explosive engine motor, drawing full trains of cars, which it is claimed can be operated on level or mountainous roads at an exceedingly moderate expense. In other words, if all that is claimed for these trains is realized, it will be possible to give 25,000 communes in France, which do not at present enjoy railroad facilities, approximately the same advantages with respect to transportation as the more populous and highly favored centers.

This illustrates how much the creation of a better highway system would benefit the rural populations of the United States, who are at a great disadvantage in regard to transportation as compared with foreign communities, and deprived of the various kinds of satisfaction resulting from the existence of modern highways.

## THE WORLD'S AUTOMOBILE TRADING ACCOUNT WITH FRANCE

PARIS, May 25.—Though the total exports for January, February, March, and April of the present year are lower than the corresponding periods of 1907 and 1906, there has been a sufficient increase during the past month to give ground to the belief that 1908, as a whole, will not be such a slack year as was expected some time ago. With the total automobile exports for the first four months of 1908 standing at \$8,376,400, the deficit on the same period of 1906 is only \$863,200. Compared with 1907 the deficit is \$2,011,200, the figures for the first four months of 1906-7-8 being: \$9,239,600, \$10,387,600 and \$8,376,400. These figures include automobile exports only, motorcycles and their parts being classified separately.

The United States, Russia, Algeria, Turkey and Spain are the only countries having increased their trading account with France during the first four months of the current year. England, the best customer, has taken automobiles to the value of \$118,000 during the month of April alone, bringing the total up to \$3,782,000 for the first four months of the year, this amount being a trifle higher than that of 1906. Nine other countries have cut down their automobile trading accounts with France.

During these four initial months the United States has taken in French cars to the value of \$846,800, an amount which is higher than both 1906 and 1907. The trading account per nation, as shown by the Government returns is as follows:

French Automobile Exports for First Four Months of 1906-7-8.

Country	1906	1907	1908
Great Britain.....	\$3,722,000	\$4,587,600	\$3,782,000
United States.....	819,400	789,000	846,800
Germany.....	1,335,800	1,001,200	723,200
Belgium.....	1,066,000	1,055,600	624,200
Algeria.....	245,000	257,400	357,600
Argentine Republic....	533,200	509,200	299,600
Spain.....	115,800	150,000	242,200
Russia.....	78,600	65,600	226,000
Brazil.....	52,400	342,400	163,600
Italy.....	533,600	339,400	147,400
Switzerland.....	174,000	299,600	107,800
Turkey.....	22,600	10,800	41,600
Austria.....	35,600	45,200	19,800

Of the four nations sending automobiles into France, England alone has increased her trade during the four months under review, the amount having risen from \$18,000 in 1907 to \$21,200 during the first four months of 1908. America's trade dropped from \$7,800 to \$3,800; Germany's business shows a drop from \$180,000 to \$149,400.

### FRANCE PROMINENT IN MOSCOW SHOW.

Moscow, May 20.—A religious ceremony, followed by an elegant luncheon, marked the opening of the Moscow automobile show, presided over by the Military Governor of the city and assisted by the consuls of America, England, France, Germany, and other European countries. France believes there is good business to be done with Russia, now that the effects of the war are practically over, and has made every effort to be first in the new field. She has so well succeeded that French cars occupy almost all the stands, the only exception being Fiat, from Italy, Germain and Pipe from Belgium, Mercedes from Germany, and Humber from England. Touring cars, as well as commercial vehicles, are shown and are attracting attention. American firms, though having previously done business with Russia, are not represented at the exhibition.

### INCREASE OF TAXICABS IN LONDON.

Consul-General Robert J. Wynne reports that taxicabs have become such popular street vehicles in London that the demand for them is much greater than the supply. He adds:

"The taxicabs are used by all classes of people, day and night, at the uniform rate of 16 cents a mile, and they represent a most attractive appearance in chocolate, blue, yellow, red and green hues, with chauffeurs in the brightest and smartest liveries. Although scarcely a year has passed since these swift-moving electric and petrol carriages appeared, the capital already invested in London taxicabs is \$10,000,000. There are 758 taxicabs on the streets, 2,600 taxicabs on order, 1,700 licensed drivers, an average of 55 certificates granted each week. There are eight London taxicab companies, their average day's takings of a taxicab being \$11.20.

# THE AUTOMOBILE

Vol. XVIII

Thursday, June 4, 1908

No. 23

## THE CLASS JOURNAL COMPANY

Flatiron Building, Madison Square  
New York City

H. M. SWETLAND, President

### EDITORIAL DEPARTMENT

A. G. BATCHELDER, Managing Editor

R. F. KELSEY, Associate Editor      C. B. HAYWARD, Engineering Editor

W. F. BRADLEY, Foreign Representative

### BUSINESS DEPARTMENT

A. B. SWETLAND, Business Manager

LOUIS R. SMITH      FRANK B. BARNETT

W. I. RALPH, 1035 Old South Building, Boston, Mass.

C. H. GURNETT, H. E. WESTERDALE, 1200 Michigan Ave., Chicago, Ill.

Cable Address - - - - - Autoland, New York  
Long Distance Telephone - - - - - 300 Gramercy, New York

### SUBSCRIPTION RATES:

United States and Mexico - - - - - One Year, \$3.00  
Other Countries in Postal Union, including Canada - - - - - One Year, 5.00  
To Subscribers—Do not send money by ordinary mail. Remit by Draft,  
Post-Office or Express Money Order, or Register your letter.

### FOREIGN SUBSCRIPTION AGENTS:

ENGLAND:—W. H. Smith & Sons, Ltd., 186 Strand, London, W. C., and all their  
railroad bookstalls and agencies throughout Great Britain; also in Paris at  
248 Rue de Rivoli.

FRANCE:—L. Baudry de Saunier, offices of "Omnia," 20 Rue Duret, Avenue de  
la Grande Armee, Paris.

GERMANY:—A. Seydel Mohrenstrasse 9, Berlin.

Entered at New York, N. Y., as second-class matter.

The Automobile is a consolidation of The Automobile (monthly) and the Motor  
Review (weekly), May, 1902, Dealer and Repairman (monthly), October, 1903,  
and the Automobile Magazine (monthly), July, 1907.

Copies printed in 1905	- - - - -	730,000
" " in 1906	- - - - -	791,000
" " in 1907	- - - - -	888,000

## THEN, LET'S HAVE AN AMERICAN RACE.

When one applies the uncompromising rules of logic he is unable to supply reasons why the automobile manufacturers of the United States, who consider racing a commensurate advertisement for the money expended, have not the same right as the European makers to decide as to what rules shall govern them in so doing.

When the American maker goes abroad to race he always has accepted as a part of the contract the existing foreign regulations, even when it has cost him considerable expense and effort to comply therewith. Until this year of our Lord 1908 the racing visitors to this side of the ocean have been subjected to no greater inconvenience than the voyage itself.

But this year for the classic Vanderbilt Cup race the committee having the event in charge, and containing representatives of the American manufacturers, have had the temerity to establish rules which do not this time coincide exactly with the foreign regulations which annually receive an overhauling. It is even known that the American committee took into consideration the fact that certain prominent American makers had gone to no small outlay in preparing for a 1907 race, which did not take place because a properly guarded course could not be secured and Mr. Vanderbilt and his associates were averse to repeating the experiences of 1906, marred by one fatality and scores of narrow escapes of various kinds.

It was then that the Long Island Motor Parkway was

born, and its dedication will be the 1908 Vanderbilt race, the rules for which say that every part of a car must be manufactured in the country from which it is entered. Furthermore, a maker is told that his car must weigh at least so much—thus preventing skeleton construction—and is also informed that it must not weigh more than a certain figure—thus barring monster road locomotives. Surely these ideas are not so very reprehensible, even from an engineering standpoint.

And, now, just a few words about the international rules, so called—though it would not seem that they are entirely international when the country making more automobiles than any two European countries combined had nothing to say in their adoption. In the first place, nothing is said about the entire car being made in the country from which it is entered, which would appear to be the first requisite of an industrial competition—and that is exactly what automobile racing has become. Granted that it is only just that the race governing body of a country should take into reckoning the wishes of the home makers, certainly this is thoroughly done in France, where its club turns racing over to a committee which is dominated by the makers, and one of them is even the chairman. Please keep this in mind when passing upon the merits of the French objections to the 1908 Vanderbilt conditions; also connect with the British kick the fact that that country has never had a car in the American race, and at the same time it might be well to recollect that the leading British firm—Napier, to be specific—is not taking part in the French Grand Prix because it does not like the rules.

These rules say that a car must weigh at least so much, and the figures are identical with the Vanderbilt minimum weight. But instead of establishing a maximum weight, the rules limit the amount of piston displacement; last year the fuel was the limit used to prevent the building of abnormal cars. Despite the fact that the piston displacement is limited, four-fifths of the cars in the Grand Prix exceeded 100 horsepower, and it is safe to predict that measured by the same dynamometer the top horsepower of the Vanderbilt list will not exceed the most powerful Grand Prix car. In the opinion of the experts, 100 horsepower is sufficient to travel at the greatest possible speed on any highway that now exists. But the Europeans, mayhap fearful of defeat, say that they will not compete in the Vanderbilt race unless the rules coincide; nor will they relieve their fears by substituting another engine with greater piston area, though they have months in which to do so. In other words, you must play always according to their rules, or it will be a case of getting into another yard—if one is supplied. Therein comes the other part of the story.

At Chicago, in March, 1902, the American Automobile Association was formed. The following year, in the club book of the Automobile Club of America, there appeared the following:

The American Automobile Association, embracing in its membership the principal automobile clubs of the United States, was formed in March, 1902, one of its functions being to regulate and control automobile racing in the United States.

All authorized race meets in the United States are now held upon sanction from and under the racing rules of that association, of which the Automobile Club of America is a member.

In view of the fact that the A. C. A. "corresponded" with the foreign clubs previous to the organization of the A. A. A., that arrangement was not disturbed, and pos-

sibly might have continued indefinitely if recent events had not transpired. It is pertinent to know, however, that no authority has ever been invested in the A. C. A. by the A. A. A., whereby the club could obligate the national body in international affairs. The club acted as "correspondent"; there its function ended.

And it would appear that occasionally its manner of transmitting this correspondence was open to the charge of neglect, for at such an important affair as the Ostend meeting, in July last, no delegate from the club attended, and consequently did not participate in the discussion of the much-referred-to racing rules. It is a fact of record that the secretary of the A. C. A. did send to the secretary of the A. A. A., in September last, a copy of the rules which had been adopted at Ostend, but unaccompanied by any comment whatever. There was no reference to any assumption on the part of the A. C. A. that it considered the A. A. A. holden to the acceptance of the rules, and certainly there could not have been any assumption of authority on the part of the club to bind the American race-controlling body, for the particular reason that the club did not even have a delegate present. At a subsequent session of the international gathering in Paris the club delegate did attend, and now states that he accepted the rules in behalf of the club, though the club never sent any notification to this same effect to the A. A. A., nor did the examination of its records betray any evidence that any such authority had been assumed.

But the impression has existed in Europe, apparently, owing to the similarity of names, that the club was the "whole thing," and that it even conducted the Vanderbilt race. Thus the confusion of the situation by the foreign clubs, which, for the present purposes of the A. C. A., is contorted into a demand that the club supply the foreign makers with a race under the so-called international rules. True it is that these same foreign clubs have practically

ignored the Vanderbilt race in recent years, the French club after its killing of the Gordon-Bennett declining to assist in the selection of a team from that country. And one can accept the statement that what the French club says is as good as the verdict that will be agreed upon ultimately, even though slightly modified.

Then we reach that part of the story where it is necessary to ask as to where the American manufacturer gets off in the premises. It would seem a plain matter of common sense and justice that he compete in the American race, in the drawing up of the rules for which he had a voice. As to why he should now build other cars for the sole purpose of assisting the club in giving the foreigners a race, according to their rules of this year—which may change again next year—is something that finds him in a rather diffident mood, for it costs the American maker more to build a racing car than it does the European, labor being cheaper on the other side.

When the recently-elected president of the A. C. A., who is a busy man and a business man, brand new in automobiling, gains a thorough knowledge of the situation, it is not unreasonable to surmise that there will be some change of the mushroom policy of the expensively-run and heavily-bonded clubhouse in West Fifty-fourth street, the support of which does not devolve upon the industry, nor upon automobilists generally, for each city should supply the revenue for its local club. The New York City club should be content to be a part of the whole, and not try to be the whole thing, for this is a very big country, and the people in it—automobilists as well as others—have not yet placed the seat of government in New York City, even if it is the metropolis.

The Vanderbilt Cup race deserves the support of the American makers, which it will get. As to any other race—well, the future will tell as to what degree of representative American support it will receive.

## N. A. A. M. AFFIRMS POLICY OF SUPPORTING A. A. A.

AT the meeting of the National Association of Automobile Manufacturers, held at the association's headquarters, 7 East Forty-second street, New York City, Wednesday afternoon, June 3, President Henderson called attention to the existing situation as regards the position of the American Automobile Association in national affairs in this country, but stated that as the N. A. A. M. had placed itself on record some time previous as being in due accord with the aims and policies of the three A.'s, there was no necessity for further formal action.

President Henderson says: "We shall uphold the American Automobile Association and the policies which it has outlined as

represented through its Central Conference Committee, which is representative of the entire American automobile industry."

An election was held to fill existing vacancies, W. C. Leland taking office as the representative of the Cadillac Motor Car Company, vice W. E. Metzger, resigned; Marcus I. Brock was elected to represent the Autocar Company, and Edwin R. Thomas was elected to represent the E. R. Thomas Motor Company, Buffalo. The following were present: Thomas J. Henderson, A. L. Pope, W. E. Metzger, Charles C. Clifton, H. B. Joy as proxy for S. D. Waldron, H. L. Smith, Benjamin Briscoe and Windsor T. White.

### AN UNBIASED VIEW OF THE SITUATION.

The New York Times is one of the several New York dailies which prints impartially the news of the Automobile racing controversy. Here is what it commented on Monday last:

What policy may be pursued with respect to uniform regulations for international races in America remains for the American manufacturers who compete to decide. It is true, nevertheless, that the Ostend conference is dominated by the Automobile Club of France, and that the Automobile Club of France is dominated by the French manufacturers. In fact, the head of the club Contest Committee is the managing director of the Panhard Company. If the rules dictated by the Automobile Club of France are proper rules, they will undoubtedly in the end prevail, but the American manufacturers have expressed by their action their resentment of French dictation.

### RHODE ISLAND PASSES HORSEPOWER TAX LAW.

PROVIDENCE, R. I., June 1.—After having undergone numerous slight amendments for which members of the Senate and House stood out for, a compromise was finally reached and the bill passed both houses unanimously. The chief departure from precedent in this and other States is the adoption of a horsepower tax, which is \$5 per annum up to and including cars of 20 horsepower; \$10 for 20 to 30 horsepower; \$15 for 30 to 40 horsepower and \$25 for cars of over 40 horsepower. Dealers' licenses will cost \$50, and drivers' licenses will cost \$1 in the case of a car and 50 cents for motorcycle riders. The amendment prohibiting tire chains was killed and they may be used on slippery roads under the law as it now stands.



## CEDRINO MEETS TRAGIC DEATH.

BALTIMORE, May 29.—Emanuel Cadrino, while practicing on the Pimlico course for to-morrow's meet, met instant death. He was working out the Fiat *Cyclone*, a well-known racing car, when the accident occurred. He had made three rounds of the mile circuit. The first he covered in 56, the second in 53 2-5, and the third in 51 seconds. Again he started with 50 seconds, and the gasoline track record in view. As the flyer turned into the backstretch, the right front tire gave way, and the wheel collapsed. The car turned a complete somersault. Cadrino was picked up dead.



Emanuel Cadrino.

Emanuel Cadrino came to this country four years ago direct from the factory of the Fiat Company in Milan, to enter the employ of Hollander & Tangeman, the American agents. Cadrino had had charge of the mechanical force of the Fiat

team for the Gordon-Bennett races in France and Germany.

Soon after arriving here he continued his racing career, which had been begun by participation in the Mont Cenis hill-climb and other Italian contests, making his first appearance at Elkwood Park in 1905. On this occasion he established a new 50-mile track record. Cadrino drove one of the Fiat cars in the Vanderbilt race of 1905, but did not take part in the race of the following year, owing to a trio having been sent from Italy to man the cars. He was second in the Briarcliff race this spring.

With the rising popularity of 24-hour track racing, Cadrino once more took up competition and evolved the winner of the last race of this character held at Morris Park at the close of last season. His most remarkable feat, however, was his driving the Fiat *Cyclone* on Ormond beach 300 miles at the rate of 77 miles an hour. He was confident at the Baltimore meet he would beat Christie's mile record of 51 2-5 seconds for gasoline cars. In fact, he had just scored 51 seconds in practice before the fatal round wherein he met his death.

His widow will take back to Italy with her on Saturday, when she sails in company with the body of her late husband, close to \$7,000, made up of insurance, bank savings, gifts by friends, of the Fiat Company, and smaller tributes, including one from the Flat Tire Club.

The funeral services took place to-day at the Italian Catholic Church, on Thirty-sixth street, between Ninth and Tenth avenues, and was largely attended by the trade and racing fraternity, with whom the deceased was deservedly popular.

## FLORIO CUP RACE ON SEPTEMBER 6.

PARIS, May 20.—Italy will hold its most important high speed test under the international rules decided upon at the Ostend conference, the date of the meeting for the Florio Cup being Sunday, September 6, and the place the circuit of Bologne. Originally it had been intended to close the entries on May 31, but the decision has just been taken to postpone this until July 31. It is practically certain, however, that all the important French firms will take part in the Italian race. Owing to the importance of the event to French manufacturers. Victor Breyer, representative of the American Automobile Association in Paris, has been appointed special commissioner in France for the Florio Cup race.

## GERMAN CLUBS ASK CONCESSIONS FOR TOURIS

BERLIN, May 15.—At the last meeting of the delegates of the Imperial Automobile Club and the affiliated clubs, the resolution was passed to petition the government to relieve foreign motor cars touring in Germany from all taxes for a period of sixty days. It will be interesting to see whether or not the clubs will have any success.

## PROGRESS IN JERSEY TEST CASE.

TRENTON, N. J., May 29.—As was generally anticipated, the hearing in the case of R. H. Johnston, who is testing the constitutionality of the Jersey law on behalf of the touring bureau of the White Company, resulted in his conviction by Police Justice Harris, and a fine of \$100 was imposed. The White Company was represented by X. P. Huddy and Peter Backes, while Assistant Attorney-General Nelson Gaskill and Theodore Backes appeared for the State. Before judgment was rendered, Mr. Huddy made a motion to dismiss the complaint, basing it upon the following grounds:

First—That the required tax of \$10 per year which the New Jersey law demands of a non-resident owner of an automobile is a revenue tax and not a license fee imposed under the police power; that this revenue tax imposes an unconstitutional restriction upon the privilege of a non-resident citizen to enter the State of New Jersey, thereby infringing his liberty as guaranteed by the Federal constitution.

Second—That the New Jersey tax of \$10, for the non-payment of which this defendant was arrested, constitutes an unconstitutional tax on interstate commerce, violating the Federal constitution which places interstate commerce within the exclusive jurisdiction of the United States government.

Third—That this court has no power to impose a fine as directed by the New Jersey statute, since the New Jersey tax in question is a revenue tax, this proceeding being non-criminal in its nature, and this court here to-day, if it imposes a penalty under the revenue tax, will be exercising the power of taxation, which is exclusively delegated to the legislative department of the government to the exclusion of the judicial.

Fourth—That this court has no power to impose a fine because the penalty, as prescribed in the New Jersey law, is discretionary with this court up to the sum of \$100, and that in order for the law to be valid, the exact and precise fine must be determined by the law imposing the tax, and the power of the legislature to impose a tax cannot be delegated to this court.

Justice Harris overruled this motion, whereupon an exception was taken. The defendant was then convicted and sentenced to pay a fine of \$100. Mr. Johnston's counsel immediately gave notice of an appeal to the Court of Common Pleas, where the constitutional questions involved will be determined.

## MORA "SIX" FIRST VANDERBILT ENTRY.

Although there have been rumors and statements of more weight than usually attach to the latter, that several cars had already been actually entered for the Vanderbilt Cup race this fall, Chairman Jefferson De Mont Thompson's letter of a few days ago to W. W. Burke of the New York branch of the Mora Company, Newark, N. Y., places a very different light on the matter. To S. H. Mora belongs the honor of having actually made the first entry for the American classic, and his company will be represented by a six-cylinder car which is now under construction at the new Mora factory.

## MAY HAVE TWO CARS IN THE VANDERBILT.

It is said that Harry Levey, a New York sportsman, has pretty well made up his mind to make a double entry for the Vanderbilt Cup race through the nomination of his Hotchkiss and Woolsley racers. The Hotchkiss to be entered is the 130-horsepower car which Elliot T. Shephard drove in the last international race on Long Island.

Mr. Levey is an enthusiast with money to back his new hobby. His first entrance into the racing game was made at Ormond last winter with this same Hotchkiss.

## TO START BUILDING PARKWAY SATURDAY.

Much enthusiasm has been evinced by the fraternities of sport and trade in the formal beginning of the Long Island Motor Parkway work at Central Park, Long Island, on Saturday, when at half past three in the afternoon, W. K. Vanderbilt, Jr., will cast the first spadeful of dirt. A big, spontaneous outpouring of automobilists is expected at the ceremony, which will take place on the Barnes tract, Jerusalem road.

## VANDERBILT CUP RACE TO BE HELD OCT. 24

**T**HE Vanderbilt Cup Commission has set Saturday, October 24, as the date for the next international race in this country. The course will be announced at least thirty days before the race. The distance will not be less than 250 nor more than 300 miles. Entries will close on September 1. Deferred entries will be accepted up to October 1 at a double fee of \$2,000.

The national automobile clubs of France, Germany, Belgium and Great Britain have shown their appreciation of the Automobile Club of America's proposal to run a road race under European rules by casting their American racing lot with the New York Club, and giving it formal recognition as their representative in this country. At a meeting of the club's board of governors on Tuesday the following telegrams were presented:

Paris, June 2, 1908.

The Automobile Club of America, New York:

The Commission Sportive has decided to-day to recognize as official the Grand Prize race, organized by the Automobile Club of America, which is to be run under rules adopted at Ostend, and to disqualify all French cars taking part in the Vanderbilt Cup race; and, furthermore, the Automobile Club of France will continue to recognize no one but the Automobile Club of America as its official representative.

[Signed] BARON DE ZUYLON.

London, May 30, 1908.

The Automobile Club of America, New York:

Your position as our representative will be upheld. Congratulate you on organizing Grand Prize race. Will endeavor to induce entries from this side.

[Signed] J. W. ORDE, Secretary.

Brussels, June 2, 1908.

The Automobile Club of America, New York:

We will maintain and respect the agreements and rules adopted at the congress of Ostend in 1907.

[Signed] AUTOMOBILE CLUB DE BELGIQUE.

Berlin, May 29, 1908.

The Automobile Club of America, New York:

Imperial German Club has joined by letter, dated May 25, the protests of the French and English clubs, and has enjoined German automobile factories not to participate in Vanderbilt Cup race. We endorse the projected Grand Prize race of the Automobile Club of America.

KAISERLICHER (IMPERIAL) AUTOMOBILE CLUB.

Another cable was also presented, which is more interesting and somewhat sensational. It was from W. S. Hogan, one of the club's foreign representatives, and was as follows:

Paris, May 31, 1908.

The Automobile Club of America, New York:

French club much interested in your Grand Prize race. Holding extraordinary meeting Tuesday. Will then cable fully.

French club has also received cable from American Automobile Association offering to amend Vanderbilt conditions, if proposals sent direct to them.

[Signed] HOGAN.

"No cable was ever sent to the French or any other European club that could be contorted into an offer to amend the Vander-

bilt Cup rules," said Chairman Thompson, of the Vanderbilt Cup Commission. "The only cable transmitted was that directed by the Racing Board at its last meeting to be sent notifying the Automobile Club of France and the Royal Automobile Club of Great Britain that the A. C. A. was merely a local club, and that any communications sent direct to the American Automobile Association would receive courteous attention." The contents of this cable embraced solely a copy of the following resolution, which has already been widely published:

**RESOLVED:** That Jefferson deMont Thompson, the chairman of this Board and of the Vanderbilt Cup Commission, be instructed to notify the corresponding boards or committees of the representative automobile associations and clubs of foreign countries that the Automobile Club of America is a local club situated in the city of New York without national functions or jurisdiction, and

That all communications concerning national or international affairs must be addressed to the American Automobile Association at its headquarters, No. 437 Fifth avenue, New York City, or to the chairmen of its respective boards; and

That so far as the rules of the Vanderbilt Cup race for 1908 are concerned, on receiving a communication direct from any foreign association or club concerning such rules, this board will give such communication prompt and courteous consideration.

A press dispatch from Savannah, under date of Tuesday, states that at a meeting of the local club held that day, the terms of a contract with the New York club for a race in November were accepted, that the action was telegraphed to the New York club's contest committee chairman, and that his acknowledgment had been received. The dispatch further stated that the Savannah Automobile Club would resign its membership in the A. A. A.

President Hotchkiss, of the A. A. A., makes the following comment on the action of the French club:

If the French manufacturers who compose the majority of the Committee Sportive of the French club, and one of whom is also the chairman, decline to compete under American rules, then the loss will be theirs, not ours. Although this feature concerns us but slightly, we are already assured of a sufficient number of foreign entries to give an international flavor, and are able to promise the automobile public that the 1908 Vanderbilt Cup race will be the banner event in its classic history. This race will be held October 24, over a stretch of the new Long Island Motor Parkway and necessary adjoining roads to complete the most perfect course ever supplied for such a race. William K. Vanderbilt, Jr., president of the Parkway, on Saturday next will turn the first spadeful of earth, and 1,500 laborers will be at work two days later.

It is perhaps pertinent to inquire why it is that a local American club in New York City is so anxious to assist a few disgruntled French manufacturers to compete with each other in a race in the United States. As for the American Automobile Association, it believes in America for Americans, and in the international supremacy of the American automobile through American contests conducted under American rules. If the French club does not want to compete under such rules, the loss is, I regret, theirs, not ours.

### WILL GIVE FOREIGNERS A RACE TO SUIT.

The directors of the Automobile Club of America, of New York City, met last week and adopted the following resolutions:

"Resolved, That the Automobile Club of America hold in the fall of 1908 a road race under the rules of the International Association of Recognized Automobile Clubs as adopted at Ostend, July 14, 1907, and that the contest committee of the club be empowered to organize and carry out such a race.

"Resolved, That the Automobile Club of America give a gold cup, to be known as 'The Grand Prize of the Automobile Club of America,' to be competed for annually in a road race to be conducted under the auspices of the Automobile Club of America under the rules adopted each year by the International Association of Recognized Automobile Clubs.

Resolved, That the Automobile Club of America organize and conduct each year the following events:

"1. The international road race for the grand prize of the Automobile Club of America under the rules of the International Association of Recognized Automobile Clubs as may be adopted.

"2. An international stock car race for the Briarcliff trophy.

"3. A long distance touring car contest.

"4. A hill climbing contest.

"Resolved, That the secretary of the club be instructed to communicate these resolutions to all of the clubs and organizations with whom it is affiliated."

### LOOKING FOR VANDERBILT COURSE LOOPS.

Jefferson deMont Thompson, chairman of the A. A. A. Racing Board, and A. R. Pardington, manager of the Long Island Motor Parkway, Inc., in company with different members of the Board of Supervisors of Nassau county, have made several trips over the highways of that county during the past fortnight with the object of discovering what roads might be available for combination with the parkway stretch for use for the Vanderbilt Cup race next October. They intimate that their pilgrimages have not been in vain, but withhold for the present any hint of the route they have in view.

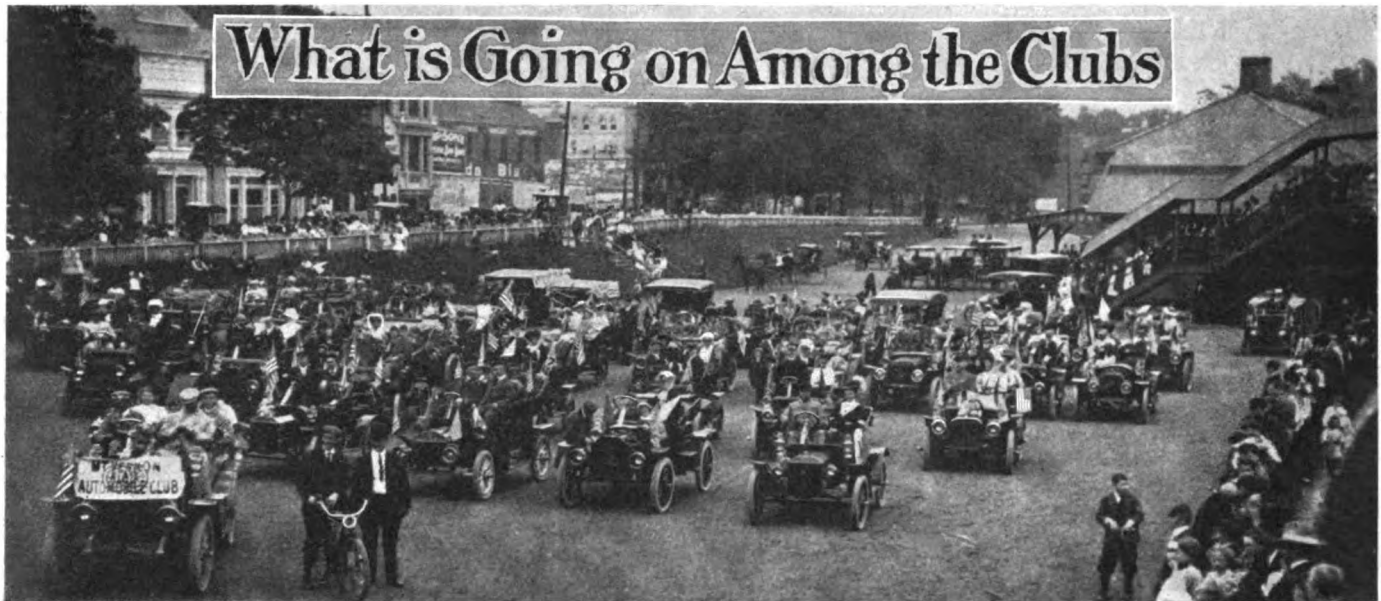

Mount Vernon (N. Y.) Automobile Club Ready for the Start of Its First Parade and Run.

#### MICHIGAN'S STATE BODY ELECTS OFFICERS.

GRAND RAPIDS, MICH., May 29.—The annual meeting of the Michigan State Automobile Association was held in this city today. Officers were elected, a good roads committee appointed, and a banquet was held in the evening at the Grand River Auto Club, at which President George was the guest of honor.

The new officers elected for the ensuing year are: President, Edwin S. George; first vice-president, A. A. Barber; second vice-president, J. R. Jackson; third vice-president, James G. Hatfield; secretary, Dr. D. Emmet Welsh; treasurer, Sidney D. Waldron. The following chairmen were named for committees: Good roads, Edwin S. George; tours and contests, Sidney D. Waldron; membership, J. R. Jackson; law, Dexter M. Ferry.

The association decided to make good roads the principal field of its endeavor this year, and the good roads committee will outline a plan which will be followed by the clubs belonging to the association. The association includes clubs at Detroit, Grand Rapids, Kalamazoo, Hart, Flint, Battle Creek and Cadillac.

#### DAVIS AND RIKER WILL GO TO BUFFALO.

BRIDGEPORT, CONN., June 2.—President F. T. Staples, of the Automobile Club of Bridgeport, has appointed the standing committees. They and their chairmen are: Membership, H. D. Gates; road signs, Arthur K. L. Watson; contests, Ralph M. Sperry; road repairs, H. E. French; tours and runs, H. D. Gates; legislative, Goodwin Stoddard; public safety, Jonathan Godfrey.

S. T. Davis, Jr., and A. L. Riker were appointed to represent the club at the Buffalo convention.

#### MOUNT VERNON CLUB HAS INITIAL PARADE.

MOUNT VERNON, N. Y., June 1.—The parade and run of the Automobile Club of Mount Vernon on Saturday afternoon, May 23, was a marked success. The interest shown in the initial appearance of the club in an event of this sort and the large number of cars in line argues well for a continuance of the enthusiasm which the organization manifests. All Mount Vernon turned out to do honor to the occasion.

#### GENEVA CLUB CHOOSES OFFICERS.

GENEVA, N. Y., June 2.—At the annual election of the Geneva Automobile Club, the following officers were chosen: President, F. W. Herendeem; vice-president, M. F. Blaine; secretary and treasurer, C. W. Fairfax. It was voted to send delegates to the Buffalo convention.

#### MONTREAL'S CLUB REELECTS M'DONALD.

MONTREAL, QUE., June 1.—A year of prosperity, with a considerable growth in membership and a healthy increase in funds, were reported at the annual meeting of the Automobile Club of Canada, held at the Windsor Hotel, the vice-president, U. H. Dandurand, presiding in the absence of President McDonald.

The work done to secure good roads, especially the competition for \$200 cash prizes offered for farmers who did the best work to improve the roads in front of their places, was the main feature of the report.

As a result of the work done by the club to suppress any breaches of the motor vehicle law, the report showed that there had been very few serious motor accidents during the past year, while not one of these could be attributed to reckless driving.

For the coming year the directors' program was to continue the good roads propaganda to the utmost limit. They intend to take the matter up with the Provincial Government, and will also spend as much money as they can to interest the proprietors on the Island of Montreal in improving their roadways. In addition to this, a series of route and caution signs will be tacked up on leading roads, showing the way to and from Montreal, and warning against dangerous pieces of road. The club also decided to take active steps to run down any motorists who break the laws by any kind of reckless driving.

The following officers were elected: President, Duncan McDonald; vice-president, U. H. Dandurand; directors, F. H. Anson, A. J. Dawes, Eugene Tarte, Wm. Caruthers, A. Berthiaume and Clarence Smith; secretary-treasurer, G. A. McNamee.

#### STRONG ARGUMENTS FOR JOINING CLUBS.

PITTSBURG, June 2.—In Paul C. Wolff, its secretary, the Automobile Club of Pittsburg has a live wire full of effective electricity. In the club's monthly publication he puts up arguments for automobilists joining the club, which may well be read and might well be used by other clubs in their canvass for members. The appeal says in part:

"The real reason for this club's existence is the work it is doing for the benefit of every user of a motor car in this vicinity, all of whom should certainly be interested in having the roads of the county properly maintained and marked by legible signs, in having a place where maps can be consulted and touring information secured, in the existence of a strong organization willing to protect them in case of unjust arrest, to endeavor to defeat any unfair legislation or local ordinances that may be introduced, and to work for the enactment of more liberal, up-to-date laws.

"This, the Automobile Club of Pittsburg is doing and in this it should have your support. As a member you also become a member of the State organization and of the American Automobile

Association, the National body. As a member of the former you aid in carrying on the work in Pennsylvania—of the latter in Federal legislation where the motorist must have recognition. You also benefit directly, having at your service valuable touring information.

"There are, of course, many men to whom this means nothing. The main objects for which club, State and national organizations are working, look to the advantage or benefit of all motorists alike, members or non-members, and there will always be individuals so small that knowing that this work will go on whether they contribute or not, and if successful that they will share the benefits, will keep their money in their pockets. The work can and will be done without their help, for there fortunately is a larger class, who, if they see efforts being put forth in directions which will benefit them, are perfectly willing to do their part toward supplying the sinews of war. These we wish to add to our membership list."

#### NEW YORK CLUB URGES SOME DON'TS.

NEW YORK, June 3.—The Automobile Club of America's committee of safety, in a circular to the press, repeats its recommendations of a year ago as to certain desirable reforms as follows: "We urge upon motorists the wisdom of not using acetylene lights on ferries or in closely built-up and well-lighted portions of cities and towns; also not to cut out the muffler, except in places where the noise of the exhaust cannot annoy or offend other users of the highway; also to avoid flooding the engine with oil, thus creating offensive smoke and odor."

#### BUFFALO CLUB TO ENTERTAIN ORPHANS.

BUFFALO, June 2.—The Automobile Club of Buffalo has designated Wednesday, June 17, as Orphans' Day, and as there are few organizations in the country in which the appeal for a worthy charity meets with a more generous response, it is a foregone conclusion that none of the youngsters will be forgotten. The total membership of the club is now 1,243.

#### HARTFORD'S CLUB CONTINUES TO GROW.

HARTFORD, CONN., June 1.—Now that the endurance run is off the slate, the Automobile Club of Hartford is making ready for Orphans' Day on June 13. Needless to say, the orphans throughout the city anticipate the day with longing.

The membership of the club continues to increase, and it is safe to assume that if things hold out the way they have been going for some weeks past, the membership will touch the 300 mark by autumn. There is much demand for a hill climb this fall, and one will be held, though it is doubtful if the same course will be selected, which, to the minds of many, is far too dangerous.

#### PENNSYLVANIA FEDERATION NOW HAS 24 CLUBS.

PITTSBURG, PA., June 2.—There are now twenty-four clubs in the Pennsylvania Motor Federation, the Monroe County Automobile Association, the Johnstown Automobile Association, and the Beaver Falls Automobile Club having made applications for membership. An active campaign is also being made for individual members to add weight and recruits to the Federation's influence and fight for more reasonable local and State legislation.

#### TO BANQUET BROOKLYN'S BENEFACTORS.

BROOKLYN, N. Y., June 3.—By way of formal recognition of their untiring and successful efforts in securing the passage of the Cypress Hills bill, the Long Island Automobile Club on Friday evening will give Senator Eugene M. Travis and Assemblyman William A. DeGroot a dinner at the Crescent Club's country clubhouse on the Shore Drive. The bill provides for a boulevard connecting Highland Park with Forest Park, and continuing out to the good roads of Long Island.

## FARMAN WANTS TO COMPETE WITH WRIGHT BROTHERS

PARIS, May 20.—There are hundreds of sportsmen in France who would readily put their name to a big check if by so doing they could fathom the Wright Brothers' mystery. France would like to believe that she leads the world in aeronautics, and at the bottom does believe it; but her peace of mind is troubled at too frequent intervals by reports from across the Atlantic of the doings of the two brothers from Dayton. Just when Delagrangé or Farman have made a magnificent performance in the presence of thousands of spectators and on a ground as accessible to Parisians as Central Park is to New Yorkers, just when she is ready to shriek with excitement at the prospect of wresting the secret of the feathered world, a blunt message comes from the West announcing a performance that makes the French flight look like the scurry of a scared hen. So often have they come that the Frenchman who at first scoffed and still calls them *vols de canards*, has begun to doubt, and has finally reached such a state that he would give his hard cash to know the truth.

Henry Farman, the Frenchman of British origin who has nothing of the bluffer in his make-up, has endeavored to solve the mystery by a public challenge, and now comes forth with \$5,000 stakes and the promise of a much larger amount if the Wright brothers will meet him in open competition in France for both time and distance flights. In his letter to the press the ex-automobile racing driver writes as follows:

"For some time I have seen in the newspapers that the Wright brothers have established numerous records, and that the next day everything connected with them has been denied. Personally I believe that the Wright brothers are very expert in aeronautics and capable of executing good flights. However, my small experience allows me to affirm that at any rate the published accounts of both recent and old flights are absolutely inexact. Among other examples I may mention the state-

ment in one account that three or four miles had been covered in 15 minutes, or something approaching this. Now it is absolutely impossible to fly as slowly as this. I am ready, however, to issue a challenge for speed and distance to be run in France.

"I can offer immediately stakes of \$5,000 and am certain of being able to get together a much larger sum if the Wright brothers accept the challenge. I propose this match with every confidence, for I have made more than 400 flights and covered a distance of about five kilometers, remaining in the air five minutes over a ground much too small, which obliged me to make numerous turns, and in addition was handicapped by the public. My present apparatus, in its actual condition, can remain 24 minutes in the air at a speed of 50 miles an hour, and with the improvements that I shall make I am certain in a short space of time not to be far from establishing an hour's record, but of course not on the Issy-les-Moulineaux ground." Farman is now busy packing up his apparatus for shipment to Ghent in Belgium, where he is under engagement to attempt flights on an open ground admirably suited for record breaking. Delagrangé has left for Turin, Italy, in the hope of winning a pile of money for a fifteen-minute flight. Both Farman and Delagrangé are using their Voisin apparatus with which they have made all their flights in the neighborhood of Paris. Farman has the intention of modifying his cooling system so as to carry a much larger quantity of water, the small amount now carried boiling away in a few minutes, whenever the engine is not running satisfactorily. During the summer he should take possession of the Flying Fish, also built by Voisin, but engined by Renault, with which he believes something sensational can be done, owing to the great improvement in its capacity for staying aloft gained by the new motor.



## WM. E. METZGER'S CAT IS OUT OF THE BAG AT LAST

THE curtain has been raised on the "Metzger Mystery." It disclosed the Everitt-Metzger-Flanders Company, a million-dollar Detroit corporation, with B. F. Everitt, general manager of the Wayne Automobile Company, for its president; William E. Metzger, formerly of the Cadillac Motor Car Company, and still a large stockholder in the Northern Automobile Company, for its sales manager; and W. E. Flanders, once the Ford Motor Company's factory manager, now with the Wayne Automobile Company in the same capacity, at his old job of running the shop.

To give an idea of the financial strength of the new concern and at the same time let in some additional light on its genesis, it is to be noted that C. L. Palms, Dr. J. B. Book, W. T. Barber, Allen T. Bennett, of Port Huron, Thomas Walburn and E. Le Roy Pelletier are associated with the "big three," who lend their hyphenated names to Detroit's latest big automobile building enterprise. One may get a hint of the pushing policy to be pursued from Mr. Pelletier's being put in charge of the publicity, he having retired from the Maxwell-Briscoe Motor Car Company's advertising desk to assume it. Pelletier, by the way, is a considerable stockholder in the new company.

The campaign which will be inaugurated by the company calls for the production next season of 12,000 four-cylinder 30-horsepower cars. They will bear the nameplate "Everitt" and sell at not over \$1,200. The chassis will have a 103-inch wheel-base be fitted with a magneto, and have three or four styles of body equipment. Later other models are in contemplation. The Everitt will be a licensed car.

This deal, says Metzger, has so long been in contemplation

that a car of the proposed construction has already been built and so far tried out that sample machines will be ready by July 1 and shipments will begin in October.

The Everitt will be built at the factory of the Wayne company, which has been absorbed by the "big three," and probably at other big factories, in which Mr. Metzger is a large stockholder.

### Fair Women Guests at Trade Banquet.

By way of celebrating its birth, the Everitt-Metzger-Flanders Company, of Detroit, gave a dinner Tuesday night at the Café des Beaux Arts, New York. B. F. Everitt, president; W. E. Metzger, sales manager, and E. LeRoy Pelletier, publicity engineer, were present on behalf of the company, to personally extend its hospitality. A novel innovation for a trade banquet was the invitation to the guests to bring their wives or sweethearts. Many took the hosts at their word, and, accordingly, the banquet was graced by the presence of Mrs. E. LeRoy Pelletier, Mrs. E. P. Chalfont, Mrs. F. J. Wagner, Mrs. R. G. Betts, Mrs. R. B. Johnson, Mrs. R. A. Field, Mrs. E. W. Merrihew, Mrs. Joseph Gilbert, Mrs. John H. Gerrie, Mrs. Alfred Reeves, Mrs. Ward, Mrs. Roy McCardell, Mrs. A. B. Tucker and Miss Lasker. Gold hand mirrors were given the ladies as souvenirs.

The piece de resistance of the menu was frogs' legs, personally conducted from Detroit by Messrs. Everitt and Metzger. Benjamin Briscoe acted as toastmaster, and Messrs. Chalfont, Reeves, Everitt, Pelletier, Metzger, McCardell, Schwarzkopf, Gilbert and DeLisser were among those called upon for speeches. The guests numbered close to fifty.

### EVELAND TO HEAD TRADE ASSOCIATION.

NEW YORK, June 1.—The annual meeting of the stockholders of the New York Automobile Trade Association, Inc., was held at its headquarters in the Bryant Park Building this morning, and the following were elected as officers for the coming year: President, Frank Eveland, A. G. Spalding Brothers Company; first vice-president, General John T. Cutting, Oldsmobile Company of New York; second vice-president, E. C. Partridge, Wyckoff, Church & Partridge; treasurer, B. Blumenthal, West End Auto Palace; secretary and manager, Walter R. Lee. An amendment to the by-laws providing that all officers except the secretary shall be chosen from the members of the board of directors was unanimously carried, thereby increasing the latter from nine to twelve. The directorate, which was unanimously elected, consists of the following: C. Andrade, Jr., R. M. Owen Company; W. Harradon Victor Auto Storage Company; Richard Newton, Atlantic Motor Car Company; C. P. Skinner, Mitchell Motor Company; R. B. Van Dyke, American Locomotive Auto Company; Peter Fogarty; S. B. Bowman, S. B. Bowman Auto Company; and George Bennet, the White Company. The treasurer's report showed the association to be in a very prosperous condition.

### WALTER WHITE'S INJURIES NOT SERIOUS.

Walter White's injuries, received on the occasion of the hill-climb at Cincinnati last week, are proving not to be as serious as was at first reported, although they will keep him confined to the hospital for several weeks to come. Of the many conflicting stories that got abroad concerning the cause of Mr. White's mishap, none was entirely correct. It seems that in his practice spins, the driver of the White received a wrong impression as to where the finish line of the climb was to be, and did not discover his mistake, until coming up at better than a mile a minute, he saw the spectators banked where he expected to find the finish line. He managed to get across the line all right, but the turn beyond the car skidded and turned turtle.

### BOSTON DEALERS ELECT NEW OFFICERS.

BOSTON, June 1.—The annual meeting of the Boston Automobile Dealers' Association, Inc., was held to-day at the offices of the association, 5 Park square, and as there was much interest in the choice of officers the attendance was large. Reports were presented by the secretary and manager of the annual show, Chester I. Campbell; by Treasurer F. A. Hinchcliffe, and other officers and committees, after which the members proceeded to ballot for officers, the result being as follows: President, John H. MacAlman, agent for the Columbia; vice-president, J. S. Hathaway, manager the White Company; treasurer, F. A. Hinchcliffe, manager of the Winton Motor Carriage Company; clerk, Chester I. Campbell; directors, John H. MacAlman, J. S. Hathaway, F. A. Hinchcliffe, J. W. Maguire, of the J. W. Maguire Company, agents for the Pierce; A. P. Underhill, of the Reed-Underhill Company, agents for the Knox; Charles E. Fay, manager the Ford Company; C. F. Whitney, manager of the Park Square Auto Station, agents for the Berliet and the Stoddard-Dayton; E. A. Gilmore, of the Whitten-Gilmore Company, agents for the Thomas; and George H. Lowe, of the Lowe-Crawford Company, agents for the Crawford; secretary, Chester I. Campbell. Mr. Hathaway succeeds Mr. Lowe as vice-president. Messrs. Whitney and Gilmore are new members of the board of directors. At a meeting of the directors following the stockholders' meeting Chester I. Campbell was unanimously elected as manager of the Boston Automobile Show to be held in 1909.

### A CENTURY A DAY FOR ONE HUNDRED DAYS.

INDIANAPOLIS, IND., June 1.—With a century a day for one hundred consecutive days as its object in view, a Premier car started to-day on a brand new variety of long distance stunts. From to-day until September 8, the Premier Motor Manufacturing Company proposes to have its crew keep the car running, good weather or bad. The Premier will carry a full quota of passengers.

## BRIEF ITEMS OF NEWS AND TRADE MISCELLANY

A petition has been circulated among the Hartford, Conn., workmen to the effect that the city patronize home industry and purchase a Pope-Hartford ambulance, even though another maker would do the work for nearly 25 per cent. less.

Michigan's municipal executives are evidently very much taken with the merits of the Franklin, as within the last fortnight no less than three of them became owners of 1908 Franklin models. They are Mayor C. C. Green, of Battle Creek; the Mayor of Traverse City, and the Mayor of Muskegon, Mich.

As illustrating the longevity of Winton cars it is interesting to note that Charles Gorndt, of Cleveland, owns a 1900 single-cylinder Winton that outspeeds and outclimbs everything under 30 horsepower that he has encountered in his travels. Gorndt's single-cylinder measures 5 3-8 x 5 3-8 and is rated at less than 12 horsepower.

In making mention of the changes in the sales management of the Spare Motor Wheel of America, Ltd., in THE AUTOMOBILE last week, it was inadvertently stated that the sales department at 237 Michigan avenue, Chicago, was a branch house, while as a matter of fact, it is the main office of the company. The factory is located at St. Anne, Ill.

That the creditors of the Toledo Motor Car Company are in no wise in a hurry to realize on their claims against that company is shown in the fact that they authorized the receivers to reject an offer of \$500,000 for the plant as it now stands. F. A. Scott, of Cleveland, who was appointed receiver some time ago at the request of the creditors, is now making a complete inventory of the assets of the concern and his present judgment is that it ought not to be disposed of for less than \$800,000.

Even the claims of his constituents and the popular prejudice of the rural voter against having his representative in Congress mixed up with them "durned otto-mobeels," could not deter Speaker Joe Cannon from accepting the invitation of Congressman Landers to accompany him in a 40-horsepower Studebaker from Washington to Indiana. Others in the party who will participate in the two weeks' outing are Senator Hemingway, Mr. Buzby, secretary to the Speaker, an official cabinet photographer, and C. F. Redden, manager of the New York branch of the Studebaker Automobile Company. Refreshments for the party are being carried in a 30-horsepower Studebaker, which doubtless will not be lost sight of during the trip.

Just to show that the Detroit Electric could do it, George Bacon, chief engineer of the Anderson Company, Detroit, Mich., builders of the car, and P. Driscoll, of Harrisburg, Pa., the company's eastern sales manager, drove one of the Detroit cars from Washington to Baltimore under its own power. The distance is about 56 miles by road, but the achievement lies not so much in the distance covered as in the nature of the road, which is hilly and has a poor surface. The run was made on Monday and was repeated in the opposite direction the next day. The handy way in which the Detroit car did the trick resulted in the Dupont Company taking the agency for it in Washington. An attempt will be made on the Philadelphia-Atlantic City run later.

### NEW AGENCIES ESTABLISHED.

The Goodyear Tire & Rubber Company has just opened a new branch store at 2005 Euclid avenue, Cleveland, O., under the management of C. C. Hamerle, formerly connected with the New York office.

Michelin tires will soon be represented in Cleveland, the Michelin company having decided to open a branch store at 2001 Euclid avenue, next door to the new quarters of the Goodyear company. Richard Tracy will be in charge.

The Lancaster Automobile Company, Lancaster, Pa., agents for the Pope-Waverley and the Buick, have added the Franklin to their line, while the Kentucky Automobile Company, Louisville, Ky., has done likewise in its territory, and the De Long Machine Company, Shreveport, La., has made arrangements to handle the Franklin line exclusively.

A. A. Lederman, for the past four years assistant engineer of the George N. Pierce Company, Buffalo, N. Y., has just been appointed agent for the Pierce cars in central New York. Mr. Lederman has opened temporary offices in the Steward building, Utica, N. Y., pending the erection of a garage. The new agency will be known as the A. A. Lederman Company.

The Foss-Hughes Motor Car Company, Broad and Race streets, Philadelphia, Pa., has taken over the business of the Noblitt & Fassett Company, and in future will act as agents for the Pope-Hartford car. John H. Fassett, who was president of the latter concern, will be identified with the Foss-Hughes company, with which he severed his connections a few months previous, to take charge of the other concern.

### RECENT TRADE REMOVALS.

The Swinehart Clincher Tire Company's New York branch is now located in its new quarters at 875 Seventh avenue, near Fifty-ninth street, New York City. The entire building at the address in question has been leased by the Swinehart interests, thus permitting of the installation of much superior facilities than those available at the old place.

### PERSONAL TRADE MENTION.

Burt Morley, formerly with Hayden Eames and the Ferro Foundry & Machine Company, of Cleveland, O., has just been appointed manager of the Diamond Rubber Company's branch at Detroit, Mich.

W. N. Booth has just been appointed assistant manager of the Oldsmobile Company of Cleveland, the branch house of the Olds Motor Works, of Lansing, Mich. Ralph R. Owen is the branch manager.

E. B. Gallaher, manager of the American branch of the Maja Company, Ltd., returned last week from a flying trip to the other side, where he has been for the past three weeks on business connected with the Maja Company and the affairs of its American branch.

H. N. Anderson, formerly with the Dayton Motor Car Company, Dayton, O., has just joined the engineering forces of the Speedwell Motor Car Company, also of the same city. The latter concern now has a large new plant in the course of construction and its business is growing rapidly.

### NEW TRADE PUBLICATIONS.

Hartford-Suspension Company, Jersey City, N. J.—"Auto Comfort" is the latest comer to the field of automobile trade house organs. As its name implies, its mission is to tell of the comfort and safety derived from the use of the Truffault-Hartford shock absorbers, although it will naturally contain much other matter of interest to the autoist and driver. Copies will be forwarded for the asking.

Warner Instrument Company, Beloit, Wis.—A pamphlet on the speed-indicator question that will be found of considerable value and interest by autoists generally has just been issued by this firm, under the title of "The Final Truth About Speed Indicators." It is written in a plain, everyday, common-sense manner, and there are no unintelligible technical terms to confuse the layman, although the subject is one that is difficult to explain without the use of such aids. Copies will be forwarded gratis to autoists and drivers upon request.

Boston Gear Works, Norfolk Downs, Mass.—In addition to describing and illustrating the full line of gears of every description made by this firm, its catalogue, for 1908, which is more on the style of a handbook, also contains a number of handy tables of engineering data. It is an 88-page pamphlet in paper cover and contains a great deal of information concerning gears of every type in condensed form. In addition to gears, this firm also makes cast-iron grooved pulleys, star escape wheels, standard brass ratchets, heavy clock and motor springs, auto steering gears, chains, universal joints and the like.

Empire Metal Company, Syracuse, N. Y.—"Bearing on the Question" is the title of a booklet that has to do with bearing metals and particularly with "Empire" bearing metals. This concern has been in the business of making bearing metals for the past 28 years, so that its statement that no one alloy can be proper for all kinds of service may well be taken as the result of ripe experience. The numerous brands manufactured, such as "Genuine," "Silver Bronze," "Samson," "Motor," "Imperial," "Copper Hardened," "Triumph," and others, are described and the service they are intended for outlined. Another booklet from the same concern describes its silver metal galvanizing flux. It makes improved galvanizing possible at a decreased cost.

Oakland Motor Car Company, Pontiac, Mich.—One of the most interesting things in the catalogue of this concern, to the seeker after a car, is the little diagram to be found near its close. It is a simple affair, and not much space is given to it, but it shows better than several pages of argument could, how the annoying vibration of the two-cylinder vertical motor has been overcome in the Oakland power plant. Rather a novel and unusual feature of this catalogue are some reproductions of blueprints in natural tints, showing different views of the chassis and chief essentials of the car, drawn to scale. It is a 32-page pamphlet in buff covers, with the name Oakland embossed on them, and is an attractive piece of catalogue work, from the typographical point of view, as well as that of the man who is seeking information about the Oakland cars.

Stewart & Clark Manufacturing Company, Chicago.—One of the first things to greet the eye on opening the very attractive 1908 messenger of this concern is the ironclad five-year guarantee which the makers of the Stewart and American instruments give with every instrument they manufacture. This guarantee covers materials, mechanical construction and accurate operation of the instrument, flexible shaft and all connections, any instrument falling to give proper satisfaction or proving defective in material or construction during that period being repaired or replaced free of charge. Throughout the remaining 56 pages of the attractively illustrated catalogue the Stewart & Clark Company show the painstaking manner in which the instruments that can be covered by such a guarantee as this are made. There are no secrets about the Stewart and American speedometers, as every part is illustrated and its functions described. The book is printed on heavy surfaced paper in a most attractive style, while the illustrations, made from photographs, are unusually well executed. Nothing is left untold that those in search of speedometer information would wish to know.

### INFORMATION FOR AUTO USERS

**Volta High-Tension Magneto.**—This is an extremely simple type of high-tension magneto of the self-contained type that is now being put on the market by the Witherbee Igniter Company. As will be seen from the accompanying illustration, the Volta is of the usual permanent magnet type and is equipped with

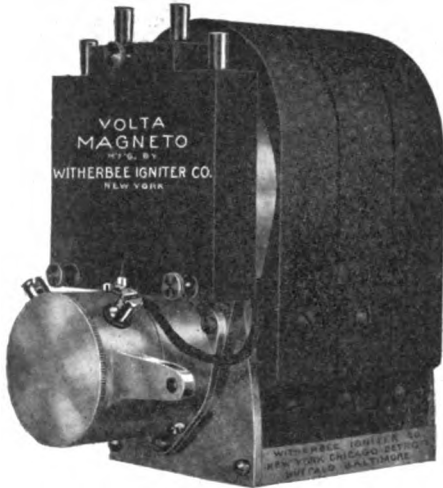

DISTRIBUTOR END, VOLTA MAGNETO.

a synchronous distributor. Both the armature and the distributor shafts are mounted on annular ball bearings so that even the small amount of attention ordinarily required for lubrication on such a machine has been further reduced, only two or three drops of oil per bearing being required each month. The construction throughout is of the most simple and durable kind. The same concern is also placing on the market the Wico storage battery charger, the Witherbee Igniter Company having procured the rights to manufacture and sell this

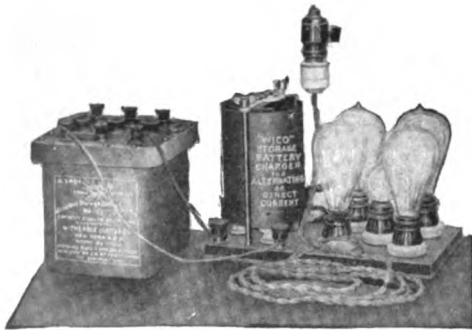

NEW WICO STORAGE BATTERY CHARGER.

charger from the inventor, M. R. Hutchinson. The illustrations show the charger connected to an electric light socket and a storage battery, the jar shown containing the alternating current rectifier. This changes an alternating current to a direct current, while the lamps cut the current down to the proper rate for charging. The small lamp shown is a pilot light to enable the state of the charge of the battery to be determined. By reversing the spring controlled switch forming part of the set, this five-ampere lamp is lighted and unless it burns brightly the battery is not fully charged. The entire outfit is designed to be carried on the car in the pressed steel containing case provided. It is extremely convenient for touring, and more than one set can be charged at a time.

**Rubberized Leather.**—This is a new departure in chrome tanned leather, insuring great strength and extra wearing qualities. It is being manufactured and marketed by the Gloversville Rubberized Leather Tire Company, Gloversville, N. Y., and is the result of a new secret process, which makes the material water resisting, as well as soft and pliable, always retaining its shape after wetting. It is especially adapted for the manufacture of leather tire and leather treads. This firm was one of the first to take advantage of the growing demand for a specially prepared chrome leather for automobile use, and the universal favor with which this has met from all tire, tread and casing manufacturers shows the step to have been well taken.

**Kinsler-Bennet Pin Universal.**—The Kinsler-Bennet Company, Hartford, Conn., have just placed a new universal joint of the pin type, designed especially for automobile use, on the market. It is composed of two yokes, four pins and an outer ring, it being possible to mount or take down all these parts without the aid of tools, as no screws or bolts are employed in the construction of this new universal joint. The yokes are held by the plate in such a manner that it is impossible for them to

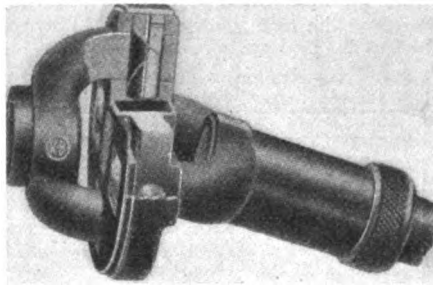

ASSEMBLY KINSLER-BENNET UNIVERSAL.

spread, while the outer ring holds the pins in position, and is itself held by two shouldered steel spring plugs, which also provide a means of oiling. In the center of the joint is a chamber holding a considerable quantity of oil. From this, the oil is fed through a hole in each pin connecting with outlets to all of the bearings so as to provide effective lubrication. All the working parts are of hardened steel, the yokes being drop forgings. This joint has been designed particularly with a view to use on automobiles where the service conditions are unusually severe, but it is also being marketed for machine tool use.

**"Long Arm System" Parts.**—The latest addition to its line of automobile parts, recently made by the Long Arm System Company, Cleveland, O., is a new set of steering reaches of the ball-socket and buffer type, which are now on the market.

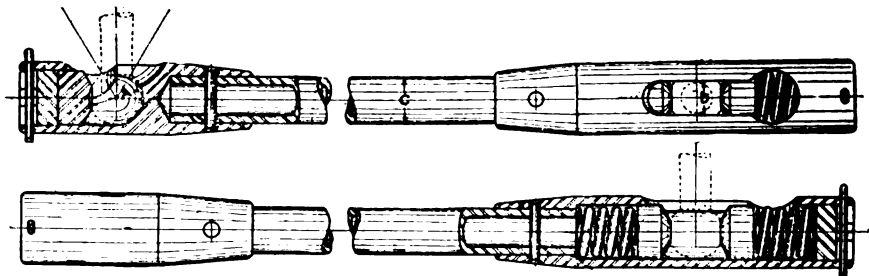

DETAILS OF THE NEW BALL-SOCKET AND BUFFER "LONG ARM" STEERING REACHES.

They are furnished in three sizes, suitable for 1, 1 1/8 and 1 1/4-inch balls, and are of interest chiefly for their simplicity which should make for great reliability in service. The accompanying sketch serves to show the general construction. The ball is securely held in the socket by the plug screwed in the end, and its retaining cotter pin. To avoid the fine pitch threads ordinarily used for similar plugs, requiring a more or less secure clamp to keep them from wearing loose with the constant pounding, and at the same time to provide a close adjustment for wear, a 12-pitch thread, tightly fitted, is used and close adjustment provided by an extra cotter pin hole in the socket case, as shown. This allows an adjustment of 1-12 turn, or 1-144 inch. The sockets are hardened and the buffer springs japped to prevent rusting. Heavy wrought iron pipe, pinned and brazed to the ends, is used for the center member. The reaches are furnished in any desired length.

**India Auto Oilstone.**—This is the latest addition to the very extensive range of oilstones for special purposes that is marketed by the Pike Manufacturing Company, Pike, N. H. It is intended particularly to replace the use of the file for keeping vibrator contact points in good shape, and as the makers put it, "the advantage of the new automobile oilstone over the file is the same as that derived in the use of an oilstone in the sharpening of a knife, instead of rasping it away with a file, the result, in the case of the file, leaving a rough surface, while the stone leaves the points polished and gives a very smooth contact." Another disadvantage of the file that will occur, even to the most inexperienced autoist, is the unnecessarily large amount of the costly platinum that is filed away, particularly when the points have been allowed to go for such a length of time without proper attention that they have become "pitted." A little regular attention with an India oilstone will keep them brightly polished and in the highest state of efficient working, as much of the skipping and missing of an engine is due to the poor condition of the vibrator contact points, although this is not always the cause that is suspected.



INDIA AUTO OILSTONE AND CASE.

# THE AUTOMOBILE



Finishing the Burst of Speed that Proclaimed the Hotchkiss the Star Performer of the Day.

STRAIGHTAWAY sprinting on an average American macadam highway had a renaissance on Hillside avenue, Jamaica, Long Island, Friday, June 5, in connection with the subway opening celebration, that might more properly be termed the inauguration of a new form of road racing in this country. Away back in 1901—November 26, to be exact—Henri Fournier made the first officially timed mile trial in a Mors machine, and set up a record of 51.4-5 seconds. That same day there were other trials by other classes of cars, including, by the way, a run by A. L. Riker in an electric racer. Old timers will remember standing in close lines as Fournier flashed by, missing the ignorant, foolhardy spectators and newspaper men almost by inches. Those trials on the Coney Island boulevard were the forerunners of another sprint meet, which took place on Staten Island on May 30, 1902, over a curved and ungraded course. The fatalities that were the outcome are a part of motor racing history, and resulted in sprint racing in this country being transferred to Ormond Beach. Since the Staten Island races there have been no sprint races to speak of on the public road beyond occasional minor attempts like those at Long Branch, Wildwood and Lowell. It is to be noted that that 51.4-5 seconds mile of Fournier's remained unbeaten until W. K. Vanderbilt, Jr., startled the world with his "39" at Ormond.

There have been annual sprint meets at Nice and Ostend, in

France, and several of lesser note in England, but not until Friday last had any series of straightaway short distance races been attempted in this country. It is a gratifying sign of the times that road contest promoters now look first to public safety, and that it is so generally admitted that the highways must not be used for racing, except when due precaution has been taken to guard the course by soldiers in long distance and by police in sprinting events.

The Long Island Automobile Club, which cooperated with the subway committee in the promotion of the affair and managed outright the racing itself, saw to it that due protective precaution was taken, and the city of Brooklyn backed them up with over 500 policemen and cycle cops, who knew just what they had to do. Enough said. So well did the guards do their work that 20,000 people saw the races with safety, pleasure, and convincing profit.

The course was a three-mile stretch, which was well oiled and rolled. It had two turns, but so gentle as to slow down the cars almost inappreciably. The mile racers had but a single curve to negotiate, and the kilometer sprinters none.

The outcome of the trials was not only a convincing demonstration of the speed possibilities of stock cars, but also an eye-opener to the progress that since Fournier's time has been made in the development of automobile speed. Even though the course, be it repeated, was but an average stone highway, figures

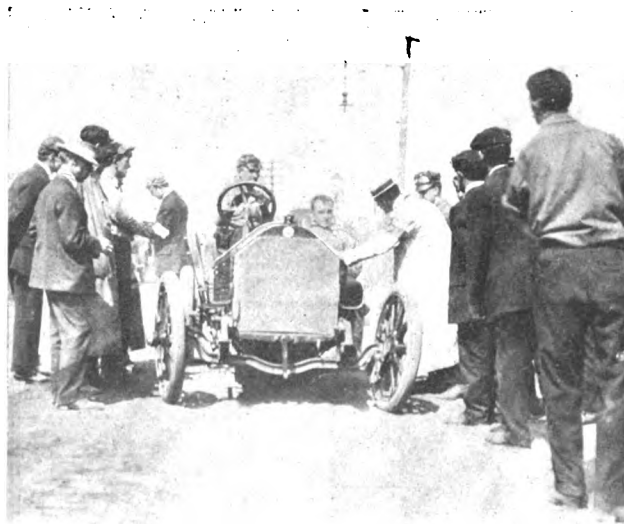

Isotta, Winner of the Stock Car Chassis Event.



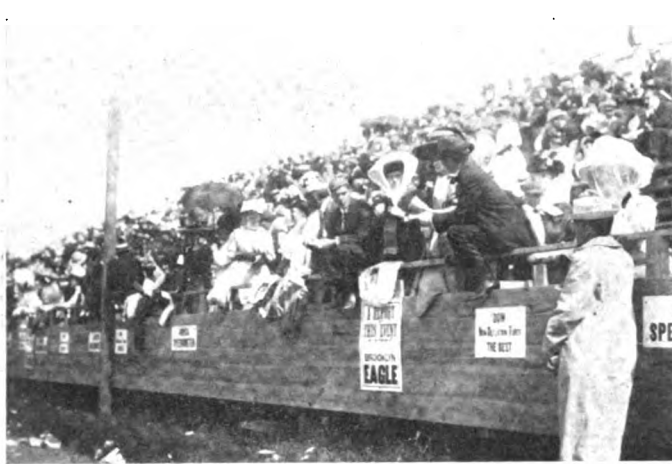

Scarcely a Vacancy in the Huge Grand Stand.

were set up that will compare favorably even with those achieved over the famous stretch of sand between Ormond and Daytona.

The king pin of the speeders proved to be the 120-horsepower Hotchkiss, which Elliot F. Shepard drove in the last Vanderbilt race, now owned by Harry Levey, an enthusiastic amateur, who came into the racing game at the last Ormond Beach race. With H. Kilpatrick at the wheel it scored 24 3-5 seconds for the kilo-



Part of the Decorated Parade That Was of Interest.

meter (90.93 miles per hour), 38 3-5 seconds for the mile (93.26 miles), and 1:19 1-5 for the two miles (90.90 miles).

The 20 seconds for the kilometer made by Guinness with a Darracq in France was not touched, nor was Demogeot's 58 2-5 seconds, made with the 200-horsepower Darracq on Ormond Beach, touched, but W. K. Vanderbilt, Jr's beach record of 39 seconds for the mile was beaten on this Long Island road, and



A Bunch of Hard-Working "Scribes" Looking Pleasant.

this best sets an estimate on the value of Friday's performance on Hillside avenue, Jamaica. This gives to Mr. Levey's car and driver American road records at all three distances and world's road records for the mile and two miles. The Ormond steam records for the mile and kilometer, 28 1-5 and 18 2-5, were naturally not approached.

In every event new stock car road racing records were set up to furnish standard marks, to be striven against at the future road sprint meets, which are bound to become popular and run in all parts of the country under adequate military or police protection.

The Isotta followed up its successes at Savannah and Westchester by evolving as the runner up to the Hotchkiss, the latter



The Acme, Winner of the \$1,251 to \$2,000 Class.

a specially built racing car, with a kilometer in 27 3-5, a mile in 42 4-5, and two miles in 1:28 4-5. It is to be noted that both the Hotchkiss and the Isotta were shod with Michelin tires.

The Fiat Cyclone sadly missed the pilotage of the late Emanuel Cedrino. George Robertson essayed the task and secured 30 4-5



Pennsylvania Car That Took Honors in Its Class.

for the kilometer and 46 2-5 for the mile. G. P. Parker, in a stock Fiat, attained a speed of 1:34 for two miles.

The class for four-cylinder cars over \$4,000 attracted much attention. In it the Stearns duplicated its recent Fort George hill climb success by landing four machines over the tape, one, two, three, four, in almost equally fast time.

Jefferson deMont Thompson, the referee, was forced to disqualify quite a bunch of cars in this class for not meeting entry blank requirements, but generously and happily cut the Gordian knot by offering special cups for those he had had to put outside the mast works. The Hotchkiss, Isotta and Fiat finished one, two, three.

The six-cylinder Mora, a make to be seen in the Vanderbilt Cup race, signalized its racing debut by winning the \$3,001 to

\$4,000 class. The Pennsylvania, whose speed was tipped so confidently at Savannah, made good by carrying off the \$2,001 to \$3,000 event. The Acme, another speedy Savannah contender, captured the \$1,251 to \$2,000 sprints. Among the little fellows under \$1,250 there was nothing to it but the Mitchell, which finished first and second. The six-cylinder race went to a Stearns, driven by a private owner, with 1:36 2-5, 45 seconds, and 28 4-5 seconds as its highly creditable string of performances. A Thomas "Six" was at its heels. The stock chassis (301 to 550 cubic inches piston displacement) was a merry scrap, the two miles going to the Isotta, and the kilometer and mile to the Simplex.

**Records Might Have Gone to Christie, But—**

A car with a record of 35 seconds for a mile made on Atlantic City beach was on hand. Walter Christie had entered his meteoric direct-drive racer in all the free-for-all events, with a very reasonable expectation of gathering with his American-made car the record honors of the day. But Christie is often unlucky at such critical times as these. He was this time. The day before Morton J. Seymour, who made a most noteworthy debut as a racing driver in the Briarcliff Cup contest, and had been engaged to pilot the car, met with an upset 24 hours previous, resulting in the demolition of the radiator.

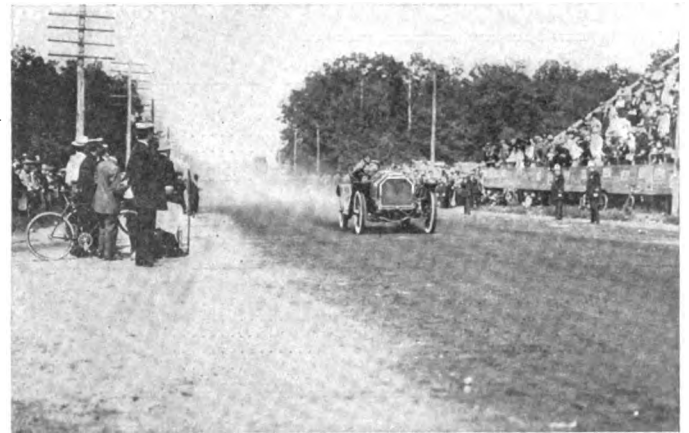

**Stearns That Triumphed in the Six-cylinder Trials.**

avenue developed speeds that were entirely unlooked for even by the old-timers, who had in mind all prior performances, and who realized how much more capable of getting over the ground modern cars are than their predecessors of several years ago. Seldom has such a crowd graced what was, after all, a purely



**How They Patiently Waited Back of the Line for the Crack of the Starter's Gun.**

Though Christie worked all night at the job he was unable to replace it, and so decided to console himself with a waterless try at the kilometer. In a cloud of smoke, and spurting great sheets of flame from the exhausts, the crippled car bore down the stretch in an effort to overcome its handicap and snatch a cup and a record also, perhaps. It was a game try, under a big handicap, and netted Seymour 26 3-5 seconds.

**Long Island Automobile Club Manages the Meet Well.**

With A. R. Pardington and his associates of the Long Island Automobile Club's contest committee at the helm, the details, as might be expected, were carried out with perfection. The timing was done by Alden L. McMurry's electric machine, the cars crossing wires connected with it at both start and finish, automatically starting and stopping the watches. S. M. Butler, Charlie Dieges and other members of the New York Timers' Club were on duty.

Fred J. Wagner, as usual, made a good job of the starting. With Harry Clinton, Mortimer C. Reeves and Tom Moon to help him, the cars were sent away so promptly that, despite the prophecy that the great number of contestants would not admit of a trial for all of them at all distances, the races were finished before seven o'clock.

It is safe to say that the Jamaica time trials will go down in history as one of the most successful events of the kind, and there is little doubt but that the numerous new records established on Friday last will require considerable beating before they go down before something faster, as the macadam of Hillside

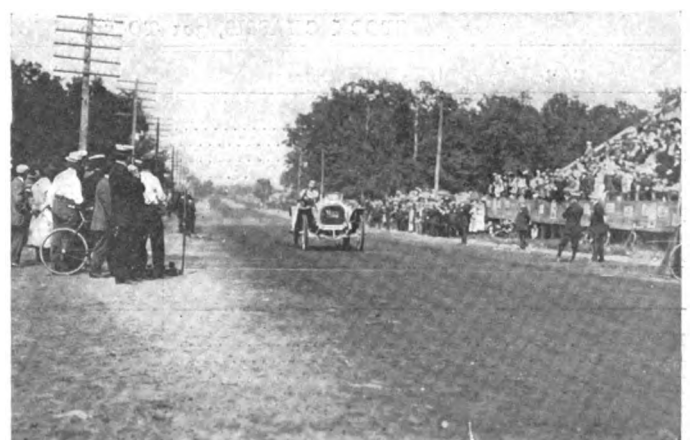

**Mora Winning the \$3,001 to \$4,000 Class Event.**

**GASOLINE CARS UNDER \$1,250**

CAR	Entrant	Driver	2 Miles		1 Mile	
			Time	Rate	Time	Rate
MITCHELL	Mitchell Motor Co.	O. R. Delamater	2:32	47.37	1:16 2-5	47.41
MITCHELL	Mitchell Motor Co.	C. P. Skinner	2:41 4-5	44.52	1:16 1-5	47.43
FORD	F. J. Nolte	F. J. Nolte	3:33	33.8	.....	.....
FORD	R. J. Johnston	R. J. Johnston	4:16	28.12	1:30 1-5	40.10

**GASOLINE CARS, \$1,251 TO \$2,000**

CAR	Entrant	Driver	2 Miles		1 Mile		Kilometer	
			Time	Rate	Time	Rate	Time	Rate
ACME	Acme Motor Car Co.	C. A. Patschke	2:07	57.09	1:03 3-5	57.	38 3-5	57.95
P. & S.	K. R. Manzille	K. R. Manzille	2:22 4-5	50.04	1:07 3-5	53.45	42 3-5	52.51
HAYNES	W. E. Shuttleworth	W. E. Shuttleworth	2:23	50.02	1:08	52.94	42 3-5	52.51
CADILLAC	J. D. Rourk	J. D. Rourk	2:27	49.10	1:12 3-5	49.52	43 1-5	51.78
JACKSON	G. J. Scott Motor Co.	Robt. Burman	2:29	48.30	.....	.....	44	50.84
MITCHELL	Mitchell Motor Co.	W. Olney	2:31	47.18	1:12 1-5	49.95	.....	.....

**GASOLINE CARS, \$2,001 TO \$3,000**

CAR	Entrant	Driver	2 Miles		1 Mile		Kilometer	
			Time	Rate	Time	Rate	Time	Rate
PENNSYLVANIA	Penn. Auto-Motor Co.	L. Zengel	1:53	63.7	55	65.45	34	65.79
CORBIN	Corbin Motor Vehicle Corp.	J. W. Swan	1:55 4-5	62.60	57 1-5	62.93	35 2-5	63.19
PULLMAN	Cimiotti Bros.	Robt. Morton	1:56 1-5	62.06	56 4-5	63.38	35 1-5	63.55
PULLMAN	Cimiotti Bros.	J. A. Kline	2:08	56.25	1:03 3-5	56.60	39 3-5	56.48
POPE HARTFORD	A. G. Southworth	Philip Hines	2:08 3-5	56.05	1:02 2-5	57.69	38 2-5	58.25
FORD	Bishop, McCormick & Bishop	Joseph Henry	2:10 4-5	55.30	1:05	55.38	44 3-5	50.15
MIDLAND	Allenhurst Garage	"Deacon" Holmes	2:35	46.50	1:12	50.	.....	.....
IMPERIAL	H. H. Tredwill	W. H. Owen	2:58	40.45	1:08 1-5	52.78	42	53.26

**GASOLINE CARS, \$3,001 TO \$4,000**

CAR	Entrant	Driver	2 Miles		1 Mile		Kilometer	
			Time	Rate	Time	Rate	Time	Rate
MORA	Mora Motor Car Co.	J. V. Dowd	2:08 2-5	56.05	.....	.....	.....	.....
CLEVELAND	Cleveland Motor Car Co.	W. A. Woods	2:12	54.54	1:28 2-5	40.63	35 4-5	62.48
THOMAS	T. F. Chesebrough	T. F. Chesebrough	.....	.....	57 1-5	62.93	.....	.....
STEVENS-DURYEA	J. M. Allen Co.	P. J. McDermott	2:16	52.94	1:08	52.94	42	53.26

**FOUR-CYLINDER CARS OVER \$4,000**

CAR	Entrant	Driver	2 Miles		1 Mile		Kilometer	
			Time	Rate	Time	Rate	Time	Rate
STEARNS	Allen-Swan Co.	Halstead Swan	1:48	66.66	52 4-5	68.18	33 4-5	66.18
STEARNS	Allen-Swan Co.	D. E. Farrell	1:49	66.08	52 4-5	68.18	33 1-5	67.37
STEARNS	Caleb Bragg	Caleb Bragg	1:51	64.88	51 2-5	70.03	35	63.91
STEARNS	James Doig	James Doig	1:55 1-5	62.	54 2-5	66.17	34 2-5	65.02
MERCEDDES	E. R. Thomas	H. Johnson	1:54	63.15	54	66.66	33 4-5	66.18

**SIX-CYLINDER CARS OVER \$2,500**

CAR	Entrant	Driver	2 Miles		1 Mile		Kilometer	
			Time	Rate	Time	Rate	Time	Rate
STEARNS	C. F. Alcott	C. F. Alcott	1:36 3-5	74.38	45	80.	32 4-5	79.32
THOMAS	E. F. Buchanan	E. F. Buchanan	1:49 1-5	66.42	52 1-5	68.96	32	69.90
ACME	Acme Motor Car Co.	C. B. Rogers	1:52 2-5	64.28	.....	.....	.....	.....
HOTCHKISS	C. F. Steppani	S. Carouso	1:53	63.15	58 2-5	61.64	37 4-5	59.17
MORA	Mora Motor Car Co.	J. V. Dowd	2:24 1-5	50.	1:06 1-5	54.40	.....	.....
FORD	J. P. Disbrow	J. P. Disbrow	2:00 3-5	59.40	59	61.01	36 1-5	61.79

**FREE-FOR-ALL**

CAR	Entrant	Driver	2 Miles		1 Mile		Kilometer	
			Time	Rate	Time	Rate	Time	Rate
HOTCHKISS	Harry Levey	H. Kilpatrick	1:19 1-5	90.90	38 3-5	93.26	24 3-5	90.93
FIAT CYCLONE	Fiat Auto Co.	G. Robertson	1:51 4-5	64.98	46 2-5	77.58	30 4-5	72.62
AMERICAN	Stewart Elliot	W. H. Owen	.....	.....	58 4-5	61.22	37	60.45
ISOTTA	C. V. Brokaw	J. Lang	.....	.....	42 1-5	85.30	27 3-5	81.05
FIAT	Fiat Auto Co.	G. P. Parker	.....	.....	47 3-5	75.63	28 4-5	77.67
CHRISTIE	Walter Christie	Morton Seymour	.....	.....	.....	.....	26 3-5	84.09

**STOCK CHASSIS, 301 TO 550 CUBIC INCHES PISTON DISPLACEMENT**

CAR	Entrant	Driver	2 Miles		1 Mile		Kilometer	
			Time	Rate	Time	Rate	Time	Rate
ISOTTA	C. V. Brokaw	John Lang	1:29 1-5	78.94	.....	.....	.....	.....
FIAT	Fiat Auto Co.	G. P. Parker	1:32 4-5	77.58	.....	.....	.....	.....
SIMPLE X	Palmer & Singer	J. M. Seymour	1:44 3-5	68.96	51	70.58	32	69.90
PENNSYLVANIA	Penn. Auto-Motor Co.	L. Zengel	1:46 4-5	67.66	51 1-5	70.31	32 3-5	68.61
PENNSYLVANIA	Penn. Auto-Motor Co.	A. Gentile	1:55	62.71	57 3-5	62.50	37	60.45
MERCEDES	Broadway Auto Ex.	H. A. Hawkin	.....	.....	.....	.....	44	50.84

**SPECIAL CLASS FOR DISQUALIFIED CARS**

CAR	Entrant	Driver	2 Miles		1 Mile		Kilometer	
			Time	Rate	Time	Rate	Time	Rate
HOTCHKISS	Harry Levey	H. Kilpatrick	1:20 1-5	90.25	.....	.....	.....	.....
ISOTTA	C. V. Brokaw	John Lang	1:28 4-5	81.08	42 4-5	84.11	.....	.....
FIAT	Fiat Auto Co.	G. P. Parker	1:34	76.59	46 3-5	77.25	.....	.....
AMERICAN	Stuart Elliot	W. H. Owen	1:40 4-5	71.42	52	69.23	.....	.....
ALLEN-KINGSTON	W. C. Allen	Ralph De Palma	1:45	68.70	52 2-5	68.44	.....	.....
MERCEDES	H. E. Trevor	H. E. Trevor	2:08 4-5	56.05	1:04 1-5	56.07	.....	.....
PEERLESS	Jack Rutherford	Jack Rutherford	1:56 1-5	52.94	.....	.....	.....	.....



Vice-President and General Manager Pardington Turns the First Spadeful of Earth.

WITH the turning of the first spadeful of earth at Central Park on Saturday by A. R. Pardington, general manager of the Long Island Motor Parkway, Inc., acting for its president, W. K. Vanderbilt, Jr., who was kept by illness in his family from participating in the formal start of the work on the project so near to his heart, the long dream of automobilism for a stretch of road of its own on which cars may be driven at their utmost speed without danger to the general public is assured of realization.

A simple yet impressive and appropriate ceremonial had been arranged in celebration of an event so momentous to the motor car world, not only of New York but of the country at large. There were a few speeches by men who were well entitled to make them, and then following the tossing of the first spadeful of earth carts invaded the spot, a score of laborers attacked the soil with pick and shovel, and a stick of dynamite blew high in the air an impeding tree. An epoch in automobilism was inaugurated. An example was set which it is safe to predict other cities and populative centers will not be long in following.

Despite the fact that the place chosen to begin the work on the parkway was remote—a spot on the Jerusalem road near Central Park, some 30 miles from Long Island City and five miles from Jericho, on the previous Vanderbilt Cup courses—fully a score of automobilists from New York and surrounding towns were on hand with their cars to participate in the celebration. On a raised platform was a full band, which, previous to the ceremonies, gave a concert. The historic spot was roped in. Fringing the ropes were the automobiles and crowding them were several hundred Long Islanders, who had come afoot to witness the start of a work that will mean much to their prosperity.

Sharp at 3:30 o'clock, the time set for the beginning of the ceremonies, Mr. Pardington stepped to the front of the platform, and in an address all too modest gave more than the lion's share of the glory of the parkway achievement to Mr. Vanderbilt, expressed with emotion his regret that the president of the company had been kept away by serious illness in his family, and begged leave to read a brief address prepared by Mr. Vanderbilt, by way of expressing his feelings on the occasion:

We are here to-day to celebrate the commencement of work on a road, which, when completed, will give to the world one more mode of transportation. There have been in the past highways for all kinds of vehicular traffic, canals for the movement of freight, railroads for the transportation of passengers and trolleys for the convenience of those living in the suburbs of our larger cities, but in no case has the motorist been considered.

Although but a few years in existence, the automobile has come

into such prominence that it has revolutionized all modes of travel. Distance has been eliminated, highways improved, unknown districts opened up, and pleasure given to thousands.

Judge William H. Hotchkiss, president of the American Automobile Association, was next introduced as one who had been a great friend of the enterprise from its inception. The judge dilated eloquently on the value of organization, and on the benefits the building of such parkways would be, not only to automobilism, but to the general public as well. He said:

On behalf of the militant motorists of the nation, the twenty thousand who have organized that they might the better combat prejudice and the sooner compel fair treatment, on behalf of yet other thousands to whom a road restricted to automobiles is like a glimpse of paradise, on behalf of all the men who recognize in works like these the seven-leagued boots of Giant Progress, I congratulate you—I congratulate Mr. Vanderbilt, who conceived this enterprise, and you, gentlemen of the Parkway Company, who have assisted in carrying it through; and not the least, believe me, our old friend Pardington, who, six years ago, was in

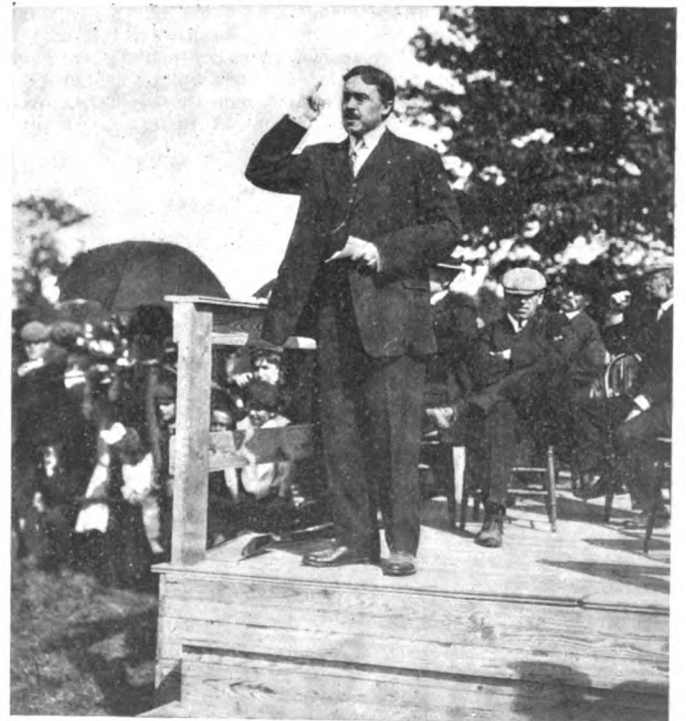

President Hotchkiss of the A. A. A. Making His Address.



To pierce the ether's high unknown dominions,  
To reach new spheres of motor activity."

his time must bide our time. The motor vehicle will remain terrestrial throughout our generation.

So, hall, the first motor parkway! And all hail, those pioneers—Mr. Vanderbilt and his associates—who, for the motorists of America and the world generally, are here blazing the trail for the motor roads, the motor streets and the motor bridges of the present motor age.

The next speaker was August Hecksher, a director of the parkway, also a highway commissioner of Huntington. Mr. Hecksher's theme embraced the wonderful progress in transportation during the past year, notably the building of the East river bridges and the completion of the tunnel all the way from City Hall, New York, to Jamaica. He characterized the parkway as an innovation which would prove almost as valuable to Long Island and New York as the bridges and tunnels themselves.

Milton L'Ecluse, a director of the Long Island Real Estate Exchange, dwelt on the great benefits the parkway would bring to Long Island in the way of attracting not only visitors but permanent residents along its line.

John C. Wetmore, speaking for the New York automobile writers, congratulated automobilism and Long Island that their dream was at last to come true and prophesied that some day the fraternity and Long Islanders would erect a monument on the parkway to its promoters, and that high up on it would be the names of Vanderbilt and Pardington.

The speechmaking was brought to a close by Russell A. Field, secretary of the Long Island Automobile Club, who spoke eloquently of the interest of the club in the parkway, and concluded with a glowing tribute of congratulation to the directors that they had secured one of their members, A. R. Pardington, to manage the enterprise. He said in part:

The beginning of this great boon to the motor-driven vehicle is certainly a welcome day to the Long Island Automobile Club and the newspapers in this vicinity. It will, from the turning of the first shovel of earth, give both something to talk and write about for generations to come.

This is no ordinary project, the inaugural of which we are here to honor and to witness. It is a most extraordinary and stupendous undertaking, the first private and exclusive automobile roadway to be built in the world. The engineers who, after months of research and thought, have worked out the details of this great motor highway, have written a text-book, the coming of which half the nations of the earth, who realize the necessity of such roads, have been waiting.

Before the races for the Vanderbilt Cup Long Island was to many people but a strip of land extending eastward from Brooklyn to Montauk point a hundred miles or more. The international struggles among the best cars Europe and America could produce, brought people to this island, revealed the multitude of its beauty spots, called attention to its advantages, brought desirable purchasers of its lands and good money into the pockets of its citizens. How much more then will the coming of this specially built highway redound to the lasting benefit and good of Long Island. Sixty-five miles of unexcelled going, stretching snake-like from Garden City to Riverhead, over hill and down dale, by lake and river, where the power possibilities and the requirements of safety are the only limitations to speed.

The mind breaks all records in contemplating this scene of motor contentment. Speed is one of the assets of the motor car, of the same relative value as are its other superiorities over all other means of transportation. It is as natural for an owner to want occasionally to speed his machine and perhaps to match it



A Part of the Big Crowd that Witnessed the Ceremonies.

at the birthing of that now thriving body for which I particularly speak, the American Automobile Association.

The occasion is epochal. When, long years ago, the mounted traveler on the public ways gave place to the stage coach, the first English turnpike was constructed—the stage coach road of our great-grandfather's great-grandfather. Then came the primitive steam car, and the man of 1830 thought to build a road to fit the new conveyance. They tried, and failed; the steam car took to the rails, and it now has rail-roads of its own. The roads of the stage coach remain stage coach roads still.

But now comes another self-propelled vehicle, a steam car in miniature, light, easily operated, reasonably safe in mature hands, but capable of great speed. It, too, has taken to the stage coach roads, but, unlike the steam car, it intends to stay there. It needs no rails; the stage coach road, brought up to date, is enough.

Enough, did I say? Not everywhere. In territories such as this—the neighborhoods of great cities and the districts of vast country estates and popular resorts—motor roads, limited to the new vehicle, especially constructed for it, like the railroads' private enterprises of a public nature, have become necessary, and the Long Island Motor Parkway is the first of such roads anywhere in the world. Here, to-day, then, the motor vehicle, as it were, takes to its rails, this parkway becomes the younger brother of the railroad, and the men back of it are as truly pioneers as those who stage-coached on rails behind the "DeWitt Clinton" from Schenectady to Albany nearly one hundred years ago.

The occasion is epochal in another sense. It is prophetic. If motor roads are necessary—and who here will deny it—how soon will it be before we need motor streets? Nay, do you not need them in New York now? And, if streets, bridges; and, if bridges, tunnels and subways? Indeed, the day seems not far distant when our great cities, particularly the metropolis, yielding to the demands of a majority of the people—for, before many years have elapsed, a majority will drive motor cars—will build elevated steel pavements up and down and across their main thoroughfares, over the necessary bridges, and connecting up at their termini with roads like this.

If such be the ultimate of this occasion, not a man here but will look back upon it with pride and gladness that he was present. Yes, even though, peering into the future through the binoculars of the Aero Club, and paraphrasing Faust, he boasts:

"A fiery chariot, borne on buoyant pinions,  
Sweeps near me now. I soon shall ready be



Workmen Getting Busy After the Speechmaking Ceased.



Racing Board Chairman Thompson Was Attentive.

against that of his neighbor as it is for a boy to run a race with his playmate, or the horseman brush with his fellow admirer of equine beauty on the speedway.

Users of the public highways have been travelling for centuries in a machine-like, mechanical sort of way, undisturbed, careless and oftentimes stupid in their driving, and it will take some time for them to awaken to the quick thought and keen perception necessary for the successful handling of any vehicle in this era of the motor. Until the time when they shall be so educated automobiles must have special parkways like this where the average owner may drive unhaunted by the specter of hidden speed traps, where the maker may thoroughly try out his creations to determine what points should be improved, where the dealer may demonstrate the stamina and speed boasted in the highly executed catalogues. We shall then realize the difference between 65 and 75 miles an hour. The Parkway may become a missionary of truth. If so, then so much the better.

There is another important phase of this great motor highway on which actual work is being started to-day, that is the practicability as a means of every-day travel from country home to business and back again in cleaner manner and faster time than existing railroads can furnish. The value of the real estate which will be in demand as home sites with the coming of the Parkway cannot be estimated.

The Long Island Automobile Club takes a warm and rather personal interest in the Parkway because the general manager so wisely selected by you is one of the men responsible for the formation of that club. We know A. R. Pardington to be a man among men, with unbounded energy, an unusual capacity for handling details, a beautiful sense of fairness and right, in short, the king pin for such an organization as yours.

It is a pleasure to state that during the preparatory period of the Parkway, when little news of progress was given out, not one of the Brooklyn newspapers ever thought or intimated that

the road would not be built. A. R. Pardington was the general manager. He stated the project would certainly be carried through to completion, and, although readers were periodically served the same initial story with different garnishes, we were confident that such a day as this would come, when the result of his efforts and your efforts would burst into blossom and bear fruit.

The Long Island Automobile Club is as anxious and restless as you gentlemen for the completion of the Parkway. On the minutes of the organization month after month have been spread many questions regarding its progress. The members who have come here to-day will take great pleasure in seeing recorded the fact that the great project has actually been begun.

The Long Island Automobile Club wishes you godspeed in this work, it prays that neither commercial nor financial troubles may interrupt its progress, it sincerely hopes that accidents during and after its completion may be unknown, that success shall crown the efforts of those men who have believed in and loved Long Island enough to make the Parkway possible. These sentiments are, I know, not only echoed by the newspapers, but by every resident of Long Island.

Then once more expressing his regret that the one who should rightly have had the honor was absent, Mr. Pardington drove a nicked spade deep into the sod, the band played, the crowd cheered, and the parkway was started. A rush of carts and laborers within the roped enclosure followed. Picks swung, shovels waved, and a Niagara of dirt fell into the wagons. A loud explosion of dynamite, a cloud of dirt and chips, and a tree had been blown from the parkway's path.

The place of beginning is about the center of an eleven-mile stretch, whose completion is guaranteed by contract in October, in ample time for practice for the Vanderbilt Cup race.

## FIRST VANDERBILT RACE FOREIGN ENTRY A MERCEDES

THE first formal entry of a foreign car for the Vanderbilt Cup race has been made. It is a 90-horsepower Mercedes. In fact, it is the same car which Janatzky drove in the last international race on Long Island. Its entrant is Robert Graves, a member of the Racing Board, who has made former entries of Mercedes to these races. The making of the entry was a feature of the visit of the newspaper men and others to Mr. Graves' automobile lodge at Mineola, following the motor parkway inaugural ceremonies on Saturday. At the conclusion of the

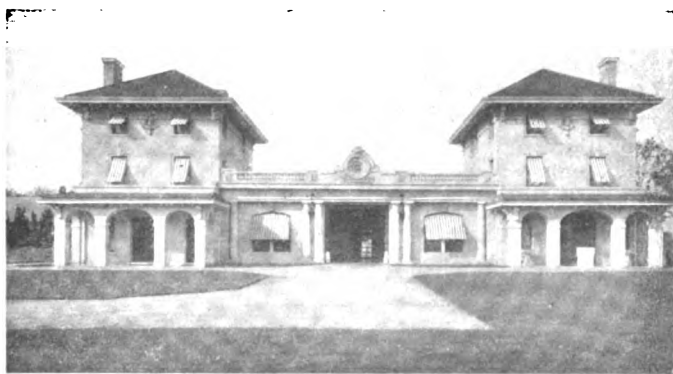

Automobile Lodge of Robert Graves at Mineola, Long Island

luncheon the host of the occasion handed to Jefferson deMont Thompson the entry, accompanied by a check for \$1,000 for the entry fee. "I have not named a driver," said Mr. Graves, "but I am going over to the Grand Prix to secure one." I have a bug in my bonnet, by the way, to also enter an American car, for I can see nothing in the rules to prevent making more than one."

Mr. Graves in building this private garage has set an example which may be a precedent among enthusiastic followers of the sport. It is more than a mere garage. It is an exclusive automobile lodge for the entertainment of motoring parties. It will also be a garage for the big stable of racing cars he is to establish at this convenient point, which is less than a quarter of a

mile from the beginning of the parkway.

Reposing against a background of stately green cedars the soft gray concrete walls of this restful retreat are livened up here and there by heavy tile roofs of rich red. The dainty proportions and clean outline of the structure, which is purest Spanish Colonial in design, suggests to the eye of the beholder a gem of pearl in a sea of velvety emerald lawn. Two wings, each a complete building in itself, with sloping tile roofs over their three stories and with further dashes of the same rich deep blood-red in the tile roofs of their gracefully arched porches, are connected by a long stretch of columnar façade, making a spacious car room, with machine room behind.

The west wing of the building is used as living quarters by the owner and his guests, and in the east wing are numerous rooms for employees, a complete stable, and carriage room on the ground floor for casual visitors from across country.

For beauty of design and convenience of arrangement the building surpasses any structure heretofore erected for an owner's private use. The owner's desire was to provide numerous original contrivances which his own ingenuity and extensive familiarity with the machine convinced him as being essential.

From extensive glass skylights over the large car room and machine room the entire garage is bathed in floods of beautiful golden light. There is installed an electric clock, with adjustable time set and switches in the owner's quarters, controlling simultaneously in each guest's and chauffeur's bedroom electric lights and alarm bells for arousing the slumberers to the fray.

## CHADWICK SIX FOR THE VANDERBILT CUP RACE

PHILADELPHIA, June 9.—Although it is stated that the makers of the Chadwick car, the Chadwick Engineering Works, had decided to be represented in the Vanderbilt some months ago, official announcement to that effect is just made public. H. B. Larzelere, the company's sales manager, states that the announcement was deferred until an opportunity could be had to show what the Great Chadwick Six could do, this being presented by the recent Giant's Despair and Dead Horse Hill climbs, in which it triumphed in no uncertain manner.

## ORPHANS' DAY'S FOUNDERS CELEBRATE

**T**HANKS to the institution of Orphans' Day by the New York Motor Club, the hustling promotion of the affair by Automobile Row dealers, and the added liberality of owners in also contributing cars and money, this greatest of motor car charities was celebrated in this city on Tuesday, with as much success as ever. Fifteen hundred boys and girls from ten of the city's orphanages were given a ride in 150 automobiles and motor

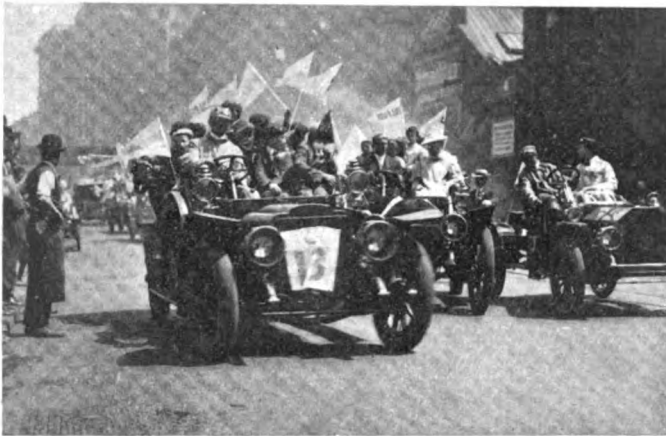

Where the Parade Started on Broadway at 54th Street.

trucks to Coney Island and a whole day of revel at Luna Park.

With the New York Motor Club, the originator of the idea in this country, in a temporary and perhaps transitory trance and Sam Miles, who has been stepfather and head nurse to the little ones at former celebrations, touring in Europe, it looked pretty dark for an Orphans' Day outing in this city this year. "Senator" Morgan, in whose fertile brain this charitable function originated, however, came to the rescue, and, with characteristic hustle, soon had a Committee of Fifty signed to his promotion pledge and a resultant meeting called. The good fellows of Automobile Row responded very generally and promptly put the necessary committees to work in charge of Alec Schwalbach.

Some of the leaders thought it would be an efficient policy, in view of the eleventh hour rush, to put through the affair on a "bluff," based on the number of cars the tradesmen thought they could recruit among their customers. As the day drew near both money and cars were alarmingly lacking, and then appeals and personal canvasses were tried. The old method proved effective and saved the day.

Up to the eve of Orphans' Day, however, though Automobile Row had contributed its cash as well as cars liberally, the food

problem faced the committee. Who was to supply the luncheon, as Sir Thomas Dewar, George Kessler and Col. Clifton had done at the three previous celebrations?

Late Monday afternoon, however, a Baron Bountiful was forthcoming. Ray M. Owen, sales agent for the Reo and Premier, called up headquarters, inquired into the finances, and offered to stand treat himself to the 1,500 little ones.

At ten o'clock the four streets from 54th to 57th west of Broadway were filled with automobiles and motor trucks filled with happy, laughing boys and girls, packed away like sardines in a box, so that as few as possible would have to be left at home. In fact, 150 larger children were sent down to Luna Park by the subway and elevated lines. Half an hour later the parade got under way down Broadway, across 48th street to Fifth avenue, and thence to the Bowery. At Mott street ten cars bearing 150 Italian orphans joined the procession and went with it across Williamsburg Bridge, through Prospect Park and down the



At Coney Island the Youngsters Had a Glorious Time.

Coney Island Boulevard to Luna Park, whose management threw open its gates free to the children.

After a hearty luncheon the orphans stormed the many shows, shot the chutes, slid the slides, and saw the sights of the wonderland of which for weeks they had dreamed.

And yet there were close to ten thousand of the little ones left at home because but 150 of the 10,000 automobile owners of New York thought it worth while to give the city's orphans a ride in a motor car and a day at Coney Island. Ask the 150 whether they got their reward.

## THOMAS PROTESTS PROTOS AND DEMANDS THE CUP

**A**LTHOUGH matters have been considered as settled by the decision of the French committee to allow the German car to continue with a 30 days' penalization, no objection to the decision of the committee having been made at the time it was promulgated, the Thomas company has filed a further protest against the German car, on the ground that, in view of the much greater mileage covered by the Thomas, it is not fair for it to compete against the German alone. A formal demand for the cup is accordingly made by E. R. Thomas.

Late advices from Pograditch, via Nikol'sk, Siberia, received by the *New York Times*, show both of the remaining competitors to be having a pretty strenuous time of it. The

Protos was wrong side up at the bottom of a gully after it had taken to the road, through being forbidden to further use of the railroad right of way, and the Thomas was proceeding on the tracks with a railroad official, followed by a hand car carrying a telegrapher, a crew of coolies and a supply of planks to bridge unballasted stretches. This was after a three-day delay caused by the Thomas stripping its driving gears through running over unballasted ties, Schuster having to take the train to Harbin for replacement parts. Grand Duke Serge Nicholovitch, one of the Russian committee, has just been through the territory now being traversed by the cars, and has ordered that every assistance be given them.

# LUBRICATION ON THE MODERN AUTOMOBILE

By ARTHUR H. DENISON.

IN the modern gas engine there are moving parts subject to very high temperatures and pressures, and this has naturally brought about the development of lubricants suitable for these conditions. Lubricating oils are one of the products of crude oil or petroleum, either volatilized by the action of heat or separated by other methods. The operator of a car does not need to know the chemical composition of oils or the refining operations necessary to their manufacture, yet knowledge of the necessity for oils, and the many places where they are needed is

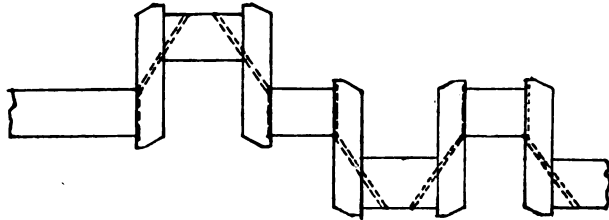

Fig. 1—Section of crankshaft for four-cylinder motor, having five main bearings, and showing one method of drilling shaft to lubricate connecting rod bearings.

absolutely necessary to insure the auto's successful operation.

The primary value of an oil is its ability to keep the two surfaces it is intended to lubricate separated, thus reducing friction. Friction is present in all moving objects and in machinery is due to minute irregularities in both surfaces, which, when viewed under a microscope, seem rough like files. Extracts from the laws of friction that need to be considered here are, "Friction varies with pressures, increases with the roughness of the surfaces, and is diminished by polishing or lubricating the surfaces. Considering the law—"Friction is diminished by lubricating the surfaces;" a suitable oil will both fill the minute irregularities and maintain a film between the two surfaces, preventing them from actually coming in contact. There is always pressure on a bearing, and the effect is a tendency to separate the molecules of the lubricant, forcing enough out from between the surfaces to allow the metals to come in contact. The value of an oil, therefore, is its ability to resist the tendency to be forced out of the bearing. In opposition to this tendency to separate the molecules is the force termed cohesion, or in oils, viscosity, meaning the attraction of one molecule for another; consequently the higher the viscosity of an oil the more suitable it is in bearings subject to heavy loads.

Friction always generates heat and an increase of one degree causes a proportionate increase in volume, the molecules of the substance being driven further apart and the force of cohesion lessened. If the temperature is raised sufficiently and the substance vaporized, the force of cohesion is overcome entirely. The manufacturer of oils to-day provides different grades for almost each class of work. Oils intended for use in machinery, such as sewing machines, bicycles, guns, etc., are not subject to heavy loads or heat, therefore, the composition of the oil is determined with regard for these conditions. Oils for steam engines must withstand the temperatures and pressures of steam, that of saturated steam, or of steam in contact with water, is about 225 degrees F. The flashing point of these oils is so low that when subject to the temperatures of the gas engine they would be readily decomposed.

## Oils of High Flash Point Are Required.

The temperature of the burning gas, during the time combustion is in progress, is estimated at 2,500 degrees F. and upward. The melting point of cast iron such as the material in the cylinders is between 2,200 and 2,300 degrees F. On the other hand, the oil and cylinder walls are subject to these temperatures for a very short period of time, in a motor of 5-inch stroke, running

at a speed of 600 r.p.m., the length of time the maximum temperature would be maintained is approximately 1-40 of a second.

Taking into consideration the cooling influence of the water jacket, also that of the gas introduced on the suction stroke, the average temperature of the cylinder walls is estimated at about 500 degrees F. Fluids are poor conductors of heat, consequently the oil film on the cylinder walls protects the cylinders to a certain extent. The best temperature of the water, in water-cooled engines has been ascertained to be about 210 degrees F., and this would leave the mean temperature of the cylinder walls about 350 degrees. The fire test of a good lubricating oil should be at least 400 degrees F., so there is a reasonable margin of safety. The water-cooling system is not intended to keep the motor cold, merely cool enough to preserve effective lubrication, and any surplus oil is burnt off and passes out with the exhaust gases, becoming visible as white smoke on being discharged into the atmosphere. The expansion of pistons and cylinders due to friction is not taken into serious consideration, the pistons being machined small enough to allow for expansion due to the temperature during combustion, and the elasticity of the piston rings is sufficient to take care of anything short of overheating.

Carbon, which enters largely into the composition of oils, is separated by the action of the intense heat and is deposited on the walls of the combustion chamber, plugs, etc., therefore, using an excess of oil causes various forms of trouble. The carbon becoming incandescent, may fire a charge of gas prematurely, causing excessive strains on the piston, piston pin and crankshaft. The motor will also pound, giving a sound similar to that when the spark is advanced too far with the motor running slowly, and under a heavy load. The ignition plugs will be fouled or short-circuited and the motor is liable to overheat. Considering, finally, the length of time needed to make proper adjustments, and that of clearing the cylinders of the carbon deposits, there is no reason or excuse for having a car in every day use smoking like a locomotive. To insure sufficient oil reaching the cylinders, a groove is usually turned in the cylinder walls, at a point low enough to prevent oil being taken directly into the combustion chamber. Shallow oil grooves, turned in the piston, or a ring placed below the piston pin, pass this every stroke and carry up a certain amount of oil, depositing it on the cylinder walls, the upper rings then collecting and carrying it to the top of the cylinder.

## Poor Lubrication Affects the Compression.

The oil working into the minute irregularities between the piston rings, their grooves and the cylinder walls, has much to

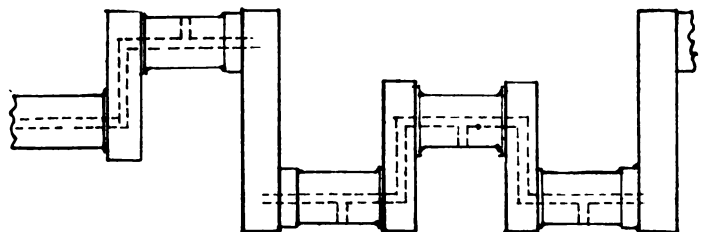

Fig. 2—Section of crankshaft for four-cylinder motor, having three main bearings, and showing method of drilling crankshaft to lubricate connecting rod and bearings.

do with the ability of the piston to hold compression, especially if the rings or cylinder are somewhat worn. This will be noticed by the driver who has given the cylinders a bath of kerosene to clean them. It will be found that the compression will leak out very much quicker than when the cylinders have plenty of oil. Some manufacturers using quantities of oil in the oil-pan have found it necessary to put baffle plates at the bottom



of the cylinders, leaving room for the movement of the connecting rod, and yet found that plenty of oil reached the cylinder walls. Without the baffle plate so much oil was taken into the combustion chamber that the motors constantly emitted a dense smoke, and were bothered a great deal with carbon deposits. The usual location of the camshaft is in the crankcase so that oil is splashed on it by the connecting rods. If placed there it never needs attention so far as oiling is concerned. Some designers place it in a separate compartment and fill this with oil or grease but this system has no particular advantage.

The connecting rod and crankshaft bearings must be provided with plenty of lubricating oil and it is common practice to use one grade of oil in the engines. There is a pressure on the piston and transmitted directly to the crank shaft, at the beginning of the power impulse, of between 10 and 18 atmospheres, depending on the amount of throttle opening, and the oil must have sufficient viscosity to maintain a film between the bearings and crank pins that will cushion the sudden force of the explosion. Here the expansion due to friction is very important and the design must provide for sufficient lubrication, also sufficient bearing surface so that the heat generated may be readily dissipated. If the bearings run hot, the crankshaft becoming heated must expand, likewise the bearings, and the two expanding uniformly in all directions, will grip each other much tighter, using much more power and either shaft or bearing will be badly cut. If the heat is increased to the danger point the bearings will be burnt and connecting rod or crankshaft is very liable to be broken.

#### How the Lubricant Reaches the Bearings.

Figs. 1 and 2 show two different methods of drilling the crankshaft to convey the oil to the crank pins, and it will be noticed that the oil holes discharge at the highest point of the revolution, corresponding to the position of the piston at the beginning of the power or firing stroke. The supply is received by the main bearings from the oil pump and the oil hole in the shaft, coinciding with that from the oiler has a little oil forced in each revolution, and generating centrifugal force throws it rapidly through the passages. The majority of modern motors are equipped with splash lubrication and have the connecting rods dip into the oil each revolution and splash it all over the inside of the crankcase. Some types are equipped with a scoop pointing in the direction of rotation, at the lower end of a passage connecting with the crankpin. The oil is sent into these passages with considerable force, owing to speed of rotation, thus assuring sufficient oil to the connecting rod bearings.

This is worked to the ends of the bearing and thrown off in the shape of a fine mist that penetrates to every part of the crankcase. The oil splashed onto the lower cylinder walls and not carried up by the piston is caught in little troughs, cast in the crankcase and drilled so that the oil runs down to the main bearings. In addition to the pipe from the oiler, the better designs provide an oil wick or an oil ring or chain, all types carrying oil from a shallow pocket corded in the bearing cap, the wick by capillary attraction and the ring or chain, revolving with the shaft, their lower ends immersed in the oil will carry up a considerable quantity that will spread over the shaft. This oil ring system is used very successfully in electrical machinery. With a splash lubrication it is advisable to drain the crankcase at frequent intervals, and put in a fresh supply of oil.

The modern ball-bearing gear box requires but little attention. Periodic filling with suitable lubricants is sufficient. On chain-driven cars the gears and differential are usually exposed by lifting one cover. On shaft-driven cars the differential and rear axle system requires a certain amount of attention, as too much oil in the differential is liable to leak through the axle sleeve and hub, usually getting on the brake drums. If this happens, the best thing to do is to jack the wheel up and squirt gasoline on the drum, slowly revolving it meanwhile. Manufacturers usually put a plug in the differential case showing the proper height at which to keep the oil level. The gear box

should be kept a little less than half full. If too much is put in, the oil will be thrown out of the shaft and bearing housings, but a little leakage does no harm as there is always dust present and the oil leaking will serve to fill the crevices and make the case dust tight. In regard to the wheels, universal joints, clutch, and many little places about the car, all need attention occasionally.

#### Care in Oiling Is a Prime Necessity.

The wheels should be cleaned and packed with grease once or twice a season. Universal joints at intervals necessarily shorter. Latest designs provide for their lubrication through the shaft from the gear box. Earlier types are best packed in grease and enclosed in a leather boot. On many shaft-driven cars, where the shaft runs through a sleeve, daily attention should be given. The lack of a few drops of oil may rob the car of 50 per cent. of its power. Multiple disc clutches use oil or an oil and kerosene mixture, and the tendency seems to be for the oil to gum. Their action when slipping or dragging is sufficient indication as to when they are in need of attention. Leather-faced clutches will work much better when cleaned with kerosene and given a dose of neatsfoot or castor oil. The oil should be spread over the surface of the leather by using a long knife blade, or by running the motor for a few moments with the clutch released. When treating the clutch leather this way it is

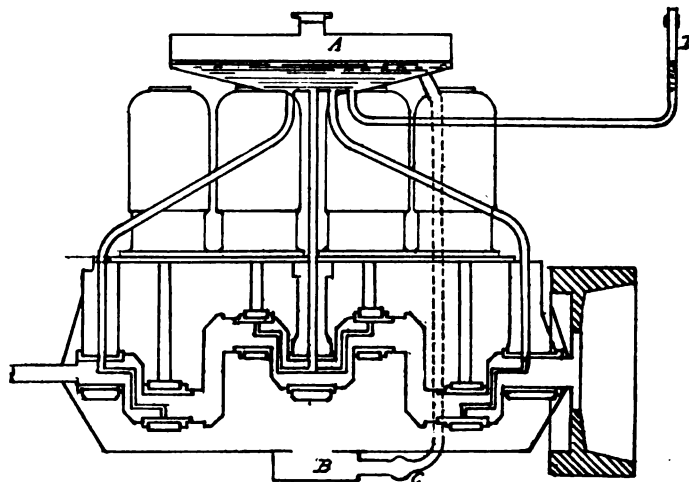

Fig. 3—Continuous circulation oiling system of Pierce Arrow. The oil flows from the crankshaft into the oil well B, and is pumped from there into the tank A, at the cylinder heads. It flows by gravity to the main bearings, and oilways drilled in the crankshaft to the connecting rod bearings. The oil pump, not shown, is at C. D is a glass showing height of oil in the reservoir.

better to let it stand over night if possible, and with the emergency brake lever, or a block of wood against the pedal hold the clutch disengaged. A hand oil can with a long spout is almost indispensable, and the starting crank, the steering pivots and connections and the spark and throttle connections, gear control and emergency brake levers, clutch and brake pedals, shafts and connections and the fan bearings will all work much quieter and sweeter for a few drops of oil regularly. It is the practice of drivers to fill the oil can from the cylinder oil supply and this practice is to be commended, as many lower grade oils contain acids strong enough to etch steel.

Here is a quick and simple method of oiling driving chains when touring, or in a hurry. Fill an oil gun with oil and direct the stream of oil out of its spout so it will fall on that section of the chain stretched between the top of the sprockets, and so the oil will reach each link. This is easily accomplished by varying the pressure on the piston of the oil gun. The links on the sprockets may be reached later and the oil on the free links will drip off and in falling will strike the lower section of the chain, thus lubricating its links. Driving chains when dry will make a disagreeable noise and often cause a jerky motion of the car that may be easily misunderstood as something serious.

The best method of lubricating chains is to clean them thoroughly in kerosene, then boil in a preparation of graphite and tallow that can be bought for this purpose. By this method, the grease is driven into all joints and will last longer, and by keeping the dirt out, will reduce the wear. After removing the chain from the lubricant the surplus should be removed with a cloth. The timer should be cleaned with kerosene or gasoline at regular intervals, and a little oil or thing grease put in. Graphite, which is not affected by temperatures of 2,000 degrees F., may be used to good advantage in many places, though it must be handled carefully, as there is danger of clogging the passages. It is very beneficial in the cylinders, filling the pores of the iron, and it preserves its lubricating qualities indefinitely. When using it the manufacturers' instructions should be followed closely.

**Various Methods Employed on Automobiles.**

The history of lubricating devices shows the use of many different types—individual oil cups with gravity feed, reservoirs with the oil flowing by gravity through sight feeds to the motor, some controlled by hand—and the operator's memory—others interconnected with the switch. Exhaust pressure has been used quite extensively in four-cylinder vertical motors, and crankcase pressure in the two-cylinder horizontal opposed type. Current practice now indicates a tendency among designers to use systems that may be trusted absolutely and to that end many of the better cars have force-feed oilers with either gear or flexible shaft drive. The steel spring belt and leather belt drives seem popular, but chains do not seem to be used very much. The latest system coming into general use is a continual circulation system. An oil level in a crankcase is maintained by means of holes drilled at a certain height, the extra oil flowing through these holes to an oil well.

It is drawn from here by an oil pump and forced to the cylinders or main bearings, and the unused oil dripping to the oil pan and from there to the oil well serves to keep up a continual circulation. Another design somewhat similar, pumps the oil to a tank near the cylinder heads, and it flows from there by gravity to the main bearings. These systems are very reliable and are usually provided with some means of ascertaining the amount of oil in the reservoir. The oil circulated practically similar to the water in the water-cooling system does not require the daily attention and filling of tanks that the other systems require. The oil gradually loses its lubricating qualities and after running some time it is advisable to drain the old oil off and put a fresh supply in. The makers' instructions will give necessary information in regard to the mileage on one filling. Splash lubrication is provided for on all but a very small percentage of American cars, without regard to the system used—whether force-feed or continual circulation. Many high-powered cars are fitted with a reserve oil tank holding from one to three gallons, and on some cars the tank and the method of raising the oil to the oiler could be greatly improved.

**American Cars Show Great Diversity of System.**

There are no fixed rules in laying out a lubrication system. One American car, with a motor developing nearly 60 horsepower, has two sight feeds, feeding the crankcase only and depending on splash lubrication altogether. Another high-grade car, rated 50 horsepower, has a gear-driven oiler on the dash with ten feeds, four to the cylinders, five to the main bearings and the tenth to the timing gears. The majority of cars seem to use from four to eight feeds. Fig. 4 shows a method of oiling the cylinders from one feed and distributor and insuring an even supply of oil to each cylinder. The same system may be applied successfully to the main bearings and the maze of pipes seen on some cars thus done away with. This method would not preserve the value of the pressure feed to each point, though the pressure from the pump would be present to the discharge point.

Designs have shown both extremes. One high-grade car ap-

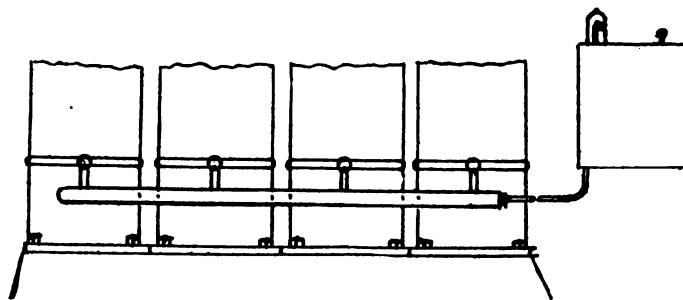

Fig. 4—Diagram showing distributor to oil cylinders. The oil pump forces the oil into the long tube, and from there it rises vertically an inch in order to insure equal pressure on the connections to each cylinder. Placing check valves at the top of this short vertical pipe would be good practice, but it is not absolutely necessary.

peared on the market with oil pipes, sight feeds, reservoirs, pumps, in short everything pertaining to the oiling system that could be placed on the dash was there, then other models have been brought out with only a button for stopping the motor by short circuiting the ignition current. It will be noticed that the majority of cars with an oiler on the dash show plainly the effects of the oil leaking, rotting the rubber mats and soiling anything and everything it comes in contact with. Modern oilers have been developed to such a stage that they may be almost absolutely relied upon, and there is no reasonable excuse for their presence on the dash. It is of interest to no one but the driver and he has plenty of opportunities to test or watch its working if placed in its proper place—under the hood. Compression grease cups are used to advantage on many cars with the camshaft, and rocker arms at the cylinder heads, but the grease cups employed have usually been of small sizes, either 3-4 or 1-2 inches in diameter. The smaller sizes in particular are very inconvenient to handle, as they are built with a flat head, and the edge knurled to allow the fingers to grip it. Were the manufacturers to design these plain types so that the head was slotted to allow the use of a screw driver, it would be quite a big improvement.

Conversation with the foreman of the assembling and repair department in a factory recently brought forth the following: "Most of the steering gears we have overhauled were in a condition that seemed to indicate that they had not received oil or grease since they were assembled in the factory. Lubrication is always provided for, a small plug or screw closing the oil hole. The steering gear (worm and sector casing) should be filled with grease at short intervals. Ball-and-socket joints on the steering connections will give best results if enclosed in leather boots, filled with grease."

**Detecting the Poorly Lubricated Motor.**

Oil leads should be cleaned out occasionally with gasoline, compressed air or steam, the latter being the best. A motor properly lubricated will not stop at once when the ignition is cut off. It should turn over several times, depending on the energy stored in the flywheel, and after the last complete revolution has ended the flywheel should swing backward and forward a few times before coming to rest. Were the cylinders taken off the pistons would be found on the same horizontal

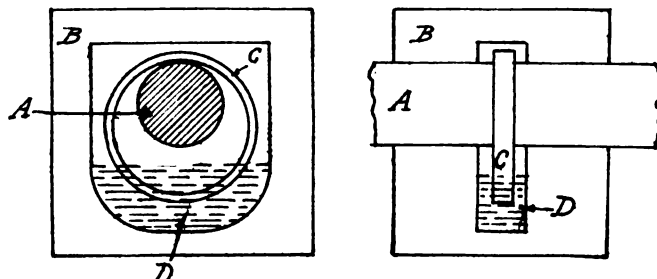

Fig. 5—Principle of oil ring. A, shaft; B, bearing; C, oil ring; D, oil. The oil chain is very similar, the flexible links conforming to the contour of the shaft for the upper half of its circumference.

plane (or very nearly so). If the motor stops quickly with a slight jerk, it is either very stiff or dry; stiff if the bearings have been taken up very recently. To get the best results the oilers should be adjusted so that when the motor is running at medium speeds, very faint traces of smoke should appear, vanishing at a distance of six to twelve inches from the end of the muffler discharge pipe. This adjustment will be readily found after a few trials. If in any doubt as to whether the motor is getting enough oil or not "open" the oil pumps so that more oil is fed. Better too much than too little always, and with modern systems it is hard to get an excessive amount for the reason that the speed of the oiler is in the proper proportion for the motor.

Many oils contain acids that will etch steels readily. The following is recommended as a test: Soak a piece of waste in the oil and wrap around a piece of polished steel, and place in the sun. If there are acids present the face of the steel will reveal their work in an interval of from a couple of days to a week, depending, of course, on the strength of the acids. This is another reason why only the best oils should be purchased, whether used in the cylinder or the oil can.

The manufacturer of your car has used plenty of oil in running the motors in, and the shop and road tests. He is constantly experimenting with new oils that are sent him by the refiners to be thoroughly tried before they are placed on the market as suitable to his motor. He issues an instruction book that contains explicit directions in regard to the amount of oil to be used, also information about oiling the wheels, transmission system, etc., in some cases going as far as to paste a copy of oiling instructions on the framework of the body where it must be seen every time that the gasoline tank is filled. This also recommends the use of well-known oils, all perfectly adapted to the places they are intended to lubricate. When touring carry a spare gallon along with you, and if you should run short and cannot get your usual grades, insist on being furnished with a standard make of oil as near like your regular grades as possible. Buy the best you can get. You may save a few cents per gallon by using a cheaper grade of oil, but it would take the savings on a great many gallons to cover the expense of having your cylinders rebored and pistons or rings replaced.

## AN INSTANCE OF ACCURACY REQUIRED IN CONSTRUCTION

By J. T. GRIMSHAW.

It is only those who are engaged in the most important positions in an automobile factory who understand and appreciate the mechanical refinements necessary to the production of duplicate parts. The proverbial hair's breadth is no fit simile for

as to hold sixteen  $\frac{5}{16}$ -inch steel balls with  $\frac{3}{32}$ -inch to spare for clearance; that is  $\frac{3}{32}$ -inch divided by sixteen (the number of the balls) equals about  $\frac{1}{10,000}$  in an inch clearance for each ball, permitting its free running in the race.

Fig. 3 shows an indicator with the front plate or guard left off. It consists of two  $\frac{5}{16}$ -inch steel balls, same as used in the bearings fitted and soldered with soft solder (so as not to draw temper from the balls) to two sheet metal pieces, one of which is fixed rigidly to the back or main plate; the other is hinged onto a taper pin screwed into the same plate with a jam nut in the back. The pointer of the indicator is hinged in the same manner, the movement of the pointer on the graduated scale being approximately 63 times as great as any existing error in the ball races.

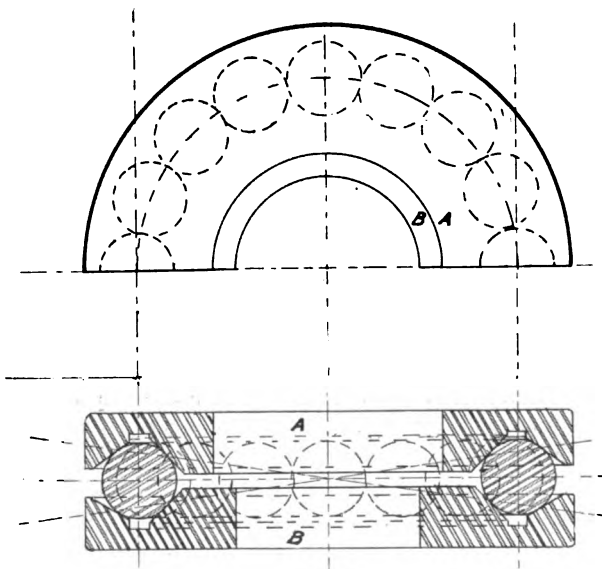

Figs. 1 and 2—Section and plan views of ball thrust bearing.

the accuracy commonly required. The average diameter of a hair from a human head is about one and three-quarter thousandths of an inch, and there are a multitude of automobile parts which if finished that much too small would be consigned to the scrap heap, or if that much too large, would have to be gone over again and brought to size.

Below are shown drawings of a device used in a large automobile factory for the production of absolutely duplicate ball thrust bearing races. Fig. 1 is a section, and Fig. 2 is a plan view of one-half of a ball thrust bearing. In such bearings it is absolutely necessary that the ball races be as near alike as mechanical skill and ingenuity can make them. That is to say, suppose the discs *A* and *B* were laid separately with their races uppermost and a set of balls placed in each, the distance from the center of any ball to the center of the ball diametrically opposite to it must be the same in *A* as in *B*, as shown in Fig. 1. The discs are tool steel hardened and ground to size, and the size of the races such

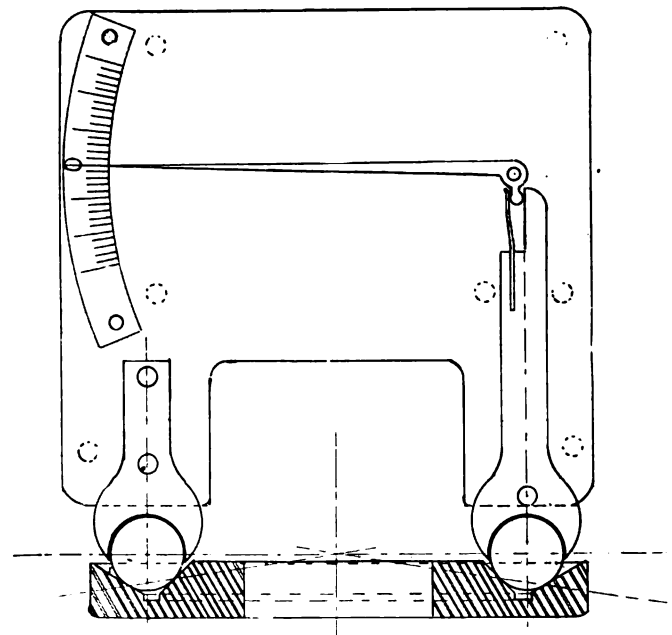

Fig. 3—Instrument for detecting errors in ball races.

It will be seen, therefore, that these races will be remarkably accurate, when it is remembered that the operator is allowed no leeway, but must finish exactly to size with the indicator at zero, representing almost mechanical perfection, and this is only one of the many instances where the same accuracy is required.

## LETTERS INTERESTING AND INSTRUCTIVE

### WHAT IS BAD PRACTICE ON THESE TWO POINTS?

Editor THE AUTOMOBILE:

[1,406.]—There seems to be a diversity of opinion among intelligent autoists as to the advisability of the use of graphite in the crankcase. Some advise mixing a teaspoonful of flake graphite with every quart of cylinder oil put into the crankcase for the purpose of lubricating the cylinders, saying it will give a fine surface to the inside of the cylinders if so used. Others say it is a very bad practice, as it will cause the pistons to bind. (See Automobile Catechism, Sec. 189.)

Again, in case the chain breaks on a chain-driven car, the "Automobile Catechism" says: "Fasten the sprocket at the end of the countershaft from which the chain is gone. The car then can be driven home by the other chain. (See Catechism, Sec. 274.) To this some say it is bad practice; better draw your car home, as the strain on the differential gears is too severe.

Meriden, Conn.

GEORGE A. FAY.

We understand that graphite is very successfully employed as a lubricant on the automobile and tests have shown it to be highly effective for some of the numerous special conditions to be found on the power-driven vehicle, but, like everything else, this is something about which many of the experts and "near experts" hold entirely opposite opinions. The experience of a few autoists who have used it in this manner should go further toward settling the matter than a great deal of theory, and we invite those who had occasion to use this lubricant to give their opinions as to its value for the purpose.

Driving the car by a single chain naturally imposes a very severe strain on the differential, but if properly carried out there is no reason why it cannot be done without causing any injury to the car, particularly where a long tow home is the only alternative. Flood the differential with oil before attempting to subject it to the extra strain and drive slowly. A little care will avoid any chance of injury as well as the tow. Where some distance is to be covered it would be well to examine the differential from time to time and keep the supply of oil replenished, as this will save it.

### GEAR RATIO FOR A LIGHT FRICTION DRIVE.

Editor THE AUTOMOBILE:

[1,407.]—I am rebuilding a small automobile which will be driven by a "one-lunger," 3 1/2 bore and 3 1/4 stroke, making from fourteen to eighteen hundred r.p.m. Transmission is to be through a friction drive by a single chain to the periphery of the differential. The friction disc and driven wheel of the transmission are each twelve inches, and the wheels of the car are twenty-six inches.

Will you kindly advise me what size sprocket to use on the jack shaft, and also on the differential. I find your department "Letters Interesting and Instructive" of great assistance to me.  
New York City.

J. HALLOCK WARING.

As your motor will naturally have to run very fast when developing its normal power, and as the friction driving gear you mention permits of the driven wheel being revolved at a very high speed, it will be necessary to use an extremely low gear ratio. For instance, with sprockets of the same size on both countershaft and differential, the latter would be turning at the rate of 1,800 r.p.m. when the motor was running at the same speed, assuming that the percentage of slip in the friction gear is practically negligible at this high speed. As a 26-inch wheel covers 6.8 feet per revolution, this would mean a speed of better than two miles per minute, again assuming the motor and transmission to be capable of driving the car at that rate. We should advise making the forward sprocket either 5 or 6 tooth and the rear sprocket 36 tooth, making a reduction of 6 to 1 in the latter case or 7.2 to 1 in the former. This would give the car a maximum speed of slightly over twenty miles per hour with the 6 to 1 gear and about eighteen miles an hour with the lower gear; the motor will probably not be capable of more.

### ELIMINATING THE NECESSITY FOR POLISHING.

Editor THE AUTOMOBILE:

[1,408.]—Kindly advise me through "Letters Interesting and Instructive" if there is some substance known to coat brass on a car, so you won't have to polish it.

I have a 1908 four-cylinder Model 10 Buick. Would a magneto give satisfaction on such a car, do you think?

Gordon, Neb.

L. H. JORDON.

An attractive green finish may be given the lamps by the use of a solution of acetate of copper, or carbonate of copper, or by using a mixture of the two, according to the tint desired. The chemicals, familiarly known as "verdigris," are mixed with a light varnish and applied with a brush. While still wet the high parts are wiped off with a rag dipped in the solvent of the varnish, which will probably be found to be alcohol. After the process of applying this color has been finished, it must be allowed to dry hard and then a coat or two of transparent lacquer is put on for protection. This will give a finish that does not require any polishing as long as it lasts, which will depend upon the amount of rubbing the lamp is given to remove mud, etc., as well as the weather. There are a great many variations of the process described, but none of them are absolutely permanent where subjected to the weather. To obtain a permanent finish for such conditions electro-plating is required.

### LENGTHENED WHEELBASE IS AN IMPROVEMENT.

Editor THE AUTOMOBILE:

[1,409.]—In letter No. 1,383, a writer inquires about a Darracq car with a lengthened wheelbase. I have used a car of the same make and possibly the same model for three years. After getting thoroughly tired of using a car when the rear wheels carry the entire passenger load, I lengthened the body 10 inches, and the wheelbase 18 inches, and changed it to side entrance. It is not yet completed, but it is a sure improvement.

Wakefield, Mass.

E. I. PURRINGTON.

As stated in the answer to the letter referred to above, the short wheelbase was one of the most radical defects in the designs of cars that appeared prior to 1904. The car with a very short wheelbase is almost unmanageable above a certain speed, and does not steer well at speeds as low as twenty-five miles an hour, while it has a most disconcerting habit of "spinning" around on the road when the brakes are applied suddenly while moving at a good rate of speed. The way some of the old cars would "cavort" under such circumstances, particularly if the road happened to be at all slippery, was enough to make the driver's and passengers' hair stand on end, and doubtless such conditions often led to the car's overturning. Apart from the extra comfort of the side entrance tonneau, lengthening the wheelbase is an improvement that is highly appreciated by anyone who has had experience in handling a short car.

### SOME INTERESTING FIGURES FROM ABROAD.

Editor THE AUTOMOBILE:

[1,410.]—"Another Illusion Gone" is the heading of an article in a well-known motor trade paper, and refers to the fact that the French, the pioneers of the pleasure motor car, are, from a motor manufacturer's point of view, in a very bad way, with their exports rapidly declining, and their faults too long glossed over by their early reputation now exposed to public view, with the result that most French cars have fallen in reputation and orders.

The reasons for the collapse of French motor cars are various, but may be set under the following headings:

1. Lack of knowledge of foreign trade requirements, and inattention to customers' complaints and orders.
2. French manufacturers under-estimated the strength of the motor movement in countries other than France.

They believed themselves the leaders, whereas statistics recently published show that Great Britain has the greatest number of motor cars in use, viz., 79,000. Germany over 36,000, and France only



about 34,000; as a matter of fact, if the world was taken, I find France would only be fourth and not third, as America has certainly nearly as many in use as Great Britain, if not more, so that France, from being the pioneer in the manufacture and use of motor cars, has now fallen into the fourth position, and Great Britain as a user of motor cars has left France far behind.

The net result of this is that French manufacturers have much fewer orders than usual this year, and as far as I can find from inquiries there are only one or two French firms that have increased their British business at all, and probably the reason why one of them, namely, De Dions, has done so is because the manufacturers of the De Dion cars have had the advantage of an English company to advise them, and considering the multitude of their orders, British advice was apparently worth following. On the other hand we see some British firms, even in this year of financial crisis, increasing their business and actually selling more cars than ever before.

In powerful motor cars the British six-cylinder principle initiated by Mr. Napier shows a progress this year greater than ever before.

The number of six-cylinder cars sold since October 1, 1907, to April 20, 1908, being 37.6 per cent. greater than last year, and the orders still in hand to be executed within the next two or three months show 98.3 per cent. in advance of the same period last year.

The whole matter interests me greatly because at a dinner held on February 28, 1906, I set out clearly that the French motor car trade was on the decline; since then it has looked better than it really is, by reason of the imports to this country of French motor buses and motor cabs, but the next six months will see such a falling off as will once and for all establish the fact that British cars are best to sell to motor car users in this country.

London, Eng.

S. F. EDGE.

While Mr. Edge's observations are doubtless the result of personal experience in sizing up the situation in the far-seeing manner for which he is noted and are of considerable interest as showing the view taken of the British market for Continental machines by one who should be in a pretty good position to know, his figures are rather misleading, at least where the number of cars in use on this side of the water are concerned. As an instance of this, it may be cited that the registration figures for the State of New York alone—but one of the almost fifty States in the Union—are now close to 53,000, and as these figures have advanced more than 20,000 in the past two years it is safe to say that 30,000 would be a conservative estimate of the number of cars in use in this State. Probably the figures published in *The Car* recently, in which the United States are credited with 130,000 cars in use, are more nearly correct and will be found to err in being too conservative if at all.

#### WHAT IS THE CAUSE OF THIS MYSTERY?

Editor THE AUTOMOBILE:

[1,411.]—Will you kindly suggest through "Letters Interesting and Instructive" the probable cause of the following trouble with my Maxwell two-cylinder touring car? Ignition good, batteries show 14 amperes, mixture seems good, engine starts on first compression and runs all right for about an hour, then seems to get pretty warm, but radiator water does not boil. Suddenly engine slows down and stops. Has to be cranked several times before it will start again, then goes on without further trouble. Always does this after being run about an hour. Carbureter thoroughly cleaned, also gasoline strained. Circulation pipes to radiator were found somewhat reduced by deposit, which probably caused heating, but why should engine stop from this cause? There is no seizure, as engine cranks readily.

Hendersonville, N. C.

W. S. OSBORNE.

Just why the motor should stop at the end of an hour, or any other definite period, and then resume and run continuously thereafter without any trouble, is as much of a mystery to us as it is to you. A motor will frequently come to an unexpected stop after running a short time and cranking will immediately restart it, but this is often due to a temporary failure of the fuel supply that the short stop permits to right itself. Under the circumstances we would only be hazarding a guess at what the probable cause of your trouble may be and we think there are a great many of our subscribers who find themselves in a position to do something more definite than this, so we will put it to them to answer.

#### QUERIES ABOUT STEEL AND LUBRICATING OIL.

Editor THE AUTOMOBILE:

[1,412.]—What kind of steel should be used for the pin in a steering knuckle of the Elliott type? Does a colorless oil contain less carbonize than a dark oil?

A SUBSCRIBER.

Aurora, Neb.

The best steel procurable is none too good for any part of a steering gear. Better write the makers for a replacement part, rather than use ordinary material for making it, unless you have facilities not enjoyed by the average autoist, in which case it is advisable to employ either a good alloy steel, showing high tensile strength and yield point, or a good quality of low carbon steel, in case the alloy steel is not procurable. Tool steel should serve the purpose well. A colorless oil is said to possess this characteristic, but we have never had any personal experience of the kind.

#### REVERSING POLARITY OF A STORAGE BATTERY.

Editor THE AUTOMOBILE:

[1,413.]—What effect or damage would occur if in charging a 6 volt 60 ampere storage battery the wiring should be reversed, that is, the positive wire of the charging set be placed on the negative binding post of the battery and the negative wire of the charging set to the positive binding post of the battery? If any damage should result, how would you remedy it?

J. S. KARNEY.

Clinton, Ind.

The formation of the plates would be changed from one chemical composition to another by the charge, and usually the battery would be ruined. We think the most advisable thing for the average autoist to do would be to return the cells to the maker with a statement of what has been done. At least, it is our opinion that this would be the most economical and effective way of remedying the trouble.

#### ABOUT THE ONE-CAR 24-HOUR RECORD.

Editor THE AUTOMOBILE:

[1,414.]—Please inform me what the world's record for 24 hours' continuous running on a one-mile track by one car is. I have seen two claims, the National, 1,094 3-16 miles, and the Renault, 1,079 miles. Did Edge use more than one Napier in his 1,581-mile record on Brooklands?

Milwaukee, Wis.

INQUISITIVE.

We believe that the record of the National still holds good for a 24-hour event on a one-mile track, using the same car driven by one man. Edge only used one car in making his record at Brooklands, but two or three other cars of the same make raced with him for the entire period.

#### ANOTHER GOOD WAY TO PREVENT TAMPERING.

Editor THE AUTOMOBILE:

[1,415.]—In a recent issue of your paper, I noted an article regarding the locking of a car by locking the clutch-pedal in such a position as to disengage the clutch. I find the following a very effective way of preventing my 1907 Stoddard-Dayton being used without my permission. I cut an electric snap-switch in on the ground wire to the commutator and fasten the switch to the dashboard under the hood. Then by simply turning off the switch, putting down the hood, and fastening it, and locking a padlock through the fasteners, one on each side, the car is effectually locked, and yet it can be moved around the garage, as is sometimes necessary. My car was used for an all-night "joy ride" last summer while I was stopping in your city. Hence the above scheme to prevent a repetition.

C. A. COCHRAN.

Youngstown, O.

#### ABRASIVES ARE VERY DIFFICULT TO REMOVE.

Editor THE AUTOMOBILE:

[1,416.]—Referring to letter No. 1,387 by E. Sparenberg, would like to say that I can see ruin ahead for V. R. Lane's motor if he adopts the practice of introducing emery in any form into his cylinders. I also much doubt the ability of any man to grind cylinders as proposed and get them round and true. I would advise Mr. Lane to send his cylinders to a cylinder-grinding machine regardless of the expense, as he would then have something he would enjoy. As it is almost an utter impossibility to completely clean out a cylinder of emery flour or dust, he will find that the grinding will continue long after he puts the motor to work.

Providence, R. I.

W. J. B. S.

## THOMAS '09 "LITTLE SIX" HAS GOOD FEATURES

DEVELOPMENTS of an unusual nature have been confidently looked forward to in the policies of many of the large makers for 1909, but it was hardly thought that they would materialize so soon, or that they would be of such a revolu-

tionary nature as the announcement of the Chalmers New Detroit four-cylinder car to sell at \$1,500, and the Thomas "Little Six" for 1909, listing at \$2,500. These figures alone fail to convey the impression that is made when the technical details of the car are reviewed, for then it is realized for the first time that these offerings are not merely repetitions of attempts that have gone before to produce a cheap car, but are the successful culmination of long study in the problem of producing a high-grade car to sell at a low price.

This will be at once apparent from a description of the features of the motor. The cylinders are cast in triple block with detachable water-jacket heads and end plates. Both the inlet and exhaust ports give into common passages, so that only double branch pipes are necessary from the carbureter and exhaust outlet. All the valves are on one side of the engine, and the valve lifters are made with flat ends, which bear against the cams in place of having roller contacts, as is usual. Both camshaft and crankshaft are supported on annular ball-bearings of a positively separated type. The crankcase is a tubular construction and is

not made in the conventional upper and lower halves—with end plates for taking the end bearings of the crankshaft and camshaft. It is carried on a three-point support, the forward end of the crankcase having a central foot which reposes on a drop cross member of the frame, whereas the rear of the engine is supported on a transverse tube which passes through split eye-holes on the rear of the crankcase and is supported on side frame members. This tube also serves as an attachment for the steering column housing. No fan is used behind the radiator, substitution for it taking the form of fan-blades riveted to a sheet metal band attached to the periphery of the flywheel.

The connecting rods are of especially light pattern, and have the big ends lined with Parson's white brass. The water circulation is by thermo-syphon, and, in order to provide for sufficient circulation, the pipes which conduct the water to and from the radiator are of exceptionally large section. This can be seen by inspection of the photographs of the engine, reproduced herewith, an interesting feature being the attachment of the lower water pipe to pockets which form extensions from the cylinder jacket walls. The radiator is similar to that used on the Thomas-Detroit, having horizontal cooling vanes closely spaced. A very interesting feature of the cooling system is the means whereby its water capacity is increased to the limit demanded by the use of the thermo-syphon circulation system in vogue.

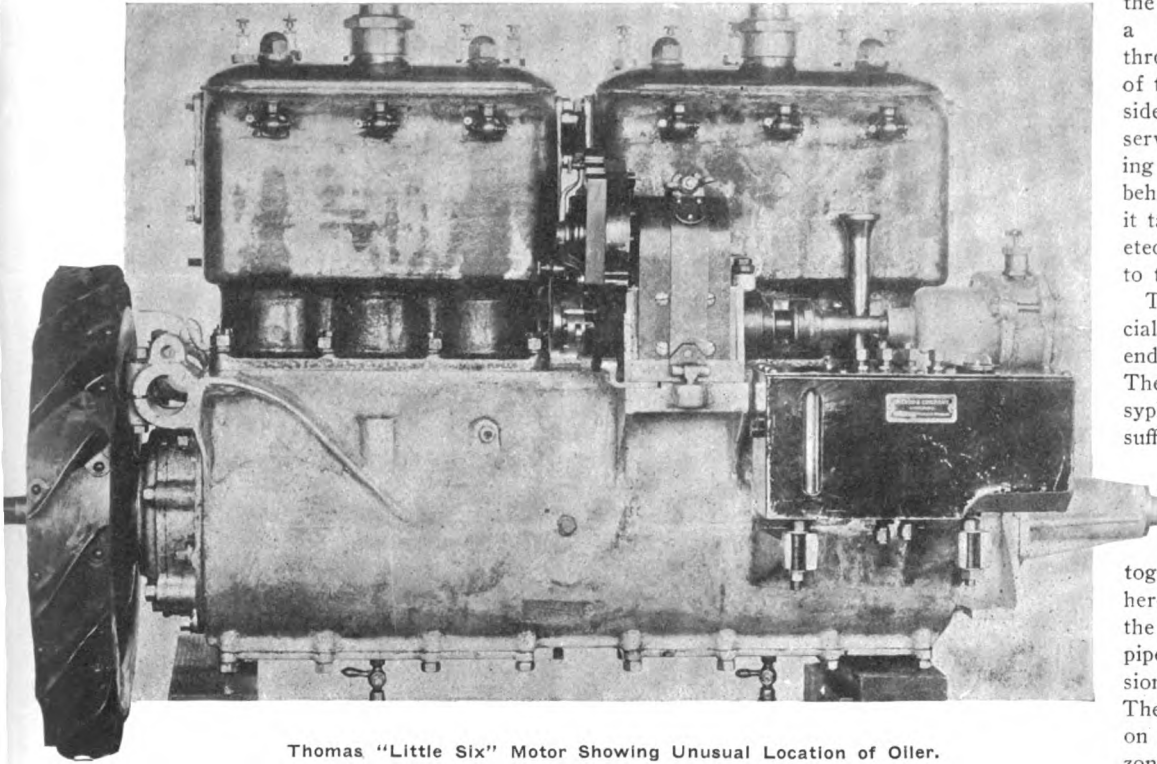

Thomas "Little Six" Motor Showing Unusual Location of Oiler.

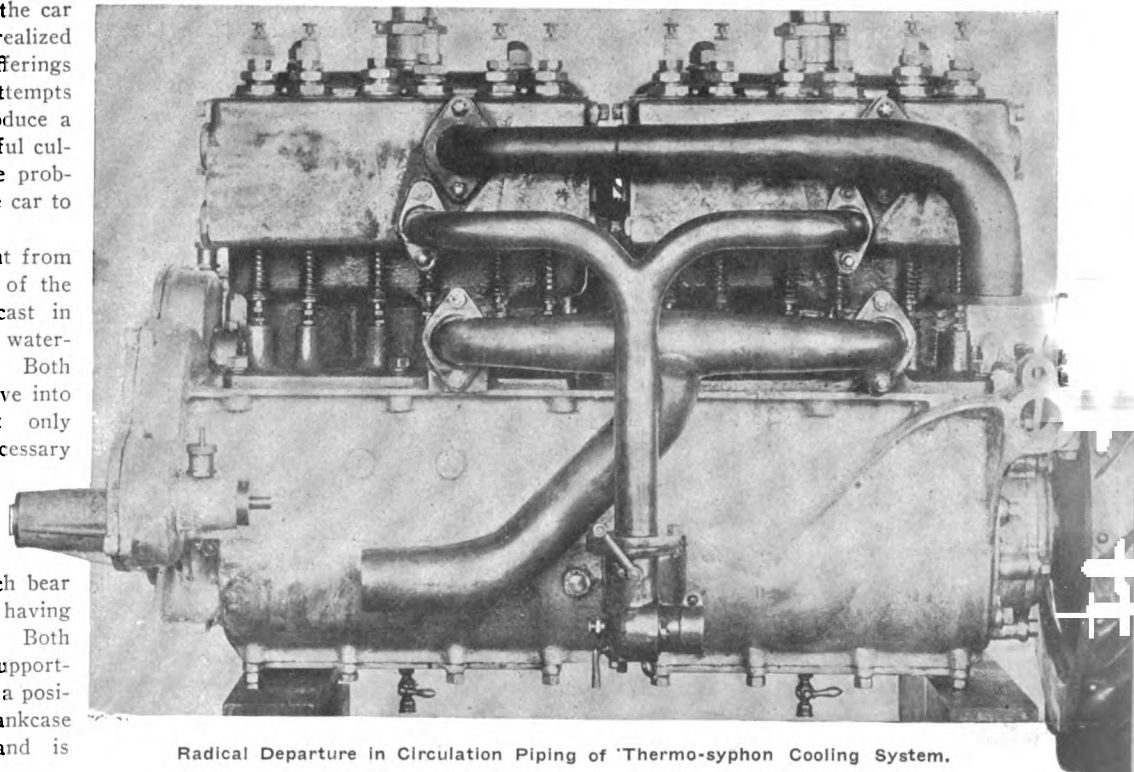

Radical Departure in Circulation Piping of Thermo-syphon Cooling System.

Double ignition is provided, the distributor being located on the carbureter side of the engine, while the high tension magneto, by Bosch, secured in place by an encircling metal strap, driven through the medium of an Oldham coupling, is upon the right-hand side of the motor. The lubricator, which is a

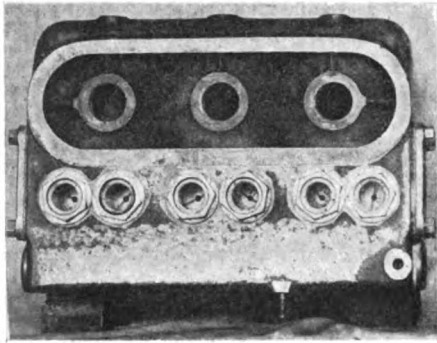

Plan View of Three-cylinder Casting.

force feed of McCord pattern, is located on a level with the magneto base, also on the right-hand side of the engine, and is driven positively through the means of a pair of spiral gears. Sight feeds are located on the dash so that the lubrication can be constantly watched by the driver. The lubricator can be removed easily by an ingenious way of slotting the lugs which support it. Three point support for the engine is utilized, the rear end of the motor being carried from a cross tube support by brackets bolted into the side rails of the frame while the front end of the motor rests upon the drop bar, forming the front cross member of the frame. An unusual refinement is the carrying of the starting crank and its disengaging mechanism integral with the crankcase. The high tension leads from the distributor and magneto, are neatly cased in housings supported by small brackets located on the water jacket covers. These housings are so arranged that only the smallest possible amount of wire is exposed between the housing and the plugs, this making both for neatness and electrical efficiency.

A steel band having helical blades riveted to it, encircles the flywheel, and this insures a very efficient fan action without decreasing the strength of the flywheel. The clutch is of the three disc pattern used on all previous Thomas models, though it has been somewhat lightened and refined to suit this new model.

Directly behind the clutch is a well designed universal joint, this joint being the only one used in the transmission system, while back of this joint is the clutch collar, mounted with a ball thrust bearing. The clutchbrake pedals and the selective portion of the gear-striking mechanism is all carried in brackets mounted on the central cross member of the frame, the propeller shaft housing also being suspended from this same cross member. The transmission is grouped about the

rear axle, is of the selective type, and gives three speeds forward and reverse. The transmission and rear axle form a neat unit. The shafts are carried on annular ball bearings, the gears being made from a special heat-treated nickel steel. A single universal joint is used, that forward of the clutch collar, but the construction is such that the propeller shaft is exceptionally long, providing for ample road clearance and a small transmission deflection. The housing of the propeller shaft is utilized to transmit both driving effort and torque.

The frame, which is of the single drop pattern, is suspended on long semi-elliptical springs at the front end and full elliptical with double scrolls at the rear. This gives an easy action with very little recoil. All the brake connections lie within the lines of the frame, so that the utmost cleanliness in contour is secured for the outline of the completed car, together with exceptional ease of keeping the machine clean in bad weather.

The control is entirely standard. The change speed and brake levers are in the usual position, but particular pains have been taken to locate them with regard to the steering wheel, the pedals and the driver's seat, so as to secure the maximum of comfort. An unusual feature of the car is the fact that it is mounted on 36-inch wheels, 3 1-2-inch tires being provided for both front and rear wheels. In the body work the straight-line effect is carried all through.

Especially happy has been the proportioning of the body dimensions and the location of the driver's seat in regard to the control levers, the steering wheel and the pedal position. Luxury is provided by the use of very deep cushions and ample room in the passenger accommodation. The first aim of the Thomas designers has very evidently been to secure a combination of grace with comfort, for particular attention has been paid to the spring suspension. The wheelbase is 122 inches, sufficiently long to permit both the adherence to accepted lines and the provisions of well-balanced body work, and the engine—30-horsepower—should be ample to handle the car, primarily designed for comfort and general use, with ease under all conditions.

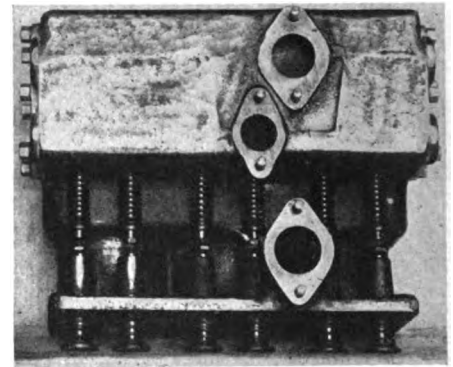

Valve Side of a Cylinder Casting.

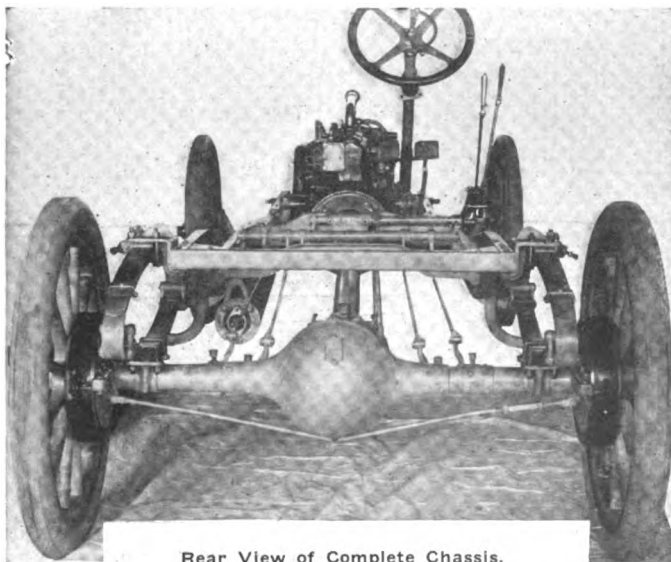

Rear View of Complete Chassis.

#### PANHARD EXPERIMENTS WITH NOVEL DEVICE.

Daily newspaper reports to the effect that the Panhard & Levassor Company has succeeded in perfecting a simple device to eliminate the change-speed gear box have been given considerable publicity within the past few days, but the statement of the case given by the New York representative of the company does not put as roseate a hue on the report as the dailies have given it. When appealed to for information Mr. Massenet said:

"As you are probably aware, the Panhard company is always on the lookout for improvement and is willing to try anything that appear to have sufficient merit, with a view to acquiring the patent should the claims prove sound. Whether this is some outside patent, or something developed in the shop, I do not know, but my latest advices inform me that some experimenting has been done with a device of this kind and the experiments are still going on. Whether the device will ultimately be applied to stock cars, I do not know, but if so it will probably only be to cars of very low power, if at all. Too much credence must not be placed in daily newspaper reports of such things, as they are written by non-technical men.



**I**F such a car as the Chalmers New Detroit, which is to be one of the E. R. Thomas Detroit Company's offerings for 1909, had been placed on the market three years ago, it would have been shunned by the novice and the experienced alike, and there would have been much head-shaking as to what it was built of to sell at the phenomenal price which its makers have put on this most attractive looking 24-horsepower, four-cylinder car, namely \$1,500. But under present conditions the latter is merely another striking indication of what a modern factory and purchasing organization can do with a good design to work on. It is likewise a sign of the fact that American makers are finally beginning to realize in no uncertain manner just where the popular demand is trending. There has been entirely too great a gap between the actually low-priced car with its numerous limitations of heavy weight and low power, and the medium-priced car with sufficient power and style about it to satisfy the man who realizes only too well what he wants in the shape of an automobile, but to whom the really good car has been an impossibility heretofore.

The Chalmers New Detroit strikes at a point between these two, where it is going to make its influence felt in no uncertain manner. As its makers state, it is a car in a class entirely apart from any of the low-priced machines hitherto placed on the American market, its designer, H. E. Coffin, having embodied in it features only to be found on machines, of either American or foreign origin, at many times its price. Some of these, briefly summed up, are the unit power-plant with its one-piece casting, multiple-disc clutch, selective type of sliding gear giving three forward speeds, full-floating type of rear axle, ball bearings throughout the car, and a number of others, which are mentioned further on.

Doubtless the feature that will earn the greatest commendation for the designer of the car is its extremely compact and well thought out unit power-plant. The four-cylinder, 24-horsepower motor, clutch and change speed gear-set are all inclosed in a single aluminum casing, which is constantly flooded with oil. The gear-

set case and clutch are attached directly to the flywheel casing and do not depend for their alignment on any part attached to the frame of the car, thus not only eliminating entirely the numerous troubles due to lack of alignment, but also providing the most effective protection possible for these essentials. The entire power-plant may be removed as it stands simply by taking out but six bolts.

The most striking feature to be found on a car that is being offered at such a price is the use of annular ball bearings of liberal size throughout. These are of the nonadjustable type, and are in every way duplicates of those being used on cars selling for many times as much. Even the crankshaft, which is unusually short and strong, owing to the one-piece cylinder casting, is carried on annular ball bearings—a construction only to be found in the highest-priced cars. The connecting-rod bearings are of die-cast tin babbitt, and have been designed with an exceptionally liberal amount of bearing surface.

There are numerous points of merit about the motor itself which will immediately attract the attention of the experienced eye. Lightness and compactness have been gained to an unusual extent by combining the four cylinders in a single casting, while

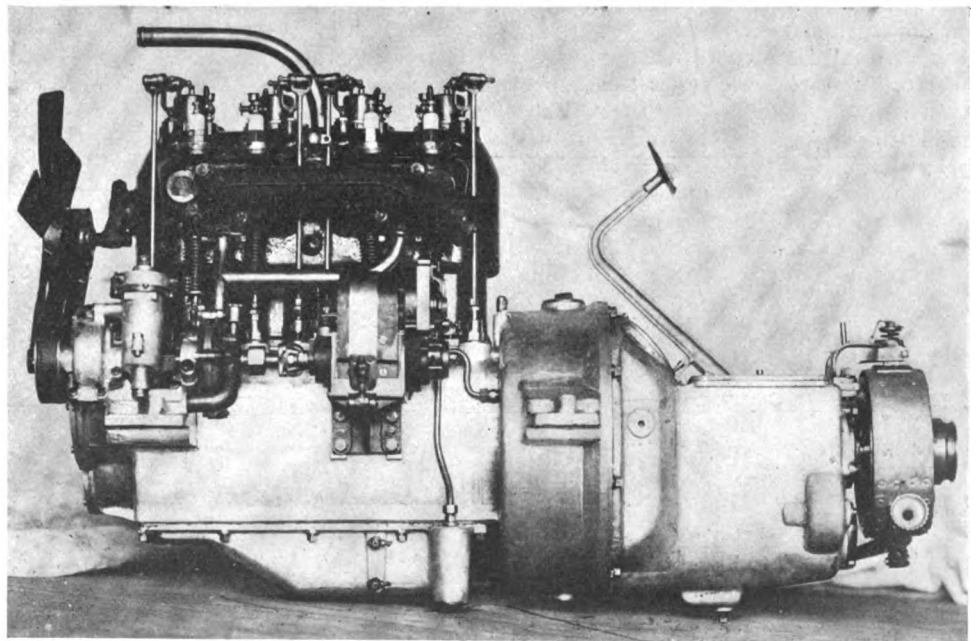

Compact Unit Power Plant and Gear-set of Chalmers New Detroit.



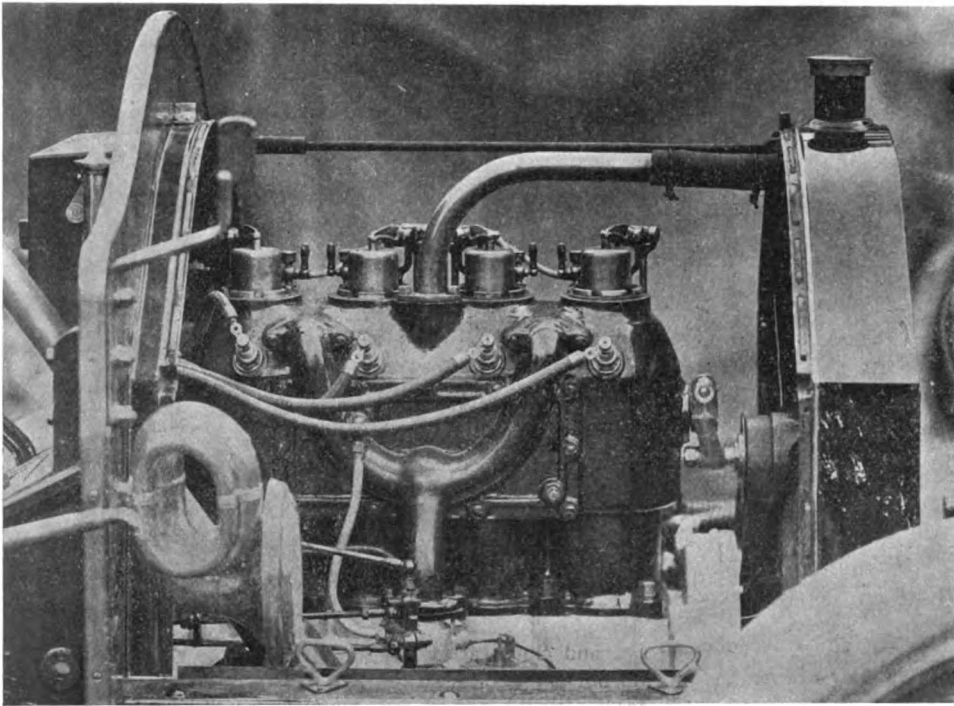

Carburetor Side Illustrating Neatness of One-piece Casting.

it also gives the further advantage of more satisfactory water-jacketing. The intake valves are placed in the head of the cylinder, and the exhaust valves are at the side, this arrangement making it possible to use very large valves, considering the bore of the cylinder. The intake valves are operated by overhead rocker arms, and measure 2 1-4 inches in diameter, while the exhaust measures 1 1-2 inches, and its operation is by means of the usual direct thrust method. Simplicity has been attained by employing the constant level splash oiling system originated by Mr. Coffin, fresh oil being continually supplied to the engine by a gear-driven pump, drawing oil from a reservoir at the bottom of the crankcase. Individual compartments are provided for each crank throw, and partitions have been placed in the crankcase, thus preserving the oil level throughout the crankcase regardless of the grade on which the car is traveling. With this system, a single filling of the reservoir is ample for a 500-mile run, while it requires very little attention and has an extremely high factor of reliability, owing to its simplicity and lack of small parts and tubes.

A vertical tube McCord radiator forms the chief essential of the cooling system, the water being circulated by means of a centrifugal pump located at the rear end of the camshaft and inside the flywheel casing. A feature that is indicative of the painstaking attention to detail which has been lavished on the car is to be seen in the radiator support. This takes the shape of a trunnion, thus relieving the radiator of all torsional strains set up by the twisting of the side members of the frame. An-

other feature that must be put down as an eye-opener, when the price of the car is considered, is the provision of a dual system of high-tension ignition, employing a Bosch magneto for the running side, and a coil and accumulator unit for emergency and starting. The same design of carbureter is employed as has become familiar on the Thomas Forty in the past, while an improvement has been introduced in the design of the gas-intake. Instead of the usual pipe leading from the carbureter, passages have been cast in the water-jacket cover of the cylinders, the charge thus flowing through a water-jacket passage on its course to the intake valves, thus avoiding condensation in cold weather.

The use of a selective type of sliding change speed-gear is another distinctive feature worthy of note. The gears slide upon a round shaft with four keys set at equal distances round it, engaging in corresponding keyways on the gears. All shafts and pinions are thoroughly heat-treated. The prop-

eller shaft is of heat-treated nickel steel, and runs through a long sleeve attached rigidly to the differential housing of the rear axle. This sleeve is fitted with annular ball bearings at its forward end, and takes both the driving and braking strain. It does away with the usual torsion rod and insures proper alignment of the rear axle at all times. A single universal is used just behind the gear-set. The rear axle driving unit is of the full-floating type, the entire weight of the car being carried upon the heavy axle tube. The live axles and gears are 3 1-2 per cent. nickel steel, heat-treated.

The suspension consists of semi-elliptic springs forward and three-quarter elliptics in the rear, the spring seats being swiveled spherically upon the axle tubing, thus preventing twisting of the spring under unusual shocks. Ball bearings are used throughout the differential and in the rear wheels. The front axle is a single piece drop-forging of new design I-beam section, the spring seats being forged integral with the axle. The center of the front axle is the lowest part of the car, and allows a full 9 1-2 inches clearance. The Thomas Forty will also be continued practically without change for 1909, with the exception of three-quarter elliptic rear springs, and will be known as the Chalmers Detroit Forty.

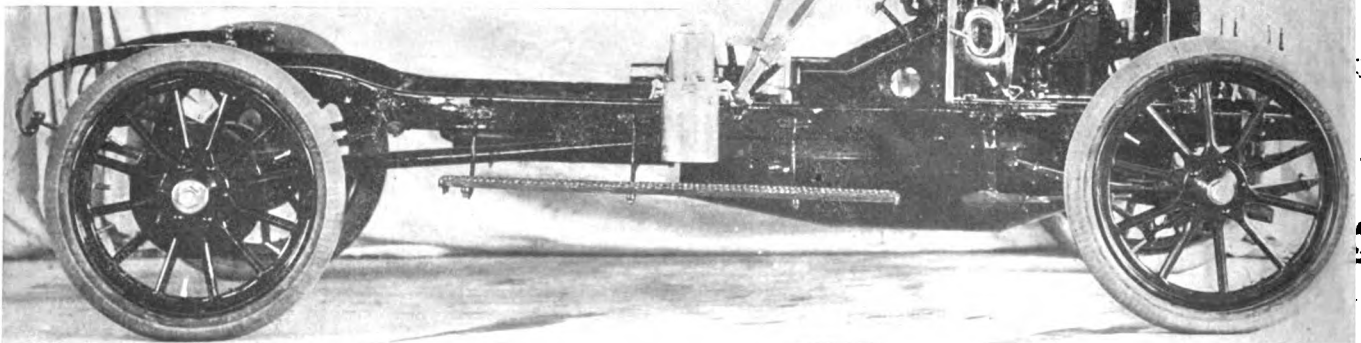

Side View Complete Chassis Which Gives an Idea of Small Space Occupied by Power Plant.

## AUTOMOBILE FIRE FIGHTERS FOR EAST AND WEST

ALL that is modern and progressive is usually ascribed to the large cities, and the rural visitor is usually shown the sights and wonders with great pride by his city cousin, but since the advent of the automobile fire engine, many small towns are taking the lead of their larger brothers by going ahead in this direction and installing apparatus for fire protection that is far more modern than that to be found in many a large city. An instance

1,000 feet of standard water hose, water-play nozzles, hand extinguishers, lanterns, pikes, hooks, crowbars, axes, door openers, ladders and the like, thus giving it a most complete outfit.

### New Rambler Fire Fighter for California.

One of the first fighting machines to travel under its own power that has been seen in the far West has just been built by the makers of the Rambler and was designed by F. S. Craig, chairman of the board of public works at Long Beach, Cal. Before deciding to adopt the automobile type of fire fighting engine, the authorities undertook numerous and exhaustive tests to determine the relative merits of horse-drawn and gasoline-driven machines, and a great many various kinds of apparatus of both types were put through their paces at great length before any decision was reached, so that Thomas B. Jeffery & Company may well consider the selection of the product of their

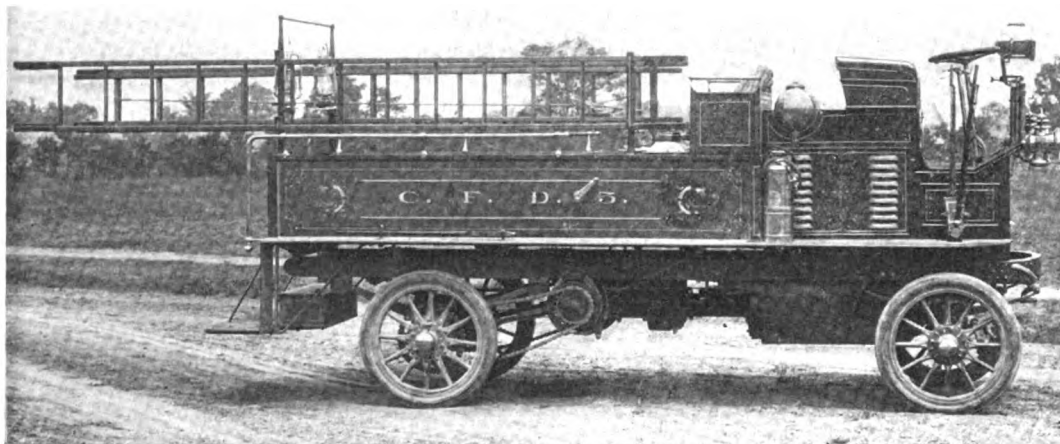

Knox Air-cooled 40-Horsepower Fire Fighter for Chicopee, Mass.

of this is to be found in the case of Chicopee, Mass., which has just received a new Knox fire fighting truck. This car is the product of the Knox Automobile Company, Springfield, Mass., and is said to be the first of its kind to be turned out in this country. It is equipped with a 40-horsepower air-cooled Knox motor of standard construction and has been designed especially for the use of country towns. It is for the Williamsett fire department, which is what is known as a "call department," having to cover the neighboring hamlets of Aldenville and Fairview.

Its construction where the chassis is concerned follows the lines of the Knox products more or less closely throughout, a sliding change-speed gear of the selective type providing three forward speeds and reverse constituting this step between the motor and the rear wheels, the final drive being by a countershaft and double side chains, the rear axle being a one-piece two-inch section of steel. The transmission and wheels are equipped throughout with Timken roller-bearings of liberal size for the load to be carried. Unusually powerful brakes are provided, the running brake, which is pedal operated, acting on the ends of the countershaft, while the emergency operated in the usual manner by side lever acts on drums attached to the rear wheels. The tire equipment consists of solids, measuring 34 by 4 inches, front and rear. In addition to the usual outfit of oil side and tail lamps, a 10-inch Rushmore searchlight supplied by a Prest-O-Lite tank is provided and wired so that it may be electrically lighted by a push button at the driver's seat. The car is geared to have a maximum speed of 20 miles an hour and will ascend grades of varying heights at from 5 to 15 miles an hour. The fire fighting equipment consists of two chemical engines of the Hallo-way type, 300 feet of chemical hose,

Kenosha plant a well won victory over a number of competitors.

The motor is of the four-cylinder vertical type, the wheel base is 120 inches, the regular 1908 Rambler tire equipment is used, while the car is guaranteed to operate under a weight of 3,000 pounds at a speed of at least 35 miles an hour. The rear portion of the car is used to carry 250 feet of hose, the chemical tanks being double 80-gallon receptacles under the seats.

A special starting device has been provided in the form of an inclined platform so that when the alarm is received the platform is tipped and the car glides out of the station without one second's delay. By keeping the gear-changing lever in the high-gear position the motor is thus started automatically without the necessity of delaying to crank it, and much valuable time is saved in getting under way, actual tests extending over a period of time demonstrating the fact that the power-driven apparatus could reach the fire in a fraction of the usual time.

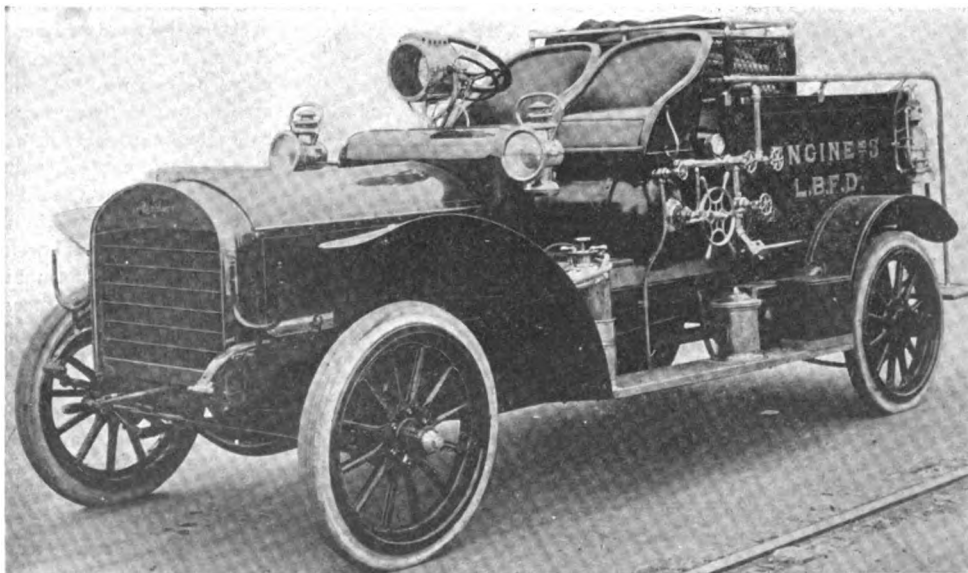

Rambler That Will Take Care of Fires in the Town of Long Beach, Cal.

## A FEW OF THE NEW EUROPEAN NOVELTIES

THE usual method of repair when a tire casing bursts and a new one is not available is to temporarily lace a gaiter round the defective spot and put in a new air chamber. The method is recognized as being defective, for the air chamber under pressure enters into the opening made and by reason of its

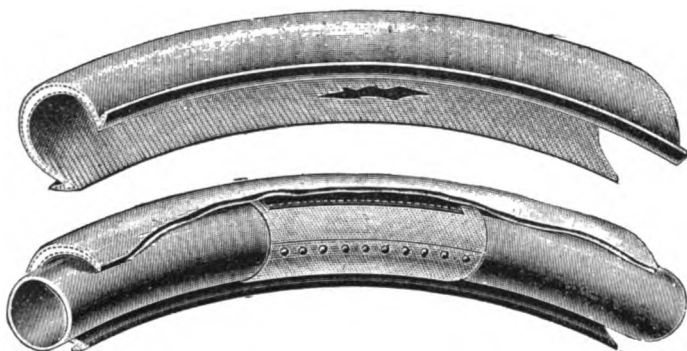

Frenchman Invents a "Corset" for Tire Repairing.

deformation and friction has a tendency to burst. A temporary repair produced by M. Eyquem consists in placing a rubber sleeve around the air chamber instead of the casing, and attaching by means of pressure buttons. One portion of the sleeve or corset, as the inventor has termed it, is faced with leather and it is this strengthened part which must be placed opposite the hole. If the blowout is of a serious nature, the hole in the casing might be stuffed and the ordinary sleeve placed over the tire in addition. This is not usually necessary, however, for ordinary road conditions.

### To Facilitate Changing Heavy Clincher Tires.

Until dismountable and quick-change rims have come into general use there will always be room for improved tools for the fitting of the larger sizes of pneumatic tires. One of the most popular of these on the European market is known as the Archimede and consists, as shown in the illustration produced from *Omnia*, of a couple of pivoted arms *A* and *B*, the former carrying at its base a mechanism operated by a handle. The pulley at the base of the arm *B* is free to turn in any direction;

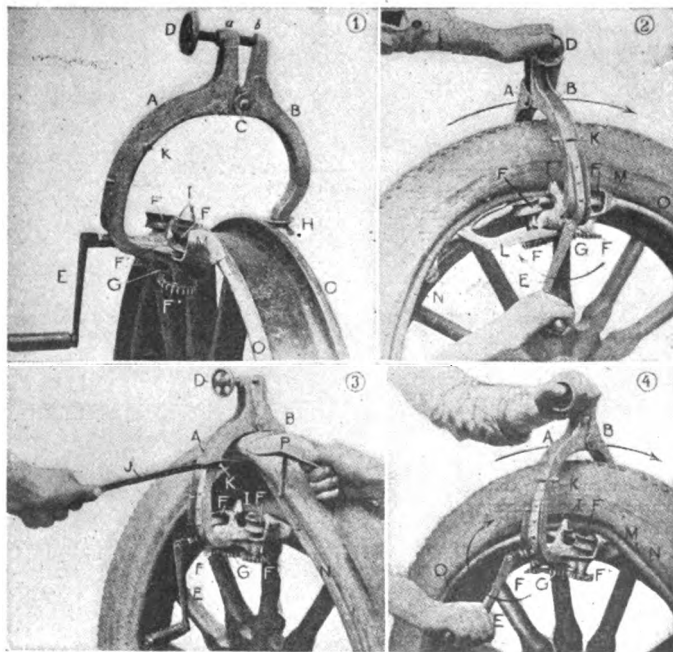

Tool for Replacing Large Tires on Clincher Rims.

the two pulleys *F F* are geared and obtain their movement from the rotation of the arm *E*. By means of the screw *D* at the head of the apparatus the three pulleys are made to bear on the face of the rim. As will be readily seen, the operation of the arm *E* would result in the entire apparatus revolving around the rim. But the operator holds the machine by placing his hand on the upper portion and it is the rim which is caused to revolve as the handle is turned. By reason of the forward finger *M*, which raises the tire, and the spool *L* which pushes it completely into position, the most difficult tire is mounted with a minimum of labor. The machine is of special value in garages and for use on dismountable rims which, by reason of their being detached, are often difficult to handle. Anyone who has labored and perspired over the task of forcing an obstinate five-inch clincher onto its rim on a warm summer's day when the mercury had climbed way up and the humidity was in proportion would appreciate what a convenience such a device would be under the circumstances.

### Convenient Aid for the Process of Valve Grinding.

The operation of the new valve grinding tool will be readily understood by reference to the accompanying illustration. A steel cut gear wheel at the top of the sleeve accommodating the shank and in mesh with a toothed quadrant allows of a movement of about two-thirds of a circle. To prevent scoring a

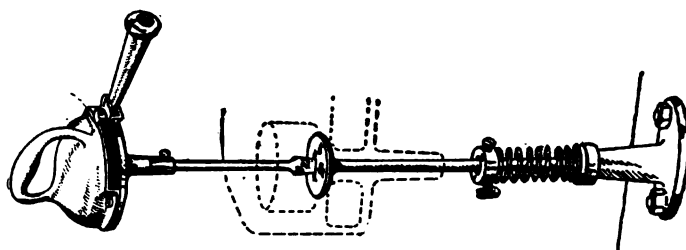

Strangely Familiar "Foreign" Valve Grinding Tool.

helical spring is supplied with each instrument to be fixed at the foot of the valve stem, so that as soon as pressure is removed from the head the valve lifts and the position of the particles of emery is changed.

### A Tire Maker's Advice About Loading.

It is not sufficiently realized by automobile purchasers that the manner of suspension of a car and especially the position of the rear axle have an enormous influence on the life of tires, declares the head of one of the largest tire factories in the world. A well suspended rear axle is an important factor in tire economy. Cars with short, harsh rear springs or overhanging bodies are ruinous to tires, the amount of work which the bandages are called upon to perform, especially if a closed body is carried, being enormous. It would be possible to mention many cars which, while not special offenders in the matter of weight, are tire devourers merely by reason of the position and suspension of the rear axle. Total weight is not all that should be considered in buying a car, automobiles that are equal in this respect showing enormous differences in their tire bills. While it is not possible to carry the full load between the axles, overhanging weight should be avoided as much as possible if tire economy is any consideration. This applies particularly to the closed car, and as this type represents a very substantial proportion of the total number of cars in use nowadays, it is easy to appreciate that disregard of it means a very large increase in the aggregate tire bill, though it is often so great even in the case of the individual that it is not necessary to refer to it *en masse* to make it appear imposing. Keep the weight as much between the axles as possible, and likewise keep it as low as possible.

## ITALY'S AUTO FACTORIES USE AMERICAN MACHINERY

**A**N interesting report has been filed with the State Department by Special Agent Capt. G. L. Carden, in which he describes two Italian establishments manufacturing automobiles and in each of which American tools are used.

The shop equipment of the Zust works at Milan is of a high order. About 70 per cent. of the tools installed are of American make. From Robert Zust Captain Carden learned that the necessary parts in stock at that time admitted of the assembling of about 200 machines. This firm makes only 50-horsepower engines, and every engine is carefully tested in the laboratory shop before being issued. The work required on these engines is of a very careful and painstaking sort, and it is evident at the Zust shops that a great amount of attention is paid to detail.

### Decreasing Number of Italian Motor Works.

The Zust shops in Milan are devoted only to automobile construction, and are independent of the machine-tool house of the same name at Lake Maggiore. The ownership, however, is the same. The Zust shops seem to have weathered the recent depression in the automobile business and may be expected to continue work. Of the 50 automobile concerns which sprang into existence in Italy during the past three years not more than ten or twelve will probably survive, and in some quarters it is doubted if at the end of the year there will be more than six or seven Italian automobile firms in the field.

Many tools at the Zust shops were found idle and covered up, while there appeared to be many new shipments on the floors still unopened. A little over a year ago at this time automobile makers were willing to pay high rates of advance for immediate delivery of tools. Among the American machine tools found in the Zust shops were observed standard-type machines from Brown & Sharpe, Hendey-Norton, Becker-Brainard, Cincinnati Milling Machine Tool Company, and Jones & Lamson.

### Isotta-Fraschini Works Have Largely American Tools.

The Isotta-Fraschini automobile works in Milan are working at present about 700 men. The installation of machine tools is one of the best I have seen in Europe. It may be estimated roughly that there are 400 machine tools in service on the floors, and that at least 70 per cent. are American. It was indicated that the great majority of these tools were purchased during the past two years. The plant is at present working about 50 per cent. as many men as during the recent busiest time. The following makes of American machine tools are installed here: Brown & Sharpe, millers and grinders; Potter & Johnson, automatic turret lathes; machines from the Gridley Automatic and Windsor Machine Tool Company; Lodge & Shipley, and Lucas Machine Tool Company, engine lathes; Cincinnati Milling Machine Tool Company and Becker-Brainard Company, millers; Warner & Swasey, hexagonal turret lathes; Baush Machine Tool Company, boring mills; Cincinnati Shaper Company, shapers; Gleason Company, gear cutters; Pratt & Whitney, lathes; Cincinnati Machine Tool Company, drill presses; Bickford Drill and Tool Company, drills; Landis Machine Tool Company and Norton Grinding Company, grinders; Baker Brothers and Hendey-Norton Company, shapers; Acme Machine Tool Company, automatic screw machines.

### Labor—Modern Equipment—Lack of Information.

The Isotta-Fraschini works are paying machinists between 45 and 50 centimes (100 centimes = 1 franc = 19.3 cents) per hour on a ten hours per day basis. An operator working at a Herbert lathe when questioned in my presence as to his pay exhibited a ring job on which he was engaged, and said he is able to finish about 15 of these rings per day. For each ring he received 45 centimes, which would mean 6.75 francs for a day's work. This rate of pay from an American viewpoint is extremely low. The work was well finished, but the speed was

very much below what is seen in American shops. One of the officials of the establishment informed me that his chauffeur, who worked hard at the shops during the day, was able to satisfy himself on a dinner in the near-by restaurant costing 60 centimes. This included no meat except, perhaps, a small quantity of sausage. Many of the Isotta-Fraschini workmen, it was said, did not know the taste of a beefsteak, and yet there is a fine organization at this establishment. The work is carefully done, the attention to detail is painstaking and with the magnificent equipment possessed this plant only needs speed to earn a high percentage of efficiency. About 75 per cent. of the Isotta-Fraschini outputs are for export, and it was stated that the falling off of orders from the United States during the past year had been felt by this firm.

The present Isotta-Fraschini shops are modern throughout. They were put up in 1905, and practically all the tools now in service were purchased subsequent to the opening of the new shops. All tools installed in this plant are arranged in parks and fenced off, the millers in one group, the lathes in another, the boring machines by themselves, the automatics together, and so on. The statement was made by an official that when a new tool is received from America about all the information they had was what could be gleaned from a printed description in English, and that the shop expressions puzzled them in translating.

The Isotta-Fraschini works are one of the few firms which have weathered the recent automobile depression in Italy. This establishment is at present well stocked up with machine tools, but should conditions improve, as every indication points, it will not be long before this firm will require additional machines, and especially so if any enlargements are made of the present shops. This establishment is turning out engines ranging up to 65 horsepower, and for racing machines to still higher powers.

### Present Conditions Satisfactory—Future Encouraging.

The industrial conditions in northern Italy at this writing (April 27) are good. Last year was the best year in the present decade, and the first quarter of the present is as good as the average showing for the year succeeding. This latter statement is based on the quarterly balance sheets required of all firms on the last day of March. My attention was called to the foregoing by Doctor Pirelli, of Pirelli & Co., Milan, which firm is working, 5,300 men. Their outputs are confined to electric submarine cables, land cables, and much of the rubber equipment utilized in automobile construction. The last-mentioned branch of the business has brought this firm in close touch with the automobile industry in Italy, and has placed the representatives of the firm in an excellent position to sum up the present situation. It is Doctor Pirelli's opinion that the automobile business in Italy will be in better condition by reason of the recent depression than otherwise. At first buyers of automobile stock could only see enormous dividends, but no account was taken of the cost of advertising, the cost of races, and other expedients resorted to to push sales, all of which expenses increased enormously as new firms came into the market.

At least 52 Italian automobile manufacturing firms were organized during the past two years, and of this number about 28 were established in Turin. The small firms have now been crowded back, and in many cases the small shops will take up new lines of industry. This they will be enabled to do by reason of the excellent equipment they possess. Large firms like Isotta-Fraschini and Fabbrica-Italiana-Automobil-Torino will continue to hold the field. These firms are at present working at a rate equal to about 50 per cent. and 65 per cent., respectively, of the rate demanded by last year's orders, and though the business is relatively quiet at their shops these larger firms are managing to hold their organizations together, and will be in position to take advantage of returning busy times.



## CONDITIONS FOR HOWER TROPHY.

Judging from the number who have stated their intention of entering runabouts to compete for the Hower trophy, the contest for which is held in connection with the annual reliability tour of the American Automobile Association, it looks as if there would be twice as many entrants this year as last. The Hower Trophy will be competed for under the same rules as the Glidden Trophy, a point system of scoring being employed, thus necessitating the presence of an observer on each competing car. The runabouts as a whole will be divided into two classes, to be known as Class A and Class B, the former comprising cars listing at less than \$1,500, and the latter cars listing at more than \$1,500. When the day's schedule is less than 7 1-2 hours, Class B will be allowed 10 minutes more in which to finish than Class A, and when the day's schedule is more than 7 1-2 hours, Class B runabouts will be allowed 15 minutes more. In the event of there being a tie between two or more of the competitors at the end of the tour there will be no lengthy run required to settle



Hower Trophy for Runabouts, A. A. A. 1908 Tour.

it, as the conditions provided for running off any tie that may occur are such that one extra day will doubtless be found sufficient to decide which is the winner.

The trophy itself marks a departure this year, as, instead of the bronze figure awarded last year, a handsome silver shield has been substituted. This shield is made with a convex surface, making it stand out against its rosewood mount in relief. The shield itself is a heavy piece of pure silver, handsomely chased and engraved, the ornamentation in the lower part consisting of the representation of a runabout containing its driver and a passenger. Immediately above is the space intended for the name of the winner, while surmounting this is the inscription which follows. This reads: "Hower Trophy for Runabouts, Fifth Annual Reliability Touring Contest of the American Automobile Association; Buffalo-Boston-Saratoga. Presented by Frank B. Hower." The trophy itself will be placed on exhibition in New York this week. Cups and similar articles have become more or less commonplace as automobile trophies, owing to the great number that have been offered during the past few years, so that any departure from the ordinary is very welcome.

## THE AUTOMOBILE CALENDAR. AMERICAN.

### Shows and Meetings.

- June 25-27.....—Detroit, Third Annual Summer Meeting of Society of Automobile Engineers.  
Dec. 31-Jan. 7.....—New York City, Grand Central Palace, Ninth Annual Automobile Show, conducted by the American Motor Car Manufacturers' Association, with Exhibits by the Importers' Automobile Salon, Inc., Alfred Reeves, general manager, 29 West 42d St.  
Jan. 16-23.....—New York City, Madison Square Garden, Ninth Annual National Show of the Association of Licensed Automobile Manufacturers. (Exact date to be announced.)  
February, 1909.—Chicago Coliseum and First Regiment Armory, Eighth Annual National Exhibition, National Association of Automobile Manufacturers. (Exact date to be announced.)

### Races, Hill-climbs, Etc.

- June 13.....—Hartford, Conn., Orphans' Day, Automobile Club of Hartford.  
June 13.....—Cleveland, Annual Hill Climb, Cleveland Automobile Club.  
June 17.....—Boston, Readville Track, Postponed Race Meet, Bay State Automobile Association.  
June 17.....—Buffalo, N. Y., Orphans' Day, Automobile Club of Buffalo.  
June 20-26.....—Albany, N. Y., Annual Five-day Tour of the Albany Automobile Club.  
June 24-27.....—New York and Philadelphia, Double-Head Endurance Run to Delaware Water Gap, under the auspices of the "Public Ledger" of Philadelphia.  
June 24-27.....—Chicago, 1,200-mile Reliability Run, Chicago Motor Club.  
June 27.....—Norristown, Pa., Skippack Hill Climb, Norristown Automobile Club.  
July 4.....—Lowell Mass., 250-mile Road Race, Lowell Automobile Club.  
July 4.....—Wildwood-by-the-Sea, N. J., Annual Speed Tournament, Motor Club of Wildwood.  
July 7-8.....—Buffalo, N. Y., National Convention of the American Automobile Association.  
July 9.....—Buffalo, N. Y., Start of the Fifth Annual A. A. A. Reliability Touring Contest.  
August 14.....—Chicago, Third Annual Algonquin Hill Climb, Chicago Motor Club.  
Sept. 5-9.....—San Francisco-Los Angeles Reliability Run, Automobile Dealers' Association of San Francisco.  
Sept. 14.....—Chicago, Annual Economy Run, Chicago Motor Club.  
Oct. 24.....—Vanderbilt Cup Race, Long Island Course, auspices of Vanderbilt Cup Commission.

## FOREIGN.

### Shows.

- Oct. 11-18.....—Paris, International Congress and Public Exhibition on Roads and Road Making for Modern Locomotion, French Ministry of Public Works.  
December.....—Paris, Eleventh Annual Salon de l'Automobile, Grand Palais, Automobile Club of France.

### Race Meets, Hill-climbs, Etc.

- June 1-18.....—Reliability Trials for Pleasure Cars, Automobile Club of Great Britain.  
June 14.....—Mount Cenis Hill Climb, for Voiturettes.  
June 9-17.....—Touring Competition for the Prince Henry of Prussia Prize, Germany, Imperial A. C.  
June 15-19.....—Scotland, Annual Scottish Reliability Trials.  
July 6.....—Voiturette Grand Prix, Dieppe Circuit (Automobile Club of France.)  
July 7.....—Grand Prix of Automobile Club of France, Dieppe Circuit.  
July 13-17.....—Ostend, Belgium, International Race Week, Automobile Club of Ostend.  
Aug. 12.....—Ardennes Circuit Races and Coupe de Liedekerke, Automobile Club of Belgium.  
Aug.....—France, Coupe de la Presse, Automobile Club of France. (Exact date to be announced.)  
Aug. 29-30.....—France, Mont Ventoux Hill Climb, Vauclussen Automobile Club.  
Sept. 1-8.....—French Voiturette Contest, Auspices "L'Auto."  
Sept. 6.....—Bologne, Italy, Florio Cup Race, Automobile Club of Bologne.  
Oct. 11.....—Berlin, Germany, Gordon-Bennett Balloon Race, Aeronautical Club of Berlin.

## HIGHER-PRICED CARS ARE SELLING IN THE SOUTH

By F. S. SLY, TRAVELING CORRESPONDENT FOR THE AUTOMOBILE.

**M**EMPHIS, TENN., June 2.—There is a general feeling of prosperity prevalent in this city, as dealers report that they are not only selling more cars this year than they did at the corresponding period of 1907, but the cars are higher-priced. Not a little of this increased business is credited to the very successful automobile show that was held here last April, under the auspices of the Automobile Dealers' Association of Memphis, of which Jerome Parker is president, and W. S. Bruce sec-



Valley of Tennessee River from Lookout Mountain.

retary. This stimulated interest in automobiling to a very great extent, and there is no doubt that it will be repeated next year, developing into an annual fixture with the trade here.

But despite the fact that Memphis can boast of no less than 500 cars in use, and interest in automobiling runs high, there is no such thing as a club. The roads are good in every direction out the county line, the best run being that to Brownsville, situated 120 miles from here, the road being good all the way. There are quite a number of cars represented, and garage facilities are good. The Memphis Automobile Company represents the Thomas, White, Franklin and Buick, beside the Baker electric, while the Jerome P. Parker Company has the Ford and Stoddard-Dayton, and McDonald Automobile Company the Mitchell, Rambler and Holsman; the Cullen-Butler Company have the Premier, Reo and Auburn; W. S. Bruce & Company have the Welch, Maxwell and Columbia; the Lilly Carriage Company represent the Peerless and Oldsmobile, and H. A. White has the Pope-Toledo and Cadillac. Of these dealers the first six maintain modern and well-equipped garages, such as are to be found in the largest cities.

### Nashville Not So Favorably Inclined.

**NASHVILLE, TENN., June 4.**—Nothing affords a more striking illustration of the value and influence of the presence of good roads as the condition of the automobile business here. While Memphis is congratulating itself on increased business and higher-priced cars this year, Nashville dealers complain that business is not as good as it was a year ago at this time. In spite of this, however, and the fact that the roads roundabout are in very poor shape, the city can boast of about 480 cars, as shown by the members of the license tags. The city streets are well paved, but outside good roads are few and far between, there being but two or three altogether, which goes to show that prosperity travels over well-paved highways. There was an automobile club here at one time, but interest in its welfare lagged to such an extent that it has finally gone out of existence. The pikes in this section need repairing so badly that autoists have got together and raised a subscription for the purpose.

Among the cars represented here are the Reo, handled by the Rock City Auto Company; the Rambler and Ford, represented by J. S. Roller; the Oldsmobile, White and Buick, for which the Southern Automobile Company is the agent; the Dorris and Stanley, handled by the Nashville Motor Car Company; the Stevens-Duryea, for which B. F. Bill is the agent; the Lambert, handled by J. W. Chester; the Mitchell, which is represented by the Keith-Simmons Hardware Company, and the Moon, for which Joseph Yarrow is the agent. With the exception of the last two, all these concerns maintain garages, and some of them are very well fitted up.

### Chattanooga Is a Paradise for the Autoist.

**CHATTANOOGA, TENN., June 6.**—With its rugged scenery, that is dotted with many of the historic battlegrounds of the Civil War, this part of Tennessee, and Chattanooga in particular, offers a great many attractions to the automobilist, whether resident or on tour. The country is one of the most mountainous parts of the State, but the roads are among the very best that the entire South has to offer, owing to the fact that they have been built and are maintained at the expense of the Federal Government. One of the most beautiful leads up to Missionary Ridge and goes along the entire length of it. No better example of what the government can do in the way of road maintenance could be desired than this. Another good road that is quite accessible to autoists leads to the top of Lookout Mountain, 1,750 feet above the city. The county likewise keeps its roads in the best of shape, and is now boring two tunnels through the ridges on opposite sides of the city, in order to save the climb over them. This will be one of the first instances in this country where engineering practice has really been applied to road building. Tunnels are quite common on European roads, but they are an extreme rarity here. These tunnels will be connected by a broad chert boulevard five miles long, and part of which is already under construction. This material abounds hereabout, and is largely used in road making.

There are no less than five good garages here, maintained by the following: The Chattanooga Automobile Company, handling the Franklin, Cadillac and Packard; the Joyce Automobile Com-



Chattanooga, That Reposes at the Base of Old Lookout.

pany, representing the Thomas and Buick; the H. H. Burke Automobile Company, the Ford and Reo; the Crescent Automobile Company, the White, Lambert and Model; and the H. D. Stebbins Auto Supply Company, the Rambler. Beside the foregoing there is the Wallace Buggy Company, representing the Stoddard-Dayton, Mitchell and Cartercar. There are from 150 to 200 cars in use in the city, but as yet there is no club.

# THE AUTOMOBILE

Vol. XVIII Thursday, June 11, 1908 No. 24

## THE CLASS JOURNAL COMPANY

Flatiron Building, Madison Square  
New York City

H. M. SWETLAND, President

### EDITORIAL DEPARTMENT

A. G. BATCHELDER, Managing Editor  
R. F. KELSEY, Associate Editor C. B. HAYWARD, Engineering Editor  
W. F. BRADLEY, Foreign Representative

### BUSINESS DEPARTMENT

A. B. SWETLAND, Business Manager  
LOUIS R. SMITH FRANK B. BARNETT  
W. L. RALPH, 1035 Old South Building, Boston, Mass.  
C. H. GURNETT, H. E. WESTERDALE, 1200 Michigan Ave., Chicago, Ill.

Cable Address - - - - - Autoland, New York  
Long Distance Telephone - - - - - 300 Gramercy, New York

### SUBSCRIPTION RATES:

United States and Mexico - - - - - One Year, \$3.00  
Other Countries in Postal Union, including Canada - - - - - One Year, 5.00  
To Subscribers—Do not send money by ordinary mail. Remit by Draft,  
Post-Office or Express Money Order, or Register your letter.

### FOREIGN SUBSCRIPTION AGENTS:

ENGLAND:—W. H. Smith & Sons, Ltd., 186 Strand, London, W. C., and all their  
railroad bookstalls and agencies throughout Great Britain; also in Paris at  
248 Rue de Rivoli.  
FRANCE:—L. Baudry de Saunier, offices of "Omnia," 20 Rue Duret, Avenue de  
la Grande Armee, Paris.  
GERMANY:—A. Seydel Mohrenstrasse 9, Berlin.

Entered at New York, N. Y., as second-class matter.  
The Automobile is a consolidation of The Automobile (monthly) and the Motor  
Review (weekly), May, 1902, Dealer and Repairman (monthly), October, 1903,  
and the Automobile Magazine (monthly), July, 1907.

Copies printed in 1905	- - - - -	730,000
" " in 1906	- - - - -	791,000
" " in 1907	- - - - -	888,900

## ONE MAN'S VIEWS ON THE RACING "WAR."

Concisely put, going directly to the meat of the argument, and presenting the views of a man interested in autoing since its American inception, no better editorial view of the so-called "war" for the control of racing could be written than the following communication from one who confesses that it is written just to ease his mind: Editor THE AUTOMOBILE:

The issue is now clearly defined, and, as I see it, it is the American manufacturer and the A. A. A. against the foreign maker and the A. C. A. The feeling among the foreign manufacturers toward their American competitors has progressed from contempt to respect, and from respect to fear. The foreigners realize that their "goose" which has been laying the "golden eggs" is in *extremis* and nearly cooked. The fact that all those having agencies in this country are advertising "bargain prices," and the falling off in value of importations this year of almost 50 per cent. as shown by the Custom House returns, tells the story in plain language, and indicates that the American public has finally awakened to the fact that the American manufacturers are now making as good, yes, better cars for American conditions than the foreigner.

The knell of the "importer" is sounded, and the spectacle of a metropolitan club, which is frankly striving for recognition as a national body, permitting itself to be used by the foreigners to bolster up their losing game, is pitiable and offensive to every true American who is patriotically wishing and working for the success of the American manufacturers. The American manufacturers are big enough and strong enough to decline to

submit further to the dictation of the foreign clubs, which are merely the manikins of a select few of the foreign manufacturers who have not hesitated to so frame their rules as to secure for themselves every advantage. The Automobile Club of France killed the Gordon-Bennett, for the sole reason that it held the French manufacturers down to an equal chance for success with the rest of the world, and instituted a race that would permit their entries to greatly outnumber the other.

The cause for the manifest unfairness of some writers for the daily press can be clearly traced, and most of them are doing their papers an injustice which will surely react on their business management when the American manufacturers, who are their best advertisers, begin to ask some pointed questions. It may be that the business managers will wake up and forestall the necessity of replying to such embarrassing inquiries.

The Vanderbilt Cup race will surely be held, and the foreign manufacturers, who still hope to market a part of their production in this country, cannot afford to withhold their entries, although they may adopt the plan of entries by individuals to "beat the devil around the stump," and I confidently predict that the Vanderbilt Cup race will have more entries of foreign cars than the A. C. A. "Grand Prize," if it is ever held.

Vive la Vanderbilt Cup!

Borough of Brooklyn, New York City. FRANK G. WEBB.

Mr. Webb is a representative type of the American sportsman who lends his aid to a pastime purely from the love of it. For years he has served the Long Island Automobile Club in various capacities, was instrumental in its organization, and was a factor in the formation of a national body. Early in the progress of autoing, he objected to a single club "lording" it over the other clubs. His views will find favor among those who think one's own country should come first.



## STRIVING FOR AUTO SIMPLICITY.

Generally speaking, it would seem that the time when a manufacturer deemed it incumbent upon himself to add a number of superfluous devices to his product to make the purchaser thereof think "he was getting his money's worth," to put it in the vernacular, had long since passed. Certain it is that the experienced buyer is not keen on parting with his money to acquire the maximum amount of steel and iron that a designer can work up into the shape of an automobile. Lightness consistent with adequate strength represents the guiding star of the up-to-date designer, but this end is not to be achieved by the addition of a number of useless, or what is the same thing, practically useless, devices, simply to enable the salesman to call the customer's attention to the fact that "It's all included in the price."

To mentally review the most successful American cars of to-day, and by these are meant those that have been successful from the very start, is to call to mind a succession of constructions distinguished more by their consistent simplicity of design than any other single feature. Even when reduced to its very simplest terms, the automobile is a piece of mechanism that consists of a comparatively large number of parts. That is, when only those that are actually necessary to enable it to perform its mission, are enumerated. Why, then, add things that only merit the contemptuous title of "doo-flickers," "go-dinkuses," and the like, from the experienced repairman? The day of "talking points" is over; the day of real merit has arrived, and merit needs no frills.

## BUFFALO'S A. A. A. CONVENTION ASSURED SUCCESS

THINGS are to be done on a scale of elaboration never before known in connection with such events at the National Good Roads and Legislative Convention of the American Automobile Association, to be held at Buffalo, July 6-8. The practical demonstrations will be in the nature of a complete education. A total of 79 miles of road, costing upwards of \$700,000, will be in actual course of construction, affording highway officers, contractors and others an unusual object lesson. The road-making will comprise highways of brick, macadam and gravel, and subsequently these various surfaces will be tested with different dust preventives. That this practical work will be as thorough as the entertaining, which is in charge of the Buffalo Automobile Club, is assured by the fact that it is in charge of a committee of very practical men, namely:

George C. Diehl, county engineer, Buffalo, chairman; Frederic Skene, State engineer of New York; John P. Kelly, division engineer, State of New York; F. H. Williams, resident engineer, State of New York; Joseph W. Hunter, vice-president, American Roadmakers' Association, and highway commissioner of Pennsylvania; W. E. McClintock, chairman of Highway Commission, Massachusetts; H. S. Sisson, chairman, Erie County Board of Supervisors, Good Roads Committee; John Satterfield, Automobile Club of Buffalo; Seymour P. White, Automobile Club of Buffalo; J. S. McFarland, Automobile Club of Buffalo; James D. Warren, Automobile Club of Buffalo; Henry P. Burgard, Automobile Club of Buffalo; and C. M. Croiner, Automobile Club of Buffalo.

This convention has grown to proportions beyond all the original ideas of its promoters, and has become an event of unusual importance. Not only are the automobile clubs and good roads associations sending delegates, but the governors of the several

States are appointing official representatives. Delegates already have been appointed by the automobile clubs of the A. A. A. in different cities from coast to coast. These clubs and their delegates are as follows:

Los Angeles, Cal., Automobile Club of Southern California, Charles B. Hopper, secretary and treasurer.

Newark, N. J., New Jersey Automobile and Motor Club, Paul E. Heller, J. H. Wood and F. A. Cresselmire.

Springfield, Mass., Automobile Club of Springfield, Mark Aitken, A. E. Lerche, M. T. White and S. L. Haynes.

Elyria, Ohio, Automobile Club, A. L. Stark, W. N. Gates and A. L. Garford.

St. Louis, Mo., Automobile Club, Roy F. Britton, Sam D. Capen.

Wilkesburg, Pa., Automobile Club, W. R. Stephens, A. J. Puffenburg and W. C. Cook. Alternates are S. L. Smith, Roy Wyse and J. M. Anderson.

Philadelphia, Pa., Automobile Club, Powell Evans, W. O. Griffith and S. Boyer Davis.

Philadelphia, Pa., Quaker City Motor Club, A. T. James, Edwin A. Lewis, Dr. W. J. Donnelly and L. E. French.

Chicago, Ill., Automobile Club, T. J. Hyman, Claude Seymour and A. R. Stumen.

Bridgeport, Conn., Automobile Club, S. T. Davis and A. L. Riker.

Wilkes-Barre, Pa., Automobile Club, Dr. E. C. Wagner and W. L. Raeder.

Malden, Mass., Automobile Club, A. E. Bliss, A. B. Tenny and C. P. Price.

Washington, D. C., Automobile Club, Robert B. Caverly, John K. Heyl and William D. West.

## LEADING TRADESMEN STRONGLY SUPPORT A. A. A. TOUR

HOW, more than any other contest of track or road, the A. A. A. tour for the Glidden trophy has come to be a criterion for the buyers of touring cars, is evidenced by the tangible results in sales noticed by manufacturers. H. O. Smith, of the American Motor Car Manufacturers' Association, says: "It is natural that men who want touring cars should be guided by the performance of cars in this event. To what other can they look? They are not buying cup racers for family use, and the track races offer them nothing in the line of information concerning a car's road efficiency. The demonstrations of a few miles they get are of comparatively little value, as every one knows. What they want to know is how a car runs day after day, on different sorts of roads, and how it travels in comparison with other cars. This they learn from the Glidden tour, as they do from nothing else, and with the new rules, which the manufacturers have approved, and the system of having observers on the cars, the tour will be of more importance than ever. That the buyers

of cars do watch this event and are guided by it can be proved in the most positive way. I know of many sales that can be traced as directly due to the showing made in the Glidden tour last year."

Another point of view, taken by a manufacturer who has an official position which makes it impolite for him to be quoted, is expressed as follows: "I think the agents have a right to expect the manufacturers to compete in the Glidden tour, no matter what the conditions of the trade. This event is known about and watched by automobilists all over the country, and it is mighty embarrassing for an agent to be asked why his car was not in the Glidden tour. Those who do not enter are apt to suffer from false inferences by buyers, who think that such non-contestants have lost confidence in their product. Our cars are all sold, but the agent is entitled to consideration just the same, and we want him to sell next year's cars as readily as he did this year's."

### WILDWOOD, N. J., TO CELEBRATE THE FOURTH.

PHILADELPHIA, June 8.—Preparations for the annual carnival of the Motor Club of Wildwood, which is scheduled for July 3-4, are proceeding apace. The affair will open with a regularity run on Friday, July 3, from this city to the sea, over a roundabout course yet to be announced. Fully two score local automobilists have announced their intention of entering this portion of the program, while as many more will take part in the run unofficially. Eight events will make up the program of short-distance brushes over the mile course on Central avenue boulevard, which will feature the second day.

### MR. BATCHELDER WILL WITNESS GRAND PRIX.

A. G. Batchelder, managing editor of THE AUTOMOBILE, accompanied by Mrs. Batchelder, sailed on Saturday, June 5, on the steamship *Oceanic* for a five weeks' trip abroad. A short time will be spent in England, after which they will visit Paris and later attend the Grand Prix on the Dieppe circuit, July 7.

Paris, June 9.—Marquis De Dion, president of the A. C. of France, and 300 others, are suffering from ptomaine poisoning, following the banquet held at the clubhouse this evening, and one man has already succumbed, while many others are very ill.



## MADISON SQUARE GARDEN SHOW TO BE JANUARY 16-23

AT the meeting of the board of managers of the Licensed Association, June 4, it was decided to hold the ninth national automobile show at Madison Square Garden, January 16-23. The meeting was well attended. Col. George Pope made a revised report of the eighth national show, held last November, and also called the attention of the members to the progress being made for the ninth national exhibition. Architects and decorators are now at work preparing material to be submitted to the show committee for the decorative scheme and general floor plan of the Garden, and it is expected that at the next board meeting a decision as to just how the Old Garden will look for the ninth national show will be reached.

As a result of the very satisfactory results attained under the show committee of last year the board were unanimous in re-electing Col. George Pope as chairman of the new committee, with Charles Clifton and Marcus I. Brock as his associates, and M. L. Downs, secretary. Mr. Brock was a member of the show committee up to the time he resigned to go with the Autocar

Company. He now represents the Autocar Company in association matters, and his efficient work on the show committee entitled him to reelection as a member of that committee.

Those present were: J. S. Clarke, Marcus I. Brock, Autocar Co.; W. C. Leland, Cadillac Motor Car Co.; M. S. Hart, Corbin Motor Vehicle Corp.; J. H. Becker, Elmore Mfg. Co.; H. H. Franklin, G. H. Stillwell, A. T. Brown, A. E. Parsons, H. H. Franklin Mfg. Co.; E. Hewitt, Hewitt Motor Co.; A. N. Mayo, Knox Automobile Co.; S. T. Davis, Jr., Locomobile Company of America; H. Lozier, Lozier Motor Co.; Wm. E. Metzger, Northern Motor Car Co.; F. L. Smith, Olds Motor Works; H. B. Joy, Packard Motor Car Co.; C. Clifton, George N. Pierce Co.; A. L. Pope, Pope Motor Car Co.; George Pope, Pope Mfg. Co.; E. D. Shurmer, Royal Motor Car Co.; G. E. Mitchell, Alden Sampson, 2d, R. H. Salmons, Selden Motor Vehicle Co.; E. McEwen, F. B. Stearns Co.; C. C. Hildebrand, Stevens-Duryea Co.; E. S. Church, Waltham Mfg. Co.; Thos. Henderson, Winton Motor Carriage Co.

## INDEPENDENTS' SHOW WILL HAVE SPECIAL TAXICAB EXHIBIT

RECOGNIZING the important position that town cars are taking in the commercial and pleasure life of this country, the show committee of the American Motor Car Manufacturers' Association, at its meeting last week, decided to have a special taxicab division in connection with the annual automobile show, to be held at Grand Central Palace, New York, December 31 to January 7. Aside from the exhibits of the regular manufacturers, there will be a certain amount of space set aside where each maker will have the privilege of exhibiting one model of a taxicab or town car if that is a part of his regular production.

With the eighteen exhibitors of foreign cars comprising the Importers' Automobile Salon, and the score or more of American makers that are supplying the demand for this type of automobile, it is expected that the division will be complete enough to satisfy the most exacting. Exhibitions in this section will be limited to a single model of taxicabs.

It will be the first attempt to segregate these cars, that are now such an important part of the motor car pastime and industry. There will, of course, be the usual section for commercial vehicles, with pleasure vehicles on the main floor.

Proposals for an entirely new plan of decorating the Palace were received and considered at the meeting, but no announcement of this feature will be made for some time.

Plans for the association's Western show were submitted, and a representative of the association is visiting Chicago this week to confer with the Chicago Automobile Club and the Chicago Motor Club.

In attendance at the meeting were H. O. Smith, chairman; Benjamin Briscoe and Alfred Reeves, of the A. M. C. M. A.; E. R. Hollander, representing the Importers' Automobile Salon, Inc., and Peter S. Steenstrup, of the Motor and Accessory Manufacturers.

### DELAGRANGE'S RECORD FLIGHT AT ROME.

PARIS, June 3.—Excluding the Wright brothers, in whom Europe has once more lost all faith, the world's new flying record belongs to Leon Delagrangé, Parisian sculptor and amateur aeronaut, who has remained above the Place d'Armes at Rome for a period of 9 minutes 30 seconds. It is the longest time any machine of the heavier-than-air type has remained aloft under official observation. The distance covered was not officially measured, but from the rate at which the apparatus was traveling is calculated at rather more than five miles. The experiment took place early on the morning of May 27 and was watched by the King and Queen of Italy and members of the Italian court, the King personally congratulating the French aeronaut on the successful results obtained. A second flight over the same ground gave as a result five minutes in the air, distance covered being approximately three miles. Delagrangé used his Voisin Frères aeroplane and Antionette eight-cylinder water-cooled engine.

The Italian populace apparently have been overexpectant in the matter of aerial flights, for when in the face of a strong wind Delagrangé soared aloft for a few hundred yards they were so disgusted that they expressed their feelings by uncomplimentary hissing. An Italian engineer who had been largely responsible for bringing Delagrangé to Rome for the public demonstration was set upon and very unceremoniously handled.

### REMISS AUTOISTS MUST PAY THEIR LICENSES.

INDIANAPOLIS, IND., June 8.—City Controller George T. Breunig opened his warfare against automobile owners who have not paid their city license fee this year by quietly filing about 100 warrants for their arrest last week. Up until noon Saturday a large proportion of this number had been arrested, thirty-eight being arrested Friday alone. Barely 200 of the 1,000 automobile owners of the city have paid the license fee this year. A large number of motorcycle owners are also delinquent, although the city officials are somewhat in doubt as to whether they should be taxed \$3 as an automobile, or \$1 as a bicycle.

### METUCHEN ESTABLISHES A NEW SPEED TRAP.

METUCHEN, N. J., June 9.—Another pitfall for the unwary driver who has a desire to "let her out a bit" has just been established on the road from this place to New Brunswick. It is placed just at the beginning of a fine straightaway stretch, and that its location is an excellent one for the purpose is shown by its large takings, \$400 in fines having been collected in one day. Autoists going that way should refrain from opening the throttle on anything that looks extra tempting for a spurt. There is also a trap being worked at Princeton, N. J., on the very edge of the town at the Kingston side. All automobilists are requested to keep these new speed traps in mind.

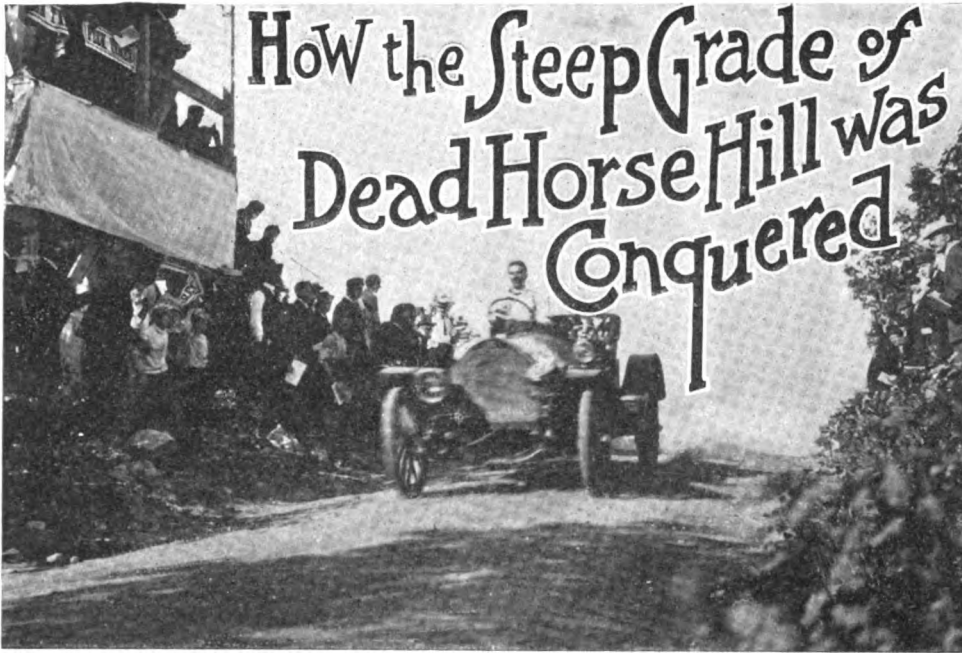

Thomas Detroit with Light as Pilot Winning Its Class Trial.

WORCESTER, MASS., June 8.—In the third annual automobile hill climbing contest, conducted by the Worcester Automobile Club, on famous Dead Horse Hill's mile long course, Saturday afternoon, June 6, premier honors for the gasoline class went to the Great Chadwick "Six," driven by Willie Haupt, who negotiated the course in 59.4-5, breaking the record of 1:01.2-5, established by S. S. Stevens, of Rome, N. Y., in a 90-horsepower Darracq, in 1906. Haupt's time was, however, lowered to 55.3-5 by L. F. Baldwin in a small steam car of Massachusetts manufacture.

The biggest place winner of the meet was the Thomas-Detroit, which captured four firsts and three seconds. Two of these firsts, for stock cars, 60.1 to 75-horsepower, and the free-for-all for stock gasoline cars, were captured by driver Levi Lorimer, another by J. S. Harrington, who drove his Thomas-Detroit in the free-for-all for amateurs, and the four first was taken by Oliver Light, who won the event for gasoline cars selling from \$2,001 to \$3,000. The Stevens-Duryea was a two-time winner, in both events being piloted by L. H. Hancock. The car was a consistent performer, the time in each event being 1:15.

In the little fellows' class the Maxwell, driven by Wright Pollard, scored a victory over the Ford, driven by H. H. Rogers, by the narrow margin of two seconds, and the Jackson, driven by E. P. Blake, won from the Maxwell and Selden in the class for cars ranging in price between \$1,251 to \$2,000.

The course was in perfect condition. The club had expended hundreds of dollars repairing and building it up, and it was sprinkled with calcium chloride, which did away with all dust. The mile of roadway utilized for the climb was policed by sixty officers, who had very little to do, for, because of a new State law, the course was closed to all traffic during the hours of the race, and the club had closed up its opening and had fenced it off on each side. The climb was also a success financially, as the club was allowed this year to

charge an admission to points of vantage along the course.

Weather conditions were ideal, and the automobiles owned the city for the day. More than 20,000 spectators lined the course throughout the afternoon. The climb was the Mecca for thousands of automobiles from all over New England, and it was easily the biggest and best the club has yet conducted, and the announcement that the club intends to make it an annual affair is most welcome.

There was but one protest. The Peerless people protested the Big Six Stevens-Duryea, on the ground that its body was not a stock body. The protest was upheld, and the car barred from the stock car event. However, in one stock event the Little Six Stevens-Duryea went in and trimmed the Peerless entry by two-fifths of a second.

Not an accident marred the running off of the events, which were cleaned up in good season. Barney Oldfield's nonappearance was a dis-

appointment to many enthusiasts, but it is supposed that the accident in which he and his wife and others figured in Lowell last Sunday night was what prevented him from coming.

A noticeable feature of the gathering of more than fifty cars of all sizes that comprised the entries was the fact that there was but a single representative of the air-cooled type. This was the 16-20-horsepower Cameron, and the manner in which it performed on the mile rise served to bring it strongly into the limelight, as it made the climb in 1:45.2-5, which is the record for gasoline cars up to 20-horsepower. The summaries:

GASOLINE STOCK CARS 60.1 TO 75 H.P.

Car	H.P.	Driver	Time
Thomas Detroit	40	Levi Lorimer	1:15
Peerless	57	J. B. McKinney	1:15 3-4

GASOLINE STOCK CARS 40.1 TO 60 H.P.

Peerless	57	J. B. McKinney	1:16
Stearns	60	Morgan Kent	1:16 2-5
Thomas Detroit	40	Oliver Light	1:16 3-5
Thomas Detroit	40	Levi Lorimer	1:20 2-5

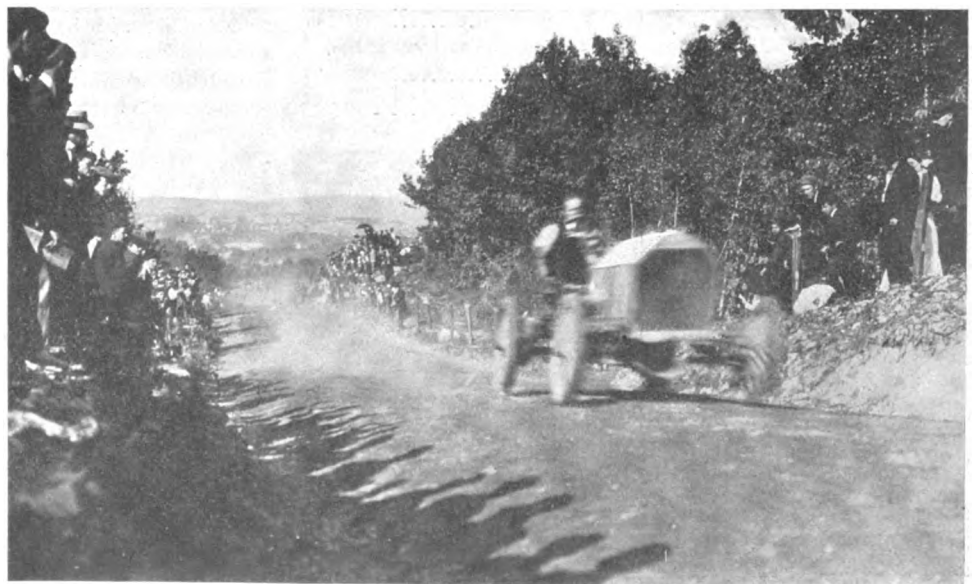

Willie Haupt Sending up the Great Chadwick Six in :59.4-5.

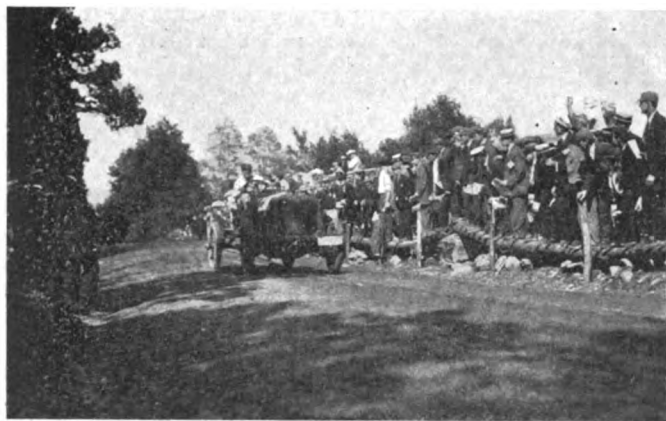

Stevens-Duryea That Captured Two Events in 1:15.

GASOLINE CARS 24.1 TO 40 H.P.

Car	H.P.	Driver	Time
Stevens-Duryea	35	L. H. Hancock	1:15
Thomas Detroit	40	L. Lorimer	1:17
Thomas Detroit	40	Oliver Light	1:20 2-5
Corbin	32.4	John Dower	1:20 2-5
Corbin	32.4	James Corbett	1:20 4-5
Knox	30.6	Wm. Bourque	1:23 2-5
Marmon	40	F. E. Wing	1:42
Marmon	40	J. E. Hines	1:49 1-5
Wayne	32	Fred Allen	2:00 2-5
Stoddard-Dayton	35	John Miller, withdrawn.	

GASOLINE CARS 15.1 TO 24 H.P.

Buick	22	Chester M. Stanley	1:49
Overland	22	J. E. Pugh	2:42 4-5

FREE-FOR-ALL AMATEURS—STOCK GASOLINE CARS ONLY.

Thomas Detroit	40	J. S. Harrington	1:18 2-5
Peerless	57	J. L. Snow	1:18 4-5
Marmon	40	F. E. Wing	1:53
Stearns	60	Morgan Kent	2:31

MOTORCYCLES—PROFESSIONALS.

Indian	5	C. F. Hoyt	1:04 2-5
Indian	5	Herbert Clark	1:29
Indian	5	Howard Clark	1:31
Indian	4	E. N. Allen	1:51 2-5

CARS OF ALL TYPES AND MOTIVE POWER.

Stanley	30	L. F. Baldwin	:57 2-5
Chadwick	60	Wm. Haupt	:59
Berliet	54	H. F. Grout	1:03 1-5
Stevens-Duryea	50	P. J. Robinson	1:06 3-5
Mercedes Flying Dutchman	90	Charles Basley	1:07
Columbia	28.9	J. J. Coffey	1:15
Knox	30.6	Wm. Bourque	1:15
Corbin	36.1	John Dower—did not finish	

GASOLINE STOCK CARS, \$850 OR LESS.

Maxwell	14	Wright Pollard	2:13
Ford	20	H. E. Rogers	2:15

WORCESTER COUNTY CHAMPIONSHIP.

Stanley	20	F. Dewey Everett	1:16
Thomas Detroit	40	J. S. Harrington	1:16 4-5

GASOLINE STOCK CARS, \$851 to \$1,250.

Buick	22	Chester M. Stanley	1:40 2-5
Cameron	21	F. F. Cameron	1:45 2-5

GASOLINE STOCK CARS SELLING FROM \$1,251 TO \$2,000.

Jackson	35	E. P. Blake	1:53
Maxwell	24	L. S. Tyler	2:06
Selden	28	A. R. Miles	2:32



The Little Maxwell Winning in the \$850 Class.

FREE-FOR-ALL—STOCK GASOLINE CARS ONLY.

Car	H.P.	Driver	Time
Thomas Detroit	40	Levi Lorimer	1:17 1-5
Corbin	32.4	John Dower	1:19 1-5

GASOLINE CARS SELLING FROM \$2,001 TO \$3,000.

Thomas Detroit	40	Levi Lorimer	1:15
Thomas Detroit	40	Oliver Light	1:16 1-5
Knox	30.6	Wm. Bourque	1:20 1-5
Corbin	32.4	James Corbett	1:22
Corbin	32.4	John Dower	1:22 1-5

GASOLINE CARS FROM \$3,001 TO \$4,000.

Stevens-Duryea	36.1	L. H. Hancock	1:15
American Roadster	44.1	Arthur J. Andrews	1:19 3-5
Marmon	40	F. E. Wing	1:41 1-5
Marmon	40	J. E. Hines	1:49 1-5

GASOLINE CARS, \$4,001 AND OVER.

Peerless	57	J. B. McKinney	1:16 1-5
----------	----	----------------	----------

RECORD OF HILL—OPEN TO EVERY TYPE.

Chadwick	60	Wm. Haupt	1:00
Berliet	54	H. F. Grout	1:03 3-5
Mercedes	90	Charles Basley	1:04 1-5
Stevens-Duryea	50.1	P. J. Robinson	1:05 2-5
Corbin	36	John Dower	1:10 2-5

SPECIAL EXHIBITION EVENT OPEN.

Stanley	30	L. F. Baldwin	:55 3-5
Chadwick	60	Wm. Haupt	:59 4-5
Berliet	54	H. F. Grout	1:02 2-5
Stanley	30	Fred Marriott	1:19 2-5

COMING EVENTS IN WILLIAM PENN'S BURG.

PHILADELPHIA, June 8.—Interest in the *Public Ledger's* tournament in the Poconos, scheduled for June 24, 25, 26 and 27, has increased here with the elimination from the table of fixtures of the various hill-climbs hereabouts. When the Orphans' Day stunt, next Wednesday, and the Quaker City Motor Club's first track meet of the year, scheduled for next Saturday, are out of the way, the Monroe countyites' carnival will have a free field. A little mix-up with the Norristown Automobile Club, due to a conflict with its Skippack hill-climb on the 27th, was side-stepped by transferring the Delaware Water Gap open and the Canadensis amateur hill climbs to Thursday, thus allowing prospective entrants ample time to take in both.

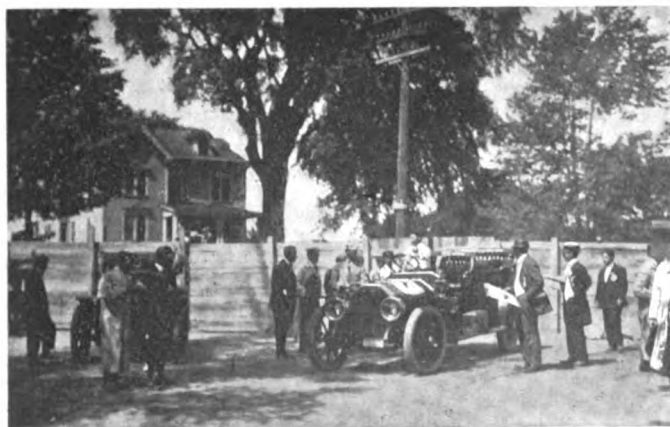

Peerless and Driver McKinney Ready for the Start.



Waiting at the Foot of the Hill for Starting Signal.

## THINGS THAT ARE GOING ON IN CLUBDOM

### NEWS OF SOME OF THE CONNECTICUT CLUBS.

HARTFORD, CONN., June 8.—The Automobile Club of Hartford will conduct a series of gymkhana games at Charter Oak Park, June 19, in connection with the Hartford Hospital Benefit. H. P. Maxim and C. H. Gillette have nearly completed the details, and everything points to the complete success of the occasion. It was part of the original plan to hold races on the celebrated Charter Oak track, but the condition of the course at this time does not make this feasible.

The first hill climb of the recently organized Automobile Club of Rockville promises to be a lively affair. There have been promised up to date the following cars: Isotta, Stearns, Simplex, Mercedes, Columbia, Pope-Hartford, Knox, Mitchell, Maxwell, Ford, Oldsmobile, Thomas, Packard and Franklin, and the chances are good that Bernin's Renault will negotiate the straight-away course June 30. H. P. Maxim will be starter, and C. H. Gillette referee. In all probability the Hartford club will conduct a run to the hill. The winners of perfect scores in the recent endurance run conducted by the Automobile Club of Hartford are each to receive a bronze medal containing a fac-simile of the Kohn trophy. This was presented by Albert M. Kohn, of the House Committee.

The sign post committee of the Automobile Club of Hartford will post the road to Worcester by way of Rockville. The main route from Hartford to Worcester by way of Springfield is now undergoing repairs above Palmer, which necessitates a detour from the main highway. Many tourists have cut out Hartford altogether in consequence, and but few of them are aware that Worcester and Hartford are to be reached by the Rockville route. The committee will also post various other routes throughout the State.

### A. C. A. TO HOLD SERIES OF PLEASURE TOURS.

NEW YORK, June 8.—According to an announcement made by the Bureau of Tours of the Automobile Club of America yesterday, the club will hold the first of a series of tours from June 19 to 28, the "ideal tour" route of New England having been selected for the first run. From New York the first day's itinerary takes the tourists to Waterbury, Conn., thence to Manchester, N. H., on the second day, and from there to Sunapee Lake at the close of the third day. Bretton Woods will be the goal on the fourth day, and the tourists will stop over a day there. On the fifth running day the night stop will be Poland Springs, Me., while the next day's run will take the tourists into Boston, where another one-day stop will be made. Two days will be consumed on the run home from Boston, Waterbury, Conn., again being made the stopping place for the night. A plan has been devised to avoid the dust nuisance as much as possible, and details of it will be published later. In the morning of each day the low-powered cars will be sent away first, then the medium-powered and lastly the heavy cars, while after lunch the order of starting will be reversed. There will be no entry fee for the tour, as it is simply for pleasure.

### TOLEDO CLUB BEGINS GOOD ROADS CAMPAIGN.

TOLEDO, O., June 8.—At a dinner given at Bowling Green, O., last week, nearly a hundred city and county officials gathered together at the invitation of the Automobile Club of Toledo to talk over the problem of good roads. Officials representing the city of Toledo, Lucas, Wood and adjoining counties, as well as smaller towns attended at the Hotel Milliken, to discuss the best methods of road building and improvement. It was decided to postpone definite action until a later meeting, which will be held in the near future. The club went on record as being utterly opposed to reckless driving and scorching.

### HOW PITTSBURG GAVE ITS ORPHANS A RIDE.

PITTSBURG, PA., June 8.—About 750 orphans of Greater Pittsburg enjoyed a long ride which the Automobile Club of Pittsburg gave them in 104 autos which were provided for the occasion, Wednesday, June 3. A clear, fair day made the event one of the most enjoyable the little folks have ever taken part in. At 10:30 the automobiles proceeded to the different institutions and gathered up the children and were at Carnegie Lake for lunch.

The procession of automobiles attracted much attention as it passed through the main streets of the city. One of the pleasing events of the day was the meeting with Speaker Joseph G. Cannon of Illinois, who was touring Pittsburg in the car which had brought him from Washington. He made a neat little speech to the children, and in return was greeted with rousing cheers as a candidate for the Presidency. The children were taken through all the parks of the city under the guidance of Edward Kneeland and George E. Painter, who with Chief Ordinance Officer Murray A. Livingston acted as escorts for the crowd.

### ACTIVITIES OF THE TWIN-CITY AUTO CLUBS.

MINNEAPOLIS, June 8.—One of the latest innovations introduced by the Minneapolis Automobile Club is a registration bureau for drivers. Whenever a man applies for work, he registers, and his record is then looked up and the membership of the club kept posted as to those applicants that are desirable, or otherwise. June 12 has been set down as the date of the first annual celebration of Orphans' Day. Preparations are being made to entertain 400 children, and in addition to the parade and ride through the Twin Cities they will be taken out to Lake Minnetonka and given a real country picnic day. The club has also made arrangements to carry the delegates to the national convention of park commissioners, which convenes here in August, on a trip through the parks.

The St. Paul Automobile Club's headquarters now boasts of a novelty in the shape of an up-to-date Chinese restaurant, presided over by a slant-eyed chef.

### ROCHESTER CLUB BEGINS A LIVELY PROGRAM.

ROCHESTER, N. Y., June 9.—Beginning to-morrow, a seven-day, non-stop endurance run will be held, under the auspices of the Rochester Automobile Club. The route covers a circuit of practically eighty miles, and takes the contestants through the center of the city twice on each round trip. A penalty of two points for each minute the engine is stopped will be incurred, and one point for every minute consumed in making other repairs, with the exception of tires. The contesting cars, all of which have been entered by local concerns, are the Gearless, Mora, Selden, Thomas, Mitchell and Studebaker.

This is only the opening of more than a month's activity, as the club has entered a team in the A. A. A. Reliability tour, and has also planned a big run to the Buffalo convention July 8. The celebration of Orphans' Day has been postponed to August 1. The membership of the club is now 481, and Secretary Bert Van Tuyle is confident that the 500 mark will soon be passed.

### VIRGINIA ADDS TO ITS GROWING CLUB LIST.

SUFFOLK, VA., June 8.—The latest addition to the rapidly growing list of automobile clubs in this State is the Automobile Club of Suffolk. It was organized here last week with the following officers: President, C. A. Shoop; vice-presidents, W. N. McAnge and B. L. Saunders; secretary and treasurer, R. L. Gaskins. The club will devote its endeavors largely to the matter of road improvement, which is badly needed in this section.



## ACTIVITY IN FRANCE'S GRAND PRIX PREPARATIONS

PARIS, June 1.—In all probability there will be 52 cars in the Grand Prix on the Dieppe circuit, July 7, for Porthos has just put in a third car, at double fees, and both Rochet-Schneider and Mors are expected to enter full teams of three each. Even without any additions the number stands at 46, which is a record in point of numbers, last year's Grand Prix uniting 38 cars, and the speed test of 1906 bringing together 34 competitors. Taking the two events together, it is by far the largest automobile race gathering ever held on a course, the total entries for July 6 and 7 reaching no less than 114, of which 62 are in the voiturette contest. At a time when touring competitions in Europe are, with one or two rare exceptions, failing to attract entries, this is strong proof of the popularity of racing, the announcement of the conditions of the race a long time in advance being responsible for the record entry.

Practically all the racers are on the road. Though drivers on the whole did not receive their 1908 cars until the end of May, they have by no means been idle, every European connected with the Grand Prix having been out on last year's models or on fast touring cars since the middle of February. Szisz, of the Renault team, as soon as he received his Grand Prix racer, immediately set out for trial trips in the neighbourhood of Orleans. Caillois and Dimitri, who will complete the team, now have their machines on the road.

Externally the Renault racers are identical with those of last year, and it is only by close examination that differences can be detected. As a matter of fact, however, they are entirely original cars, the regulations making it impossible to make use of 1907 racers in any way.

All three Bayard Clement racers are on the road in the hands of Rigal, Gabriel, and Hautvast. Hemery was one of the first to receive delivery of a racer, and has his Benz thoroughly tuned up already. Heath, Farman and Cissac have just received their Panhards, chain-driven machines differing entirely from the hook-nosed racers with radiator on the dash which failed to

finish last year. Nazzaro, Lancia, and Wagner, still looked upon as the most formidable team, are believed to be yet waiting for their new cars. Not much can be learned of the Fiat racers, but from the fact that Wagner is still around Paris his 1908 racer cannot be ready.

It is quite probable that a second tire and gasoline station will be established on the Dieppe circuit in order to diminish the risk of any car being left stranded through lack of tires or any tool. Last year all work had to be done opposite the grandstand, in full view of the spectators, and it was intended to repeat this plan. Competitors, however, have complained of the distance, and the Sporting Commission is considering the advisability of establishing a second station at Fresnay-Folny, about half way round the course.

According to the supplementary regulations just issued by the Automobile Club of France, Grand Prix racers must be presented for weighing in July 3 and 4 between 8 A. M. and noon and 2 and 7 P. M. Verification of the cylinder bore can be made at any time and place, on giving notice to the Sporting Commission after July 1. When they have been examined and found correct each cylinder will be stamped in a suitable manner and spare cylinders may be treated in the same manner.

At the weighing-in shed near the starting point the cars will be placed over a bed of sawdust and the engine run at full speed for a few minutes in order to verify the exhaust. If the sawdust is disturbed the exhaust pipe will have to be altered, until no disturbance is created, or if that is impossible the car will be disqualified. Where the maximum weight of 1,100 kilos is not attained by the car with its lightest set of tires, without water, oil, gasoline or spare parts, the amount must be made up by the addition of a bag of ballast sealed and attached to the car by a lead seal. At the end of the race the first four cars must have their cylinder dimensions verified and their carbureter and inlet pipe examined to ascertain that no "doping" has taken place.

## THE THOMAS GRAND PRIX CANDIDATE ARRIVES AT DIEPPE

DIEPPE, FRANCE, June 3.—America's only team in the Grand Prix has arrived here and is now making arrangements for a center near the course from which to train for the race of July 7. Harry S. Houpt, who is accompanied on his European trip by Mrs. Houpt, and their niece, Miss Dorothea McCartmey, is acting as race manager and trainer and believes that he will have five weeks in which to prepare the Thomas car and it should make a great showing. A mistake which has been made by every previous American entrant in a European race is too late arrival on the ground, with the result that the cars have never been properly tuned up and drivers have had an imperfect knowledge of the course. Even with this early arrival, the Thomas racing car will not be allowed on the course except on a few special days yet to be appointed by the Racing Board, that authority having rigorously barred everything but stock touring cars from the Dieppe triangle.

Changes were made at the last moment in the composition of the Thomas team, the men who came over on the *Adriatic* being Lewis Strang, who will drive the car; William Knepper, the mechanic, and Montague Roberts, reserve driver. In addition two skilled mechanics from the factory are with the party. Strang has had some experience of the Dieppe course, for last year he was here as mechanic for Walter Christie, who, to tell the truth, failed to impress the Frenchmen with the speed qualities of his front-drive vehicle. Knepper, the mechanic, was

last in France for the 1905 Gordon Bennett race in Auvergne, when he accompanied Herbert Lytle on the Pope car, which had the distinction of being the first American automobile to officially finish in a European speed test.

### French Makers Don't Care for Fuel Race.

PARIS, June 3.—French constructors do not appear to appreciate the efforts of their national club to provide them with a fuel consumption race for touring cars, the Coup de la Presse having closed with but 16 cars engaged. Last year a week's preliminary touring was followed by a long distance speed test on the Lisieux circuit in Normandy. This year the touring portion has been abandoned, the cars being required merely to prove their speed and economy in a two-day race on the Dieppe circuit, August 3 and 4. The cars engaged comprise teams of three from Peugeot, Cottin & Desgouttes, De Dion, Benz, Gobron, and a single car from Westinghouse. As will be seen, all are French with the exception of the Benz. The fuel allowance is 19 liters per 100 kilometers, which works out at the rate of approximately 15 miles to the gallon.

A similar event for small cars to be held on the same circuit on a preceding day has united but ten engagements, three being from Berliet, two from Peugeot, two from De Dion, and one each from the Vinot, Gladiator, and Rebour. These smaller cars are allowed 10 liters per 100 kilometers, or equal to about 28 miles to the gallon.

**POPE RECEIVERS MAKE FAVORABLE REPORT.**

HARTFORD, CONN., June 8.—The receivers of the Pope Manufacturing Company, Albert L. Pope, George A. Yule and Albert J. Tamlyn, have filed a petition to Mahlon Pitney, chancellor of the State of New Jersey, setting forth the results of business since their appointment and asking that they be authorized to manufacture 700 Pope-Hartford cars of the 1909 model, also 50,000 bicycles. In response to this petition the stockholders and creditors of the company are cited to appear in the chancery chambers at Newark, Wednesday, June 17, at 10 A.M., to show cause, if any, why the receivers should not be authorized as mentioned above. It goes without the saying that Hartford interested desire the granting of the petition.

The outlook at the Pope No. 1 plant at this time is very encouraging. The receivers state that 500 machines of the 1908 Pope-Hartford model have been built and 400 have already been shipped and the balance will be out shortly. An inventory of the property in their possession and the disposition made of it is also given. The report shows that the operations of the Hartford plant since the appointment of the receivers up to May 1 have resulted in a net profit of approximately \$215,890.20, and the profits for the year ending on July 1 are estimated to be \$405,022.80. The profits of the Westfield factory net \$35,797.49, and the profit for the year is estimated to be \$69,399.47. The factory at Hagerstown, Md., according to the receivers, has been operated at a profit, which up to May 1 amounts to \$17,546.85. The factories have been disposed of in Illinois, two of which netted \$236,000.

**MRS. TEAPE AND DAUGHTER NEAR OMAHA.**

The first stage of the transcontinental trip which is being made by the two ladies who are touring from Portland, Maine, to Portland, Oregon, was completed with their arrival in Chicago on June 1. Leaving Portland, Maine, on May 14, in an 8-horsepower Waltham-Orient runabout, Mrs. E. E. Teape and her daughter, Mrs. Mackelvie, inaugurated the first attempt of a transcontinental tour by women. The trip from Portland to Buffalo was uneventful, but beginning at Buffalo the road conditions after the recent rains made traveling very heavy and burdensome. This was especially so in Ohio and Indiana, where in some instances not more than four miles an hour could be made.

In writing of the trip, Mrs. Teape was enthusiastic over the treatment which she received from autoists, calling attention to the good-fellowship which existed. In nearly every instance pilot cars and guides were willing to put them on the right road, without loss of time or annoyance of misdirection. The tourists left Chicago June 2, headed for Omaha. When the condition of the roads is considered, the fourteen days from Portland to Chicago is most remarkable time, and Mrs. Teape is confident that she will be able to reach Portland, Oregon, by July 1.

**INDIANIANS CELEBRATE AUTOMOBILE DAY.**

CRAWFORDSVILLE, IND., June 8.—Under the auspices of the Commercial Club, automobile day was observed here last Thursday by several hundred automobile owners and their friends. The main feature was a parade during the afternoon, covering several blocks in length. There were visiting drivers from Kokomo, Frankfort, Indianapolis, Lafayette and South Bend in large numbers, Kokomo alone sending about fifteen automobiles. Prizes were awarded to winners of the various events.

Edgar Apperson of Kokomo, driving his four-cylinder Jack Rabbit, won the hill climbing contest, the egg race and the four blocks sprint. The Indianapolis Motor Car Company of Indianapolis was awarded two prizes on their Rapid Pullman, which was the largest car in the parade and also carried the most passengers, having forty-three passengers on board. Frank Sweigert of Kokomo was adjudged the best gentleman driver, and won the obstacle race, there being a number of other events of interest on the program as well.

**GREAT WESTERN SHOULD HAVE HAD CREDIT.**

ALBANY, N. Y., June 8.—In reporting the hill climb held under the auspices of the Albany Automobile Club, on Menands hill, May 23 last, an error crept into the report which was published in THE AUTOMOBILE a few days later. This was in the issue of May 28, page 763, and in Event 8, which was for gasoline touring cars up to \$1,250, it was stated that Cadillac was the winner. This was an error, as there was no car of this make entered in that event, the only contestants being a Great Western car, made by the Model Automobile Company, Peru, Ind., and which carried the number 12, and a Buick. The former won in 1:36, while the second entrant could not do better than 2:40. The injustice of the error is the greater as this \$1,250 car bettered the times of several other cars ranging from \$1,700 to \$2,500, from 3 to 9 seconds.

**CORBIN WAS A WINNER AT ALBANY.**

In the account of the very successful hill-climb held under the auspices of the Albany Automobile Club on Menands hill, May 23, mention of the event for runabouts ranging in price from \$2,000 to \$3,000 was inadvertently omitted altogether. The error was a great injustice to the Corbin, the winner in this class, as its time of 1:02 1-5 was not alone much better than any of its competitors in this event, but also lowered the times of all but the first to finish in the \$3,000-and-over runabout class, and all but the first and second to finish in the free-for-all runabouts, some of which listed at \$5,000 or over.

**PREST-O-LITE FACTORY AGAIN BURNS.**

INDIANAPOLIS, IND., June 8.—For the third time in less than a year the local plant of the Prest-O-Lite Company was damaged by a series of small explosions Saturday. While the loss to the plant was small, the damage to buildings in the neighborhood, including St. Vincent's Hospital, was much larger. The cause of the explosions has not yet been determined, according to Carl G. Fisher, of the Fisher Auto Company, who, with James A. Allison, owns the plant.

The loss on the Prest-O-Lite plant is estimated at from \$1,000 to \$2,000. Other losses have not been fixed.

**RESULTS OF WASHINGTON ENDURANCE RUN.**

WASHINGTON, D. C., June 9.—The Thomas-Detroit won the cup for the lowest score made by a touring car in the 164-mile endurance run of the Washington Automobile Club, which was run to-day. The Stearns finished first in the roadster class, while the Ford and Buick runabouts were tied in the third division. The course lay through three States, Maryland, Virginia and West Virginia, and included some of the roughest roads in the eastern section of the country.

**STEARNS DRIVER LEINBACH IS BANQUETED.**

BALTIMORE, MD., June 8.—E. L. Leinbach, who piloted the Stearns car to victory in the 100-mile race at Pimlico, on Decoration Day, was the guest of honor at a dinner given to owners of Stearns cars and their friends by President John H. Schaab, of the E. L. Leinbach Automobile Company, local agents for the car. The dinner was held at Mount Holly Inn. The cup won by Mr. Leinbach was on exhibition, and was greatly admired.

**REO COMPANY CUTS ANOTHER MELON.**

LANSING, MICH., June 5.—A dividend of 40 per cent. has just been paid by the Reo Motor Car Company of this city to the company's stockholders. This is the second dividend of the year, the first, of 20 per cent., having been paid on April 18. This makes a total of \$600,000 paid in dividends so far this year on the capital stock of \$1,000,000. The company is now making thirty cars per day.

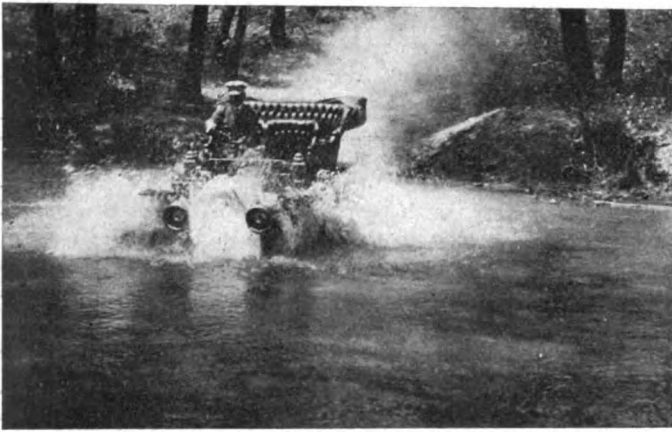

Fording Southern Streams in Canvas Protected Franklin

Salesman L. E. Hoffman has driven this 1908 Type D Franklin demonstrator over 10,000 miles, visiting all Franklin dealers in the South. Fording streams in that territory is so frequent that he has a canvas bag affair that he slips over the front end of the hood to prevent water splashing on the motor.

### QUAKER CITY NOW HAS TAXICAB SERVICE.

PHILADELPHIA, June 8.—Last Monday, with ten Thomas vehicles, the first taxicab service was inaugurated here, operations being confined to the various local stations of the Pennsylvania railroad until the advent of additional permits an extension of the service. The public took to the innovation immediately, and there were few intervals of rest, either day or night, for the drivers. Headquarters for the taxicab service have been established at the big new garage of the Bergdoll Motor Car Company, at Broad and Wood streets, and the management has been placed in the hands of Robert A. Parke, former manager of the taxicab branch of the Thomas factory, and who later established the taxicab service in Washington, D. C.

The rates of fare are considered decidedly moderate. Thirty cents is the charge for the first half mile, not exceeding four persons, and ten cents for each additional quarter mile, with a charge of ten cents for each six minutes of waiting. Trunks and packages carried outside call for additional payment of 20 cents each. There is no charge for calls within a radius of half a mile of the cab stand; outside that limit the charge is 20 cents a mile. Passengers dismissing a cab less than three miles from the stand are not charged extra; over the three-mile limit there is a charge of 20 cents for each mile or fraction thereof in excess of that distance. The innovation is already making heavy inroads on the business of the horse-drawn cabs, and the popularity of the taxicabs is increasing daily.

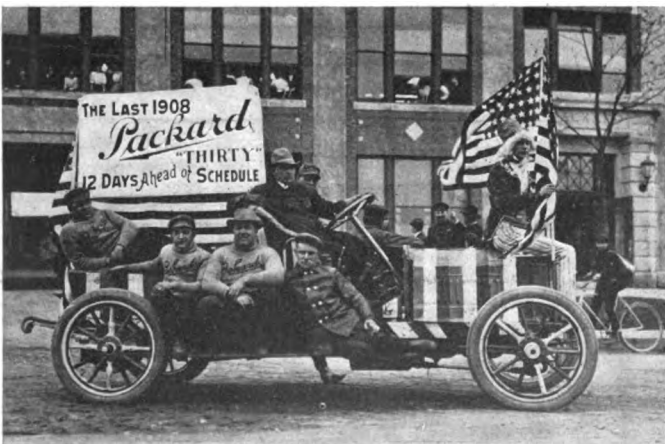

Packard Testers Celebrate Completion 1908 Output

When the last of the Packard 1908 cars were given their final test the testers celebrated the occasion and emphasized the fact that they had completed the year's output of 300 more cars than were made in 1907, twelve days ahead of schedule time.

### PICKED TO SUCCEED WALTER WHITE.

CLEVELAND, June 8.—Walter Rheineck, a slightly-built young lad scarcely out of his teens, is slated to step into the shoes of Walter White as a racing driver, according to the local White people. For some time past Rheineck has been traveling with White as his mechanic, and has thoroughly mastered the car. He has nerve in abundance, and it is thought will make an admirable driver. It is quite probable that he will be given his chance in the local hill climb June 13. Rheineck, up to about a year ago, was one of the star track athletes at Central high school, where he captained the track team. He has never been particularly strong, but is a bundle of grit and nerves.

### PREMIER 100-MILES-A-DAY PROGRESSES.

INDIANAPOLIS, IND., June 8.—The Premier Motor Manufacturing Company expects to run one of their four-cylinder models 10,000 miles by September 1. With the slogan "100 miles a day for 100 days" the car left Monument Place, in this city, last Monday morning. Joe Moore, one of the veteran Premier drivers, is driving, and prospective purchasers are acting as observers from day to day. The daily run is to be made despite weather conditions, and with no attempt to establish a speed record.

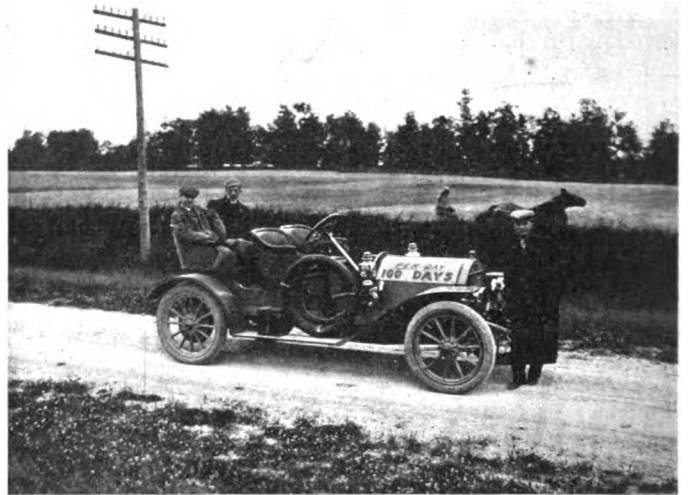

Premier Model 30 Century Car Starting 100 Days' Run

Last Monday the car, after being started by Chief of Police Robert Metzger, ran to Dublin to meet the Glidden Pathfinder, driven by Ray McNamara. On Thursday George Weidley and some friends rode in the car to the automobile show at Crawfordsville. The run is attracting much attention.

### NEW RELIANCE COMPANY BUYS OLD ONE.

Owosso, MICH., June 8.—The Reliance Motor Truck Company of Owosso has purchased at a receiver's sale the business and assets of the old Reliance Motor Truck Company of Detroit, and the business will be hereafter carried on in Owosso. The new company has been incorporated with a capital of \$250,000, of which \$150,000 has been subscribed and mostly paid in by local citizens. A manufacturing plant will at once be erected here. The officers of the company are: President, Fred O. Page, Detroit; vice-president, A. M. Bentley, Owosso; secretary and treasurer, W. F. Benkelman, Owosso.

### PICNIC AND PARADE OF OLDSMOBILISTS.

Gen. John J. Cutting will promote the third annual reunion of Oldsmobilists on June 20. It will embrace a parade and a picnic at the Columbia Oval Cricket Club grounds. Oldsmobile owners present with their cars will draw for the choice of an Oldsmobile \$3,000 palace touring car, or gentleman's roadster.

## BRIEF ITEMS OF NEWS AND TRADE MISCELLANY

The National Motor Vehicle Company, Indianapolis, Ind., has canceled its distributor's arrangements with the Ralph Temple Auto Company, Chicago, which has handled the line for several seasons. Other arrangements for representation have not yet been made.

Reports in regard to European racing events this season show that a long string of victories is being credited to cars with Continental tires. Included in the series is a race at the Brooklands track for 90-horsepower cars, in which D. Resta came in first with a 76-horsepower Mercedes in the phenomenal time of 93 miles an hour.

In making mention of the changes in the sales management of the Spare Motor Wheel of America, Ltd., in *THE AUTOMOBILE* last week, it was inadvertently stated that the sales department at 237 Michigan avenue, Chicago, was a branch house, while, as a matter of fact, this is the main office of the company. The factory is located at St. Anne, Ill.

Protests filed against E. Linn Mathewson, who won the Rocky Mountain Cup race with a Thomas-Detroit Forty, have been decided adversely by the official committee. The protest was based upon the claim that the Thomas-Detroit Forty *Blue Bird*, in which Mathewson won the race, was not a stock car. Mathewson immediately demanded that the car be examined by a committee of experts. The committee made a report in Mathewson's favor.

Consistent with the faultless performances of Pennsylvania tires in the most important racing events of this season was their triple victory at the Pimlico track races near Baltimore on Decoration Day. E. L. Leinbach, in a Stearns 60, equipped with Pennsylvania tires, not only won with ease the 100-mile championship event against one of the strongest fields ever entered, in 120 minutes 27 seconds, but also captured the Pimlico handicap from scratch as well as the 5-mile race for stock touring cars.

The Warner Instrument Company, of Beloit, Wis., manufacturers of the Warner Auto Meter, have presented the New York Automobile Dealers' Association with a beautiful silver challenge trophy, to be competed for in the Trade Association's bowling league this fall. The bowling league will consist of at least ten teams, and alleys at the corner of Thirty-fourth street and Broadway have been secured. It is the intention of the Warner Instrument Company to offer duplicates of this trophy for competition in Boston, Philadelphia, Chicago and elsewhere, among the various local automobile dealers' trade associations. The trophy is for a perpetual challenge game.

The Garage Equipment Company has moved its factory to Milwaukee, about ten thousand square feet of floor space having been secured for the manufacture of their line. A large quantity of new machinery has been installed, and, while the company is practically thirty days behind with orders at present, it is positive that within a few weeks it will have caught up with back orders. This company is just placing on the market a new horn valve, and is also making a valve of the same type, having a cut-out in connection. This can be used on any exhaust pipe, and a whistle or horn can be attached. It also has a muffler cut-out in it, making it a four-way valve.

One of the most striking features of the perfect score results of the 150-mile cross-country reliability run of the Indianapolis Automobile Dealers' Association was the performance of the Rapid sight-seeing 'bus with its load of twelve passengers. The car was primarily designed for use at comparatively low speeds and on well-paved streets of a city, so that compelling it to keep a schedule of 16 miles an hour over country roads with its full load up was something considerably out of the ordinary. It was driven by an eighteen-year-old boy, who, moreover, did not know much of the road, but succeeded in bringing the Rapid through with a clean score.

More than two thousand Rambler cars have been sold throughout the Western Hemisphere since the first of last November, and Thomas B. Jeffery & Company announce in the "Nineteen-Eight Success Number" of the *Rambler Magazine* that they have not, so far, received a single complaint nor have they had to replace a single broken part. This is perhaps one of the most remarkable records of performance in the history of the industry, when it is considered that 1908 Ramlers have, as the maker says, been delivered to nearly every State in the Union. It proves that the day of the standardized car of absolute reliability is rapidly drawing near. The sales of the Rambler began immediately after the New York shows, and although New England and the Eastern States have taken their share, the bulk of the output has gone into the Middle and Far Western States.

A party was being shown through the factory of the Ford Motor Company by Master Mechanic Wills, and as they went through the assembling department one of them asked how long it required to assemble a car. Calling the foreman, Mr. Wills instructed him to build a car from the ground up. The start was made at 4:30. One group of men assembled the frame, another got the wheels and tires, then the engine, the transmission and the differential were mounted, the radiator placed in position, the body bolted down, the coil placed, the oiler and gasoline tank filled and the car started. Time, 14 minutes. It was a convincing demonstration of the absolute uniformity and interchangeability of parts. The average time per car required to assemble these cars is less than this, as ten cars an hour are turned out every day, but this is done by building a quantity at a time, a set of men for each operation.

Few people realize the extent to which electrically driven automobiles for business and pleasure purposes are being used at the present time. In Chicago alone there are over one thousand electrics used for pleasure purposes, and in such cities as Cleveland, O., Rochester and Syracuse, N. Y., Denver, Col., and Indianapolis, Ind., the number of electrics is very large. The majority of these cars are cared for at garages, and, while the rates charged are not excessive, a considerable decrease is effected when the electric vehicle can be housed on the premises, it being not unusual for a victoria or stanhope to be maintained at a cost of not over \$15 per month, including charging and all repairs. In the majority of instances the current available is alternating, and before utilizing it for charging it is necessary that it be changed to a direct current. Recently a device known as a Mercury arc rectifier has been perfected. It is so simple that anyone can operate it, and

low in cost. The Studebaker Automobile Company, of South Bend, Ind., is selling a great many of these rectifiers in connection with their electric cars, and claim that this device will do much to increase the sale and use of electric vehicles.

The Times Square Automobile Company has just purchased a large number of 1908 Orient buckboards, which they are offering at special prices. Such transactions are not unusual in the automobile trade, and yet it calls to mind the possibilities for growth in this industry. Here is a firm that began in 1903 to deal in second-hand cars only, and only in a very moderate way. To-day they occupy a four-story building in West Forty-eighth street, 50 by 150, with a two-story "L" 40 by 160, facing at 1599 Broadway, New York City, that is stacked from basement to roof with cars, accessories and supplies of every description. In addition, the company's branch store at 1332 Michigan avenue, Chicago, is closely pressing the parent store in volume of business. The company is prepared to buy for spot cash any quantity of new or second-hand cars where price and quality suit them, and the volume of yearly business runs now into the millions. These results are not accidental, but are due to the energy, pluck and sound business methods of which the treasurer and general manager, Jesse Froehlich, is the chief exponent.

### PERSONAL TRADE MENTION.

Alexander Howell, who has been representing the Warner Instrument Company in New York City as chief salesman, has recently resigned his connection with that firm to accept a similar position with the Jones Speedometer Company. He will continue to have New York as his territory.

Albert C. Maucher, well known in Philadelphia automobilizing circles by reason of his many notable performances on track and road with the cars represented there by the Quaker City Automobile Company, has just been promoted to the superintendency of that concern.

H. N. Anderson, formerly with the Dayton Motor Car Company, Dayton, O., has just joined the engineering forces of the Speedwell Motor Car Company, of the same city. The latter concern now have a large new plant in course of construction, and its business is now growing very rapidly.

Claire L. Barnes, sales manager of the Detroit Steel Products Company, Detroit, Mich., has tendered his resignation, to take effect in the near future, and will become manager of sales for The Billings & Spencer Company, Hartford, Conn., one of the largest manufacturers of drop forgings, machinists' tools and special machinery in the country. Mr. Barnes has had charge of the sales department of the Detroit Steel Products Company since its organization.

Ernest L. Smith, who is well known throughout the automobile industry, having been connected with the Timken Roller Bearing Company for several years past, has just become identified with the Standard Roller Bearing Company as its western representative. The latter concern announces the installation of a thoroughly equipped laboratory at its factory in Philadelphia. It is in charge of Walter H. Hart, an expert chemist, formerly with the Alan Wood Iron & Steel Company.



## INFORMATION FOR AUTO USERS

**"Perfection" License Indicators.**—To comply with the numerous laws of the different States, the Automobile License Indicator Company, Lewisburg, Tenn., has brought out the device shown in the accompanying illustration. It is known as the "Perfection" license number indicator, and consists of a series of numerals, running from zero to nine, on each one of the five bands shown, while the sixth band at the right hand bears the State name or abbreviation, together with space for the number of the license issued by that State to the holder, as well as its legal speed limit. By loosening the thumb screw and turning the milled nuts at each end, any combination



OPERATING THE PERFECTION HANGER.

of figures up to 99,999 can be made, the type being 4 inches high by 1-2-inch face, while the ribbons of the indicator are made from a good quality opaque fabric which is non-stretchable and waterproof, although it is protected from the weather by a transparent celluloid covering. The same firm also makes the "Standard" license number indicator, which works on the card index system. Pockets take the place of ribbons, the five central ones containing celluloid or paraffine-coated cardboard cards, properly indexed and showing on their faces the ten numerals, zero to 9, while in the two end pockets are carried a series of cards bearing the State names. Changes of numbers and names are very simply and easily made.

**Burrowes Number Hanger.**—This device is one of several automobile specialties being placed on the market by the E. T. Burrowes Company, Portland, Me. The Burrowes number plate hanger is designed to be attached to the steering rod, axle or other convenient place, and the screw clamp draws it so tight that it cannot shake, rattle or wear the paint off the part to which it is fastened. Rattling is further prevented by a continuation of the strap, which forms a leather lining for the hook *F*. This hook is made of steel, and prevents the loss of the plate. The neat appearance of the hanger will be apparent from the accompanying illustration.



BURROWES ATTACHMENT.

**Hydro Pneumatic Springs.**—This is a device utilizing the combined resisting forces of air and oil, and is intended to take the place of the usual spring suspension. It consists of two cylinders, telescoping within one another. One of these holds a quantity of oil, while the second, or upper cylinder, contains an air chamber, in which the pressure may be regulated to suit the weight of the car. A clamp forming an extension of

the lower cylinder is attached directly to the axle of the car, while the upper cylinder is bolted to the frame. The two cylinders are kept in accurate alignment by means of a special guide working through an outside bearing. The device is extremely simple and very effective in action. At first the oil absorbs more or less of the air and a little of the pressure is lost, but after this has been restored by a few strokes of the pump the device will give good service for the entire season without further attention. At the end of the season's running it is merely necessary to replace the oil, as it tends to gum in combination with the air.

**Running Board Sets.**—In order to provide greater comfort on the small Ford, Maxwell, Reo and single cylinder Cadillac runabouts, the Jenkins Specialty Manufacturing Company, Sumter, S. C., has brought out sets of running boards designed to fit these various small cars. They are made of the best grade seasoned poplar, which is noted for its light weight and strength. After careful seasoning, they are painted all over to keep out moisture, and are then covered with the best grade of Goodrich rubber in red or gray, and are finished with attractive brass binding specially designed for this purpose. The supports are made of pressed steel in attractive designs.



SPECIAL RUNNING BOARDS FOR RUNABOUTS.

The same firm also makes a line of slip covers in linen or khaki, for the same cars, as well as chain boots of leather, hoods, mud splashes, under pans of hard fiber and the like.

**Brown Four-cycle Compressometer.**—This is a handy little instrument made by The Brown Company, Syracuse, N. Y., and is designed to enable the compression of a motor cylinder to be obtained very simply and conveniently. It is a matter of common knowledge that loss of compression is one of the most frequent causes of lost power, and the use of the Compressometer will readily show exactly which cylinder is at fault. It is particularly essential that the compression of the various cylinders of a multi-cylinder motor should be uniform, and the Compressometer offers a ready means of determining this. It is only necessary to screw it into the cylinder in place of the spark plug, turning the motor over by hand, when the gauge, which is calibrated in pounds per square inch, will immediately show the pressure. But the motor should not be run with the instrument in place. The reading of the maximum hand with which the instrument is equipped

will show how high the pointer goes without the necessity of watching it. The Compressometer is equally valuable for marine use, as it can be employed to test the vacuum in the crankcase of a two-cycle motor, thus readily detecting crankcase leaks. The Brown Company having just brought out a special combination instrument for this purpose. The crankcase vacuum and pressure are taken from the base by a 1-8-inch nipple, while by inserting it in the cylinder head in the usual manner the maximum compression is registered.

**Shaler Electric Vulcanizers.**—There is nothing to which the old adage about the stitch in time applies with so much force as to repairs to pneumatic tires. By promptly repairing all cuts and holes,

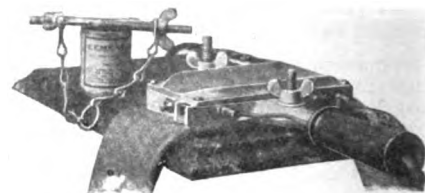

SHALER ELECTRIC VULCANIZER IN USE.

a set of tires may not only be made to last twice as long, but will be in a dependable condition throughout their life of service. To make it possible to do this, the C. A. Shaler Company, Wau-pun, Wis., manufacture a handy electric vulcanizer, which is simplicity itself and may be used by the autoist or garageman without any previous experience in the repairing of pneumatic tires as the makers supply explicit directions as well as the necessary materials. There is no risk of injuring the tire, as the heat may be positively controlled so that the vulcanizer requires but a minimum of attention and does not need to be watched.

**Coates Auto Buffing Outfits.**—There has been a demand for a power-driven buffing outfit for keeping the bright work on a car clean, and while the electric type manufactured by the Coates Clipper Manufacturing Company, Worcester, Mass., has met with tremendous sale, the expense where alternating current was used was sometimes prohibitive. To overcome this, the same makers have just put a friction-driven outfit on the market. It is run by friction from the rear wheel, the latter being raised by a jack, while the roller is held in position by a patented device designed for the purpose. To save the expense of a long flexible shaft, a jointed rod is supplied for the greater part of the drive, the remainder being through a Coates patent flexible shaft.

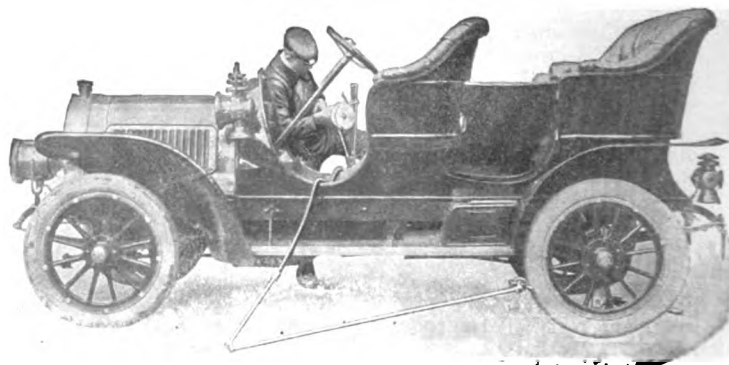

HOW THE COATES AUTO BUFFING OUTFITS ARE EMPLOYED FOR POLISHING.

# THE AUTOMOBILE

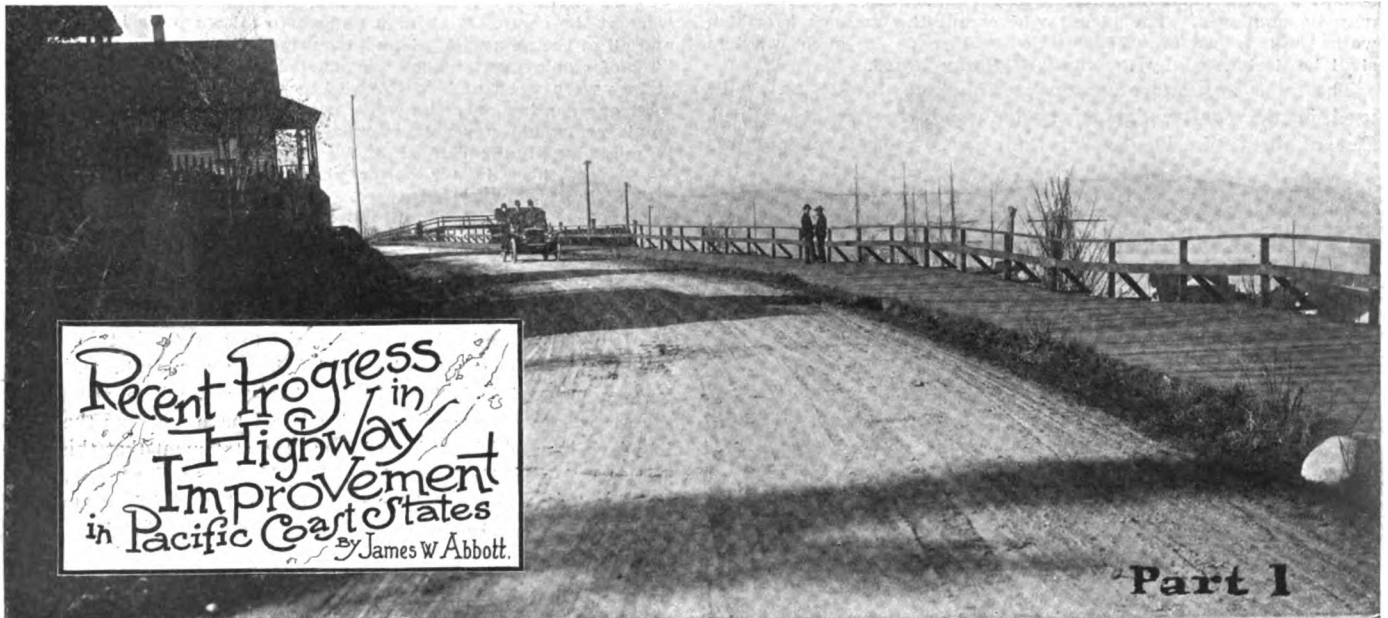

One of the Improved Highways in Whatcom County, in the Northernmost Part of the State of Washington.

**TO MY COMRADES IN THE GOOD ROADS CAUSE:**

The enthusiasm with which I worked with you and for you during the years that I was in the Government Highway Service has not been quenched through disuse. The need is still as insistent and the cause as worthy as it was while I was actively working.



James W. Abbott.

There is no shade of question in my mind that through the automobile is coming the success which is going to crown all the efforts of those laborious years.

I believe that if every man who owns an automobile in the United States and who prays to God for better roads to drive it over, would assist insofar as he might in the work for good roads the result would be effective beyond any of our comprehensions.

It has been with the earnest wish to add my mite to this effort that I have taken from my work time which I could

ill afford to give to prepare this series of articles. It has been a labor of love for the cause I love in the hope that some good might come of it. Most cordially yours,

*James W. Abbott*  
 Ploche, Nev.,  
 June 1, 1908.

**D**URING the years in which I represented the United States Government in its work for highway betterment throughout this region, I centered my efforts upon two plans which I believed would be the most effective in securing the desired results.

The first of these was to get instituted generally in all the counties of these Pacific Coast States practical methods of utilizing the activities of convicts in road construction. The second was to arouse a public sentiment which should finally recognize the importance of a first-class highway, leading from British Columbia to Mexico, approximately parallel to the coast line.

The argument for the use of the convict in road construction may be briefly stated as follows: We restrain the criminal of his liberty for the benefit of society. To obtain enduring, beneficial results, our penal methods must be corrective rather than punitive. The fear of an avenging law is an influence of minor importance in deterring crime. The strongest impulse for good conduct is good character. Moderate, healthful exercise of body and diversion of mind will prevent the normally good citizen whom mischance has brought within prison walls from lapsing into a criminal, while it will restore normal health to many perverted natures.

The building of public works which could not otherwise be undertaken is the sole occupation in which convicts can be employed which will not only not encroach upon free labor, but which will actually immeasurably increase the demand for the services of free labor, benefiting at the same time the criminal and the free man, and tending to an elevation of moral standard throughout the community.

No influence more destructive upon character can be imagined than enforced idleness; while to allow the activity of the convict to be employed in making products for sale at prices below the normal market is degrading to American labor.

There is no character of public improvement of such general importance to all the people as making improved highways. The activities of our convicts throughout the country constitute in the aggregate an enormous force, and I believe that one of the most vital problems of our civilization lies in solving the question of how to use these activities most effectively in constructing highways.

I made an exhaustive study of every method attempted along this line in the United States. In Washington and Oregon I

centered my efforts to get policies adopted which should more and more, as time went on, employ these activities for the construction of highways. My recent visit to Washington and Oregon was the first which I had made in somewhat over two years, and I was overwhelmingly astounded and gratified at the progress which has been made in those States during that period.

Upon the 9th of March, 1907, the following legislative enactment became the law in Washington:

All convicts confined and not otherwise employed shall be employed under authority of the State Board of Control, in charge of the superintendent of the penitentiary, or of such other persons in the employ of the State as the State Board of Control shall direct, in the building of State roads in this State. All expense of whatever nature incurred through such employment shall be paid from the fund appropriated by the State legislature for the construction of the particular road or roads upon which such convicts may be employed. The places where and the manner in which work shall be performed upon the said roads by such convicts shall be designated by the State Highway Board.

The same Legislature appropriated the sum of \$225,000 to be used in the construction of twelve roads specifically defined. One of the roads thus provided for in Okanogan county was



Convict Camp at Kelly Butte Stockade, Oregon.

selected for making the first experiment with convicts under the law above quoted. The unqualified success of this experiment in all ways is calculated, in my judgment, to lead to results for road betterment more far-reaching than any other enactment ever placed upon the statute books of this nation.

The report of Joseph M. Snow, highway commissioner of Washington, recently issued, shows that the average value of the daily work of a convict on this road was \$4.03, measured by the bids of contractors before it was definitely decided to use convict labor. Being the first experiment of its kind, the methods and system employed were necessarily tentative, and Mr. Snow says in his report: "With the experience gained, the expense of carrying on this class of work can be materially reduced in the future." He had already figured, charging up all expense of outfit, transportation, supplies, salaries, and engineering to the road fund, that the convict work represented a profit of about 58 per cent. over the bids submitted.

The closing page of his report is, to my mind, the most cheering message to the good roads advocates of the United States which ever has been or ever could be written by any man. It shows earnestness and enthusiasm, and is as follows:

The financial benefit to the public I have shown; and referring to the reformatory influence on the prisoners, it may be said that a glance at the men who have been employed at State Camp No. 1 shows them hale, hearty and well contented, and shows that they have lost the peculiar appearance that comes from confinement in the jail or penitentiary. The camp has been kept in excellent, satisfactory condition. No cases of sickness have occurred, and but one slight accident whereby a man slipped from the face of a bluff and fractured his ankle. Three men were paroled during the season for good conduct, and this had an excellent effect on those remaining. The men who were furnished for this work were not those noted at the penitentiary for a desire to work, but under the exceptional management of George F. Charlot, who has acted as chief guard and superintendent of construction, the men were encouraged to change their methods and developed into a first-class crew of workmen. They worked regularly eight hours each day, losing only two quarter-days on account of inclement weather or other causes during the three months and a half they were at the camp. Each man seemed to take a pride in the work, and all of the men with whom I conversed desired to remain in this kind of employment. They are trusted to such an extent that no stripes were worn and no irons of any description were used. In fact, one passing over the work, not knowing the character of the employes, would never have known that it was a convict crew. It might safely be said that the men employed at State Camp No. 1 left there in far better physical, mental and moral condition than they arrived there. The success of the proposition having been so satisfactorily demonstrated, it is now proposed to place a larger crew on State Road No. 7, known as the Snoqualmie Pass Road, in the early spring.

With reference to the character of the work, Mr. Snow says: "The cuts in solid rock run from twelve to forty-five feet in depth, and the embankment from six to twenty feet in width, the maximum grade on the road being 4 per cent., while the greater part of it is level." The half-tones which accompany the report are very realistic, and, while I have not seen the road, I believe it would be safe to hazard the statement that this road and the Scenic Highway from Las Vegas to Santa Fe, New Mexico, both constructed by convicts, reach the highest standard of mountain road construction ever attempted in the United States.

#### What Has Been Done in the State of Oregon.

In the State of Oregon, Judge Lionel R. Webster, the county judge of Multnomah county, in which Portland is situated, was always my most effective collaborator for the use of convicts in road building. In season and out of season, for years, Judge Webster fought for the adoption of this policy. In that State all highway matters come under the control of the county judge, and in many respects it has proved to be a very wise plan. County judges, as a rule, are men of high intelligence and keen discernment. They seek the welfare of their constituents, and are earnest in their endeavors to promote the welfare of the counties over whose courts they preside. No higher type of reformer has been raised up by Providence in this country than Judge Webster. He could direct only the employment of the convicts sentenced in his own court, but began years ago with these to evolve a feasible system for utilizing their activities in improving the roads adjacent to the city of Portland.

The first time I went with Judge Webster to see what his convicts were doing, I found them in a crude stockade, breaking rock by hand. It was a poor quality of rock, and, of course, progress was slow and unsatisfactory. But Judge Webster kept at it, and added to the highway system in that county considerable mileage of first-class macadam roads. He labored at Salem with the Governor and with the Legislature, but Oregon Legislatures are not as enlightened as Washington Legislatures, and they are slower to appreciate the importance of the highway question generally.

The State of Washington had, to lead its movement for highway improvement, a great man with unlimited wealth and influence, Samuel Hill of Seattle, the first and only president of the Washington Good Roads Association. He was elected at a convention called by himself in Seattle in October, 1902. Since that time Mr. Hill has devoted his superior talents, indefatigable energies and extraordinary personality to effecting the emancipation of that State from the bondage of bad roads. He has

spared neither time nor money. He secured from the Government that genial good roads enthusiast, Sam C. Lancaster, to come to Washington and engage in a campaign of proselyting. Through his influence, Sam Lancaster has been installed in a permanent chair in the University of Washington, at Seattle, where his sole duties are to teach the students technical methods of road construction. Sam Hill and Sam Lancaster went up and down the State of Washington, preaching the gospel of good roads until they had it fairly set on fire, and out of that campaign came the enlightened legislation which I have previously alluded to.

Judge Webster had little of such aid. The State of Oregon possesses no Sam Hill. No other State in the Union possesses a Sam Hill. It is one hope in which I have indulged for years that there might be other Sam Hills rise up in due time to serve their country as he has served it.

Politics and roads never have closely coalesced, and Oregon has thus far proved no exception to the rule. But Judge Webster, by the irresistible force of his earnest character and energetic temperament, has gone forward in the good work. It was to me a most affecting privilege which I enjoyed when I visited the rock quarries at Kelly Butte, seven miles from the county courthouse in Portland. This is the name of an enor-

mous intrusive dike of first-class rock for road-making purposes.

I found at Kelly Butte stockade, bunk houses, messrooms and kitchen, and a complete plant operated by steam power for crushing rock. I found every convict of Multnomah county working industriously, happily and effectively. I found that this rock was being put into condition for making macadam roads and delivered automatically to wagons at a maximum cost of 27 cents a cubic yard, while the entire cost of producing this result was little less than would have been the cost of maintaining and guarding these convicts in idleness. In other words, I found that Judge Webster was producing material for first-class macadam roads practically without cost. The result is the highways leading out from the city of Portland average better than the highways leading out from any other large metropolis on this coast, or it may be west of the Mississippi.

Judge Webster's zeal will not flag nor his efforts be abated. If he lives, it is absolutely certain that, with this plant at Kelly Butte for an object lesson, he will show the people of Oregon the way to most effectively develop their resources. When the people clearly see any great need, they get it. The political puppets in that State will be swept from the stage as a man would sweep a chessboard, and in their place will come men ready and willing to heed the voice of the people.

## GOOD ROADS AGITATION IN CENTRAL MASSACHUSETTS

SPRINGFIELD, MASS., June 15.—So far the auto season cannot be said to be on in this vicinity to any great extent, but its rapid approach can be foretold to a certain extent by the good roads agitation that is uppermost at present. Because it is feared that a two-mile stretch of very bad road in Becket known on the Springfield side as Mowrey's hill and Jacob's Ladder on the Berkshire side, will drive automobilists off that route, action has been taken by a special committee of two hotel men from this city and a representative of the Springfield Automobile Club toward raising funds for temporary repairs. Already \$500 has been pledged by hotel men along the route between this city and the Berkshires for the work, which it is estimated will cost about \$720, and it is probable that the Automobile Club in this city will raise the rest of the money. The bad strip of road begins at the Bonnyrigg Four Corners and extends as far as Jacob's Ladder, and has been rendered treacherous and hard of travel because of huge boulders and earth washed down from the mountains by the Spring rains. These repairs will be made pending the building of a State road along this route, a bill for which has been passed in the legislature to take effect next year.

Another action taken by the local club for the benefit of autoists passing this way, was the selecting of a new route to the eastward to take the place of the new State road between

Palmer and Warren, now in process of construction. The necessary signs have been posted showing the new road to be as follows: By way of the Boston road to the Five Mile Pond school house, to Parker street, to Ludlow, to Red Ridge, to Three Rivers, to Palmer, to Brimfield and Brookfield. It is figured that it will be along the middle of July before the State road is completed, but this route will be subject to change as the road progresses.

The local club has been asked by the Hartford Automobile Club to join it in an attempt to get general road improvement between that city and this. The condition of this road has been much criticised and is so bad in some places, mostly in Connecticut, that autoists are being warned away from it and are taking to the shore line on their trips between New York and Boston. The Springfield club, however, has not taken the matter up because, with the exception of a stretch of road three-quarters of a mile long near Longmeadow, the roads this side of the State line are in excellent condition. The strip mentioned as an exception is not so very bad or so very good and will be improved in the very near future. President Mark Aitken, of the local club, expressed the opinion that the State of Massachusetts had done its part as regards the roads in this section and that the club believed it was up to the state of Connecticut to see that its roads were of a character to encourage touring.

## AMERICAN COMMISSION TO INTERNATIONAL ROAD CONGRESS

WASHINGTON, D. C., June 15.—President Roosevelt has directed that this nation be strongly and officially represented at the International Road Congress to be held at Paris the week beginning October 11, and credentials have been issued naming Logan Waller Page, Director of the Office of Public Roads of the U. S. Department of Agriculture, Chairman of the Commission. The other members named are Colonel Charles S. Bromwell of the United States Corps of Engineers, now serving as Superintendent of Buildings and Grounds of the District of Columbia, and Clifford Richardson of New York, an eminent chemist and one of the world's acknowledged authorities on bituminous road building materials.

This coming Congress, which will be attended by distin-

guished delegates from every country in the world, is regarded by highway engineers and experts as probably the most important ever summoned for the discussion of an economic question. Its need is the direct outgrowth of the advent of the automobile.

Invitations have been transmitted through the office of public roads to State highway commissioners, city engineers and park commissioners to attend the Congress, and already a large number of delegates have been selected. It is confidently anticipated that this will be but the opening gun of a universal movement for good roads due to the possibilities of their extended use on long runs by means of the automobile, and the presence of an American delegation is certainly an encouraging sign.



## ENGLISH CAR DRAWS GRAND PRIX STARTING HONOR

PARIS, June 10.—England drew the lucky number at the Automobile Club of France, thus allowing one of the Austin cars to start first in the Grand Prix on the Dieppe circuit July 7. After the Englishman the first of the Mercedes cars will rush away over the triangle by the seashore, and will be followed by others at intervals of one minute, in the order: Motobloc, Renault, Dietrich, Benz, Fiat, Brasier, Porthos, Opel, Bayard-Clément, Itala, Weigel, Mors. Thomas, with Lewis Strang at the wheel, Panhard, and Germain.

This will end the first series; the second series will be formed by number two car from each of the firms mentioned with the exception that Thomas, having but one car, the second Mors will be followed by a Panhard. The same applies to the third series. Lewis Strang, who came down to the library of the Automobile Club of France in company with Harry S. Houpt and Montague Roberts, found that his usual good luck deserted him, for the ball that he drew out of the bag and handed to Chairman Rene de Knyff bore the starting number fifteen.

Almost at the last minute, Emile Mors came into the A. C. F. clubhouse and handed over \$4,800 in payment of double entrance fees for his three Mors cars. Rochet-Schneider, who was looked upon as an eleventh-hour entrant, failed to come forward with the necessary cash. Total entries for the Grand Prix race thus stand 49, of which 24 are French, 9 German, 6 Italian, 6 English, 3 Belgian and one American. For the voiturette race to be run over the same course the preceding day there are now 65 cars, all of them French with the exception of the Isotta-Fraschini and Martini teams. A Delage car will be the first to start in this event. The number of entries constitutes a record, the total being greater than has ever been gathered together for any speed event, and the Grand Prix cars alone being superior in number to those of any previous big race held in Europe.

Since landing at Havre from the cross Channel steamer from Southampton, the American team for the Grand Prix has not wasted its time. Training quarters having been secured at the Grand Hotel, Dieppe, and close acquaintance was made with the course by means of the touring car. Although geared far too low for the fast French roads, the Thomas Flyer swept over the 47 miles of perfect macadam in so much under the hour that Strang would certainly have difficulty in pleading "Not guilty" to a charge of exceeding the French speed limit.

Various formalities having to be accomplished in Paris, the entire team ran down from the seashore to the capital last Sunday, a French Protos racer, with Emile Stricker at the

wheel, going ahead to show the way, Strang following on the rearing Thomas, and the rest of the team packed, together with their baggage, in the touring car which Knipper took care of.

The Prothos, which claims to have something like 120 horsepower within its six cylinders, set a merry pace that Strang had no difficulty in duplicating. Knipper was shaken off on every stretch of open road, but in the villages, where the racers had to cut down to a noisy crawl on account of the Sunday merrymakers, the touring car with its fluttering American flag was always able to run close up.

French government officials have no cognizance of New York-Paris runs, Brighton Beach twenty-four-hour and other records, and before Montague Roberts could get behind the wheel of a Thomas touring car he had to take an inspector for a five-mile run through Paris. The report of the inspector was that he guessed "Monty" was fit to drive any type of automobile and a first-class permit was issued on the spot.

The cylinder bores of the racer having been verified and stamped and spare cylinders treated in a similar manner, the racing car and full team will return to Dieppe and make such further road tests as are necessary in the neighborhood of the circuit. Racing cars are not allowed on the course, so that most of the driver's training will have to be done with the touring car. It is practically certain that the course will be opened for official trials a few days before the race, but the period is not likely to extend over four or five days, and will be limited to two or three hours each morning. In this respect all foreign cars are at a disadvantage, the club being obliged to close the roads to racers a couple of months before the event in order to allow the bad spots to be remade and the whole surface to be tamped. There are at present portions that have been dug up by anti-skid tires, but all such spots are being entirely relaid and the tarring apparatus will provide 47 miles of highway absolutely dustless. Already the greater portion of this work has been accomplished.

Work on the grandstands and gasoline stations is in an advanced condition. The entire ground at the starting line has been marked out, the big trench running the entire front of the grandstand has been dug out, and the tunnel connecting the outside with the inside of the circuit has already been pierced. The foundations of all the buildings are laid, and everything is so advanced that there should not be any eleventh-hour hustling. In some of the villages stout barricades are already erected; in the open country light fencing is lying in readiness to be put up.

### RULES PUBLISHED FOR CIRCUIT DES ARDENNES.

BRUSSELS, June 3.—The sports committee of the Automobile Club of Belgium has issued the rules and regulations for Belgium's two most important races for the season—the Circuit des Ardennes and the touring car race for the Liedekerke cup. Both events are scheduled to be run August 12, the former over a course of 600 kilometers and the latter over the same circuit, but the distance to be only 400 kilometers. For some time it has been said that the old Ardennes circuit would be used, the one including on its route the following towns and villages: Bastogne, starting and finishing place; Longlier, Offaing, Leglise, Anlier, Habay-la-Neuve, Corne du Bois des Pendus, Martelange and Bastogne. A visit at the Automobile Club of Belgium headquarters this afternoon, however, brought out the fact that Baron de Crawhez is in the Ardennes district trying to discover some new roads. There will not be much of an entry list by Belgian manufacturers, owing to the great efforts made for Belgian representation in the Grand Prix next month, but most of them probably will nominate cars for the touring car event.

### COUPE DE LA PRESSE POSTPONED TILL 1909.

PARIS, June 10.—Constructors having failed to respond in sufficient numbers to the invitation to take part in a fuel consumption race on the Dieppe circuit next August, the Automobile Club of France has officially announced that its Coupe de la Presse is postponed until 1909. In reality the event is definitely abandoned, for it is doubtful if the competition will be held even in 1909. This abandonment deprives France of the only event for stock touring cars this year, the Coupe de la Presse being designed for stock chassis stripped under certain restrictions, and competing for speed with a limited amount of gasoline. All the interest of the year centers around speed tests, touring competitions in which there are as many winners as classes failing to solicit interest.

Germany intends to be well represented in the Florio Cup race at Bologna, Italy, September 6. The Mercedes, Opel, and Benz have entered teams of three cars each, while it is thought likely other German makers will come in later.



How the Cars Lined Up on Philadelphia's Historic Race Course Ready for the 50-mile Free-for-All.

PHILADELPHIA, June 15.—It was Autocar day at Point Breeze track Saturday, when the Quaker City Motor Club held its annual spring meet. The Ardmore-built car not only captured first place and the cup in the big smoke event—the free-for-all—but took second honors as well, and this despite the fact that its 28-horsepower was pitted against the 40's 50's and even 70's of some of the most powerful American cars on the market. It was a case of heavy driving of moderate-powered cars winning over the tire-punishing rushes of much more powerful machines on a track which turns tricky to a degree and requiring nursing even under such favorable conditions as obtained last Saturday.

Fourteen cars faced Starter Fred Wagner in the big race, and the track was so narrow that two lines were necessary—ten in front and four in the rear. In the awful roar of the exhausts, the crack of the gun was hardly audible, but the cars were sent away to a good start, despite the much-too-close line-up. The first car to show out of the cloud of smoke and dust which followed the contestants around the first turn was the Pullman "40," driven by "Bob" Morton, the hero of last winter's Philadelphia-Savannah race. In the first mile he opened up a gap of 100 yards on the bunch. But the big American "50," with Wally Owen at the wheel, soon came out of the ruck and set sail for the leader. Slowly but surely "Wally" closed up on "Bob," and shortly after the completion of the eighth lap went to the front with a burst of speed which set the crowd wild.

Had Owen been content to maintain a small lead till the close of the race he might have won; but he made the mistake of trying to lap his pursuers, not once, but twice, and again. This brought about his undoing, for after holding the lead for 25 miles, the grinding on the turns put one of his tires to the bad, and on the next lap he ran into the infield for repairs. Morton lost no time in moving to the front; but once there, he made the same mistake as "Wally"—he opened up wide and attempted to put miles of daylight between his Pullman and the oncoming bunch. But the turns got him, too, before long, and on the 29th lap the York-built car went into quarantine with a deflated tire.

Meantime the two Autocar "28's," driven by E. F. Frease and J. F. Brown at a moderate gait—a trifle under 1:20—had made

up a 1:1-2-mile default and swung into the lead amid a roar from the crowd of 7,000 which hugely enjoyed the performance of the local cars and immediately began to root for a victory. The big Thomas "70" of Charley Howard, which earlier in the day had made the fastest time of the meet, but which had lost time through tire trouble, then challenged the Autocar duo, but the increased speed soon resulted in more work for the medicine men in the infield, and it lost its opportunity.

The only cars that now had a chance against the Autocars—and that only in the event of a breakdown of the latter—were Frank Yerger's stripped Studebaker "30" (the self-same car that was beaten in the duel with Morton's Pullman in that slimy race to Savannah) and the 35-horsepower Mitchell, driven by William Freitag. But neither of the latter had the speed to more than hold the Autocars even, and the latter kept on the even tenor of their way reeling off 1:20 miles. By the time the big fellows swung out again in pursuit their lead was too big to be overcome in the short distance yet to be covered, and the Ardmoreites registered a one-two victory in rather hollow style in the slow time of 1:06:51.

The fastest race of the day was the 10-mile event for stock chassis listed at \$4,001 or over. It was a ding-dong affair between Howard's big Thomas and Wally Owen's American. Each car was in the lead several times, but on the last lap the Thomas went out in front, and lasted to the tape, although the American was beaten out but by the narrow margin of two-fifths of a second—the only nose finish of the day.

Although unsuccessful in the big race, "Bob" Morton scored in both the \$2,001 to \$3,000 stock chassis races—at 5 and 10 miles—beating out a brother Pullmanite, C. B. Kirkham and Jack Harkin's Thomas-Detroit "40" in the short event, and again Kirkham and J. F. Brown's Autocar in the ten mile. One-two twice for the Pullman should have satisfied almost anybody, but Manager "Lee" French, of the local agency, was heartbroken over Morton's bad luck in the big race.

Counting the fact that it made the fastest time in the mile trials, the Pennsylvania "50," driven by Len Zengle, was also a double winner. It beat out A. G. Van Tine's Garford "40" in a



Winning Autocar that Captured the 50-mile Free-for-All.

special five-mile match race and in the trials did a 1:10 mile, beating out the Thomas Flyer, the Garford and the Jackson.

"Pop" Parkin entered his just completed "Big Joe" in the free-for-all, but experienced trouble from the start. He kept pluckily at work, however, and the car was running at the finish gun, although miles behind the winner.

In a special race for Autocars, John Archfield beat out the winning and place cars in the free-for-all, sweeping under the wire in 4:00 flat.

William Freitag's Mitchell "35" easily disposed of the 24-horsepower Maxwell, driven by William David, in the five-mile race for gasoline stock touring cars listed at between \$1,251 and \$2,000. The summary:

ONE MILE—GASOLINE STOCK RUNABOUTS, \$850 OR UNDER.

- 1. Buick .....18 Edward Wilkie .....1:34
- 2. Ford .....18 J. F. Graham.....1:37 3-5
- 3. Maxwell .....14 W. M. David .....1:44 2-5

THREE MILES—GASOLINE STOCK RUNABOUTS, TOURABOUTS, TOURING CARS, TOURING RUNABOUTS, \$851 TO \$1,250.

- 1. Buick .....18 Edward Wilkie .....4:24 1-5
- 2. Mitchell .....20 William Freitag .....5:01 1-5

FIVE MILES—GASOLINE STOCK CHASSIS; COMPLETED CAR LISTED AT \$2,001 TO \$3,000.

- 1. Pullman .....40 Robert Morton .....6:17
- 2. Pullman .....33 C. B. Kirkham.....
- 3. Thomas-Detroit.....40 Jack Harkins.....

FIVE MILES—GASOLINE STOCK TOURING CARS, \$1,251 TO \$2,000.

- 1. Mitchell .....35 W. Freitag .....7:21
- 2. Maxwell .....24 Wm. David.....

FIVE MILES—SPECIAL MATCH RACE, STOCK CARS.

- 1. Pennsylvania .....50 Len Zengle .....6:27
- 2. Garford .....40 C. A. G. Van Tine.....

TEN MILES—GASOLINE STOCK CHASSIS, COMPLETED CAR LISTED AT \$2,001 TO \$3,000.

- 1. Pullman .....40 Robert Morton.....12:27 3-5
- 2. Pullman .....33 C.B. Kirkham.....
- 3. Autocar .....28 J. F. Brown.....

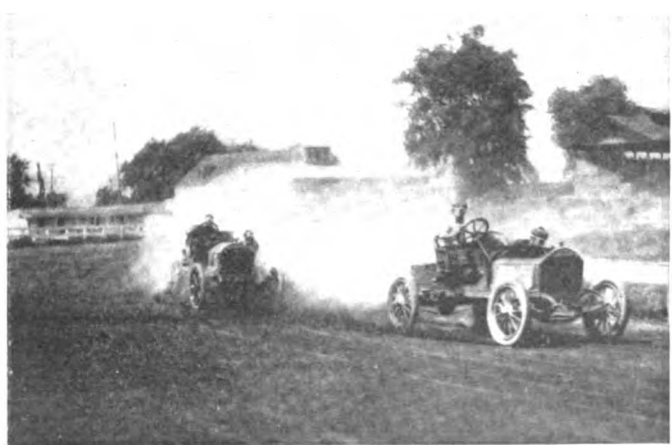

Morton in Pullman Winning Five-mile Stock Car Class.

TEN MILES—GASOLINE STOCK CHASSIS, COMPLETED CAR LISTED AT \$4,001 OR OVER.

- 1. Thomas Flyer .....70 Charles Howard .....12:00 2-5
- 2. American .....50 Wally Owen .....12:00 4-5

FIFTY MILES—FREE-FOR-ALL.

- 1. Autocar .....28 E. H. Frease .....1:06:51
- 2. Autocar .....28 J. F. Brown.....
- 3. Studebaker .....30 F. H. Yerger.....
- 4. American .....50 Wally Owen.....
- 5. Mitchell .....35 Wm. Freitag.....

TIME TRIALS—ONE MILE.

- 1. Pennsylvania .....50 Len Zengle .....1:10
- 2. Thomas Flyer .....70 Charles Howard .....1:16
- 3. Garford .....40 A. G. Van Tine.....1:18
- 4. Jackson .....30 J. Robinson.....1:27

THREE MILES—SPECIAL FOR AUTOCARS ONLY.

- 1. Autocar .....28 John Archfield .....4:00
- 2. Autocar .....28 J. F. Brown.....
- 3. Autocar .....28 E. H. Frease.....

CHICAGO MOTOR CLUB'S 1,000-MILE TEST.

CHICAGO, June 15.—Final surveys of the four routes that will be used in the Chicago Motor Club's 1,000-mile reliability run June 24-27, show that the contesting cars will be required to travel 1,014.2 miles, divided, into daily trips of 267.7, 243.9, 258.1 and 229.5 miles. In making these trips the cars will pass through a territory which is regarded as a fruitful selling field, it being peopled by rich farmers who are becoming interested in motor cars. The roads are reported to be above the ordinary, except, of course, there are a few bad stretches which will test out the cars.

First day, June 24.—The cars will be sent on a trip to the north into Wisconsin, going through Highland Park, Lake Forest, North Chicago, Waukegan, Zion City, Kenosha, Lake Geneva, Delavan, Emerald Grove, Janesville, Wis., Beloit, Rockford, Ill., Rochelle, De Kalb, St. Charles, West Chicago, Lombard, Elmhurst and back to Chicago. The total distance for this leg of the run is 262.7 miles, with checking stations at Kenosha, Janesville and Rochelle. This route was mapped out by O. G. Temme and T. T. Roe in a White steamer.

Second day, June 25.—The cars go west, hitting Elmhurst, Lombard, Glen Ellyn, Naperville, Aurora, Big Rock, Little Rock, Somonauk, Wedron, Ottawa, Lowell, Tonica, La Salle, Earlville, Leland, Somonauk again, Sandwich, Yorkville, Aurora, Downers Grove and Lyons, the mileage being 243.9, according to the odometer reading of the Dorris, driven by Charles P. Root. The checking stations will be at Aurora, La Salle, Ottawa and a second time at Aurora.

Third day, June 26.—Cars will follow the route marked by Harry P. Branstetter in a Wayne roadster, a journey of 258.1 miles in length, which goes into Indiana by way of the Halsted street route, touching Riverdale, Oak Glen, Munster, St. Johns, Crown Point, Merrillville, Valparaiso, La Porte, Tea Garden, La Paz, Plymouth, Lakeville, South Bend, New Carlisle, Rolling Prairie, Michigan City, Burdick, Chesterton, Porter, Hobart, Highands, Hammond and South Chicago. The checking stations will be at La Porte, Plymouth, South Bend and Michigan City.

Fourth day, June 27.—The scene shifts again to the west, following a trail brazed by C. A. Tilt and F. H. Trego in a Diamond T roadster, the distance being 229.5 miles, and passing through Addison, Bloomingdale, Ontarioville, Elgin, Huntley, Marengo, Belvidere, Cherry Valley, Rockford, Byron, Oregon, Honey Creek, Chano, Kings, Rochelle, Steward, Shabbona, Waterman, Hinkley, Big Rock, Aurora, Downers Grove and Lyons. The checking stations will be at Elgin, Rockford, Rochelle and Aurora.

A MILLIONAIRE MEET AT LONG BRANCH.

Prominent Long Branch summer residents, whose names for the most part are conspicuous in the motor car fraternity, have formed the Elkwood Park Automobile Association, and will run a race meet at the old mile circuit, whereon in earlier days of the sport similar contests were held on Fourth of July.

The officers of the new association are: President, Hon. Charles C. McFadden, Mayor of Long Branch; vice-president, Robert Guggenheim; treasurer, William B. Anderson; secretary, T. Francis Moore; governors, Fred Lewisohn, Harry Payne Whitney, W. E. D. Stokes, P. J. Casey, Walter Lewisohn, Martin H. Vogel, and Col. T. J. O'Donahue.

The program is as follows: 100 miles for Guggenheim \$250 trophy; 50 miles free-for-all for Lewisohn \$200 cup; 10 miles for amateurs under A. A. A. rules; 5 miles pick-up race for fully equipped touring cars to stop and pick up a passenger each mile; time trials against circular track records.

## CHADWICK SCORES AGAIN AT CLEVELAND CLIMB

CLEVELAND, June 15.—Following its victories at other important events of the kind, the Chadwick has invaded the home city of what are reputed to be the fastest hill-climbing cars in the world, the White and the Stearns, and carried off the honors in the Cleveland Automobile Club's annual hill-climb, but through an unfortunate combination of circumstances there was practically no competition for the winner in its own class, Walter White still being in the hospital and the Stearns interests not entering any of their cars, in conformity with their policy of only being represented by amateur-owned machines. However, the Stoddard-Dayton, of far less power, proved itself a formidable rival to the big six-cylinder champion and pushed the latter's times very closely. In fact, the smaller car's performance, and the driving of Mrs. Kenneth R. Otis in the event for the amateur championship of Cuyahoga county, in her four-cylinder Stearns roadster, were the features of the day.

Alone in the car, she handled the wheel like a veteran of many racing meets and the speed at which she sent the racy-looking car up the incline brought forth a cheer from the crowd, while the announcement of her time of 54 3-5 seconds was responsible

finishing in the order named. In this event the winning car is determined by figuring the piston displacement, weight of car, gear ratio, percentage of grade and the speed attained. The driver must use the same gear all the way, for changing means disqualification.

Porter hill, on which the climb was held, is an excellent place for such an event, and it is more than probable that the climb will be held there again next year. The cars get a flying start of about 200 feet before they strike the tape—then 200 more of level ground, followed by a more than a quarter of a mile of stiff incline averaging more than 16 per cent. At the end there is 500 feet of very slight grade, allowing an excellent finish.

Considering the steepness of the incline, the time by the Chadwick in the trial against time after the scheduled events—36 seconds—is nothing short of wonderful. In the free-for-all the car made it in 42 4-5 seconds, and sanction was then granted for another trial by the committee. Like a skyrocket the flying car appeared as it shot up the incline, bounding over the rough surface of the ground. The road was perfectly straight, and from the finish line one could watch the machine as it flashed up the

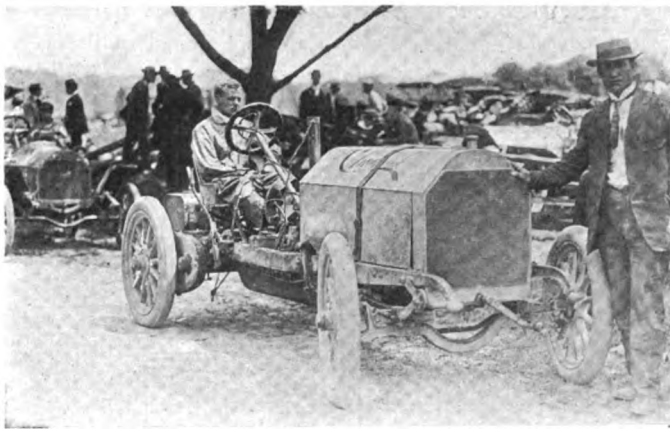

Haupt and His Fast-flying Victorious Chadwick.



Mrs. Otis and Her Prize-winning Stearns Roadster.

for the popular ovation which greeted her as she returned down the hill after making the record climb. The trophy offered in this event was a solid silver cup donated by the Warner Instrument Company, and must be won three times in succession before passing permanently to the victor. The name of Mrs. Otis will be the first to go on it, and she has signified her intention of competing for it again next year.

Taken all in all, the work of the Stoddard-Dayton was the most remarkably consistent performance of the entire program, for, competing with cars of its own classification in every event, it took three firsts and a second, and in every case bettered the times of its nearest competitors by several seconds. Cleveland has never seen a better electric event, the Columbus and Baker machines carrying off the honors. In the first event—that for electrics selling under \$2,000—the Columbus took first place in 1 minute, 15 seconds, winning over the Baker and Babcock machines, while in the event for electrics selling over \$2,000 the Baker roadster, running alone, made the climb in 1:7 flat.

Another feature event was the piston displacement handicap for all makes of gasoline cars, irrespective of power or number of cylinders. In this a single cylinder stands as good a chance as any four or six, for the winning car is determined by finding what percentage of efficiency is developed. In this event the Knox won, showing 77.5 per cent.—a very excellent performance, according to the Technical committee. The Pierce Arrow came in second with 70.7 per cent., the Stoddard-Dayton and Corbin

hill. Haupt's driving was remarkable, and veteran racing men who were on the scene could not help but marvel at it.

Just before the climb, what the crowd took to be two novel competitors appeared on the scene, and there was almost a small riot, due to the curiosity of the spectators to see the machines. They were two of the farmer's buggy autos that the International Harvester Company is building at its Akron factory and were driven over from there by the testers to see the climb. To say that their appearance created a sensation is to put it mildly.

The complete summaries follow:

STOCK CARS, \$850 AND UNDER.		
1. Ford .....	L. E. Manley.....	1:28 1-5
STOCK CARS AND RUNABOUTS, \$850 TO \$1,250.		
1. Overland .....	C. P. Brockway.....	1:17 3-5
STOCK TOURING CARS, \$850 TO \$1,250.		
1. Jackson .....	C. D. Paxson.....	1:52
STOCK RUNABOUTS AND TOURABOUTS, \$1,250 TO \$2,000.		
1. Jackson .....	C. D. Paxson.....	:56 2-5
STOCK RUNABOUTS AND TOURABOUTS, \$2,001 TO \$3,000.		
1. Stoddard-Dayton .....	A. O. Miller.....	:50 2-5
2. Knox .....	W. A. Bourke.....	:55 3-5
3. Jackson .....	C. D. Paxson.....	:56 2-5
4. Stoddard-Dayton .....	A. C. Miller.....	:59 1-5
STOCK TOURING CARS, \$1,001 TO \$3,000.		
1. Stoddard-Dayton .....	A. C. Miller.....	1:03 3-5
2. Oldsmobile .....	Andrew Auble.....	1:52 1-5
AMATEUR CHAMPIONSHIP OF CUYAHOGA COUNTY.		
1. Stearns .....	Mrs. K. R. Otis.....	:54 3-5



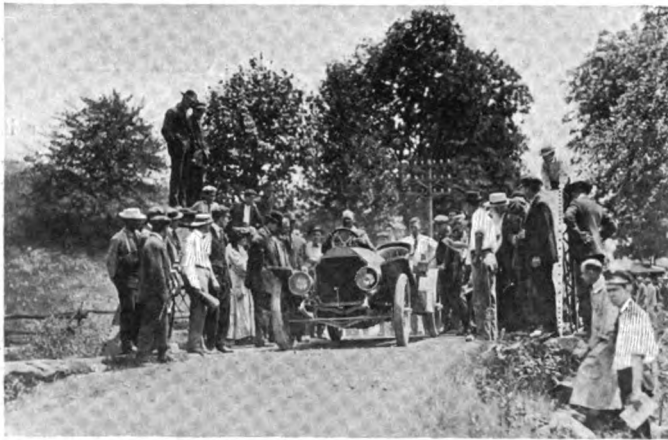

Miller in Stoddard-Dayton Which Won Three Firats.

<b>ELECTRICS, \$2,000 AND UNDER.</b>			
1. Columbus	W. F. Plastine	1:15	
2. Baker	E. Gruenfeldt	1:33	4-5
3. Babcock	F. S. Peck	1:34	2-5
<b>ELECTRICS, \$2,001 AND OVER.</b>			
1. Baker	E. Gruenfeldt	1:00	3-5
<b>SIX-CYLINDER STOCK CARS.</b>			
1. Chadwick	W. Haupt	:41	
<b>STOCK CARS WEIGHING FROM 1,432 POUNDS TO 2,204.</b>			
1. Stoddard-Dayton	A. C. Miller	:46	4-5
2. Knox	W. A. Bourke	:51	1-5
3. Jackson	C. D. Paxson	:53	2-5
<b>STOCK CARS WEIGHING OVER 2,204 POUNDS.</b>			
1. Chadwick	W. Haupt	:41	1-5
<b>PISTON DISPLACEMENT HANDICAP FOR GASOLINE CARS.</b>			
1. Knox	W. A. Bourke	77.5	per cent.
2. Pierce	W. W. Partridge	70.7	" "
3. Stoddard-Dayton	A. C. Miller		
4. Corbin	J. M. Matson		
<b>FREE-FOR-ALL.</b>			
1. Chadwick	W. Haupt	:42	4-5
2. Stoddard-Dayton	A. C. Miller	:45	3-5
3. Jackson	C. D. Paxson	:50	3-5
4. Corbin	J. M. Matson	:50	4-5
5. Knox	W. A. Bourke	:52	3-5
<b>TRIALS FOR RECORD OF THE HILL.</b>			
1. Chadwick	W. Haupt	:36	

**TO HOLD ANOTHER "DEAD HORSE" CLIMB.**

WORCESTER, MASS., June 15.—J. P. Coughlin, president of the Worcester Automobile Club, announces that the club will conduct still another automobile climb on Dead Horse hill this year, the next time in October, because the one on June 6 was so great a financial success; because he believes he can bring more racing cars and noted drivers here, including Vanderbilt Cup race entrants; because he believes he can secure many entries of 1909 stock cars, and because coming at so late a date it will come near being the winding up of the season.



International Harvester Buggy Autos at Cleveland Climb.

**MOTORCYCLISTS' NATIONAL MEET PROGRAM.**

The program of the sixth annual meet of the Federation of American Motorcyclists, which will take place in New York, July 1 to 4, has been determined upon. It fairly bristles with pleasurable activities and is as follows:

**Wednesday, July 1**—8 a.m.—Runs to Grant's Tomb, Lafayette Boulevard and Fort George Hill; 12 m.—Sightseeing tour in "rubberneck" coaches; for out-of-town visitors only; 2 p.m.—Run around Central Park; 4 p.m.—Run to Hall of Fame and Van Cortlandt Park; 8 p.m.—Excursion to Coney Island.

**Thursday, July 2**—8 a.m.—Bath run to Coney Island, via cycle paths; or bath and exhibition of life-saving at Dalton's Battery Baths, New York City; 11 a.m.—Run to Roslyn, via Jericho road; 3 p.m.—Tilting tournament at Roslyn; 8 p.m.—"Smokefest" and high old time at Roslyn.

**Friday, July 3**—7 a.m.—Start of 50 miles economy contest from Roslyn; 1 p.m.—Chowder party and annual photograph at Sea Cliff, L. I.; 7:30 p.m.—F. A. M. annual business meeting and election in Terrace Garden Hall, New York City.

**Saturday, July 4**—10:30 a.m.—Trolley excursion to Paterson, N. J.; 2 p.m.—National championship race meet on Paterson Stadium.

The annual F. A. M. national endurance and reliability contest will serve as a curtain raiser on June 29 and 30. The first day's run will start at Catskill, N. Y., and terminate in New York City, a distance of 174 miles. The second day's run will be from New York to Riverhead, L. I., and return, 176 miles, making a total of 350 miles.

**"AROUND THE WORLD", IN AUTOMOBILES.**

MONTCLAIR, N. J., June 13.—An automobile tour of the world was promoted here to-day with great success for the joint benefit of three local charities. A grand central station was established, from which trips were made to various cities, personified by various residences appropriately equipped for the day as to the costumes of the ladies in waiting and decorations.

From the grand central station the travelers were conveyed to Peking, the residence of William B. Dickson, on Llewellyn Road; Madrid, the residence of Albert French, on Upper Mountain avenue; Yokohama, the residence of William G. Frost, on Upper Mountain Avenue; Berlin, the residence of H. F. Holloway, Upper Mountain avenue, and Constantinople, residence of W. B. Millar, Park street. At Yokohama the guest of honor was Kokokichi Midzuno, the Japanese Consul-General at New York, and his wife and two children. At the city of Peking there were a large number of native Chinese, picturesquely attired, and at the other cities the scene was effective by reason of the gay costumes and picturesque decorations.

**TO OPEN WEMME CUP RACE TO THE WORLD.**

PORTLAND, ORE., June 12.—It is now proposed to throw next year's race for the Wemme cup open to the world and make it an event that shall attract the cars not only of every section of this country but also of every automobile building nation. The fact that Portland can offer military protection and a course, over which local stock cars averaged better than Briarcliff and equaled Savannah times, is deemed a reasonable basis for the promotion next time of a more ambitious race. The contest of May 30 was confined strictly to cars nominated by local dealers. The next contest will be in every sense of the word a free-for-all. Its promoters plan to make of it a Pacific coast classic and even cherish the hope that the prospect that the Vanderbilt Cup race may be run over what many have pronounced the finest national automobile race course in the world is not impossible.

**LOWELL'S FOURTH OF JULY RACE DOUBTFUL.**

BOSTON, June 15.—The possibility of holding the proposed 250-mile race on the Merrimac valley course near the city of Lowell grows more doubtful as the Fourth of July, the date for the event, draws nearer. The Lowell Automobile Club has been refused the use of the State militia to guard the course and it is also up against the possibility of not being able to secure a permit to close the roads.

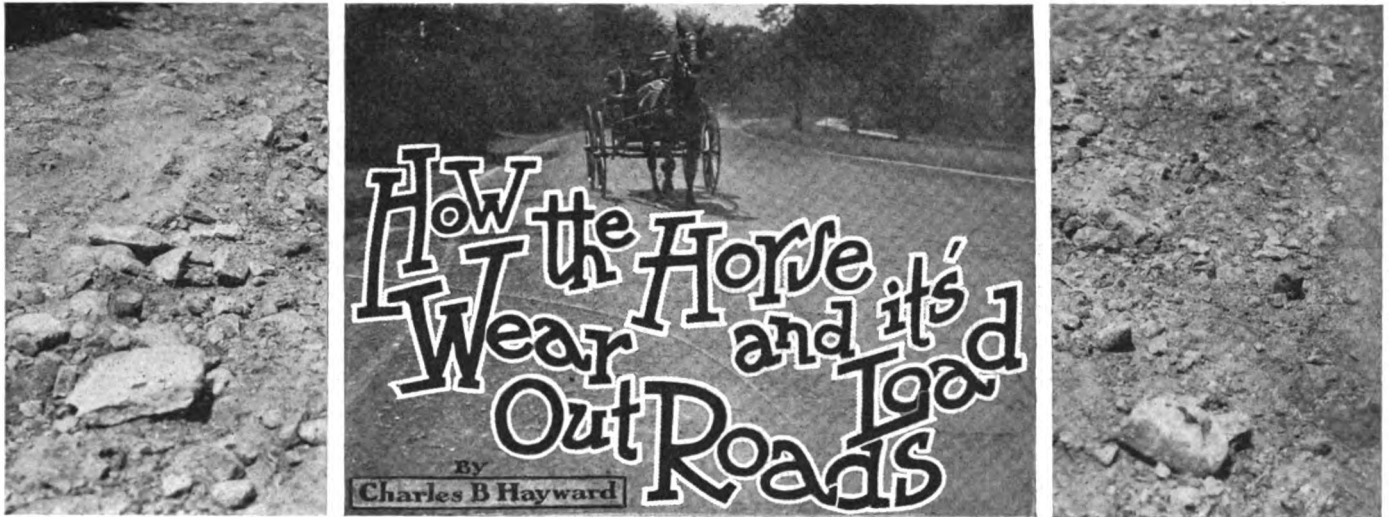

WHENEVER the hue and cry are raised against a thing, it is inevitable that the verdict of the unthinking mass will be "guilty," for those who follow a "blind lead" can see nothing else. Hence, only one side of a question is presented to view, and that in a most biased way. *Prima facie*, a good case can be made out for any cause, no matter how hopeless, provided its advocate be gifted with the necessary talent, and it is only when the defense is heard that the true state of affairs is brought to light. This is the case of the *Horse vs. the Automobile* in a nutshell, where the matter of road damage is concerned, though it is a case that is presented for public consideration solely as *The Automobile vs. the Road*, in the vast majority of instances, and the horse is not cited in any connection. Barrels of ink and miles of white paper have been consumed in raising the hue and cry against the automobile, on the score that it is a destroyer of the road, pure and simple. "Tax it to build new roads and keep the old ones in repair," cry the politicians and their constituents. Then tax it some more.

It would be foolish to attempt to assert that the automobile does no damage whatever to the roads; quite as foolish as it is to utterly ignore the pounding of steel-shod hoofs and the drawing of heavy loads on narrow steel tires, as factors in the process of wearing out a road. If any course of reasoning be indulged in on the matter, it is doubtless the somewhat fallacious one that the holes dug by caulks and sharpened shoes, and the deep ruts caused by absurdly narrow tires for the weight carried constitute *legitimate wear and tear*, while that for which the automobile is responsible is *destruction*. This appears to be the commonly accepted view, and because the damage that the automobile does is far more in evidence owing to its novelty and the fact that it is emphasized on curves, the toll that the horse and his burden take from the stone-shod surface are lost to sight entirely. Let it be granted without a quibble that the automobile does do more or less damage to the road, both for the sake of argument and because it is actually a fact. To admit half the contentions of its detractors, however, would be to damn it forever, and if even 50 per cent. of these accusations were founded upon fact, it would be necessary to rebuild every much-traveled automobile road at least once in two years.

#### Considering the Question Impartially.

But if the matter be taken up and considered point by point in a logical and reasonable fashion, rather than in the senseless and prejudiced manner that has characterized the majority of accusations against the automobile up to the present, it will be evident long before all the testimony is in that an exceedingly strong case can be made out against the horse, and even the most biased observer will be forced to admit that the horse has hardly a leg to stand on when it comes to putting in an adequate defense to the various charges that can be brought against him on the score of road damage. The point that appears to be en-

tirely lost sight of by the majority of those who are wont to accuse the automobile of tearing up roads by the roots is that a road, like everything else, is bound to wear out in time. From this the question arises, "Which wears it most?" When a study has been made of the nature of the damage caused by the horse and its load, it will be quite evident that, proportionate to his speed, the horse is more destructive of road surfaces than the auto.

#### About Steel or Rubber Versus Stone.

That this must be apparent to even the untechnical observer, when the character of the wear which is imposed on the surface of the road by the two different forms of locomotion is taken into consideration, calls for no argument. In one case there is the pounding of steel-shod hoofs, impelled by a force amounting to many hundreds of foot-pounds per minute, as the average horse weighs in the neighborhood of three-quarters of a ton, and lifts his hoofs several inches from the ground, while, on the other, there is the smooth rolling of soft rubber. This is aptly illustrated by the sketch showing the action of the hind leg and hoof of a horse as compared with the rolling action of the wheel of an automobile.

It goes without saying that a rubber tool would never be selected to work stone with, yet the automobile tire has actually been accused of breaking the stone of the roadway, and in support of this it is pointed out that steel studs and rivets are employed on the treads and it is the presence of the harder material in this form that does the damage. This, of course, does not take into account the fact that these steel projections are backed by rubber or leather, and that when a blow is received by a complex structure, such as the canvas-rubber-leather-steel combination of the automobile tire, the softest materials will naturally yield first. The steel studs may be harder than the stone of the road, but they do not strike it a blow, merely exerting a constant rolling pressure, a smooth surface being assumed. When a slight obstruction is met, something must give, and that something is the tire, which, to a certain extent, "absorbs the obstacle," the steel rivets receding as their backing is compelled to give way, instead of being impelled forcibly against the stone by a blow. Take any "single track" roadway and note the very distinct trough that the horse has carved out for himself in the center of the road, and which he is so loath to abandon that unless actually kept to one side by constant attention on the part of the driver, he will automatically resume his plodding in the softer track that he has carved out for himself.

#### "Do Not Drive in the Ruts."

Not long ago this was a very familiar sign along improved roads in rural districts, and it constituted the chief expression that the desire for good roads assumed among many agricultural communities. It serves to bring to light the fact that the horse-drawn vehicle is really responsible for as much, if not more,

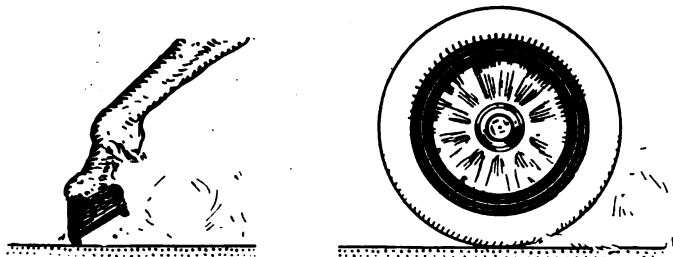

Methods of Road Destruction Graphically Compared.

It requires no abstruse mathematical calculations to demonstrate that three-quarters of a ton, resting on four steel-shod points of comparatively small area, and which are alternately lifted and brought down in pairs, will do much more to disrupt a surface than the rolling action of four wheels, even where the tires are shod with steel rivets.

damage to the road surface than is the animal itself. Gauged by the foot rule, the central path gouged out by the four steel-shod hoofs approximately equals the sum of those made by the narrow steel-tired wheels, though the necessity of "turning out" tends to widen the wheel ruts more than it does the horse's path. The damage occasioned by the tire is much worse in reality, as the ruts are invariably deeper throughout their length than is the case with the series of holes that constitute the central strip that is pounded out between the track of the wagon.

The illustration showing the section of a road carrying a wagon and its motive power shows in a striking manner exactly the nature of the damage occasioned by the horse and its load. Nor have they been exaggerated in the least, as it would be quite possible to select examples that could not be exaggerated, so bad are they in their natural state. Residents of New York will recall the frightful state that upper Seventh avenue, extending north from Central Park, was continually in between 1890 and 1900. During the decade intervening between those years it was found necessary to relay an entirely new macadam pavement from foundation up, on an average of once every three years, while between the total renewals of the pavement there were frequent occasions for repairs calling for the employment of tons of crushed rock and fine gravel for the top dressing, all of which was applied in the most approved manner and thoroughly wet down and rolled before traffic was allowed upon it. But, with the exception of the short periods following upon the conclusion of such operations, the avenue, which has long been one of the city's chief driveways, was a disgrace to the municipality. During the years in question there were not enough automobiles on Seventh avenue to do more than arouse the curiosity of those who saw them, and no one ever thought of accusing the power-driven vehicle of being the cause of the numerous deep ruts and wallows that extended to each curb.

#### Rain Is the Chief Cause of Damage.

After all, it is the rain that actually does most of the damage, but it is the work of the horse and its load that opens up the

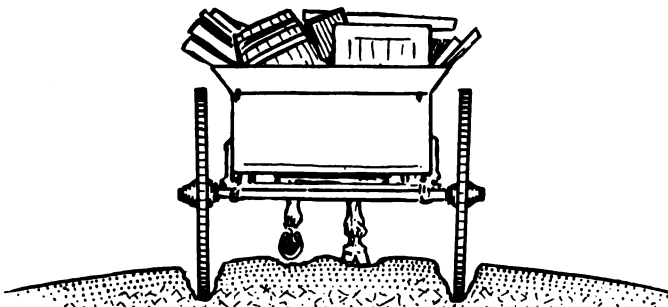

Nature of the Damage That Narrow Tires Do.

This sketch depicts a cross-sectional elevation of a road and serves to illustrate the nature of the damage done by both the horse and its load. A common dirt road has been selected for the purpose of the illustration, owing to the far greater depth of the ruts usually encountered. The damage done by the horse's hoofs is proportionately greater than would appear from the sketch, as owing to the dirt lying in the hollows, it does not show as plainly.

opportunity for the falling water and the stagnant pools left behind to do their work, by sinking into and disintegrating the whole road structure. Steel hoofs and narrow steel tires loosen and scatter the top dressing and the water comes to wash it away, and in a very short time channels are formed in which the water runs one way or another, according to the gradient of the road. A continuation of the grinding process of the steel against the bottom of the ruts loosens more material and more is washed away, which serves to explain the rapid manner in which the ruts are deepened, so that in time they open communication with the foundation beneath, and then the rain has an opportunity to undermine the entire structure.

Long before anyone ever thought of such a thing as an automobile ruining the roads men who knew what they were talking about, preached the doctrine of wide tires, and many attempts were made to pass legislation providing for the compulsory adoption of tires of a width calculated to bear the load the wagon was designed to carry. But most of these attempts were good efforts wasted, the legislation could not be passed, in the majority of instances, and the wagon user could not be brought to see that the innovation was entirely for his own benefit, in that a very much heavier load can be drawn over the same road



Result of Hoof-pounding on Park Macadam.

The difficulty of attempting to illustrate such damage by means of photographs will be apparent from this picture, as the hole itself varied from one to three inches deep, though all appears to be practically one level. The depth of the part in the background may be gauged to a certain extent by noting the shadow of the shoe cast downward in the hole.

with the same power where a wide tire is used, and the tire acts as a road maker, rather than a road destroyer.

As a matter of fact, there has been more blind prejudice to contend against where it has been a question of spending money for road improvement than has been the case where almost any other public improvement that could be mentioned has been at issue. And it is this feeling, heightened by the belief that the automobile is purely a rich man's plaything, that has been extended against the power-driven vehicle where its effect on the roads is concerned. Few have ever stopped to analyze the character of the damage caused by an automobile, nor, for that matter, have they ever stopped to give either side of the question a thought; they have simply joined in the hue and cry because it seemed to be the popular thing to do to decry the automobile and all its works.

#### More Counts in the Indictment.

A little study of the question serves to show that, whether walking, running or standing, the horse and its load never tend to improve the surface of the highway, but the wear is constant under any of these conditions, and not a few of the worst holes in the road surface are made by the horse, at the expense of his feelings while he is standing still, for it is then that he is under the greatest necessity of pounding, to relieve himself of the flies. The most rabid can scarcely urge any argument against the auto as a road destroyer while it is standing against the



Water Shows Up Road Damage in Its True Light.

Many macadam roads appear to be in excellent condition when viewed in a perfectly dry state, but a few pails of water thrown on the surface immediately brings out the ruts and depressions and strikingly reveals their depth.

curb. Here, at least, even those who are totally blind to hoof-marked holes and deep but narrow ruts, of which the automobile could not by any stretch of the most perfervid imagination be put down as the author of, must concede that the automobile is absolutely harmless.

Again, take the case of the automobile as it starts off, and as it is running at its average normal speed of 15 to 25 miles an hour, and the man who does not let his prejudice carry him away must admit that the automobile, with its broad rubber tires, not only does no damage to the road, but is actually a *road improver*. To those who regard this as a claim which goes beyond the legitimate, it is easy to make the following test, which cannot fail to convince the most skeptical. There are so many evidences of horse and wagon damage on the surface of any well-traveled road that the passage of any individual outfit leaves no perceptible trace, so completely does its imprint blend and become confused with the many that have preceded it. But if a stretch of a hundred yards or so be selected, and covered with a one or two-inch layer of fresh sand or earth, a fresh page will have been created upon which some striking records can be made.

#### Letting the Horse Incriminate Himself.

Have a horse and buggy, a delivery wagon or any of the other standard types of horse-drawn vehicles in daily use, driven over this stretch at a walk or trot, it does not matter much which, as the damage will not vary much in either case. The result will be a series of clean-cut depressions marking the passage of the wagon wheels by ruts which reach through to the hard surface beneath, and of holes which do likewise wherever the horses'

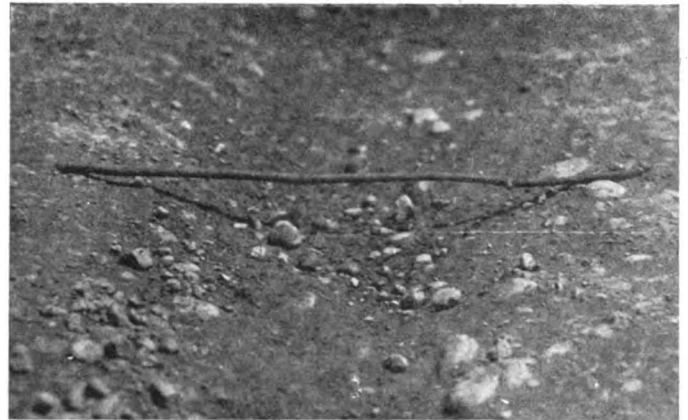

Enlarged View of a Narrow Rut in a Stone Road.

Apparently this rut is very wide and shallow, but in reality it was scarcely more than two inches wide at the bottom, showing unmistakably the work of the narrow iron tire, as it was not wide enough for an auto tire to "bottom" in.

hoofs have been planted. By driving the outfit first in one direction and then returning in the opposite direction over the same stretch, it will be at once apparent how greatly the latter operation increases the damage, as the horses' hoof-prints just overlap in such a manner that the holes originally made are approximately doubled in size.

To realize the extent of the damage thus created, for the marks in the soft surface prepared in this manner are merely duplications on a larger scale of what occurs to every road when a horse-drawn load passes over it, natural conditions must be copied still further. After the horses and wagon have passed over the prepared stretch once in each direction, a garden hose with a sprinkler attachment on it should be turned on the road, to simulate rain. A few minutes' wetting will cause every one of the depressions to fill up with water and it will be noted that the streams which form in the ruts thus created tend to carry off the top dressing of the road with them. In slightly magnified form, for purposes of demonstration, this is nothing more or less than what is constantly taking place on every road, and it is damage for which nothing but the horse and its load are purely responsible.

#### Repeat the Experiments with the Auto.

To provide the most striking contrast possible of the effect of the passage of a horse and wagon and of an automobile, have the prepared stretch returned to its original condition by raking out all evidences of the former's passage. Then have the automobile make its mark in the same unmistakable manner in which the horse has been compelled to accuse himself. But not at the

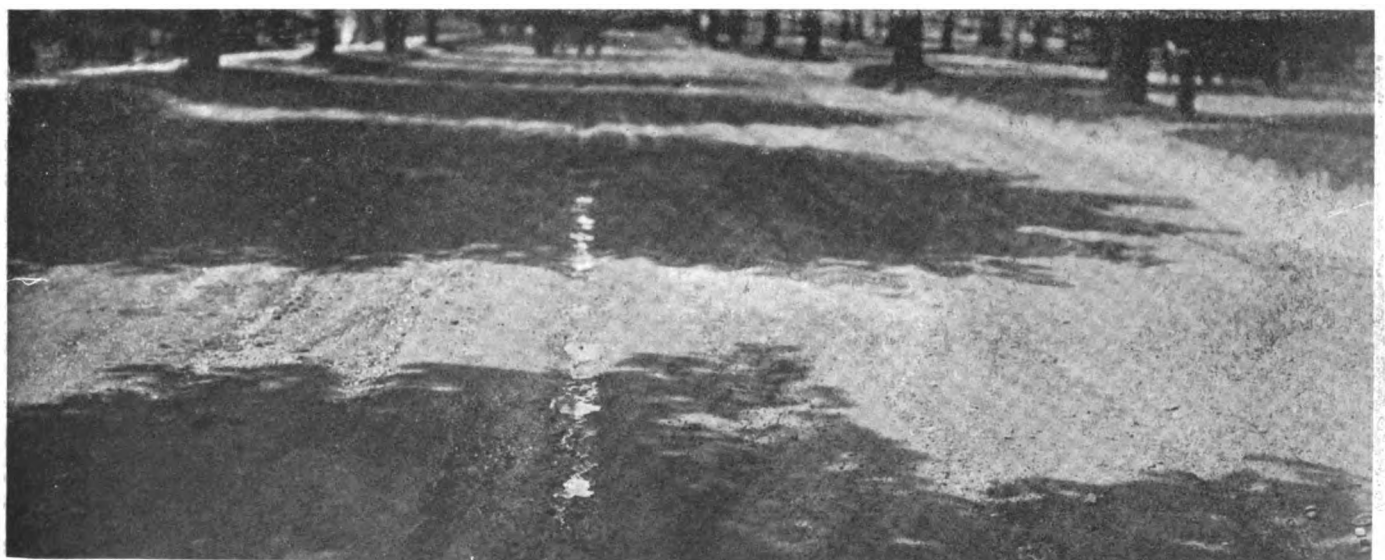

Striking Illustration of Damage Done by Horses and Narrow Tires on a New York Driveway.





Narrow Ruts, Three Inches Deep, in Macadam.

To better bring out the depth of these narrow ruts, twigs have been placed across them, but even this expedient fails to show them up in their true state by the aid of the camera, which does not lend itself well to this purpose.

gingerly pace of which he is capable; let the car be driven over the loose sand or earth at a speed of 20 to 25 miles an hour—five times faster than the average horse covers the ground, and note the result. In place of a series of holes and ruts two inches deep by two inches wide, assuming the loose dressing to be two inches of sand, there are a pair of broad, flat ribbons in which the material has been *compressed*, instead of being piled up at the sides of lines marked by the passage of the wheels. In other words, the automobile *does not create a rut*, but where there are narrow ruts it tends to fill them and flatten them out, thus acting as a road improver. This may be demonstrated by running the automobile over the prepared stretch before the marks of the horse's damage have been wiped out, and it will be found that the newly created ruts have been practically obliterated. But, to return to the tests as originally planned, it will be found that by driving the automobile backward and forward over the prepared stretch at speeds not exceeding 30 miles an hour, that the effect is really to *improve* the surface, the sand or earth being flattened out and compressed much the same as it is when a steam roller is run over it, except on a smaller scale. Applying the water test, as previously described, does not bring to light any such opportunity for the rain to wash away the surface dressing of the road, as is the case where a horse and wagon have passed over, as there are neither holes nor deep, narrow ruts in evidence, consequently there are no rivulets to wash their banks away in progressing downward, in accordance with the speed given them by the degree of the grade, nor any depressions to create puddles which seep through and undermine foundations. Few more conclusive or more convincing tests could be made than this.

#### Damage That the Automobile Does.

How is it, then, may well be asked, that the automobile is accused of doing such a great deal of damage, even by men who are not wholly given to exaggerating things, nor are wholly

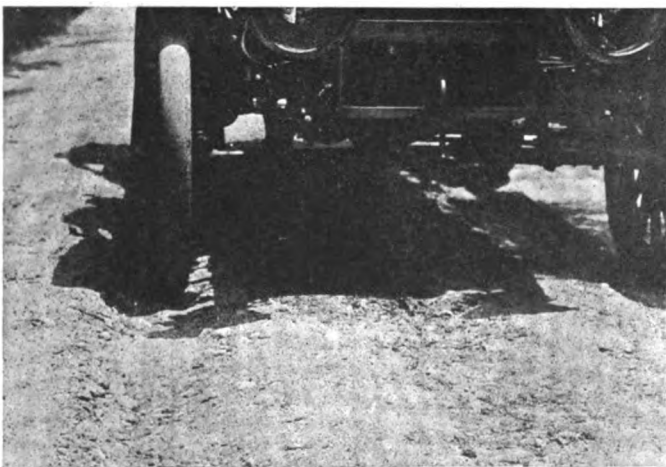

Showing Central and Side Ruts in a Road.

As well as a photograph can do it, this shows the typical form of damage illustrated by the previous cross-sectional sketch, with the exception that this is a macadam and not a dirt road.

prejudiced against it? As already made note of, it would be childish to go on record as stating that the automobile is wholly free from guilt in the matter of wearing out the roads. It does its share, but that share is far less than that of the horse under any circumstances. By employing tires shod with non-skid bands, chains or similar traction-giving devices, in the foregoing experiments it would be found that the impressions left would not be so smooth; instead of the plain compressed strip there would be the marks of the projections adorning the tires, and the continued passage of such tires over the same strip would not compress it as effectively as where smooth tires were used, but even at speeds up to 25 or 30 miles an hour the effect could not be compared for a moment with that occasioned by the passage of the horse and wagon.

By increasing the speed of the car to 40 miles an hour and over, it would become apparent that the rapid passage of the rubber over the surface created a certain amount of suction that caused some of the finer particles of the dressing to be lifted bodily and these will be seen following the wheel for a few inches as it rolls along. In a lesser degree, the same thing happens when an automobile is driven over a macadam road, but it is necessary to run the car at speeds of from 40 to 60 miles an hour in order to make the effect apparent. Examination of a road surface that has been treated in this manner shows it to have a bare appearance, the finer pebbles and filling material having been removed as if with a broom. But in no case is the surface broken into or cut through in the manner invariably caused by horse traffic, as revealed by narrow ruts and hoof holes that cover a very large part of the surface.

#### Auto Damage May Be Readily Prevented.

The crucial test of the horse's vastly greater powers of road damage is to be found in the fact that this sweeping of the fine material out of the interstices of the top dressing of stone by the automobile when running at high speeds does not occur where any binding material, such as tar and oil, has been employed, but horse hoofs and narrow steel tires cut through a road surface regardless of the nature of its construction. As compared with this, the greatest damage occasioned by the automobile is to be attributed to the practice of taking curves at high speeds. Holes and ruts are no worse on curves than straight stretches, merely because a horse and wagon do not travel around a curve at any speed, but the automobile does, and because of the lack of banking necessary to permit this without damage the car slides laterally in making the curve, and tends to pile up the loose material thus created, at the outer edge.

It is unfortunate that there have not been more numerous opportunities of actually comparing the damage done by horses and wagons and by automobiles on roads of similar nature, but, so far as known, the only case where this has been possible has been on the *Champs-Élysées*, Paris. This is a broad avenue divided into three roadways, the central one of which is exclusively for automobiles, while the outer ones are for horse traffic. The experience of a year has shown that a very much higher rate of speed is maintained in the automobile section, yet accidents have been much rarer than on the horse drives. Where the state of the wood pavement itself is concerned, the only result of a year's use by the automobile has been a gradual change in color from the original brown to a black, caused by the oil and gases, while the horse drives *have sunk irregularly and have become pitted in thousands of places all over their entire surface*, as the result of the pounding of steel-shod hoofs. The pavement in question was newly laid at the opening of the year covered by the record in question, so that it would not be possible to have had better conditions to make a comparative test, as from the time it was first put down until it was examined at the end of the twelvemonth, no horses were allowed on the automobile driveway in the center, and cars were absolutely forbidden the side drives. To-day, the central drive is in far better condition than it was at the outset, as it has been compacted and compressed all over, while the horse drives are ready for expensive repairs.

## SOCIETY OF AUTOMOBILE ENGINEERS TO MEET AT DETROIT

WHAT is generally conceded to be the center of automobile manufacture in the United States has been selected as the city for the Third Annual Summer meeting of the Society of Automobile Engineers, namely, Detroit. The summer meeting this year is to be held at the same time as that of the American Society of Mechanical Engineers, both organizations making their headquarters at the Hotel Cadillac, and there will be a mutual exchange of courtesies between the two societies. As a matter of fact, not a few of the visiting engineers are identified with both. The meeting of the A. S. M. E. will open Tuesday, June 23, while the automobile engineers will not convene until Thursday of the same week, the meeting lasting three days.

The Detroit entertainment committee, of which H. E. Coffin, of the E. R. Thomas Detroit Company, is chairman, assisted by Henry Ford, Russell Huff, James H. Herron and Alanson P. Brush, has prepared an attractive program to enliven the stay of the engineers. Thursday morning both organizations will go aboard a special steamer and will be carried up the river to witness the launching of a 10,000-ton lake freighter. In the afternoon one of the local plants will be visited and inspected, and in the evening papers will be read on "Autogenous Welding and Its Application to Automobile Construction," by E. S. Foljambe, and "The Storage Battery in Automobile Work," by Bruce Ford, the former being accompanied by demonstrations of the various processes employed in welding and cutting metals with the aid of the oxy-acetylene burner. Marvelous results are obtainable with this process, and it is expected that the presentation of this paper will bring out a very interesting discussion. Mr. Ford is an authority on the storage battery and the discussion of his paper is also expected to bring out numerous points of interest.

During the morning of the next day—Friday—the automobile engineers will participate in the discussion of the paper by Henry Souther on "Clutches," which was presented before the American Society of Mechanical Engineers at its New York headquarters, May 12 last, and which has already been published in full in THE AUTOMOBILE. During Friday afternoon, the S. A. E. members will participate in a river excursion at the invitation of the mechanical engineers. The steamer *Britannia* will leave the Detroit, Belle Isle and Windsor ferry dock at the foot of Woodward avenue at 3 p.m., sail round Belle Isle, thence down the river to Amherstburg and to the head of Lake Erie, returning to Bois Blanc island, where supper will be served, returning to Detroit later in the evening.

"Some Recent Developments in Magneto Ignition," by Otto Heins, is the paper scheduled to be read Friday evening, and in connection therewith Mr. Heins will show a large number of lantern slides, illustrating the development of ignition during the past 20 years or more. Saturday morning will be devoted to a visit of inspection to one of Detroit's chief industrial show places—the plant of the Packard Motor Car Company—after which the members will be taken to the Detroit Boat Club, where lunch will be served at the invitation of J. G. Rumney, of the Detroit Steel Products Company. Following this there will be an automobile run through Belle Isle Park and environs, of which Detroit is justly proud. In the evening, papers by Frank Beemer, on "The Unit System of Power Transmission in Automobiles," and by A. L. Dixon, on the "Increased Efficiency of Single Motor Drive," will be read and discussed. It is anticipated that Cleveland will be suggested as the place for the fall meeting, to be held in September or October.

## INCREASING THE POWER BY CONCENTRATING THE CHARGE

By J. H. K. McCOLLUM.

TO be able to increase the output of a gasoline motor by 110 per cent., without paying more for the improvement in capacity of the motor than the latter is worth must be conceded as something worthy of more than passing mention. But this has been done with the aid of an attachment of which the writer is one of the patentees, and it is the purpose here to describe it and show its workings. First, as to the latter and the manner in which the results were obtained. In our laboratory in Toronto, we have a standard Fairbanks-Morse four-cycle gasoline engine, equipped with this attachment. We have tested this engine on the brake in every possible way (varying the tension of the inlet valve spring and the valve opening, varying the time of the spark, etc., etc.), and noted carefully the power developed by the engine in its original form.

Now, from exhaustive tests, with our attachment in use, we find that we have obtained as high as 110 per cent. more power at the same speed, using extra gasoline or gas in almost exact proportion to the extra power obtained. The attachment was applied as follows:

A hole was bored through the side of the cylinder through the water jacket and cylinder walls at a point where the hole would be just uncovered by the top of the piston when the latter was at the lowest point of its downward stroke. The engine is an upright. We tapped this hole with a tapered tap and screwed into it a tapered nipple cut in the lathe, and to this nipple fastened a valve casing and poppet valve operated from the secondary shaft, the valve in this case opening away from the engine, being timed to open during the suction stroke only and close during the compression stroke only, remaining closed during the remainder of the cycle. A pipe connecting this valve casing to the outlet valve chamber of a small compressor is

used. The compressor is fitted with automatic valves and is run from the main shaft of the engine. It is better to use a separate carbureter for the compressor.

With this system the engine is allowed to draw in the full ordinary charge of mixture as usual, but when this ordinary charge is all in we force in another charge of mixture which is added to the ordinary charge, and thus we have a pressure of mixture in the cylinder above the pressure of the atmosphere before the piston commences to rise on the compression stroke.

The whole secret of the success of this system is in the conjunctive action of this two-to-one valve and the piston of the engine. This valve is driven by an easy, slow action, noiseless cam and a fairly large roller, and, although the valve opens about when the first half of the suction stroke is completed, or when the piston is only about half way down on its suction stroke, the extra charge does not go into the cylinder until the top of the piston uncovers the said hole or port bored through the side of the cylinder, but the moment the piston commences to rise its edge covers and closes the port and entraps the ordinary and extra charges combined, and when the piston has finished about half of the compression stroke the two-to-one valve closes and remains closed until the next suction stroke is about half completed.

In a four-cylinder, 4-inch by 6-inch engine a fifth crank is used, driving a double-acting compressor, having a 5-inch bore and 6-inch stroke. This compressor cylinder is very little higher than the engine cylinder, on account of the narrowness of its piston, and of about the same outer diameter. With a combination of this kind, the power of the engine is practically doubled.

The best arrangement is to have a throttle valve between the compressor inlet valves and its carbureter, and allow the com-

pressor to run all the time, although, if desired, the compressor can be gear and clutch-driven, so that when not in use the engine can be run without running the compressor. When not using the extra or forced charge, the throttle valve is closed and the compressor piston acts similarly to the vacuum dash pot of a Corliss engine, the only extra work the engine has to do being to overcome the friction of the compressor, and we find this so small, especially where four or more cylinders are used, as to be practically negligible.

When the compressor throttle is closed and the engine running only on the ordinary charge, the compression is about 50 or 60 pounds, this giving an easy running, long life engine, but when the compressor throttle is opened and the extra charge added to the ordinary charge, the compression can be put up to any pressure desired, according to the bore and stroke of the compressor, and the amount of opening of the compressor throttle, until the point of preignition is reached, it even being

possible, where an even speed can be obtained, to run the engine with the charge being thus fired by its own compression.

The power obtained by this higher compression, and, consequently, higher explosion pressure, from the use of the extra charge, we find, by actual demonstration and careful tests, to be a different matter entirely from the power obtained by raising the compression of the ordinary charge without the extra charge by a diminished or decreased clearance. This system also allows of the engine running half power on a wide-open throttle, thus giving greater efficiency. With the ordinary engine in automobile, motor boat and other uses at all times except when running developing full power, the engine is running with the compression below the maximum that can be obtained, as is well known, so an engine working under our system will evidently have a greater advantage in higher compressions at lower powers and will only use an amount of fuel proportionate to the actual power output.

## SOME VARIATIONS IN TIMING SHOWN BY FOREIGN MOTORS

By C. F. REDDEN, OF THE STUDEBAKER BROS. COMPANY OF NEW YORK.

THERE has been recently published a table which gives the valve timing on many of the best known foreign cars, and it is interesting to note the variations in timing used by several of the more prominent foreign manufacturers. At the first glance it might appear that the valves of an internal combustion motor should open at dead centers for the induction and exhaust strokes, and should remain entirely closed during the compression and power stroke. This, however, is not the case, owing partly to the inertia of gases at high speeds, and also partly to the time taken for the complete combustion of even a perfect mixture; the advance of exhaust opening variations from 30 degrees, which is a minimum, to 58 degrees which is a maximum.

The consensus of opinion among foreign manufacturers, is to close the exhaust valve exactly on dead center. Some few manufacturers let the closing of the exhaust lag 5, 10, and even in some cases 28 degrees. The object of this exhaust valve timing is to rid the cylinders as completely as possible from the product of combustion by opening the exhaust valve about 40 degrees early, and holding it over about 10 degrees late. The inlet valve opens anywhere from 1 to 20 degrees after the exhaust valve closes. The best practice, however, seems to favor opening the inlet valve immediately after the exhaust valve has become seated, say from one to three degrees on the flywheel.

The closing of the inlet valve invariably shows some lag, in one case this lag ran as high as 58 degrees while the average is about 20 to 25 degrees.

Many autoists do not understand why it is not desirable to close the inlet valve directly on dead center, they arguing that by allowing the valve to lag, a certain amount of mixture will be forced out. While this seems a logical argument, it is nevertheless a fact that the incoming gases do not follow directly upon the piston, but a vacuum, so to speak, exists between the piston head and the incoming charge. Theoretically, the right time to close the valve is at the moment of the meeting of the piston to the incoming charge. The problem of correct valve timing is one that holds a good deal of interest, because the variable engine is such an important factor.

If a motor always ran at constant speed, only a very little experimenting would be necessary to determine the proper valve setting to give the maximum power at that particular speed, but the wide limits between which the gasoline motor must operate makes it necessary to strike an average in setting the valves that will give the best power for all-around service. Probably the averages as set forth above are pretty nearly correct, at least they show what has been considered good practice abroad, and form practically the first data published on the subject.

### HOW MAXIM FOOLED THE OXEN OWNER.

HARTFORD, CONN., June 15.—H. P. Maxim, the designer of the Maxim-Goodridge electric, had a peculiar experience while returning to Hartford from New London the other afternoon. On the shore road between Lyme Ferry and Niantic is a steep hill. At the bottom of this hill sits a farmer and a yoke of oxen, ostensibly to assist those in trouble. Now, then, half way up that hill there has been dumped a lot of soft loam and turf into which the wheels of a car will sink. Chain grips are useless, likewise any other such contrivance. The ruralite at the bottom of the hill is Johnny-on-the-spot and captures a little loose change. But the inventor of the noiseless gun went him one better. The car was unloaded of its passengers who walked up the hill. All turned to and cut a lot of brush and bough and these were placed over the bad spots. Then, as the car had an abundance of power, the ascent was made without the aid of those oxen, and the farmer who tried to make it appear that the dumping of the loam and turf on the road had been done to repair the highway lost a tip, and well he might.

The attorney of the Automobile Club of Hartford has been notified and will see to it that this bad spot is repaired at once and that local talent lets it alone in future.

### PRESSURE LIMITED BY ATTACHMENT MEANS.

It is a more or less general opinion that there is danger of inflating a tire too hard, and many autoists believe in this to the extent of damaging the tire equipment of their cars by not inflating the tires hard enough. In order to ascertain the truth of the matter definitely, the Pennsylvania Rubber Company, Jeanette, Pa., had its testing department make an investigation. A tire was mounted on a regulation clincher rim, and subjected to a constantly increasing pressure until the gauge showed 600 pounds to the square inch. At this point, a slight expansion of the walls of the shoe was apparent and they were so hard that they sounded like wood upon being struck.

Just after passing the pressure in question, the bead was blown out of the rim for a distance of about 9 inches, showing that a well-constructed pneumatic tire will stand a pressure great enough to blow it off the rim before bursting, thus branding as a fallacy the belief that blowing the tires too hard will be apt to cause a blowout. Apart from the stretching of the walls, no damage was apparent and there was no rupture of the fabric. The Pennsylvania Rubber Company will continue to experiment and expects to find some means of holding a tire down sufficiently fast to determine at what pressure the shoe will burst.

## LETTERS INTERESTING AND INSTRUCTIVE

### DETECTING FAULTS IN A SECOND-HAND CAR.

Editor THE AUTOMOBILE:

[1,417.]—Will you please answer the following questions in "Letters Interesting and Instructive": (1) How to test for faults when buying a second-hand automobile. (2) How to find the primary terminals of a coil that is not marked. (3) Why is it necessary to have the secondary circuit complete when the primary is closed? (4) How is the spark retarded and advanced on the Renault car?

ROBERT BURTON.

Tarrytown, N. Y.

(1) Your first question would involve a rather lengthy reply, so we would refer you to Letter No. 1,170, which appeared on page 247 of THE AUTOMOBILE of February 20, 1908, in the answer to which the subject is gone into to the extent of almost two columns. (2) Take a set of several dry cells connected in series—the usual manner in which they are employed on a car—and attach one terminal to a binding post of the coil. Take the other wire in the hand and wipe its bare end across the other terminals of the coil, one at a time. If there is no visible effect, change the first wire to some other terminal and again proceed as before. If the battery is connected to the primary, making the circuit in this manner will cause quite a visible spark and a snap, whereas if only the secondary coil happens to be in the circuit there will be nothing seen, as the low voltage of the battery is not sufficient to overcome the high resistance of the secondary winding. Nor will there be any effect where one wire is connected to a primary terminal and the other to the secondary. The method may be varied by using a common electric bell or buzzer in the circuit, in which case it will sound when the primary is completed through it, and it will not ring through the secondary. (3) In order to prevent the secondary coil from being burned out. Every time a current is sent through the primary and the circuit suddenly broken, a corresponding current of extremely high voltage is immediately induced in the secondary. If the gap between the terminals of the secondary winding be so great that the coil cannot bridge the distance, the current will find the path of least resistance. On this account the resistance of the air-gap that a coil of a certain size will bridge is calculated to be less than that of the resistance of the insulation between its windings and where the former is allowed to greatly exceed the latter the insulation is broken down. Many makers put what is termed a "safety gap" on their coils, the resistance of this opening being the maximum that the coil will safely bridge, so that if the terminals are moved too far apart the spark jumps at the safety gap. (4) The Renault car is designed to run on a fixed point of ignition, no provision being made for advancing the spark in the ordinary manner. A magneto is employed and provision made for retarding the time of ignition sufficient to facilitate starting.

### MORE ABOUT CUTTING A CRANKSHAFT DOWN.

Editor THE AUTOMOBILE:

[1,418.]—In your answer to inquiry No. 1,401 the statement that reducing the crankshaft diameter from 2 inches to 1.1-2 inches amounts to a reduction of 25 per cent. in strength, is slightly inaccurate. The torsional strength of a solid, circular shaft is proportional to the cube of the diameter. The 1.1-2-inch shaft would, therefore, have only about 42 per cent. of the power-transmitting capacity of the 2-inch shaft.

H. H. F.

Gallon, O.

If the statement in question had been made in the way you put it, there could be no doubt as to its lack of accuracy, but if you will read it again we think it will be plain that the 25 per cent. reduction spoken of referred to the amount of the reduction and not to the strength. However, we wish to thank you for calling attention to this important factor, which should be further cause for the inquirer in question abandoning the project of cutting down his crankshaft in the manner contemplated.

### "WORN VALVE STEMS MAY BE THE CAUSE.

Editor THE AUTOMOBILE:

[1,419.]—I have a two-cylinder Reo car which has lately shown a tendency to overheat, boiling the water, even after a very short run. I cannot discover any cause for it. The mixture seems to be about right. I judge this from the fact that the engine develops apparently full power and runs well. The pump is in good shape; no pipes are clogged. The lubricator is not feeding an excess of oil, neither is there an excess of oil in the crankcase. The valves are absolutely correct in accordance with the marks on flywheel, both the inlet and the exhaust. There is no carbon deposit in either cylinder, the cylinders being quite clean. Heretofore I have never noticed any such trouble with this car. I shall be pleased to receive any information that you or your subscribers may be able to give me as to the probable cause of this overheating, which as yet I have been unable to discover.

I would also like to be advised as to the horsepower of a 4-1-4 by 4-1-2-inch motor with offset cylinders, and running at an average speed. What would be the rating of such a motor under the formula used by the A. L. A. M.?

Columbia, S. C.

A. M. GIBBES.

Wear of the cams, tappets and valve stems may be the cause of the overheating you complain of, as it would not require much loss from the faces of the various moving parts that come in contact to cause a more or less appreciable difference in the operation of the valves, and as this wear tends to bring about a later action, it may be sufficient in the case of the exhaust valve to retain the burnt charge considerably beyond the time at which it should be allowed to escape. Where a motor runs at a speed of 800 r.p.m. or over, it will be evident that it is a matter of very small fractions of a second. Or, as called attention to by another correspondent recently, the cause may be due to the deposit of a fine film of scale on the inside of the circulating pipes and radiator. This scale is of a mineral nature, and, in addition to being an excellent nonconductor of heat, it is deposited in such intimate contact with the metal that the latter is practically insulated and its radiating power entirely lost and the cooling system is very inefficient.

Assuming a piston speed of 1,000 feet per minute, the output of this motor would be 28.89 horsepower, according to the A. L. A. M. formula.

### INDICATIONS OF A GENERAL OVERHAULING.

Editor THE AUTOMOBILE:

[1,420.]—I recently purchased a second-hand two-cylinder Model N Ford automobile. Have had considerable trouble with it, and as a subscriber am writing for your opinion as to the cause of the trouble. The batteries are new and the vibrators also, all perfect. Only one cylinder fires regularly, although I get a good spark from both plugs. The engine will not speed up unless the spark is very high. Opening the throttle has no effect until wide open, then the engine will speed up a little. When I advance the spark very high, the engine will speed up considerably. When the engine is running at high speed there is a popping noise in the exhaust, but if I shut off the gasoline in the carbureter, or feed more, the engine dies down. At times the water boils when I have only run the car a few minutes.

Cranmoor, Wis.

H. F. WHITTLESEY.

We should say the motor was in need of a general overhauling, as is usually the case with a car acquired at second hand, and the most effective way to do this is to take it all down, clean out the crankcase, cylinders, valve pockets and the like, adjust the bearings and replace any parts that seem to be badly worn. Clean the timer and carbureter out thoroughly and after reassembling the motor see that it is timed properly. If there are any markings on the periphery of the flywheel, follow these, but if not the inlet valve, taking the forward cylinder to work on, should be set to open at the upper dead center and should remain open until the piston has started upward on the compression stroke, the equivalent of 15 to 20 degrees on the flywheel circle. The exhaust valve should open 30 to 35 degrees in advance of the lower dead center of the power stroke, again measuring on the flywheel



circle, and should remain open until the upper dead center on the exhaust stroke has been reached. The timer should be set so that the contact of the cylinder in question corresponds to the upper dead center of the piston. The spark advance lever should then be about one-third way from the end of its travel on the sector, *i.e.* one-third way from the bottom, assuming that the lever moves upward to advance. This will then give two-thirds of its travel for advancing the timing of the spark and one-third for retarding its occurrence. As the cams are fastened to the camshaft, or are integral with it, and the timer is designed to run synchronously with the motor, timing one cylinder suffices for both. To adjust the carbureter open the needle valve sufficiently to enable the motor to be started; then close it very slowly until a point is reached where the motor does not get sufficient fuel to run regularly. Reopen it slightly until the motor again runs without missing and fasten the needle valve in place at that point. Try the motor at various speeds on the throttle and see if it responds properly. If not, see that the auxiliary air valve is in good working order. With a good overhauling of this kind and proper timing, the motor should run as well as it ever did.

### QUERIES CONCERNING THE TWO CYCLE.

Editor THE AUTOMOBILE:

[1,421.]—I would like to ask a few questions concerning the working of a two-cycle engine for automobile use: (a) What percentage greater consumption of gasoline has the two-cycle over the four-cycle, both motors having the same size cylinders? (b) What is the first fault to be found in the two-cycle motor after a few thousand miles' run? (c) What is the crankcase compression of a two-cycle engine? (d) Is the crankcase ever known to leak after a few months' use? T. C.

Putnam, Conn.

(a) We think the two-cycle motor requires about 10 per cent. more fuel than one of the four-cycle type of the same size, but have never had any personal experience with a two-cycle motor under the varying and trying conditions of automobile service and so cannot make any definite comparison between the two, nor do we know that the above holds good. According to a well-known maker of marine and stationary motors of both types, the two-cycle, when running for long stretches under steady load, requires fully 33 1-3 per cent. more fuel than the four-cycle of the same size, but economy test records of two-cycle automobiles would not appear to substantiate this in the latter case. (b) We presume crankcase leakage would be the first trouble to develop. (c) The compression is usually three to five pounds per square inch, but in certain makes runs as high as eight pounds to the square inch. (d) Not where the joint is properly made in the first place and the motor is not abused.

### ABOUT REPAIRING RADIATOR LEAKS.

Editor THE AUTOMOBILE:

[1,422.]—In your issue of May 14, in re leaks in a honeycomb radiator, you say "there is no way of repairing by simply injecting something into the water," and, in general, you are correct, but if it is a very small leak—a drop or two at a time—a handful of flour put in with cold water and when the radiator is cold, will effectually cure the trouble. H. W. BARTOL.

Chateau de Ste. Helene, Nice, France.

In stating that there was no way of repairing a radiator merely by putting something into the water, we meant to infer that there was no practical way, as inquiries to this department are seldom intended to bring forth information concerning repairs of a temporary nature. A handful of bran will effect a temporary repair on the road, but anyone who has ever tried the expedient is never anxious for a repetition of the experience, as the bran becomes entrained in various parts of the circulating system and causes endless annoyance. Flour may serve to stop very small leaks, as you say, but where the leak is occasioned by a weak spot the use of such a remedy is merely putting off the evil day, as the vibration and jolting will extend the damage and sooner or later the

flour will drop out and then the orifice will be much larger than it was originally and will no longer be susceptible to repairs of this kind. At best, the latter are only makeshifts, and while they are well worth while knowing for emergency use, where it is a question of bringing a car in, they are certainly not to be recommended for every-day use where a permanent repair is desired.

### DOUBTLESS THE BEARINGS ARE AT FAULT.

Editor THE AUTOMOBILE:

[1,423.]—Will you please give me your opinion of a two-cylinder opposed engine and why it will knock when you advance the spark, and also knock when you put on more power, and as you advance the power it will even lose its speed on level ground when on high gear? When car is running on low gear it runs smooth and don't seem to bother at all. Ignition is good, use storage battery and Heinze coil and Schebler carbureter, Rajah spark plugs. Will you please suggest something to do so that I can overcome my engine from knocking?

Minneapolis, Minn.

ANXIOUS SUBSCRIBER.

Your statement of the case would appear to indicate that the engine is in more or less need of a general overhauling. The bearings must have too much play, which would account for some of the knocking, particularly that which occurs when the load on the motor is increased. A motor will usually run smoothly on low gear and when not loaded, even though its bearings be loose, but the extra strain never fails to make this apparent. Advancing the spark too much will always cause a knock, as the explosion then occurs slightly before the piston has reached the upper dead center, and it has to work against the pressure thus set up. The knock followed by the opening of the throttle may be occasioned by poor carbureter adjustment, the mixture being either too weak or too rich, one or the other of these conditions always causing it to burn so slowly that the exhaust is not effected in time to relieve the cylinder of all pressure before the valve closes.

### MAKE-AND-BREAK IGNITION WITH BATTERIES.

Editor THE AUTOMOBILE:

[1,424.]—I have a 1½-horsepower motor using the make-and-break spark. All wiring is perfect, but new batteries do not last more than about one hour. What is the cause? B. SEYFERT.

Bristol, Pa.

The trouble does not lie with either the batteries or the motor, but with the make and break ignition. Batteries, and particularly dry cells, are not adapted for service with this type of ignition, especially on a high-speed motor. Doubtless the make and break contact is not of the finest description, judging from the size of the motor to which it is attached, and the sparking contact is of unusually long duration, thus wasting half the energy of the batteries, while the legitimate needs of the igniter consume the other half. The best remedy is to convert the ignition to high-tension, or jump spark.

### CONCERNING FLYWHEEL SIZES.

Editor THE AUTOMOBILE:

[1,425.]—Is there any simple rule or formula you can give us for figuring the size of flywheel we should have for a three-cylinder two-cycle motor, with bore of 6 1-2 and stroke of 6 inches? Would the same flywheel be right that it required for a six-cylinder four-cycle engine? ZIEGLER & BINSSE.

Columbus, O.

The data you give is altogether insufficient as a basis upon which to give exact information, while the wording of your first question implies somewhat of a misconception of conditions. Flywheel size, within certain limits, is determined primarily by the space that is available for the placing of a flywheel. As a general rule, it is well to have a flywheel as large as possible, since the larger it is the lighter it can be for a given balancing effect. A flywheel, for instance, of a given size is simply doubled in efficiency by doubling its weight. By doubling its diameter, however, without increasing its weight, its efficiency is quadrupled—

thus proving the desirability of large size and especially of concentrating the weight in a broad and heavy rim. A three-cylinder, two-cycle engine of ordinary construction requires, other conditions being equal, a slightly heavier fly-wheel than a six-cylinder, four-cycle of the same dimensions, because of the crankcase compression, the lighter crankshaft, etc. It is impossible to give exact figures for your particular engine without knowing not only the bore and stroke, but also the compression, the minimum, normal and maximum speed, etc. And, in any case, the practice even of the best designers is unsettled in this regard.

#### PERMISSION TO ERECT ROAD SIGNS IN MICHIGAN.

Editor THE AUTOMOBILE:

[1,426.]—I should appreciate it if your correspondence department could give me some information of the Michigan law bearing on the subject of sign and guide posts. Who is the proper authority to grant permission for the erection of road signs?

Ypsilanti, Mich.

HERBERT L. CONNELL.

We doubt if you will find this is a matter of State law, but rather something over which towns and counties have direct jurisdiction, in which case the town or county authorities could give the necessary permission. However, this is something on which the States differ very radically, many making no provision at all. You can doubtless find a digest of the State laws in any public reference library in a large city. It is naturally a matter that would not be found in a motor vehicle law as where they exist sign post laws are usually of long standing, unless of very recent passage.

#### ABOUT BATTERY AND DYNAMO IGNITION.

Editor THE AUTOMOBILE:

[1,427.]—I have a four-cylinder engine in my automobile, and I am thinking about putting in a storage battery and dynamo to charge it. Now, how is a storage battery? Can you depend upon them? I have been using dry batteries. Can you start an engine with a magneto without batteries?

Louisville, Ky.

GEORGE PERRY.

A storage battery constitutes a perfectly dependable source of ignition current, and on cars having engines of more than two cylinders is usually found to be much superior to dry cells. A magneto, of course, represents the best form of ignition apparatus for the multi-cylinder car, owing to its simplicity and dependability, as well as the fact that it is self-contained. There is no difficulty in starting on a good magneto.

#### CARS THAT FINISHED IN THE 1905 VANDERBILT.

Editor THE AUTOMOBILE:

[1,428.]—Please inform me the makes of cars that were classified from first to fifth in the 1905 Vanderbilt Cup race.

Brooklyn, N. Y.

READER.

Hemery, in a Darracq, was first; Heath, in a Panhard, second; Tracy, in a Locomobile, third; Lancia, in a Fiat, fourth, and Szisz, in a Renault, had completed the ninth round when the race was officially declared off, owing to the crowd getting out on the course, so that only four cars finished.

#### SCALE GREATLY LOWERS RADIATOR EFFICIENCY.

Editor THE AUTOMOBILE:

[1,429.]—In reference to letter in "Letters Interesting and Instructive," No. 1378, from M. B. Hauser, Portland, Pa., beg to say that I think that perhaps the difficulty lies in the fact that the radiator of this correspondent's machine, and possibly the water jacket also, have become coated with "scale." Every one knows that all water contains a certain amount of mineral matter, and sometimes some portion of acid, and that all steam boilers have to be treated with a compound to prevent the pitting of the acid and to prevent scale. While water in a radiator does not necessarily boil, there is nevertheless considerable evaporation, and scale will form. I am using a compound which, I might say, was "invented" by a friend who is an expert engineer, and whereas before upon draining the radiator the water was discolored or red from rust, since using this compound it is always clear as crystal. There is absolutely no overheating, even when

running the engine at high speed for quite some time. The compound is absolutely harmless, will not injure the metal in the slightest, and is much to be preferred to caustic soda or hydrochloric acid, inasmuch as it can and should be left in the machine at all times. About one tablespoonful of the powder is used to the quantity of water contained in the radiator, and, therefore, a pound or two, which would cost about 50 cents, would last an average motorist an entire season.

I have no doubt that many of your readers will be interested in this matter and that they would obtain much better results if they would use something of this nature to keep the cooling system free from dirt and scale. If Mr. Hauser will try some remedy to free his radiator and engine from scale I believe that he will experience very little trouble. Many people are not aware of the fact that so small a deposit as one-hundredth of an inch of scale will very seriously affect the cooling system, as scale is a non-conductor of heat, consequently the air has practically no opportunity of cooling the water as it becomes heated.

Sharon Hill, Pa.

W. S. HAGAMAN.

#### IN SUPPORT OF INTERNAL PROTECTORS.

Editor THE AUTOMOBILE:

[1,430.]—In a reply to a letter published in "The Automobile," No. 1,405, written by H. C. Cresley, relative to his experience with internal tire protectors, we wish to say a few words.

In the first place, we know of no such party as H. C. Cresley, who claims to have had a pair of our protectors size 36x3 1-2 in two Michelin shoes, on the front wheels of his car, who states that in the very short distance of fifty miles, that the discs in the protectors worked loose and ruined the shoes and tubes. We can account for every 36x3 1-2-inch protector that has been placed on the market in this territory, and we know that none have been placed in the hands of the above-named party. Further than this, we have traced down every protector of this size that has been sold, and find that they have all been giving the very best of satisfaction.

The only circumstances under which a protector could go wrong would be in a case of defective workmanship, and in the manufacture of tires and tire equipment, no matter how carefully the output is supervised, occasionally some defective stock gets through, but we stand ready to replace anything that should prove defective, upon its being submitted to us for our inspection. If the facts had been as Mr. Cresley outlines, the logical thing would have been for him to have returned them to us, and demand an explanation as to why they acted in this way, as we fully guarantee them not to work loose.

These protectors are made to prevent punctures, and they do so without in any way injuring the casing and tube. If any one desires any information on this subject, we will take pleasure in referring them to many users who have had them in service for thousands of miles and who can recommend them highly.

WYATT & LISTMAN,

H. E. LISTMAN, Manager.

#### ABOUT THAT CYLINDER GRINDING PROJECT.

Editor THE AUTOMOBILE:

[1,431.]—I notice Mr. Sparenberg's answer to Mr. V. R. Lane in your issue of May 28, letter No. 1387. The trouble that anybody ever had with a gas engine will be but child's play if Mr. Lane fits his pistons according to Mr. Sparenberg's instructions and makes them tight-fitting for the cylinder. The regular practice is to grind the pistons conical, making them from about .008 of an inch smaller at the top than the bore of the cylinder, and about .005 of an inch smaller at the bottom. It does not matter much, within certain limits, how loose the piston is in the cylinder provided the rings are properly fitted, but if the piston is fitted in a gas engine cylinder in the same way that steam engine pistons are fitted, the piston will surely expand and stick in the cylinder. In engines intended for racing cars, or any continuous high speed work, the above allowances should be increased at least one-third.

E. T. BIRDALL.

Rochester, N. Y.

#### A ROAD TEST OF THE COAL-BURNING STEAMER.

Editor THE AUTOMOBILE:

[1,432.]—I took my coal burner, steel tired, no differential-on-drive axle, out Saturday morning to see if all was tight, before I painted it. It acted as I expected it would. I went up a steep grade at a 25-mile gait. In turning around and backing up the drive axle acted fine. It does not make near the noise that other gasoline cars make. A D. & H. engineer saw me go up the hill and he states that I made a 90-mile gait. With 150-pound boiler pressure it will climb any hill that a rubber tire will do; the White steamer carries 500 pounds steam pressure. I ran the car across the shop floor back and forth with two pounds pressure.

Oneonta, N. Y.

M. W. HAZLETON.

## RECENT ACCOMPLISHMENTS OF THE AIR PILOTS

ROME, June 10.—Fifteen minutes 25 seconds have been spent in the air by Leon Delagrangé, the French aeronaut, mounted on his Voisin flying machine. The exhibition, which proved to be a world's record, took place on the Place d'Armes before 6 A. M. before a large concourse of people and many members of the aeronautical societies of France, Italy and America; among the latter was Cortland Field Bishop.

After the ground had been carefully measured out, Delagrangé gave the order to start up the motor. A couple of men seized the big propeller, swung it round briskly, and a second later the eight-cylinder Antoinette engine was humming merrily. After two minutes on the ground the apparatus rose in to the air to a height of two or three yards and commenced a huge circular movement. Ten rounds were covered, the height slightly varying, but never falling below one yard from the ground. When fifteen minutes had passed Delagrangé was still aloft soaring through the air as perfectly as the moment he left the ground. Twenty-five seconds later, to the wild cheers of the enthusiastic spectators, the apparatus gradually came to earth,

to be competed for although a flight of a quarter of an hour is officially accomplished. At the Buc grounds near Versailles, at Trappes, near Paris, or on the Issy-les-Moulineaux ground under very strict police control, it is possible that Delagrangé or Farman will make an attempt to win the Armengaud prize immediately on their return from abroad.

### Farman Carries Passenger and Wins \$1,200 Bet.

Ghent, Belgium, June 10.—While his friend and rival Delagrangé was creating a world's record at Rome, Farman was busy on a unique performance in the neighborhood of Ghent. A few months ago a bet was made by Ferdinand Charron with Farman, Santos-Dumont and Archdeacon, that an aeroplane would not cover a kilometer with two men on board within a period of one year. Charron has lost his \$1,200, for just outside the old Flemish city Farman traveled 1,241 meters (1,356 yards) with M. Archdeacon on board his apparatus. The flight might have been longer had the length of the ground permitted an extension of the trip in a straight line.

Henry Farman's flight of 1,356 yards with Ernest Archdeacon as passenger, has been officially accepted by the Aero Club of France as the record for heavier-than-air machines with two persons on board. According to the report of the commission, the apparatus covered the distance without once touching the ground, the distance from the earth at certain moments being 26 feet. As soon as the aeroplane came to earth at the extremity of the field, the ground was measured by means of surveyors' instruments. To prevent any possibility of error, members of the commission were placed along the ground to be covered at distances of 200 yards, and an automobile carrying committeemen followed the flying machine.

### Wrights Make Preparations for European Tests.

PARIS, June 10.—At last France is to know the truth about the Wright brothers. Wilbur Wright is now here and this week left for Nates with his apparatus packed in cases. Within two months, according to the promise of the Parisian agent of the brothers from Dayton, the American aeronauts will have made a public demonstration and proven to the world that they are the champions of the upper regions. Meanwhile French aeronauts remain skeptical.

The Wright brothers are well known in Paris, having spent a considerable amount of time here last year, watching the French experiments and visiting the various aeronautical shops. There is a disinclination to put them down as bluffers, nevertheless a strong feeling prevails that they have not accomplished all they claim. French aeronauts have arrived so gradually at the results achieved that the public refuse to believe that the Wright brothers have accomplished more in a very much shorter space of time. Delagrangé having covered 7.8 miles in fifteen minutes and Farman having traveled nearly a mile in his apparatus with one passenger on board, Parisians are confident that their champions are now ahead of the two Ohio brothers.

There is no doubt whatever that preparations are being made for a flight, for the machine has been shipped under cover to the western town and Wilbur Wright has obtained permission from the authorities to use a large tract of plain for his experiments. The ground chosen has an area of 130 acres entirely without trees and protected by surrounding hills from eastern, northerly and western winds. As an aeronautical training ground the spot is perfect. An order has been given to a local builder to erect a shed 50 feet long by 30 feet wide and to lay down rails on which the apparatus will run to attain speed for rising from the ground.

The flying machine, which is now at the Chateau de Fonpietan, the residence of M. de la Reinty, a Frenchman interested in the American aeronauts, will be assembled in about ten days and flights made early in July.

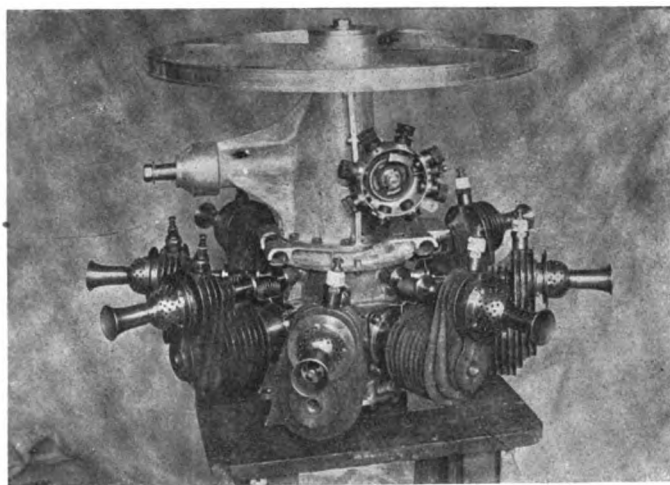

**Farcot Air-cooled Eight-cylinder Airship Motor.**

The cylinders are ranged about a common center as shown, there being but a single crankthrow, to which all the connecting rods are attached. Power is taken from the shaft shown extending at right angles. Automatic inlet valves are employed. The motor is rated at 35-horsepower and is extremely light.

the Italian prize for a flight of a quarter of an hour having been clearly and fairly won. Delagrangé had gained \$8,000 by his morning's flight of 7.8 miles.

Later in the morning, before the French ambassador and a number of the members of the Court, Delagrangé attempted to repeat the experiment, but owing to the force of the wind was obliged to abandon the attempt.

On the following Monday, while giving a final performance before the Queen Mother and a large crowd of spectators, Delagrangé met with a slight accident. After completing a round the apparatus got out of its course and threatened to collide with a stack of wood. In order to avoid a collision the aeronaut operated his rudders with such brusqueness that he brought the machine down to earth, a distance of about four yards, with a run. Delagrangé was fortunately uninjured, and the damage to his machine was only of a trifling nature, easily repaired by a few hours in the aeroplane workshop.

By his performance at Rome Delagrangé is entitled to the \$8,000 prize offered by the Societe Aeronautique Italiano, but has not won the Armengaud \$2,000 prize for a flight of fifteen minutes. The regulations for this event declare that the flight must be made on French soil and before three members of the commission appointed by the donator. Thus this prize still remains

# Across Pennsylvania in a Runabout

By Louis P. Reeder

FROM Meadville to Philadelphia, and from the Quaker stronghold to New York is a trip we accomplished in a 75-horsepower runabout. Meadville being on the north-west corner of Pennsylvania, near the Ohio line, our run was a diagonal one across the State, following generally the line of the Philadelphia and Erie Railroad. The party consisted of my wife, her sister and myself, the machine to accommodate us being a three-seated runabout with its extra seat on the left running board. This arrangement I believe to be better than the rumble seat behind, and it is certainly more sociable. Before starting out I looked the car over carefully and in my desire not to be unprovided added a stock of tools sufficient to rebuild the car if necessary, so it seemed. After all the precautions, however, I made the mistake of not carrying enough spare inner tubes and shoes, having only one of each.

We left Meadville about 10 o'clock of as fine an October morning as it would be possible to imagine, when autumn coloring was at its best. We headed for Warren, about sixty miles away, with no schedule to make, and the freedom to stay on the road two weeks or one, just as we pleased.

Our troubles commenced about ten miles from Meadville with a slipping clutch. Of course Fuller's earth was one of the things I had not placed in the trouble box, and not one of the drug stores we passed on the way to Warren could supply it. However, one store gave us some crocus martus which helped us on to Warren, where we got the necessary Fuller's and the can to apply it. Arriving at the Carver House, lunch was duly appreciated, for we



had had rather rough and hilly roads thus far, though better than those found later.

At 2:30 we were on the road again, heading for Kane, thirty miles, the entire distance up hill. Kane is claimed to be the highest town in the State. The first two miles of the road out of Warren were along the north side of a mountain and were about hub deep in gravelly mud; it was rough going, but it would have been rougher had it been clay. There is a better road on the other side of the river, via Glade, but repairs on the bridge at the latter place put it temporarily out of use and so compelled us to take the south side of the river. We struggled through without chains, however, and had fair roads and fine scenery the balance of the way to Kane. The country is thinly inhabited and scenes of abandoned timber operations were frequently passed, giving it a singularly desolate appearance. Kane has no garage, but a livery stable keeper allowed me to

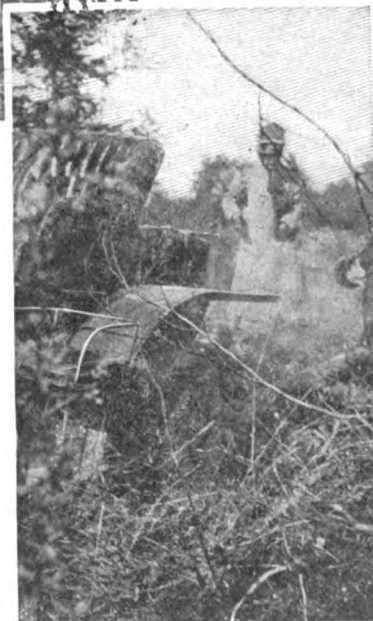

run the car in his barn over night, though he would not wash it for any consideration. We found a political demonstration under way at the

New Fleming, our hotel for the night, but in spite of the crowd managed to secure good accommodations. Our baggage, which was carried on a rack on the rear of the car, was a mass of mud, but it was partially protected by an oilcloth and the mud and water had not soaked through the trunk walls.

The next morning, rain. However, it gradually turned into a light drizzle and I got the car out. I flushed out the cylinders with kerosene and located the cause of the slipping clutch. The drip pan on the car lies up close to the flywheel. The drain pipe from the pan had become stopped with mud and oil which had collected in sufficient quantity to splash up on the leather-faced cone clutch enough to make it slip. I had no further trouble after cleaning the pan.

I got the hotel porter to wash out the radiator with his hose. It was practically solid with mud and had caused the motor to steam during the last few miles the previous afternoon. My own experience shows me that the cooling system on a high-power six-cylinder car must be kept in perfect condition to give satisfaction. Of course this is the case with cooling systems on all motors, but I believe the cooling system on a four-cylinder motor will stand more abuse than one on a six. I have to keep the fan belt pretty taut to cool under hard work, and I believe a gear-driven fan, provided it can be run quietly, is preferable.

### A Genuine Friend of the Automobilist.

We intended to make Lock Haven that evening, but it took us two days to reach that point instead of one. Since Kane is at the top of the ridge, our road was in general a long down grade through Ridgeway to Emporium. These towns are about twenty-five miles apart, as I recollect the distance, and about midway between the towns the road would gradually fade away to a mere lumber trail overgrown with grass and bushes; but as we neared town again it gradually grew better until a few miles before entering Emporium we ran on to a new and excellent State road. We took lunch at Emporium, and I afterward made some inquiries concerning the roads through Driftwood to Lock Haven. I had supposed there must be some sort of carriage road down the valley through which ran the Pennsylvania and Erie Railroad, but found I was mistaken. It appears there is nothing

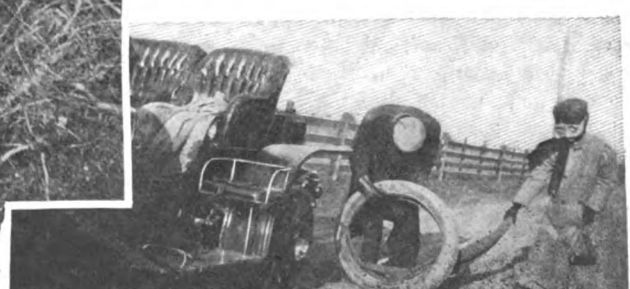



beyond a trail through the woods from a few miles below Emporium. I eventually met a Mr. Brady who put me right. Now, this Mr. Brady is a man to look out for; he will load you up with oil and gasoline and anything you haven't got, and won't take anything for it but thanks, and is even shy about that. Mr. Brady informed me that I had better turn northeast to Coudersport, twenty-five or thirty miles (provided you don't lose your way) and then turn south to Lock Haven. This good Samaritan wound up by showing us the way out of town for seven miles and then gave us careful directions for the rest of the road to Coudersport. That's the kind of an automobile fiend it is a pleasure to meet, May his tribe increase!

The roads were fair for a time and I anticipated no trouble in reaching Coudersport; but it gradually grew rougher, and when it seemed likely to fade away entirely I asked a few questions of the natives to get my bearings. The hills in this region are steep and to get over them it is necessary to resort to the "switchback" road, which zigzags up the side of a mountain at a good stiff grade with some mighty short turns at the angles, especially short for a 122-inch wheelbase car. These roads are not frequently met in general touring, however, and I believe the long wheelbase has advantages which compensate for the disadvantage just mentioned. When we ran into Coudersport and made inquiry we were told there was no passable road south, but must continue to Galeton, twenty-five miles further east. The road was very rough and we did not pull into Galeton until about 6 o'clock in the evening, by which time it was already dark and the arc-lighted sawmills just at the western end of the town gave Galeton a very spectacular appearance. During the last ten miles I had some magneto trouble owing to my having dashed water on the radiator to clean it a little, while the motor was running, the consequence being a wet magneto.

#### This Road Last Repaired Fifty Years Ago.

We found a good hotel, of which I have forgotten the name, but no garage, and again I had to run the machine under a shed. I drew off the water to prevent freezing, and it was a precaution well taken, as it was far below freezing the following morning. I was informed by several people that even now I could not turn south, as the road, the old Coudersport Pike, was built seventy years ago, had not been repaired for fifty, and I had better continue east to Wellsboro before making a turn for the south and the west branch of the Susquehanna. I finally met a man who had driven with a horse and carriage through this road to Lock Haven the preceding summer, and he advised me that by careful driving I could make it. A company of U. S. infantry had been through the year before, and had repaired the bridges enough to let a wagon train through.

I decided to take the pike route, and in the morning we started for Germania, eleven miles, all up hill, then down to Oleona, the scene of Ole Bull's colonization scheme. Apparently nothing remains of the town but a house and barn and some ruins.

The road from this point on to Lock Haven is practically forty miles of wilderness. It climbs to the top of a ridge and follows it for miles. I believe we could see across thirty miles of other ridges east and west, all in their fullest autumn glory. The road was fair in spots, but a great deal of it was rotten corduroy. The corduroy road was built with logs of a pretty good size and where all the soil was gone from the top it is needless to state that riding over that particular road was no joke. About noon I carelessly ran too close to the edge of the road; the rotten ends of the logs gave way and dropped my left rear wheel sufficient to let the tool box and differential casing rest on the ground. The car is heavy, and it took me over an hour to jack up the car and gather enough stones to make a foundation to run out on. We passed Pumping Station, consisting of four families and an equal number of oil tanks.

The road through this section is very narrow and badly washed, usually taking the form of a ditch, or trench, two to six feet deep, and just wide enough for the car to scrape through. The road being closely overhung with scrub and undergrowth of

all kinds, our faces were pretty well whipped and scratched. At length, in the afternoon, we descended a long hill, remarkable for the number and size of its waterbreaks, to Lock Haven, on the West Branch. From this point on we were at least sure of traveled roads and a settled country. I ran the car into a garage for a washing, the first since leaving Meadville. It rained that night and the following morning, but at noon the weather cleared a bit and we decided to start for Williamsport. Of course our starting was the signal for a heavier downpour than ever. It took two hours to run the twenty-five miles. The roads were the usual "soft soap" variety, and it was impossible to hold the machine. We were in the ditch several times, in spite of chains. I carried another friend with us to Williamsport. Our chains broke and he was well initiated into the pleasures of automobiling by the time we arrived, soaked through. However, we found an excellent hotel, and an equally good garage. We stayed over the next day to give the roads an opportunity to dry up a little, and I improved the leisure to have the machine cleaned and a leaky radiator soldered, the twisting received over the mountains having started a slight leak.

#### Tire Trouble—but the Tires Were Not to Blame.

Up to this point I had no tire trouble, but we got it on the run to Harrisburg the following day. I mistook a small blowout for a puncture, put in my only spare tube without a careful examination, and in consequence had another blowout, a big one this time, in a couple of miles. I then patched the first tube as well as possible but it gave out in five miles. I ran on the flat shoe until it ran off, then tied it on with rope. The shoe finally cut in two and I ran three or four miles on the bare rim to Clark's Ferry.

We were only eighteen miles from Harrisburg, and I sent word in by a passing machine to send out a new tire or at least a machine to take us into town, but, though I afterwards found the garage was notified, for some reason they did not have energy enough to start out a machine for us. We waited from 5 P.M. until 10 P.M. and took the train for Harrisburg, dead tired. I got a blowout patch and a new tube the next morning and brought the machine to town. It was necessary to borrow a couple of crowbars from the section hands on the railroad nearby to straighten out the rim, which we had rolled down by running on it bare.

We finished the trip to New York over the well-known route from Harrisburg, via Philadelphia, without further incident other than blowing out two more tires. Being in a civilized country by this time we were able to get tires promptly and proceed.

I had put an extra gallon each of oil and gasoline in the tool case on the rack in the rear, but the cans were punctured and the oil and gasoline distributed over the tools before we had completed half the trip. We enjoyed the trip thoroughly, though there are some few incidents more pleasant in the recollection than the participation, such as the five-hour wait for a train at Clark's Ferry. The thirty or forty pounds of extra tools could have been profitably replaced by some Fuller's earth and a few spare tubes.

#### THINK VISITORS SHOULD BE EXEMPT.

BALTIMORE, Md., June 8.—Local autoists are of the opinion that autoists from other cities should be allowed to pass through the State of Maryland without having to procure a Maryland license. They have, also, urged that the Maryland law be changed so that the visitors may be permitted to remain in this State unmolested for 24 hours. Under the present law visitors are required to obtain a Maryland license before they bring their car into the State. This has resulted in the arrest recently of many visitors, who have been fined \$1 and costs, for not having Maryland licenses. The local autoists believe that an arrangement should be made here so that visitors could enter the State and get licenses at court houses in any of the cities and towns of the State, instead of having to obtain these licenses before entering Maryland, from the officials at Annapolis.

### PRINCE EDWARD ISLANDERS FIGHT LAW.

CHARLOTTETOWN, P. E. I., June 15.—Automobile owners of this city have held a conference and have decided to test the validity of the recent act of the Provincial legislature authorizing counties and municipalities to bar automobiles from the roads, many of the counties and towns already having done so, Charlottetown being among the number. A circular has



Riding Out to Defy a Medieval Law.

been issued calling attention to the fact that a franchise was granted to a company to run motor vehicles as far back as 1902, and in 1906 a second was issued to run trackless trolley cars, neither of these acts having met with any protest. They further point out that as no indemnity has been provided for by the recent act, the machines owned in the Province will be a dead loss. The accompanying photograph shows the opening of the test case, the car being run through Charlottetown's streets on one of the forbidden days, so that the hour's ride may cost the participants a \$500 fine or six months in jail, if the act be upheld. W. K. Rogers is driving the car, Bruce Stewart is beside him, while the occupants of the tonneau are J. A. S. Bayer, Dr. Allen and George E. Auld.

### NEW ORLEANS WANTS AUTO SHOW.

NEW ORLEANS, June 1.—"An automobile show for New Orleans and the South this fall" is the slogan of local automobile dealers and enthusiasts. The plan has been talked over by the local dealers for some time, and while the plans are still in their infancy, still the prospects are good. The automobile dealers of this city and the South have been quick to take up with the favorable public sentiment that has been created by the good roads proposition and also the success of the Savannah races and will use it to still further advantage. They argue that the time is now ripe for a Southern automobile show to be held here in the metropolis of the South.

The South is being recognized more and more as one of the most fertile fields for the automobile industry, were it but fostered and cultivated. Those who are at the head of the movement for the show are meeting with great encouragement from all over the South and from the various manufacturers themselves.

The opening of the Legislature at Baton Rouge sees the Louisiana Automobile League hard at work. They have established a lobby there, which will work for the advancement of the good roads proposition and also look after the interests of the automobilists. The lobby is composed of good, careful men and it will be conducted in a clean, above-board manner. It is hoped to get the Legislature to build a shell road from Baton Rouge to New Orleans, a distance of about one hundred miles. This road is to follow the Mississippi river and will be one of the most picturesque in the South.

### BALTIMORE TRIES OUT DUST LAYERS.

BALTIMORE, June 8.—An experiment is being tried here which promises to do away with the dust nuisance during the coming summer on the highways traversed extensively by autoists in going to and from the city. This dust preventive, intended chiefly for macadam roads, is called terracolio, a bitumen compound. The experiment has been conducted by Commissioner of Street Cleaning Wickes, on Park Heights avenue, back of Druid Hill Park, which is the most popular thoroughfare in and around the city for motorists, and he declares that the results have been quite satisfactory. The material is black and resembles pitch. It is mixed with water in the road sprinklers. The road has shown no effects from its application, except for the absence of dust. The mixture was first applied at a strength of an 18 per cent. solution with water. This solution will be reduced gradually until a 2 per cent. solution will be used permanently.

### AUTO FIRE APPARATUS FOR SPRINGFIELD.

SPRINGFIELD, MASS., June 15.—Automobile fire apparatus is very popular in this city as will be shown by the recent action of the city council's finance committee in recommending that two more motor power wagons be added to the present automobile equipment. One wagon is to be a combination hose and chemical truck, the other to be a regular hose wagon. These wagons are to be put in the Chestnut street engine house, which will be an automobile station only. There is at present a flying squadron stationed there, the wagon being a Knox type. It is estimated that the wagons will cost about \$3,000 each. The committee also recommended that another automobile patrol wagon be built for the police department, the style of which has not been decided upon.

### COMMISSIONER MACDONALD'S NEW AUTO.

HARTFORD, CONN., June 15.—Highway Commissioner James H. MacDonald, of Connecticut, is not only one of the most able and persistent advocates of the cause of good roads, but he realizes better than probably anyone else in a similar position the value of the automobile for his use. In the accompanying photograph he is shown in the new Pope-Hartford car recently delivered to him by the Pope Manufacturing Company. It is finished in a light mahogany brown with black enamel trimmings and has a number of special devices on it not often found on the average touring car. There is a special

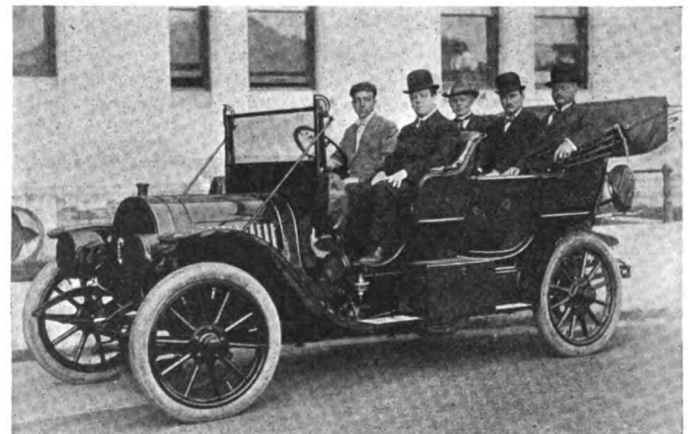

Specially Equipped Pope-Hartford Road Car.

rack made to accommodate a typewriter and a stenographer will accompany the commissioner on all his runs. There is also a special type of gradometer and a most complete system of electric lighting. The State seal on the doors adds to its imposing appearance. With the aid of his new car Commissioner MacDonald will be able to cover many times the territory and increase his scope of usefulness to Connecticut's progressive good roads campaign which is now in full swing throughout the State.

**FAUBER PERFECTS HYDROPLANE.**

PARIS, June 3.—What is probably the first attempt in Europe to present the hydroplane as a comfortable cruising craft is due to an American inventor, W. H. Fauber, who is still well known in the States by reason of his connection with the cycle industry, and his proprietorship of the Fauber Manufacturing Company, at Chicago. He has been working for a couple of years on an improved type of hydroplane and has now so far perfected his models that he has made arrangements for the building of his craft for the public.

The Fauber hydroplane, which would have taken part in the Monaco meet but for delays in the issuing of patents, has undergone its trial trips in the Seine at Nanterre, near Paris, and has covered the measured kilometer in 60 seconds dead, which is at the rate of nearly 38 miles an hour. With some slight improvements in lines and propeller, it is believed by Fauber that he can carry the speed to rather more than 40 miles an hour.

Distinctive in the Fauber hydroplane is the fact that when at rest in the water it has all the lines of a graceful displacement boat. Its sharp bow cuts the water clean and its special type of hydroplanes, about which the inventor does not wish to be communicative, assure it a stability that has been totally lacking in this class of boat up to the present. Fauber is so well pleased



Fauber's Hydroplane at High Speed.

with the results obtained in his racing craft, which he claims to be faster and capable of operating on rougher water than any other hydroplane yet built, that he has made arrangements for the construction of a series of 21-foot boats to be fitted with a four-cylinder engine and used as pleasure cruisers. A 26-foot racer which will embody all the improvements suggested by the present racer is also under construction and will be tried out on the Seine during the summer. The Fauber racing boats are equipped with eight-cylinder Antoinette light-weight engines of 50 horsepower.

**THE CARRIAGE WAITS "WITHOUT," MY LORD!**

"The carriage waits without, my lord."  
 "Without what, gentle sir?"  
 "Without the left-hand running-board,  
 Without the French chauffeur,  
 Without a drop of gasoline,  
 Six nuts, the can of oil,  
 Four pinions, and the limousine,  
 The spark-plug, and the coil;  
 Without the brake, the horn, the clutch,  
 Without the running-gear,  
 One cylinder—it beats the Dutch  
 How much there isn't here!  
 The car has been repaired, in fact,  
 And you should be right glad  
 To find that this much is intact  
 Of what your lordship had.  
 The garage sent it back, my lord,  
 In perfect shape throughout;  
 So you will understand, my lord,  
 Your carriage waits without."  
 —"Harvard Lampoon."

**THE AUTOMOBILE CALENDAR.  
 AMERICAN.**

**Shows and Meetings.**

- June 25-27.....—Detroit, Third Annual Summer Meeting of Society of Automobile Engineers.
- Dec. 31-Jan. 7.....—New York City, Grand Central Palace, Ninth Annual Automobile Show, conducted by the American Motor Car Manufacturers' Association, with Exhibits by the Importers' Automobile Salon, Inc., Alfred Reeves, general manager, 29 West 42d St.
- Jan. 16-23.....—New York City, Madison Square Garden, Ninth Annual National Show of the Association of Licensed Automobile Manufacturers. (Exact date to be announced.)
- February, 1909. —Chicago Coliseum and First Regiment Armory, Eighth Annual National Exhibition, National Association of Automobile Manufacturers.. (Exact date to be announced.)

**Races, Hill-climbs, etc.**

- June 20-26.....—Albany, N. Y., Annual Five-day Tour of the Albany Automobile Club.
- June 24-27.....—New York and Philadelphia, Double-Head Endurance Run to Delaware Water Gap, under the auspices of the "Public Ledger" of Philadelphia.
- June 24-27.....—Chicago, 1,200-mile Reliability Run, Chicago Motor Club.
- June 27.....—Norristown, Pa., Skippack Hill Climb, Norristown Automobile Club.
- July 4.....—Long Branch, N. J., Race Meet, Elkwood Park Automobile Association.
- July 4.....—Lowell, Mass., 250-mile Road Race, Lowell Automobile Club.
- July 4.....—Wildwood-by-the-Sea, N. J., Annual Speed Tournament, Motor Club of Wildwood.
- July 7-8.....—Buffalo, N. Y., National Convention of the American Automobile Association.
- July 9.....—Buffalo, N. Y., Start of the Fifth Annual A. A. A. Reliability Touring Contest.
- Aug. 14.....—Chicago, Third Annual Algonquin Hill Climb, Chicago Motor Club.
- Sept. 5-9.....—San Francisco-Los Angeles Reliability Run, Automobile Dealers' Association of San Francisco.
- Sept. 14.....—Chicago, Annual Economy Run, Chicago Motor Club.
- Oct. 24.....—Vanderbilt Cup Race, Long Island Course, auspices of Vanderbilt Cup Commission.

**FOREIGN.**

**Shows.**

- Oct. 11-18.....—Paris, International Congress and Public Exhibition on Roads and Road Making for Modern Locomotion, French Ministry of Public Works.
- December.....—Paris, Eleventh Annual Salon de l'Automobile, Grand Palais, Automobile Club of France.

**Race Meets, Hill-climbs, etc.**

- July 6.....—Voiturette Grand Prix, Dieppe Circuit (Automobile Club of France.)
- July 7.....—Grand Prix of Automobile Club of France, Dieppe Circuit.
- July 13-17.....—Ostend, Belgium, International Race Week, Automobile Club of Ostend.
- Aug. 12.....—Ardennes Circuit Races and Coupe de Liedekerke, Automobile Club of Belgium.
- August.....—France, Coupe de la Presse, Automobile Club of France. (Exact date to be announced.)
- Aug. 29-30.....—France, Mont Ventoux Hill Climb, Vauclusien Automobile Club.
- Sept. 1-8.....—French Voiturette Contest, Auspices "L'Auto."
- Sept. 6.....—Bologne, Italy, Florio Cup Race, Automobile Club of Bologne.
- September.....—Paris, Vichy Aeroplane Competition, \$4,000 Prizes, Aero Club of France.
- Oct. 11.....—Berlin, Germany, Gordon Bennett Balloon Race, Aeronautical Club of Berlin.

Summit, N. J., is the latest town in the State across the Hudson to work a speed trap. The trap itself is actually in New Providence, which is only a name, and on Springfield avenue, west of the West Summit station. It is located where a road crosses Springfield avenue diagonally from the northeast, and the presence of the crossing is considered sufficient excuse to compel autoists to slow down, or rather to be trapped because they do not do so, under the clause in the law requiring a speed of fifteen miles an hour "at prominent intersections."

## HIGH PERCENTAGE IN FRENCH COMMERCIAL TEST

PARIS, June 10.—It is somewhat embarrassing to pick out the winners in the industrial vehicle competition that the Automobile Club of France has just brought to a close after one month's traveling in the north and west of France, for the cars are so closely grouped that all might be considered victors. A fuel consumption test on the last stage of the journey can hardly be taken as conclusive, all kinds of fuel being allowed, and thus, by reason of differences in price arbitrarily dividing up vehicles that were otherwise on an equal footing.

Thirty-five industrial vehicles, from light-weight delivery vans to 5-ton trucks left Paris a month ago. Of this number twenty-four have entered the capital under official recognition, having changed nothing more important than spark plugs, valve springs, etc.; in a word, with the mere exchange of such parts as are always carried on any long-distance touring car. In addition to motor transmission and all running gear, tires and wheels, hitherto the weakest part of heavy trucks, were sealed and came back to Paris on the victorious twenty-four. A small number finished the run and made all controls on time but were disqualified for slight accidents to machinery which could be repaired on the road, but necessitated the changing of some sealed part. Thus, a front-drive truck burned out the bearing of one of its rear wheels free from all driving mechanism. The repair necessitated taking off the wheel and entailed disqualification although all other conditions were filled. In the same way another truck was obliged to retire from official observation by reason of one of its rubber blocks having to be changed.

In the cab competition two out of the eleven vehicles had to withdraw owing to the changing of sealed parts. The nine others made all controls on time and returned to Paris after a month's traveling with every part intact. The net result is surprising, 68.5 per cent. clean scorers in the truck classes and 82 per cent. in the cab section, under rigorous rules, being a proportion never attained in any previous competition.

It might be objected that the cab competition was not so thorough as that for the commercial vehicles, the long straight-away runs that had to be made over roads that were excellent on the whole not being so trying to the mechanism as a varied service in crowded city streets often badly paved and ill kept. For the trucks the competition was harder than actual working conditions, the full load having to be carried continuously, whereas under commercial conditions there is a certain proportion of running light. One reason for the great success of the vehicles is the fact that speeding with the heavy trucks was eliminated by a system of frequent controls. A commercial speed was demanded and insisted upon, thus at the same time proving the qualities of those vehicles suited for heavy transport and preventing premature wrecking of machines.

The official classification was made on a fuel consumption test of 69.6 miles over various roads not sufficiently hilly, however, to allow the vehicles to do any coasting. The formula

employed was  $\frac{TC}{PD}$ , in which  $T$  was time in hours,  $C$  cost of fuel

in francs,  $D$  distance covered and  $P$  the total weight. As the fuels allowed were the following, gasoline at 40 francs 50 per hecolitre, white spirit at 27 francs 75, carbureted alcohol at 33 francs 70, and benzol at 24 francs 65, the users of gasoline were naturally handicapped. The cabs were on an equal basis in this respect, all having to run on alcohol for the entire distance; speed limited to 20 miles an hour, there was in reality a slight advantage to low-powered single and two-cylinders.

Under the general classification first prize goes to a Saurer truck, manufactured by the well-known Swiss firm at Arbon. With a useful load of three tons and a total weight of six tons, the Swiss truck covered the 691.2 miles on 4.4 gallons of white spirit. Second position fell to a little single-cylinder De Dion of 3.9 bore by 4.7 stroke which, despite its small power plant, carried a load of one ton and a half for an entire month without any signs of weakness. The third prize went to a Saurer passenger 'bus in the class for more than ten people, fourth to a light delivery Panhard, and fifth to a 3-ton Saurer. Though it permitted of a complete classification, the fuel test tended to make confusion, for it arbitrarily divided vehicles that were otherwise equal. Those eligible for and taking part in this final test comprised 4 Dietrichs, 3 Saurer, 3 Panhard, 2 Cohandet, 1 Vinot-Deguingand, and 1 Brohout, all of which had their full teams in at the end of the competition. Berliet presented 7 trucks, having lost one on the journey through a defective rubber bandage. De Dion was eligible to put in two of his three competing vehicles, and Peugeot had but one perfect scorer out of five starters.

Six of the perfect scorers are eligible for purchase by the army, having fulfilled all conditions set forth in the military regulations. The trucks comprise two Berliet, two Cohandet, one Vinot-Deguingand and one Panhard. It remains for the constructors to arrange terms with the military authorities.

The fuel consumption test for the cabs gives first place to a two-cylinder Dorion-Flandrin, which consumed but 1.3 gallons of alcohol for a distance of 69.5 miles. A single-cylinder Brouhot made the same distance on 1.8 gallons. Bayard-Clément was the most economical of the four-cylinder cabs, as was proved by the consumption of 2.2 gallons for the same distance. The winning Dorion-Flandrin had at its power plant a 10-horsepower engine of 3.1 and 4.7 bore and stroke, Longuemare carbureter and Bosch high-tension magneto. The feature of the Brouhot which took second prize for fuel economy was a single-cylinder engine of 9-horsepower, bore being 4 inches and stroke 5.1. Unlike the others, transmission was by belt, completely enclosed to protect it from dirt and oil. This type of transmission, neglected for some time by constructors, is now gaining popularity among the makers of small pleasure and commercial vehicles and bids fair to be revived to a considerable extent.

## HEMERY CAPTURES ST. PETERSBURG-MOSCOW HONORS

MOSCOW, June 6.—Hemery, after lying quiet since his break away from the Darracq eight-cylinder flyer, has secured a notable victory by taking the first prize in the St. Petersburg-Moscow race, covering the 425 miles on his Grand Prix Benz in 8:30:48. Last year's record, made by Duray, has been beaten by 52 minutes. Second place was secured by Demogeot, driving the four-cylinder Darracq racers which Caillois handled in last year's Grand Prix. His time was 8:42:12. Third place in the high-powered class goes to the English driver Pope, handling an Itala. The cars in this class which failed to finish included

a full team of Dietrichs, a Fiat and a Mercedes. By winning this race on the actual machine which he will drive in the Grand Prix Hemery has enormously increased the esteem in which he is held by the public as one of the probable winners of the race on the Dieppe circuit. No other car built for the Grand Prix is sufficiently advanced to be able to start in a race five weeks before the French Automobile Derby.

Wagner has taken first prize in the second category reserved to cars not exceeding 130 millimeters bore, running the Fiat racer of last year from St. Petersburg to Moscow in 8:49:48.





Vol. XVIII

Thursday, June 18, 1908

No. 25

THE CLASS JOURNAL COMPANY

Flatiron Building, Madison Square  
New York City

H. M. SWETLAND, President

EDITORIAL DEPARTMENT

A. G. BATCHELDER, Managing Editor

R. F. KELSEY, Associate Editor C. B. HAYWARD, Engineering Editor  
W. F. BRADLEY, Foreign Representative

BUSINESS DEPARTMENT

A. B. SWETLAND, Business Manager

LOUIS R. SMITH FRANK B. BARNETT

W. I. RALPH, 1035 Old South Building, Boston, Mass.

C. H. GURNETT, H. E. WESTERDALE, 1200 Michigan Ave., Chicago, Ill.

Cable Address - - - - - Autoland, New York  
Long Distance Telephone - - - - - 300 Gramercy, New York

SUBSCRIPTION RATES:

United States and Mexico - - - - - One Year, \$3.00  
Other Countries in Postal Union, including Canada - - - - - One Year, 5.00  
To Subscribers—Do not send money by ordinary mail. Remit by Draft,  
Post-Office or Express Money Order, or Register your letter.

FOREIGN SUBSCRIPTION AGENTS:

ENGLAND:—W. H. Smith & Sons, Ltd., 186 Strand, London, W. C., and all their  
railroad bookstalls and agencies throughout Great Britain; also in Paris at  
248 Rue de Rivoli.  
FRANCE:—L. Baudry de Saunier, offices of "Omnia," 20 Rue Duret, Avenue de  
la Grande Armee, Paris.  
GERMANY:—A. Seydel Mohrenstrasse 9, Berlin.

Entered at New York, N. Y., as second-class matter.  
The Automobile is a consolidation of The Automobile (monthly) and the Motor  
Review (weekly), May, 1902, Dealer and Repairman (monthly), October, 1903,  
and the Automobile Magazine (monthly), July, 1907.

Copies printed in 1905	- - - - -	730,000
" " in 1906	- - - - -	791,000
" " in 1907	- - - - -	888,900

SHOWING UP BOTH SIDES OF THE CASE

Throughout all the host of accusations that have been hurled against the automobile as a destroyer of the roads, nothing whatever has been heard of the far worse activities in the same direction that the horse is responsible for, and that he has been responsible for since the dawn of history. By long association, we have grown so familiar with the damage done by the horse and wagon that we do not look upon it in this light. Consequently, those who most rabidly denounce the automobile as a road destroyer look upon the holes and ruts created by its slow-going predecessor as a perfectly legitimate form of wear and tear against which no objection can be raised. Of course, this is a prejudiced view, but then so are the majority of other objections raised against the power-driven vehicle. The automobile leaves a mighty cloud of dust in its wake passing along a country road, and, to say the least, this is annoying, but if it were not for the manner in which the horse and narrow-tired wagons pulverize the road surface there would be nothing like as much dust present, while the horse raises more than the auto, speed considered.

It is not to be contended for a moment that the automobile does no damage to the roads, but it is a fact easily demonstrated to the satisfaction of the most skeptical that at the speeds ordinarily averaged by automobiles the car is actually a road-improver rather than a destroyer.

There can be no denying the fact that above thirty miles an hour, the passage of the pneumatic tire creates considerable suction and tends to lift the top dressing, and in skidding round curves at speed the latter is forcibly removed to the outside of the curve, but by no stretch of the imagination can the automobile be truthfully accused of creating deep, narrow ruts or the numerous heavy "pock-marks" to be found on the best of road surfaces, and that are characteristic of the horse's passage. When the matter is considered impartially, it will be found that the horse is responsible for a far greater measure of damage than the automobile, and it is, moreover, of a nature not easily prevented or repaired. The use of an effective binder, properly applied, makes a road on which the automobile does little or no damage even at racing speeds, except on curves, and properly built roads will be free from even this, but the horse is a road-destroyer even when he is standing hitched. A little consideration of both sides of the question should do much to mold popular opinion to a more equitable view of the case.



ENTERING UPON A NEW ERA OF PRICES

Ever since the automobile assumed sufficient importance to demonstrate the fact that it had come to stay, and was not the fad of the moment, there have been an endless number of prophets, who, figuring by the precedent set by the bicycle, have been predicting the coming of the "poor man's automobile." When, after a number of years of steady development, a good bicycle could be purchased for \$50, it was really a machine that embodied far better material and workmanship than its predecessors that sold for three times as much. Merely because a great deal of thought and capital had been steadily devoted to its betterment. The past five years have brought forth corresponding advances in the case of the auto.

Whether there will ever be such a thing as the "poor man's automobile" has been discussed pro and con on several occasions in these columns and nothing that has happened in the interim can be considered as sufficient cause for altering opinions there set forth. But that the time has come when it will be possible for the man in ordinary circumstances to maintain an automobile that is neither a cheap, low-powered car or one that is merely a low-priced imitation of better things, has actually arrived, now appears to be a fact. Numerous American makers have brought forth extremely creditable productions in the shape of low-priced cars in past years, and the number of these machines that have been sold, as well as the service they have performed, forms an imposing record of their success. But, after all, few, if any, of these little machines satisfied the ambition of the newly fledged autoist for very long. As a stepping-stone to bigger and better things in the shape of a car, they served their purpose admirably, and proved an excellent initiation, but not every investor can afford to go through this process of education. The man with the low-priced car found it lacked many things, once his first pride of possession wore off. Judging from some of the new models recently announced, designers have had their eyes open to this state of affairs, and their productions reveal it in no uncertain manner. In fact, it seems safe to predict that the passing of 1908 will mark the beginning of a new era in automobile prices and values.

## BUFFALO CONVENTION IS OF NATIONAL IMPORTANCE

OFFICIAL recognition is being accorded on every hand of the importance of the Good Roads and Legislative Convention called by the American Automobile Association to meet at Buffalo, July 6, 7 and 8. Illustrative of this is the letter which is being sent out by State Engineer Skene, of New York, to the town boards and supervisors of 934 towns. It follows:

A National Good Roads Convention will be held in the City of Buffalo, July 6, 7 and 8, 1908. This will be the first National Good Roads Convention to be held in this country in which the several State highway officials, the farmers, as represented by the National and State granges; the motorists, as represented by the American Automobile Association, comprising over 200 clubs, and the Road Makers' Association, will cooperate.

One of the most important features of this convention will be the practical demonstration of highway maintenance and construction. Seventy-five miles of road will be in course of improvement and within easy access of the city of Buffalo, and about twelve miles of road will be used to demonstrate the several dust-laying and road-surfacing preservatives. This work will be under the direction of this department.

You are earnestly requested to be present and cooperate in making this convention as successful as possible.

FREDERICK SKENE,  
State Engineer and Surveyor.

Robert P. Hooper, Chairman of the A. A. A. Good Roads Committee, has requested similar letters to be sent out by the State highway commissioners of Michigan, New Jersey, Illinois and Massachusetts.

The speakers at the convention and their subjects will be: James H. McDonald, president American Road Makers, Hartford, Conn., "Construction of Macadam Roads"; Frederick Skene, State engineer and surveyor of New York, "History and Development of Improved Highways"; W. E. McClintock, highway commissioner, Massachusetts, "Repair and Maintenance of Macadam Roads"; Joseph W. Hunter, highway commissioner, Pennsylvania, "Road Materials"; A. N. Johnson, State engineer, Springfield, Ill., "Road Problem in the State of Illinois"; P. A. Hooker, supervisor of public roads, New Jersey, "Surfacing of Macadam Roads"; Horatio S. Earle, State highway commissioner, Detroit, Mich., "Drainage and Sub-base of Improved Roads"; L. W. Page, U. S. Department of Agriculture, Washington, D. C., "Effect of Automobiles on Macadam Roads, and Question of Preservation Under New Conditions"; D. Ward King, Missouri State Board of Agriculture, Maitland, Mo., "Treatment of Earth Roads"; Stephen Ryan, State Road Directory, New York, "Improvement of Town Roads."

Other speakers, whose subjects are yet to be announced, are: Ex-Governor Batchelder, of New Hampshire, president of the National Grange; Aaron Jones, master of Indiana State Grange, Indiana; F. A. Derthick, master of Ohio State Grange, Ohio; F. N. Godfrey, master of New York State Grange; Jothan P. Allds, senator, Highway Code, Norwich, N. Y.; R. B. Boman, deputy State highway commissioner, Pennsylvania.

## WHY EUROPE MISUNDERSTANDS RACING SITUATION

PARIS, June 10.—It is impossible to give a better idea of the gross ignorance of automobile Europe regarding American matters than by a textual translation of a portion of an article published in the semi-official organ of the Automobile Club of France. It reads as follows:

When the American Automobile Association sent its regulations for the Vanderbilt Cup we noted that they in no way conformed to those adopted at Ostend by the Federation of National Automobile Clubs. A few days later M. René de Knyff, president of the Sporting Commission of the Automobile Club of France, wrote a letter of protestation to the president of the Automobile Club of America. This letter was addressed to the A. C. A., the only automobile controlling power in America recognized by the A. C. of France.

The Automobile Club of America then requested the A. A. A. to adopt the Ostend regulations for its race. The A. A. A. refusing to give satisfaction to the Automobile Club of America, the club purely and simply disqualified the event and telegraphed this decision to all the clubs of the Federation asking that they should give their support. Each telegram was reply paid to the extent of 150 words.

Having information of this nature, it is not surprising that the Sporting Commission of the Automobile Club of France, at its special meeting this week, should have been of the opinion that the only course open for it was to support the Automobile Club of America, and, like that body, disqualify the Vanderbilt Cup.

In French eyes the matter is simplicity itself. The A. C. F. is under the impression that the Automobile Club of America is a body in every respect similar to itself. As everybody knows, the French Club is undoubtedly the club of France; its officers and leaders are the heads of such firms as Panhard, Renault, Brasier, Darracq, Dietrich, Bayard-Clément, Mors, Delaunay-Belleville, etc. The entire automobile industry of France is represented in the Automobile Club of France; there is no opposition; other bodies have been formed for specialized work, or are provincial clubs occupied entirely with local affairs.

It is no exaggeration to say that nine-tenths of the directors

of the Automobile Club of France are under the impression that a similar condition exists in the United States, and that the Automobile Club of America is its counterpart in the western republic. No other explanation is possible for its recent action in connection with the Vanderbilt Cup rules. So convinced are they that they are right that this recent decision to boycott the Vanderbilt and support the Grand Prix of America, which the A. C. A. may put on foot, has been communicated to all European bodies and their support earnestly solicited.

M. René de Knyff, president of the Racing Board of the A. C. F., is reported to have declared that he was very well pleased with the decision. "The Automobile Club of America is the only official organization in the United States and we are bound to support it in the attitude it has assumed towards the Automobile Association, which has flagrantly ignored the rules of the Ostend conference in promoting a contest not in accord with the agreements then made."

Count Adalbert Sierstorpf, the German representative, states that his club has written all German automobile manufacturers, advising them not to enter for the Vanderbilt Cup contest.

Doubtless the only way to straighten out the difficulty would be for the American Automobile Association to send a deputation to the international conference to be held at Dieppe during the French Grand Prix. At this meeting, which will be attended by delegates from all the European national clubs as well as the Paris representative of the A. C. A., the question will be fully discussed and no doubt an attempt made to get the international federation to vote in favor of the boycotting of the Vanderbilt contest. It being impossible to doubt the value of uniform rules for all great automobile races, and the European bodies as a whole being ill-informed on this matter, there is every possibility of the French boycott becoming a European boycott. The only way to prevent this would be for the American Automobile Association to put its side of the case before the conference. Europe needs educating.

## NEW YORK CLUB NAMES DATE FOR ITS EUROPEAN RACE

THE Automobile Club of America has announced Thanksgiving Day, November 26, 1908, as the date of the race it proposes to run at Savannah under European rules. Not more than three cars of any one make will be eligible to compete. Although there has been no limit set to the number of cars eligible to compete, the club's contest committee reserves the right to run eliminations, if necessary. As the club is understood to have guaranteed the Savannah club a minimum of at least twenty foreign entries, if its guarantee be made good, there is a chance that this condition may arise.

The entry fees are as follows: \$750 for one car; \$1,300 for two cars of the same make; \$1,750 for three cars of the same make—thus providing \$750 as the fee for the first car, \$550 as the fee for the second car, and \$450 as the fee for the third car when a maker enters a full team of three machines. A deposit of \$300 per car must accompany each entry when the blank is filed with the committee.

Entries will close October 1, at regular fees, but additional entries will be accepted up to November 1, upon payment of an extra fee of \$250 per car.

The limitations of weight and cylinder volume set forth in the club's official announcement follow, of course, strictly the European rules, which call for a bore of 6.1 inches (155 millimeters) maximum for four-cylinder cars, or the equivalent in an effective surface, or 75.4678 square millimeters for machines otherwise cylindered, and a minimum weight of 2,424 pounds (1,100 kilos) including oil for the motors and transmission.

Coincident with the announcement of the date and conditions of the race was an appended statement that the Acme Motor Car Company had wired for an entry blank and would enter a car in the race. H. S. Sternbergh, president of the company,

phoned a New York representative that his company had sent no such telegram and had reached no such decision.

"A great mistake has been made in this matter," said he. "No telegram of this character or anything which could be interpreted as signifying the intention of this company to enter, at this time, the Grand Prize race, has been sent by me to the Automobile Club of America. I have investigated the matter this morning and can find no official or employee of this company at the factory who has sent such a telegram. I have asked the Automobile Club to explain to whom the telegram was sent and how it was signed and when sent."

Subsequently it transpired that J. C. Finney, the company's Savannah agent, had bespoken a number in the race. Learning this, Mr. Sternbergh wired: "We learned this morning from our Mr. Finney, in Savannah, Ga., that he had entered one of his cars in some race or other to be held at Savannah. We do not know what race, nor when. Of course we, as the Acme Motor Car Company, have nothing to do with this entry."

Arthur W. Solomon, secretary of the Savannah Automobile Club, who has been in New York this week in consultation with the local club's officials and contest committee, made public the fact that on June 5 the club's resignation had been forwarded to President Hotchkiss and its receipt acknowledged. At the same time the resignations of Frank C. Battey from the Racing Board and Arthur W. Solomon from the Touring Board were also forwarded. These resignations were, of course, to be expected in view of the club's decision to cast its racing lot with the New York club. As the resignations had not yet been acted upon, Secretary Elliott, of the A. A. A., did not, of course, make public the fact that they had been handed in, but it is anticipated that this will be announced within a few days.

### A. A. TOUR WILL BE A TRIUMPHAL RUN.

Participants in the annual A. A. A. tour, which will embrace contests for the Glidden and Hower trophies, according to reports received at the Touring Board headquarters in Buffalo, are justified in anticipating the same triumphal passage as has always characterized their reception along the route of the run.

Chairman F. B. Hower reports that the number of entries to date is the same as at the same time last year, although the definite assurances from manufacturers indicate a larger entry than last July. Mr. Hower says he cannot understand why the participants do not take advantage of getting a low numeral by entering early instead of waiting till the last week as they usually do. Entries for the tour close July 3 with F. B. Hower, 760 Main street, Buffalo, N. Y. The entries to date are:

**For Glidden Trophy**—No. 1, Charles Clifton, Great Arrow; No. 2, Charles Clifton, Great Arrow; No. 3, J. W. Maguire, Great Arrow; No. 4, R. M. Owen, Reo; No. 5, E. H. Parkhurst, Peerless; No. 6, E. H. Parkhurst, Peerless; No. 7, E. H. Parkhurst, Peerless; No. 8, R. M. Owen, Premier; No. 9, R. M. Owen, Premier; No. 11, Gus G. Buse, Thomas.

**For Hower Trophy**—No. 100, R. D. Garden, Great Arrow; No. 101, R. M. Owen, Reo; No. 102, W. H. Vandervoort, Moline; No. 103, Charles Clifton, Great Arrow; No. 104, Henry Johnson, Premier.

**For Certificate**—No. 10, Paul Gaeth, Gaeth.

**Non-Contestants**—No. 18, R. M. Owen, Premier Pilot Car; No. 99, Charles Clifton, Great Arrow, Chairman's car.

### TO HAVE A BALLOON PARK AT WORCESTER.

WORCESTER, MASS., June 15.—J. P. Coughlin, president of the Worcester Automobile Club and a member of the New England Aero Club, announced last Saturday that Charles J. Glidden of Boston, the famous globe-encircling automobilist and vice-president of the Aero Club, was negotiating with him to at once establish in Worcester a park for balloon ascensions.

### REEVES LOOKING FOR CHICAGO SHOW PLACE.

CHICAGO, June 11.—Alfred Reeves, general manager of the American Motor Car Manufacturers Association, passed two days in Chicago this week canvassing the situation as regards the holding of an independent show in this city next winter. The A. M. C. M. A. had had some correspondence with the two local organizations, the Chicago Automobile Club and the Chicago Motor Club, relative to the two bodies assisting the dealers in the promotion of the affair and it was with the idea of looking over the available buildings that Mr. Reeves came to Chicago. While here he conferred with representatives of each club and also looked at the two buildings under consideration—the new Seventh regiment armory and the Dexter park pavilion at the stockyards. The former building, he thought, was too small for the purpose, while he changed his mind regarding the stockyards proposition when he found that the elevated express service could land people at the doors in 18 minutes from downtown. The pavilion has 20,000 square feet more than either the Madison Square Garden or Grand Central Palace, and Reeves greatly fancied it. However, no final action will be taken in the matter until the next meeting of the show committee of the A. M. C. M. A., which will be held late this month or early in July.

### SCRIBES AND SALESMEN TO CROSS BATS.

A feature of the annual reunion of Oldsmobilists, which is to be promoted on Saturday at the Columbia Oval Cricket Club grounds by General John T. Cutting, the head of the Olds Motor Works' New York agency, will be a baseball game between a nine made up of metropolitan automobile writers and a team of the agency's employees. Oldsmobile owners, candidates for the car to be drawn for by lot, will parade to the Oval, starting from Broadway and Fifty-first street at noon.

## MANY THINGS THAT THE CLUBS ARE DOING

### BAY STATE CLUB MOVES TO THE CARLTON.

BOSTON, June 16.—The Bay State Automobile Association is shortly to move into new quarters in the Carlton Hotel in upper Boylston street. On the first of next month the clubhouse which has been occupied for several years on Dartmouth street will be vacated and the club will move to the Carlton, where a commodious and handsomely furnished suite of rooms is being prepared. The clubhouse has proved rather larger than was needed and the expense of maintaining a restaurant has been excessive. At the hotel the club will have the benefit of the hotel's restaurant and service facilities and yet will be as exclusive as in a separate house. The suite of rooms is large enough to provide for all the comforts and conveniences that are now enjoyed, and the location is excellent, the hotel being situated very near the automobile trade district and at the very entrance to Boston's splendid park system.

### ACTIVITIES OF THE CHICAGO AUTO CLUB.

CHICAGO, June 15.—Autoists here have found it impossible to revive interest in the once popular social tour. This became evident last week when Chairman A. J. Banta of the runs and tours committee of the Chicago Automobile Club called off the run to the Hotel Moraine, Highland Park, scheduled for Saturday, June 6. Mr. Banta had high hopes at the beginning of the season that this would prove popular again this year and planned several attractions. However, notices sent to members regarding the Highland Park run went practically unheeded and as a result it was called off. One run will probably be held during this summer. This is the tour contemplated to Gary, Ind., the new town of the United States Steel Corporation. This run will probably prove a drawing card as it has as attractive features a visit to the steel plant and a road ability contest.

### NEW HAMPSHIRE AUTOISTS BEGIN WELL.

KEENE, N. H., June 15.—To signalize its recent successful organization, the Cheshire County Automobile Association held its first annual meeting and banquet in Wildey Hall, upwards of fifty members, beside guests, being in attendance. Dr. I. J. Prouty is the president of the newly-formed club; D. W. Goodnow, vice-president; F. J. Bennett, treasurer; F. A. Wright, secretary, while the directorate is composed of Dr. J. B. Hyland, J. A. Toof and D. W. Goodnow. The organization started off with a charter membership of 40, but its list is rapidly on the increase. Every autoist in the county must be enrolled.

### JERSEY CLUB FIGHTS NEW BRUNSWICK JUSTICE.

NEWARK, N. J., June 15.—Driven to desperation by the contemptible attitude of the authorities of the town of New Brunswick and of Justice of the Peace W. A. Housell in particular, the New Jersey Automobile and Motor Club has decided to undertake a campaign against both New Brunswick and its prejudiced "J. P." Two motorcycle scouts will be posted at each end of Housell's special trap to warn all comers of their danger, as it has been found that men on foot could not accomplish the purpose effectively. In addition to the man assigned to the trap, a third will be stationed at the justice's office to keep tab on the fines and to inform the victims that they can go before any other justice and be assured of fair play. The plan also includes the stationing of a man at the Tottenville ferry from Staten Island to urge all autoists crossing there to cross the bridge and pass through South Amboy to Old Bridge, the roads in that direction being fully as good as those via New Brunswick, as this diversion of traffic will rouse the interest of hotel keepers to what is going on. The club will endeavor to have another "J. P." sitting in the vicinity of Housell's office.

### TEN-MILE TRACK IN PROSPECT AT BRIDGEPORT.

BRIDGEPORT, CONN., June 15.—Headed by T. H. MacDonald and Bernard Setzer, a number of the leading members of the Automobile Club of Bridgeport have been inspecting the tract of land owned by the Lordship Park Association with a view to its purchase for the construction of a ten-mile circuit on which auto road races could be safely held. The interest in automobile racing here was evidenced by the fact that 10,000 people turned out to see the Sport hill-climb. The land in question is all marsh so that in building the road it could be easily flanked on either side by a moat which would constitute effective protection for the spectators, while the lay of the land is such that every mile of the course can be seen from a natural elevation on which a grandstand could be erected. It is estimated that the road could be built for \$50,000.

### GENEVA HOLDS ANNUAL "OFFICIAL'S RUN."

GENEVA, N. Y., June 15.—The Geneva Automobile Club has instituted a custom of holding an annual run on the occasion of which the heads of the local government, the police, a number of prominent citizens and the representatives of the press are invited to participate in a 50-mile drive as guests of the club, and this year's celebration of the event was held June 5.

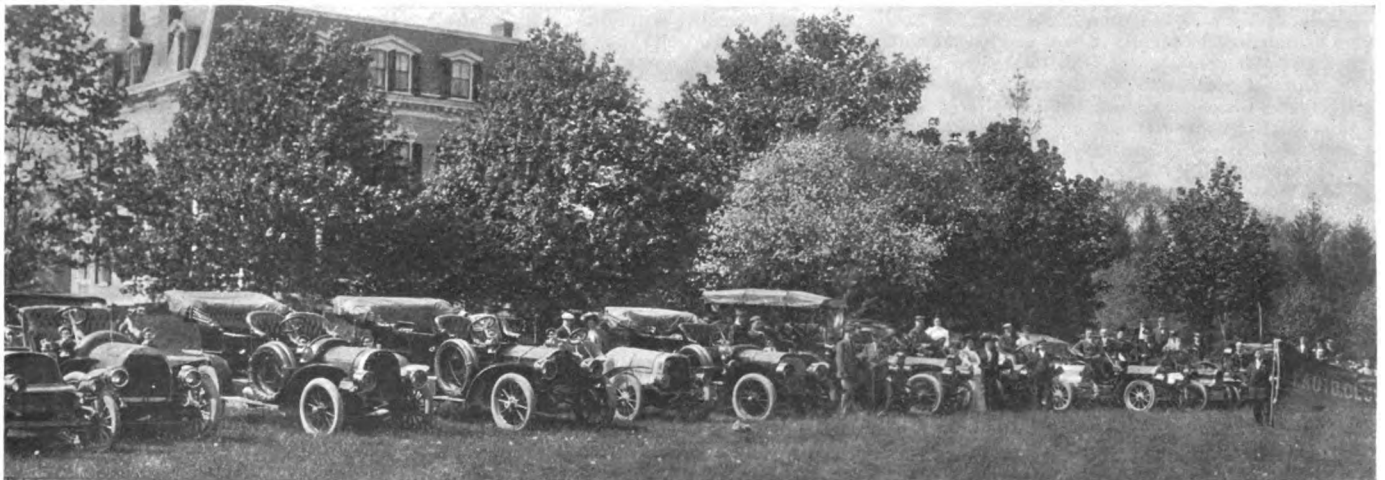

Scene at the Long Island Automobile Country Clubhouse, Bay Shore, L. I., on the Occasion of the Formal Opening.



There were 30 cars, carrying no less than 110 of the flower of Geneva's citizenship, and the run to Victor, N. Y., was made under ideal weather conditions. Though not a speed or endurance contest, a prize was offered to the driver of the car who adhered most closely to the schedule of one hour and twenty-five minutes for the distance. This was won by Dr. W. H. Jordan, whose car bore the unlucky number 13, the latter having been refused by a number of the contestants. The run was a most enjoyable affair and its holding is responsible for a most cordial feeling between autoists and the authorities during the remainder of the year, so that the custom is one that could well be followed elsewhere.

#### CONNECTICUT'S BODY GAINS RECRUITS.

HARTFORD, CONN., June 15.—W. F. Fuller, president, and G. K. Dustin, secretary, presided at a meeting of the Connecticut State Automobile Association, held at the Atlantic Hotel, Bridgeport, recently. Various standing committees for the season were named, and the newly-formed Rockville Automobile Club was formally admitted to membership. The association is adverse to speeding, and will do all in its power to discourage careless and reckless operation.

The New Britain motorists favor consolidation of their club with the Automobile Club of Hartford. The membership of the New Britain club is under 40, but there is plenty of funds in the treasury. It has not been definitely decided whether or not the smaller organization will be taken over by the larger. The former is not active. Mayor Landers, who is a member of the club, has just renewed his membership with the Hartford club.

#### ROCHESTER CLUB'S BUFFALO DELEGATES.

ROCHESTER, N. Y., June 15.—The delegates from the Rochester Automobile Club to the A. A. A. good roads convention at Buffalo in July will be President Henry G. Strong, Vice-president Wm. C. Barry, Jr., F. E. Mason, John W. Breyfogle, W. H. Campbell and Secretary Bert Van Tuyle. The club will hold a club run to Buffalo at that time which will be run in three sections, the first starting Monday, July 6, for an evening run; the second, Tuesday morning, and the last, Wednesday morning. It is expected that at least 150 cars will participate. The club's headquarters will be at the Lafayette Hotel.

#### NEW YORK CLUB'S TOUR STARTS FRIDAY.

The Automobile Club of America's pleasure tour of New England, which is planned to last nine days and embrace in its itinerary Poland Springs, Me., and Bretton Woods in the White Mountains, is scheduled to start on Friday of this week. The cars will be divided into three classes, each running on a separate time schedule as follows: Class 1, under 20 horsepower, 14 miles per hour; class 2, 20 to 40 horsepower, 18 miles; class 3, above 40 horsepower, 20 miles. Last Saturday it was announced that 15 cars had been entered, but the names of the entrants were withheld.

#### ROCHESTER CLUB'S SEVEN-DAY RUN POSTPONED.

ROCHESTER, N. Y., June 15.—Owing to the amount of business that is being done at present by the local dealers and manufacturers, it has been decided to postpone the holding of the seven-day endurance run planned by the Rochester Automobile Club, until later in the season, as it would be difficult for the business interests of automobile "row" in this city to spare a sufficient number of cars and men for an entire week just at this time.

#### SIoux CITIZENS ARE FORMING A CLUB.

SIoux CITY, IA., June 13.—An automobile club is in process of formation in this city. A club was in existence here three years ago but, owing to the small number of machines then owned in this city, it was not a success. Since then the number of cars has increased threefold.

#### BIG RUNS PLANNED TO WILDWOOD RACE MEET.

WILDWOOD, N. J., June 16.—The Motor Club of Wildwood is arranging for runs from New York and Philadelphia to its race meet on July 4. On Friday, the day before the races, the Quaker City delegation will start from Gloucester at 1 P.M. and the New York contingent from Jersey City at 7 A.M. It has been arranged for both runs to meet at Egg Harbor and continue together.

#### JERSEY'S BIG CLUB TO MOVE ON JULY 1.

NEWARK, N. J., June 16.—On July 1 the New Jersey Automobile and Motor Club will move from its former home on Broad and Chestnut streets to new quarters now being fitted up in the University Club Building, East Park street and Park place.

## MUTUAL FORBEARANCE BEARING EXCELLENT FRUIT

PHILADELPHIA, June 15.—Continuing its work of breaking down the mutual feeling of enmity existing between township authorities in Montgomery county and automobilists generally, the Automobile Club of Philadelphia in its latest bulletin says:

The club has received complaints from the Lower Gwynedd township authorities in regard to the manner in which automobiles are driven at the crossings of the Bethlehem, Sumneytown, and Penllyn pikes at Springhouse in Lower Gwynedd township. The feeling in the township is not against the speed at which the automobiles are driven on straight stretches of road with no crossings. The complaints are that drivers do not give half of the road to the teams and do not slacken speed at this crossing which is conceded to be dangerous. There are now no traps in this section. We ask the assistance and cooperation of every automobile driver in Philadelphia, and we request you to bring this to the attention of your chauffeur, if you do not drive yourself. If complaints of this character can be met by inducing motorists to comply with reasonable requirements with resort on the part of the authority to legal proceedings it will be very much to the advantage of all motorists in this part of the State.

The method of mutual forbearance, instead of the chip-on-the-shoulder attitude which formerly obtained is already bearing fruit in more reasonable regulations in the various boroughs and townships, and it is the policy of the club to hold on to everything in the way of a concession it can lay hands on.

Just at present the law committee has under consideration the

recent recrudescence of the "hold-up" habit in Cheltenham and Abington townships, which the Automobile Club of Philadelphia was instrumental in putting a stop to some years ago. It has been noticed that the stoppages of cars becomes more numerous with the opening of the season at Willow Grove. It is a well-known fact that upon the close of each night's concert, there is a rush for the city, and many impromptu races are pulled off. The club is and always has been opposed to the use of the roads for speeding purposes, and will do everything in its power to put a stop to the practice.

Chief Lever, of Abington, and Chief Lindsay, of Cheltenham, have both been doing a land office business, and within the past month the former's arrests have netted the township's treasury something like \$600 in fines. And this despite the comparative lenient treatment now in vogue. The authorities give automobilists a margin of five miles an hour on the 20-mile-an-hour stretches, and something more on the 10-miles-an-hour stretches; when they exceed the increased limit an arrest is in order.

Many of the drivers cannot be stopped, but their numbers are taken and they are communicated with and ordered to appear for a hearing. Some of them obey, and get off easy; others send the full amount of the fine; still others ignore the summons. The latter come up double or better when apprehended.

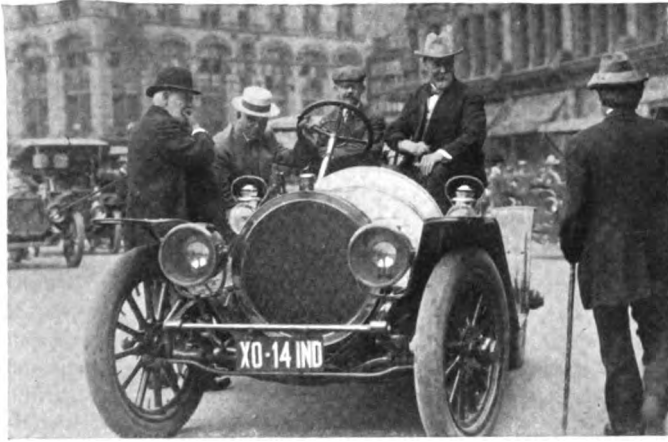

Vice-President Fairbanks Leads Indianapolis Parade.

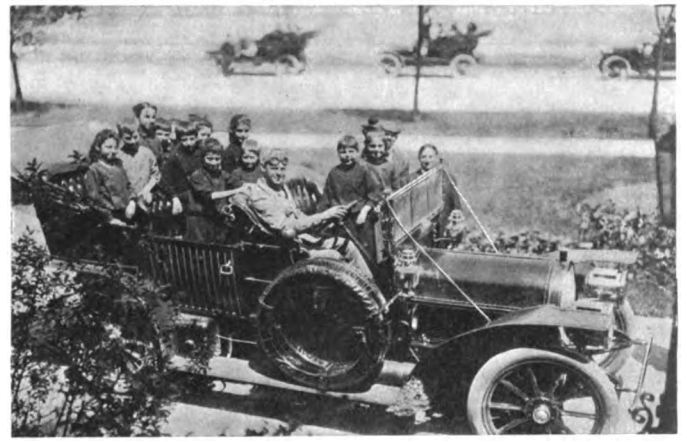

Parentless Little Ones of Chicago in a Tincher.

## HOW ORPHANS' DAY WAS CELEBRATED IN MANY CITIES

INDIANAPOLIS, IND., June 15.—Under the auspices of the Indianapolis Automobile Trade Association, 168 orphans of the city were given an automobile ride and outing last Wednesday afternoon. Among those who joined in the effort to make the youngsters happy were Vice-president Charles W. Fairbanks, Mayor Charles A. Bookwalter, Judge G. W. Stubbs of the Juvenile Court, Robert Metzger, chief of police, and several individual automobile owners.

There were almost fifty automobiles loaned by members of the association, manufacturers and private owners, that gathered at the foot of the Soldiers' and Sailors' Monument early in the afternoon. Each automobile was numbered and each youngster wore a tag bearing the number of the automobile.

Although an extremely busy man, Vice-president Fairbanks gladly consented to accompany the party as far as Thirty-eighth and Meridian streets, riding in a National roadster driven by Frank L. Moore of the Fisher Auto Company, and leading the long parade. Mayor Charles A. Bookwalter rode in a Premier as the guest of R. I. Eads of that company; Judge Stubbs of the Juvenile Court was the guest of P. D. Stubbs of the Overland Automobile Company, who drove an Overland, and Chief Metzger rode with Frank Staley of the H. T. Hearsey Vehicle Company in a White steamer. Four police officers rode in the car the Premier Motor Manufacturing Company is driving 100 miles a day for 100 days.

The children who were guests of the association came from the Indianapolis Orphans' Home, the German General Protestant Orphan Asylum and the Jewish Orphans' Home of this city and from the home of the Pentecost Band at Bridgeport, the children from that city coming to Indianapolis on a traction car.

the automobile association paying their fares. Following a ride of several miles, the youngsters were turned loose in White City, an amusement park north of the city, where all attractions were free to them.

### AGED TOO ON CHICAGO ORPHANS' DAY RUN.

CHICAGO, June 13.—The local celebration of orphans' day, which took place yesterday, with the three organizations, the Chicago Automobile Club, the Chicago Automobile Trade Association and the Chicago Motor Club, promoting the affair, was the greatest success this city has recorded in the three years it has been following the custom of giving the youngsters a free ride.

More than 175 cars were in line, and more than 1,300 participated. Departing from the usual custom, the promoters of the affair this time included the old people, an innovation which proved most popular, for it brought out many aged persons who never before had ridden in motor cars and some of them never had seen the full extent of the city's boulevard system. Sixteen institutions were represented and it is believed that no one was overlooked by the joint committee, at the head of which was Joseph F. Gunther, ex-president of the trade association.

It was believed by this committee that the children and young people would enjoy a long ride more than they would going to some amusement park for the afternoon, so this latter feature was cut out and instead a ride around the park system substituted. This in itself made a long jaunt, a 40-mile ride, and still not taking in all the roads under the supervision of the three park commissions.

Before the start each person was provided with an American

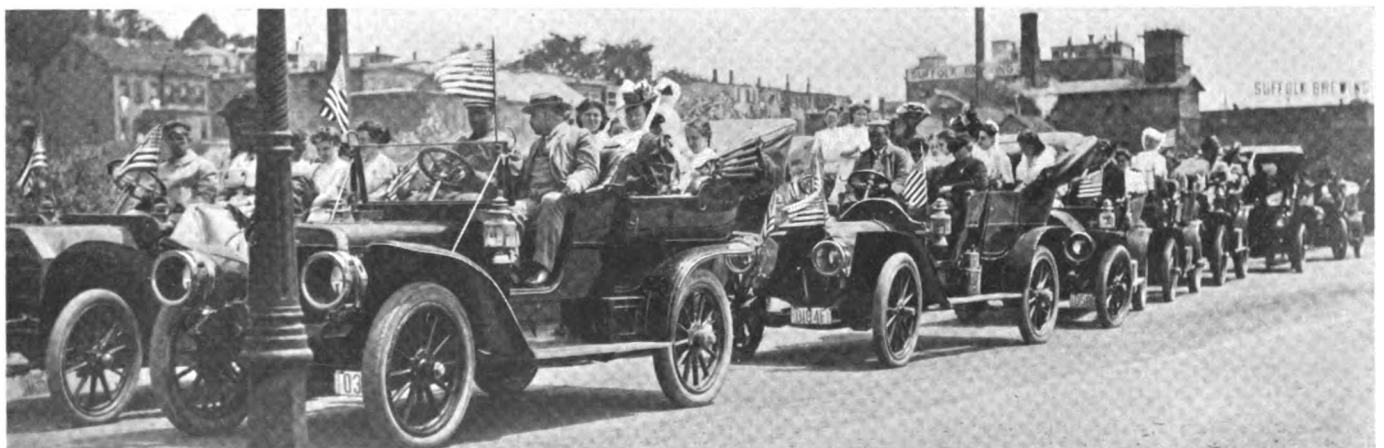

Blind Children Who Were Guests of the Boston Automobile Dealers' Association, on Way to Sharon.

flag and a bag of peanuts and candy and soon the smooth pavement was littered with peanut shucks, for the kids did not wait for the parade to start before tackling the bags. The 40-mile run took three hours.

#### BOSTON ORPHANS HAVE ANNUAL OUTING.

BOSTON, June 15.—The annual outing for blind children of Boston, given by the Boston Automobile Dealers' Association, took place last Thursday, and nearly one hundred and fifty little boys and girls, happy despite their affliction, were the guests of the local trade members in a trip to the town of Sharon, a beautiful country place about fifteen miles south of this city. In entertaining the little ones, about half of whom came from the Perkins Institution for the Blind in South Boston, and the other half from the Kindergarten for the Blind in Jamaica Plain, the dealers were assisted by Dr. M. R. Deming, superintendent of the Lake Shore home, a charitable institution located on Lake Massapoag in Sharon. The outing was in general charge of Chester I. Campbell, secretary of the dealers' association, and about thirty agents and managers supplied machines, several of them driving cars themselves so as to insure a safe journey for the youngsters.

The run to Sharon was made during the forenoon and, arriving at the Lake Shore home, the youngsters were let loose to enjoy themselves, teachers and the automobile men being on the watch to see that they did not harm themselves. At noon a substantial lunch was served at the home and afterwards there were boat rides, a concert and other amusements. The trip home was begun at about 4:30 o'clock.

#### HARTFORD CLUB OBSERVES ORPHANS' DAY.

HARTFORD, CONN., June 13.—The Orphans' Day run of the Automobile Club of Hartford, which was held this afternoon, was a complete success. About 200 children participated. They were carried in 45 cars donated by members of the club. The run was continued to Manchester Center, thence home by way of the north road, where a stop was made at Laurel Park, about six miles from Hartford. The cars were packed within the gates of the reservation and the little ones made for the park proper and the fun was soon at its height. Each child was provided with a substantial lunch. It was a sight to watch the youngsters get away with that lunch, and those who supposed that the parentless ones possessed no table manners were disappointed. As soon as one table was vacated another squad marched in good order and took possession. A stop of about an hour and a half was made at the park, during which time the youngsters took in all the sights of the park and let loose for a good time. When all the little ones had been fed and had had a good time start for home was made.

J. D. Anderson, president of the Hartford Rubber Works, drove his own Thomas Flyer and carried a large number of the little ones. C. D. Rice, another active club member, likewise a busy man, gave up his time to make the affair a success.

The committee in charge was Albert M. Kohn, chairman; C. D. Alton, Jr., W. C. Russell, A. G. Hinckley, C. H. Gillette and H. W. Nuckols.

#### QUAKER CITY ORPHANS VISIT WILLOW GROVE.

PHILADELPHIA, June 15.—A clear sky and the pleasantest of June weather but served to accentuate the paucity of vehicles last Wednesday, when the Quaker City Motor Club gave the orphans of the city their annual outing to Willow Grove park. Just seventy-two automobiles—touring cars, runabouts and motor trucks—showed up at the Hotel Walton and were assigned to various homes in as many sections of the city. By judicious squeezing and crowding about 900 little ones—boys and girls, black and white, crippled and whole—with their caretakers, were stowed away, more or less comfortably, and whirled away through the green lanes and country roads to that seventh heaven of

juvenile delight, Willow Grove, with its endless amusements. Arrived there, the guests were met by the committeemen and supplied with one or more—usually more—strips of admission tickets to the various attractions which add to the natural charms of the park. The committee which managed the affair consisted of Edwin H. Lewis, chairman; George W. Daley, secretary; George H. Smith, Charles J. Swain, Herbert E. Landell, Richard Sellers and Archie E. Hughes.

#### MONUMENTAL CITY'S OUTPOURING WAS BIG.

BALTIMORE, June 15.—Nearly 1,000 orphans were the guests of the Automobile Club of Maryland, last Wednesday, the occasion being the fourth annual outing for orphans. More than 200 cars, contributed by owners and dealers in this city, were in the line of parade which started from in front of the club's headquarters, Mount Royal avenue and Charles street. The cars were prettily decorated with flags, bunting and color schemes. When the bugle sounded for the start of the parade a loud cheer went up from the little ones, who were radiant with joy. An interesting route was arranged for the ride to Electric Park, where the guests were given supper, ice cream cones and cake. After this they were taken to the various amusements on the ground, including the Wild West and vaudeville shows. Four of the cars carried O. P. Steinwald's Band, which rendered music for the occasion. C. Howard Millikin and Dr. H. M. Rowe had charge of the arrangements.

#### MICHIGAN AUTOISTS REMEMBER THE ORPHANS.

GRAND RAPIDS, MICH., June 15.—Members of the Grand Rapids Automobile Club responded liberally to the call for cars to give the orphans their annual treat, and as a result several hundred of the little ones were entertained in a manner that they will long remember. The run was to Plainfield along the Grand river, a stop being made on the return drive at North Park, where lunch was served and the children amused by the various delights of the picnic ground. Automobiles have been kept busy entertaining for the whole week, a part of the official entertainment of the Merchants' Week visitors being a trip round the city in autos, while the Michigan Masons' convention was similarly treated.

#### PEORIA "GLIDE" CLUB HAS AN ORPHANS' DAY.

PEORIA, ILL., June 15.—This is the home of the manufacturers of the Glide cars, and owners of machines of this make have formed the Glide Club, which is a very flourishing automobile organization. The club observed the annual celebration of Orphans' Day by taking the children and their nurses from the Home of the Friendless for an outing, June 10.

#### THOMAS GAINS ON PROTOS IN SIBERIA.

After having been unheard of for fully a week or more, the round-the-world racers suddenly bobbed into view at Chita, the Protos' arrival there gaining the Germans the \$1,000 prize offered by the Siberian Railway. According to the *Times'* advices, the Thomas was only 20 miles east of Chita on June 16, having made up three of the five days' lead of the Protos caused by the breaking of a chain. The Zust is more than 1,000 miles behind and is said to be wrecked. Chita is 1,402 miles from Vladivostok.

#### CONTINENTAL TO HOLD READY-FLATED CONTEST

Prizes of \$10 for first and \$5 for second are held up by the Continental Caoutchouc Company, to chauffeurs or others, who can replace a punctured tire with a "ready-flated" Continental in the shortest time. The contest will be held at the Continental headquarters, Broadway and Fifty-eighth street, Friday, June 26. Three trials will be allowed, time being taken with stop watches. The prizes will be paid in gold.

**SHANKS LEAVES WINTON TO TAKE CHALMERS.**

CLEVELAND, O., June 15.—The resignation of Charles B. Shanks from the Winton Motor Carriage Company, and his announced intention of handling the Chalmers-New-Detroit in Cleveland and Northern Ohio has stirred the trade in this city as it has not been affected for many months. No one ever conceived the idea that Shanks and the Winton Company could be separated; had such an idea developed Shanks would surely have been offered sales managerships galore, for there is not a better known man in the trade.

"Just one reason prompted the change," said Mr. Shanks in talking over the shift yesterday. "Sooner or later every young man who considers himself in the 'live class' ought to get into business for himself, and in leaving my desk and taking on the agency for the Chalmers, I am merely following out an idea which I have been considering for a long time. I have only been waiting for the right proposition, and I am confident that I have found it."

In 1899 Shanks left the *Cleveland Plain Dealer* to become Winton advertising manager. In 1902 he was chosen to manage the Winton Company's new Cleveland branch, and the following year he was given complete charge of the company's large national selling organization, extending from coast to coast. His new salesrooms will be located on Euclid avenue in the heart of "auto row," and will be a very welcome addition. Mr. Shanks is very enthusiastic over his new work, and has made arrangements to cover northern Ohio very carefully. He will have at least three men working under him, and expects to do a large State as well as city business.

**E. V. PLANT MAY SUSPEND OPERATIONS.**

HARTFORD, CONN., June 15.—There is a general impression prevalent that July 1 will mark the closing of the manufacturing department of the Electric Vehicle Company's plant, only the repair end being maintained after that date. Should such prove to be the case, it will be a distinct disappointment to Hartford interests, as it has been hoped all along that the company would continue in some form. The failure of the Packard negotiations for the purchase of the plant was particularly regretted, and the present status of the defunct concern's affairs is a riddle that no one appears to be able to solve. Since the resumption of manufacturing a few weeks ago, close to 100 of the 28-horsepower Columbia cars have been marketed, and by substituting a sliding gear-set for the electric transmission, all the material purchased for the gasoline-electric car could be utilized. The receivers' report for May shows the cash receipts to the end of that month to be \$156,618.06, and the expenditures \$36,513.85, leaving a balance in hand of \$120,104.21.

**CHURCHILL BECOMES WINTON SALES MANAGER.**

Charles W. Churchill, who since 1906 has been manager of the New York branch of the Winton Motor Carriage Company, has been appointed general sales manager of that concern, with headquarters at Cleveland, to succeed Charles B. Shanks, who resigned that position a few days ago to engage in business for



Chas. W. Churchill.



Chas. W. Mears.

himself. Mr. Churchill has been associated with the Winton Company for a number of years and was assistant manager of the Cleveland branch before receiving the New York appointment, so that the change will be merely a return to the old territory so far as going to Cleveland is concerned.

**Mears Becomes the Winton Advertising Manager.**

Charles W. Mears, for four years past assistant manager to Mr. Shanks, has been appointed advertising manager for the Winton Company. Mr. Mears has had a number of years' experience in newspaper and publicity work, having been at one time the editor of the *Motor Vehicle Review*, now THE AUTOMOBILE. He showed his mettle as a publicity expert by winning the Arbuckle advertising contest which carried with it a prize of several thousand dollars.

**A MAXWELL-BRISCOE-BUICK COMBINATION.**

Negotiations for a consolidation of the Maxwell-Briscoe Motor Car Company and the Buick Motor Car Company are still in progress. It is said that the two other makers of small cars reported to have been invited to join the combination have decided to continue business independently, and at the present moment nothing definite concerning the progress of the negotiations for the consolidation of the plants of the two large makers of low-priced cars has been made public.



Licensed Engineers on Top of the Winton Plant at Cleveland on the Occasion of Their Recent Visit.

On the occasion of their recent meeting at Cleveland, the engineers of the Mechanical Branch of the Association of Licensed Automobile Engineers made a visit of inspection to the plant of the Winton Motor Carriage Company, and a group of them are shown on the roof of one of the buildings of the factory.





Pennsylvania Rubber Company's New Tire Ambulance.

### LATEST AUTO AMBULANCE IS FOR AUTOISTS.

BUFFALO, June 15.—There have been automobile ambulances of numerous different kinds brought out within the last year or two, but the autoist's interest in them has been purely academic. C. S. Pelton, manager of the Buffalo branch of the Pennsylvania Rubber Company, Jeannette, Pa., conceived the idea of a tire ambulance to play Good Samaritan to the many autoists who come to grief on Sundays and holidays and has executed it in the ingenious manner shown by the accompanying photograph. A light automobile delivery wagon has been secured and equipped with all sizes of Pennsylvania shoes, tubes and the like, as well as a complete supply of cement, patches and other necessities, while a Prest-O-Tire tank is carried to make the work of re-inflating the repaired tires easy. The car will run up and down the main traveled roads for a number of miles out of the city on Sundays and holidays and the aid thus offered will doubtless be found very welcome by many an autoist who would otherwise be stranded. During the first few days the experiment has been found to work even better than its originators had expected would be the case, so that doubtless the Pennsylvania ambulance will become a permanent fixture.

### DRINK TO PULLMAN'S NEW YORK SUCCESS.

An innovation in trade dinner giving was sprung at Reisenwebers' last Friday evening, when Cimiotti Bros., New York agents for the Pullman, invited their friends of the factory and the press to join with them in celebrating the sale of the last of the 1908 cars allotted to the metropolitan agency. It was a radical departure from the usual banquet, which often has as its real object the acceleration of the transfer of cars from the store to the customer.

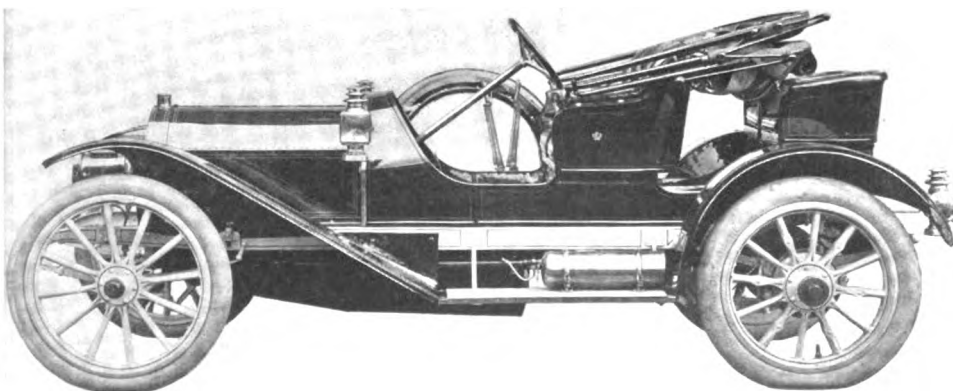

Neat and Attractive Lines of the New Moon Roadster.

Sales Manager O'Connor and Treasurer Stevenson came on from the Pullman plant to assist in the jollification and a dozen automobile press men were also among the celebrants.

Major Humphrey, on behalf of the Cimiotti "big three"—Ferdinand, W. C., and Paul—pictured in his choicest Shakespeare the triumph of the Pullman, and as toastmaster inspired the guests to lofty flights of post-prandial oratory. Among those to respond were: Ferdinand Cimiotti, J. P. O'Connor, Augustus Stevenson, W. H. Horner, L. C. Howell, C. G. Percival, W. W. Lee, E. A. Ward, H. F. Donaldson, Russell A. Field, E. E. Schwarzkopf, W. J. Morgan, Alex Schwalbach, F. W. McAllister and Louis R. Smith.

### PEERLESS BRINGS OUT A CLOSE-COUPLED BODY.

One of the latest additions to the Peerless line of special models is the close-coupled touring body shown by the accompanying photograph, this type of car being designed for the use of those who desire more accommodation than is afforded by the usual runabout type with its rumble seat, but do not wish to be burdened with the weight of the regular touring type of body. The

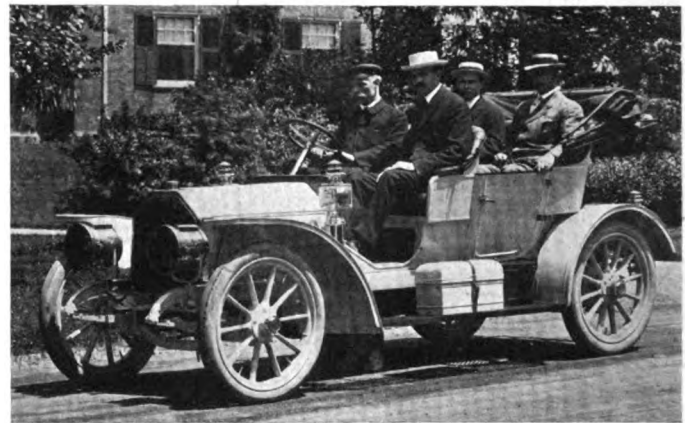

Engineer Schmidt at the Wheel of a New Peerless.

photograph shows Charles Schmidt, chief engineer of the Peerless company, at the wheel, Mr. Schmidt trying out the car after his recent return from abroad. E. H. Parkhurst, vice-president of the company, is seated beside Mr. Schmidt and H. E. Foote, the company's publicity manager, is in the tonneau.

### MOON BRINGS OUT A NEW ROADSTER TYPE.

Owing to the strong demand that has existed for what may best be termed a "handy car" last season, and which is more in evidence than ever this year, the makers of the Moon cars, the Moon Motor Car Company, St. Louis, Mo., have just added to their line the neat and business-like roadster type shown by the accompanying photograph. So far as looks go, the car is able to speak for itself better than any description, its lines and whole appearance being unusually trim and racy looking, while the double rumble seat in the rear gives it capacity for accommodating four passengers, and the two who are on the rear seats need not be as uncomfortable as is the usual lot of the "man behind" owing to the easy riding full elliptic springs with which the car is equipped. The use of a much smaller tire forward adds much to the neat appearance of the car and also facilitates steering, the equipment being 36 by 3 1-2 front and 4 1-2 rear.

## BRIEF ITEMS OF NEWS AND TRADE MISCELLANY

Another achievement was shared in by Pennsylvania Tires when O. F. Alcott, driving his six-cylinder Stearns with this tire equipment, won each of the three races for six cylinder cars, all in which he entered at the Jamaica Automobile meet.

The phenomenal growth of its business has necessitated the removal of the Penn Automobile Supply Company from the basement of 301 North Broad street, Philadelphia, to 236 North Broad street, where the entire building will be occupied.

In the report of Cedrino's death at Baltimore, it was stated that the accident was due to the right front tire giving way, but the wheels of the car when received by the Continental Caoutchouc Company showed that none of the tires had collapsed and all were still firmly attached to the rims.

The \$2,500 contest for Winton Six-Teen-Six chauffeurs will end June 30 and the prizes will be awarded as soon thereafter as complete reports can be submitted to the judges. Nearly all the contestants have made perfect scores—that is, have had no repair expenses whatever, so that the winners are likely to be those who have piled up the greatest mileage.

Although it was purely a stock car, the Simplex made a remarkable showing in the recent time trials at Jamaica, doing the kilometer in :32 and the mile in 51 seconds, while it covered the two miles in 1:44, these times coming particularly close to the star performer of the day, and leading the other competing four-cylinder stock cars by an ample margin.

An order, which seems to mark the beginning of an automobile experiment in the public transportation problem in Boston, was received by the Atlas Motor Car Company, Springfield, Mass., June 8, for 25 taxicabs, regular stock model, painted blue with yellow panels, from a new transportation company in the Hub, which also operates in Philadelphia. This is said to be the largest order of this type of car ever sent out from Boston.

The Speedwell Motor Car Company, Dayton, O., builders of the Speedwell car, have recently found it necessary to add a night shift to their working forces in order to be able to keep up with the constantly increasing flow of orders. Five new buildings have been added to the plant this season, but the business has already outgrown the capacity of the factory and further additions are contemplated in the near future.

Frank Yerger, in charge of the Studebaker Branch in Philadelphia, recently had occasion to make a few demonstrations of the Studebaker Model 22 electric runabout in Atlantic City, but instead of shipping the car by rail, decided to drive it over the road to Atlantic City, a distance of 66 miles. Although it rained most of the time, and the roads were bad, John White of the Philadelphia Branch, made the run easily on one charge of the battery and not a bit of trouble was encountered.

"We recently received from the Knox Automobile Company a set of eight bearings taken from one of their cars after a 15,000-mile service, with a request for a condition report," says the Hess-Bright Company, Philadelphia, Pa. "The most careful measurements showed that only one bearing had more than a half thousandth of an inch radial play. All bearings were in such excellent condition that they would

stand at least another 15,000 miles. This is by no means an unusual record for our bearings, as we have many instances of 60,000 miles run without trouble."

For the fire department of Greater New York the Diamond Rubber Company received in May an order for 14,000 pounds of solid rubber tires. To this order 12,000 pounds additional were added June 10, making a total of 26,000 pounds of rubber the Diamond company is to furnish for New York Fire department equipment for the coming year. The tires are of the internal wire and side wire type, and cover a great variety of sizes.

Added to the prestige of three new world's records made at the time trials at Jamaica, the Michelin Tire Company carried off the honors of the day among medium-priced cars also, a Pennsylvania car equipped with Michelin tires winning handily in its class; the owners of light cars vying with drivers of heavy cars in equipping with Michelin tires. Manager Hobbs of the New York Michelin branch reports a heavy percentage of purchases by owners weighing 2,000 pounds and less.

The National Sales Corporation has recently signed contracts with the Anderson Forge & Machine Company, Detroit, Mich., covering the sales of that company's product. By this arrangement the Anderson Company has secured the advantages of a complete selling organization, including office force and traveling salesmen familiar with the automobile accessory line, at far less expense than they could maintain an equivalent organization. The Anderson Company have a large plant particularly equipped for the manufacture of steam and drop hammer forgings in the rough or finished.

The Lozier factory at Plattsburg, N. Y., numbers among its large force several athletic organizations. The Lozier baseball team have this season proven the amateur champions of that section of the state. Last week, H. C. Pray, a member of the mechanical department, performed a feat of pedestrianism of more than ordinary ability, walking 52 miles from Lake Placid to Plattsburg through the Adirondacks in 9 hours and 55 minutes. Twelve miles of this walk was through deep sand. Harry Tyler, ex-world's champion bicycle rider, is now connected with the Lozier Company, having charge of the shipping department.

The Logan Construction Company, Chillicothe, O., has been shipping out a number of trucks recently, among them a Model S three-ton truck to the Fitzsimmons-Palmer Company of Duluth, Minn., a Model T one-ton truck to the Hoffman-Billings Company of Milwaukee, Wis.; a Model S three-ton truck to Proctor & Gamble, Ivorydale, near Cincinnati, O., prominent soap manufacturers; a Model S three-ton truck to Chris Mincy, Columbus, O., who will use it for passenger work, and a Model R delivery wagon to the John N. Loesser Mfg. Company of New York City. The Logan Company reports that the outlook for business is growing steadily better and that there is a good reason to believe that it will soon be better than ever.

"What's a record for if it's not something to be beaten at the first opportunity? One hundred cars a day wasn't even dreamed of three years ago. Last year we made it 83 in one day, last week we shipped 100 cars in one day, next week we may beat

it; next year we will *have* to beat it." That comment of Henry Ford is typical of the spirit of the man—the spirit which compels him to keep on pushing ahead to larger victories. He was commenting on the record-breaking day of June 4 when a total of 101 cars were built, tested and shipped in ten hours. This means a car every six minutes, ten cars an hour. The occasion was one of a series of attempts on the part of the manufacturing department to ship more cars than were sold in the same day. In this they almost succeeded—would have, had not several telegrams come in late in the day, bringing the total sales of the day up to 117 cars—another record, by the way.

"I don't believe the work done by Stearns cars the last two weeks in races, hill climbs, etc., all over the country, has ever been equaled by any other car before," said Roy F. York, vice-president of the F. B. Stearns Co., a few days ago. "It is all the more remarkable," continued York, "when it is remembered that all these reliability runs, hill climbs and speed contests have been won by amateur drivers and private owners. Some time ago we announced that we would not participate in contests as a company, and we have rigidly adhered to that policy. Many Stearns owners have entered such events, though, and in every case the Stearns has come through victorious. On Decoration Day and the following Saturday we took part in and won numberless events all over the United States, winning first place more than a score of times. It's all right to win as a company, as we have in the past, but when amateurs take their cars and do as good work as we could it means a great deal."

### PERSONAL TRADE MENTION.

W. J. Sprankle, who handles the Premier and Reo cars in Philadelphia, at 242 North Broad street, has secured the local agency for the Overland, and will at once begin enlarging his quarters to make room for the addition to his line.

Oscar Stegeman, for some time past chief engineer of the A. O. Smith Company, Milwaukee, Wis., manufacturers of automobile parts, has recently severed his connection with that concern. No announcement is made as to his immediate plans for the future.

J. Robert Maynes, who first came into prominence as a driver by winning the first 24-hour race in Philadelphia in an Autocar, has joined the selling force of the West-Stillman Company, the Quaker City agents for the Pennsylvania, Atlas, Pope-Waverley, and Mercedes.

Charles R. Greuter, who has been the designer and chief engineer for the Matheson Motor Car Company, Wilkes-Barre, Pa., since 1903, severed his connection with that concern on Monday last. He will spend some time in a New York hospital in order to have an injury to his leg, received in a recent accident, properly treated and will then announce his plans for the future.

Charles M. Strieby, long connected with the Ford interests in Philadelphia, and the organizer of the Ford Motor Club, in that city, was married on Saturday last in St. Francis de Sales' Church, to Mrs. Marie Lopez Pulsifer. After the ceremony the bride and groom left for an automobile honeymoon trip during which they will visit all the resorts along the Jersey coast.

**INFORMATION FOR AUTO USERS**

**The Recometre.**—"A perfect, permanent and positive record of every movement of the car, every minute of the day, every day in the year; records distance, speed, time, and stops, from start to finish." This, in the words of its makers, the Recometre Company of America, Broadway and Seventy-fourth street, New York, briefly

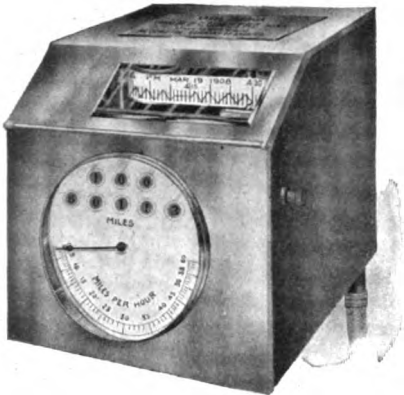

EXTERNAL VIEW OF THE RECOMETRE.

describes the purposes of this new instrument. It is a combination device consisting of a clock, a perfect calendar, showing the day, month and year, and it makes and shows a complete record, in ink, of the number of miles traveled, how many minutes it takes to make each mile and half mile, also the number of stops made, the time each stop was made, the number of minutes the car remained standing, and the exact time of starting the machine again. The record is mathematically correct, the recording pen being moved by gearing connected with the car, this record being made for every minute in the day and every day in the year. The speedometer attachment indicates speed and distance in the usual manner. The construction of the Recometre permits of the instant examination of the tape at any time of the day and has in plain view the record for the preceding half hour.

**U. S. Fireless Cooker.**—This is an improved method of cooking by means of retained heat that has been adapted for use on the automobile through the employment of a light and compact container made of the same material throughout—indurated fiber. This material is light, non-absorbent and hygienic, and will not rust, leak or crack, as is the case where metal is employed for the purpose. Several sizes of these fireless cookers are made, ranging from dinner pail up to the 8-quart size, and all have sufficient capacity for several dishes.



HANDY FOR AUTO RUNS AND TOURS.

the case where metal is employed for the purpose. Several sizes of these fireless cookers are made, ranging from dinner pail up to the 8-quart size, and all have sufficient capacity for several dishes.

**Sterling Timers for Fords.**—One of the latest specialties introduced by the Sterling Alternating Ignition Company, Binghamton, N. Y., is a vertical timer designed to be placed on Ford runabouts, Models N and R, to take the place of the equipment fur-

nished by the manufacturers. Its application is very simple, no tool work being necessary other than the drilling and tapping of two 1-4-inch holes in the cylinder to take the supporting bracket forming part of the outfit supplied. The gear is fastened to the camshaft by two small set screws, the gear case being held to the engine base with the same set screws that held the former bearing, which is replaced by the case. A dash bracket with bell crank is furnished, by means of which the timer is connected with the advance lever.

**PR Gasoline Indicator.**—This is one of the most practical and simple devices for indicating the depths of gasoline in a tank that has been placed on the market, the principle being that of a float rising on a spirally bent standard, thus causing the pointer to revolve about the dial. It is being manufactured and marketed by the PR Manufacturing Company, 621-659 Belle-

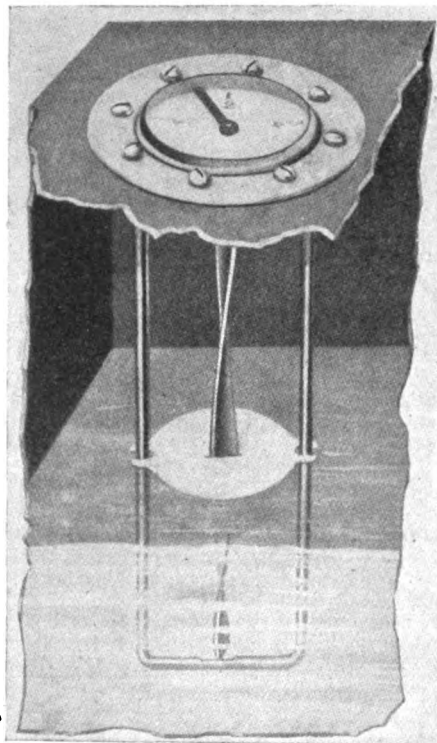

HOW THE PR GASOLINE INDICATOR WORKS

vue avenue, Detroit, Mich., and is constructed in such a simple and durable manner that it is practically indestructible. It can be attached to either a full or empty tank in less than ten minutes, no soldering being necessary. The dial face is protected by heavy plate glass, while the float is so constructed that it cannot stick at any point in its rise or fall, thus becoming dormant. The use of such a gauge not alone does away with the necessity of thrusting a dirty stick into the tank, but gives a certain indication of what mileage the car is making on its allowance of fuel, thus showing whether the motor and transmission are up to their original degree of efficiency, or not.

**G & K Tire Sleeve.**—This is a device which is the product of the Graton & Knight Manufacturing Company, Worcester, Mass., and is unique in being made from leather of a special grade from their own tannery. This leather combines extreme toughness with flexibility and long life. That part of the sleeve which takes

the greatest amount of wear is of double thickness and is heavily studded with iron rivets. It is designed to be laced to the

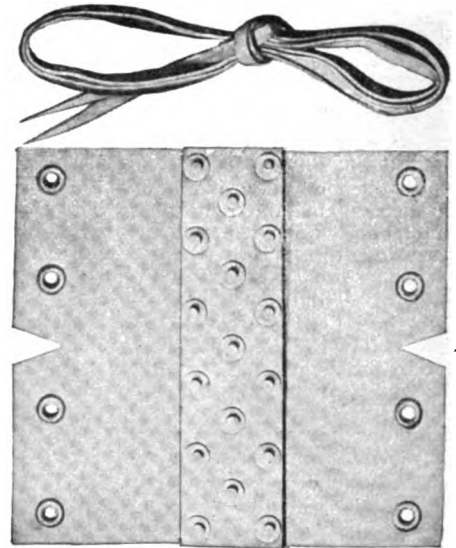

G & K TIRE SLEEVE AND LACING.

shoe of the tire, sufficient rawhide lacing being provided for this purpose.

**Trojan Hydro-Pneumatic Spring.**—Among the numerous advantages claimed for this new method of suspension for the automobile, the makers outline seven of the most important as follows: (1) There is no adjustment whatever necessary on this device as the piston is self-adjusting against wear and pressure and the whole spring is constructed so as to accommodate itself to any load. (2) You can dispense with pneumatic tires and use solid, thereby eliminating all tire troubles, and increase the safety of riding. (3) No more broken springs and coming home on slow speed with blockings between axle and body. (4) Ability to go at high speed over rough streets and roads without jolt or jar or danger to your car. (5) Simple construction makes your springs wear indefinitely and renders them indestructible. (6) Fulllest enjoyment and safety always. (7) Moderate prices for equipment.

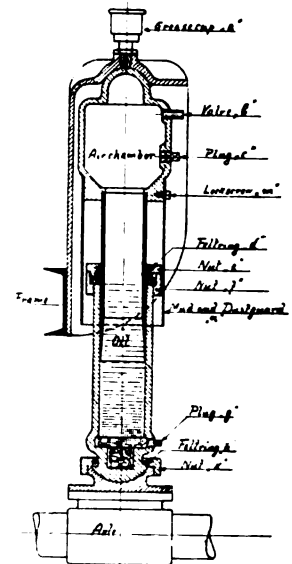

SECTIONAL VIEW OF HYDRO-PNEUMATIC SPRING.

As will be noted from the accompanying sectional view of the Hydro-Pneumatic spring, it consists of an air-chamber superimposed over a cylinder partially filled with oil. The former is attached to the frame of the car, and the latter to the axle and they are designed to move into one another in accordance with the variation in the load of the car and the shocks caused by meeting obstructions. It is manufactured by the Trojan Hydro-Pneumatic Wheel Company, Inc., Watervliet, N. Y.

# THE AUTOMOBILE

WEEKLY

NEW YORK—THURSDAY, JUNE 25, 1908—CHICAGO

10 CENTS



*The Tire you are coming to*



**T**HROUGH experiment and experience—to Goodrich Tires: that is the tire history of thousands of automobilists—but it need not be your history. You can eliminate the experiments and the expense by examining the Goodrich record of service; by learning the *road results* of the Goodrich “tough tread” and Goodrich “integral construction” on every street and highway in America. Start with a Goodrich equipment and you will finish with it. We shall be glad to explain Goodrich construction and furnish evidence of Goodrich superiority on request.

The B. F. Goodrich Company, Akron, Ohio.

CHICAGO  
PHILADELPHIA  
BOSTON  
DETROIT

CLEVELAND  
ST. LOUIS  
DENVER  
SAN FRANCISCO

LOS ANGELES  
SEATTLE  
LONDON  
PARIS

Our Products are also handled in  
NEW YORK and BUFFALO By  
THE B. F. GOODRICH COMPANY  
of New York.

Our Goodrich Solid Rubber Tires started in the lead fifteen years ago and have held their own ever since.



# American Locomotive Motor Car

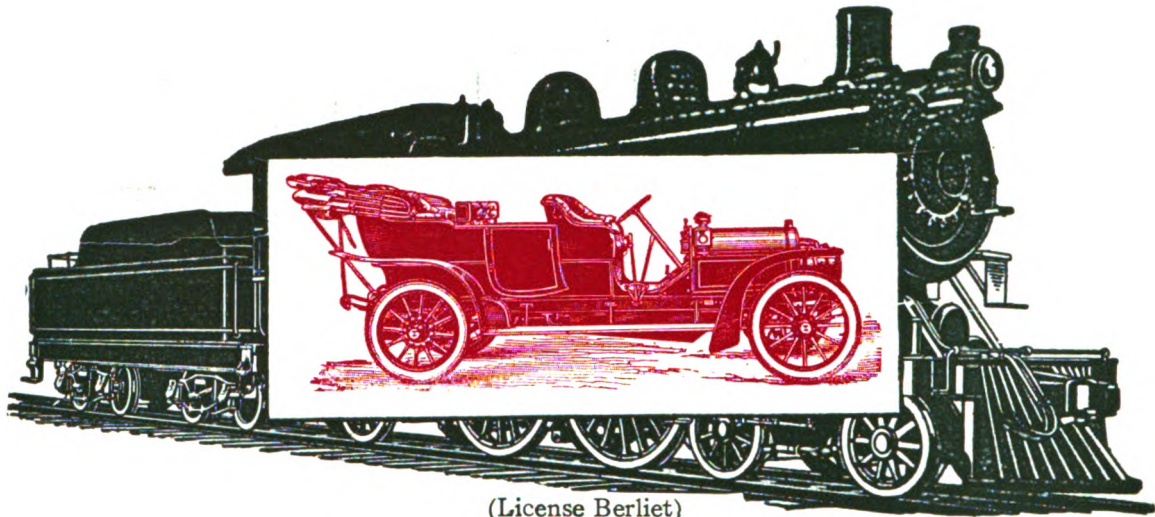

(License Berliet)

Imported Materials. American Workmanship.

An ideal worked out to practicality and success.

A composite of superiorities. Users say: "It Stays New"

## AMERICAN LOCOMOTIVE AUTOMOBILE COMPANY

FACTORY, PROVIDENCE, R. I.

1886 BROADWAY, NEW YORK CITY

"SPECIAL"



"OFFSET"



"ROUND"



The Justly  
CELEBRATED  
8-Day, High-Grade

## "CHELSEA" AUTO CLOCK

(Trade Mark)

Clocks built with a view to stand the jars and jolts and rough riding of Automobiles. Reputation the highest. Used by parties demanding the BEST.

ALL SIZES STATED ARE THE APPROXIMATE DIAMETERS OF THE DIALS.

All are 8-day High Grade. All are in DUPLIX (patent applied for) polished cast brass cases, the most thoroughly water-proof case on the market. The "SPECIAL" clocks show dial on an angle; its inner cased clock when removed from outer (locked) case is excellent for use on mantels, bureaus, etc., when touring; its outer case is screwed to dashboard by hidden screws. The "SPECIAL" clocks are in large demand from dealers for owners of finest cars.

The MOTOR CLOCK has the same clock movement which for years we have supplied for the hard use on Locomotives, Steam Fire Engines, etc.; its dial is of same appearance as the Auto Clock dial, but the Auto Clock movement has a somewhat finer train.

The 3 1/2" MOTOR "OFFSET" is likely to prove a quick, ready seller. Very attractive.

### PRICE LIST

SIZE	"ROUND"	"OFFSET"	"SPECIAL"	"LIMOUSINE"
2 1/2-inch Auto Clock	\$26.00	\$28.00	\$36.00	\$28.50
3 1/2-inch Auto Clock	28.00	30.00	45.00	Only made in 2 1/2-inch size in Limousine style
3 1/2-inch Motor Clock	24.00	26.00	41.00	

"Chelsea"

YOU want the BEST? CHELSEA CLOCK CO., 16 State St., BOSTON, U. S. A. Ask for the "CHELSEA"

Largest makers in America of exclusively 8-Day—High Grade Clocks: —Mantel, Marine, Office, Ship's Bell Clocks, Auto Clocks, etc.

"LIMOUSINE"



Primarily intended for use inside the bodies of large enclosed cars, and for such use its case can be given a variety of fine finishes. It also makes an attractive clock for use on dashboards. Only made in 2 1/2-inch size.

# THE AUTOMOBILE

## Prince Henry Tour Fittingly Succeeds Germany's Classical Herkomer



How the Start Was Made from the Suburbs of Berlin, Amid a Multitude of Onlookers.

FRANKFORT-ON-THE-MAIN, June 17.—Of 130 cars which started from Berlin on June 9 in competition for the Prince Henry Cup, 112 finished here to-day. The provisional winner is Fritz Erle, of Mannheim. The official list, however, has not yet been prepared, but will probably confirm the announcement.

The night stopping places which show the route of the tour were: Stettin, Kiel, Hamburg, Hanover, Koen, Trier and Frankfort. Most of the competing cars were of German make, but among the contending drivers were ten Belgians and nine Frenchmen, which gives the tour an international flavor.

BERLIN, June 9.—Teutonic method and thoroughness have reached their highest expression in the Prince Henry Cup, the great touring competition of the year, the substitute for the Herkomer Cup. To the uninitiated there was something strange in the 135 vehicles which presented themselves for weighing in at Charlottenburg, the charming suburb of Berlin, where Prince Henry presided in person and was assisted by a staff of military looking officials.

According to the regulations it is a touring competition of about 1,800 miles in seven stages, on a schedule fixed by the Emperor's brother and which must never be exceeded under any circumstances. It would perhaps be more correct to say that it is a procession, for the average speed for the different stages

remains around 30 miles an hour, on no account must the pilot car be passed, and it is not even allowed to go ahead of a competitor unless he is broken down.

Yet of the 130 competitors 100 at least are specially built cars with 4 1-2-inch bore engines having a stroke of 7 inches, specially lightened chassis, and four-seated bodies having as much resemblance to the real touring body as exists between the Stanley sprinter and a limousine. The reason for this anomaly is that the competition really resolves itself into a speed test and a hill-climbing competition. The touring procession will doubtless eliminate a few, for some drivers find it impossible to keep out of trouble, but practically all will be lined up for the straightaway test and the mountain speed work which will determine the awards. It is for these two tests that German manufacturers have built special long-stroke engines and designed four-seated aluminum bodies on the lines of a torpedo. It is for these two tests only that the cars are running with open exhaust, with horizontal mudguards, or without mudguards, with V-shaped front and with tumble home rear. There is a tremendous amount of publicity attaching to the competition organized by the Emperor's brother and the work of producing special models should bring its reward, when considered in the advertising sense.

For the final classification account is taken not only of the cylinder bore but of the weight of the car, the speed required



Special Body Built to Save Wind Resistance.



Another Special Type Not Designed for Comfort.

on the level and hills being in proportion to the bore of the cylinders. Before the start of each day's journey one hour is allowed for working on the cars, every extra minute being charged at the rate of 2-10 of a point. Stops on the road for any repairs other than those of tires will be penalized in the same way. Taking in of oil, for brakes or radiators, is penalized 5 to 10

points when this operation is performed away from the control.

The majority of the cars are of German origin, specially built for the competition. France, Italy and Belgium are represented by a few of the best factories of each of these countries, and England has a champion in S. F. Edge and one of his six-cylinder Napiers. In most cases the foreign cars are handled by amateurs.

## NAZZARO DRIVES 120 MILES PER HOUR AT BROOKLANDS

LONDON, June 17.—Nazzaro has beaten Edge at his own game, and at the same time put up a record for the Brooklands track of 120 miles an hour. It will be remembered that a few months ago, when S. F. Edge was under fire for his refusal to enter the Grand Prix unless detachable wire wheels could be used, a challenge was sent forth by the Napier manager to match his six-cylinder cars against any other car built for the great French race. The conditions were in favor of the Englishman, for he stipulated that the match should be run on the Brooklands track, and, as everybody knows, the Napier people have practically taken possession of the British autodrome.

The Fiat firm took up the challenge and sent over Nazzaro with a racer carrying a Grand Prix engine. On the start being given Newton, the crack track driver of the Napier company, shot over the line and got a good lead over the Italian four-cylinder car. On the second round the British six-cylinder was leading by 300 yards. Then Nazzaro opened out full, shooting ahead at such a speed that he rapidly overhauled the Napier and passed it amid tremendous excitement. As he went by the British car the official timers declared a speed equal to 111 miles an hour. A little further ahead the speed was still further increased by Nazzaro, the timers of the Royal Automobile Club swearing to 120 miles an hour. When two-thirds of the total distance of 27 1-2 miles had been covered, Newton, who was well to the rear, suddenly pulled up with a disabled machine. According to one report put forth by the employees an engine bearing had seized; another explanation was that a piston had broken.

Nazzaro, who is exceedingly popular in England, was handicapped by reason of his unfamiliarity with the Brooklands track and found it necessary to carry a mechanic with him. Newton, on the other hand, drove alone, his chances being further increased by the uninterrupted experience he has had on the Brooklands track since its opening. The defeat of the Napier is considered as a blow to British prestige, for Edge had earned for himself the reputation of being unbeatable at this class of speeding.

The sport was opened on Saturday afternoon, June 9, by an "All Comers' Handicap" of ten starters. An exciting struggle brought victory to a 35-horsepower Berliet, a 75-horsepower Mer-

cedes, and another 35-horsepower Berliet finishing close up behind the winner—an indication of the increased skill of the handicappers. Here it might be mentioned that, in connection with Brooklands, all engines are rated by the RAC formula of  $\frac{D^3H}{2.5}$ , without any reference to the makers' listed power.

A novelty was provided in the Limit Stakes, where any speed in excess of 50 miles an hour entailed disqualification, speedometers being barred, of course. The three cars which first passed the judge were all disqualified for passing the speed average, and Sir G. Abercrombie's Fiat was declared the winner, with 49 1-2 miles an hour to its credit.

The first of the three matches now attracted all the attention. Oscar Cupper's 26-horsepower Metallurgique was brought up alongside the 26-horsepower Napier, the distance being 14 miles and the stakes £500. Newton piloted the Napier, which was designated *Firefly*, in accordance with the new system of optional registration by name just adopted by the Brooklands authorities. From the start the Napier jumped away, and very soon it was apparent that the Metallurgique was out of the race, a faulty magneto proving its undoing. The average speed of the Napier was 78 1-2 miles an hour—an excellent performance for a four-cylinder engine of only four inches bore. The failure of the Belgian car was most disappointing, especially as this make is noted over here for its high efficiency and speed.

Monday, June 9, brought together the biggest crowd that has yet visited the course, the great attraction being the Napier-Fiat race for £500. Two heats of the handicap race for the Earl of Lonsdale's Cup were first run through, a 40-horsepower Vinot and a 36-horsepower Austin winning the two heats at speeds approaching 70 miles per hour.

The last event of interest was a novelty termed the Training Plate, confined to the three Austin racers which have been entered for the Grand Prix. After the first lap the cars had to be stopped, and the two rear types changed without any outside assistance, a second lap then being covered to the finish. Resta proved an easy winner, mainly owing to his extraordinary manipulation of the tires. Warwick Wright was second and Moore Brabazon, the amateur who won last Ardennes Circuit race, took third place.



## NO PRACTICE WORK ON GRAND PRIX COURSE

By W. F. BRADLEY.

PARIS, June 16.—There will be no trial spins on the Dieppe course before the Grand Prix, the Dieppe consultative committee and the Sporting Commission of the Automobile Club of France having decided that they are useless. Last year two days were allowed before the race in which drivers might become closely acquainted with the course. As fuel consumption does not now enter into consideration, it has been decided to abandon the tests, as they are not considered essential.

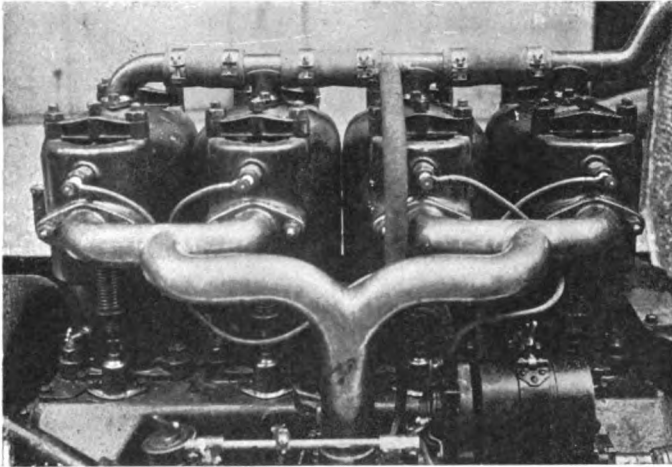

Power Plant of the Thomas Grand Prix Racer.

It would doubtless be more correct to say that the official trials have been abandoned for fear of accidents and in order that the road should not be spoiled. Out of over one hundred cars there is always a possibility of one meeting with an accident, and if anything of a serious nature should happen before the race a public outcry would certainly follow. When the work now in hand is completed the course will be in perfect condition, tarred from starting to finishing line, wider than it was last year—in brief, a sandpapered track. To let the racing cars loose would simply undo all the work of the past few months. The officials realize this, and have, therefore, taken the decision to keep the speed monsters off.

The American and the English teams are the only ones likely to suffer any inconvenience from the closing of the course. Strang has driven round on the touring car three or four times, and immediately on returning to Dieppe will recommence his daily practice work. Even if larger spockets are put on the touring car, however, the experience will be the same as a run round the course on the racer. Strang will thus have to learn what he can do on the sharp turns during the initial round on July 7.

Though the 47 miles of the Dieppe course will have a perfect surface on the day of the race, it must not be imagined that the task of the driver is limited to opening out his engine and letting his car run. From the grandstand on the Dieppe-Londinieres leg of the triangle there is a straightaway where 100 miles an hour is not at all an impossibility. A few turns of but little importance, then a descent is made into the village of Envermeu, which on the day of the race will be stoutly barricaded down

both sides and provided with a wooden bridge so that one side of the village street may not be altogether out of touch with the other.

From Envermeu to Londinieres is varied road; a few miles of straightway, with the primitive narrow track railroad as a companion on one side of the road, a few turns on down grades that will serve to keep the drivers awake, but nothing to cause any serious trouble. At Londinieres there is a double S turn passing over the railroad tracks—no trains will be running on the day of the race—followed by a long winding ride. This is undoubtedly one of the most difficult spots on the course, and the one on which the driver can best show his ability.

Immediately the double S turn has been negotiated, a winding climb commences and continues for three or four miles. Here again there will be an opportunity for a driver to show his skill, and to either gain or lose time, according to his ability. The hill-climbing power of the car will also be put to a test, for it will be necessary to drop into third speed for most of the distance.

Half way round the second leg there is a down grade that calls for a little caution, a short, stiff hill-climb, then a straightaway, on which Strang, who introduced us to the course, showed how his Thomas Flyer could run all out. Into the village of Eu there is a steep down grade. At the foot of the hill a wide hairpin turn has to be made through the center of the market place, then half a mile of 12 per cent. grade has to be negotiated. For five miles the road is a variation of up and down grades, calling for occasional touches of the brakes and a little handling of the change speed lever. When Criel has been passed through an opportunity is again presented to open out to the full along the seashore stretch of road. For ten miles it is possible to run all out, with but an occasional partial closing of the throttle for a few slight turns. During the last few miles of this shore stretch it is possible to look away to the left to the opposite side of the triangle on which the grandstands are placed. Three miles from Dieppe is the hairpin turn, necessarily calling for a closing down, but wide enough for the ordinary driver to get round without much difficulty. A mile further on, and the grandstands are reached.

Last year the club placed the stands a couple of miles from the Dieppe hairpin, on the seashore stretch of the road, but with their backs to the sea. This year they have been moved over to the opposite side, and are now on the outside of the course, with a northern aspect and open to the sea breezes. The change of position not only allows spectators to watch the cars on a long straightaway immediately in front of the stands, but per-

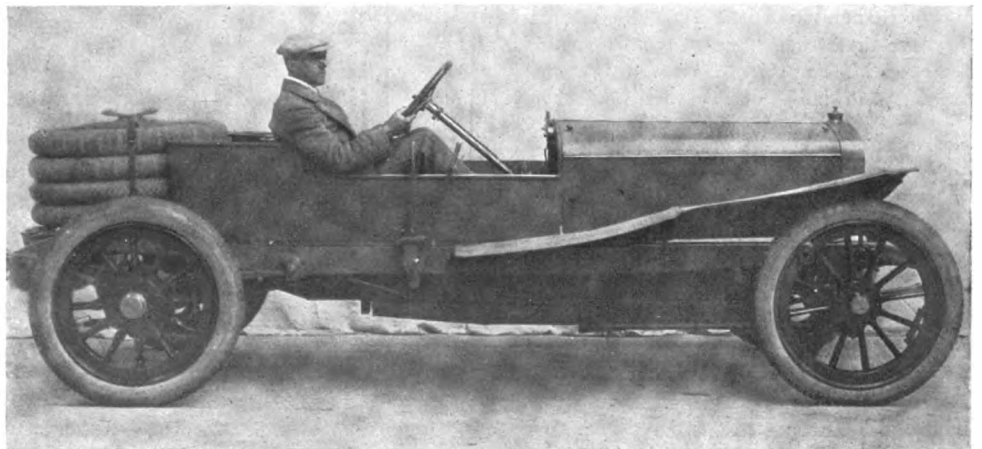

The Austin, the English Car That Drew First Starting Honors in Grand Prix.



mits them to look across country and see the cars speeding down to the hairpin. The turn itself is hidden by a dip in the land; the loss, however, will be of but short duration, and a second after the turn has been taken the car will again be in view on the inner straightaway.

Gasoline and tire stations are this year in a long pit at the foot of the grandstands. Spectators will thus have right below them the operations of changing tires, filling tanks, etc., immediately beyond some of the fastest speeding the course can produce, further away the outer leg of the triangle, and beyond that the blue waters of the English Channel. The score board will be on the inside of the course, built low, so as not to obstruct the view across country, and with figures, so say the officials, sufficiently large to be read without the use of glasses. A tunnel, already completed, will be the sole means of communication at this point between the outer and the inner side of the circuit.

America's car for the Grand Prix is now practically ready for the great test. Owing to damage in transit it was necessary to run up to Paris and fit a new radiator. Advantage, too, was taken of the dismounting of the engine for verification purposes to reduce the weight somewhat and make a few changes with a view to decreasing wind resistance. After carefully measuring each of the four cylinders and noting that there was a millimeter leeway, Comte de Lavalette, the club official, affixed the club seal and assembling was begun.

This week the entire Thomas team will leave for Dieppe, taking with them both the racer and the touring car. It is Strang's intention to make long runs out from Dieppe each day until the racer is in perfect condition, and to make himself thoroughly familiar with the course by an hour's practice with the touring car every morning. Harry S. Houpt and the members of the racing team are convinced that, although they may not be able to beat all the speed monsters of Europe, they will give a very satisfactory display of speed and endurance on July 7.

#### Sudden Death of Official Timer Tampier.

PARIS, June 16.—All who have been present at the great speed tests organized by the French club will read with regret of the sudden death of Charles Tampier, official timer of the Automobile Club of France. There is a certain amount of tragedy attached to the sudden removal of Tampier from our midst, for it was at first supposed that he had been poisoned at the club banquet in honor of the recent industrial vehicle trials.

Immediately after this banquet, offered at the clubhouse, and under the direction of the chef of the A. C. F., a number of persons were taken ill, some so seriously that medical attendance had to be called. Tampier was one of the number, the attack in his case being so grave that, after a few hours' suffering, he expired. A considerable stir was made in automobile circles, the report being freely circulated that Tampier had been poisoned as the result of partaking of canard a la rouennaise. A post-mortem examination has been held, the result of which has been to prove that the banquet was only partially responsible for the death of M. Tampier. So far as can be learned, the deceased had been in indifferent health for some time, and the slight poisoning set up at the banquet in his case proved fatal.

M. Tampier, who graduated into the automobile business from the cycle trade, first came to notice by success on the wheel. In Paris he had been connected for some years with various automobile journals, and for a number of years had been one of the official timers of the Automobile Club of France.

#### BLANKS ARE ISSUED FOR SAVANNAH RACE.

The Automobile Club of America has issued entry blanks for the race it proposes to run at Savannah, Ga., on Thanksgiving Day, under European rules. The blanks embody the particulars and conditions announced by the New York Club and published at the time. Additional information given is to the effect that the length of the race will be 400.95 miles, made up of 15 laps of 26.73 miles each.

#### THOMAS CAMP NEWS FROM HOUPT.

At last Harry S. Houpt seems to have found time to write his partners some particulars of what the Thomas Flyer outfit has been doing in the way of preparation as America's sole representative this year in the Grand Prix to maintain the reputation of this country's sport and industry in the great annual international struggle over the Dieppe course on July 7.

Hitherto Mr. Houpt has found time only to write brief letters, promising another with fuller particulars of the situation at the American camp later. That tardy letter was received at the Harry S. Houpt Company, the New York representative of the E. R. Thomas Motor Company, of Buffalo, on Saturday.

Mr. Houpt writes that training quarters have been secured at Dieppe and that everything is now in readiness for the great race.

Those members of the racing team not holding the French driving license were obliged to undergo an official test in the streets of Paris. "Monty" Roberts, who was one of the unlicensed members, had to undergo the test, much to his amusement. After a quarter of an hour in traffic, however, the Government inspector was convinced that the pilot of the New York-Paris race knew enough about an automobile to be licensed.

One of the most important formalities in connection with the race was the verification of the cylinder bore, which as is well known must not exceed 155 millimeters. The operation was simplified on the Thomas car from the fact that the bore had been

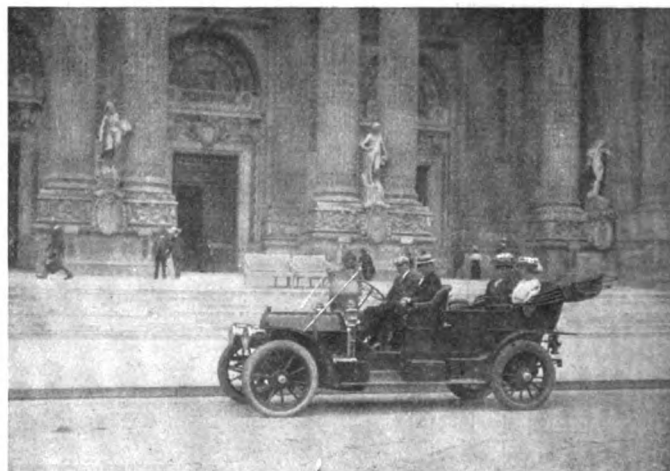

The Houpt Party in Front of Grand Palais, Paris.

In the Thomas Flyer are Mr. and Mrs. Harry Houpt and Miss McCartney. Montague Roberts is at the wheel.

limited to 154 millimeters, in order to prevent any possibility of dispute at the last moment. All European cars, on the other hand, have been built up to the full limit allowed under the rules. A few minor changes have been made on the car in order to reduce wind resistance and slightly decrease weight, but as it stands ready for the race the American champion is in every essential feature a stock runabout. All the European cars, on the other hand, are specially constructed cars, rating from 110 to 130-horsepower. By competing against Europe with an everyday product, it is believed that the best demonstration can be given of the reliability and endurance of the Thomas Flyer. Strang will carry with him as mechanic Auguste Guichard, while Montague Roberts, who has been entered as reserve driver, will be ready to take the wheel in case of any mishap prior to the race.

After a few days at Dieppe securing headquarters for the race, Strang drove the car down to Paris, covering the 100 odd miles in less time than is occupied by the express trains of the Western Railroad Company. This was accomplished on a Sunday afternoon, when, owing to the amount of traffic, it was necessary to proceed cautiously in all villages.

In common with all other firms, the Thomas Company will have a gasoline and tire stand immediately in front of the grandstand, and it is here that the mechanics and general utility men will be in readiness to hand over anything needed.



Where the Competent Corps of Track Officials Established Headquarters.

**B**OSTON, June 18.—The race meeting of the Bay State Automobile Association originally scheduled for Memorial Day was held yesterday at Readville track, and the delay proved more beneficial than otherwise. The track was in excellent condition and while no records were broken there were many fast miles, plenty of exciting brushes and the competition all through was close and interesting. The crowd of spectators was very large, it being estimated that seven or eight thousand people were on the grounds and six or seven hundred automobiles. Not a single accident of any kind to drivers, cars or spectators served to mar the afternoon's sport, and the prizes were well enough distributed so that nobody had a walkover. As not infrequently happens, the star attractions did not pan out as well as had been expected. Barney Oldfield and his Briarcliff Stearns had to take the dust in every event but a single heat of a five-mile race, and Christie's racer, driven by Morton Seymour, failed to work well in the match against Bowden's Flying Dutchman, driven by Charles Basle, though a little earlier in a one-mile exhibition the Christie made the fastest time of the day, circling the track in 56 3-5 seconds, only about three seconds slower than the record made by Baldwin with a steamer some years ago. Basle, driving an exhibition mile with the Flying Dutchman, could make no better than 58 seconds, though in the five-mile match against Seymour Basle's time was 4 minutes 49 2-5 seconds. In this event Seymour dropped out in the second mile.

The largest share of the honors went to the six-cylinder 45.6-horsepower Berliet, driven by H. F. Grant and entered by the Park Square Auto Station of Boston. Grant won the 20-mile stripped gasoline chassis event, after taking a preliminary five-mile heat,

and also won the five-mile handicap. In the 20-mile race Grant gave as pretty an exhibition of consistent driving and the Berliet of steady running as could be desired. Taking the lead at the start, the Berliet reeled off the 20 miles in 20 minutes 28 1-5 seconds, the miles not varying three seconds from start to finish. The second, eighth and ninth miles were made in one minute flat, and at the finish the Berliet had a quarter mile lead over its nearest opponent, the Allen-Kingston Briarcliff racer driven by Ralph DePalma, whose time was 20 minutes 44 seconds. In this event the Thomas "Blue Bird," driven by L. B. Lorimer, was going well until the eighteenth mile, when it had to stop because of tire trouble. The first preliminary five-mile heat was one of the most interesting contests of the day, for it brought together Barney Oldfield with the Stearns Briarcliff car and DePalma with the Allen-Kingston Briarcliff representa-

tive. Oldfield had to eat dirt from the start and was an eighth of a mile behind at the finish. DePalma's time was 5 minutes 13 seconds. The third car in the heat was the Corbin. In the second heat the Berliet had as opponents the Thomas "Blue Bird" and an American roadster driven by J. Andrews. The Berliet won in 5 minutes 19 1-5 seconds, the "Blue Bird" finishing in 5 minutes 26 seconds. The American did not finish.

In the five-mile handicap the handicaps were based on the fastest miles made by the different cars during the day, and the Berliet had 700 feet over the Allen-Kingston, which was on scratch, having made a mile in 58 2-5 seconds. The Thomas "Blue Bird," whose best mile was 58 3-5 seconds, was given 100 feet and the American had 3,600 feet. It was an easy victory for Grant and the Berliet in 4 minutes 59 1-5 seconds. The Allen-Kingston was second in 5 minutes 19 seconds.

There were eight events on the card and they were run off very smoothly with the exception of an interval when Seymour was endeavoring to get the Christie racer tuned up for the match with

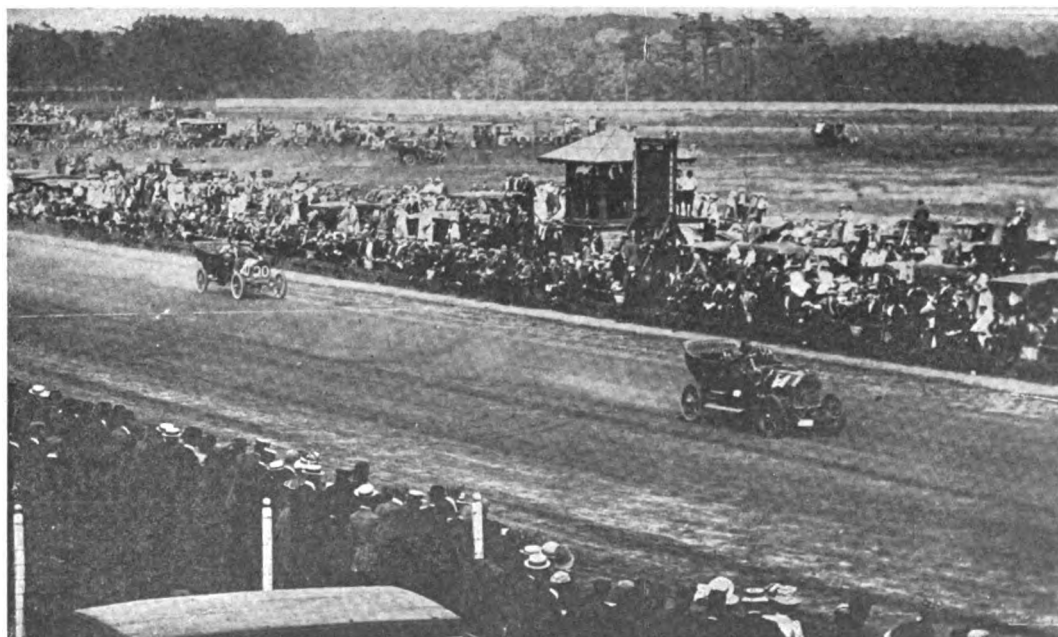

Webster in Stoddard-Dayton Overhauling Marmon in Five-mile Event for Touring Cars.

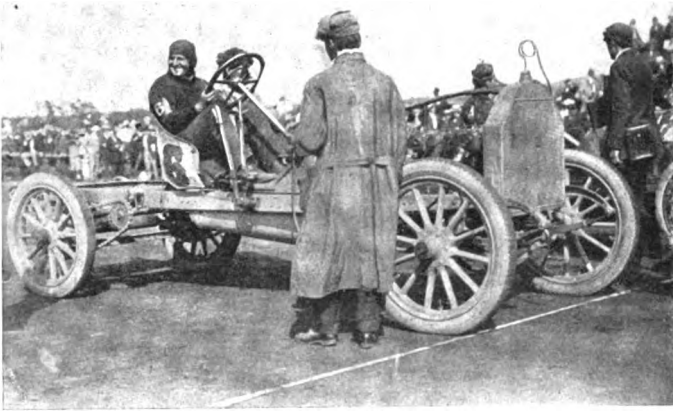

Grant and His Locomotive That Captured Two Firsts.

Basle. The racing began at 2 o'clock and the first event was at five miles for gasoline touring cars, 24.1 to 40 horsepower, with three starters, the 40-horsepower Marmon, entered and driven by F. E. Wing, the 40-horsepower Crawford, driven by the veteran manufacturer, R. S. Crawford, and the 36.1-horsepower Stoddard-Dayton, entered and driven by Stanley Webster. Wing cut out the pace for the first two miles, but it was too fast and he had to give place to the Stoddard-Dayton, which won in 6 minutes 10 3-5 seconds, with a half mile to the good over the Crawford.

The second event was the free-for-all gasoline stock runabouts and tourabouts, and it was run in two preliminary and a final heat, each of five miles. In the first heat were Oldfield with the Stearns and DePalma with the Allen-Kingston, and they made a pretty race of it. Barney got the jump at the start and cut out the five miles in 5 minutes 23 seconds, DePalma finishing in 5 minutes 44 seconds. In the second heat were the Thomas "Blue Bird," with Lorimer at the wheel, an American roadster driven by J. Andrews, and the Marmon driven by F. E. Wing. The Thomas had no trouble in winning by three-quarters of a mile over the Marmon, the American dropping out. The time of the Thomas was 5 minutes 31 3-5 seconds. In the final heat were the Stearns, the Allen-Kingston and the Thomas. After a false start the cars were called back and sent away a second time. De Palma won in 5 minutes 23 4-5 seconds, with the Stearns second in 5 minutes 29 1-5 seconds. The exhibition miles by Seymour with the Christie car and Basle with the Flying Dutchman followed. Then came the 20-mile stripped chassis race won by Berliet.

The 20-mile special race for gasoline cars of 40 horsepower or less, selling at \$3,000 or less, had five entries, but only two came to the tape, the Thomas "Blue Bird" and an Oldsmobile entered by the Algonquin Motor Car Company and driven by J. W. Snyder. Lorimer had things his own way, however, the Oldsmobile quitting in the seventeenth mile. The time of the Thomas was 21 minutes 56 2-5 seconds.

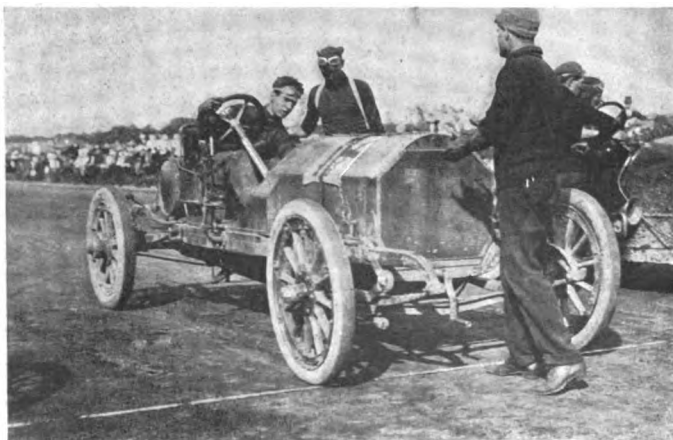

Thomas Detroit, with Lorimer, That Won Twenty-miles.

An amusing feature of the afternoon was the music. The band that was hired for Memorial Day played its program on that day safely protected from the rain on the clubhouse piazza. Fearing to undertake the expense of hiring another band for to-day, the management secured a Gabriel pipe organ, which was attached to a Peerless six-cylinder car and operated by W. W. Lusk, of New York. It proved an agreeable substitute. The summary:

**FIVE MILES, OPEN TO GASOLINE STOCK TOURING CARS OF 24.1 TO 40-H.P.**

- |                          |      |                      |          |
|--------------------------|------|----------------------|----------|
| 1. Stoddard-Dayton ..... | 36.1 | Stanley Webster..... | 6:10 3-5 |
| 2. Crawford .....        | 40   | R. S. Crawford.....  |          |
| 3. Marmon .....          | 40   | F. E. Wing.....      |          |

**FIVE MILE FREE-FOR-ALL, GASOLINE STOCK RUNABOUTS AND TOURABOUTS.**

**First Heat.**

- |                         |    |                      |      |
|-------------------------|----|----------------------|------|
| 1. Stearns .....        | 57 | Barney Oldfield..... | 5:23 |
| 2. Allen-Kingston ..... | 40 | Ralph DePalma.....   | 5:29 |

**Second Heat.**

- |                 |    |                    |          |
|-----------------|----|--------------------|----------|
| 1. Thomas ..... | 40 | L. B. Lorimer..... | 5:31 3-5 |
| 2. Marmon ..... | 40 | F. E. Wing.....    |          |

**Final Heat.**

- |                         |    |                      |          |
|-------------------------|----|----------------------|----------|
| 1. Allen-Kingston ..... | 40 | Ralph DePalma.....   | 5:23 4-5 |
| 2. Stearns .....        | 57 | Barney Oldfield..... | 5:29 1-5 |

**EXHIBITION MILE AGAINST TIME.**

- |                        |  |                     |         |
|------------------------|--|---------------------|---------|
| 1. Christie Racer..... |  | Morton Seymour..... | :56 3-5 |
|------------------------|--|---------------------|---------|

**EXHIBITION MILE AGAINST TIME.**

- |                                     |  |                    |     |
|-------------------------------------|--|--------------------|-----|
| 1. Mercedes "Flying Dutchman" ..... |  | Charles Basle..... | :58 |
|-------------------------------------|--|--------------------|-----|

**TWENTY-MILE STRIPPED GASOLINE STOCK CHASSIS. (Preliminary heats at five miles, final at twenty miles.)**

**First Heat.**

- |                         |    |                      |      |
|-------------------------|----|----------------------|------|
| 1. Allen-Kingston ..... | 40 | Ralph DePalma.....   | 5:13 |
| 2. Stearns .....        | 57 | Barney Oldfield..... |      |

**Second Heat.**

- |                  |      |                    |          |
|------------------|------|--------------------|----------|
| 1. Berliet ..... | 45.6 | H. F. Grant.....   | 5:19 1-5 |
| 2. Thomas .....  | 40   | L. B. Lorimer..... | 5:26     |

**Final Heat.**

- |                         |      |                    |           |
|-------------------------|------|--------------------|-----------|
| 1. Berliet .....        | 45.6 | H. F. Grant.....   | 20:28 1-5 |
| 2. Allen-Kingston ..... | 40   | Ralph DePalma..... | 20:44     |

**FIVE-MILE PURSUIT RACE.**

- |                                     |  |                     |          |
|-------------------------------------|--|---------------------|----------|
| 1. Mercedes "Flying Dutchman" ..... |  | Charles Basle.....  | 4:49 2-5 |
| 2. Christie Racer.....              |  | Morton Seymour..... |          |

**TWENTY MILES FOR CARS OF 40-H.P. OR LESS, SELLING AT \$3,000 OR LESS.**

- |                 |    |                    |           |
|-----------------|----|--------------------|-----------|
| 1. Thomas ..... | 40 | L. B. Lorimer..... | 21:56 2-5 |
|-----------------|----|--------------------|-----------|

**FIVE-MILE HANDICAP FREE-FOR-ALL, GASOLINE CARS.**

- |                                |      |                    |          |
|--------------------------------|------|--------------------|----------|
| 1. Berliet (700 feet).....     | 45.6 | H. F. Grant.....   | 4:59 1-5 |
| 2. Allen-Kingston (scratch) 40 |      | Ralph DePalma..... | 5:19     |

**JERSEY AUTO LAW CAUSES GREAT LOSS.**

TRENTON, N. J., June 19.—Men prominent in the State and automobiling were in attendance at the buffet smoker the Mercer County Automobile Club gave at the Dauphin Country Club last Tuesday evening. Among them were Judge William H. Speare, of Jersey City; F. H. Elliott, secretary of the A. A. A.; H. A. Bonnell, former secretary of the New Jersey Automobile and Motor Club, of Newark, and W. F. Sadler, Jr., former president of the Associated Automobile Clubs of New Jersey.

In view of the movement to organize autoists in every section of the State to cooperate with dealers and trade associations, the speakers dealt chiefly upon the advantages to be derived from organization. Mr. Bonnell stated that the members of the club at Newark would cooperate with the Mercer County in every way possible.

Statements were made to the effect that the tradesmen and merchants, hotel and garage proprietors had felt the effect financially and in other ways of the automobilists from other States not entering New Jersey, owing to the exorbitant fees which are required under the new automobile law.

**LOWELL'S FOURTH OF JULY RACE CALLED OFF.**

BOSTON, June 22.—It is definitely settled that there will be no 250-mile road race in Lowell on the Fourth of July. The Lowell club, however, has secured the passage of a law permitting the authorities of the city of Lowell and the adjoining town of Tyngsboro to close roads for an automobile race, and the club is now planning to hold the event on Labor Day.

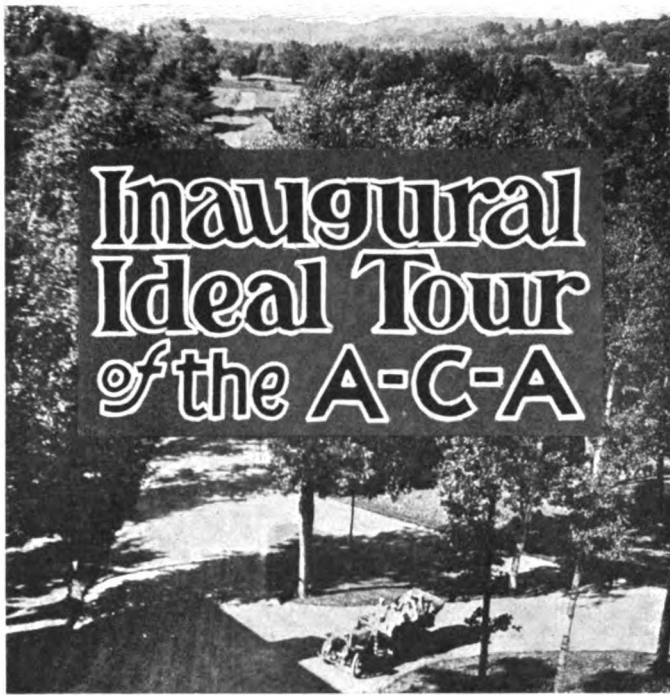

A HALF a hundred New Yorkers are touring New England this week in a caravan of a dozen cars. The occasion is the so-called "Ideal Tour," which is being promoted by the Automobile Club of America. It has for its object pure pleasure undiluted by point penalizations and without contest restrictions to hamper its go-as-you-please delights. To be sure, there is pretense of classification into three divisions of 20 horsepower, 20 to 40 horsepower, and over 40 horsepower, with speed limited respectively to 14, 18 and 20 miles per hour. All these restrictions, however, have been cast to the winds that the tourists may proceed untrammelled and happy on their way.

The "Ideal Tour" idea seemed good enough for 19 to make formal entries. Only 14 of them, however, showed up for the start from the palatial home of the New York club on Friday morning. The initial caravan was made up as follows: Pilot car, Stoddard-Dayton, Mr. and Mrs. A. L. Westgard; No. 30, C. G. V., Mr. and Mrs. Waldron Williams and Andrew Fletcher; No. 14, Simplex, Dave Hennen Morris and chauffeur; No. 5, Locomobile, Robert Lee Morrell and chauffeur; No. 4, Packard, Mr. and Mrs. Winslow Tracy Williams and chauffeur; No. 22, Peerless, Mr. and Mrs. Carl H. Page, Harry Urwin, H. F. Caldwell and Vance Schaerer; No. 10, Royal Tourist, Mr. and Mrs. Orrel A. Parker and chauffeur; No. 20, Darracq, Dr. and Mrs. Calvin T. Adams; No. 18, Fiat, Mr. and Mrs. Albert De Verastegin, daughter, Miss Helen, and chauffeur; No. 16, Peerless, Mr. and Mrs. Lamar Washington; No. 12, Lozier, Mr. and Mrs. R. F. Outcault, Mary Jane Outcault and R. F. Outcault, Jr.; No. 11, Lozier, Commo-

dore and Mrs. H. C. Roome; No. 19, Matheson, Mr. and Mrs. Daniel Daly; No. 21, Ford, Mr. and Mrs. F. D. Hughes.

Waterbury, Conn., 92 miles distant, was the objective point of the first day's run. The cars got away at average intervals of ten minutes. This and the comparatively small size of the touring caravan left nothing of a dust evil to be endured. The run was out the shore road to Norwalk, where the tourists rendezvoused for luncheon. At Stratford the caravan left the shore road for the picturesque highway along the Housatonic River. From Shelton the journey was through the beautiful Naugatuck Valley to Waterbury. The night's stop was made at the Hotel Elton, a new and well-appointed hostelry. An exciting incident of the first day's run was the rescue of two Yale students who had backed their car down a 30-foot embankment.

The roads met with were for the most part fine, though there were repairs in progress in the Naugatuck Valley. A new road, by the way, is promised between Shelton and Waterbury.

The better part of the second day's journey was through the Berkshire Hills. The objective point was Manchester, N. H., with Lenox the luncheon place. In the day's run of 137 miles the tourists drove through parts of three States—Connecticut, Massachusetts and New Hampshire. It was by no means an easy day's run, and many of the cars did not reach Manchester until 8 o'clock. A late start, however, was partly responsible.

Dave Hennen Morris and Robert Lee Morrell left the tour at this point, being called back to New York by business. Not all of the starters proceeded with the main party on Sunday's 74-mile run to Lake Sunapee, several deciding to lay over for a day or two. Many touring automobiles were met en route, however, and these joined the run for short stretches.

At Claremont a big delegation of autoists met the tourists and escorted them through the town. At Newport a reception was tendered by the town's Board of Trade. So hospitable were the Newporters that several of the cars remained over night and joined the tourists the next day at Soo-Nipi Lodge, for the ninety-mile run to Bretton Woods.

The run over the splendid New Hampshire roads in the White Mountains was an ideal one. It comes pretty near being the most picturesque automobile touring district in the United States. Comfortable inns and convenient garages are frequent. The ride through Franconia Notch over magnificent State roads was glorious. At the Profile House, mine host, C. H. Greenleaf, was on hand with a bowl of mountain-dew punch. At Bretton Woods the tourists were welcomed with characteristic warmth by their old Ormond friends, the Anderson and Price outfit, who had thrown open the Mount Pleasant Hotel abnormally early.

The tourists lay over at Bretton Woods on Tuesday and left for Poland Springs on Wednesday. They were met at Allen's Corners by a welcome delegation of the Portland Board of Trade and tendered a reception on their arrival at the Maine metropolis.

To-day's journey will be to Portsmouth, N. H., 81 miles; Friday's, to Boston, 68 miles; Saturday's, to Waterbury, 157 miles, and Sunday's, to New York, 101 miles.



At the Start in Front of the Big Clubhouse.



Rounding a Sharp Turn in Western Connecticut.





Where They Started at Broadway and Fifty-first Street.



Drawing the Lucky Number "129" from the Box.

## ANNUAL REUNION OF METROPOLITAN OLDSMOBILISTS

NEW YORK, June 22.—Oldsmobilists of the metropolitan district had their third annual reunion last Saturday. The Columbia Cricket Club oval at Williamsbridge was the scene of this year's outing. In the parade up Broadway, past "Automobile Row," over 200 Olds cars were in line. By actual count, 176 owners of Oldsmobile cars had been regularly entered, and were thus entitled to take part in the drawing for the choice of a \$3,000 palace touring car or a gentleman's runabout.

The founder of these reunions, which began in 1906, and have become a feature of the sport each year in the New York district, was Gen. John T. Cutting. The first two outings were held at the Empire City track and had racing for a feature, though, of course, the chief attraction has always been the prize drawing for an Oldsmobile, donated by the Olds Motor Works.

The preliminary parade started from the Olds agency, at Broadway and Fifty-first street, at half past eleven o'clock. It was headed by the Old Guard band in a big Packard truck. To the inspiring and oft-repeated strains of "My Merry Oldsmobile," the procession moved out Broadway amid the hearty cheers of "Automobile Row." In line were Olds cars of every type and vintage from the stately palace touring car to the curved dash runabout of days gone by. Of the latter there were close to two score. Some of them bore signs telling of mileage well up in the ten thousands. Some were gay with fresh paint. Others were dingy from wear and a bit slow in pace from overwork these long years. The procession made a brave showing, stretching for more than a mile along the Great White Way.

Arrived at the Oval, the cars lined up two deep along the running track. Lunch baskets were opened and on all sides was al fresco picnicing. Then came the ball game between a nine of

Oldsmobile employees and a team of automobile pressmen. All were in neat gray uniforms, just like real ball players, and it was a sight to see veterans of the "Senator" Morgan, "Jonah" Wetmore and "Pop" Ward vintage bravely cavorting around the diamond as youngsters of the Horner, McAllister, Hardy and Giegerich type. "Wag," as umpire, did his best for the scribes, but they lost 12 to 7, after five bone, muscle and nerve-racking innings, which left an aftermath of bruised shins and stiff joints over Sunday.

Then came the drawing. The lucky number was "129." L. L. Schmidt, a Hoboken hardware dealer, who had bought a 1908 Oldsmobile touring car in January, was its holder.

The occasion was one that will long be remembered by the customers of General Cutting, and his many friends, who were fortunate enough to be present.

### BRIEF DOINGS FROM THE TOWN OF TIRES.

AKRON, O., June 20.—The Diamond Rubber Company, of this city, is furnishing a large proportion of the tires for the Fire Department of New York City. At present the local company is filling orders for 26,000 pounds of tires for the metropolis, which represents all but 4,000 pounds of the annual requirements. The first order was received by the Akron company some time ago for 14,000 pounds, and a second order for 14,000 pounds was received June 10.

J. R. Bailey is representing the Diamond Rubber Company, and M. S. Johnson the B. F. Goodrich Company at the annual convention of the Master Car Builders' Association at Atlantic City this week.



The Contending Ball Teams and Multitudinous Array of Oldsmobiles Were Lined Up in the Background.

# AUTOGENOUS WELDING IN AUTO CONSTRUCTION\*

By E. S. FOLJAMBE, MEMBER SOCIETY OF AUTOMOBILE ENGINEERS.

IN dealing with the possible application of autogenous welding to the construction and repairing of automobiles I fully appreciate that the subject is so comparatively new that its practical field of usefulness has not yet been clearly and definitely defined. It would seem from the applications of the process and the extensive experiments which have been carried on abroad and are now being conducted by a few in this country that autogenous welding supplies the workers of metal a means of accomplishing many results which have heretofore been either impossible or only achievable by costly and difficult methods.

This process consists of welding, or, more correctly speaking, melting together metals by means of the oxy-acetylene flame, the temperature of which almost rivals that of the electric arc, being 6,300 deg. Fahrenheit. The facility with which it can be handled as compared with most other methods makes its com-

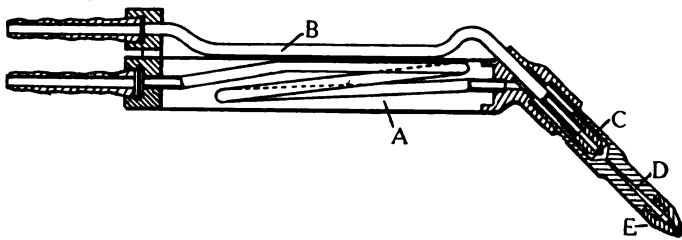

Fig. 1.—Section of Fouché Welding Burner.

mercial application comparatively simple. The possibilities attendant upon the use of a flame of such high temperature can be realized when it is remembered that the melting point of steel is about 2,570 deg. and that of platinum, one of the most refractory metals, is only 3,227 deg. F. Its chief field of usefulness is in combining such metal parts as would ordinarily be riveted, in welding small parts together, in repairing broken or defective castings and for cutting metals.

### Concerning the Work of Fouché.

Unquestionably the combination of acetylene and oxygen was first suggested by the familiar oxy-hydrogen blow pipe, but it was only after exhaustive experiments on the part of the noted French chemist Fouché that, in 1901, he was enabled to produce a successful burner using this highly explosive combination. He was led to use these two particular gases by his calculations which showed the extremely high temperature that would be generated by their union. In 1902 he patented his first cutting and welding burners. In 1905 he took out additional patents, and Fig. 1 shows a section of this later welding burner, the principle of which has not up to the present time been appreciably altered or improved. Since his introduction of a successful burner the development of the oxy-acetylene process has been principally in connection with the best and most inexpensive methods of producing these two gases.

### Details of the Burner Employed.

The most economical method of producing oxygen in commercial quantities is by means of distillation of liquid air, the cost having been reduced to something less than a cent per cubic foot. However, the familiar laboratory method of heating Black Oxide of Manganese (MnO) and Potassium Chlorate (K<sub>2</sub> ClO<sub>3</sub>) is largely used in this country, on account of the relatively low cost of the plant, although oxygen produced in this manner can hardly be sold for less than two cents per cubic foot.

The principal difficulty in designing a burner is to prevent the

flashing back of the flame at the nozzle, which might cause an explosion. Even several wire screens have been proved ineffectual preventives, as the intense heat of the flame instantly raises the fine wires of the screen to a red heat. The method employed by Fouché consisted either in using a small bore tube of great length coiled into the cylindrical part of the burner, A, Fig. 1, or of packing this space with mineral wool or asbestos, through which the gas could freely pass, but which successfully prevented the firing back of the mixture. As the tube is not of capillary size, it causes less resistance to the flow of the gas than the asbestos, and is therefore preferable. In a welding burner oxygen under about ten pounds pressure per square inch is admitted through the small tube B, and after passing out of a fine tipped nozzle, C, mixes in the injector-like chamber, D, and carries along with it the acetylene which has passed through the coil in cylinder, A. The mingled gases burn, but beyond the tip, E, due to the pressure, so the tip itself is not subjected to a high temperature, and can be made of brass or even copper. In the welding flame the acetylene is only under a pressure of three-quarters to two pounds per square inch, and the oxygen, ten pounds. For cutting, the same combination flame is used, but in addition a third tube for pure high pressure oxygen is provided, and so located that the oxygen strikes the heated metal just to the rear of the combination flame. The oxygen for the cutting burner is under about 150 pounds per square inch, and the acetylene 10 pounds.

### How the Burner Is Operated.

In operating the burner the acetylene is first ignited and the flame regulated by means of a valve at the end, so that it does not leave the tip. The oxygen is then turned on, the pressure being maintained constant by means of a reducing valve on the tank. The acetylene is then regulated until just sufficient to produce complete combustion, giving practically a non-luminous flame in the middle of which, however, near the tip, a slightly luminous cone, is seen, the point of which is the hottest part of the flame, and the burner is usually held in such a position that the tip of this cone touches the work. If an excess of oxygen is present the metal will very soon scintillate, showing that it is being burned. This, of course, has reference to the welding flame alone, as the cutting action is entirely due to an excess

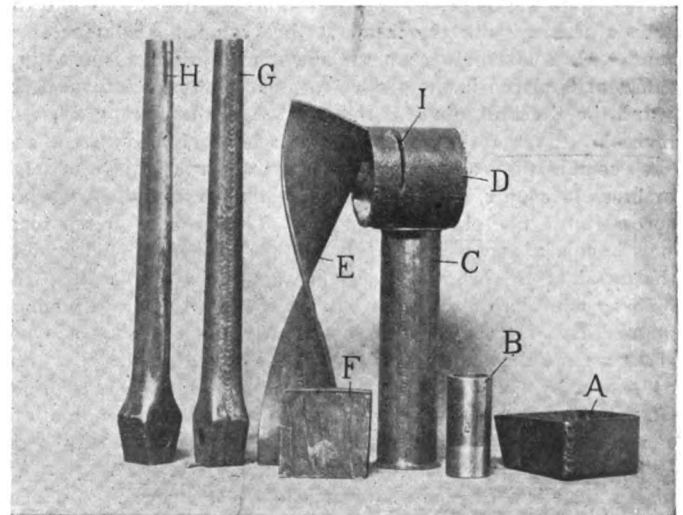

Fig. 2.—A, pressed steel forming a cup, showing rough-welded and finished edges. B, steel, copper and brass tubing welded together. C, thin copper tube made from a sheet. D, cast iron pipe cut off at ends by the flame, the width of the cut, which is about 1-8 inch, being shown at I. E, two strips of 1-8-inch sheet steel welded and twisted. F, section cut in 17 seconds from the end of a 2-inch bar of high carbon steel. G, spoke made of two pressed steel halves welded together. H, finished spoke.

\*Paper read before the Society of Automobile Engineers at Detroit, June 25, on the occasion of the third annual summer meeting of the society. The reading of the paper was accompanied by an actual demonstration of the various processes described, the apparatus for the purpose being supplied by the American Ferroflux Brazing Company, Philadelphia, Pa., to whom the author is also indebted for some of the data.

of oxygen, which causes the metal to burn at a very rapid rate. The extreme localizing of the heat makes it possible to use the flame in close proximity to soldered or brazed work without causing a separation of the parts thus united. On certain classes of work where it is desired to make an ordinary brazed joint the flame can also be used to advantage in heating the parts and melting the spelter.

#### Method Employed for Cutting.

When cutting, the combination flame is first turned on and used to bring the edge of the piece of metal to be cut to a bright red heat. Then the pure oxygen stream is turned on and the highly heated metal instantly combines with the oxygen, forming  $Fe_3O_4$  in the case of iron, and a path is almost instantly melted out as the flame is moved across the piece. The amount of metal burned away depends upon the width of the zone heated by the fore flame and the volume and pressure of the oxygen. The complete localizing of the heat is a peculiar and surprising feature, for although the metal for about an eighth or three-sixteenths of an inch is actually running out of the cut like water, the adjacent metal is not heated to a dull red for more than half an inch on each side of the cut. For cutting thin metals, oxygen under such high pressure is not as essential as when the work is thicker, and it has been found that after the melting process caused by the pure oxygen stream has started, it is almost unnecessary to have the combination flame carried ahead of the stream of oxygen, as the heat is so intense that the action after once started can be continued. This has been shown by using simply the flame from a welding burner to heat the edge of the piece to the melting point and then suddenly turning off the acetylene, allowing the oxygen jet alone to impinge upon the heated metal. This is rather difficult, however, for if at any time the metal cools even slightly below the welding point, the oxygen acts as a draft to cool it, and the melting ceases.

#### Its Application to Welding.

In uniting the edges of a sheet rolled to form a cylinder, or wherever the pieces do not lap, the edges are beveled so that when brought together a V-shaped groove is formed, the width at the top of the groove being about the same as the thickness of the metal. This rule applies to metals up to half an inch in thickness. The flame is directed into this groove, first melting the thin bottom edges; at the same time a piece of wire of the same material as that of the parts to be joined is held in the edge of the flame and thus kept at a bright red heat until the metal of the parts begins to flow, when the wire is immediately plunged into the flame, and being instantly melted, drops into the groove, uniting with the metal at the bottom. This process is continued, thus building up the metal until slightly more than sufficient is placed in the groove to fill it, so the piece can afterwards be dressed to make the surface of the joint flush and invisible. Even dissimilar metals can be perfectly united, and such combinations as copper, brass, cast or wrought iron to steel, or brass to copper, are possible. Aluminum can also be worked successfully. See photograph, Fig 2. The parts so united form one homogeneous piece, but with this distinction that, while the metal of the original sheets has a grain due to rolling, the built-up material of the joint has a structure similar to puddled metal. This is probably one reason why test specimens do not show a tensile strength equal to that of the original. However, as shown by the following report of the South Chester Tube Company on wrought iron pipe material welded by the American Ferrofix Brazing Company, the relative strength is very high, being about 95 per cent. of the original piece, which is much higher than can be obtained by riveting. It is even possible to increase this to 100 per cent. by simply heaping up the metal at the joint until the cross sectional area is somewhat larger than that of the original, but the elongation is noticeably decreased. However, the results shown by the appended table demonstrate in a striking manner what is to be expected of the new process. The following is the report of the experiment:

#### REPORT OF SOUTH CHESTER TUBE CO.

No.	Original bar.....	Ultimate Strength	Elongation	Elastic Limit
No. 1.	Original bar.....	49,580 lbs. sq. in.	11%	.....
No. 2.	Welded bar.....	43,040 " " "	5%	38,700
No. 3.	Welded bar.....	46,600 " " "	8.5%	35,800

#### Operations to Which It Is Adapted.

Although the cutting-off flame is of especial interest, its applications to automobile construction are much more limited than are those of the welding flame. In Paris, the flame has been used successfully on work as large as six inches in thickness, but so far as I am aware no cutting has been done in this country on work over 2 1-2 to 3 inches thick. However, the burners are daily being perfected and it is probably but a question of a short time when plates of a considerable thickness can be successfully cut. Although the intense heat of the flame has a slightly injurious effect on the alloyed steels, particularly if applied to sheet metal or comparatively thin work, still it is possible to rapidly cut out gear blanks, without injuring the metal to any considerable depth. It seems perfectly feasible to assume that when it is desired to form crankshafts from a slab or billet, it is possible to do this with the cutting flame in a very small fraction of the time now consumed by those few makers who employ the slab method.

The chief interest, however, of the oxy-acetylene process at present is confined to welding, which can be used in innumerable ways in connection with the construction of automobile frames and engine parts. It is probable, for example, that nearly all of the riveted joints in frame construction can be eliminated, and the pressed steel cross frame members, gusset plates and sills be united by the welding flame, so as to form practically one solid piece. Pressed steel, drop-forged or wrought iron step hangers, brackets for jack shafts, springs, guards, etc., can be neatly and readily made one with the frame. Drop-forged or cast steel spring horns can be firmly united to the pressed steel side members of the frame, and whatever cracks or unsightly joints might ordinarily be left, these can be completely filled and dressed off, making a much more finished job than by the usual methods.

At the same time the structure is materially strengthened. Many parts such as steering arms, pedals and levers, which are now either pinned and brazed, keyed or screw and nut retained, can be made to form one solid piece by a brief application of the welding flame. Parts which require mild steel centers but should have high carbon steel rims, as in the case of gears or gear sectors, can be built up by the use of this process. Brass handles can be joined to steel shanks, or brass heads be put on screws which need steel shanks for strength. Nickel steel or cast iron valve heads can be attached to carbon steel stems, and many other possibilities will suggest themselves to the minds of those actively engaged in automobile construction. I do not state that all these suggested uses will be found more economical than bringing about the results in some other way, but these are matters which will adjust themselves in practice. In the construction of radiators and tanks and the attaching of pipes to similar or dissimilar metal tanks, the oxy-acetylene process will doubtless find large application, as by this means absolutely seamless tanks can be formed which are actually stronger at the united edges than at any other place, owing to the filletting with additional metal.

#### Suggested Improvement for Auto Construction.

Automobile construction has shown a steady but gradual increase in the use of pressed steel parts, and it is but natural to suppose that by means of such a process as autogenous welding, the applications of pressed steel will become even more numerous. Already in Germany, patents have been granted for making light crankshafts from two similar pressed steel halves, united by the oxy-acetylene flame, and attempts have already been made to form axles in a similar manner, but I believe thus far the work has only been of an experimental nature. The following is a suggested method of forming a light pressed-steel piston. The walls of this piston consist of a rolled up sheet of metal, grooves or depressions for the piston rings in the same being produced by dies or rolling, while the free edges are

united by the flame. In the same way a disc head, which may be drawn to form a convex surface, and also drawn bosses, can be welded in place, giving an extremely light, rigid construction. Of course, it is understood that a slight amount of turning and finishing of piston ring grooves, holes for the wrist pin, and external grinding will be required. Light, stiff pressed steel connecting rods could also be made in a somewhat similar manner.

**Extensively Used for Repair Work.**

As it is possible to unite many dissimilar metals, and with a heat so localized that neighboring parts are not affected, autogenous welding has already found extensive application in automobile repair work. Broken crank cases or other parts can be

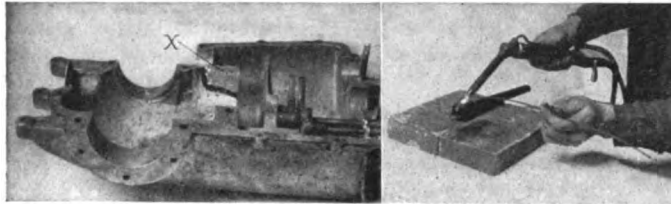

Fig. 3.—On the right is a view of an operator welding a spoke, and on the left is an aluminum gear case, the entire portion of which at X above the black line was built up from a bar of aluminum, thus providing an inexpensive method of remedying what has all along constituted one of the most costly items of maintenance to the autoist, replacing gearboxes and crankcases.

united and made practically as strong as new. The method of holding the pieces of a broken aluminum case, for example, is to clamp them into position temporarily while clay is packed around the parts and heated sufficiently to drive out the moisture, thus forming a solid support for the parts as well as a kind of mould. A series of holes are usually drilled at the crack, or the edges of the pieces are roughly beveled so, as previously explained, the metal can be built up from the bottom. In some instances lugs or peculiar shaped projections may have been completely worn off or destroyed when it becomes necessary to build up new ones with additional metal. A repair of this kind is shown in Fig. 3. In repairing a cracked water jacket, after the edges of the crack have been prepared, it is customary to use copper instead of iron wire for the filling metal as it flows at a lower temperature and adheres very positively. In case there is danger of warping, due to local expansion, the entire cylinder is heated before operating upon it. This preparatory heating process is also used on large parts, whose mass is sufficient to conduct away the heat so rapidly that it would otherwise be impossible with a flame of ordinary size to bring the parts to the melting point. In fact, the heat conductivity of large masses of metal is really the limiting factor in determining the size of work upon which the flame can be employed. Defective castings which ordinarily would immediately be consigned to the scrap heap can be made as good as new. Blowholes and other imperfections in large work can be easily filled, either with iron, brass, bronze or aluminum, according to the nature of the casting. With such a process perfected, there is almost no excuse for any metal part of a machine being discarded, whether in the original process of manufacture, thus eliminating much of the expense due to "wasters," or after a car has suffered an accident, avoiding the cost of high-priced replacement parts.

**Comparative Cost of the Process.**

The cost of oxy-acetylene autogenous welding depends, of course, upon the size of the work, the price of the gas, and in no small degree upon the skill of the operator, so that very little can be definitely stated in regard to it. It is claimed that the expense of uniting sheet metal can be compared with riveting as follows: up to 1-4 inch in thickness it is cheaper than riveting; 1-2 inch about the same, while above 5-8 inch it is more expensive, the cost increasing approximately as the cube of the thickness.

The time required for cutting different thicknesses of metal from experiments made by the Baltimore and Ohio R. R. Co. is as follows:

**CUTTING RECORDS.**

- A section 13 1/2 inches was cut from a 1/2 inch flat in 1 min. 10 sec.
- A section 12 inches was cut from a 3/4 inch flat in 1 min. 25 sec.
- A section 12 inches was cut from a 3/4 inch plate in 2 3/4 min.
- A section 33 was cut from a 15 inch x 50 lb. beam in 3 min.

The consumption of acetylene and oxygen by burners suitable for different thicknesses of metal are given in the appended table:

No.	Acetylene	Oxygen	Thickness of Metal
No. 1.	100 litres 3 1/2 cubic ft.	4 1/2 cubic ft.	1-32 in. to 1-16 in.
No. 2.	150 litres 5 1/4 "	7 "	1-16 " 3-32 "
No. 3.	225 litres 8 "	10 1/2 "	3-32 " 1-8 "
No. 4.	350 litres 12 1/4 "	16 1/2 "	1-8 " 1-4 "
No. 5.	500 litres 17 1/4 "	23 "	1-4 " 5-16 "
	750 litres 26 1/4 "	35 "	5-16 " 7-16 "
	1000 litres 35 "	47 "	7-16 " 1-2 "

For 3-4-inch metal a special tip of a capacity of 52 feet or 1,500 litres of acetylene and 71 feet of oxygen is required.

**FACTORY TESTING OF AIR-COOLED ENGINES.**

Not the least important item in the manufacture and marketing of an automobile to-day is the testing of the motor before mounting it on the chassis and the progress that has been made in this field has kept fully abreast of improvements in design and construction by those progressive manufacturers who will not let a car leave their works until certain that it has tested right up to the mark they have set for their product. An instance of this is to be found in the new dynamometer testing plant recently installed by the Oscar Lear Automobile Company, of Springfield, Ohio, builders of the Frayer-Miller air-cooled automobiles and trucks.

The apparatus consists of several stands upon which any size of engine may be mounted and one upon which is hung a Sprague dynamometer. This machine is ball-bearing, has its fields separately excited, and when loaded by means of a water rheostat near by gives an absolutely exact reading of the torque exerted by the engine expressed in pounds. A Schaeffer & Budenberg tachometer set on a stand next to the dynamometer and belted to it registering the number of revolutions. A chart on the wall then enables the operator to read the exact horsepower delivered by the engine. The dynamometer is so wired that it may be run at first as a motor to start the engine and is then converted by throwing the switch into a dynamo. All computations are checked up by a voltmeter and ammeter on the switchboard.

The apparatus also includes a Schultze manograph, imported from France. This delicate machine transfers to a photographic plate an indicator card for each cylinder. These on being developed will immediately show any defect in the engine such as loss of compression, poor firing or bad mixture, etc. The process is one of exceptional interest to the mechanically bent layman, as well as to the experienced engineer. These tests are rigidly carried through at all times and it is safe to assume that when an engine is delivered from the test room that it is not far from being all right.

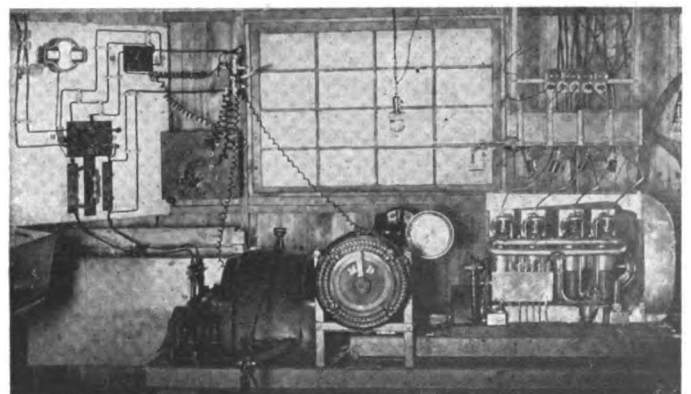

View of the Frayer-Miller Testing Plant.



## A POINTER ON REPAIRING BROKEN PARTS\*

WE all must admit that the machines of to-day are far superior in quality to those of former years. Some of us, when starting out for a certain point, are cocksure to get there at a certain time, others reasonably so, and still others are mighty glad if they get there at all. The fact that a good many more now reach their destinations than in former years is, no doubt, largely due to the fact that we have better cars. The manufacturers have learned by experience to proportion the different parts so as to better withstand the severe strain and wear to which they are subjected. Owners and chauffeurs also have benefited by experience, and handle and treat the cars to better advantage and with more consideration.

But one main reason why we have better success with our autos is due to the fact that better materials are being put into the running gear and the motor. For these better materials we are indebted to the scientist, who is forever and persistently searching into the unknown. For instance, when speed is wanted, friction in the running gear being objectionable, ball bearings were resorted to. When the balls in that bearing were found to break too often, rendering the bearing impracticable, somebody spent years and hundreds of thousands of dollars to find a steel for that particular purpose, and by the assistance of the metallurgist succeeded. While their particular steel would answer for ball bearings it was not at all suitable for other purposes, where tensile strength together with great elasticity or high vibrating break limit was required. Some other fellow with a long head gets to work and produces a nickel-steel, another with perhaps still a longer head brings us chrome-nickel steel, and still another vanadium steel, etc. When we find that these, or at least some of these different, high-quality and very desirable materials are excellent for our purpose, but are very obstinate and resist being worked into shape and finished with our old-fashioned tools, another metallurgist looms up with still another steel which cuts the first named just as easily as if they were ordinary iron.

But in spite of all these good materials, we cannot and do not expect that none of them will not break by accident or otherwise. And here we find a chemist who has discovered a flame hot enough to melt broken parts together, uniting them into a stronger unit than we had before it had been broken. This last discovery we believe does prove interesting to the automobilist, and for this reason we wish you to know of it. We do not wish to be understood to say that all these improvements were made on account of the automobile, but we do believe that it has been a large factor in the furthering of science in the direction spoken of. Going back to the flame, it is the hottest ever produced, and the heat compares favorably, if it does not surpass, that of the electric arc. The pyrometer puts it at 6,300 degrees Fahrenheit. It is produced by the combination of oxygen and acetylene gas in the same manner as the oxy-hydrogen flame. It is also used in the same way as is the last named torch.

You have probably seen the storage battery maker use a torch with oxy-hydrogen gas in burning the lead terminals or connections between the several cells together. The oxy-acetylene torch produces, according to its size and the purpose used, a flame consisting of an outer mantle and the exceedingly hot but small and pointy inner core. When the core of this flame is played on to a piece of steel, cast iron or any other metal, the surface melts immediately under the terrific heat. The end of a steel wire or rod of suitable thickness (depending on the size of flame and job in hand) may be brought into the flame when it melts and flows on to the molten surface, and unites therewith thoroughly. In that manner cast iron, aluminum, brass, even steel and cast iron can be united. In case of a broken axle, steering knuckle or any other part where the pieces must be budded together

closely, the flame would not get into the break far enough to make a good job. In such a case the operator cuts enough material away so as to make a wedge-shaped opening, enabling him to melt both surfaces, adding steel to fill it up from the bottom and make a perfect weld. If the mechanic is an expert with the torch he will succeed in uniting the broken part and heating it to a red heat not further than perhaps one-half of an inch distant from the break, so that a hole or screw located within that distance will not be disturbed, and a pin or nut fitting such hole or screw previous to the breaking will do so after the repair has been done.

Not only the steel parts can be repaired quickly and effectively, but the aluminum crankcase, as well as a cylinder, a lug or any other part, which, although inexpensive cannot be obtained quickly, can be made good quickly and satisfactorily.

The writer has seen quite a number of repairs so made. One, for instance, was a front axle on which the lower member of the fork receiving the steering axle was broken off. A new axle meant an expense of about \$75. It was repaired with the flame in less than an hour, and cost \$2.50. The thread in the hole, less than three-quarters of an inch away from the break, received the screw without difficulty. The axle is just as good as it ever was, and a little stronger in the place where it had been broken.

Another but less serious case was the breaking in two of a malleable iron exhaust elbow casting. A new elbow could have been bought for \$1.50, but it not being in the stock of the agents, a delay of ten days was probable. One dollar paid for the welding of it and it was none the worse for looks.

Your committee has reason to believe that the knowledge this article is intended to impart, meager as it may be, will prove of interest and perhaps of real value to at least some, who are so enthusiastic of our machines and their mechanisms that the automobile is the first, the intermediate and the final subject of conversation whenever we meet.

EDITOR'S NOTE.—Evidently Mr. Weiss and his fellow members of the Technical Committee of the Long Island Automobile Club have had occasion to see some of the results of autogenous welding, which is described more at length in this issue, in the shape of a paper read before the Society of Automobile Engineers at Detroit.

### THE "FRAME" RETURN A SOURCE OF TROUBLE.

One prolific source of faulty running lies in the frame return; there is no real advantage, says *Motor* (London), gained from it. On the contrary, bad connections can often be traced to it. There is only one correct way of arranging the return circuit, and that is to run an insulated wire from the metal cover of contact maker direct to switch. It is not good enough to attach the wire to a screw or bolt on the engine, as is sometimes done; the connection should be made direct to the contact sector. A well-designed contact device will always have a spring terminal provided for the purpose. In cases where the switch is fixed on the steering wheel it is just as easy to run two wires as one. If the return is intrusted to the steering column and the gear, the latter always in a more or less insulated condition with thick grease, it must be obvious that a very unreliable circuit must exist. Regarding the running of wires up the steering column, this is often done in an unsightly and unworkmanlike manner, the wire generally being tied on with adhesive tape. The method I would adopt would be to run the wires in a piece of polished brass or plated flexible tube neatly fixed on the steering column with clips. I recollect completely curing a very bad case of misfiring on a large four-cylinder car by temporarily joining the cover of the contact maker by means of a piece of flexible cable, later on substituting a permanent return to the switch. Previous to this the firing had been very "jumpy."

\*Paper presented before the Long Island Automobile Club by the Technical Committee.

## LETTERS INTERESTING AND INSTRUCTIVE

### EFFECT OF WHEELBASE ON SKIDDING.

Editor THE AUTOMOBILE:

[1,433.]—I understand that a lengthened wheelbase is an advantage in that it provides more room, greater comfort for the passengers by having the seats between the two axles, and also contributes greatly to the ease of steering. I contend that it is also an advantage in that it tends to lessen skidding. My contention is based entirely on personal experience in handling short and long wheelbase cars, but a friend holds the opposite view, and while each of us has advanced a great many reasons why it should or should not be so, I have been unable to arrive at any definite conclusion as to the cause, though none of the arguments of my opponent have been sufficient to shake my faith in the belief that the long wheelbase car does not skid as badly.

Can you confirm my experience on this point and explain just why this should be so?

G. F. VALDEZ.

Colorado Springs, Col.

The long wheelbase car does not have such a decided tendency to skid or side slip as does its predecessor that was much shorter, so that the results of your observation in the matter are quite correct. Nor is the modern car afflicted with a far worse habit that the very short car of former days was subject to—that of spinning around on a greasy pavement when suddenly brought to a stop. The nearer to the center of the parallelogram marked by the four points of contact with the ground represented by the wheels that the weight is carried, *i.e.*, the mass or center of gravity of the weight of car, the less effect will it have in accentuating any tendency to slip. When the rear wheels slide around, as is usually the case when a skid occurs, the pivot of the lever around which the end of the car revolves, may be taken as the center of the front axle. Once the car starts to slip in this manner, it is evident that its momentum tends to keep it going in the direction in which its force has been diverted, and as is the case with a pendulum, it is obvious that the point at which this force is applied will determine the extent of the effect it will have in slewing the car around. That is, following out the simile of the pendulum, if the force be applied to a weight on the end of the latter, the lever will tend to swing violently. This is the case of the short wheelbase car in which the center of the mass of the weight was often near the rear axle, while the modern long wheelbase car can be compared to a pendulum the weight of which has been moved up to the center of the lever.

### INDICATIONS OF AIR VALVE TROUBLE.

Editor THE AUTOMOBILE:

[1,434.]—Please advise through "Letters Interesting and Instructive" what my trouble is. I think it is in the Schebler carbureter that I am using. It never gave any trouble in two years, but now something must be out of order. When I open the throttle slightly, the motor responds promptly; when the throttle is opened in full, the motor slows down and I have a loss of power.

Burlington, Ia.

Failure of the motor to respond to the throttle is doubtless one of the most exasperating forms of trouble that is to be met with in running a car. It is usually caused by an over-rich mixture brought about by a failure of the auxiliary air valve to open in accordance with the opening of the throttle so that the mixture which was satisfactory at low speeds becomes surcharged with gasoline, often in a more or less liquid state, due to the greater suction at the nozzle, which is not compensated for by a correspondingly greater amount of air. To test this, fasten the auxiliary valve of the carbureter wide open, or remove it altogether. Cover the opening with a piece of cardboard and move this improvised slide back and forth to correspond with the opening of the throttle, and note the effect on the motor. A little experimenting of this kind should suffice to reveal the cause of the trouble and the remedy should not be difficult to apply.

F. EDW. RUNGE.

### DO AUTOMOBILE FLYWHEELS EVER BURST?

Editor THE AUTOMOBILE:

[1,435.]—In big steam engines and power plants a more or less common form of accident that usually does a great deal of damage when it does happen is termed the "bursting" of the flywheel. In other words, it flies to pieces, due to the effect of centrifugal force acting on the heavy rim of the wheel. Sometimes this takes place without any warning whatever and without any apparent cause, but usually it is brought about by the failure of the governor to check the engine when relieved of the load. The engine then begins to race, and unless the steam is shut off by hand it reaches a speed far beyond that which the flywheel is calculated to stand.

Now automobile motors are frequently raced and are often made to run light at speeds far beyond their normal rating. I would like to inquire if cases in which the flywheel has flown to pieces in the same manner common in large stationary engines have come to light, and if this is really not a danger which should be guarded against by not allowing the motor to greatly exceed its usual rate.

CENTRIFUGAL.

Montclair, N. J.

So far as we know, there is only one case on record in which an automobile flywheel is known to have burst in this manner. The accident occurred to a Decauville car in Long Island City a little more than a year ago and resulted fatally to the passenger sitting beside the driver, a ten-pound piece of the rim of the flywheel coming up through the floor. The car had been stopped and the engine was about to be stopped, so it is to be presumed that, in accordance with the usual custom, it was being raced preparatory to the current being cut off. Doubtless it was due to a flaw in the casting. The custom of racing the motor is to be condemned under any circumstances, but this is the only case that has come to our knowledge in which it has resulted disastrously.

### ABOUT THE ECONOMY OF THE TWO-CYCLE.

Editor THE AUTOMOBILE:

[1,436.]—As the two-cycle engine makes an explosion every revolution, does it not use more gasoline in traveling a mile than the four-cycle engine of same horsepower? Doesn't it use up more batteries?

The Thomas-Detroit has an engine with a bore of 5 inches and stroke of 4.3-4 inches and is rated at 40-horsepower under the A. L. A. M. rating. If another engine had the same size bore and 5.1-4 inches stroke, would it not produce more horsepower? If this is so, the A. L. A. M. rating is not very accurate.

In what race, such as the Vanderbilt and Grand Prix, has Lancia won? In what races has he come in second during the last four years.

A CALIFORNIAN.

Newman, Cal.

The two-cycle engine does use more fuel than the four-cycle, as outlined in the answer to Letter No. 1,421 in last week's issue of THE AUTOMOBILE. The greater consumption is not so much due to the fact that the two-cycle motor makes an explosion for every revolution, in contrast with the missed stroke of the four-cycle, as it is to the fact that there is considerable retention in the cylinder of the exhaust charge, and that, despite the deflector, more or less of the fresh charge escapes at the exhaust. The two-cycle is also harder on a battery owing to the greater frequency of the demands upon it, but with improved methods of ignition, even dry batteries have been found to give very satisfactory service.

The A. L. A. M. formula is not intended as a means of arriving at accurate results in figuring horsepower, and it must be evident to anyone who has given the subject a thought that this would not be possible by any such simple means. The idea has been to make the matter as plain and easy as possible for the layman; in other words, it is a formula for "popular consumption," so to speak, and is not expected to give more than approximate results. It is based on a piston speed of 1,000 feet per minute, and it is said that the denominator, *i.e.*, 2.5, which is employed as the

divisor of the product of the square of the diameter of one of the cylinders, times the number of cylinders, has been arrived at as the average shown by a number of representative American motors.

We do not know that Lancia has ever won any of the big road races, although his daring work has made him a popular favorite on every occasion. In the Targa Florio, September, 1905, he came in third; in the Grand Prix, June, 1906, he was fifth; in the Vanderbilt Cup race, October, 1906, he was second, and he also gained the same position in the Targa Florio of last year.

#### ABOUT REMODELING A LIGHT SINGLE-CYLINDER.

Editor THE AUTOMOBILE:

[1,437.]—I have a single-cylinder 6-horsepower runabout, weight 1,000 pounds. Do you think I can improve my car by putting in a double-opposed 6-horsepower motor? Would it cause less vibration? The vibration is what I want to stop as much as I can; as it is now, the vibration shakes things loose. The car runs about 15 miles an hour on high gear. Would it improve it to lengthen the wheelbase, which is 66 inches? Is 6-horsepower sufficient for a car of 1,000 pounds, or should I have a 10-horsepower motor? Is the Bellfus 10-horsepower double-opposed air-cooled motor O. K.?  
JOS. SYLVESTER.

Jamaica, N. Y.

Six horsepower is very little for a 1,000-pound car, as cars weighing 2,000 to 3,000 pounds usually have five to six times that much. It would hardly be worth while to simply change the type of motor, except that the vibration would not be so great. The shaking caused by a high-speed, single-cylinder vertical motor is naturally excessive and the installation of a double opposed motor, which is not only very much better balanced, but also runs much slower, would be a great improvement on this score. We doubt if motors of the double opposed type are made as small as six-horsepower. Lengthening the wheelbase would also be found a great improvement, but in order to get the best result it would be necessary to add 30 to 40 per cent. to its original length as the latter is extremely short—in fact, we thought the low limit in wheelbase lengths was 72 inches for anything built within the last five or six years. A 10-horsepower motor would give very much better satisfaction than the present power plant. We have never had an opportunity to judge of the merits of the motor you mention. Before undertaking the work of rebuilding your car, which is what the proposed changes will amount to in the end, we should advise you to count the cost carefully, at the same time bearing in mind that the result will not be a new car by any means, although the amount spent on the reconstruction process might be almost sufficient to pay for a new car of much better make.

#### ABOUT UNIVERSAL JOINTS AND COUPLINGS.

Editor THE AUTOMOBILE:

[1,438.]—In reading over the specifications of new cars I note that the description sometimes states that one or two universal joints are employed on the driving shaft. At other times it is referred to as a "coupling." I would like to know if there are not a number of types of universal joints and if the term "flexible coupling" is used to indicate a different kind of joint altogether, or is merely another name for universal joint. Also, what is a "telescope joint."  
READER.  
Savannah, Ga.

There are quite a number of different types of universal joints and they play an important part in the driving mechanism of an automobile. Some of the better known are the Oldham type, consisting of three parts, such as two hubs with circular flanges, to be fastened to the adjacent ends of the shafts to be joined, and a third in the shape of a disk between them, this last being provided with tongues fitting in the grooves of the flanges; another simple joint is the Hooke, the shafts to be connected having forked ends secured to the four arms of a center cross. Besides these, there are probably a score or more of well-known types of universal joints, many of which are covered by patents here

and abroad. In the sense that they are used with reference to the automobile in this connection, the terms universal joint and flexible coupling are practically synonymous. In fact, it is quite customary to refer to the first-named as the Oldham coupling, and it is better known by that title than the other. A slip joint is a totally different device that is usually used on shaft-driven cars in order to provide for movement that cannot be compensated for by the employment of a universal, *i.e.*, longitudinally in the same plane as the shaft itself. When standing, the distance from the rear axle to the forward universal on the shaft is a fixed quantity, but due to the flexure of the springs or the dislocation caused by striking severe bumps, this distance is often lessened to the extent of an inch or two, and the slip joint is designed to provide for this. The shaft is usually made square for four or five inches at the end intended to form the joint, and this squared section fits into a corresponding square recess in the other end of the shaft. It will be evident that the two ends of the shafts may thus move relative to one another without affecting the drive. This is usually known as a slip or telescope joint.

#### DIFFERENT METHODS OF VALVE PLACING.

Editor THE AUTOMOBILE:

[1,439.]—Can you tell me how many different methods of valve-placing and operation there are in current use on different automobiles? What are the advantages and disadvantages of some of them, as, although I have only had an opportunity to note comparatively few, it seems to me that the matter is one that is susceptible of a great deal of variation, and doubtless this has been indulged in at one time or another by different designers.

FOUR-CYCLE.

Shenandoah, Pa.

There are probably a dozen or more distinctive types of valve-placing and operation, most of which are to be found embodied in the design of one or more well-known motors. Among these, the commonest are what are termed the "T" and "inverted L" types, the valves being placed directly opposite in the former case, two camshafts being employed, while all are on one side under the foot of the L in the other, and are operated by the same camshaft. Then there are valves in the head, operated by one or two camshafts along the base, or by one superimposed camshaft, each of these methods naturally being subject to various modifications. Two methods which differ radically from any of the above are the concentric type in the head and the type in which the valves are set horizontally facing one another in a vertical pocket extending from the cylinder, two air-cooled engines being built in this manner, the Frayer-Miller and the Cameron, while the concentric type mentioned is also a distinguishing characteristic of a well-known air-cooled motor, *i.e.*, the Franklin. As already mentioned, there are also a number of other types, though the majority of them are simply modifications and not distinctive arrangements.

Advantages are claimed for each different arrangement by its designer, but it would require too much space to go into these. It is generally conceded that a valve arrangement which permits of designing the combustion chamber with a minimum of surface exposed to the heat of the burning charge, and which allows the most direct ingress and egress of the fuel and exhaust, will show the highest efficiency.

#### A POINTER ON CHANGE-SPEED GEAR SETS.

Editor THE AUTOMOBILE:

[1,440.]—From my observation I have come to the conclusion that where that most important factor of the transmission of power in an automobile is concerned—the change-speed gear, practice has resolved itself into a comparatively few standards. These are the selective sliding gear, the straight sliding gear, the planetary and the friction type. Leaving the last-named out of consideration, I should like to ask a few questions concerning the positive types: (a) What are the advantages of the selective over the usual straight or progressive type that was so commonly employed a few years ago, and (b) selective is so much better, why do not all makers employ it? I have been informed by some

drivers that it is only to be found on cheaper cars and that it is entirely a matter of cost, but my experience does not entirely confirm this, as I have known it to be used on high-priced American cars, such as the Packard. (b) Why is the planetary used on some of the lower-priced cars instead of the sliding type? In small sizes, is not the latter cheaper to build, and are there any other reasons why it should not be preferred? **GEARS.**

Buffalo, N. Y.

(a) The chief advantage of the selective over the progressive type of operation, is to be found in the fact that it is not necessary to pass through any intermediate gears in going from a higher to a lower speed, or vice-versa. Cost has been the chief factor in deciding against it where the medium-priced car is concerned, although this naturally does not hold where price is not an object. It is a much more expensive gear set to build than the straight sliding type. (b) Cost is here again the chief controlling factor, and while the planetary gear set may appear to be a more expensive construction it is quite the reverse. The pinions and gears are always in mesh and can be made of much cheaper materials, as they do not have to stand the shocks to which sliding gears are subjected. The case may be made of iron, instead of aluminum, and this makes considerable difference in the cost. The planetary is much better adapted for the use of the novice, as it is not so readily damaged and will stand a great deal of abuse that would put a sliding gear out of commission. It is not used on high-powered cars to any extent, owing to the fact that it does not lend itself readily to providing more than two forward speeds without undue complication and weight, besides which it is always more or less noisy on the low gear and quickly tends to become more so.

#### HOW LOW A GEAR RATIO IS USED?

Editor THE AUTOMOBILE:

[1,441.]—As a matter of curiosity I would like to ask just how low a gear ratio some of the old cars have used. One does not realize how great an improvement there has been in the matter of the relative speeds of the engine and the car until one of the oldtimers, by which I mean a car produced prior to 1904, is encountered on the road. On their low speeds some of these early cars have the motor running as if it would shake itself off the chassis, while the car is barely crawling. What is about the lowest gear ratio used now? **BARTON HADLEY.**

Boston, Mass.

Some of the oldtime cars must have had gear ratios as low as 16 or 18 to 1, on the lowest speeds, for as you say they raced their motors at a terrific pace to get up hills that now are scarcely noticed, while the car itself hardly maintained a pace that would be termed a dignified crawl nowadays. Naturally, the chief reason for this was to be found in the fact that their motors would not carry the load otherwise. We do not know definitely just how low a gear has been employed, but think the above does not overstate the matter. The lowest gear ratios are now to be found on light cars using a planetary change speed gear-set, and probably get as low as 12 to 1. Three and four-speed cars using sliding gears average 6 to 9 turns of the motor to one of the wheels on the lowest speed, or reverse.

#### MAGNETO IS SUPERIOR FOR IGNITION USE.

Editor THE AUTOMOBILE:

[1,442.]—Kindly inform me whether a magneto, when used on a four-cylinder car, gives more power and speed than a storage battery or dry cells. **E. K. SCHULTZ.**

Philadelphia, Pa.

It is a matter of common knowledge that the magneto, whether high or low-tension, is very much superior to a battery of any kind for ignition purposes on a four-cylinder car. Several years ago, before battery ignition systems had been brought to the point of development they have since attained, the difference between the two systems of ignition was very marked, and it was nothing unusual to find that a car had a speed of ten to fifteen miles an hour greater with the magneto. It is also much more reliable than the usual battery system and, once understood, is very simple.

#### FOR BRIGHTENING UP ALUMINUM.

Editor THE AUTOMOBILE:

[1,443.]—While aluminum does not become dirty or tarnished in the same sense that other metals do, it is noticeable that after a certain length of time it takes on a dull and unattractive appearance, and I would like to know if there is not some way of restoring it that is simple and easily applied. Doubtless some light on this matter would be appreciated by other readers, as well as myself. **B. J.**

A dilute solution of sulphuric acid and water applied with a brush will usually serve to effectually remove any foreign matter adhering to aluminum and will also give it a brighter finish, closely approaching the original.

#### SPARK GENERATOR FOR BATTERY CURRENT.

Editor THE AUTOMOBILE:

[1,444.]—We are somewhat frequently asked by intending users of our spark generator if it will take current from a dynamo or magneto instead of from a dry battery, and it seems worth while to call the attention of your readers to the fallacy underlying this idea.

As a matter of fact, it is scarcely possible to get satisfactory results from a dynamo or magneto thus used, the reason being that the contact made by the spark generator is of such exceedingly short duration that the armature has not time to "build up" a current before the break. A battery is a chemical apparatus, and chemical action has no "lag," whereas a reasonable, though small, time is demanded to set the copper and iron molecules of the armature in electrical vibration. The Atwater Kent contact maker is designed for battery current, and it closes the circuit only just long enough to permit the spark coil to "build up," with no armature lag added. We are unable to say just how long contact lasts, but we do know that by retreating the contact screw it may be so shortened that the spark diminishes from  $\frac{1}{4}$  inch—its normal length—to  $\frac{1}{8}$  inch, or to nothing at all. In other words, there is no waste contact time whatever, and the battery is drawn upon only to the extent actually demanded for spark production. Our statement that six dry cells, of the ordinary 6-inch or 25-cent size, will last for 1,500 to 2,000 miles, is meant to be taken literally as a safe statement of what may be expected. Many users report double that mileage. Incidentally, the erosion of the platinum contacts and all the other wear and tear, is as small in proportion as the current consumption.

In view of the fact that an outlay of three to six dollars for batteries will in reality carry the user of a spark generator through an average season, we think most of your readers will agree with us that the complication of an added dynamo or magneto whose current fluctuates with its speed and is nothing at all when the motor is at rest, is not warranted by the imaginary advantage to be gained. **ATWATER KENT MFG. WORKS.**

Philadelphia, Pa.

#### RESULTS OF THE HAND GRINDING JOB.

Editor THE AUTOMOBILE:

[1,445.]—I was glad to note the letter from W. J. B. S. which appeared as No. 1,387. He is partly right and almost equally wrong, for I did do the job of grinding by hand and got as good a fit as one would on a machine, but the job is no boy's play by any means and requires care and time. I used plenty of both. The engine is giving at least 50 per cent. more power now than it did.

As to removing the emery, he was sure right. I took all the precautions I could to get every bit of it out of the cylinders, but there is plenty of it there yet. I simply could not remove it all, and the result is, I will have to replace two crankpins and bush two crankpin heads. I have, so far, had to take the wear up in the cranks twice, but I am still trying to get rid of the emery and am pleased to know that, in time, I will be able to get rid of it all, as the wear is not near as marked as it was at first. As far as the pistons still wearing is concerned, I do not believe they wear very much, as Mr. Sparenburg cautioned me particularly not to grind too much, and I think he must have known that a little wear would take place when the engine was run and, in this way, they would wear down to the right fit, which seems to be the case, as the cylinders are getting tighter all the time.

I think this is a very good plan to grind old cylinders, but the emery is certainly a sticker, and I am still after it. In cleaning, I used gasoline, and was informed by an old engineman that I should have used kerosene, which I will try as soon as I have the engine down. I found that by putting graphite in the crankcase I got rid of the emery faster than any other way, as it would collect the emery and carry it to the bottom of crankcase when I could wash it out and put in new oil. After repeating this several times, I found it got rid of most of the emery.

West Liberty, Ia.

V. R. LANE.



## PERFECTING THE SURFACES OF FRENCH HIGHWAYS

PARIS, June 17.—French roads, already reputed the best in the world, could be made perfect by the use of small granite paving stones on a concrete foundation where traffic is intense, by the tarring of all main highways, and generally by the use of harder stone than are now employed by the government road makers. The opinion is that of Dr. Guglielminetti, president of the Anti-dust League, and one of the greatest authorities on road making that Europe can claim.

The paved roads which Dr. Guglielminetti proposed have nothing in common with the old pavé which earlier centuries have handed down to modern France. The idea of authorities is to reopen these old roads to modern circulation by pulling up the old blocks, making a solid concrete foundation, then paving with smooth, closely fitting granite blocks. Such a surface is declared to be the ideal for intense automobile traffic, for it is practically dustless, has the maximum of resistance, and does not set up vibration. Naturally the first cost is enormous and it is for this reason alone that the improved granite road will never be generally employed in France. On most of the old highways running from Paris, however, it has been decided to remake the roads on this system. At present these roads are paved with large, uneven blocks having such a disastrous effect on an automobile that it is folly to attempt to run over them. The consequence is that the widest roads out of the city are neglected by automobilists; all the traffic is driven to the narrower macadam highways, which are unable to withstand the terrible strain. When these roads have been relaid Paris will have a set of out-

lets unequalled for fast motor traffic by anything in the world.

A very large amount of tarring is now being done on French roads, practically every village around Paris having undertaken to treat the highways in this manner. Thus on the main roads, where villages are close together, there are frequent stretches of ten miles of tar-treated roads; the roads from Paris to Versailles, carrying an immense amount of automobile traffic, and formerly as dusty as it is busy, has now been entirely treated with tar, with the result that even on a crowded Sunday afternoon no dust whatever is raised.

Where heavy traffic necessitates it the tar treatment has been applied even in the open country. The forest of Fontainebleau is an instance of this, some of the main highways through the forest being treated with tar for distances of ten to twenty miles.

One of the dustiest roads in France which has been perfected by tar treatment is the Corniche between Nice and Menton. Here during the busy season more than 500 automobiles pass in a day. Instead of a pestilence the highway is now a dustless boulevard. This southern stretch of road has been subjected to the severest possible strain, for the traffic is intense and fast and the material not of the best. It has been proved, however, that when the tar is applied on scientific lines it not only entirely removes the dust evil but gives a much more resisting surface. Where the tar treatment has failed in France it has been entirely through neglect to follow known rules in the treatment of the roads, and the process is now being carried out in a manner that leaves nothing to be desired.

## TRACTORS SUPPLANTING MULES ON FRENCH CANALS

PARIS, June 17.—Although England has made some experiments with automobile barges on her northern canals, the honor appears to belong to France of first seeking to supplant the leisurely horse from the towpath of the inland waterways. The first tractor of this kind is employed on the Bourgogne canal connecting the River Seine with the Saone and thus linking up the Channel port of Havre with the Mediterranean naval station of Marseilles. The canal, which is 150 miles in length and has 189 locks, has up to the present been passed by means of teams of horses, four being employed for the trip, two resting on board while two are occupied in hauling. Under these conditions, the boats traveling day and night, the trip usually occupied four days.

As the towpath was in excellent condition, the experiment was made a short time ago by the Compagnie Générale de Navigation of supplanting one set of horses by an automobile tractor. The machine selected is a four-cylinder 10-horsepower Cottereau mounted on a special chassis equipped with metallic wheels. The

power is transmitted through a leather-faced cone clutch to a three speed gear box and countershaft placed to the rear of the axle, final drive being by means of side chains.

As a fully loaded barge weighs about 200 tons, the 10-horsepower motor is manifestly too little for starting such a vessel up from a rest. The rear wheels are ribbed to give increased traction, but even with this there is a considerable amount of slip before the heavy vessel can be got under way. Once moving, however, the automobile tractor has no difficulty whatever in maintaining a speed of five or six miles an hour, thus effecting a considerable saving over horse traction. An engine of about 16 horsepower would doubtless be better fitted to handle the heavy loads, but this would give excess of power under normal going and a consequent increase in gasoline consumption. The value of the innovation lying in low working cost. A contemplated improvement is the use of a low-geared winding drum operated by the engine, to be used solely for starting the barge.

## COL. SOHIER MASSACHUSETTS HIGHWAY COMMISSIONER

BOSTON, June 22.—An important change has been made in the Massachusetts Highway Commission, the State body which has in charge the administration of the automobile laws. By the appointment of William E. McClintock, who has long been chairman of the Highway Board, to the position of chairman of the commission which is to govern the burned city of Chelsea, a vacancy was created. The acting Governor named Harold Parker, a member of the board, to become chairman and appointed William D. Sohier, of Beverly, to the vacancy. Colonel Sohier is an automobilist who takes a great interest in motoring affairs. He is president of the Safe Roads Automobile Association, an organization that has done much to compel respect for the motor vehicle laws of this State. It is not an anti-automobile

association, but is composed of owners of cars who believe in the reasonable use of the roads and the suppression of reckless driving. The new automobile bill which the present legislature is expected to pass was drafted largely by Colonel Sohier. He is also a good roads enthusiast and, as chairman of a committee of North Shore summer residents, has had charge of the expenditure of large sums of money privately subscribed for road work. It was he who introduced the use of calcium chloride as a dust layer in this part of the country, and who has taken a leading part in experiments with oil and other road preservatives. The automobilists are well satisfied with the appointment of Colonel Sohier to the board, for they believe that their interests will be advanced by his official actions.



TO the inexperienced observer, the Packard "Thirty" for 1909 is just Packard, and probably to those who are familiar with its distinguishing characteristics, this suffices to describe it better than anything else possibly could. As the result of the consistent adherence of its builders, the Packard Motor Car Company, Detroit, Mich., to the policy of devoting the entire energies of its engineering staff and huge plant to the development of a single type of car, it has been possible to say this of the Packard car for the past four or five years, for, although a comparison of the latest Packard representative to uphold the name, with its predecessor of four or five years ago, would reveal startling differences, the process of evolution has been so gradual as scarcely to be perceptible to any but the observant eye that sees far more than a casual glance reveals.

Nor has this process ceased, as even the 1909 model of the "Thirty" has distinguishing features of its own. Doubtless the first of these to be brought to light is the disappearance of the short independent lever to operate the reverse of the gear-set, and at first glance it appears as if the principle that the Packard builders have adhered to without change, despite the almost universal trend of both foreign and American practice, had finally been abandoned. That is, the use of a progressive three-speed sliding gear-set, instead of the selective type now so generally employed. The new gear-shifting lever on the latest

model shows that it is intended to be worked selectively, although there is no "H" sector, or gate, as is commonly employed on the majority of cars using this type, and at a casual glance one would be apt to say that the Packard designers had finally been won over. Investigation shows this not to be the case, however, as the three-speed sliding gear of the progressive type has been retained intact, and moreover, its method of operation is still the same, the shifting lever merely being worked selectively in order to employ the reverse, thus doing away with the small third lever which has been a Packard feature for so long.

There are likewise some minor changes about the motor, but they are such as only to be revealed by an actual comparison of the details of the 1908 motor and its successor. For instance, the idler gears between the crankshaft and the two to one pinions on the camshafts have been eliminated by making the driving pinions that much larger, this change conducing to a much simpler arrangement and making the motor even more silent running than previously. It will be noticed further that the crankshaft no longer protrudes through the crankcase forward, but the shaft of the starting crank has been designed to enter the crankcase to engage with the main shaft, thus permitting the use of an entirely oil-proof joint. Roller bearings have been substituted for ball bearings in the front wheels and the steering arm has been shifted to run over the axle instead of under it as

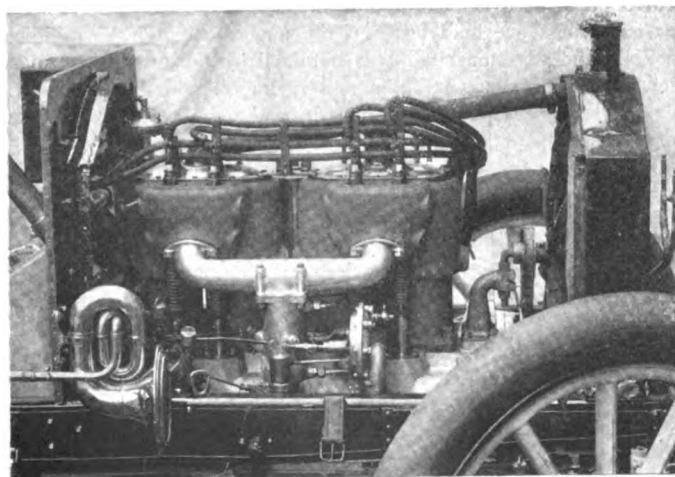

Showing the Packard Carburetor and Hydraulic Governor.

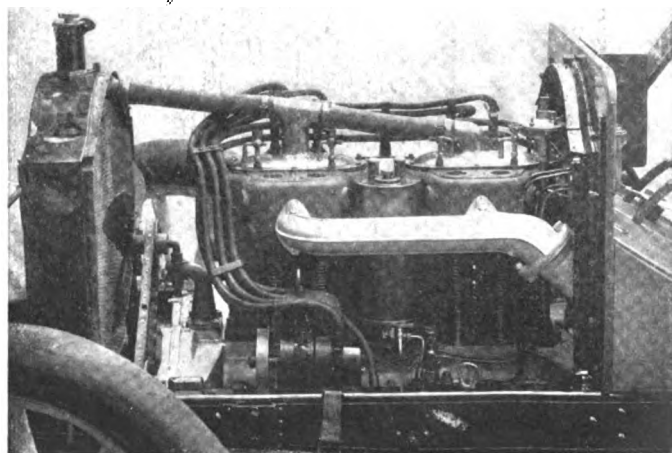

Packard Magneto, Oil Tank and Oil Pump for Lubrication.

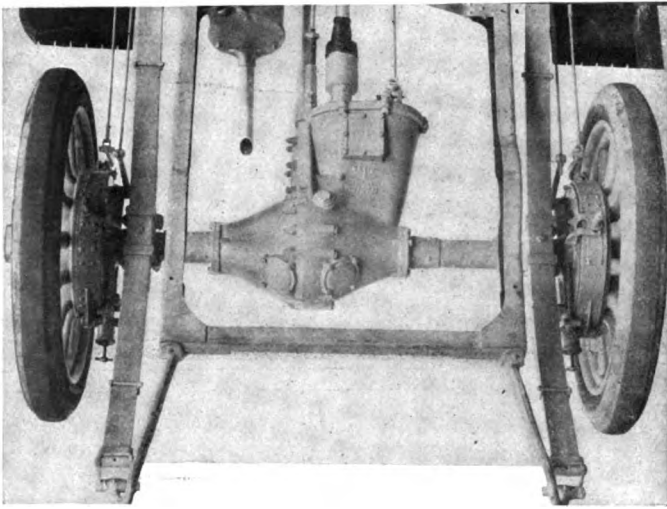

Rear Axle Driving Unit of the 1909 Packard "Thirty."

previously. Experience has shown that the polished surface of the rear face of the front seats is the first to suffer from scratches, and it has accordingly been upholstered the same as the remainder of the interior of the tonneau, instead of being painted, as is usually the custom, another slight change in the body equipment consisting of the use of a paneled door. The forward mudguards have also undergone a slight alteration, as will be apparent from the photograph showing a forward view of the chassis, an integral flare or dropped piece having been added to prevent dirt being thrown out.

#### Little Change in the Power Plant.

Apart from those detailed refinements of the motor which have already been made mention of, it is difficult to find any changes of particular note in the design or construction of the power plant of the new Packard. The same familiar motor with its twin castings and valves in outboard ports on opposites of the cylinder head, worked by the direct thrust method, and which has done so much to earn for the Packard its reputation as one of the smoothest and quietest running of American cars, is retained practically intact. The cylinder dimensions are 5-inch bore by 5 1-2-inch stroke, and although nominally rated as being 30 horsepower, this motor will actually develop practically double that, so that even the Packard stock touring car with full equipment is capable of a mile a minute or better on a good road. The castings for the cylinders, exhaust manifolds, pistons and piston ring blanks are all imported from France, being made of a special grade of gray iron for this purpose. These are

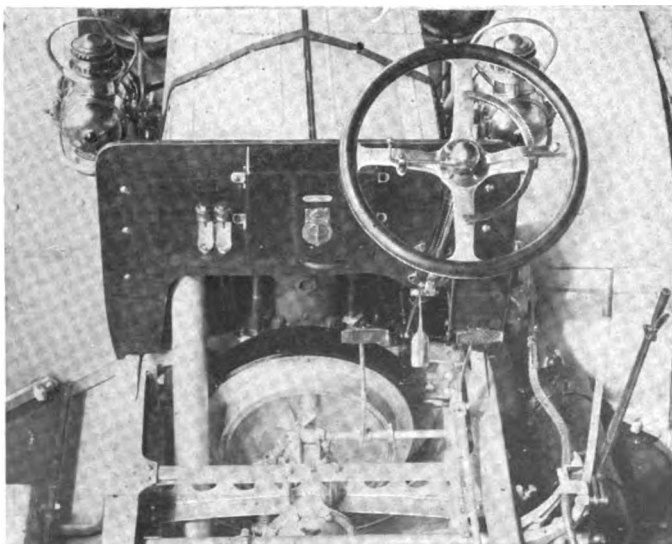

Neatness and Accessibility of Packard Dash and Control.

brought over in the rough and machined at the Detroit plant, the pistons being accurately ground and fitted with four ground rings, while the cylinders, pistons and rings are lapped together with a polishing agent in order to obtain a perfect fit.

Parsons white bronze is employed for the three liberal-sized bearings of the crankshaft, the journals of which are ground to size, and which is noted for its extreme accuracy due to special manufacturing and inspection methods. The connecting rods are one-piece drop-forgings, the piston pins being bushed with Packard special bronze. The valves are oppositely disposed and are made interchangeable, operation being by the usual direct thrust method from camshafts inclosed with the crankcase, where they are fully protected from dirt and are certain of lubrication. One of the distinguishing features of the Packard motor where its accessories are concerned is to be found in the fact that the magneto and water pump gears as well as the timing gears are contained in a separate, but integrally cast, oil-tight extension of the crankcase.

#### Some of the Motor's Interesting Details.

The crankcase is cast of a special aluminum alloy in three horizontal sections, the uppermost serving as the engine base,

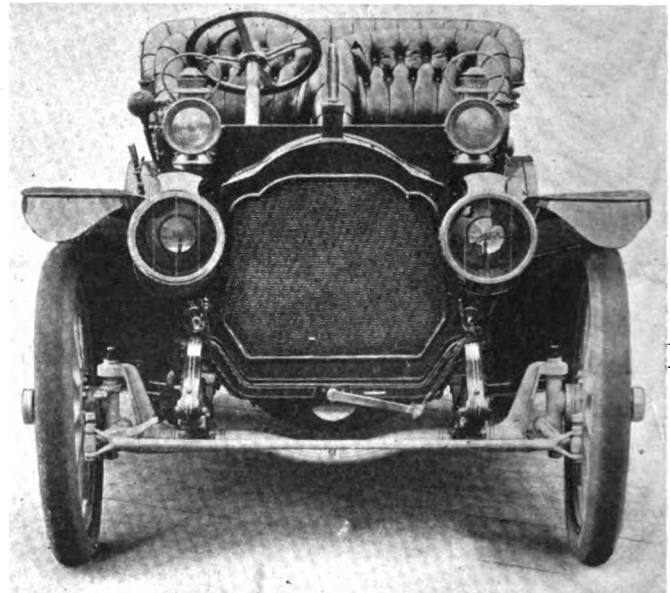

"Head-on" View of the Latest Packard Representative.

to which the cylinders are directly bolted and which in turn is supported directly on the side members of the main frame of the chassis. On each side of the motor, between the supporting arms, is a horizontal, integrally cast web, entirely inclosing the space between the motor and the frame, thus affording complete protection to both the motor and all its accessories. The crankshaft bearings are held between the uppermost and the middle-sections and extreme rigidity is obtained by the use of massive webs. The bottom section is merely an oil pan and is easily removable for the purpose of inspecting the connecting rod ends, main bearings or the camshafts without the necessity of disturbing any of the bearings. The crankcase is divided into front and rear compartments by partition supporting central bearing.

#### Features of the Motor's Accessories.

Coming to the motor accessories, the carbureter is of the special type evolved by the Packard designers and employed on this car for a number of years. It is of the usual float-feed, aspirating nozzle type with auxiliary air inlet, but has numerous distinctive features of its own. The cylindrical vertical mixing chamber has the nozzle situated in its lower portion, while there is a butterfly throttle above which is intended solely to control the quantity of fuel passing to the motor, but not its quality. The auxiliary air inlet consists of a poppet-valve controlled by:

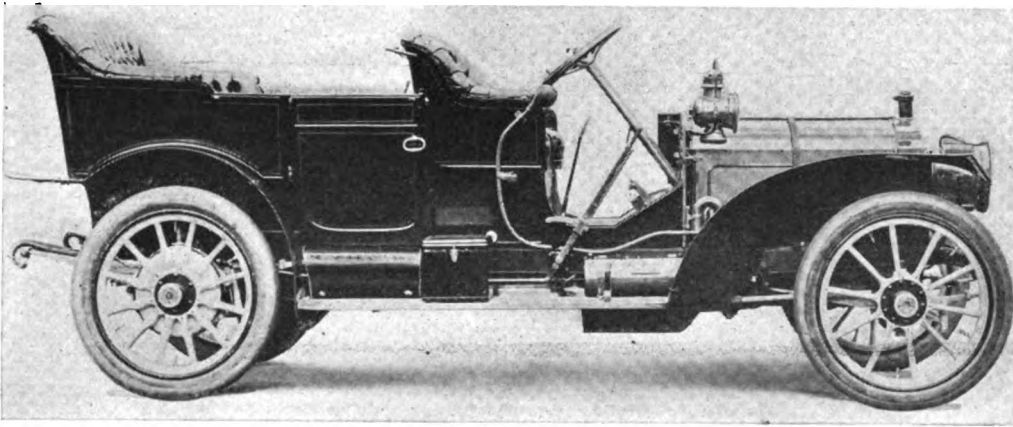

The Packard "Tout Ensemble" Shows Very Little Change in the "Thirty" for 1909.

an adjustable helical spring, and is designed to automatically govern the amount of air admitted to maintain the mixture practically uniform at all motor speeds. The tension of the spring may be altered to suit different atmospheric conditions, by means of a small lever situated on the dash. A uniform temperature is maintained in the carburetor by means of a water-jacket through which the circulating water of the motor is run, this jacket surrounding the mixing chamber. To facilitate starting in cold weather, there is provided a primary air intake shut-off.

The cooling water is circulated by means of a positively-driven centrifugal pump, a special feature of which is its hydraulic pressure lubricated thrust bearing. The radiator is of the usual cellular type long a feature of the Packard and its capacity is five gallons. The draft through it is forced by means of a belt-driven fan supported on an adjustable ball-bearing mount attached to the front of the motor base.

#### Dual High-tension Ignition Employed.

An Eiseemann magneto of the high-tension-with-coil type is employed as the main standby of the ignition system, and is supplemented by a set of Fulmen accumulators working a synchronized high-tension system through a single coil. The Eiseemann magneto is mounted on the left side of the motor bed and is gear-driven by means of inclosed pinions. The transformer coil for the magneto current and the single vibrator coil for the battery side of the ignition system are both contained in the same case mounted on the dash, with a single hand lock switch between. The timer for the battery primary current is located on a vertical shaft at the rear of the motor and is driven from one of the camshafts through inclosed bevel gears. The distributor, high-tension wires and the spark plugs are common to both systems. Universally jointed knife switches are employed for testing purposes.

For lubrication nothing has proved superior to the splashing of oil in the crankcase, and it is depended upon to effect this essential operation in the Packard motor. An oil tank holding one gallon is situated between the two pairs of cylinders in a location where the oil is maintained at a uniform temperature regardless of the weather. From this tank oil is pumped independently to the front and rear compartments of the crankcase, in each of which the level is maintained separately. For distributing the oil, a plunger oil pump having an adjustable stroke is employed. It is accessibly located on the left hand of the motor, and is driven by a worm on the ex-

haust valve camshaft. The oil passes through two sight feeds on the dash in passing from the tank to the crankcase, and the drains in the latter are fitted with anti-clogging devices that are properly located.

The motor speed is regulated by an effective and easily controlled hydraulic governor incorporated in the water circulating system and acting directly on the butterfly throttle, the governor being cut out of action by the usual pedal accelerator, although the throttle is also under hand control by means of the hand lever.

The first step in the transmission of the power from the motor to the rear wheels consists of the internal expanding type of clutch which has been a distinguishing feature of this part of the Packard ever since 1904. It is extremely simple, merely comprising a ring expanding within the flywheel rim and actuated by an adjustable screw and nut device. A long propeller shaft connects the clutch with the gear-set and is equipped with effectively incased universal joints at each end. The change-speed gear, the bevel gear drive and the differential are all inclosed in a common housing located on the rear axle, forming a neat and compact rear-axle unit. As in the 1908 model, which marked a change in this respect, the casing is internally ribbed, thus presenting a smooth outer surface, while hand holes have been provided for inspection. The differential gear unit is supported by its own bearings so that the live axles may be withdrawn without disturbing the gears. Three forward speeds are provided with the direct drive on the third. Gear shifting is easily accomplished on the progressive system, the actuating slide rod being annularly grooved to correspond with spring controlled spacing dogs, which determine the correct positions of gear engagement. By giving the shifting level a lateral movement, the reverse may be obtained.

Two independent sets of brakes housed in special drums on the rear wheels are employed, the external contracting set constituting the running brake for general use, while the internal expanding brakes are operated by the hand lever and constitute the emergency brake. A drum disc entirely incloses and protects each internal brake.

The steering gear is of the worm and sector type, the latter essentials being forged integral with their respective shafts, and a large, rigid steering column is employed. Any of the standard types of bodies such as the touring, roadster, limousine, as well as the new close-coupled type, are mounted on this chassis. In the case of the touring car, the list price of \$4,200 is now made to cover five lamps, a gas tank and the two extra tonneau seats.

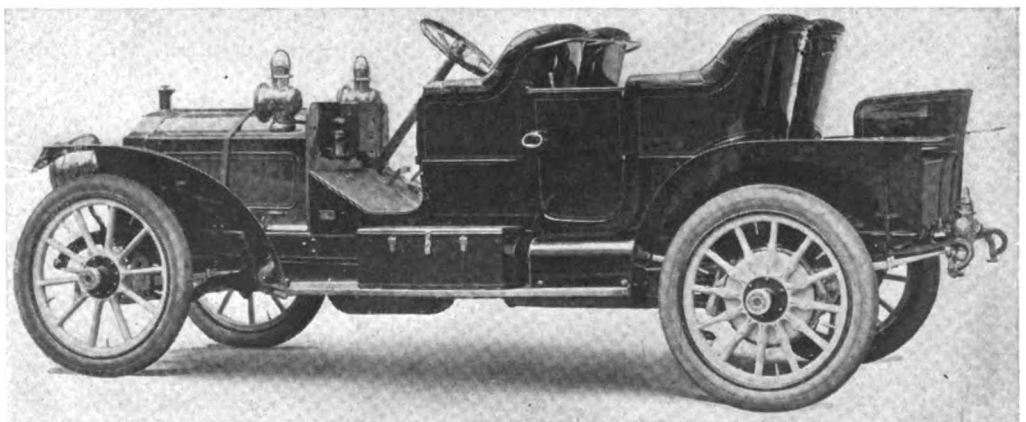

Close-coupled Body Originated by the Packard Body Department for the "Thirty" Chassis.



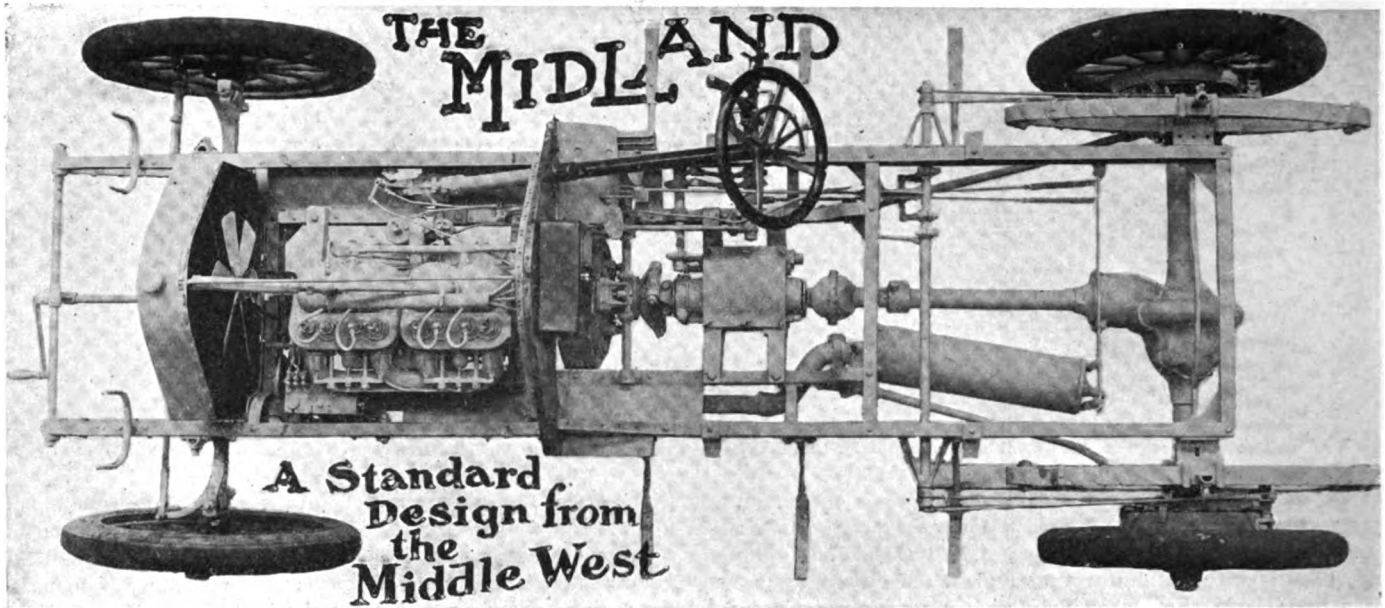

**T**HIS is a comparatively new comer, designed particularly to meet the demand of the large body of autoists who desire an up-to-date car with plenty of power at a medium price, and as the choice of its title indicates, it hails from what is fast becoming the automobile manufacturing center of the country—the Middle West. It is the product of the Midland Motor Company, Moline, Ill. There has been no attempt whatever to produce something radical or revolutionary in the shape of a car, as well recognized standards have been followed throughout where both the design and construction are concerned. The motor is rated at 30-35 horsepower and consists of two twin-cylinder castings with the valves all placed on the left-hand side. The cylinder dimensions are 4 1-2-inch bore by 5 1-2-inch stroke, and the motor has been designed to produce its rated output at a moderate, normal speed, although it is capable of exceeding the latter by a considerable percentage. Both the inlet and exhaust manifolds are held on by the same yokes and may be taken down simply by loosening a few bolts. One of the features of the motor is to be found in the extra shaft running along the valve side of the motor and which serves to drive the gear pump for the circulation of the cooling water. The ignition timer is set on a vertical standard close to the pump at the flywheel end of the motor.

Ignition is of the high-tension type, employing storage batteries and dash coil, while the lubrication is taken care of by a force-feed oiler delivering oil directly to the bearings and splash from the crankcase for the pistons and piston pins. The radiator is of the vertical, flat, tubular type and is placed entirely behind the

front axle, which serves to add greatly to the appearance of the car, besides bringing the load between the axles. For the transmission of the power a floating disc clutch equipped with large cork inserts is employed. It runs on roller bearings and is provided with a ball thrust bearing. There is a coil spring torsion shock absorber placed between the clutch and the change-speed gear-set and the former is also provided with a clutch brake to prevent spinning and which makes easy and noiseless gear-changing possible. The gear-set is of the sliding type, operating on the selective plan and provides three forward speeds and reverse. The gears are of nickel-steel of 1 1-16-inch face by six pitch and their shafts run on Timken roller bearings. From the gear-set there is a straight-line drive by shaft to the bevel gears in the rear axle driving unit, which is also equipped with Timken roller bearings throughout. A semi-floating type of rear axle is employed, while the front axle is a one-piece I-beam drop-forging, the wheels front and rear being equipped with roller bearings. The suspension consists of semi-elliptical springs forward and scroll-head full elliptics in the rear, while the brakes are of the external contracting and internal expanding type, located in separate drums on the rear wheels. The tire equipment is 34 by 4-inch on all four wheels, Marsh rims being fitted as part of the standard equipment. The frame is of the usual standard pressed steel construction, amply reinforced at the corners and braced by transverse pieces, the motor and transmission being supported on a sub-frame, as will be evident from the plan view of the chassis reproduced here.

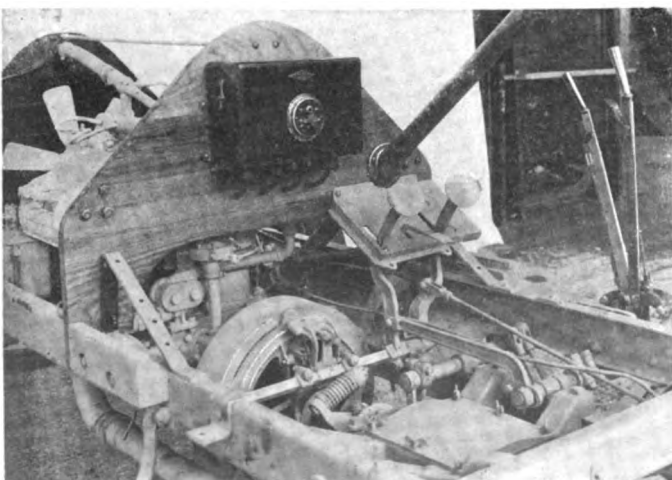

Details of the Midland Under the Footboards.

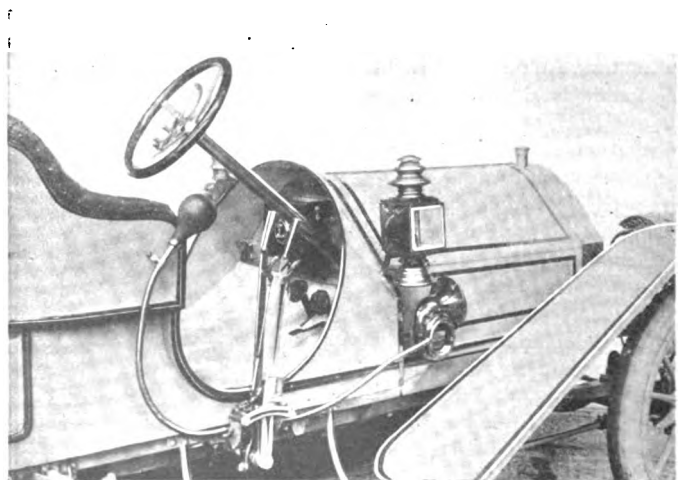

Quartering View Forward, Showing Midland's Neat Lines.

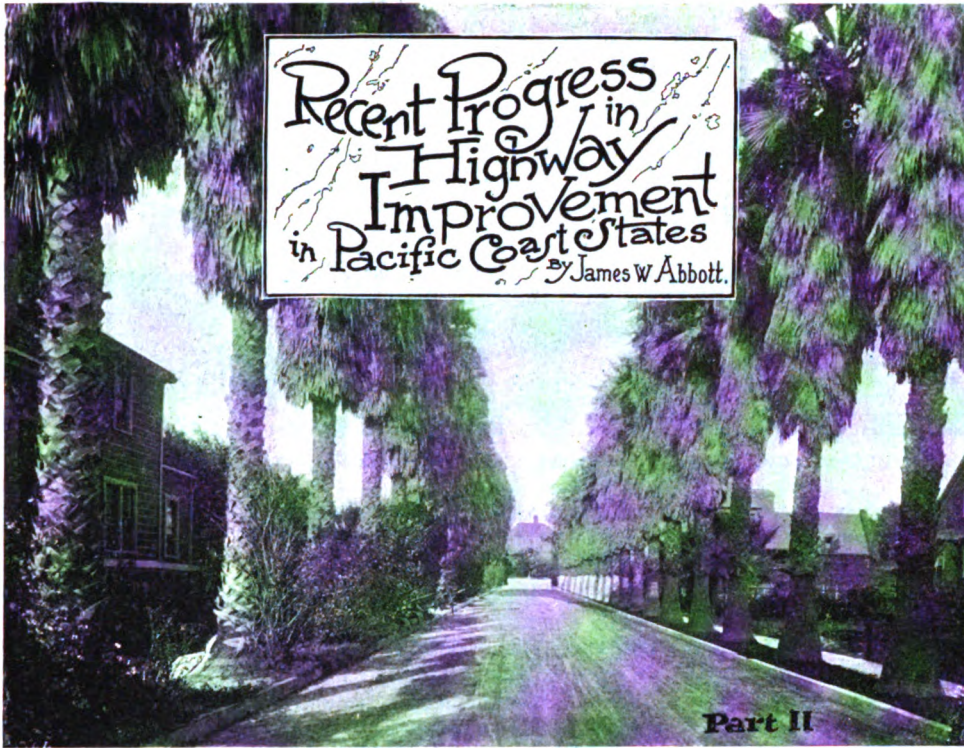

Highest Type of Oiled Highway in Southern California.

IN the previous article I described an incident which had just come to my personal attention. It related to an automobile, hopelessly mired on the great highway connecting two among the principal cities of Southern California: Los Angeles and Pasadena. I do not think any more disgraceful spectacle has ever been witnessed in any civilized country.

But I am pleased to say that the redemption of Southern California seems to me to be close at hand. Already the finest road for automobiles which I have ever seen—and I am inclined to think the finest which exists in the United States—has taken the place of that slough of despond.

In no other part of the United States is there such insistent need for a system of improved highways as in Southern California. In no other part of the United States is there such a high average standard of intelligence among all classes of people. The people of Southern California may not see things as quickly; they are not as alert as they are in other sections. But when they do see, they act, and they act with a unanimity and effectiveness unequalled anywhere else in the country.

The only exception which I can think of to the statement I have just made is the intelligence displayed by the people of the State of New York in voting \$50,000,000 in bonds for highway improvements in that State. This is far less for New York than will be the amount of money which will be realized in bonds in Southern California for road building within the next year, unless present signs fail. New York was educated up to this through a period of enlightenment which California never had had, and without the autoists New York would not have gotten its bonds.

This is not meant for invidious comparison, because I think that the action of New York was grand, and was of unspeakable value to the rest of the country; and it is quite probable that the example of New York was the most inspiring influence which actuated the people of California. Be all that as it may, the marvelous fact is as follows:

About the time that automobile of which I have spoken stuck in the mud on the Pasadena boulevard, the people of Southern California awakened to their need for improved highways. It

The first of the series of three articles by Mr. Abbott on "Recent Progress in Highway Improvement in Pacific Coast States," was published in "The Automobile," June 18.

seemed to be a vision which burst upon them almost as suddenly as that which hit Saul of Tarsus when he journeyed from Jerusalem to Damascus.

The Chamber of Commerce of this city called upon the counties of Southern California to send a representative delegation to meet in convention here and formulate a plan for relief. As the result of this convention a committee was sent to Sacramento to secure suitable legislation under which the work could be attempted. Considering the little time for digesting the subject, it is amazing to think how good a statute this committee succeeded in getting enacted.

It is impossible to quote this statute at length in this article. The gist of it is that it provides for the appointing in each county, by the board of supervisors of the county, of a highway commission for such county. As a condition precedent to the appointing of this commission, the board of supervisors must receive a petition

signed by the "freeholders electors of the county equal in number to at least 10 per cent. of the vote cast for governor in said county at the last election, praying that the matter of issuing bonds of the county for highway purposes be submitted to the electors of the county."

It is prescribed as the duties of this highway commission, so appointed by the supervisors, to prepare a map, outlining a system of public highways for the entire county. This highway commission is authorized, "with the consent of the board of supervisors, to employ, at the cost of the county, a competent engineer or engineers and other experts to make any necessary surveys, and prepare said map, and to assist the commission in determining the best material to be used and the best manner of making such improvements and the cost thereof." No restriction is placed upon the compensation which shall be allowed to the engineers or experts, thus leaving it open to the highway commission to secure the best advice obtainable.

When the map and estimates are ready, they must be approved by the county surveyor and supervisors, and when approved, the county supervisors "shall, without delay, call an election to determine whether the bonds of the county shall be issued in the amount recommended by the commission for the purposes stated in their report." Should the bonds be voted, then this highway commission continues to exist as a body until all of that money

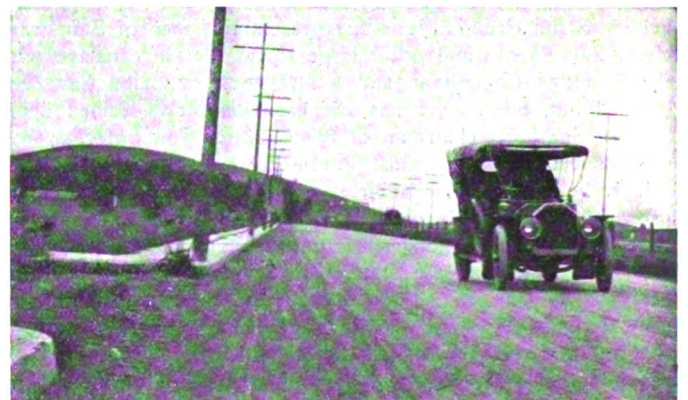

Outspeeding the Electric Car on Pasadena Boulevard.



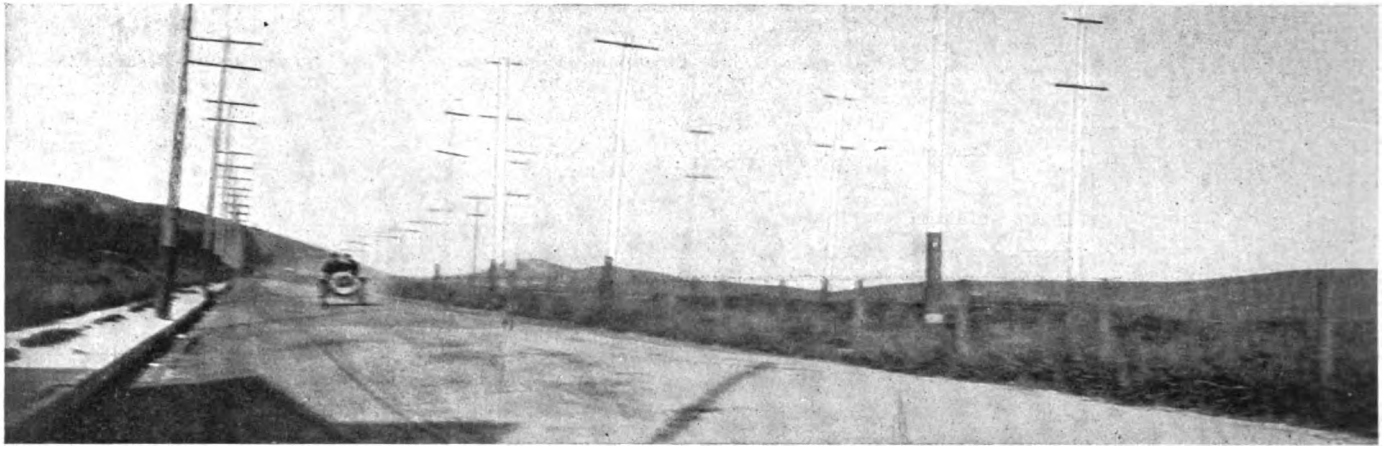

Fifty Miles an Hour in Southern California, Over Perfectly Constructed Roadway, Making Automobile Travel Ideal.

has been expended, when that commission shall become defunct. If the needs of the county at some future time require, another commission can be instituted in the same way.

Under that statute, for the enactment of which the agitation began but little over a year ago, the highway commission appointed, in pursuance of it, in Los Angeles county, has almost completed the prodigious task of designing a comprehensive system of highways for Los Angeles. The present plan is to recommend the issuance of \$3,000,000 in bonds to build 300 miles of road, of which, as provided by this statute, all shall be constructed "of a durable and lasting character."

The statute further provides that the macadamized or paved portion of the roadbed constructed on any highway or portion thereof, improved under this act, shall not exceed 16 feet in width, unless donations are made to the highway commission for that purpose, in which case such donations may be used to defray the increased cost of constructing such macadamized or paved roadbed more than 16 feet wide, on any part of said highway specified by the donors. I believe that such a record of diligence in any highway undertaking has never had a parallel.

It is the expectation of the Los Angeles County Highway Commission to be able, before this article can appear in print, to submit their final report to the board of supervisors, and ask that the bond election be called immediately. It is believed that the election will carry, and that this \$3,000,000 will produce a system of highways more nearly approaching the facilities of

that character in the Garden of Eden than any other ever attempted by human agency.

Other counties of this State are working as conscientiously as Los Angeles county, and within one year from now it is confidently expected by the advocates of good roads in California that every county down the coast from Marin to San Diego will be at work upon its respective highway system.

One of the conspicuous features of this plan will be for each county to have a piece of road which shall be a portion of that great highway to be built down this coast.

Already there is a very strong sentiment growing in the State of Washington for the greater highway to run from Blaine to Tia Juana which shall be the Riviera of the Western world, connecting the British possessions on the north with Mexico on the south. When finished, it will be the most famous road on earth, and will tend to open up this Pacific coast empire as no other single agency could.

Under the leadership of Judge Webster, Oregon will get lined up on a plan to utilize its convict labor for road building, and will arrange that these convicts shall work on the north and south road through that State, which shall be a portion of the through highway. Just how Northern California will look at this matter, and just how results there will be effected no one now can predict. But those who know the spirit of the Argonauts will not doubt that California will be equal to the emergency, and will not fail to justify her traditions.

## CALIFORNIA AWAKE TO IMPORTANCE OF ROAD IMPROVEMENT

SAN FRANCISCO, June 18.—The people of California have awakened to the realization of the value of good roads, and an active movement is on foot, backed by influence, money and the power of the State, which is sure to culminate in nothing less than highways worthy of the State. At a meeting of the Counties Committee of the California Promotion Committee, held in Santa Cruz on June 6, representative men of San Francisco, Sacramento and other large towns met in conclave with the Counties Committee, and a strenuous campaign has been mapped out, but as yet has not been definitely decided upon. Andrea Sparboro, chairman of the Counties Committee, opened the convention with a most interesting speech. Among other things, he said: "Our subject, to-day, might really be more properly entitled bad roads, because, unfortunately, so far we have more bad than good roads in our State, but we must consider that this is a new State, with a sparse population, being composed of an energetic and progressive people. It is now time that we take hold of this matter in earnest and see to it that our State is traversed in all directions by good roads. It only requires that we consider this from a practical business point of view. Every year we spend for repairing wagons and the purchasing of horses, and lately repairing automobiles, more than it would cost to keep our roads in the very best condition.

G. L. Morton, representing the United States Road Making Bureau, stated that the trouble of most of our roads is that they are built politically instead of scientifically.

L. P. Lowe, president of the Automobile Association of California, talked on the necessity of good roads from the automobilists' standpoint, suggesting: "Tax all vehicles and then have the money used for a road fund. I am sure that will bring the desired result, and no automobilist or wagon owner anywhere can object to such a tax, if he knew the money was going back into good roads for his use. Or let every interested man vote for good roads, if we can make it a political issue. There are 50,000 automobilists in California, and if all would vote for such a plank they alone could carry the measure." Charles C. Moore, president of the San Francisco Chamber of Commerce, and a more enthusiastic autoist, suggested that the State build object-lesson roads, showing to every county and district what a good road is like. Governor Gillett, who was delayed by a train wreck about fifty miles from Santa Cruz, and had to complete his trip in an automobile, spoke most urgently for the cause of good roads. It was he who suggested that bonds to the amount of \$18,000,000 be issued, which amount would be ample for the construction of about 3,000 miles of the finest macadam road that could be built, and the expense would hardly be felt.

## THE AUTOMOBILE CALENDAR.

## AMERICAN.

## Shows and Meetings.

- June 25-27.....—Detroit, Third Annual Summer Meeting of Society of Automobile Engineers.
- Dec. 31-Jan. 7.....—New York City, Grand Central Palace, Ninth Annual Automobile Show, conducted by the American Motor Car Manufacturers' Association, with Exhibits by the Importers' Automobile Salon, Inc., Alfred Reeves, general manager, 29 West 42d St.
- Jan. 16-23.....—New York City, Madison Square Garden, Ninth Annual National Show of the Association of Licensed Automobile Manufacturers. (Exact date to be announced.)
- February, 1909.—Chicago Coliseum and First Regiment Armory, Eighth Annual National Exhibition, National Association of Automobile Manufacturers. (Exact date to be announced.)

## Races, Hill-Climbs, Etc.

- June 24-27.....—New York and Philadelphia, Double-Head Endurance Run to Delaware Water Gap, under the auspices of the "Public Ledger" of Philadelphia.
- June 24-27.....—Chicago, 1,200-mile Reliability Run, Chicago Motor Club.
- June 27.....—Norristown, Pa., Skippack Hill Climb, Norristown Automobile Club.
- June 27.....—St. Louis, Second Annual Owners' Reliability Run, Automobile Club of St. Louis.
- June 30.....—Rockville, Conn., Hill Climb, Automobile Club of Rockville.
- July 4.....—Long Branch, N. J., Race Meet, Elkwood Park Automobile Association.
- July 4.....—Lowell, Mass., 250-mile Road Race, Lowell Automobile Club.
- July 4.....—Wildwood-by-the-Sea, N. J., Annual Speed Tournament, Motor Club of Wildwood.
- July 4.....—Indianapolis, Ind., Road Trials, Indianapolis Automobile Club.
- July 7-8.....—Buffalo, N. Y., National Convention of the American Automobile Association.
- July 9.....—Buffalo, N. Y., Start of the Fifth Annual A. A. A. Reliability Touring Contest.
- July 11-15.....—Milwaukee, Wis., Wisconsin Trophy Run, Milwaukee Automobile Club.
- July 15.....—St. Paul, Minn., Race Meet, Automobile Club of St. Paul, H. S. Johnson, Secretary.
- Aug. 14.....—Chicago, Third Annual Algonquin Hill Climb, Chicago Motor Club.
- Sept. 5-9.....—San Francisco-Los Angeles Reliability Run, Automobile Dealers' Association of San Francisco.
- Sept. 14.....—Chicago, Annual Economy Run, Chicago Motor Club.
- Oct. 24.....—Vanderbilt Cup Race, Long Island Course, auspices of Vanderbilt Cup Commission.
- Nov. 26.....—Savannah, Ga., Grand Prix Race, Savannah Automobile Club.

## FOREIGN.

## Shows.

- Oct. 11-18.....—Paris, International Congress and Public Exhibition on Roads and Road Making for Modern Locomotion, French Ministry of Public Works.
- December.....—Paris, Eleventh Annual Salon de l'Automobile, Grand Palais, Automobile Club of France.

## Race Meets, Hill-climbs, etc.

- July 6.....—Voiturette Grand Prix, Dieppe Circuit Automobile Club of France.
- July 7.....—Grand Prix of Automobile Club of France, Dieppe Circuit.
- July 13-17.....—Ostend, Belgium, International Race Week, Automobile Club of Ostend.
- Aug. 12.....—Ardennes Circuit Races and Coupe de Liedekerke, Automobile Club of Belgium.
- August.....—France, Coupe de la Presse, Automobile Club of France. (Exact date to be announced.)
- Aug. 29-30.....—France, Mont Ventoux Hill Climb, Vauclusien Automobile Club.
- Sept. 1-8.....—French Voiturette Contest, Auspices "L'Auto."
- Sept. 6.....—Bologne, Italy, Florio Cup Race, Automobile Club of Bologne.
- September.....—Paris, Vichy Aeroplane Competition, \$4,000 Prizes, Aero Club of France.
- Oct. 11.....—Berlin, Germany, Gordon Bennett Balloon Race, Aeronautical Club of Berlin.

## BOOKS OF AUTO INTEREST.

**Dunham's Auto Record and Expense Book.**—As its name indicates, this is intended to aid the autoist in keeping track of his trips, mileage, expenses and the like. The flyleaf is prepared for a brief digest of the biography of the car, such as name of its owner, name of the car, its factory number, license number, date of acquirement and the like. This is followed by an index page and then 42 pages are devoted to trip records. These are followed by pages tabulated for trip costs, a page for weekly mileages throughout the year, two pages for "miscellaneous troubles" and a like number for "tire troubles"; then follow spaced tables for expenses of various kinds, such as storage, batteries, carbide, oil, "ignition," gasoline, repairs and parts, sundries, cases and inner tubes, chauffeur, and a table to record the mileage obtained from each tire. Following there is a recapitulation showing the expense by months for the whole year. Its full title is "Dunham's Systematic Automobile Record and Expense Book," and it is published by the Dunham Press, Bridgeport, Conn.

**Guide Michelin, France.**—This is the ninth annual edition of what is looked upon as the handiest and most authoritative work on the roads of France. By the use of a large number of symbols, the character of a place, its hotel and garage accommodations and all other information necessary to the tourist is condensed into a remarkably small amount of space, and thus saves a great deal of trouble in making use of the Guide for reference. Each *Département* is represented by colored maps, and the latter are also given for the different towns and cities throughout the country. Customs information, the formalities to be gone through in registering and obtaining licenses, the speed laws and other information of a similar nature, all of which is very necessary to the foreigner, is given with much detail. Although the work is of convenient size for the pocket, it contains more than 600 pages, including 24 pages of colored maps of cities and some 60 maps of provinces or departments, beside a map of France entire, showing the divisions. There is also considerable information of a more or less technical nature included.

**"Motoring Abroad."**—Frank Presbrey, senior member of the Frank Presbrey Company, of New York City, is the latest to present the story of a trip in Europe by automobile, and his work, as named above, has just been issued from the press of the Outing Publishing Company. Credit is due to the author for getting away from the stereotyped method of rewriting Baedeker and school histories that has been indulged in to such an extent by his predecessors in the field, and as he neither believed in speeding nor following the beaten track, he succeeded in "seeing the country," and his book marks a departure from the usual method of telling how it was done. The pictures of the French roads, the numerous historical spots visited and the pleasant scenes are also better than many that have preceded them on a similar mission. This book is a volume of 294 pages, and is a beautiful typographical work.

**Die Kugellagerungen;** ihre Konstruktion unter ihre Anwendung für den Motorwagen-und Maschinenbau (Ball-bearings: their construction and application to the automobile and machine shop) is the title of a recent work by August Bauschlicher, just published by M. Krayn, Berlin. It is a book of 230 pages, well printed on good paper, but in paper binding, as is customary with German technical publications made to sell at a low price. It is being published at Marks 7.50, or about \$1.90, in paper, and about \$2.20 in regular binding. There are no less than 267 illustrations, supplemented by a great many tables and other data pertaining to the subject.

**A Treatise on Motor Vehicle Law.**—This is an excerpt from a work entitled "The Law of Motor Vehicles," which is a contribution to the Cyclopaedia of Law and Procedure, published by the American Law Book Company and written by Alfred W. Varian, of New York City. It is intended only for the practicing lawyer and is not a work for popular consumption.



# THE AUTOMOBILE

Vol. XVIII Thursday, June 25, 1908 No. 26

## THE CLASS JOURNAL COMPANY

Flatiron Building, Madison Square  
New York City

H. M. SWETLAND, President

### EDITORIAL DEPARTMENT

A. G. BATCHELDER, Managing Editor  
R. F. KELSEY, Associate Editor C. B. HAYWARD, Engineering Editor  
W. F. BRADLEY, Foreign Representative

### BUSINESS DEPARTMENT

A. B. SWETLAND, Business Manager  
LOUIS R. SMITH FRANK B. BARNETT  
W. I. RALPH, 1035 Old South Building, Boston, Mass.  
C. H. GURNETT, H. E. WESTERDALE, 1200 Michigan Ave., Chicago, Ill.

Cable Address - - - - - Autoland, New York  
Long Distance Telephone - - - - - 300 Gramercy, New York

### SUBSCRIPTION RATES:

United States and Mexico - - - - - One Year, \$3.00  
Other Countries in Postal Union, including Canada - - - - - One Year, 5.00  
To Subscribers—Do not send money by ordinary mail. Remit by Draft,  
Post-Office or Express Money Order, or Register your letter.

### FOREIGN SUBSCRIPTION AGENTS:

ENGLAND:—W. H. Smith & Sons, Ltd., 186 Strand, London, W. C., and all their  
railroad bookstalls and agencies throughout Great Britain; also at 14  
248 Rue de Rivoli.  
FRANCE:—L. Baudry de Saunier, offices of "Omnia," 20 Rue Lurist, Avenue de  
la Grande Armée, Paris.  
GERMANY:—A. Seydel Mohrenstrasse 9, Berlin.

Entered at New York, N. Y., as second-class matter.  
The Automobile is a consolidation of The Automobile (monthly) and the Motor  
Review (weekly), May, 1902, Dealer and Repairman (monthly), October, 1903  
and the Automobile Magazine (monthly), July, 1907.

Copies printed in 1905	- - - - -	730,000
" " in 1906	- - - - -	791,000
" " in 1907	- - - - -	888,000

## AN INDEPENDENT AUTO ENGINEERING BODY.

Although it naturally embodies much that lies within the scope of the mechanical engineer, as well as coming within the province of those who have been trained to steam and electricity, automobile engineering is in itself a decidedly distinctive branch of the art and as such it has shown that it stands apart. Early in the history of the development of the automobile, the need for mutual intercourse, support and aid that only an engineering organization can properly minister to, was keenly felt by those who were struggling to improve the power-driven vehicle, and it goes without saying that progress would have been even more rapid than has been the case, had there been any opportunity for cooperation. Manufacturers' associations were quick to feel this need and the result was the establishment of trade engineering organizations that have accomplished much—for their own benefit.

The real need, however, has been for an independent body, free from trade affiliations, and in the deliberations and investigations of which all automobile engineers could share. This has been met by the organization of the Society of Automobile Engineers, which holds its Third Annual Summer Meeting in Detroit this week. In selecting the latter city as the place of meeting, recognition has been paid to the fact that it has no rival for the honor of being the center of the American automobile industry, and the gathering, while merely one of

the regular occasions on which the automobile engineers meet, is of importance as illustrating the growth of the movement in support of an organization the chief object of which is to foster independent engineering investigation in the automobile field. It also provides an excellent opportunity for the technical fraternity of the industry to meet and become acquainted. At the outset, the idea was to form a body of designers who could benefit one another by mutual intercourse in the solution of the numerous problems that confronted them, but the movement has grown beyond that. There is a large body of trained men devoting their talents to the production of parts and accessories and in order to be thoroughly representative of the industry as a whole, they have been included so that the Society now includes in its membership, talent from every branch of automobile manufacture.

As a matter of fact, the accessory maker has frequently had a stronger influence on automobile design than has the man behind the draughtsman, and who has nominally posed as the creator of the car. This has been the case particularly where the large companies producing parts, such as motors, gear-sets, steering gears, rear-axle driving units and other components of equal importance are concerned, so that the engineers of such companies really fill the rôle of designer more fittingly than do those who select the parts and have them assembled.



## IMPORTANT ADVANCE IN AUTO REPAIRING.

Belonging in the category of things used mainly for pleasure, the automobile is something to which the ordinary ethics of business do not seem to apply—at least where the prices of repairs and replacement parts are concerned, and particularly the latter. But those dealers and makers who have set the figures for new parts so high that it would cost three times the list price of the car to build one from them, will find a serious setback to their activity in this direction in the recently developed process of autogenous welding. The details of the latter are fully described in this issue in the shape of a paper on the subject read before the Society of Automobile Engineers at its meeting at Detroit this week. A little consideration will reveal the endless possibilities that the process holds for automobile work.

The purchaser of a car with a one-piece four-cylinder casting need no longer dread the possibility of having to pay for an entire new set of cylinders, owing to some slight defect or accident, as repairs will often be possible without disturbing the engine. Nor need a hole or crack in an aluminum crankcase or gear-set housing any longer occasion its going to the scrap pile, as it may be made good in less time than is required to describe the operation. Broken crankshafts, whose only value hitherto has been to serve as models by which to produce their duplicates, may be made sound again at a fraction of the cost, and so it is with many other parts, the breaking of which has hitherto meant an expensive replacement. The possibilities of the new process are equally great where original construction is concerned, and manufacturing costs may be greatly reduced by the elimination of a very great percentage of the "wasters" that form such an important item, while great changes in construction methods which should do much to lower the cost of automobile building are also to be looked for from the new process in the near future.

## A. A. A. ENTRIES TARDY, BUT NOT BEHIND LAST YEAR

UP to last Monday twenty-three entries had been received for the A. A. A. reliability contest. They were made up of fourteen touring cars for the Glidden contest, seven runabouts for the Hower trophy and two official cars.

"The entries are as late in coming in as usual," said Chairman Hower, of the A. A. A. Touring Board, who was in New York on Monday. "Still we are only four entries behind the corresponding date last year, despite the fact that the fee has been doubled. Last year the morning before the closing of entries brought me forty nominations. The makers can and will not be hurried in this matter. I have every reason to expect the biggest and most glorious tour yet promoted by the A. A. A."

Mr. Hower says that while the tour is designed to be a severe test of the cars, it is not intended to be a killing task for the drivers, and that the fear of some that they will be required to drive as hard through excessive heat as ordinarily is unfounded, as due account will be taken of the weather and all allowances made for it in the schedule for each day. It was for just such contingencies that the power of altering the schedule was given to the chairman.

In order to facilitate the work of the thirty or forty representatives of the leading newspapers who accompany the tour, Chair-

man Hower has this year sent them the itinerary and requested the telegraph companies to make better arrangements than were to be had last year for handling the large volume of press copy filed at each overnight stopping place. He has received reply that this will be done. The official list of entries is as follows:

**For Glidden Trophy.**—No. 1, Charles Clifton, Great Arrow; No. 2, Charles Clifton, Great Arrow; No. 3, J. W. Maguire, Great Arrow; No. 4, R. M. Owen, Reo; No. 5, E. H. Parkhurst, Peerless; No. 6, E. H. Parkhurst, Peerless; No. 7, E. H. Parkhurst, Peerless; No. 8, R. M. Owen, Premier; No. 9, R. M. Owen, Premier; No. 11, Gus G. Buse, Thomas; No. 12, H. H. Franklin, Franklin; No. 13, John Wilkinson, Franklin; No. 14, G. H. Stillwell, Franklin.

**For Hower Trophy.**—No. 100, R. D. Garden, Great Arrow; No. 101, R. M. Owen, Reo; No. 102, W. H. Van Dervoort, Moline; No. 103, Charles Clifton, Great Arrow; No. 104, Henry Johnson, Premier; No. 105, John Breyfogle, Gearless; No. 106, F. A. Barton, Franklin.

**For Certificate.**—No. 10, Paul Gaeth, Gaeth.

**Non-contestants.**—No. 98, R. M. Owen, Premier, pilot car; No. 99, Charles Clifton, Great Arrow, chairman's car.

The latest entry to be named, and not included in the list, is that of Mrs. Joan Cuneo, or, more strictly, of her husband, Andrew Cuneo, whose 45-50-horsepower car will be driven by Mrs. Cuneo on the tour. This will be Mrs. Cuneo's third Glidden tour. Entries for the tour close July 3, with F. B. Hower, 760 Main street, Buffalo, N. Y.

### BOSTONIANS WILL WELCOME A. A. A. TOURISTS.

Boston, June 22.—Automobilists of this city are much pleased by the decision of Chairman Hower, of the A. A. A. Touring Board, to change the itinerary of the annual tour so that an over-Sunday stop will be made in this city. When the route and the day's run were announced the local enthusiasts were greatly disappointed because it was planned to have the tour pause here only over the night of July 17. It was felt that Boston, being the home of the donor of the principal trophy, and this city having always supported the tour, the over-Sunday stop should have been made here instead of at Poland Springs, in Maine. The protest of the local autoists was forwarded to Chairman Hower by Secretary James Fortescue, of the Bay State Automobile Association, and this morning came a reply stating that the plans had been changed so that the tour would stop here over Sunday, July 19, and then would continue on to Maine and New Hampshire. While the tourists are in Boston they will be entertained by the Bay State Association, and plans for the day are already under consideration. By that time the Bay Staters will be quartered in their new apartments in the Hotel Carlton, and will be in a better position to entertain a large party than ever before.

### A MODEL STATE TOUR TO BUFFALO THIS.

For touring to the big National Good Roads Convention at Buffalo, July 6, 7 and 8, the Pennsylvania Motor Federation has a plan that seems likely to commend itself to the organizations of other States in which tours are being formed. Chairman Godcharles, of the Pennsylvania Motor Federation touring board, is organizing its excursion in a way to include the whole State. There will be three sections to the tour, one starting from Pittsburg, to cover the western part of the State, one from the principal cities in the eastern part and the third section from the central part of the State.

This convention has been taken hold of in a way that has surprised its promoters, and its proportions are growing daily. Accommodations at Buffalo will be at a premium during the three days of the convention, and those going to it should secure their bookings ahead of time.

Those interested in the runs and other entertainments, apart from the practical work and the speechmaking, will find A. H. Knoll, chairman of the entertainment committee, at the Hotel Iroquois from now on. The hostelry mentioned will be the general headquarters of the American Automobile Association and all the committees of the convention.

## CLIFTON'S PIERCE NOW MAKING PRELIMINARY TOUR

"**SCHEDULE MAKER,**" a six-cylinder Pierce Great Arrow No. 1, for the Sixth Annual Tour of the American Automobile Association, and driven by Teddy Day, veteran of every great tour promoted by the A. A. A., left Buffalo June 18 for a trip over the route of the "mountain tour." This journey by Mr. Day will be made in company with John Williams, who will drive a runabout in the tour for Robert D. Garden, of the Harrolds Motor Car Company, of New York; Mr. Law, of the sales department of the George N. Pierce Company, and F. Ed. Spooner, the correspondent and photographer. The start was made at daylight, and each day's journey of the tour will be made in turn through Pennsylvania over the Alleghany, Blue Ridge and Pocono Mountains, up the Hudson, over the Adirondack and Catskill mountains, and through New England over the Berk-

shire mountains to Poland Springs, Me., and then returning over the White and Green Mountain ranges to Saratoga, where the tour will end, and then to Buffalo, to start out upon the tour itself within a few days. The car Mr. Day is driving will be No. 1, entry of Col. Charles Clifton, of the George N. Pierce Co.

All pathfinding tours made over the route of the annual event in the touring world are made at a time when the snows have just left the ground, and when the roads are at their worst. Frequent stops to inquire the way are made, and many stops for pictures bring delay. It is consequently practically impossible to determine the actual driving time, nor is it possible, except roughly, to determine the probable time which could be made. The objects of the present supplementary tour over the route are to determine the present condition of the roads, and also to determine the actual time which may be made in each day's run.

## EXPOSITION BUILDING FOR A. M. C. M. A. CHICAGO SHOW

**A**LFRED REEVES, general manager of the A. M. C. M. A., who has returned from a ten days' trip through the West, reports that plans for the association's proposed show in Chicago are practically settled.

The present plans call for the affair to be held in the Exposition building, at Forty-third and Halsted streets, which offers 148,000 square feet of floor space, or more than twice as much as can be obtained in any other building, either in Chicago or in New York. The show committee of the association will go to Chicago early in July to take up the final arrangements.

Almost without exception, the automobile factories of the West are working full time, turning out cars for this year and preparing for 1909. It is the universal opinion that 1909 should be a record year in motor car manufacture and sales.

"At Chicago," said Mr. Reeves, "the Holsman people continue to have a demand far in excess of the supply for their high-wheeled carriages, which, although primarily for use in the country, are being used in many of the big cities. The company has filled a certain field untouched by any other maker. The Holsman car has always captured clean scores in all reliability runs.

"At Kenosha, the Thomas B. Jeffery Company are working full time, turning out Rambler machines. With Mr. Jeffery I made a round of the factory, and the plant is certainly an extraordinary one, including, as it does, a half-mile track for testing cars.

"At Racine, the Pierce-Racine people announce that they will continue their successful model of the present year. The Mitchell Motor Car Company are in an enviable position with their four-cylinder runabout, which, in the opinion of many, is extraordinary value for \$1,000. The plant is working right up to its limit turning out cars, and Messrs. Gilson and Bates told me plans were under way for increased facilities for 1909.

"W. H. Van Dervoort, president of the Moline Automobile Company, at East Moline, Ill., showed me through one of the best equipped factories in the West, and outlined their plans for

1909, which will include some sensational cars at sensational prices. They have entered a Moline for the Hower trophy in the Glidden tour, and the car selected is now being put through a course of hard trials. It will be piloted by Neil Van Dervoort. The Moline Automobile Club is being formed by automobilists in that city, and W. H. VanDervoort is slated for the presidency.

"At the Midland factory, Mr. Walton showed me the progress that had been made in getting out this year's product, and indicated some promising plans for 1909. One of the surprises on my trip was the well-equipped factory of the Kisselkar Company at Hartford, Wis. They will have two cars in the Glidden tour. I was shown the motor of the new six-cylinder, 60-horsepower Kisselkar that will sell at \$3,000. Their four-cylinder car, which is handled in Chicago by Webb Jay, has performed well in all contests, and has had an excellent sale.

"I attended the first day of the Republican convention at Chicago, and it is surprising how many men in automobile manufacture are interested in politics. Many of them were there as delegates. Among others I met were R. E. Olds, Benjamin Briscoe, J. D. Maxwell, Job E. Hedges and Capt. Walter E. Edge of the Atlantic City Automobile Club."

### ALFRED REEVES UNDERGOES OPERATION.

Alfred Reeves, general manager of the American Motor Car Manufacturers' Association, was successfully operated upon for appendicitis at St. John's Hospital, at Yonkers, N. Y., on Monday, and is now practically out of danger, though he will probably be confined to the hospital for a fortnight yet. During his recent Western trip, Mr. Reeves complained of pains in the region of the appendix, and on his return home last week consulted his family physician, who advised an operation. He accepted the suggestion, and went to the hospital on Sunday. Mr. Reeves had contemplated another Western trip, which would take him as far West as the Pacific coast, but this journey will now have to be postponed for some time.

## SOMETHING BEHIND BRIARCLIFF COMMITTEE MEETING?

**T**HERE was a meeting of the contestants in the Briarcliff race at the Automobile Club of America last Thursday evening to discuss and organize for next year's contest. It seems the conditions of the trophy provide that those contestants in the 1908 race who shall consent in writing to serve, shall constitute the "Executive and Rules Committee."

The official report of the meeting says that 14 contestants were present without giving any names. Those known to have been in actual attendance, however, embrace C. F. Wyckoff, of Wyckoff, Church & Partridge, agents for the Stearns; S. B. Bowman, of the Bowman Automobile Company, agent for the Clement-Bayard and Apperson; H. A. Lozier, of the Lozier Motor Company; Walter C. Allen, of the Allen-Kingston and De Dietrich agency; Paul La Croix, of the Renault agency; Mr. Koch, of the Isotta Import Company, and Percy Owen, of the Bianchi agency.

Robert Lee Morrell, chairman of the 1908 committee, presided, and T. Francis Moore occupied the secretary's seat until their successors were appointed in the persons of C. F. Wyckoff, as chairman, and Sidney B. Bowman, as secretary, both announced to be but temporary appointments. Messrs. Morrell and Moore were then asked to withdraw as the gentlemen present desired to hold a closed session. It has been surmised, and it is very generally believed, that the discussion had to do with a project in contemplation by New York dealers in the direction of an inde-

pendent stand in the matter of any sanction or disqualification that may be granted or made by either the American Automobile Association or the Automobile Club of America. Color is lent to this assumption from the fact that following the meeting Tom Moore was told that his Elkwood Park meet had been approved.

The official report given out, however, gave no inkling of any such discussion or action. It stated in part:

"In view of the fact that the 1909 committee is empowered by majority vote to add to its number if it so desires, it was decided not to elect permanent 1909 officers at this time. It was pointed out that it would be advisable to effect a temporary organization for the present, so as to allow any members who may be later added to the committee, the privilege of a voice in the selection of permanent officers for 1909.

"Later meetings will be held to plan the many details, and to settle on the question of a suitable course for the 1909 race.

"By getting the preparations under way early, it is hoped that the large volume of work will be distributed, and that the duties of those who will have the actual handling of the details will be less arduous than is frequently the case where much of the real labor is crowded into a few weeks' time."

Incidentally it is reported that Robert Lee Morrell apologized to the committee for the use under a misapprehension of the wording of the Deed of Gift of the Briarcliff race in the regular list of the Automobile Club of America's proposed promotions.



The Sign That Greets the Driver in Middleboro, Mass.

### HOW "SQUARE DEAL" WORKS IN BAY STATE.

MIDDLEBORO, MASS., June 8.—The question that has become a perplexing problem in many of the towns and cities of this State regarding the regulation of the automobile speeding through the towns has been practically solved by the local automobile club and it is daily receiving commendatory letters from all parts of the country.

For the past three years the selectmen have been troubled as to how they should proceed against the automobile speeders who were endangering life and property by their reckless driving through the town. Traps were resorted to and several arrests were made, but in some cases the innocent driver suffered, for he meant to drive carefully but was a little over the limit.

The stringent enforcement of the law meant a black eye to the business interests of the town, for drivers and owners would not stop here to purchase anything on their way to the beaches, and the merchants began to kick. It was then that the local automobile club came to the rescue and waited on the town selectmen. They asked that they have the privilege to make a try to regulate the speeding. It was rather a large question to ask to take the law out of the proper officials' hands, but, nevertheless, the request has been granted and the club immediately set to work.

Last year the club passed out cards stating that if the drivers would go slow through the town there would be no trouble in court proceedings. It proved successful, and this year the club has been given the same permission to regulate the speeding of machines through the thickly settled portion of the town. Banners have been stretched across all inroads to the town asking drivers not to exceed 12 miles per hour, and that the club will give them a square deal if they will give the club one. These signs are painted on canvas and stretched across the streets in such a manner that the drivers cannot help but see them. They are doing lots of good and there are very few cases of speeding now. There are, of course, a few "smart" drivers who ignore the signs, and speed at some places in the road, but members of the club know them, and if they continue they will be haled into court.

### AMATEURS TO BE FEATURED AT ELKWOOD.

"The Long Branch Special," a ten-mile race for amateur drivers, under A. A. A. rules, is to be made a prominent feature of the Fourth of July meet, at Elkwood Park. This event is arousing much interest among the millionaire sportsmen who are promoting the meet. Among those who have already entered are Robert Guggenheim, Oscar Lewisohn and Alfred Seligman. Harry Levy has challenged all comers to go against his sprint record-holding Hotchkiss at from one to five miles, for a purse to be put up by the Messrs. Lewisohn. This race promises to eclipse all others in point of interest.

### ALL READY FOR THE WATER GAP RUN.

PHILADELPHIA, June 22.—There will be a great outpouring of automobilists Poconowards next Wednesday morning, when the first day of the carnival of the Monroe County Automobile Association begins with a reliability run to Stroudsburg. The start from this city will be made from the White garage. A double schedule has been arranged—a 20-mile-an-hour limit for Classes A and B (touring cars and roadsters) and a 15-mile rate for Class C (small runabouts). MacDonald and Campbell have hung up a cup in the big class, similar trophies to be awarded to the winners in the other classes.

There was much uncertainty among the local entrants for the reliability run and the hill-climbs at the Delaware Water Gap and Canadensis as to the possibility of competing there and at Norristown on Saturday next, where many of them are also entered, but the Monroe county people settled that question by giving assurances that they would rearrange their program so as to insure its completion by midday Friday, thus giving everybody ample time to run down to Norristown for the big hill-climb at Skippack.

The list of entries for the latter event, by the way, has grown both in numbers and character of entrants until it has assumed the proportions of a national affair. Up to date no less than sixty-one entries, representing thirty-three separate manufacturers, have been received, and, as the road is in excellent shape, good weather is all that is needed to make the affair a success. With "Willie" Haupt's Chadwick, the Vanderbilt Pennsylvania, the big Stevens-Duryea, the Matheson, the Stearns, the Stanley steamer, and several other specially prepared cars out for the honors, the free-for-all, will be especially hard fought.

There will be nine events in all. Six gasoline classes—\$850 and under, \$851 to \$1,250, \$1,251 to \$2,000; 2,001 to \$3,000, \$3,001 to \$4,000, and \$4,001 and over—are programed. There will be besides a free-for-all for steamers, a free-for-all for gasolines, and a free-for-all electrics, the latter with eight entries.

Skippack Hill, as that portion of the Reading pike which shoots straight up from the valley of Skippack Creek is called, is 6,270 feet long, with a total rise of 352 feet and grade which at its steepest is close to 10 per cent.

### BUFFALO CLAIMS ORPHANS' DAY RECORD.

BUFFALO, N. Y., June 18.—In its fourth annual celebration of Orphans' Day yesterday, the Automobile Club of Buffalo carried 1,577 children in 227 cars. It is believed that both in cars and children this is a record for the biggest club in the American Automobile Association.

[New York's Automobile Row Orphans' Day committee this year had 150 cars and trucks in line with the total number of children carried estimated at 1,500. Cars and trucks were packed to their utmost capacity, but no official count was made. A Packard truck, for instance, bore 70 orphans.—Ed.]



Buffalo's Orphans Coming Up Shady Delaware Avenue.



## JUNETIME HAPPENINGS AMONG THE CLUBS

### ALBANY CLUB START ON ANNUAL TOUR.

ALBANY, N. Y., June 20.—Carl Robinson, acting as official starter, had only six cars to send off, instead of thirty expected, when the annual endurance run of the Albany Automobile Club began this morning, at 6 o'clock. Those who stood by the annual event were: Matthew Van Alstyne, M. L. Ryder (two cars), J. B. Taylor, Fletcher Battershall, and Howard Martin. The run will last six days, and the route to be covered is from Albany to Greenfield, Mass.; to Providence, R. I., to New London, Conn., to Waterbury, Conn., to Albany. The car returning with the seal on the bonnet intact wins the prize, a silver cup offered by Archibald McClure. Wives and other feminine members of the families of the autoists accompanied them. It is to be a real endurance run, with speeding tabooed. While most of the members of the Albany club found it inconvenient to get away at the last moment, the club has a good record for the past, and this month it put over 100 automobiles in line and gave the orphans of all the asylums the time of their lives—an all-day tour about the city and suburbs, with refreshments served at a road-house several miles out.

### THE CRACKS TO BE AT ST. PAUL'S MEET.

ST. PAUL, MINN., June 23.—Preparations for the great Shriner's meet on July 15 at the Hamline track are being pushed with vigor. H. S. Johnson, chairman of the racing board of the Automobile Club of St. Paul, reports gratifying progress in his negotiations toward securing the attendance of the crack cars and drivers of the country. He is confident that terms can be made with Barney Oldfield to insure his meeting Walter Christie. It is hoped and expected that Harry Levey will enter the Hotchkiss, which scored world's road records for the mile and two miles at the Jamaica, L. I., time trials, and that the entry of Maurice Bermin and his Renault will be secured. Fred J. Wagner, the official A. A. A. starter, who has great influence with all the racing cracks, is at work securing the signatures of the Eastern flyers.

A tri-city event is being organized, in which it is assured that C. A. Coey, of Chicago, will be a contender.

New track records are practically assured, since the Hamline course has been widened ten feet since Christie made his 52 seconds record mile on this circuit last autumn.

### AKRON AUTO CLUB ELECTS NEW OFFICERS.

AKRON, O., June 22.—Officers were elected by the directors of the Akron Automobile Club on Friday evening last, as follows: President, Fred Work; vice-president, A. B. Smith; secretary, Andrew Auble; treasurer, E. H. Roth. The officers were given power to go ahead to push the construction of the Brecksville road, with a view of completing an improved highway from Akron to Cleveland. A consideration of the list of officers will convince anyone that the Akron Automobile Club will no longer be a dead proposition. Work, Smith and Auble are three of the most enthusiastic and energetic automobilists in Northern Ohio, who will leave nothing undone to boom things.

### BREAK A SEAL AND YOU'RE OUT OF RUN.

WILMINGTON, DEL., June 15.—The Delaware Automobile Association is making arrangements for a sealed bonnet run on June 27, from Wilmington to Valley Forge, Pa., via Philadelphia, and return. If a seal be broken the contestant must drop out. Thus only those with perfect scores will finish. There will be classes according to the value of the machines and three silver cups will be offered as prizes. Entries will close with Charles G. Guyer, 826 Market street, on June 23. The entrance fee for members will be \$3; for non-members, \$5.

### WOMEN'S MEMBERSHIP FOR THE L. I. A. C.

BROOKLYN, N. Y., June 24.—In order that women may enjoy the full privileges of the Long Island Automobile Club's country house, an amendment to the constitution is to be proposed, giving to them such membership as will entitle them to the use of the country house and the garage operated by the club and also to the right to display the club pennant on their cars.

Prizes won in the recent time trials at Hillside avenue will be presented at the clubhouse, 360-366 Cumberland street, Brooklyn, on the evening of Tuesday, June 30. The names of the various winners have been etched on the trophies, a longer and more expensive process than the usual engraving. Refreshments will be served and through the courtesy of J. Stuart Blackton, of the American Vitagraph Company, moving pictures of the time trials and the Long Island Motor Parkway inaugural will be shown for the first time. The presentation ceremonies will begin at 8:30 P.M.

The club has erected danger signs at the crossing of Betts and Thomson avenues, Woodside, L. I. At this point both thoroughfares are on a steep hill and one street is obscured from the other by a high hedge. This spot has been the scene of many serious accidents between different kinds of vehicles, as it is often congested with long lines of coaches and carriages going to the different cemeteries in the vicinity.

The club warns autoists of an especially vicious speed trap at Hicksville, L. I., which is unusually active on Sundays.

### BAY STATE ASSOCIATION'S ANNUAL OUTING.

BOSTON, June 20.—The Bay State Automobile Association is to hold a club run and outing July 4-5 to the Hotel Wentworth, in New Castle, N. H., and preliminary announcement of plans has been made by the touring committee, consisting of J. C. Kerrison, H. G. Kemp, Ernest A. Gilmore and V. A. Charles. Those who desire to avoid the noise of the night before the Fourth may make the trip to New Castle on Friday evening, but the larger number of club members will drive down Saturday morning. The route to be followed will be over the beautiful shore roads leading through Lynn, Salem and Newburyport, the same route that is to be followed by the Glidden tour later in the month. Saturday at New Castle arrangements have been made for outdoor amusements, baseball, tennis, bathing and the like, and in the evening there will be a dance. Sunday the motorists will spend as they see fit, most of them probably taking the afternoon for the drive home. Special rates have been secured, and all are anticipating a pleasant outing.

### WOMEN TO DRIVE IN ST. LOUIS TEST RUN.

ST. LOUIS, June 23.—Indications point to a great success for the second annual owners' reliability run of the Automobile Club of St. Louis. It will take place on June 27, over a course of 110 miles, the prize being the James Hagerman, Jr., trophy.

Included among the entrants is Miss Ida Britton, a sister of Roy F. Britton, a governor of the club, who will drive a 45-50 horsepower Pope-Toledo. It is more than whispered that another St. Louis society girl will also be among the contenders.

The regulations do not permit racing, and bar all automobile manufacturers, agents, dealers and every one who has in any way received compensation for driving a car. The course, which has many hard hills, will be divided into six controls.

### ANOTHER NEW YORK HILL CLIMB ON JULY 8.

Several gentlemen have organized the Riverside Motor Club, and will, as such, promote a hill climb on July 8, on Depot Lane Hill, starting at the Boulevard Lafayette and ending on Fort Washington Heights, near the Arrow Head Inn. There will be eight events.

## LATEST FLIGHTS OF THE AEROPLANISTS

PARIS, June 17.—All aeronauts who have given public demonstrations have been content to remain as near the ground as possible in order to be prepared for any possible failure of the motor to fulfill its functions. Robert Esnault-Pelterie, the twenty-six-year-old inventor of the seven-cylinder R. E. P. motor, has created a new record by flying to a height of about 120 feet. The operation took place at Buc, a deserted plateau on the suburbs of Versailles. Before about fifty spectators Esnault-Pelterie brought out his monoplane flying machine and made half a dozen flights of about half a mile each at a height varying from 2 to 18 feet from the ground.

The motor running satisfactorily and the aeronaut having found his bearings by the preliminary canter, preparations were made for a longer flight. From the extreme end of the field the machine ran over the ground for a few seconds, then mounted into the air at the speed of 50 miles an hour. From a height of six feet the apparatus rose higher and higher until it was a white speck in the sky, the maximum height being certainly not less than 120 feet from the ground. In his rapid flight Esnault-Pelterie had passed over the apple trees on the edge of the ground and got beyond the limits of his training field. To the spectators he appeared to be hovering over the village of Toussu-le-Noble. Suddenly the entire apparatus was seen to descend to earth at a rapid rate. It was not sufficiently fast to be called a fall, yet too fast to be safe for the pilot.

When the spectators reached the spot Esnault-Pelterie was lying in a field of clover with his machine beside him. The pilot had been considerably shaken but had no broken bones, and a little damage had been done to the aeroplane. According to the explanation the aeronaut gave of the accident, the fall was entirely due to a too rapid manipulation of the rudders. Owing

to the rapid rate of travel, certainly not less than 50 miles an hour, the aeroplane arrived at the limit of the ground much quicker than had been expected by the pilot. Fearing that if he continued any further he would have to come down in the middle of the village, Esnault-Pelterie operated his rudders at once and descended faster than was advisable for his own safety and that of his machine. Fortunately there was no serious damage, and while the pilot is passing a few days' quiet at home he will have the satisfaction of knowing that he holds the record for height and speed. The distance in a straight line from the starting point to the descent was exactly one mile; this, of course, does not take into consideration the upward and downward curve.

Esnault-Pelterie's machine, the second one he has produced, is a monoplane having a total bearing surface of 226 square feet, weighing 770 pounds and driven by a seven-cylinder R. E. P. motor, the separate weight of which is but 80 pounds. The bearing surfaces have been so well studied that for an area of 10 square feet a weight of 45 pounds can be borne. A special type of four-bladed propeller is employed, and the normal speed of the apparatus when in the air is 50 to 55 miles an hour.

### DELAGRANGE FLIES 11 MILES IN 16 MINUTES.

MILAN, ITALY, June 22.—Leon Delagrange, the French aeroplane pilot, this evening surpassed all previous records by flying for 16 minutes and 30 seconds. During that period his machine was from 10 to 18 feet above ground. He made nine rounds of a measured course at the velocity of 38 miles per hour, covering about 18 kilometers, or a trifle over 11 miles.

A specially designed medal is to be given to M. Delagrange, commemorating the occasion.

### HUNTING AND TRAPPING IN AN AUTO.

Four years of hunting and trapping in the Rocky Mountains in a Rambler runabout has been the unusual experience of M. C. Ramsey, Grand Junction, Col., an enthusiastic autoist. In all seasons of the year and under all road conditions, Ramsey has made long automobile excursions into the mountains after game. The car he drives is a 1904 one-cylinder Rambler and Ramsey claims to have covered several thousand miles with practically no expense for repairs.

Last February he made a 100-mile run up the western slope, and on this occasion he returned to Grand Junction with 78 rabbits as a result of three hours' shooting. The photograph shows him and his car at the highest point in the Rockies ever reached by an automobile.



How a Rambler Runabout Mounted the Rockies.

### MILWAUKEE-CHICAGO ROUTE HAS NEW GARAGE

RACINE, WIS., June 20.—The accompanying photograph shows the fine new building recently erected for the Miller Motor Company, of this city, as a garage, and which will supply a much-needed supply station for tourists along the Lake Shore route between Chicago and Milwaukee, this being a much-traveled road. The building measures 45 feet in width and is 120 feet deep; it is of concrete block construction with a concrete floor, and is thoroughly fireproof. Its capacity is 40 cars, ranged along the sides of the building, so that any one may be taken out without disturbing any of the others. One of the features of the new establishment is its finely equipped repair shop, which is fitted with machine tools for all kinds of repairs. The cars shown in front of it are Pierce-Racines, which are built in this city.



New and Modern Garage Just Opened at Racine.

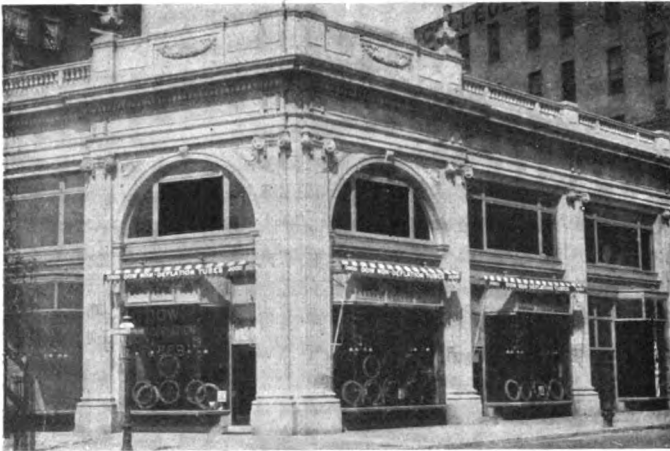

Where the Dow Tire Company is Now Housed.

### NEW HOME OF THE DOW TIRE COMPANY.

Judging from the developments of the past year or so in this direction, New York's automobile "row" bids fair to be an assemblage of offices and salesrooms the equal of which will seldom be found in any quarter of any city, no matter how exclusive. Both the manufacturers of automobiles and the makers of accessories have located with a view to the permanency of their establishments, and the fittings and equipment of the latter are of a nature which shows that their owners have spared no expense to make them appropriate homes for the business to be carried on therein. One of the latest concerns to locate along the "row" is the Dow Tire Company, which recently moved from its former quarters in Forty-second street, to what its occupants term "the handsomest little office building in New York City," the two-story architectural gem built by the Rhinelander estate at the corner of Broadway and Sixty-eighth street.

The interior fittings are of dull finished oak throughout, and follow the general architectural lines of the building itself, so that the whole is in perfect harmony. The new quarters house a finely equipped display and salesroom, and the offices of the company, which are fitted up in a manner to set an appropriate standard for the metropolitan agencies of the tire companies, although some of the latter already have salesrooms of which their owners may well be proud. In the corner of the lower photograph, illustrating a portion of the Dow salesrooms, is shown the special machine designed to demonstrate the wonderful puncture-proof properties of the Dow nondeflation tube. This has been exhibited at all the automobile shows, and as the tire can be subjected to any load and run at any speed, after the nails or other sharp objects have been driven into it, the self-healing properties of the Dow tube are strikingly proven.

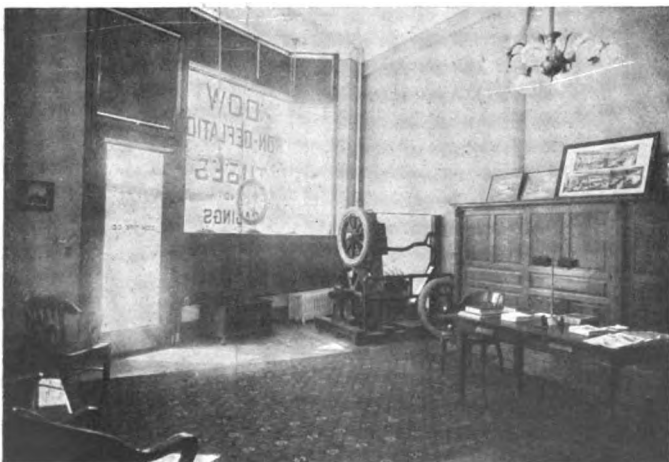

View of a Corner of the Salesrooms, Main Floor.

### AUTOMOBILES AID MIMIC WARFARE.

CAMP PINE, N. Y., June 22.—One of the most important problems which the War Department is working out at the National and State encampment at Camp Pine, near Watertown, is the adaptability of the automobile for military purposes. The machines chosen for this test were two 30-horsepower Studebakers of the same model which so successfully carried General Grant's message from New York to Fort Leavenworth, Kas., last winter. One of the machines was shipped direct to Camp Pine, the other was given a preliminary test over the road. This car made the trip from New York to the camp, a distance of 354 miles, in 15 hours and 18 minutes. In the car were Lieut.-Colonel E. F. Glenn, chief umpire; Captain W. T. Johnson, assistant umpire, and Major Woodruff, chief military officer. "I was very much pleased with the trip," said Colonel Glenn, upon his arrival at the camp. "Barring one or two punctures, the car behaved perfectly and I am thoroughly convinced that it is only a question of time when automobiles will be used in all military maneuvers."

The real test of the machines began, however, upon their arrival at the camp. One of the cars is being used by General Grant and the other by his staff officers. The 144 square miles included in camp comprise every sort of rough country, full of stumps and ruts, either roads with hub-deep sand or no roads at all and



General Grant in Studebaker Car Conducting Maneuvers.

rough, steep hills. Both machines have been constantly in service since their arrival and all the staff officers are wondering how they ever managed to get along before without an automobile.

No one in the camp is better pleased with the showing made by the automobiles under test than General Grant. He uses his machine a great deal and has noted the performance of both cars very closely. He said to-day: "I should not have believed that it was possible for an automobile to go the places these two Studebaker machines have gone if I had not witnessed it myself. During the week they have been here they have been put to the most severe test and haven't been out of commission for a minute. They are especially valuable in plotting out problems where it is necessary to carry maps and other paraphernalia not easily conveyed on horseback. I believe that not only is the automobile of great value in military work but, more than that, it is a necessity. I am greatly pleased with the excellent showing made by the two machines being tested."

### WHITE SQUADRON AT OYSTER BAY AGAIN.

With the return of President Roosevelt to Oyster Bay, the two government White steamers have resumed service. The two cars are now operated on the same schedule as last year, making the first trip to Sagamore Hill at 7 o'clock in the morning and the last trip after midnight. There is but little time during the day when the cars are not engaged on some official mission. Last season the two cars went through the four-months' season with a record of never having missed a trip and never having been late.

## BRIEF ITEMS OF NEWS AND TRADE MISCELLANY

The MacDuffee Automobile Company, Chicago agents for the Stoddard-Dayton cars, have found it necessary to rent another floor in order to take care of their increasing business. It measures 30 by 161 feet and will be used altogether as an equipment room.

Following the general practice of those who are building cars for the Vanderbilt Cup race, to be held on Long Island in October, the Acme Motor Car Company, of Reading, Pa., will equip their six-cylinder entry, known as the Acme Sextuplet, with Truffault-Hartford shock absorbers.

The Moon Motor Car Company, of St. Louis, Mo., has been adding to its plant considerably during the past month. Owing to the heavy demand for Moon cars, it was found necessary to make considerable increase in the capacity of the machine shop. Additions have been made principally in the high grade grinding machines.

The Rubberized Leather Company, Gloversville, N. Y., has just completed moving into its new mill recently purchased of C. O. Bartlet on North Bleeker street, which gives additional floor space of 40,000 square feet over the former mill on Forest street. This gives the company one of the most complete and up-to-date tanneries in northern New York.

A special telegram to R. M. Owen & Company, New York, from their Chicago representatives, the Walden W. Shaw Company, reads as follows: "Eighteen consecutive centuries, aggregating 2,000 miles, just completed by Premier '30' without single mishap to car or tires. Car now going over different circuits in and out of Chicago, including Elgin and Aurora. Running as beautifully as when first started. Local autoists enthusiastic."

The Palmer & Singer Manufacturing Company announce that the entire output for 1908 has been sold and that already 16 applications are in for 1909 Simplex models. This is an indication of the power and scope of the sales organization maintained by this big concern. Within 40 days after the announcement that the Palmer & Singer Manufacturing Company had purchased the output of the Simplex factory, they had sold more Simplex cars than the entire 1907 output of the factory.

The Baker Electric roadster Model "M" was the fastest electric in the hill-climbing contest held June 13 on Porter hill, near Cleveland, O., its time, 1:00 3-5, was beaten by only five of the many high-powered gasoline cars entered. The course was one-half mile in length on a grade averaging over 16 per cent. with country road conditions. The great power developed and endurance shown fully demonstrates Baker excellence, durability and mechanical construction, and is worthy of more than passing notice.

The appearance of the Hol-Tan cars is expected to be scheduled for next week. It is believed that the new line will show a number of minor refinements in addition to the radical good points of construction which will cause them to appeal at once to the taste of the public. Coincident with the beginning of deliveries of these cars, the Hol-Tan Company will inaugurate a campaign of participation in prominent events with an idea of giving all interested a chance to see how good the car is under competitive conditions.

Midland cars, it is announced, will be seen in many of the hill-climbs and races in the East during the present season. The Allenhurst Garage, of which P. L. Toplitz is manager, has the metropolitan agency for the Midland and it is through this agency that the exploiting of Midlands will be undertaken. It is announced that entry of a car in the Wildwood, N. J., events on July 4 had been made and the car will also be seen in the Monroe county festival events on June 25 to 27. Deacon Holmes, the assistant manager of the Allenhurst Garage, will pilot the car in all its public appearances.

In the recent announcements of the Goldberg Motor Car Devices Manufacturing Company, 1253-1255 Michigan avenue, Chicago, which have been appearing in THE AUTOMOBILE, mention has been inadvertently omitted of the New York offices of the company. These are located in the recently completed Thoroughfare building, on Fifty-eighth street, extending from Eighth avenue to Broadway, and are in charge of C. S. Gibson, who was formerly with the Packard company. Under the management of Mr. Gibson, the Stromberg carbureter, as it is now known, is rapidly obtaining a successful introduction here in the East.

The Irish Automobile Club Reliability trials include an endurance run from Dublin to Killarney to Limerick to Belfast and back to Dublin, a total distance of 345 miles, beside two hill-climbs and a sand test, the winners to make the best total showing. In open Class A for small two-seated cars, the 15-horsepower Ford was the only one to make a non-stop. As regards speed in this class, the Ford made the fastest time in both the hill-climbs and the speed trial on Rossbeigh sands. The 15-horsepower Ford was also successful in Class B on the Hollywood (Slieve Corragh) hill and on Rossbeigh sands. The gold medal for all around performance was won by the Ford 15-18-horsepower, this make thereby repeating its performance of last year.

Entries covering three Franklin touring cars and one runabout have just been received by Chairman Hower, of the Fifth Annual Reliability Contest of the A. A. A., entries being made by the Automobile Club of Syracuse. This is the first time in the history of the Glidden tour that the Franklin car has been represented, the reason heretofore given being that the tour, while no doubt allowing contestants an opportunity to demonstrate some of the good points of their machines, did not, to any great extent, prevent the less able cars from qualifying in a manner which would cause it to appear that they were equal to their more worthy competitors; in short, it has up to this time been looked upon as more of a tour than a reliability contest; this, however, is not true of the coming event which, on account of the penalization system, is more severe and proves better the points claimed for the entrant's car. The fact that the Franklin is an air-cooled car, and the Syracuse team will probably be the only one consisting entirely of air-cooled cars, gives somewhat of a distinction to this particular entry.

### NEW AGENCIES ESTABLISHED.

The Whitten-Gilmore Company, which has handled the Thomas line in Boston and

Eastern Massachusetts this season, has taken on in addition to the Thomas line the Chalmers-Detroit cars.

The Standard Roller Bearing Company, of Philadelphia, announces further expansion of its sales organization by the opening of a branch office at 327 Jefferson avenue, Detroit, in charge of Ernest L. Smith, recently appointed Western representative for the company.

The Bosch Magneto Company announces the opening of a new branch office at No. 1253 Michigan avenue, Chicago. This office will cover territory lying in Illinois, Michigan, Wisconsin, Indiana, and the States south and west of Chicago. A technical department and machine shop is also installed.

The unique distinction of being the loftiest motor vehicle agency in the world is claimed by the Couple-Gear Company, of New York, whose offices are five hundred feet above the ground, on the thirtieth floor of the Singer tower on Broadway. This company has taken the agency for the metropolitan district for the Couple-Gear electric and gasoline-electric trucks and delivery wagons.

One of the latest comers on Broadway is the Manufacturers' Distributing Company, who are located at the corner of Sixty-third street and Broadway. The members of the concern are John Paine, late of the Warner Instrument Company, and D. E. Sullivan. The new firm are New York agents for the J. H. Sager Company, of Rochester, N. Y., and are carrying a full line of Sager's equalizing springs, tire chains and protection bumper.

### PERSONAL TRADE MENTION.

F. W. Lawrence, formerly connected with the Federal Manufacturing Company, has recently joined the sales organization of the Standard Roller Bearing Company of Philadelphia.

Charles E. Duerr has taken the New York agency for the Moon. Mr. Duerr is a pioneer in the metropolitan automobile trade. He was last associated with the selling of the Royal Tourist. Among the makes with which Mr. Duerr has been identified as a New York agent were the Searchmont, Ford, Mitchell and Queen.

Oscar E. Boles, assistant sales manager of the Lozier Motor Company, was found dead in his bed at his lodging house in New York last week. Mr. Boles was for seven years manager of the Lozier European branches at London and Paris. In his younger days Mr. Boles was a cycle man of prominence on the Pacific Coast and manager of different bicycle agencies at Denver.

T. D. Grimke Drayton, chairman of the board of directors of the parent company in England of the Spare Motor Wheel of America, Ltd., is now in this country and is much pleased with the progress made by the American branch since his last visit here. The company has recently closed agency contracts with ex-Mayor Sherburn Becker, of Milwaukee, who acts as distributor of the Stepney spare wheel in the State of Wisconsin, and W. B. Drown, formerly of the Auto Parts Company, of Cleveland, O., who will act as representative in that city.



## INFORMATION FOR AUTO USERS

**Rands Rumble Tops.**—Ever since the advent of the type of car with a rumble seat in the rear, it has been a question, what type of top such a car should carry. Where it was intended that only the chauffeur should occupy the seat in the rear, the problem was solved by not covering the rumble seat at all, but as the double rumble is usually intended to carry passengers, the problem was still open. The Rands Manufacturing Company, Detroit, Mich., who make a specialty of automobile tops of every kind, have taken up the problem and solved it in a manner that will please the particular autoist. This new Rands top is so made that the bow crossing the entrance to the car has been entirely done away with, so that when the top is folded it is very compact and projects but little behind the rear seat. The desired effect for such a car has been accomplished in this manner, while still keeping the top light, yet very strong.

**Star Speedometer.**—This is a newcomer to the field of speed and distance-recording instruments on the automobile and is the product of the Star Speedometer Company, Danville, Pa. It is of the familiar centrifugal type so largely employed for this purpose, and is very well made throughout, so that the makers feel safe in guaranteeing it unconditionally to be accurate under all road conditions. It is made in several styles with 60 and 100-mile scales, one of its exclusive features being a "catch the speed" device. By pressing a knob on the front of the case the indicating pointer can be stopped at the exact speed the car was running at the time the knob was pressed. The odometer used is an exclusive product with this concern and is a specially constructed locked wheel device. Right angled connections at the instrument are used, thus bringing the driving shaft in a straight line from the wheel to the speedometer.



STAR SPEEDOMETER.

**Reliable Self-Starter.**—That there is a widespread demand for a self-starting device on the automobile is a matter for common knowledge. Many attempts have been made to meet it in the past, but with few exceptions the devices presented have failed to combine the qualifications of simplicity and compactness with ease of operation so that at the present moment there is nothing of this nature on the market that is in general use. The Beamer Manufacturing Company, Detroit, Mich., appear to have struck nearer the solution of the problem than has been the case heretofore. The device is termed the "Reliable" self-starter and a review of its specifications shows that its inventor has had in mind the essentials above mentioned. It consists of a nest of multiple cylinders and plungers combining a gasifier and pump that can be located on the footboard or under the hood, with the operating handle within easy reach of the driver. By a very simple method, a small amount of gasoline is mixed with air, and vaporized, and the

resulting fuel gas is forced through copper tubing direct to each cylinder, a few strokes of the handle being sufficient to charge the motor so that it will start promptly and positively upon the ignition circuit being closed. The device complete can be installed in half an hour by an ordinary mechanic and no changes whatever are necessary to the motor. For a four-cylinder motor the Reliable measures 6 by 7 inches and weighs 15 pounds, and the makers guarantee it to start a motor from cold every time.

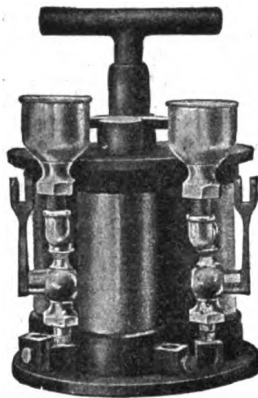

RELIABLE SELF-STARTER.

**McGiffin Windguard.**—This is an all-metal type of windshield, using a hexagonal brass frame, the latter being reamed out and lined with rubber to admit the 3-16-inch plate glass employed. This frame is attached to a hinge by two taper pins and the hinge is fastened to the base by pivoting lugs. The base can be filled with glass or hard wood. The telescoping rods supporting the windguard have balls on both ends and fit into sockets mitered and bolted to the frame at the top, and to a foot block at the bottom. These rods are operated by thumb screws, thus dispensing with the use of any tools to make adjustments. A new glass can be inserted in less than ten minutes. It is manufactured by the Automobile Specialty Company, 620 Maryland avenue, Pittsburg, Pa.

**Indicator for Autogas Valves.**—This is a handy little device that has just been brought out by the Avery Portable Lighting Company, Milwaukee, Wis., manufacturers of the Autogas tanks, and is designed to act as a regulator on the gas tank valve. It consists of a circular brass disc back of the handle of the valve, and over the face of which a spring clip passes as the stem of the valve is turned. In this disc are countersunk a number of recesses around

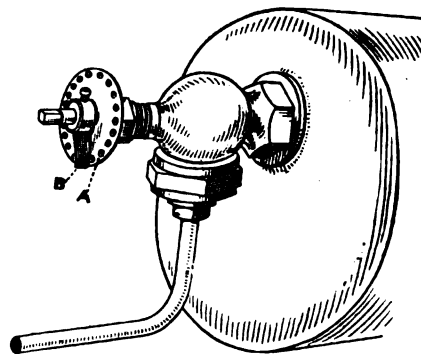

A HANDY VALVE FOR ACETYLENE TANKS.

the entire circumference and the spring clip is equipped with a punched-up boss that corresponds with these recesses, so that the opening of the valve is really accomplished by a number of short steps instead of a continuous movement. This enables the operator to learn exactly how many

notches the valve has to be opened to light a certain number of lamps, and, once this is known, it is a simple matter to remember to open the valve to exactly that point each time. The signal is audible as well as visible, as the clip makes a distinct click in dropping into each recess, so that the extent of the valve's opening is as easy to judge in the dark as otherwise. Two notches are said to represent a sufficient supply of gas for lighting two lamps.

**Dover Measure and Funnel.**—This is a new combination recently brought out by the Dover Stamping & Manufacturing Company, Cambridge, Mass., and it is one that will be greatly appreciated by the autoist, for there is probably no one thing about the tool kit of an automobile that is so frequently mislaid as the funnel. They are made in five different sizes, ranging half-pint in capacity to one holding four quarts, and are ordinarily made of extra heavy polished tin. For automobile use, particularly where wanted for gasoline, they are copper plated, and are furnished with a well-made brass wire strainer inserted. The pint size only measures 3 1/2 by 5 3/4 inches, thus making it a handy article to carry in the tool box.



DOVER FUNNEL MEASURE.

**Oxyacetylene Welding Outfits.**—The use of the oxyacetylene welding process is becoming more and more general in automobile construction, and the Beltzer Decampe Welding Company, Bridgeport, Conn., are now turning out portable outfits especially adapted for this work. These consist of a portable oxygen generator; a portable automatic acetylene generator; a blowpipe permitting the welding of sheets of every thickness up to 1 1/4 inches, and the repairing of castings of any dimensions; also a blowpipe for the rapid cutting of steel to any desired shape, it being possible to cut plates as thick as 2 inches, cross rods inserted, then a circumferential wire ring and alternate rubber section and wire ring, until the proper width is obtained with marvelous rapidity. The complete outfit weighs 700 pounds. Commercial plants capable of running six blowpipes continuously, are also made a specialty of. According to its capacity, either is particularly adapted to the welding of wrought or cast iron, this firm having discovered a special process for accomplishing the latter, steel, sheet iron work, piping, copper, etc.; repairing all kinds of castings, the making of seamless tanks, local annealing, the rapid and economical cutting of steel, beside many other uses.

**Edison Double System Spark Plug.**—This plug, manufactured by the Edison Auto Accessories Company, Thoroughfare building, Broadway and Fifty-seventh street, New York City, contains two separate electrodes, one for connection to magneto and one for connection to battery, and is intended to take the place of the double set of plugs as are now used on most cars. Cars having only one set of ignition can now have two by connecting the storage battery on one electrode and dry cells to the other. The makers claim that aside from this feature the plug cannot short circuit, and that water, oil, carbon or soot will not affect it in any way.



## SPECIAL NOTICES

Advertisements inserted under this heading at 20 cents per line; about 7 words make a line. Remittance should accompany copy. Replies forwarded, if postage is furnished.

### Cars for Sale

**A 5-TON** electric truck, made by the Electric Vehicle Company; in good shape, and extra batteries; price \$2,000. P. O. Box 115, Station A, Hartford, Conn.

**A 1907 PACKARD** touring car in A1 condition, with full equipment; price, \$3,750. Address Box 91, care The Automobile.

**A LOCOMOBILE**, 25-h.p. 1905 Model; just completely overhauled, like new; guaranteed in perfect condition. Locomobile, 151 E. 126th St., New York.

**A TOURING CAR**, seats five, good condition; complete, extras. EWELL, 898 Bedford Ave., Brooklyn, N. Y.

**A AUTO CAR RUNABOUT**, just overhauled and painted, in good condition, will be sold cheap if taken at once. Inquire 29 Main St., Bristol, Conn.

**BABCOCK** Electric Stanhope for sale; newly painted; batteries in perfect condition; motor in good running order; must be sold; the best offer takes it. Apply to F. J. Tyler, 121 Massachusetts Ave., Boston, Mass.

**BUICK** Roadster for sale at a bargain; perfect condition, new casings and inner tubes. Will let purchaser try out to satisfaction. Inquire "X. Y. Z.," care The Automobile.

**CADILLAC RUNABOUT**, 1906 Model; in fine condition; a dandy car for \$550; if you want a car with a national name this is your opportunity; act at once. Halsey Auto Co., 3908 Olive St., St. Louis, Mo.

**ELEGANT 1907 Pope-Toledo** Roadster, fully equipped with Eisemann magneto, five lamps, Prest-o-Lite tank, top, extra tire with cover, etc. One of the finest outfits in Buffalo. A bargain for quick sale. E. R. Thomas Motor Company, Second Hand Dept., 1200 Niagara St., Buffalo, N. Y.

**FOR SALE—1 Oldsmobile Runabout**, \$100; 1 large Touring Car, \$700; 1 single-cylinder Oldsmobile Engine, \$30. Auto Parts Co., 99 West Monroe St., Chicago, Ill.

**FRANKLIN**, '06 E Runabout; special 30-inch wheels; 3/4-inch tires all round; good as new; extra tire and four new inner tubes; top, gas tank, cut-out; guaranteed excellent condition; bargain, \$700. W. E. B., 1911 Oakhill Ave., Youngstown, O.

**GET WISE**—We have anything you want in second-hand cars—Packards, Wintons, Locomobiles, White Steamers, Franklins, Buicks, Oldsmobiles—and bargains at that. The Sid Black Automobile Co., 630 Walnut St., Cincinnati, Ohio.

**NEW 1908 Stevens-Duryea**, 6-cylinder, 50-h.p.; regular price, \$6,000; will sell for \$4,800. The George N. Pierce Co., Buffalo, N. Y.

**NEW AUTOMOBILES** that are strictly guaranteed, bought for cash, of overstocked manufacturers at forced sale prices, for immediate delivery and quick sale profits. They include Dolsons, Queens, Dragons, Orient Buckboards, Walthams, and numerous others. Apply for descriptive list and prices. If you are about to buy a second-hand car, do not fail to consult us. We have on our sales floors and ready for delivery, about every make of automobile there is. They are all substantial and well built cars that have been thoroughly overhauled in our shops and are equal to new both in reliability and appearance. We ask you on an average about one-fourth the original cost. They range in price from \$250 to \$3,000. We will gladly mail you our weekly list upon request. We have the largest and most complete stock of automobile supplies in America, and can give you cut prices on everything. We make a specialty of tires, have an immense stock on hand, of the best makes and can give you bargain counter prices. Send for our new 100-page catalogue and souvenir. The former is a dandy, and the latter, unique. Times Square Automobile Co., largest dealers in new and second-hand automobiles in the world, 1599 Broadway, New York, and 1322 Michigan Ave., Chicago, Ill.

**MODEL M Cadillac** Runabout; 4 new tires complete; 5 lights; new sprockets and chain; reason for selling, purchased new Cadillac touring car; no reasonable offer refused. W. L. Gray, Guilford, Conn.

**ONE 1905 French type Oldsmobile** runabout; good condition; minus tires; \$175. Frank Herbst, Wilmington, N. C.

**PACKARD 1907** model; with touring and limousine bodies, cape top wind shield, seat covers, speedometer, odometer, extra tires; run 4,700 miles; cost \$6,800; A1 condition; a bargain at \$4,050. Halsey Auto Co., 3908 Olive St., St. Louis, Mo.

**ROYAL TOURIST**, 1906 model; run less than 2,500 miles; tires in good condition; cost complete \$3,800; a genuine bargain at \$1,600; photo upon request. Halsey Auto Co., 3908 Olive St., St. Louis, Mo.

**SEVERAL Northern automobiles**, rebuilt and refinished throughout, and offered with the same guarantee as new cars. Northern Motor Car Co., Detroit, Mich.

**STEAM AUTOMOBILES**—Write for bargain list. F. W. Ofeldt & Sons, Nyack, N. Y.

**STEVENS-DURYEA** four-cylinder Model R, thoroughly overhauled; will demonstrate. Price \$800 f.o.b. Amsterdam. Greene & Warnick, Amsterdam, N. Y.

**TOLEDO** steam runabout, \$65; Rambler runabout, single-cylinder, 8-h.p., \$150; 20-h.p., 2-cylinder Winton, \$250. E. S. Youse, Reading, Pa.

**WE** are going to sell every second-hand car we have regardless of their real value, as we must have the room for other purposes. These include some exceptionally fine propositions, from two-passenger runabouts to seven-passenger touring cars. Get our list and make us an offer. E. R. Thomas Motor Company, Second Hand Department, 1200 Niagara St., Buffalo, N. Y.

**WE EXAMINE**, overhaul and repair every car that we offer for sale. We give demonstrations cheerfully. We carry the largest stock and sell at the lowest margin of profit. We always have from 100 to 250 cars to select from. Write for weekly list. Two hundred and fifty cars best standard makes—Packards, Pierces, Mercedes, Hartfords, Knox, Lozier, Stevens, Columbias, and in fact, any and every make, at fraction of list. See us first. Auto bodies of our own make and to fit any car, always ready. Broadway Mammoth Automobile Exchange, 245 West 56th St., New York City.

**WE ACT AS BROKERS** for the quick sale of second-hand cars. We charge the owners only 5 per cent. commission. In this way we get a great many bargains from owners who, for various reasons, want money rather than the car. We can put you in touch with the owner, and you can often buy at your own price. We have always on hand from 100 to 200 cars of practically every make. We issue a weekly list of cars on hand which we will mail you on application. The following are special snaps for this week: Locomobile, 20-25-h.p., 4-cylinder touring car, top, three extra shoes, speedometer, odometer, tools, lamps, etc.; cost \$2,850. Matheson 4-cylinder, 45-50-h.p. touring car for \$2,500; full lamp equipment, 2 horns (1 Gabriel), luggage carrier, 7-passenger; magnificent; cost \$5,500. Baker Electric lady's Stanhope, all working parts in good order; handsome and stylish Rainier Limousine, 28-32-h.p., with touring body and cape top, horn, headlights, etc.; originally cost \$5,500. Rapid Sight-seeing car, 1907, 12-16-passenger, top, side curtains, powerful and durable; originally cost \$3,000. Ford 4-cylinder, 1907 Runabout, can be bought for \$500 cash; has top, searchlight, speedometer, good tires; fine condition; cost \$900. 30-h.p. Apperson, 4-cylinder touring car, side entrance, 7-passenger, cape top, good tires, full set lamps; originally cost \$3,500. Pierce Racine, 16-h.p. touring car, originally costing \$1,750; detachable tonneau, good tires, full set lamps, etc. Manhattan Storage Co., 334 West 44th St., New York City.

**WHITE STEAMER**—1906, with '08 regulation equipment; double brakes on rear axles, demi-limousine body, with long doors, cape top, glass front, full set lamps; price \$1,500, complete. Address Box 39, care The Automobile.

**WINTON**, 1907 Model M; top and dust cover, tire holders and tire case; extra tire; folding glass front; speedometer and gas tank; two extra tonneau seats; Kilgore shock absorbers; cost new \$4,000; will sell for \$2,250 and guarantee in first-class condition. C. C. Stoltz, Marion, Ohio.

**WHITE STEAMER**, Model F, in excellent condition. A. F. Crittenden, 22 Main St., east, Rochester, N. Y.

**'06 K WINTON**, 35 H, top, glass front; A1 condition; \$1,050; cost \$2,600. A. L. Sheridan, La Fayette, Ind.

**\$300 BUYS** a Duryea 3-cylinder Folding Rear Seat Phaeton; wheel steer; new tires; first-class condition. Duryea, care The Automobile.

**1907 STANLEY** Steamer Model F Touring Car; high grade top, tool box, robe rail, electric gauge and tail lamp; boiler in strictly first-class condition; car thoroughly overhauled; owner going to Alaska. Full detailed information and price on request. Hawthorne Auto Co., Mason City, Iowa.

**BRAND NEW**, 4-cylinder, 24-h.p. Buick touring car, shaft drive, sliding gear transmission. Was given away as a door prize at a fair recently held in this city by the local Council K. of C. The winner of prize had option of taking machine or \$1,500 in cash. Winning ticket was held by lady; she took the money, leaving the machine with Council. First certified check of \$1,250 takes it. Prospective purchasers by coming to this city will be given demonstrations. Address M. J. Collins, Chairman Board of Trustees, Glens Falls, N. Y.

**12-PASSENGER**, 40-h.p. gasolene car; top, extra tires, etc.; good as new; great bargain, \$1,000. Tremaine, 20 Pine St., Bradford, Pa.

### Cars Wanted

**WILL PAY \$1,000** cash for first class automobile, complete, ready for use, including lamps, top, etc. Address King, P. O. Box 56, Jersey City, N. J.

**DOPE-TRIBUNE** 1905 single-cylinder wanted for low dollar. Condition secondary to price. Address Obsolete, care The Automobile.

**SECOND-HAND '07 or '08 Holsman** Surrey. State exact condition, equipment and price or no attention. Address X., care The Automobile.

**WANTED**—1907 Pope-Hartford or Stoddard-Dayton touring car. Address "Pope," care The Automobile.

**WANTED**—A-1 Touring Car (Packard preferred) seat 7. Will give first-class 40-foot gasoline cruising launch, well-known make, and reasonable amount cash difference in value. Boat seen N. Y. Send description or call. Stanley M. Seaman, 220 Broadway, N. Y.

**WE WILL PAY** full value in spot cash for your automobiles, in quantities from one to one hundred. Call or mail descriptions. Broadway Mammoth Automobile Exchange, 245 West 56th St., New York City.

### Parts and Accessories

(FOR SALE)

**AUTO TIRES**—All the best makes of tires on hand, at cut prices; a big stock of "specials" and "seconds" at "Bargain Counter Prices"; we will save you money on any make and any size; write or call. Broadway Mammoth Automobile Exchange, 245 West 56th St., New York City.

**AUTO TIRES**—New and second-hand auto tires at large discounts; expert repair work, including recovering and applying of Bailey treads, etc. Broadway Rubber Tire Works, 53 West 63d St., near Broadway, New York City. Phone 5384 Columbus.

**AUTOMOBILE TIRES**—Overstocked with second-hand casings and tubes, all sizes, right prices; tire repairing, recovering, rebuilding; best workmanship and material. All work done on short notice. Tel., Harrison 7301. Bebbler & Coen, 331 Michigan Ave., Chicago, Ill.

**FOR SALE**—300 sets 28x3 best grade artillery wheels fitted with clincher rims, less hubs; write for bargain prices on single sets or the lot. Thomas B. Jeffery & Co., Kenosha, Wis.

**BODIES**—We have a few 5-passenger touring car bodies, in two sizes: 69 1-2x34 1-2 on bottom, price \$40; 80x34 1-2, price \$50. Are new bodies, finished in Quaker green, upholstered with curled hair and genuine leather; prices cash with order, f.o.b. cars Waltham, crated. Illustration and blue-prints showing all dimensions sent upon request. We also have a few 1908 model steering columns with worm gear for sale. Waltham Mfg. Co., Waltham, Mass.

**FIRST QUALITY** guaranteed clincher casings and tubes; 28x3 \$13.50, tubes \$3; 30x3 \$14.50, tubes \$3.25; 30x3 1-2 \$17.50, tubes \$3.75; 32x3 1-2 \$18.50, tubes \$3.85. Single tube tires: 26x2 1-2 \$9; 28x2 1-2 \$10; 28x3 \$12; 30x3 \$13. Seconds \$2 less each. Vulcanizing done well; prices reasonable. Bicycle tires \$2.25 per pair. Chas. E. Miller, Anderson, Ind.

**FORD RUNABOUT OWNERS**—You can make a handsome "Roadster" of your car, with our rumble seat and trunk, glass front, new fenders with brass bound running boards, folding hood, "hood dash," etc.; send for catalogue; avoid spring rush; order now and save money. Auto Rebuilding Co., Chicago, Ill.

**KINGSTON CARBURETERS**.—Model C, 1907, new 1-1/4-inch, \$4; 1-1/2-inch \$4.50; Universal Model D, 1907, new 1-inch, \$3.50; Holley, slightly used, Model E, 1-1/4 inch, \$3; 1-1/2-inch, \$3.50; a few 1-1/4-inch Schebler, Buffalo, and Universal at \$5. McLean & Brotherton, 73 Home Bank Bldg., Detroit, Mich.

**REBUILD YOUR CAR** into "Gentleman's Roadster." We make latest style hoods, radiators, tanks, fenders, "hood dashes," glass fronts, rumble seats and trunks, etc. 20 per cent. saved, your old car redesigned free. Hood and dash outfits for '03 and '04 Ford, Cadillac and Winton in stock. State your needs for catalogue. Auto Rebuilding Co., Chicago, Ill.

**SINGLE CARBURETER OUTFITS**, '05-'06 Reo, '05-'06 Ford, Maxwell, Buick, Cadillac; also commutators, slip covers, top hoods, under shields, folding fronts, running boards, mud splashes, tire protectors. All specialties. State your wants. Jenkins Specialty Mfg. Co., Sumter, S. C.

**SPLITDORF COIL** for sale; 4-cyl., price \$20; condition excellent. Whitmore, 750 Main St., Willimantic, Conn.

**THE KING** is an auto tire that has never yet been punctured, and some of them have been ridden 10,000 miles; will outwear two rubber tires and then some; liberal commission to good salesmen. King Leather Tire Co., Racine, Wis.

**TIRES** for automobiles; brand new goods; overstocked; 28x2 1-2, \$8; 28x3, \$14.50; 28x3 1-2, \$14.80; 30x3, \$14; 30x3 1-2, \$16.50; 30x4, \$18.75; 32x4, \$20; write for other sizes; will surprise you. A. H. Kasner, 152 Church St., New York. Largest Tire Dealers in U.S.

**TIRES**—We sell any tire on the market; new casings at the following prices: 28x2 1-2, \$9 each; 28x3, \$17 each; 30x3 1-2, \$20 each; 32x4, \$26 each; 34x4, \$27 each; other sizes and tubes in proportion. Chicago Vulcanizing Co., 1463 Michigan Ave., Chicago, Ill.

**4x4 AIR-COOLED** opposed motor, new, \$75. Would take second-hand engines in trade. Comet Motor Works, Madison & Canal Sts., Chicago, Ill.

**7-H.P. OLDS ENGINE**, \$30. One Olds rear axle, \$20. One Olds front axle, \$15. Olds wheels, \$15; worm steering wheels, \$20; sliding gear transmission, \$25; planetary transmission, \$20; two-cylinder air-cooled motor, \$70; two-cylinder water-cooled motor, \$50; one set 36x2 artillery wheels with solid rubber tires, \$40. Auto Parts Co., 99 W. Monroe St., Chicago, Ill.

**\$2.00 BUYS** a durable Roadster rear seat cover, postage prepaid; \$19.50 a folding plate glass front, complete attachments. Auto Accessories Co., Box 275, Chicago, Ill.

**Parts and Accessories (WANTED)**

**WANTED**—Second-hand Orient Buckboard tires. Freedman, 2545 E. 55th St., Cleveland, O.

**WANTED**—Manufacturers, attention! Hustler in Chicago having successfully introduced automobile accessories and specialties and being favorably known to Western trade, is now open to introduce, or handle, other lines of genuine merit in Chicago and vicinity. Can prove results. Can sell parts, chassis, frames, transmissions, engines or specialties. If you have something good, address H. W. B., care The Automobile.

**Situations Wanted**

**DRAFTSMAN-DESIGNER**, desires position; long practical experience, thoroughly in touch with latest practice, and competent to assume entire charge of drafting and designing departments. For references and complete particulars, address Box 81, care The Automobile.

**ENERGETIC** man directly connected with the automobile business from its start, and thoroughly conversant with design and practice will consider change. Good opening with factory working along lines of future demand preferable. Address Box 17, care The Automobile.

**FIRST-CLASS MECHANIC** and chauffeur desires position driving; five years' experience, driving and repairing all makes of gas. cars. Sober; best references. Address Box 165, Hampton, Iowa.

**POSITION** wanted by expert auto repair man as chauffeur. Address Matthews, care of The Automobile.

**SALESMAN** calling on New England garages and dealers would like good side line. Salary or commission. Address S. C. S., care The Automobile.

**SALESMAN** wants agency for specialties, or a line suitable for the New England automobile trade. Address Box 780, care The Automobile.

**SITUATION** wanted by chauffeur; thoroughly understands his business on all cars; reference from last employer. D. A. Hupping, 115 Stagg St., Brooklyn, N. Y.

**Help Wanted**

**WANTED**—By a prominent automobile manufacturer, salesman of experience as district manager. Address, giving experience, references, and salary expected. Box 33, care The Automobile.

**Insurance**

**INSURANCE** for automobiles—Broad, safe policies at lowest prices; insurance against fire, self-ignited explosions, transportation hazards, theft, etc.; best services guaranteed, no matter where insurer is located. For particulars, address H. W. Beals, 76 William St., New York City. Phone, 3052 John.

**INSURANCE** for motor cars against every risk, including fire, explosion, self-ignition, theft, collision, accident, transportation, perils and other damages; cars insured anywhere in the world by the kind of "Policies that Protect," at the lowest rates of premiums; automobile bail bonds to cover all States; demonstrating policies for the trade. Dixie Hines, Times Building, New York City.

**Schools**

**THE AUTOMOBILE** industry offers a great opportunity for the ambitious man to secure a permanent paying profession. Its growth has been marvelous. It is yet in its infancy. New York City alone will require within two years 5,000 taxicab drivers; commercial vehicles as many more. A competent, careful driver is always in demand for pleasure cars. The supply is limited and the salaries high; the associations are first-class. You can make you a skilled driver, mechanic or salesman. Also course on automobile designing. Write us now for prospectus of terms, etc. New York School of Automobile Engineers, Inc., 146 West 56th St., New York City.

**817 MEN** who enrolled in our automobile school last season say their time and money were well invested. Our courses are thorough and practical. We have a large garage, completely equipped, and expert instructors. The school is not run to make money, but to give men a thorough course of instruction at a minimum cost. Catalog sent on request. West Side Y. M. C. A., 310 West 57th St., New York City.

**Miscellaneous**

**AUTOMOBILE TIRES** rebuilt, retreaded, relined, rim cuts and blow-outs repaired, inner tubes repaired and respiced; all work thoroughly tested before shipment, and fully guaranteed. Thomas Rubber Vulcanizing Co., 227 South St. Joseph St., South Bend, Ind.

**A 1908 M. M. Racing Motorcycle** for sale; capable of going 70 miles an hour; A-1 condition, and used less than 300 miles; \$95. H. C. Wing, Greenfield, Mass.

**CARRY A BURROWES** emergency rim or spare wheel on step of your car, all inflated ready to clamp to side of car wheel. No need of removing punctured tire till you get home. Local agents wanted. E. T. Burrowes & Co., Portland, Me.

**CHAUFFEURS**, machinists and repairmen can secure, free, a set of Bullard wrenches; write us for special offer, Bullard Automatic Wrench Co., Providence, R. I.

**CLASSIFIED LIST** all licensed automobile owners in Iowa, compiled by towns and alphabetically arranged to June 1, 1908. One dollar per copy, postpaid. Address W. J. Wallace, care Sears-Nottinger Co., Des Moines, Iowa.

**NEW PATENT** articles wanted. Inventors and manufacturers having patented novelties may secure immediate European market. We buy foreign patents for cash or manufacture on royalty, also buy the goods for cash only.

The principal member of important European business house is now in the United States. He will consider any meritorious articles that are perfected and ready for sale. New York bank references will be given. Only serious propositions will be entertained and all communications will be treated confidentially. We guarantee quick action. Do not reply unless prepared for full investigation. Address Success, Box 314 Madison Sq., New York City.

**TIRE REPAIRING** is our business, and we know that our vulcanized repairs give satisfaction to our patrons. Why not give us a trial? Once a customer, always a customer of the Model Vulcanizing Co., 1547 Michigan Ave., Chicago, Ill.

**TIRES REPAIRED**—Automobile owners, do you want your tires repaired or recovered by people who know how? Give us a trial and be convinced. Inner tubes vulcanized at short notice. Jungkind & Vogler, 158 Chambers St., New York City. Telephone, 3386 Cortlandt.

**TIRES REPAIRED** and retreaded—All work guaranteed. We have the largest and best-equipped tire repair shop in the West, and experienced men to do the work. Best materials and workmanship only. A complete line of Morgan & Wright tires carried in stock. Auto Tire Co., agents Morgan & Wright, 605-7 East 15th St., Kansas City, Mo.

**W. M. SANFORD, JR.**, dealer in Automobile Tires, 42 West 67th St., New York. Perfect, scientific and honest repair work a specialty.

**BARGAINS IN 1908 Tires Guaranteed**

first quality, fresh stock at unheard of reductions, made by the most prominent tire makers in the U. S.

**CLINCHER CASINGS FOR G & J OR UNIVERSAL RIMS**

28x3 Casings, \$12.00	Tubes, \$3.00
30x3 " 13.50	" 3.50
30x3 1/2 " 16.50	" 3.75

Other Sizes in proportion. Write for list.

We can sell any make tire for less money than any dealer in America

**Excelsior Tire Co.**  
1777 Broadway, New York



# NOW READY FOR DELIVERY

## The OFFICIAL A.A.A. AUTOMOBILE BLUE BOOK

Published in four volumes—each volume complete in itself

**1908 NEW YORK SECTION**  
SECTION No. 1  
667 Pages. Size 5 1-2 x 9 1-2 Inches.

**1908 NEW ENGLAND SECTION**  
SECTION No. 2  
770 Pages. Size 5 1-2 x 9 1-2 Inches.

**NEW JERSEY-PENNA. SECTION**  
SECTION No. 3  
608 Pages. Size 5 1-2 x 9 1-2 Inches.

**Blazes the Way, North, East, South and West**  
Covering Approximately 65,000 Miles of Roads



Actual size each volume 5 1/2 x 9 1/2 inches

The official and recognized authority—newly revised and enlarged for 1908 with wider scope and more details. The most complete and accurate ever published. All the best and most popular routes, best accommodations in hotels and garages, with full running directions and maps for nearly every route described.

Total distances between towns and a complete index of all important towns located on separate routes, and also index of through trips on trunk lines between principal cities and points of interest. A fund of information—

### INDISPENSABLE TO AUTOMOBILISTS

**SECTION No. 1**—Covering New York State, Lower Canada and Trunk Lines to the Middle West.  
NOW READY

**SECTION No. 3**—Covering New Jersey, Pennsylvania, Delaware, Maryland and Trunk Lines to the Middle West.  
NOW READY

**SECTION No. 2**—Covering NEW ENGLAND with extension Routes into the Provinces.  
NOW READY

**SECTION No. 4**—Covering the Middle West, with Extensions to Most Important Points, North, East, South and West.  
READY SOON

Orders taken now for complete set or single volumes

The improvement in these 1908 editions is so great—nearly fifty per cent. rewritten with new mileage—that it is well worth the while of every motorist to buy the new editions rather than try to travel with the old ones.

**Bound in Genuine Leather. Price, Each, \$2.50 Prepaid**

*For sale at all book stores and by the sole publishers*

**THE CLASS JOURNAL CO., Flatiron Building, New York**



Subscribe for the Automobile. \$3.00 per year

### PORTABLE AUTO BATTERY LAMP

CONVENIENT—SAFE

PASSES THROUGH 1 1/4-INCH HOLE  
LAMP FULLY PROTECTED.

LIGHT ON WORK AND NOT IN FACE

Price, \$1.50

Postage, 10c.

**CHASE-SHAWMUT CO.**

NEWBURYPORT, MASS.

Send for Descriptive Circular



# OUTFITS AND SUPPLIES

## Forgings, Mountings and Trimmings

Articles made exclusively for individual manufacturers: Carriage type of Lamps for Limousines, Broughams and Taxicabs. Electric Cigar Lighters, Push Button Switches, Security Locking Handles. Electric Megaphone Speaking Tubes, Dome Lights and Batteries, Corner Lights.

C. COWLES & CO., New Haven, Conn.

FOUND AT LAST. I keep my Automobile accounts in DUNHAM'S AUTOMOBILE EXPENSE BOOK. It is business-like to the core. 76 pages—20 departments—everything by itself. I like it. You would, but if not, return it and they will your dollar, or send for circular. Sold only by

THE DUNHAM PRESS  
Bridgeport, Conn.



**MOTORLUBE OIL**  
PROTECT YOURSELF  
NO CARBON  
BACKED BY \$1,000 GUARANTEE  
E. A. TYGERT CO., 614 Chestnut St., Phila., Pa.

## HOLLEY CARBURETORS \$2.25

We have a stock of 1907 Model L 1" carburetors, over-run on manufacturing order. Will sell at above price while they last.

HOLLEY BROS. CO., Detroit, Mich.

**POCKET Battery Ammeter**  
0 to 30 Amperes  
Indicates in any position and in either direction of current. In testing single cells, the cord is not necessary.  
Price, \$3.50  
Eldredge Elec. Manufacturing Co., Springfield, Mass.

**SUPPLIES**  
OF EVERY DESCRIPTION FOR AUTOMOBILE AND MOTORIST  
Send for Illustrated Catalog and Price List  
**JAS. L. GIBNEY & BROS.**  
211-213 N. Broad St., PHILADELPHIA, PA.

WHEN WRITING TO ADVERTISERS PLEASE MENTION THE AUTOMOBILE.

**U.S. METAL POLISH**  
FOR POLISHING GOLD, SILVER, PLATED WARE, NICKEL, TIN, BRASS, COPPER, ETC.  
DIRECTIONS: Take a little of the Polish on a soft cloth, rub the Metal hard and then wipe it off with a dry cloth.  
Sole Prop. 205 W. WALTON ST. INDIANAPOLIS, IND.

**METAL POLISH**  
Highest Award  
Chicago World's Fair, 1893.  
Louisiana Purchase Exposition  
St. Louis, Mo., 1904.  
3-oz Box for 10 cents.  
Sold by Agents and Dealers all over the world. Ask or write for FREE samples.  
5-lb. Pails \$1.00.  
**GEO. W. HOFFMAN**  
Expert Polish Maker  
Indianapolis, Indiana.  
Sold by Dealers.  
New York City Office, 1-3 Park

**DUPLEX WIRE TERMINALS**  
PREVENT LOOSE WIRES & POOR CONNECTIONS  
SIZES FOR BATTERY PRIMARY AND SECONDARY WIRES CARRIED IN STRUCK.  
Send 50 cents for Assorted Package  
FLEXIBLE BATTERY CONNECTORS.  
THE BLISS-CHESTER CO. PROVIDENCE, R.I.

**HOPEWELL TIRE CASE**  
All Styles—All Sizes  
FABRIC SUPPLIES, ROBES, TOOL ROLLS, VEST PROTECTORS, ETC., AT ATTRACTIVE PRICES  
HOPEWELL BROS., Cambridge, Mass.

**DON'T GO** by appearance! It may not be a new one—maybe it's a last year's car restored with  
**AUTO-SHINE,**  
a varnish polish and leather renovator that assures long life and a youthful appearance to any car. WON'T COLLECT DUST.  
Sample for 5c postage  
THE AUTO-SHINE CO., P. O. BOX 94, BUFFALO, N. Y.

**CANDY CARBIDE**  
Trade Mark  
No more trouble with generators. Sold only in 10 lb. cans, with green labels. Price \$2.00 each, from all Auto Supply Houses. A 10 lb. can, 5"x12", will make gas enough to fill up two of the largest gas tanks in the market.  
**ACETYLENE GAS ILLUMINATING CO**  
105 Walker Street, New York

Automatic The "NATIONAL"  
GIVES A PERFECT COMBUSTIBLE MIXTURE OF GASOLINE AND AIR AT ALL TIMES regardless of Engine speed, condition of atmosphere or whether run on low throttle or wide open.  
The National Auto Accessory Co.  
Office 84 State St., Boston  
Factory at Merrimac, Mass.  
For 1908

**1908 Catalogue** OF **Automobile Supplies**  
396r Olive St., St. Louis, Mo., U.S.A.  
Behen-Faught Motor Car Equipment Co.

**"Remy Magneto"**  
Means absolute reliability of the ignition system.  
Investigate for your 1908 car.  
**REMY ELECTRIC CO., Anderson, Ind.**

**THE CATERPILLAR FLAME COIL** The only coil producing a Magneto Spark  
Low Battery Consumption. Proof against break down. Synchronised action  
Write for particulars  
**Pfanstiehl Electrical Laboratory**  
NORTH CHICAGO, ILL.

The A. B. C. of Dust Proof Oil Hole Covers, learned in the school of experience. Get busy. Join the Class.  
Style B Style C Style A  
**C. F. TUCKER, Hartford, Conn.**

Test your batteries with a meter that is accurate, durable and guaranteed.  
**ROBERT VOLT-AMMETERS, \$6.00**  
" VOLT-METERS, \$4.00  
" AMMETERS, \$4.00  
including leather case  
SEND FOR CATALOG  
**ROBERT INSTRUMENT CO.**  
66 Shelby St. Detroit, Mich.

**Rotary Pumps**  
for Circulation of Water and Oil on Automobile, Marine or Stationary Engines, and for bilge purposes. All sizes and capacities.  
Send for Catalogue.  
**The LIPMAN MFG. CO.**  
210 Pleasant Street, Beloit, Wis.

**CULLMAN SPROCKETS**  
and Differentials in stock and to order also. Baldwin, Diamond and Whitney Chain.  
Send for new Catalog.  
**Cullman Wheel Co.**  
1027 Dunning St., Chicago

**"GLOBE" IS THE POLISH**  
THE POLISH  
**FOR ALL METALS**  
**RAIMES & CO., New York, N. Y.**

**STOP**  
Hand Pumping. Attach our HILL CLIMBING PUMP on your '03-'04 White Steamer.  
Send Complete—Easily Attached.  
242 Prospect St. Boston, Mass. **EDW. S. CLARK**

**GEISZLER STORAGE BATTERY**  
NON-SULPHATING  
6 Volt, 60 Ampere Hour  
Price, \$15.00  
GUARANTEED FOR ONE YEAR  
Send for Catalog A  
**GEISZLER BROS., 316 W. 42d St., New York City**

**TRIUMPH GAGE** FOR **Gasoline Tanks**  
**BOSTON AUTO GAGE CO.**  
10 Waltham Street BOSTON, MASS

# Automobile Wheels and Axles

**SALISBURY WHEEL & MFG. CO.**  
MANUFACTURERS  
JAMESTOWN, NEW YORK

## AUTOMOBILE TURNTABLE

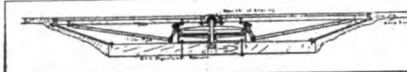

Patented December 28, 1906  
The easiest running table made. Built strong, and the heaviest cars can be turned with ease.  
PRICE OF TABLE COMPLETE: 10 feet, \$150; 12 feet, \$175; 15 feet, \$225. Ask for Testimonials.  
**PORTLAND GARAGE CO., Portland, Me.**

## MILLER GREASE GUN

Four-in-One  
The Standard of the World

Quick operating, Self-filler, Ejector and Cup Filler  
The gun that always stays, always leads, always improves, always outwears and always outsells all others, is the "MILLER."  
No other Gun equals it—bold claim; but there's proof aplenty. Ask your hardware dealer or will mail you a gun on receipt of \$3.00. Orders filled same day received.  
**MILLER & STARR, 250 Greene St., Brooklyn, N.Y.**



## The RAYMOND BRAKE

ROYAL EQUIPMENT CO.  
155 Housatonic Ave. Bridgeport, Conn.

## Automobile Supplies AT LOWEST PRICES

Get our Illustrated Catalogue and save time, trouble and money  
**MANHATTAN STORAGE CO.**  
1611 Broadway NEW YORK



Charge your ignition battery at home from an alternating current with a  
**RUPRECHT CORRECTOR**  
Cheap, durable and efficient; saves your time, money and battery.  
**THE AUTO & SUPPLY CO.**  
Dept. A Cuyahoga Bldg. Cleveland, O.

## Jones Speedometer

The pioneer and accepted standard  
Automobile Speed Indicator  
Write for catalog

**JONES SPEEDOMETER**  
76th Street and Broadway, NEW YORK  
Chicago, 1287 Michigan Ave. Detroit, 222 Jefferson Ave.  
Philadelphia, 299 N. Broad St. Cleveland, 2441 Euclid Ave.

## EBERMAN AUTO POWER TIRE PUMP

Will inflate your tire in less than two minutes.  
Attaches permanently to any car. Always ready when needed. Entirely concealed from sight. Weighs only five pounds.  
Price complete, \$15.00  
**Eberman Auto Appliance Co.,**  
1265 Monadnock Block, CHICAGO Patent Applied For

## THE STANDARD GARAGE EQUIPMENT FOR GASOLINE STORAGE

# THAT'S THE BOWSER

Send for Catalog J  
**S. F. BOWSER & CO., Inc.,** Fort Wayne, Ind.  
NEW YORK BOSTON CHICAGO TORONTO

## WEEBER WHEEL PULLER

The most useful tool for factory or repair shop for removing rear wheels from automobiles, so as not to injure wheel, axle or bearings. With the Weeber Device the pressure is so strong and steady that the tightest of wheels will be removed without injury to end of axle, and the grip is spread so uniformly around wheel as to make it impossible to injure wheel or fash. One Puller fits all size wheels, \$16.50. Special size to fit over extra large hub, made to order without extra cost. Write us.

C. E. WEEBER MANUFACTURING WORKS, ALBANY, N. Y.

## ALBERT CHAMPION CO.

36 Whittier St., Boston, Mass.  
Manufacturers and Importers  
**IGNITION SUPPLIES**  
CHAMPION High Tension MAGNETO  
Champion Spark Plugs  
Imported Ignition Wire

## STANDARD

(Trade Mark)  
**SPEEDOMETER**  
Accuracy and durability guaranteed. Hand is absolutely steady at all speeds.  
40-, 60-, 80-mile instruments.  
Send for catalogue and prices. Agents wanted.  
**PARKER MFG. CO.,** 6 Clifton St., Boston, Mass.

## Positive Lubrication Assured

We make anything you want in a Mechanical Oiler. Our Oilers excel all others both in price and service. Let us prove it. Sent on approval to Auto and Motor Boat manufacturers. Write us before ordering elsewhere.  
**STANDARD AUTOMATIC LUBRICATOR CO.**  
371-373 Ellicott St., Buffalo, N. Y.

## EXPANDED METAL LOCKERS

Sheet Steel Material Closets  
**MERRITT & CO.**  
1045 Ridge Ave. PHILADELPHIA, PA.

**F. W. OFELDT & SONS**  
Nyack-on-the-Hudson, N. Y.  
Manufacturers of  
Blue Flame Kerosene Burner  
Safety Water Tube Boiler  
Automatic Water Regulator  
Automatic Fuel Regulator  
Feed Water Heater  
Compound Steam Engines  
Our Kerosene Burner works to perfection on  
White Steamers

## WRITE FOR NEW CATALOGUE

**THE AUTOMOBILE SUPPLY CO.,**  
1336 MICHIGAN AVENUE,  
CHICAGO.  
SPECIAL ATTENTION TO MAIL ORDERS

Complete Course  
**Automobile Instruction**  
Invaluable to the owner or prospective owner of a motor car  
**Practical and to the Point**  
Send for Prospectus to the  
Correspondence School of Motor Car Practice, Tarrytown, N. Y.

# BOILERS

FOR STANLEY STEAM CARS  
Also Grout, Prescott, Locomobile and Mobile Boilers, all guaranteed to fit plated steel tubes  
Special boilers 1 to 60 H.P.; repair work. Write  
**Steam Carriage Boiler Co., Oswego, N. Y.**

**Spring Winder**  
Winds all kinds, sizes and shapes. Thousands in daily use. Two sizes  
Price \$1 and \$1.50  
**Remington Tool & Machine Co.**  
Boston, Mass.

**"E.&J." Lamps**  
Gas and Oil Side-lights.  
Our 1908 Catalogue mailed on request.  
**The Eamonds & Jones Mfg. Co.**  
DETROIT, MICH

If you want good circulation on your automobile, launch or motor boat, use a  
**LOBEE PUMP**  
**LOBEE PUMP AND MACHINERY CO.**  
230 Terrace Buffalo, N. Y.

## Engines and Clutches

MADE BY THE  
**NORTHWAY MOTOR & MFG. CO.**  
Detroit, Mich.  
are the lowest in price and the best in material and workmanship.  
**4 CYLINDER 4 CYCLE**

## Porox Ignitor Storage Batteries

Put up in celluloid jars  
Guaranteed to give satisfaction. Write for price list.  
Manufactured by  
**ALBERT MÜLLER**  
145 West 40th Street  
New York City

Let us send you a **DUPEX COIL** to use on your car 30 days free in place of your present coil. If the Duplex Coil doesn't cure 90% of your engine troubles, send it back collect, and replace your old coil. Write on your business stationery, giving name of car, number of cylinders, and any good reference and we'll send you a Duplex Coil by first express. Address  
Station N. Duplex Coil Co., Fond du Lac, Wis.

**The COTTA  
"CLUTCH TRANSMISSION"**  
Made in various sizes suitable for  
Touring Cars and Trucks. For  
shaft or double side chain drive.  
Write for information on what you require.  
**CHAS. COTTA, Rockford, Ill.**

"THE KING OF NOISE-PRODUCERS"  
**THE  
SIRENO  
HORN**  
THE SIRENO COMPANY  
39-41 Cortlandt Street, New York City

**THE LOCKWOOD  
PRIMER** WILL GIVE YOU  
AN EASY START  
Write for trial offer to-day.  
**LOCKWOOD BROS.**  
103 W. Pearl St. JACKSON, MICH.



**POYER**  
MAGNETO AND PUMP SPRING  
PLUG  
ALL IN ONE  
A NEW INDESTRUCTIBLE  
**MICA PLUG**  
WITHOUT ASBESTOS  
PACKING or COPPER  
GASKETS—LEAKAGE  
IMPOSSIBLE. OUR  
GUARANTEE ON  
THIS PLUG IS UN-  
LIMITED.  
**\$1.50** ANY  
THREAD  
SOLD AND RECOM-  
MENDED BY ALL  
FIRST CLASS  
DEALERS.  
The Trade Supplied by  
**THE MOTOR CAR EQUIPMENT CO.**  
55 WARREN STREET, NEW YORK

**PACKARD ENAMELED IGNITION CABLE**  
  
Is now regarded an important feature in  
all high-grade automobiles and motor boats.  
Send for descriptive circular of our new  
**MULTIPLE LOW TENSION CABLES.**  
**THE PACKARD ELEC. CO., WARREN, O.**

**Construction of a Gasoline  
Motor Vehicle**  
By C. C. BRAMWELL. Contains 150  
pages, 6 x 9; one hundred illustrations  
and diagrams. Publisher's price, \$2.00;  
our price, 50 cents. Address The Auto-  
mobile, Flatiron Building, New York.

**TRUFFAULT-HARTFORD  
Trade  
SHOCK ABSORBER  
Mark**  
The Device that made Safe, Speedy and Com-  
fortable Automobiling Possible.  
Write for Rough Road Booklet to Department C  
**HARTFORD SUSPENSION COMPANY**  
E. V. Hartford, Pres. 140 Bay St., Jersey City, N.J.

**This Is It**  
**A Perfect  
Plug**  
We Guarantee It  
**FOR ONE YEAR**  
against defects or  
broken porcelains  
It has made 'em sit up  
and take notice.  
**JUST INSIST ON  
Never-Miss No. 8**  
Any Size  
Can take apart in one  
minute  
**Simple, Efficient &  
a year's wear for  
\$1.00**  
Don't let the dealer  
hand you a lemon. Tell  
him you want what you  
want and it's a  
**NEVER-MISS No. 8**  
Direct for \$1.00 if you  
can't get it there.  
**Never-Miss Spark  
Plug Co.**  
Lansing, Mich.



# Automobile Catechism

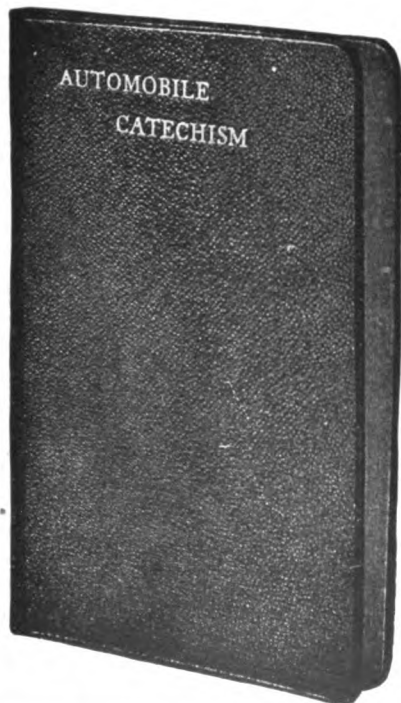

**For the Use of Owners and Drivers of Cars  
Fitted with Internal Combustion Motors**

By **FORREST R. JONES, M. E.**  
President of the Manhattan Automobile School

Size 4½ by 7 inches.

Pages, 134

With Drawings

Price, in Genuine Morocco Cover, Gilt Edges, \$2.00, including postage

**THIS** is the most practical, up-to-date work on the subject in the English Language. It is published in pocketbook form, with high-grade leather cover, and printed on especially tough paper, as it is intended to be the inseparable companion of the autoist when on tour. Not a line is wasted on obsolete constructions or descriptions of unfamiliar apparatus. It treats of the automobile in modern form and of all the troubles that may arise in the course of ordinary use and that may be remedied by the driver himself. It is written in plain language and is the most helpful, authoritative, and comprehensive manual that has yet appeared. The subject matter is in the form of question and answer, and an exhaustive cross index makes immediate reference possible in any particular case.

ORDER FROM THE PUBLISHERS

**THE CLASS JOURNAL COMPANY**

Flatiron Building

Madison Square

New York City



**Use KIRK'S OIL**  
**IT BEATS 'EM ALL**  
 A new superior lubricant for automobiles, motor boats and all makes of gasoline engines.  
**SPECIALLY FILTERED**  
 Free from carbon impurities, yet has sufficient body for perfect lubrication.  
**SEND FOR CIRCULAR AND PRICES**  
**L. B. KIRKPATRICK**  
 231 Alexander St., ROCHESTER, N.Y.

**AMCO BUMPER**  
 ADJUSTABLE. — WILL FIT ANY CAR  
 THE only bumper that will take corner-wise jolts without breaking bumper or springing car. Gives positive protection against smashed lamps and punctured radiators. Ask your dealer to show how it works—but insist on AMCO. Its special features make it BEST. Write for prices and booklet showing AMCO Bumpers, Tire Holders, Exhaust Horns, Robe and Foot Rails, Garage Electric Pumps, etc. Appliance Manufacturing Co., 62 W. Van Buren St., Chicago



Patented

**"BREECH-BLOCK" PLUG**  
 WITH IMPROVED CLIP and HANDLE  
 IF you are not particular, any old plug will do, but if you want the Best Plug, a plug that is always dependable—insist on the "Breech-Block." Write for full particulars or let us send you a sample Plug.  
 The Standard Co., Torrington, Conn.



**20TH CENTURY TIRE PROTECTOR**  
 Absolute Tire Protection  
 No possibility of Punctures, Blowouts, or Skidding, as the "20th Century" protector not only covers the tread but the ENTIRE TIRE. Protecting it from water, sand, rock, etc., which always get between the tire and protector in other makes. Our patent mechanical way of attaching them to the tire makes them fit perfectly. They cannot budge after once on the tire. Made of finer and heavier material than any other. They cost a great deal less than a regular tire and will wear four or five times as long. Automobilst.—You need this. It will save Money, Time and Trouble. Let us explain full details of its many advantages over all others. Write for full particulars to-day.  
 THE PERKINS-CAMPBELL Co., Licensed Manufacturers  
 622 Broadway, Cincinnati, Ohio



**Quality Counts**  
 There are many reasons for the popular endorsement of the BROWNELL Gasoline Motors. Ask any user, or write us, and we will tell you all about it  
 4, 6 and 8 cylinders. 14 to 150 H.P.  
**F. A. BROWNELL MOTOR COMPANY**  
 634-636 Lexington Ave., Rochester, N. Y.

WHEN WRITING TO ADVERTISERS PLEASE MENTION THE AUTOMOBILE.

**Touring days are coming**  
 And you'll be constantly planning attractive outdoor luncheons—no matter where you go or how long you stay, you may have all the satisfying comforts of cool, fresh, appetizing food and drink if your luncheon is packed in a  
**Hawkeye Refrigerator Basket**  
 Special Pattern for Automobiles  
 An ideal refrigerator encased in a handsome, durable wicker basket that can be locked. Non-rusting metal lining, interlined with asbestos and hair felt. Ice compartment easily removed. Damp proof. Ask your dealer for a Hawkeye Refrigerator Basket. If you cannot obtain it send us his name and we'll see that you're supplied. Our illustrated booklet, "The Ice Cold Hawkeye," free for asking.  
**Burlington Basket Co., 202 Main Street, Burlington, Iowa.**



**WICO Adjustable Spark Plug**  
**\$1.00**  
 Each  
 Guaranteed one year.  
 Witherbee Igniter Co., 1876 B'way, New York



**The Practical Gas Engineer**  
 WHAT TO DO AND HOW TO DO IT.  
 A book of 150 pages, neatly bound in cloth. Sent postpaid for \$1.00. Address The Automobile, Flatiron Building, New York.

**Triumph Valve Remover Adjustable Ball Joints**  
 HERE IT IS IN ACTION  
 No waste of time  
 No broken finger nails. Fits any Gasoline Engine.  
 Patented April 24, 1905  
 P. O. Order for \$1.00 and the Remover will be sent you postpaid.  
 Manufactured by  
**MECHANICAL & ELECTRICAL MFG. CO. 50 N. Desplaines St., CHICAGO**

Enables you to remove valve key or valve spring with no side strain or bending of valve stem. Price, \$1.00 each. Discounts to manufacturers and jobbers. For sale by supply dealers throughout the United States. If your dealer cannot supply you send us your name and we'll see that you're supplied. Our illustrated booklet, "The Ice Cold Hawkeye," free for asking.  
 for throttle and spark levers, connecting carburetor and timer with levers on wheel steer, eliminating all lost motion and giving a more perfect control to these levers at all times Easly and perfectly adjustable. Adjustable stock size, steel, 40c ea. Adjustable stock size, brass 50c ea. Non-adjustable stock size, steel, 20c ea.  
 PRICE, 40c  
 Cut shows exact size



SCREW  
 SOCKET  
 BALL  
 D 5/16 T 18  
 D 10 T 32  
 PAT. PEND.

For Spark & Throttle Levers

**HOW TO RUN AN AUTO**  
 Are You Interested in Automobiles?  
 If you are, an early purchase of "HOMANS' SELF-PROPELLED VEHICLES" will prove a good investment.  
 This work is now the accepted standard on the practical care and management of motor cars explaining the principles of construction and operation in a clear and helpful way, and fully illustrated with many diagrams and drawings.  
 The presentation of subjects has been determined by consideration of the needs of the man behind the wheel. It is clear and concise in its treatment and comprehensible to the most inexperienced automobilist, at the same time it is so thorough that the expert will learn much from its pages.  
 This good book will be sent to any address in the world postpaid, upon receipt of two dollars, or if desired, will be sent on approval to be paid for after examination.  
 Contains 608 pages, over 600 diagrams and illustrations, printed on fine paper, size 8-4 x 11-2 inches with generously good binding.  
 Highly endorsed.  
**AUDEL & CO.**  
 No money in advance required, sign and return  
 Theo. Audel & Co., 65 Fifth Ave., N. Y.  
 Kindly mail me copy of "Homans Auto," and if found satisfactory I will immediately remit \$2 or return book to you.  
 Name..... Address..... Date.....

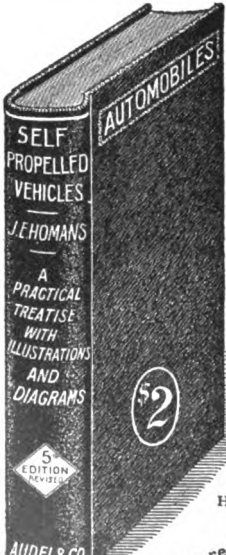

**PROOF OF MERIT -**  
**"CLEANOLA"**  
 To convincingly prove to every skeptical owner that "CLEANOLA" OIL POLISH is far superior to anything in the world for cleaning, brightening and renewing the fine finish of your car after each run, we will send a sample FREE. "CLEANOLA" restores the surface and "shine" they wore when new, to the varnished wood and metal work, leather trimmings, cushions and tops  
 "CLEANOLA" prolongs life and greatly improves their appearance. If you are not already a user of "CLEANOLA" we will send you a sample free that you may test its value  
 Write to-day. A request carries no obligation. All inquiries answered promptly.  
**THE CLEANOLA CO., 53 W. Van Buren St., Chicago; 1101 Fulton Bldg., Pittsburgh**  
**- SAMPLE FREE**



**AUTO-TOP FABRICS** OF EVERY DESCRIPTION  
 SAMPLES AND PRICES ON REQUEST  
**L. J. MUTTY CO., Boston**



The Oldest Manufacturers of Bow Sockets in the World  
**THE ASHTABULA BOW SOCKET COMPANY**  
 ASHTABULA, OHIO

**LASCO FOLDING GLASS FRONT**  
 Simple, effective, correctly designed mahogany finish wood frame—trimmed in brass—3/16 crystal plates—steel stay rods—bottom of frame shaped to dash of any standard automobile—can be attached easily and quickly. We make the London Tops. Write for details and prices.  
**London Auto Supply Co., 1221 Michigan Ave. CHICAGO**

**S. N. BROWN & COMPANY**  
 DAYTON, OHIO  
 THE ABOVE ARE THE DIFFERENT SHAPES WE MAKE  
 MANUFACTURERS OF  
**Automobile and Vehicle Bows**

**THE 3 BEST**  
 Divided  
**Windshields**  
**VOLTZ BEECHER SCHILDBACK**  
 A shield for everyone Write for prices  
 Limousine Carriage Mfg. Co.  
 3511 Michigan Av., Chicago

**Blasier Tops and Fronts**  
  
 For the best and most practical. Exclusive Blasier features and quality.  
 Write for Catalog and price list.  
**M.E. Blasier Mfg. Co., 69 Columbia St., Utica, N. Y.**

**SIMPLEX CARS** Immediate Delivery  
 Bodies Repaired, Trimmed and Painted  
 Chassis Repair Department  
**J. M. QUINBY & CO.**  
 Automobile Body Builders NEWARK, N. J.

**AUTOMOBILE TOPS**  
**\$14.00 AND UPWARDS**  
 Write for Catalogue and Prices  
**BUOB & SCHEU** 1555 Court Street Cincinnati, Ohio

**CLEAN YOUR AUTO TOPS with**  
  
**TRADE MARK**  
**ZE-NOLE**  
 MARK  
 GUARANTEED, NOT TO INJURE RUBBER, INTERLINING  
 ONE QUART, CLEANS YOUR TOP  
 PRICE, \$1.00  
**F. S. Carr, 74 Pearl St., Boston, Mass.**  
 Makers of High Grade Top Materials

**AUTO-MOBILE TOPS**  
  
**C. G. MEYER & SON, Manufacturers**  
 Established 1875  
 83 MAIN STREET, TIFFIN, OHIO

**STANDARD TRUNK RACK**  
 Double folding, made of Best Steel, and finished in Black Enamel. PRICES RIGHT.  
**CONNECTICUT STEEL & WIRE CO.**  
 HARTFORD, CONN.

**AUTOMOBILE BODIES**  
  
**THE BARNDT-JOHNSTON AUTO SUPPLY CO.**  
 Columbus, Ohio.

**EDISON**  
**DOUBLE SYSTEM SPARK PLUG**  
 .. \$2.50 ..  
**EDISON AUTO ACCESSORIES CO.**  
 1779 BROADWAY NEW YORK CITY

**MYERS PERFECT FITTING TOPS**  
 Made of best material and by skilled workmen.  
 Assured by a guarantee that they won't sag or break. That is what you want. A postal will bring you samples and prices.  
  
**MYERS AUTO TOP CO., First St., Dayton, O.**

**NOW READY**  
**THE AUTHENTIC** and Latest Style in Searchlights for Nineteen-eight.  
 Write for Details  
**Manhattan Screw & Stamping Works**  
 West End Ave. and 67th Street, N. Y. City

**IT FITS THE POCKET**  
  
 Our 1908 Catalogue No. 391, containing 112 pages brimful of illustrations and detailed description of all kinds of supplies for all kinds of cars. It is the most attractive publication of its kind ever issued and a postal card will bring it.  
**Automobile Accessories**  
 Dragon Horns, 6 1/2 in. \$5.00  
 Spark Plug Wrenches . . . . .50  
 Spark Plugs that are right .25  
 Goggles, Silk Collapsible .50  
 Battery Connections, doz .15  
 License Hangers . . . . . 1.00  
 Screw Jacks . . . . . 1.00  
 Compound Pumps . . . . . 2.75  
 Button Tire Cases . . . . . 2.50  
 Tube Patches, Box 10, .75  
 Trunk Racks . . . . . 4.00  
 Kits of 30 Tools . . . . . 8.50  
**NEW YORK SPORTING GOODS CO.**  
 17 WARREN STREET NEW YORK U.S.A.

**TAKE THE DUST OUT OF YOUR EYES**  
 BY USING  
**THOMPSON'S EYE WATER**  
 ALL DRUGGISTS

**WOODWORTH**  
 Detachable TREAD Adjustable  
 "Saves More Than Half" the Tire Bill  
**LEATHER TIRE GOODS CO.**  
 NEWTON UPPER FALLS, MASS.  
 New York Store, 1662 Broadway

**MICHELIN**  
**MICHELIN TIRE COMPANY**  
 MILLTOWN, N. J.

**The New Motz Non-Skid Cushion Tire**  
 Fits Universal and Standard Clincher rims. We furnish a tool for applying. Send for circular J.  
**The Motz Clincher Tire & Rubber Co.**  
 Akron, Ohio

**PIRELLI**  
 That Wonderful Italian Tire  
 296 BROADWAY, NEW YORK

"THE CAR THAT CONTINUES TO MAKE GOOD"

# Acme

ACME MOTOR CAR COMPANY, Reading, Pa.

## The CHADWICK Cars and Motors

MADE BY  
Chadwick Engineering Works  
POTTSTOWN, PA.  
SEARCHMONT REPAIR PARTS FOR SALE

## Imperial Roadster

The Car with the Straight Line Drive  
30-35 H.P., 36" wheels, selective type transmission, Risemann Magneto, double system of ignition double drop frame. Price including gas lamps and generator, horns, tools, etc., \$2,500.00.  
IMPERIAL MOTOR CAR COMPANY  
Members A. M. C. M. A. Williamsport, Penn., U. S. A.



No more wiring on an  
**ADAMS-FARWELL**  
five-cylinder car than one  
lungers of other makes.  
The Adams Co., 564 3d St., Dubuque, Iowa

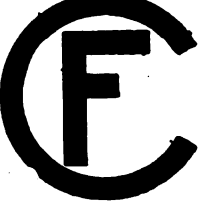

The Greatest Value Ever Offered  
**\$2,250**  
4 Cylinder 35 H.P. Motor  
**Cornish-Friedberg Motor Car Co.**  
1233 Michigan Avenue CHICAGO

A SUPERB LINE OF CARS—  
**The JACKSON**  
"No Sand too Deep—No Hill too Steep"  
2 Cyl. and 4 Cyl.  
Runabouts, Roadsters, Touring Cars  
15 H. P., 24 H. P., 35 H. P.  
Prices \$850, \$1,250, \$1,500, \$2,000  
Jackson Automobile Co., Jackson, Mich.

# Aerocar

4-cylinder, 20 horsepower, 4 passenger,  
104-inch wheelbase, \$1,500. Greatest value  
ever offered. Write.  
**AEROCAR MOTOR CO.**  
DETROIT, MICH.

## THE CAR De Luxe

## THE LAMBERT 18

"FRICTION FLYER"  
**\$800**  
Write for catalogue describing our full line  
**THE BUCKEYE MFG. CO.**  
Anderson, Ind.

# Atlas

Two-Cycle Perfected  
Is What SELLS To-day  
Atlas Motor Car Co., Springfield, Mass.

## THE EARL LIGHT ROADSTERS

2 Cylinder - - \$ 985  
4 Cylinder - - 1200  
**EARL MOTOR CAR COMPANY**  
Kenosha, Wisconsin

The *Locomobile*  
Co. of America  
BRIDGEPORT, CONN.  
A. L. A. M.

## THE "AURORA"

RUNABOUT  
**\$775—20 H.P.**  
Commercial Wagon, \$1,000—20 H.P.  
LIVE PROPOSITION TO AGENTS  
**AURORA MOTOR WORKS, Aurora, Ill.**

The Frayer-Miller  
**Air-Cooled** By Forced Blast through  
Jackets around Cylinders  
**THE CAR OF THE FUTURE**  
Pleasure and Commercial  
Cars for all requirements  
**The OSCAR LEAR AUTOMOBILE CO.**  
SPRINGFIELD, OHIO

**Exclusive LOGAN Features**  
4—Every point of friction carried on a  
ball or roller bearing  
For other features write for catalog to  
**THE LOGAN CONSTRUCTION COMPANY**  
Chillicothe, Ohio

# AUSTIN

The American Favorite  
60 H.P. & 90 H.P.  
Runabouts,  
Touring Cars, Limousines  
Austin Automobile Co.,  
Grand Rapids, Mich.

## Great Western

5-PASSENGER TOURING CAR  
24 H. P. 5 x 7 motor, 104-inch wheel base,  
32 x 3 1-2 Tires.  
Write us for new Catalogue  
**Model Automobile Co., Peru, Ind.**

## THE MARMON

"A Mechanical Masterpiece"  
The Easiest Riding Car in the World  
BUILT BY  
**NORDYKE & MARMON CO.**  
Established 1851 INDIANAPOLIS, IND.  
Write for Catalog.

THE TRUTH ABOUT THE AUTOMOBILE  
And What It Costs to Maintain One  
A 64-page booklet containing sworn state-  
ments of 158 users of the  
**SINGLE CYLINDER CADILLAC**  
showing actual cost of maintaining their cars.  
It also contains much advice of value to the  
automobile buyer.  
Ask for free copy of Booklet No. 7.  
Cadillac Motor Car Company, Detroit, Mich.

## HAYNES

ALWAYS HAS A PERFECT SCORE  
**HAYNES AUTOMOBILE COMPANY**  
KOKOMO, IND.  
Oldest Automobile Manufacturers in America  
Members A. L. A. M.  
New York, 1715 B'way Chicago, 1702 Mich. Ave.

**SHOW ME** a Mitchell. 'Phone "that" to  
any Mitchell agent and he'll  
take you out if you're in-  
terested in the best value for  
money outlay you ever saw in the auto-  
mobile line. Mitchell cars sell themselves.  
Prove it. Ask for catalogue 18.  
**MITCHELL MOTOR CAR CO.**  
308 Mitchell St., RACINE, WIS.

## CAMERON

All models 16-20 H. P. Three forward speeds  
WRITE FOR CATALOG!  
2 Passenger \$850.  
3 " \$935.  
4 " \$1050.  
4 " \$1100.  
**Cameron Car Co., Beverly, Mass.**



Assemble  
your  
6 cylinder  
car.  
Write for cir-  
cular  
**HOWARD MOTOR WORKS, Yonkers, N.Y.**

The Automobile of **MONARCHS**  
**The MONARCH of Automobiles**  
**THE MONARCH MOTOR CAR CO.**  
Chicago Heights - Illinois



Write for booklet about the  
**OAKLAND,**  
the lightest car of its power and  
capacity on the market.  
**Oakland Motor Car Co.,**  
PONTIAC, MICH.

ASK US ABOUT  
**Continental**  
**Ready-Flated Tires**  
They reduce tire expense  
CONTINENTAL CAOUTCHOUC COMPANY  
1788-1790 Broadway, Cor. 58th St., New York City  
"Keep Your Eye on Continentals."

**HERZ'S**  
**"PATER NOSTER"**  
The Best SHOCK ABSORBER Made

**PALMER SINGER**  
**PALMER MFG. & SINGER CO.**  
1620-22-24 Broadway, New York. 1321 Michigan Avenue, Chicago, Ill.

Why Have Tire Trouble?  
Ride with pleasure and assurance  
Write us for particulars on our  
**PUNCTURE PROOF PROTECTOR**  
**EMPIRE STATE TIRE CO.**  
198 Terrace BUFFALO, N.Y.

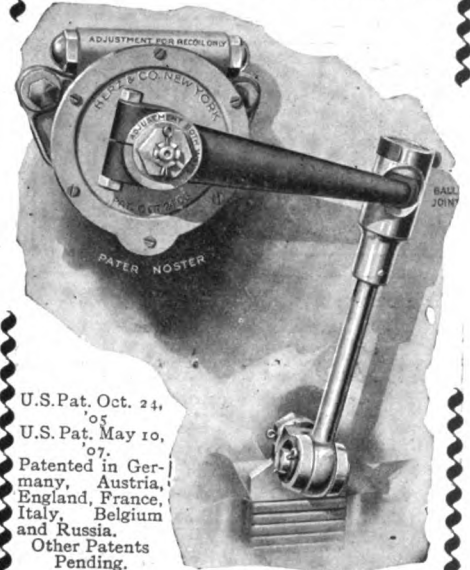

U.S. Pat. Oct. 24, '05  
U.S. Pat. May 10, '07.  
Patented in Germany, Austria, England, France, Italy, Belgium and Russia.  
Other Patents Pending.

Used as regular equipment on the best makes of European cars.  
Specify the "P. N." on the car you order.  
No leather. All hardened and ground steel brakes moving in oil bath.  
Ball joints, allowing full side swing.  
Total absence of all shocks and vibrations on the roughest roads.  
A wonderful preserver for tires and machinery. Makes riding a luxurious pleasure.  
Set of four, complete with attachments, \$75.00  
Set of two, complete with attachments, 40.00  
Ask your dealer or write us.

**PIERCE-RACINE**  
1908 MODELS  
40 H. P., 4 Cyl. Model D, \$3,000  
30 H. P., 4 Cyl. Model E, \$2,000  
**PIERCE ENGINE CO., Racine Wis.**

**"Firestone"**  
**PNEUMATIC TIRES**  
For all Standard Rims  
**Firestone Tire & Rubber Co.**  
Akron, Ohio

**Pullman**  
**AUTOMOBILES**  
Fair Priced. Unexcelled Value.  
**YORK MOTOR CAR COMPANY, York, Pa.**

**"FILLEM"** A special compound of self-vulcanizing rubber for repairing cuts, punctures, curb injuries and sand blisters. A repair can be made in one minute and executed as effectively as though performed by an expert repair man. Protection to your tires for a season. Price \$2.50.  
**Greenwald Rubber Co., 32 Church St., Buffalo, N. Y.**

The best that can be built  
  
**THE SPEEDWELL MOTOR CAR CO.**  
DAYTON, OHIO

**HEALY RAPID REMOVABLE RIM**  
The lightest and simplest Removable Rim, but so strong it is guaranteed to stand the hardest driving in racing or touring car. Costs \$60 equipped, with extra Rim and Wrench. Get our Special Guarantee.  
**Healy Leather Tire Co., 88-90 Gold St., New York 1906 B'way, N. Y. 1351 Michigan Ave., Chicago**  
WRITE TODAY FOR BOOKLET.

**THE HERZ-TIMER**  
Has Stood the Test of Time  
THE BEST CIRCUIT-BREAKER MADE. STANDARD OF EUROPE AND AMERICA. OVER 100,000 IN CONSTANT USE. SAVES 30% IN GASOLINE and CURRENT.



Tool-Makers' Work Throughout  
It's Tool-Steel vs. Tool-Steel

20 Different Types to Suit Any Make of Motor. (State Make of Motor When Ordering.) It Costs You Nothing to Have Your Dealer Demonstrate It.  
BEWARE OF WORTHLESS IMITATIONS  
**HERZ & CO. CIVIL ENGINEERS**  
203 LAFAYETTE ST., NEW YORK  
PARIS VIENNA  
Write for our "Gold Book"—it's free.

**Stearns** SEND FOR CATALOG  
**F. B. Stearns Co.**  
2970 Euclid Avenue,  
**CLEVELAND, OHIO.** 30-60 horse-power

COMPLETE WITH TOP  
**Wayne** \$2500  
NOTHING TO BUY BUT A LICENSE

  
\$250 Original Motor Buggy  
\$400 for 12 H.P. Top \$25 extra  
Over 400 in use. Invented by an engineer after 10 yrs. labor in auto work. Speed 4 to 40 miles per hour. 50 to 100 miles on one gallon of gasoline. Will climb steep hills and run in mud and sand. Guaranteed for one year. Write for catalogue, testimonial letters, etc.  
**Success Auto Buggy Mfg. Co. (Incorporated)**  
528 De Baliviere Ave., St. Louis, Mo.

**Rainier**  
1908 Model D, 50 H. P.  
NEW FACTORY  
**SAGINAW, MICH.**  
COMPLETE CATALOGUE NOW READY  
**RAINIER MOTOR CAR COMPANY**  
Broadway, cor. 56th St., New York

MANUFACTURER TO CONSUMER  
**1907 CAR**  
30 H.P., Price, \$1,850  
Send for Catalogue  
**TREBERT GAS ENGINE CO.**  
35 FORD STREET ROCHESTER, N. Y.



**ALUMINUM  
BRASS AND BRONZE  
AUTOMOBILE CASTINGS**  
Satisfaction Guaranteed  
American Brass and Aluminum Works  
Indianapolis, Ind.

**Auto-Parts to Blue Print**  
ACCURATELY—SATISFACTION  
Difficult Stamping and Drawing  
OTTO KONIGSLOW MFG. CO.  
CLEVELAND, OHIO

You can run your motor at **SLOWER  
SPEED** with an  
**EISEMANN**  
than with any other  
**MAGNETO**  
LAVLETTE & CO., 112 W. 42nd St., New York

Special Drop Forgings in Quantities  
Chrome Nickel and all Special Steels  
Oil Treating and Annealing  
The Canton Drop Forging and Mfg. Co.  
CANTON, O., U. S. A.

**ALUMINUM CASTINGS**  
Harroun Auto Bumper  
Martin Fuel Strainer  
AND SPECIAL WORK TO ORDER  
Manufacturers  
THE TURNER BRASS WORKS  
59 Park Avenue SYCAMORE, ILL.

**HESS-BRIGHT  
BALL BEARINGS DWF**  
AMERICAN 21st and Fairmount Ave. EUROPEAN  
PHILADELPHIA, PA.

**Drive Chains  
—AND—  
Sprockets**  
of all kinds for  
**Automobiles**  
Baldwin Chain & Mfg. Co. Worcester, Mass.

ASK  
**RAPID—PACKARD  
GRABOWSKY—PUNGS**  
about  
**INDESTRUCTIBLE  
STEEL WHEELS**  
1224 Michigan Avenue, Chicago

**Automobile Gears**  
  
*If in a hurry, write us*  
**R. D. Nuttall Company**  
Pittsburg, Pa.

**DROP FORGINGS**  
FOR **AUTOMOBILE AND  
MACHINERY MANUFACTURERS**  
  
*WE ALSO MANUFACTURE  
STEAM HAMMER FORGED*  
**HIGH GRADE CRANK SHAFTS**  
EITHER ROUGH FORGINGS,  
OR COMPLETELY MACHINED.  
**ANDERSON FORGE & MACHINE CO.**  
No. 18 STAUBIN AVE.  
DETROIT, MICH.

  
**Peugeot Chains—"Strongest in the World."**  
296 Broadway, New York

**QURIDE**  
(REGISTERED)  
**FILLED GEARS**  
ARE SILENT RUNNING  
Let us tell you more about "QURIDE"  
Picrome Hide Co., Syracuse, N. Y.

We will not accept your contract  
unless we can give you the delivery  
you require. We will not accept more  
contracts than we can fill with proper  
attention to each. We make pressed  
steel frames and automobile stampings  
**The Hydraulic Pressed Steel Co.**  
Cleveland, Ohio

The "Victor" Lock Nut  
Manufactured by  
**WALKER BROS. CO.**  
218 Walton Street, Syracuse, N. Y.

**PARISH & BINGHAM**  
PRESSED STEEL  
**FRAMES  
ARE STANDARD**  
WRITE FOR ESTIMATES  
CLEVELAND, - OHIO

**IMMEDIATE DELIVERIES SLIDING GEAR  
TRANSMISSIONS**  
Suitable for 20-24 H. P. Car  
WE CAN FILL ORDERS FOR ONE  
OR ONE HUNDRED PROMPTLY  
**ECLIPSE MACHINE CO.**  
ELMIRA, N. Y.

**ALUMINUM  
PHOSPHOR BRONZE and BRASS  
CASTINGS**  
FOR AUTOMOBILE WORK  
PIONEER BRASS WKS., INDIANAPOLIS, IND.

**Spicer Universal Joints**  
*Dust Proof—Oil Tight*  
**SPICER UNIVERSAL JOINT MFG. CO.**  
7 Madison Avenue  
PLAINFIELD, N. J.

**THE REEVES AUTO ENGINES**  
AIR AND WATER COOLED  
Three Models for Early Delivery  
—ALSO—  
COMPLETE CHASSIS AND PARTS  
FOR HIGH WHEEL AUTO BUGGY  
**REEVES PULLEY CO.** COLUMBUS INDIANA

**DIAMOND**  
drive their cars more miles  
per dollar cost than any others  
**CHAINS**  
TRADE MARK  
DIAMOND CHAIN & MFG CO.  
230 W. Georgia St., INDIANAPOLIS, IND.

**Smith**  
**English Speed Indicators**  
Sold singly or in combinations with  
clocks, communicators, etc.  
**S. SMITH & SON, Ltd.**  
116 Broad Street New York

# HARRIS OILS

For Gasoline Motors  
Made in three grades

LIGHT  
MEDIUM  
HEAVY

One of these grades is best adapted to your motor

Strang, driving the Isotta Car, winner of Briarcliff race, used the Medium grade. Just as desirable for the everyday motorist

**HARRIS OILS**  
are superior because they afford better lubrication; no cylinder deposits

FOR SALE BY ALL GARAGES AND SUPPLY HOUSES

A. W. Harris Oil Co.  
324 South Water Street,  
PROVIDENCE, R. I.



THE TIRE  
OF  
QUALITY

THE TIRE  
FOR  
SERVICE

This 1908 "G & J" Tire has run  
**4516 MILES**

and shows practically no sign of wear. Do you want this kind of Tire Service? —then have your car equipped with

## G & J TIRES

Send for Catalogue and Prices  
**G & J TIRE CO., Indianapolis**  
New York—10 W. Sixtieth St.  
Chicago—1434 Michigan Ave.  
San Francisco—414-416 Van Ness Ave.  
Detroit—256 Jefferson Ave.  
Denver, Colo.—1541 Cleveland Place.  
Buffalo—912 Main St.  
Philadelphia—713 N. Broad St.  
Los Angeles, Cal.—1010 S. Main St.  
Minneapolis, Minn.—21 S. Second St.  
Omaha, Neb.—11th and Farnum St.  
Pittsburg, Pa.—830 Liberty Ave.  
Atlanta, Ga.—35 N. Pryor St.  
Memphis, Tenn.—181 Madison St.  
St. Louis, Mo.—415 N. Fourth St.  
Boston—110 Federal St.  
Portland, Ore.—326 Burnside St.  
Kansas City, Mo.—1607 Grande Ave.  
Cleveland, O.—326 Frankfort Ave., N. W.

# X.L.C.R. Magneto Plug

Can not Foul, Burn Out or Short Circuit

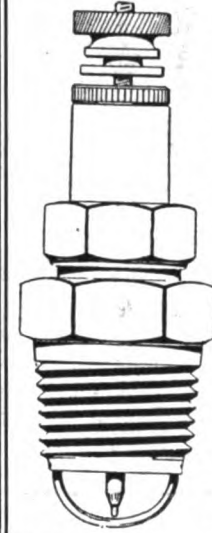

Genuine platinum tip, nickel-ground terminal, adjustable spark gap and other valuable features.

**THEY MAKE GOOD OR YOU DON'T PAY FOR THEM.**

From one to four, no more, sent by mail

prepaid to any address on receipt of \$1.00 each.

Try them 10 days and then if not absolutely satisfactory return them and we will refund at once.

**Excelsior Auto Supply Co.**  
1432-1434 Michigan Avenue  
**Chicago**

## Auto Running Gears



With chain or shaft drive axles, any wheel base and any height of wheels.

Write for our new Catalog

ALSO ALL KINDS OF BODIES



Borbein Auto Co., 2109 N. 9th St. St. Louis, Mo.

## The Springfield Tire Tool

For removing Tires, any size from 3 to 5 inches.  
PRICE, \$1.00, Express prepaid.



## The Springfield Plug Wrench

Will fit any of the standard Plugs now in use.  
PRICE \$1.00 Express Prepaid

**THE SHAWVER CO.,** SPRINGFIELD, OHIO

A Spark Plug lasts only as long as its weakest part. The plug that is made to "stay right the longest" is the

THERE'S  
A SPECIAL  
"STA-RITE"  
PLUG  
FOR EVERY  
PURPOSE



Because the porcelain is protected—the large air space prevents cracking—the milled steel shell insures greatest durability. The simplest, strongest plug made. Simply can't leak. Biggest trouble-saver.

**\$1** Of any Dealer or Direct The "Gotham" STA-RITE at \$1.00 is equal to any \$1.50 plug in the world. Outlasts two ordinary plugs

**THE R. E. HARDY COMPANY**  
25 West 42d St., New York

## McCord FORCE FEED LUBRICATOR

"The Mark of a Good Motor Car"

RADIATORS • CARBURETERS  
MCKIM  
COPPER - ASBESTOS GASKETS

**McCord & Company**  
1404-1408 Old Colony Bldg., Chicago  
N. Y. Office: Hudson Terminal, 50 Church St.



**CORCORAN**

CINCINNATI, OHIO.

No. 22

Auto Lamps  
of all Descriptions

## THE SELDEN CAR

Five Passenger Touring Car \$2,000  
Three Passenger Runabout \$2,000

AN ATTRACTIVE  
CAR AT AN AT-  
TRACTIVE PRICE

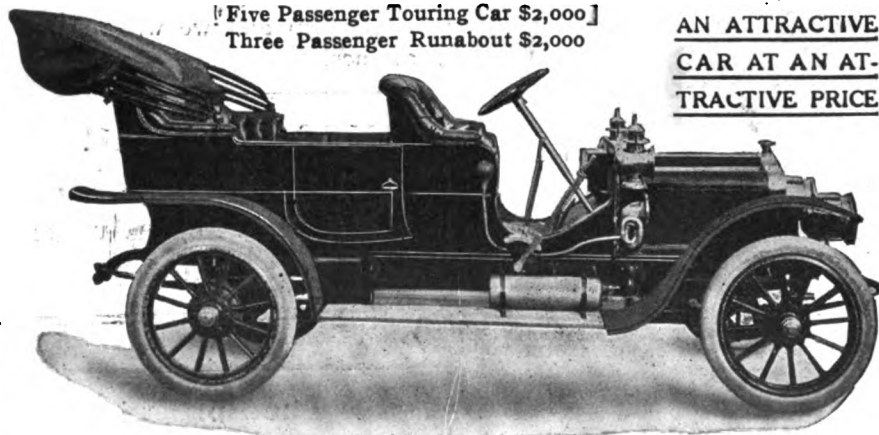

MODEL 28

**SPECIFICATIONS:** Engine—4 cylinders, 4 1/2 x 4 1/2—28-30 brake horse-power. Transmission—3 speeds forward and reverse, selective, Timken bearings. Wheel base—109 inches; tread, standard; clutch, cone leather. Body—sheet metal, straight line type, roomy and comfortable. Tires—3 1/2 x 3 1/2, quick detachable; make optional. Frame—pressed steel, 4 1/2 inches deep. Front axle—single I-beam drop forging, ball bearings. Rear axle—Beval gear drive, enclosed type, roller bearings. Ignition—synchronised jump spark. Weight—empty, 2,500 lbs. (actual, not catalog.)

**SELDEN MOTOR VEHICLE CO., ROCHESTER, N. Y.**

Members A. L. A. M. Agencies Wanted in Unoccupied Territory

Represented in Greater New York by

**The Palmer & Singer Manufacturing Co.**

1620 BROADWAY

## Auto Pump Oiler

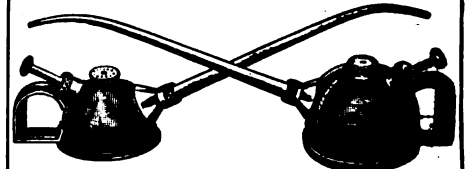

The only pump oiler on the market designed for automobile oiling. Pumps the oil to the bearings in just the quantity desired. Spouts from 3-inch to 9-inch and all interchangeable

For Sale by All Leading Jobbers

**MAPLE CITY MFG. CO.**  
Monmouth, Ill.

## "Rich" Spark Plugs



ARE BEST

ASK FOR CIRCULAR

\$1 Prepaid. Discount to Dealers.

**Richardson Engineering Co.**  
Hartford, 50 Ford Street Conn.

**"Continental Motors are Standard"**

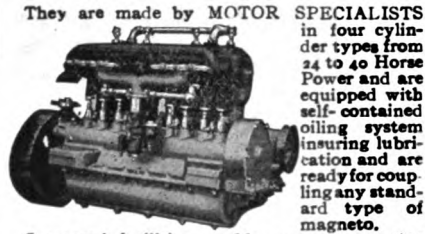

They are made by MOTOR SPECIALISTS in four cylinder types from 24 to 40 Horse Power and are equipped with self-contained oiling system insuring lubrication and are ready for coupling any standard type of magneto.

Increased facilities enable us to guarantee quality and deliveries. Also clutches and transmissions. Send for catalogue.

**CONTINENTAL MOTOR MFG. CO.**  
MUSKOGON, MICH.  
K. Franklin Peterson, Western Representative, 166 East Lake Street, Chicago, Ill.  
Thos. J. Wetzel, Eastern Representative, 29 West 42d Street, New York, N. Y.

**THE FRENCH MFG. CO.**

132 ROBBINS ST  
WATERBURY, CONN.  
Manufacturers of  
**SEAMLESS TUBING**  
Thin Gauges  
Small Sizes  
Brass, Copper, Bronze and White Metal  
**SPECIALTIES:**  
Irregular Shapes, Solid Drawn Work and Hydro-Carbon Lighting Tubing

**SAMSON** TYPE COURSE RUBBER TUBES  
MADE IN FRANCE  
**KING OF TIRES**  
**TIRE OF KINGS**  
SAMSON LEATHER TIRE CO.,  
1634 to 1642 BROADWAY  
G. de PONTAC  
Gen. Mgr. NEW YORK CITY



**Here's the Stuff**

Dixon's Motor Graphite helps compression in cylinders, quiets noise in gears, makes smooth running throughout. Booklet G tells

how to use it. Write for free copy.  
**JOSEPH DIXON CRUCIBLE CO.**  
JERSEY CITY, N. J.

**NOTICE**

Having cautioned both trade and public at various times against making, selling or buying tire covers and spare tire holders that infringe our patented Gilbert Tire Covers and Gilbert Spare Tire Holders, we are now compelled to protect our interests regardless of the unpleasant results to those who have not heeded our warnings.

We have retained a prominent law firm who make a specialty of this work, and they have taken this matter entirely off our hands. Suits will be brought against those who are using, have in stock, offer for sale, or make articles that infringe our patented goods.

**THE GILBERT MFG. CO.**  
NEW HAVEN, CONN.

**NOW READY for IMMEDIATE DELIVERY**

**BOWERS JR. CARBURETER**

High Grade Material and Construction Throughout

**\$10 BOWERS JR.**

The **BOWERS Jr. CARBURETER** while listing at the low price of only \$10, is in every respect a high grade instrument, perfect in workmanship and finish and with the exception of the regular **BOWERS CARBURETER** will produce a higher efficiency, greater flexibility and economy than any carbureter now on the market. Simple—durable—has but one adjustment, being perfectly automatic in operation and absolutely reliable. Gives a perfectly proportioned mixture for various auto speeds. Let us send you full particulars—they will interest you. Write to-day.

**The F. E. BOWERS COMPANY, Inc.,**  
NEW HAVEN, CONN.  
AGENCIES:

Made in 2 Sizes:  
1", price, \$10.  
1 1/4", price, \$10.

NEW YORK, A. H. Green & Co., 16-17 Broadway; BOSTON, Post & Lester Co.; HARTFORD, Post & Lester Co.; PHILADELPHIA, Philadelphia Motor Car Co.; ST. LOUIS, Eichen-Faught Co.; BUFFALO, Centaur Motor Co.; PITTSBURG, PA., Kauffman Bros.; CHICAGO, Eugene Arnstein; ST. PAUL, C. J. Smith Co.; PORTLAND, ORE., Fallou & Wright; SAN FRANCISCO, Hughson & Merton, Inc.; LOS ANGELES, Hughson & Merton. PORTLAND, MAINE, The James Failey Co.



We Are Now Booking  
**1908 Orders**

Limousine  
 Landalette  
 Touring Car  
 Runabout  
 Racing

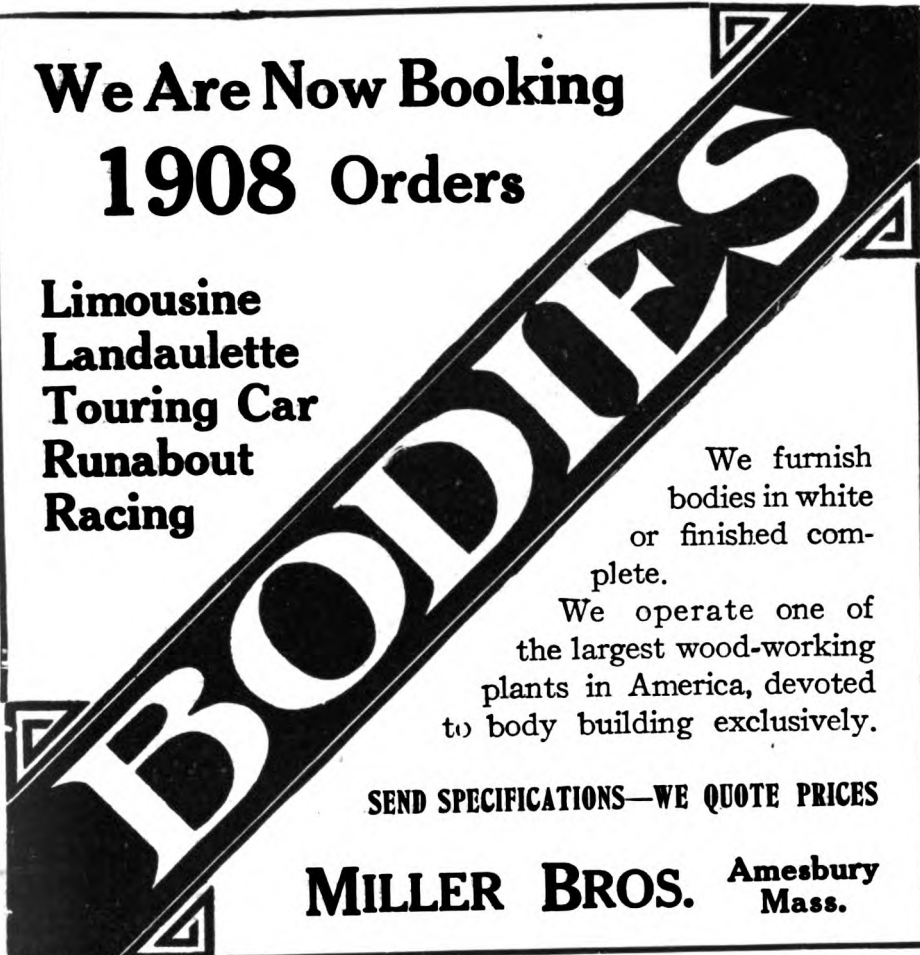

We furnish bodies in white or finished complete.

We operate one of the largest wood-working plants in America, devoted to body building exclusively.

SEND SPECIFICATIONS—WE QUOTE PRICES

**MILLER BROS.** Amesbury Mass.

# AUTOGAS

SUPPLIES LIGHT TO ANY  
 AUTOMOBILE LAMP

LASTS FOR MONTHS

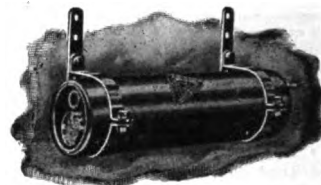

IT GIVES TWICE THE SERVICE OF  
 ANY OTHER GAS TANK. WRITE US

**Avery Portable Lighting  
 Company**

MILWAUKEE, WIS.  
 NEW YORK OFFICE: 51 W. 63d Street

## THE SPENCER POWER AIR PUMP

Inflates Largest Tires  
 in Less Than Two  
 Minutes.

The Motor  
 Does the Work

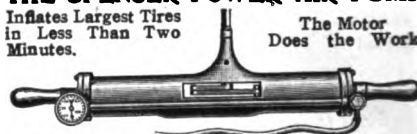

THE AUTO PUMP CO.  
 Write for circular. 14 Main St., Springville, N. Y.

“The Lungs of the Motor”

# DUPLEX

## Carburetor

Constructed on scientific principles to incorporate extreme simplicity and highest efficiency.

No springs; no auxiliary valve; no flooding; no leakage; no power restriction; no priming.

Positively adapted to any engine.

Built by skilled mechanics and thoroughly tested in actual service under all conditions.

Not mere advertising statements, but FACTS fully guaranteed.

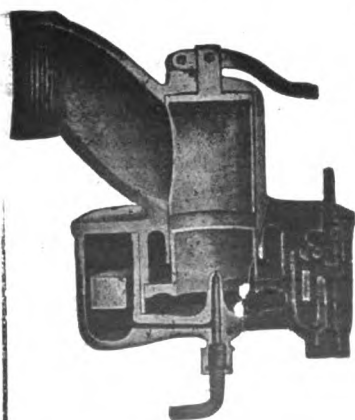

One Adjustment  
 One Throttle  
 Perfect Control

THE  
 “DUPLEX”  
 COMPANY

Belfast, Maine, U.S.A.

Designers, Pattern Makers,  
 Iron, Brass and Bronze  
 Founders, Machinists, and  
 BUILDERS of HIGH  
 SPEED MOTOR BOATS

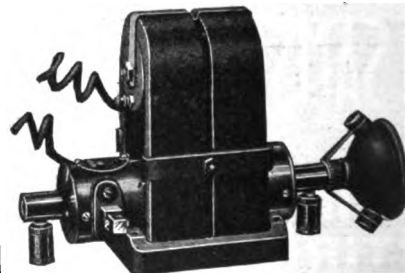

## FORD-MAXWELL SPECIAL MAGNETO

FOR

Fords, Models N, R and S  
 Maxwells, Models D, L,  
 N and H

Gives more speed. No battery trouble or expense. Brackets and bolts furnished for installing. Anyone can install in 15 minutes. Works with any standard coil. No expensive special outfit or coil required. Absolutely cannot injure your coil. Equipped with positive acting governor.

**Hercules Electric Co.**  
 Indianapolis, Ind.

Which is it? Ford or Maxwell?

## Jencick Motors

Suitable for Pleasure Cars and Heavy Duty Trucks, where reliability and efficiency are wanted.

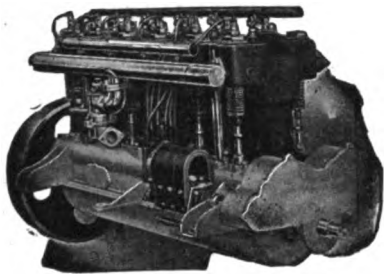

H.P. 12 to 70, 2-4 and 6 cylinder, watercooled, four cycle, make and break and jump spark. Krupp chrome nickel steel. Parsons' manganese bronze base. Hess & Bright ball-bearings—simplicity of design and experienced workmanship. These are some of the Jencick features.

MOTORS BUILT BY NONE BUT SKILLED LABOR and the above mentioned materials, will have everlasting efficiency and durability. We will be pleased to mail catalogue on request.

**JENCICK MOTOR MFG. CO.**  
Port Chester, N. Y.

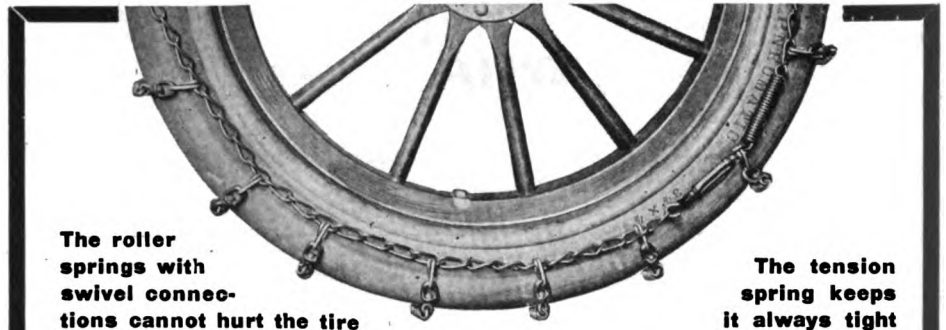

The roller springs with swivel connections cannot hurt the tire

The tension spring keeps it always tight

# VICTOR ANTI-SKIDS

with roller spring grips are the only ones that cannot hurt the tires. All others wear sharp on the edges and cut away the rubber. The revolving Victor roller always remains round. We absolutely GUARANTEE our agents and customers from loss through **alleged infringements**. See the Victor before you buy or send to us for catalog and prices. It pays to get the best; we are sure we have it.

MANUFACTURED BY

**VICTOR TIRE TRACTION CO., Nashua, N. H.**

Excelsior Supply Co., Western Distributors, Chicago, Ill. W. J. Connell, New England Sales Agent, Boston, Mass.

TRADE MARK

STITCH-IN-TIME VULCANIZER CO.

ANYBODY CAN USE ONE

Electric, Gas or Gasoline Heated.

Mend your own casings and inner tubes with our Vulcanizers.

Booklet on tires and tire repairing for the asking. Let us tell you how to do it. Sold on Guarantee.

TOPEKA KANSAS UNITED STATES

WHEN WRITING TO ADVERTISERS PLEASE MENTION THE AUTOMOBILE

The Best of EVERYTHING for EVERYBODY

That Ever Drives a Motor Machine

WRITE FOR CATALOGUE 70

**EXCELSIOR SUPPLY COMPANY**

Established 1876

233-235-237 Randolph Street CHICAGO

OWNERS WILL GET MAXIMUM COIL EFFICIENCY

SPECIFY



WRITE US If your dealer does not carry them.

**HEINZE ELECTRIC CO.**

LOWELL, MASS.

Makers of High-Grade

Coils and Electric Ignition Apparatus of Every Kind

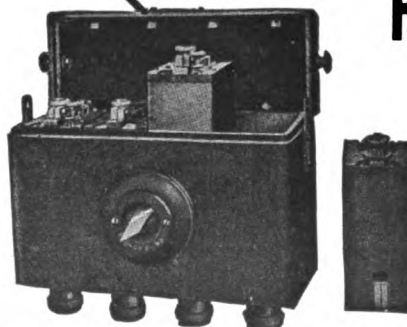

Type B. 35 4-Cyl. Interchangeable Unit Spark Coil

# Col. Sprague's Auto Tops and Fronts

are made expressly for those who want the best there is

☐ A top that will keep its shape until the car is worn out.

☐ A front that is strong, safe and sure, easy to handle, and the only piano finished front made.

Ask for our Catalogue and Price List

**The Sprague Umbrella Co.**  
Norwalk, Ohio

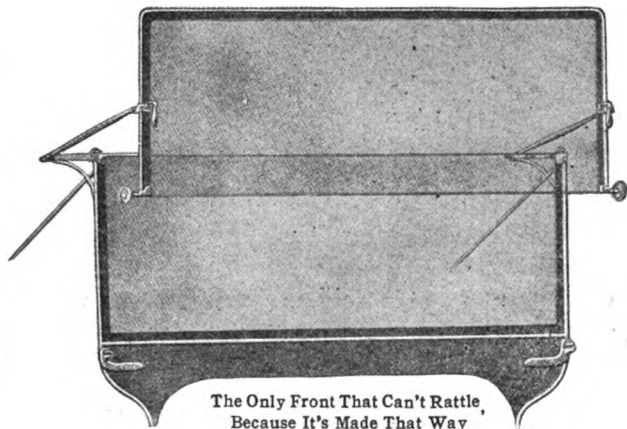

The Only Front That Can't Rattle,  
Because It's Made That Way

**WELDING BY ELECTRICITY**  
INSURES  
STRENGTH, ACCURACY AND DEPENDENCE  
THE STANDARD WELDING CO. CLEVELAND.

4 CYCLE MOTORS

**The "COMPRESSOMETER" tells where**

419 E. WATER STREET

THE BROWN CO.

2 CYCLE MOTORS

SYRACUSE, N. Y.



\$550.  
Top, \$30 Extra.

**P. M. C. \$550 RUNABOUT** SOLID TIRES

Low first cost. Little expense to maintain. 12 H.P. opposed air-cooled motor. Planetary gear. Positive chain drive. Brakes on rear hubs. Standard construction. Complication eliminated. Great hill climber. Ideal for pleasure or business. Information upon request. Immediate delivery.

NO TIRE TROUBLES

C. S. PEETS MANUFACTURING CO., 60 West Forty-third Street, NEW YORK



## The Practical Gas Engineer

What It Is and How To Do It. A book of 150 pages neatly bound in cloth. Sent post-paid for \$1. Address Book Department, The Automobile, Flatiron Building, New York.



**RADIO STORAGE BATTERY**

NO matter how good a battery you now use, here is a better one, the one you will eventually use if you want the best. It guarantees more power and longer life—produces an intense spark like an electric flame.

**AGENTS WANTED**  
Liberal Terms to Right Parties

NO leaking—no slopping or dead cells—no screws or exposed metal parts to corrode—no loss of current by short circuits either between cells or through cases, insuring full capacity of the battery. Covered by written guarantee. Full particulars on request.

**RADIO BATTERY CO.,**  
Thomas S. Witherbee, Gen'l Mgr.  
433 WEST 42d STREET, NEW YORK



**MOTOR PARTS**  
 F. W. SPACKE MACHINE CO.  
 Indianapolis, Ind.

Which we can manufacture *Better and Cheaper*: Pistons, Piston Rings, Connecting Rods, Mitre Gears, Die Casted Bearing *Bushings*. We solicit your *Blue Prints and Specifications*.

**WAUKESHA MOTORS**  
 WAUKESHA MOTOR CO.,  
 Waukesha, Wis., U. S. A.

have demonstrated their smooth quiet, speedy and powerful action satisfactorily to their 1907 users. We can take on a few more contracts for 1908 delivery and will guarantee to deliver whatever we contract for. The self-contained oiling system is a feature of our 4 1/2" x 5" and 4 1/4" x 5" which is well worth looking into.

**THIS MOP-YARN TOP OUTLASTS SIX SPONGES**  
 Will wash sideways, between spokes and under fenders

Price \$1.75 Del'd  
 Extra Top 50c. Del'd



Pat. app. for

**"Perfect" Auto Washer**  
 Manufactured by  
**Long & Mann Company**  
 521 Graves Street ROCHESTER, N. Y.  
 Also "L. & M." Tire Looseners, Lifters and Adjusters, and "Minute" Tire Adjusters

**SUPPLEMENTARY SPIRAL SPRINGS**



the greatest device in the world for saving your automobile. Applicable to all cars—efficient on all. The only practical cure for hard riding cars, relieving the body of all injurious shocks, jolts and jars. No more broken side springs. Fully patented and fully guaranteed. They will save their cost many times in a year and will add **NEW LUXURY, NEW LIFE, NEW SPEED, NEW COMFORT.**  
 THE PRICE—is about one-half that asked for complicated devices that at best can produce temporary results only. Write for full information and prices. - BEWARE OF IMITATIONS.

**SUPPLEMENTARY SPIRAL SPRING CO.,** 4529 Delmar Ave., ST. LOUIS, MO., New York Motor Mart Building.  
 Branches: New York, Motor Mart Bldg., 1876 Broadway. Chicago, 1218-20 Michigan Ave.  
 Boston, 880 Boylston St. Pacific Coast, Los Angeles, San Francisco.



**LOCKE & COMPANY AUTOMOBILE BODIES**

218-220 WEST 84th ST., NEW YORK

WITHOUT PARALLEL IN THIS COUNTRY OR ABROAD  
 COMBINE EXTREME ELEGANCE, MOST REFINED DESIGNS AND UNEXCALLED DURABILITY

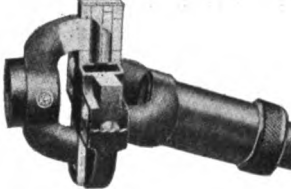

**K-B Pin Joint** No Bolts, Screws or Rivets used in its construction.  
 All Working Parts **HARDENED**

MANUFACTURED BY  
**THE KINSLER-BENNETT CO., HARTFORD, CONN.**  
 American Distributing Co., Sales Agents, 610 American Trust Building, Cleveland, Ohio



**Two Spot** ONE SPARK BEING GOOD TWO MUST BE BETTER  
**Two Spot** IMPOSSIBLE TO SHORT CIRCUIT

The only plug with two distinct, positive and simultaneous sparks inside the cylinder insuring an intensified spark. Quick and positive ignition. Complete combustion **ABSOLUTELY MORE POWER.** Less consumption of fuel and electricity  
 Price, by mail, postage prepaid, \$1.25

**TWO SPOT MFG. CO., 11 CENTER STREET, CANASTOTA, N. Y.**

**"WHITNEY" CHAINS**



**SCHUG SPARK COILS**

No matter how good a coil you now use here is a **BETTER one**  
 It is the standard of spark coil excellence—a high speed vibrator coil giving an extra hot spark; well insulated, silk wound, moisture proof from special insulating compound. Vibrator removable without changing adjustment. A coil for every type, size, and style of gasoline motors. A letter of inquiry carries no obligation—write to us for full information—write today.

**SCHUG ELECTRIC MFG. CO., 325 Jefferson Avenue, DETROIT, MICHIGAN**



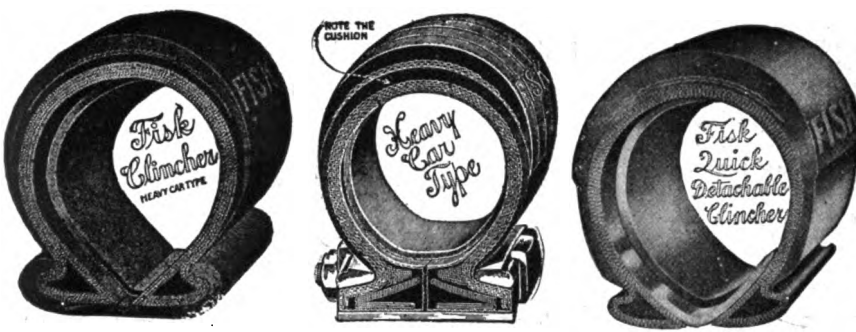

For Regular Clincher Rims. **ALL "FISK QUALITY," HEAVY CAR TYPE** For Standard Q. D. Rims.

**THE FISK RUBBER COMPANY**  
CHICOPEE FALLS, MASS.

The Bolted-On Fisk Tire that is "Fast Everyway" is the ideal equipment; but you can have tires for any rims and tubes for any tires made the Fisk way. Fisk Service can be had at Fisk branches in eighteen cities.



**THE MOST DESIRABLE SPEED-METER**  
COMBINING  
**Best Quality Greatest Efficiency and Lowest Cost**

Accurate and Dependable Always  
This little instrument will fulfill your expectations and desires in a speed-meter. Year after year it has demonstrated this on hundreds of the best cars all over this country. Made of the finest selected materials, and finished in the highest class style, it excels in every comparative test with instruments of a similar construction. Speed-hand Always Steady. Index Plain and Readable.

**GUARANTEED**  
"A Perfect Instrument or your money back"  
Prices, 60 Miles \$40; 100 Miles \$60

**MOTOR CAR SPECIALTY CO.**  
TRENTON, N. J.



Just to Satisfy Yourself

that the **SPLITDORF Common Sense Plug**

is a mighty good plug, use one in your engine. You will find it gives you better ignition than any other Plug. Price, \$1.25.

**C. F. SPLITDORF**, Walton Ave. & 138th St. New York, Branch 1679 Broadway.

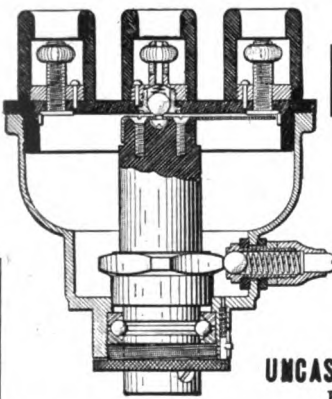

**LEAVITT DISTRIBUTOR**

is built right and gets maximum results regardless of conditions. Its construction gives durability.

All aluminum body.  
Rubber top.  
Water and heat proof.  
Sizes 2 to 8-cyl. (inclusive). Write for catalog.

**UNCAS SPECIALTY CO., Norwich, Conn.**  
High Grade Ignition Specialties



**THERE IS A REASON**

With the same radius, frictional area and spring pressure, the **Hele-Shaw Clutch** is three times as powerful as any flat plate clutch made. Therefore, with the same radius and frictional area and one-third the spring pressure, the Hele-Shaw Clutch will transmit as much power as any flat plate clutch. Hence, it is more flexible, softer in engagement, less liable to heat, less subject to wear. It is no experiment—there are 12,000 in operation in Europe.

Specify the Hele-Shaw Clutch for the car that you buy. It can be easily fitted. Your dealer will readily comply this year to make the sale. Write for particulars.

**MERCHANT & EVANS CO.**  
Philadelphia New York Chicago Baltimore Kansas City Denver

**INSIST UPON A RADIATOR EASILY REPAIRED**



**LONG'S RADIATORS**

are the only ones on the market that can be repaired when an accident is met with. Any broken tubes can be replaced with new ones at a small expense. Other makes of radiators when damaged must be entirely replaced at a heavy expense.

**LONG DISTANCE**  
**LONG MANUFACTURING CO., Chicago, Ill.**

Send for Catalogue.



**SWINEHART Dependable Tires**

Never puncture or come off. Contain best grade of rubber obtainable; properly cured to give **AMPLE RESILIENCY** and years of service.



Tool for applying free

Write for Catalog C and users' opinions  
**The Swinehart Clincher Tire and Rubber Co.**  
AKRON, OHIO

New York 875 7th Ave. Chicago 1231 Michigan Ave.

TRADE MARK

# Raybestos

## BRAKE LINING

**INDESTRUCTIBLE—NO AMOUNT OF HEAT CAN AFFECT IT**

Composed principally of asbestos woven with wire—is flexible—will not burn out or carbonize under heat—produces more friction than metal against metal. Heat Proof, Oil Proof, Water Proof, Weather Proof and almost Wear Proof.

Widths—1-in., 1½-in., 2-in., 2½-in., 3-in., 4-in.  
 ½ and 5-32 thick

ROYAL EQUIPMENT CO., 155 Neusaleuk Ave., BRIDGEPORT, CONN.  
 Mfrs. of Raymond Brake



## “SPEED” CARBURETER

### Solves the Carbureter problem completely

Positively guaranteed to develop greater power, speed, flexibility and economy in the engine than any carbureter in the world or purchase price refunded.

You run no risk—try it—it will save you a world of trouble and make your cars better and more efficient. Write for full particulars.

**SPEED CHANGING PULLEY CO.** 752 Washington St. Indianapolis, Ind.

Pacific Coast Distributors: T.H. Morgan, 322 Mason Bldg., Los Angeles, Cal.

Canadian Agency: The Canadian Fairbanks Co., Ltd., 444 St. James St., Montreal, Canada.

# NEW PRICE LIST

## DOW

### NON-DEFLATION TUBES

**THE BEST TUBES EVER MANUFACTURED  
 RUN COOLER—ARE RESILIENT AND FAST  
 INSURE EASE OF MIND AND EASE OF POCKET**

### NEW PRICE LIST

In Effect June 15, 1908, Superseding All Others

AMERICAN SIZES		PRICE	METRIC SIZES		PRICE
FOR AMERICAN SIZE CASINGS ONLY.	28 x 3	\$14.00	FOR METRIC SIZE CASINGS ONLY.	860 x 85	\$17.00
	30	15.00		710 x 90	16.00
	32	16.00		760	18.00
	34	17.00		810	18.00
	36	18.00		840	19.00
	28 x 3½	16.00		870	21.00
	30	17.00		910	22.00
	32	18.00		960	22.00
	34	19.00		1010	24.00
	36	21.00		765 x 105	19.00
	30 x 4	19.00		815	21.00
	31	20.00		875	22.00
	32	21.00		915	22.00
	34	22.00		820 x 120	22.00
	36	24.00		850	23.00
	32 x 4½	22.00		880	24.00
34	24.00	920	26.00		
36	26.00	1020	30.00		
34 x 5	26.00	1080	32.00		
36	28.00	895 x 135	26.00		
34 x 5½	28.00	935	28.00		
36	30.00	1000 x 150	36.00		

NOTE.—A discount of five per cent. will be allowed if cash accompanies order; otherwise, these prices are net.

Send for Catalog and Reports of Tests.  
 Dealers—Send for Discounts.

## DOW TIRE COMPANY

2000 BROADWAY, N. Y. 184 SUMMER ST, BOSTON, MASS.

# The RELIABLE JACKS



There is one real test and that is the test of service. Automobilists all over this country have made that test, and are now using “RELIABLE” Jacks. It is not a question of sentiment, or of favoritism. It is a question of superiority. Make the test for yourself and you'll solve your lifting troubles. Sold by best dealers—but insist on the RELIABLE, or write to

**ELITE MFG. CO., Ashland, Ohio**

Discounts to Mfg. Jobbers and Dealers.

## A LIFE SAVER

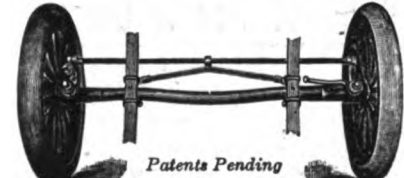

Patents Pending

### THE LITTLE STEERSMAN

The only Automatic Steering and Safety Device. Will guide your car when you lose control. Insures your safety and your car. Easily attached to any auto. Price \$10.00. Satisfaction Guaranteed.

Write for Booklet

**THE ABRAMS-MASON CO. - Chatham, New York**



YOU WANT THE BEST  
 GET A

# HICKS!

Speed Indicator  
 Elgin Watch  
 Veeder Odometer

ALL ON ONE DIAL  
 Size 4x4 inches  
 Price \$60 Complete  
 Fully Guaranteed

SEND FOR BOOKLET

**HICKS SPEED INDICATOR CO.** 1263 Atlantic Avenue BROOKLYN, N. Y.

## The SLAMA TIRE PROTECTOR



LIKE A COAT OF MAIL.

In its flexibility is The Slama Tire Protector. Made of cross-shaped, steel links, case hardened. Protects the tire from punctures and skidding.

Fits any Tire made.  
 Easily attached.  
 Is not fastened to tire, wheel or rim, so cannot injure tire.  
 For smooth or rutty roads.  
 The best Anti Skid made.

Write for new booklet

**Slama Tire Protector Co.**  
 612 East 15th St., Kansas City, Mo.

## OUR BULLETIN A

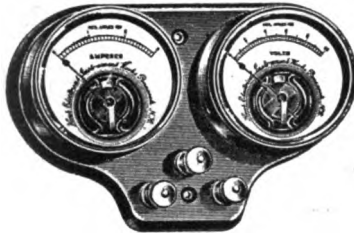

Contains a fund of information regarding-

### Ignition Troubles

Send for copy.

**HOYT ELECTRICAL INSTRUMENT WORKS,**  
PENACOOK, N. H.

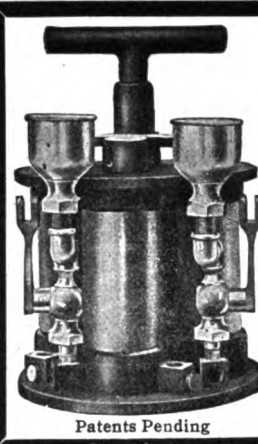

## The RELIABLE SELF STARTER

Positively starts any gasoline motor from seat.

No more cranking. Easily fitted to any motor. Compact. Takes up little space. Small weight. Absolutely positive in action. No possibility of back firing. Nothing to wear out. Always ready for use. Starts motor when cold. Nothing to get out of order. No interference with regular equipment of car. Convenient to use. *Moderate Price.* Sold under positive guarantee. Write for descriptive circular and price.

**BEAMER MFG. CO.,** Detroit, Mich.

Patents Pending

**THE WATER WAY BETWEEN DETROIT AND BUFFALO**

The D. & B. Line Steamers leave Detroit weekdays at 5:00 p. m., Sundays at 4:00 p. m. (central time) and from Buffalo daily at 6:30 p. m. (eastern time) reaching their destination the next morning. Direct connections with early morning trains. Lowest fares and superior service to all points east.

Popular week end excursions to Buffalo and Niagara Falls, leave Detroit every Saturday and return Monday morning.

**RAIL TICKETS AVAILABLE ON STEAMERS**

All classes of tickets sold reading via Michigan Central, Wabash and Grand Trunk railways between Detroit and Buffalo in either direction will be accepted for transportation on D. & B. Line Steamers. Send 2c. stamp for illustrated pamphlet and Great Lakes Map. Address: L. G. LEWIS, Gen'l Pass. Agent, Detroit, Mich.

**DETROIT & BUFFALO STEAMBOAT CO.**  
PHILIP H. McMILLAN VICE-PRES. A. A. SCHANTZ GEN'L MGR.



## WISCONSIN TIRE PROTECTOR

Protectors that Protect

Guaranteed **ABSOLUTELY PUNCTURE PROOF** and that they will **STAY ON THE WHEELS.** They prevent skidding. They preserve the casing. They save tire bills. You commence getting returns from your investment the day you put the Protectors on, as they save the tires. **WE KNOW Wisconsin Protectors are all right and are willing to SHOW YOU.** Send us your order and we will ship the Protectors; you may put them on and run them for ten days, and if not perfectly satisfactory to you, we will refund your money.

**Wisconsin Tire Protector Company**  
1231 Michigan Ave. Chicago, Ill.

## THE RUTENBER LINE

Safest and Surest Line to Use for Travelling



**ALWAYS RELIABLE**  
**1909 MODEL "W" 4x4**  
Fully equipped with self-contained oiling system with Fan and Carburetor attached. The same high grade workmanship and reliability that always distinguishes the

**RUTENBER MOTORS**  
which still hold the World's Record for the 24-hour Endurance Run.  
Rutenber Motors sell the car. Write us and we will prove it.

Full line, from 25 H.P. to 60 H.P.

### RUTENBER CARBURETORS

Best for your car. Economical and reliable. Write for catalog and information  
**THE WESTERN MOTOR COMPANY, Logansport, Ind.**

## Flentje Glycerine Jounce and Recoil Preventer for Automobiles

Invention Perfected March, 1908. Patents Pending.

Is the best in the world. To show my confidence in my invention, I give 60 days on trial and one year's guarantee. I offer \$2000 against \$1000 to any shock absorber manufacturers now on the market who can disprove my statement.

For catalogue and full particulars of the merits of my device, please send to

**ERNST FLENTJE**  
1643 Cambridge St., Cambridge, Mass.

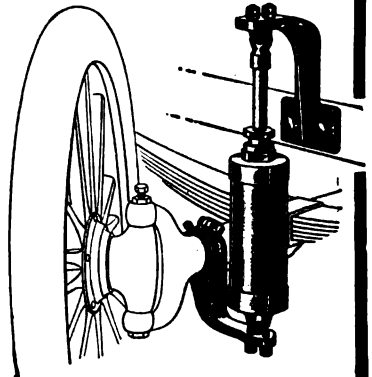

## STEEL TIRES

FULL OF AIR  
CAN'T BLOW OUT



This steel armor can be put on over any old thrown away tire and tire will last indefinitely; how can it get away if encircled by steel? The steel link bands hook to rim.

ANTI-SKID

**Kimball Tire Case Co.** 171 Broadway COUNCIL BLUFFS, IA.



**P S & Co.**

**RED INNER TUBES**

**GUARANTEED PURE PARA RUBBER**

**PARKER, STEARNS & CO., NEW YORK.**





## Relieves You of All Tire Worries

Owner has a positive feeling of security and knows that if a tire puncture or a blow-out occurs, neither he nor his guests in the car will suffer inconvenience or delay, for if anything of the kind does happen, it is merely necessary for the driver to step from the car, snap on a STEPNEY and be on his way in less than one minute.

A necessary equipment  
to every car

# STEPNEY SPARE MOTOR WHEEL

You never know when you are going to have a puncture or blow-out. It's liable to happen anytime, anywhere, in town or on tour—but when it does, as it will often, that's when the "STEPNEY WHEEL" gets in its good work, where it "makes good" as the greatest invention of the age for the automobilist in trouble. It eliminates the worry, delays and expense incident to tire troubles and insures a speedy trip over all kinds of roads.

**None of the make-shift devices imitating the GENUINE "Stepney" wheel are to be compared with it in any way.**

### HOW IT WORKS

In brief, it consists of a metal rim without felloe, spokes or hub, on which is carried an inflated tire. When not in use the wheel is carried on the side of the car in exactly the same manner as a spare shoe. On a puncture occurring, the deflated tire is left undisturbed, and the STEPNEY attached to the wheel by means of three or four clips—according to size of wheel—fitting over the clincher lip of the permanent wheel. Two of the clips are rigid and two are adjustable by thumb nuts, all that is necessary to secure the wheel being to get the fixed clips in position and tighten up on the adjustable ones, the use of a jack under ordinary circumstances being superfluous. To prevent creeping of the STEPNEY around the fixed wheel a metal lip on the smaller sizes engages one of the spokes. For the largest wheels a couple of leather straps are passed around the clip and a spoke. No tools whatever are required for mounting the wheel, the time occupied is but a few minutes, and the STEPNEY can be run hundreds of miles with safety. The STEPNEY has made good on its own merits. It does away with all tire troubles. It leaves your mind free from all worries about punctures and blow-outs. You should have one on your car.

WRITE TODAY FOR CATALOG B

**THE SPARE MOTOR WHEEL CO. of America**  
(Limited)

236 Michigan Avenue, CHICAGO

NEW YORK OFFICE, 341 Fifth Avenue



On and gone in less than a minute.



# Empire Tires

WEAR LONGEST

**EMPIRE AUTOMOBILE TIRE CO., Trenton, N. J.**

NEW YORK—148 Chambers St. and Broadway and 73d St. CHICAGO—20 LaSalle St. BOSTON—292 Devonshire St. BUFFALO—724 Main St. PENN AUTO SUPPLY CO., Philadelphia, Pa. WAITE AUTO SUPPLY CO., Providence, R. I. DENVER AUTO GOODS CO., Denver, Col. SAVELL RUBBER CO., Jacksonville, Florida. ATLANTA, GA., Durnham Rubber Co. EMPIRE TIRE & SUPPLY CO., 49 William St., Newark, N. J. EMPIRE AUTOMOBILE TIRE CO., 842 Woodward Ave., Detroit, Mich.

## BUCKEYE JACKS

ARE  
**SAFEST**

High Carbon Drop-Forged Crucible Steel Racks and Pawls insure absolutely against breaking down under load.

**BUCKEYE JACK MFG. CO.**  
Louisville, Ohio.



**DISTRIBUTING AGENTS.**  
Post and Lester Co., Hartford, Conn., Distributing Agents for New England States.  
M. G. West & Co., San Francisco, Cal., Distributors for the Western Coast.



**High Efficiency**  
**Non - Sulphating**  
**Ignition Batteries**

For Gasoline Automobiles and Motor Boats

Highest Efficiency, Strength and Durability

Write for catalogue, price list and discounts

**Tray Plate Battery Co.**  
5 Frederick St. Binghamton, N. Y.



## YOUR PROFIT, MR. DEALER

depends upon your sales. You must sell goods that are in demand and move rapidly, and give you a good profit. We would like to have you investigate

### The Celebrated Brampton Chain

They are rapid sellers and bring many duplicate orders. Every customer a SATISFIED CUSTOMER and a daily advertiser for YOU and THE BRAMPTON CHAIN. They are the strongest chain on the market. Made of self-hardening steel. We have in stock all sizes to fit American and foreign cars.

THE PRICE is the same as you pay for any other chain, in fact all automobile chains now on the market are same price to manufacturers, jobbers, dealers and users, and our prices are the same as quoted by chain manufacturers.

PRICE THE SAME. QUALITY INVESTIGATE. Get the best at the same price. Agents wanted in unoccupied territory.

WRITE FOR DISCOUNT TO DEALERS AND MANUFACTURERS. OUR LARGE CATALOG MAILED ON REQUEST.

**CHAS. E. MILLER,** Manufacturer, Jobber, Exporter and Importer **Home Office, 97-99-101 Reade St., New York City**

BRANCHES: New York City, 924 Eighth Ave.; Philadelphia, Pa., 318-320 N. Broad St.; Cleveland, Ohio, 1829 Euclid Ave.; Boston, Mass., 202-204 Columbus Ave.; Detroit, Mich., 227 1/2 & 229 Jefferson Ave.; Buffalo, N. Y., 824 Main St.; Brooklyn, N. Y., 1392 Bedford Ave.

## The HYDRO-PNEUMATIC SPRING is THE THING

Just Stop and Think

Will smooth down the roughest roads

Our Springs in connection with solid tires will make your car ride easier than with pneumatics, and consequently save all tire troubles and expenses, and eliminate all dangers connected with pneumatics. Guaranteed air tight forever.



For full information ask for booklets A and B.  
**TROJAN HYDRO-PNEUMATIC WHEEL CO. (Inc.)**  
WATERVLIET, NEW YORK



# AUTOLINE

TRADE MARK.

The Perfected **OIL** For All Types  
Lubricating **OIL** of Automobiles  
and Motor Boats

"Ask the Garage Man for it." Will not Carbonize or Soot

Manufactured by  
**WM. C. ROBINSON & SON CO.**  
Main Office, BALTIMORE, MD.

**BRANCHES:**

- Boston, Mass.
- Philadelphia, Pa.
- Pittsburg, Pa.
- Cincinnati, O.
- Indianapolis, Ind.
- Terre Haute, Ind.
- Chicago, Ill.

If your Garage does not have it, write to us direct



## THE MAN AHEAD

knows by the sound of a GABRIEL EXHAUST HORN that a high grade car is coming. They clear the road and give "class" to the car.

Easily attached, always ready, nothing to wear out, worth more than the price in satisfaction.

The GABRIEL CUT-OUT VALVE relieves back pressure of engine and assists in speeding, hill climbing and on heavy roads.

WRITE FOR PRICES

**Gabriel Horn Mfg. Co. 1410 East 40th St., Cleveland, Ohio**

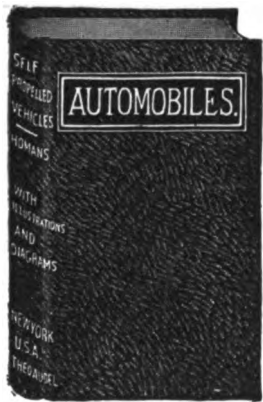
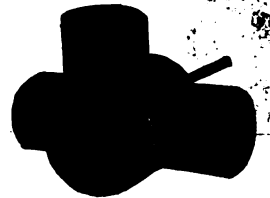

OWNERS OF AUTOMOBILES SHOULD HAVE

### Self-Propelled Vehicles

IN THEIR LIBRARIES

IT'S a new book by J. E. Homans, A.M., and tells the whole story. It explains in simple, non-technical language the mechanism and management of every type of automobile. 640 pages; 600 illustrations; complete diagrams; ready reference index. \$2.00.

ADDRESS  
BOOK DEPT., GLASS JOURNAL CO.  
Flatiron Bldg., Madison Sq., New York.

# LISTS

of all Automobile Dealers, Garages, Charging Stations, Repair Shops, Dealers and Jobbers of Supplies, Purchasing Agents, Mechanical Engineers, etc. Write for our proposition.

The AUTOMOBILE TRADE DIRECTORY Flatiron Bld., New York

## WESTON ELECTRICAL INSTRUMENT CO.

### Electrical Measuring Instruments

FOR USE IN

Electrical Carriages and in Charging Stations

Send for Catalogue

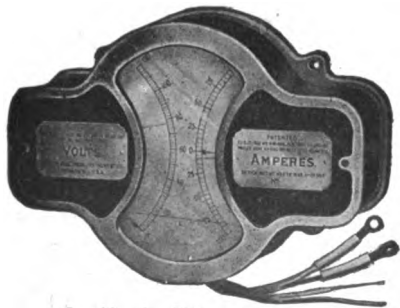

Combination Volt and Ammeter Model 30

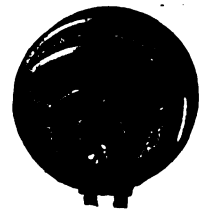

Switchboard Instrument Model 24

Main Office and Works, Waverly Park, Newark, N. J.  
New York Office, 74 Cortlandt Street



# THE GILSEY HOUSE

29th Street and Broadway  
NEW YORK CITY

This Famous Hotel is most centrally located, convenient to all the life and business of the Metropolis.

Now under the management of L. Frenkel, favorably known to the traveling public through the Hotel Albert.

THE GILSEY HOUSE has been refitted and refurnished. Rooms range from \$1.00 per day up.

Club Breakfast and meals at fixed prices



# Hotel Tuller

ABSOLUTELY FIREPROOF

Adams Avenue and Park Street  
DETROIT, MICHIGAN

## Automobile Headquarters

In centre of Theatre, Shopping and Business district.

Club Breakfast, - 40c. up

A la Carte Cafe

Grille Rooms

Every Room with Bath

Rates, \$1.50 Per Day, up

L. W. TULLER, Prop.  
M. A. SHAW, Manager

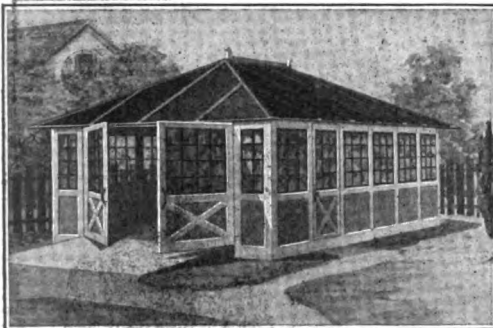

Garages,  
Boat Houses,  
Summer  
Cottages.

Inexpensive,  
Practical,  
Durable,  
Attractive  
Designs,  
Easily Erected.

## BUFFALO PORTABLE BUILDING COMPANY

216 Pearl Street, Buffalo, N. Y.

# THE ECHO HORN



SIMPLE, STRONG AND DEPENDABLE. A PERFECTLY BLENDED SIGNAL THAT RECEIVES INSTANT ATTENTION. . . . .  
Write to-day for our new booklet

## THE ECHO HORN COMPANY,

411 Tenbusch Bldg., Cleveland, Ohio  
FACTORY SALES CORPN., Western Distributors, Chicago, Illinois

# GEMMER GEAR

For Dependable Service get the "GEMMER" SIMPLE-STRONG-SAFE CAN BE READILY ADJUSTED TO TAKE UP SLACK DUE FROM WEAR—DISTINCTLY A GEAR OF QUALITY.

Every automobile owner can learn interesting facts by writing us—Write to-day stating type of car you use.

# GEMMER MANUFACTURING COMPANY

743 Merrick Avenue DETROIT, MICH.  
SALES AGENTS: Brandenburg & Co., New York. Detroit, Chicago

# The WILLET Two-cycle Engine

Also Complete Power Plants for Automobiles, Taxicabs, Delivery Wagons & Trucks

WRITE FOR CIRCULAR

## WILLET ENGINE & CARBURETER CO.

764 Ellicott Square, BUFFALO, N. Y.



# "BUCKEYE" AUTO SOAP

Linsol oil soap—strictly neutral, leaves no smoky haze, removes dirt but never touches the varnish, preserves the finish and brings out the lustre better than the ordinary kind. Goes twice as far

Write for sample and prices if your garage doesn't keep it.

J. P. DAVIES CO.,  
Dayton, O.

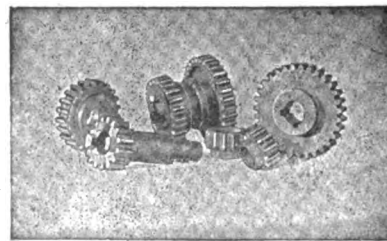

## GEARS FOR REPAIRS RUSHED

We can furnish promptly spurs, bevels and internals of open hearth, nickel or chrome nickel steel properly hardened. Also bronze and fibre gears. Send us your samples.

THE NEW PROCESS RAW HIDE CO., SYRACUSE, N. Y.

# SEASHORE, COUNTRY and CLUB LIFE

"WHERE THE KNOTTED NERVES CAN REST"

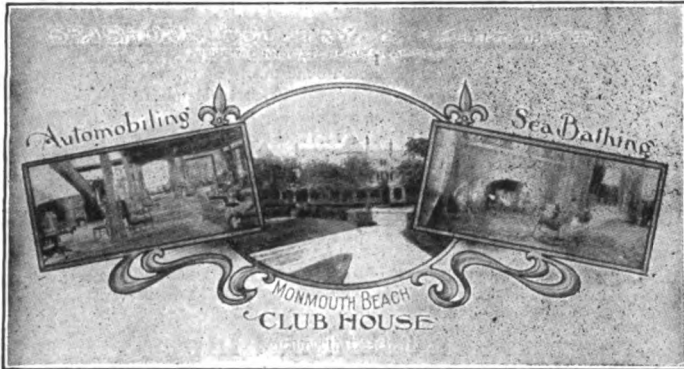

## MONMOUTH BEACH

NEW JERSEY

### HOTEL WESTMINSTER

Irving Place and 16th St.  
NEW YORK CITY

One block from Union Square, Surface, Elevated and Subway Cars. Midway between leading wholesalers and retail stores and theatres, and yet far enough from Broadway to insure comfort and freedom from the noise and bustle of that thoroughfare.

Perfectly Quiet Locality and Homelike in every respect.

EXCELLENT CUISINE.

EUROPEAN PLAN.

Single Rooms, \$1.00 per day and up. Room with Bath, \$2.00 per day and up. Parlor, Bedroom and Bath, \$3.00 per day and up. American Plan \$3.00 per day upward. Club Breakfast. Table D'Hote Dinner. Send for Booklet

THE JOHN F. HOLLINGSWORTH CO. **C. H. GODFREE, Manager**



### Send for our Map of Boston, Showing Exact Location of

When you visit Boston, if you desire the greatest comfort with the least expense, you will find Hotel Rexford all right. You will notice the central location of the hotel, its nearness to the Union Station, State House, Court House, theatres, and business houses. In other words, it is a part of Beacon Hill. Of course what you want when you visit Boston is comfort and safety, and, if economy goes with it, that makes a combination that will undoubtedly prove satisfactory. Therefore, when in town, "TRY THE REXFORD" and we will make special efforts to please you.

25 Suites with bath. 250 Rooms newly furnished with brass beds.

### NOT JUST THE ORDINARY KIND THE WHITTIER INN

SEA GATE, NEW YORK HARBOR

On the Ocean and near the City

Located in a Beautiful Residential Private Park

OPEN ALL THE YEAR



A refined, quiet, high class hotel catering to people of discrimination. It appeals particularly to Automobilers. Easily accessible from Manhattan via Brooklyn Electric; by hourly private boat to and from the Battery, N. Y., or by automobile via Ocean Parkway and other fine roads. Bus service. Excellent beach for bathing. Shower baths, dressing rooms; etc., in hotel. Tennis, rowing, sailing, etc. Three nearby cottages with hotel service afford exclusive accommodations. Booklet and rates upon application.

L. W. WHITTIER, Prop.

### WHEN IN BALTIMORE

STOP AT THE

130 Rooms Elegantly Furnished

Unexcelled Cuisine

Rooms with Bath and en Suite

Centrally Located, Opposite Camden Station,

Main Depot B. & O. R. R.

Rates \$1.00 per Day and Upwards

Send for Booklet

**HOTEL JOYCE, Baltimore, Md.**



ROBERT P. MURPHY, Prop.

### Hotel Albany

41st St. and Broadway  
NEW YORK

REMODELLED, HANDSOMELY FURNISHED, NEW THROUGHOUT  
ABSOLUTELY FIREPROOF

In the heart of the city.

500 Rooms 300 Bath Rooms

European Plan. Cuisine Unexcelled. Gentlemen's Cafe, Ladies' Restaurant and Moorish Rooms. Popular Prices. Plenty of life—but home-like.

\$1.00 per Day and up

SEND FOR BOOKLET



Meet me at the College Inn, under the Albany, New York's leading Rathskeller, a place to eat, drink and be merry. Music.

### The Densmore

KANSAS CITY, MO.

The newest hotel in the city. 200 Rooms. 150 with Private Bath. Convenient to all centers. Reached by all car lines. The coolest and cleanest location. Special rates by the month or week.

TRANSIENT RATES:

\$1.00 to \$2.50 Per Day, European  
\$2.50 to \$4.00 Per Day, American

DENSMORE HOTEL CO., Props.





There is only ONE

# ALBANY GREASE

A Lubricant Unsurpassed for Automobiles and Motorboats

ONLY MADE BY **ADAM COOK'S SONS**  
313 West St., N. Y. City

## New DOVER Combination Measure and Funnel

The combination measures and funnels are made of extra heavy polished tin. *This is one of the handiest and most convenient articles we have ever made.*

**No More Lost Funnels**

We can also furnish the above copper plated and with brass wire strainers for automobile use.

Prices on Application

**DOVER STAMPING & MFG. CO.**  
385 Putnam Avenue, CAMBRIDGE, MASS

No.	Di. bot.	Total height
1	1 pt. 2 1/2 in.	4 1/2 in.
2	1 pt. 3 1/2 in.	5 1/2 in.
3	2 qt. 4 1/2 in.	7 1/2 in.
4	4 qt. 6 1/2 in.	12 1/2 in.

## Rock Island Automatic Swivel Vise

We make a size, this type, for automobiles. The base is fastened to the step or tool box at all times. The vise can be kept in the tool box and when needed is instantly ready for use. No screws, bolts, pins, etc.

Send for Catalogue.

**Rock Island Tool Co., Rock Island, Ill.**

## The "Long-Arm" System Co.

CLEVELAND, OHIO

### 1909 MODELS ON AXLES (3 SIZES)

Cone Clutches, Steering Reaches, Buffers, Propeller Shafts, Hand Levers, etc. SEND FOR CUTS, prices, etc. Your own designs! manufactured IN QUANTITY. Our gear cutting is now beyond reproach. If you cut and chamfer your own gears you need our

**Automatic Tooth Chamfering Attachment**

Sales Department, THE AMERICAN DISTRIBUTING CO.  
American Trust Bldg., Cleveland, Ohio

## TRIPLE ACTION SPRINGS

PAT. PENDING

Will add much to the Easy Riding Qualities of any car. Can be equipped to all makes. Many automobile manufacturers have already adopted them as standard equipment.

**THEY HELP SELL CARS**

Write for Proof Positive of every claim

**TRIPLE ACTION SPRING CO.**  
1505 Michigan Ave., Chicago

Dealers, get our great agency proposition. We want representation everywhere. Write

Type 12

Type 11—Spring

## —STRONG AS AN ELEPHANT—

Holds any Blowout

Fits any Tire

Instantly Adjusted Reasonable in Price

Patented May 21, 1907 Other Patents pending

**UNIVERSAL TIRE PROTECTORS**

are made of special selected chrome leather with reinforced steel armored tread. Secured to any tire in 90 seconds so tightly they cannot creep.

Universal Tire Protector Co.  
Angola, Ind.

Send or descriptive circular and price list

Western Distributors, EXCELSIOR SUPPLY CO., Chicago.  
The ANGIER CO., 75 Boylston Street, Boston, New England Agents

## The Emergency Wheel

Eliminates Tire Troubles

**Ask the Tire Man**

It is sold through the Trade Jobbers and Dealers

Write for Description and Price

**BLACK MANUFACTURING CO., FORT WAYNE, Ind.**

New York Office: Room 234, Thoroughfare Bldg., Broadway, 57th and 58th Sts. Keeney & Mason, Sales Agents

Chicago Office: 1303 Michigan Ave. Chas. Falk, Sales Agent

## The Pioneer and Aristocrat of Exhaust Blown Signals

AUTOCHIME PATD

### A SUPERIOR HORN

Designed and Built for those desiring Distinction and Quality rather than price. Perfected in every detail—it Excels in Simplicity, Durability, Tone and Finish. Sold and Recommended by the Best Dealers and Supply Houses. CAUTION—It is closely imitated. The genuine has the name "GRAY AUTOCHIME" on the bell—others are imitations.

**GRAY-HAWLEY MFG. CO.**  
DETROIT, MICHIGAN

Write for Catalog A. **MAKERS OF**  
GRAY MUFFLERS, VALVES, PEDALS, WHISTLE OUTFITS FOR MOTOR BOATS, SKIPPER MARINE ENGINES, ETC.

1908

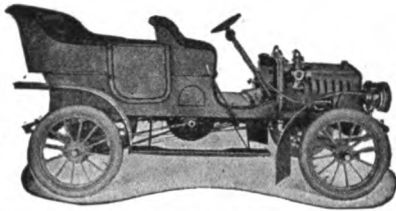

\$1350

**The MASON**

"THE STRONGEST AND SWIFTEST TWO-CYLINDER CAR IN AMERICA."

If you haven't had a ride in the MASON, you have not as yet realized the vast possibilities of the Motor Car. Take a ride in all the other cars, then ride in the MASON. We will guarantee it to do everything any other car does regardless of horsepower, and do it better. Try the MASON, especially on hills—it will surprise you.

RUNABOUT—SAME CHASSIS, \$1250.

MASON MOTOR CAR CO., 114 East 5th Street  
DES MOINES, IOWA

**WELCH**

"The Most EFFICIENT Car"

4 Cyl. 50 H.P.  
6 Cyl. 75 H.P.

**WELCH MOTOR CAR CO.**  
PONTIAC, MICH.

**The THOMAS**

America's Champion  
in the  
New York-Paris Race  
Send for map and route card.

**E. R. THOMAS MOTOR COMPANY**  
Member A. L. A. M. BUFFALO, N. Y.

**THE MIDLAND=A NEW CAR**

proven better than anything else at the price—built by men who have been in the automobile business for many years—by men who know how. The Midland is perfect in plan and action. If you have contemplated spending in the neighborhood of \$3,000 for a car, write us for full description of the Midland at \$2,250.

**MIDLAND MOTOR CO. Moline, Ills.**

New York Agents: { Allenhurst Garage and Auto Station  
135-147 West 37th Street

**ALL GENUINE**  
**MOSLER**  
**"Spit-Fire"** TRADE MARK  
**PLUGS**  
**HAVE**  
the name on Porcelain and Base, are contained in boxes on which is printed an illustration of a PLUG SHOOTING A FLAME. (Registered Trade Mark)  
**WE PROTECT**  
our Registered Trade Mark  
**DEALERS AND JOBBERS BEWARE !!**

The Imitator will show you THIS but  
The Imitation has not got THIS, the indispensable patented side-cleaning holes.  
You can Purchase the GENUINE for the same money or a trifle more,—why buy an inferior imitation?

**INSIST ON THE GENUINE**  
WITH NAME ON PORCELAIN & BASE  
A. R. MOSLER & Co., 163 W. 29th St., New York City

Ownership of the Full-Jeweled

includes the certainty of constant, efficient service at a remarkably low cost of maintenance.  
Advance Catalogue upon request.  
**CORBIN MOTOR VEHICLE CORPORATION**  
Member Association Licensed Automobile Manufacturers  
NEW BRITAIN CONNECTICUT  
1488 Broadway, 62d Street, New York

**Moline "1909"**

**THE MOLINE ROADSTER**  
In the purchase of which you are assured mechanical perfection.  
In appearance it is of tasty outline and the equal in every respect to its high priced rivals. Let us tell you more.  
**MOLINE AUTOMOBILE CO.,**  
EAST MOLINE, ILL.  
Members American Motor Car Mfgs. Association.

An Exclusive  
Feature of

HAM'S  
Cold Blast  
Lamps

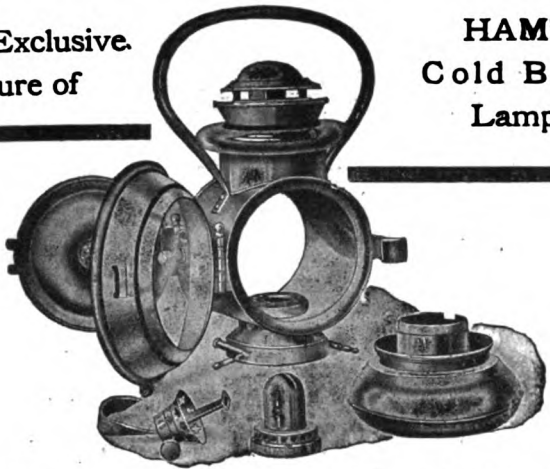

Notice How Simple and Easy  
It Is to Get at Every Part of a  
Ham "Cold Blast" Lamp

One of the reasons why they are Superior  
to any other make of Oil Burning Auto-  
mobile Lamps on the market. A trial will  
convince you.

*We would like to send you one of our catalogues.  
Write to-day. Address Dept. "B"*

**C. T. HAM MFG. CO.**  
ROCHESTER, N. Y.

Let Us Make Your  
**HUB CAPS,  
SIDE LEVERS,  
and  
LAMP BRACKET  
CASTINGS**

from  
**Manganese Bronze  
or Yellow Brass**

They Will Be Smooth and Accurate to  
Pattern.

**SYRACUSE ALUMINUM & BRONZE CO.,**  
SYRACUSE, NEW YORK  
THOS. J. WETZEL, Eastern Sales Agent, 29 W. 42nd St., New York City

## The K-W MAGNETO

HIGH IN QUALITY  
LOW IN COST  
RELIABLE IN ACTION  
EASY TO APPLY  
GIVES MORE POWER.  
AND USES LESS FUEL.

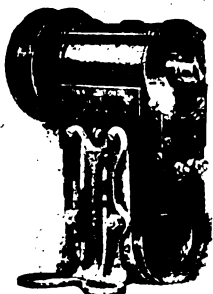

MODEL F

Belt Drive, \$35.00, with  
bracket as shown, for attach-  
ing to frame of car. Made  
especially for Ford Run-  
abouts, but good on any car.  
5 ft. belt and fasteners, \$1.00

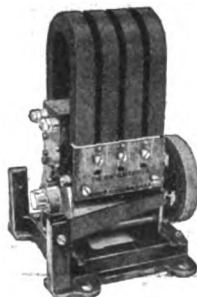

MODEL B

Friction Drive, \$35.00.  
Chrome tanned oil and  
water-proof friction—  
will not slip.

Install a K-W Magneto on your car and  
learn what it is to have real ignition  
without further expense or trouble.

**YOUR CAR IS NO BETTER  
THAN ITS IGNITION**

If you are using batteries you are not get-  
ting all the power there is in your engine.  
The K-W Magneto will start your engine  
without batteries and run it faster than  
any battery and give you more miles per  
gallon of gasoline.

We want to send you our catalogue.

**THE K-W IGNITION COMPANY**

34 POWER AVENUE CLEVELAND, OHIO

New York Representative, A. H. Green & Co., 1686 Broadway  
Boston Representative, W. J. Forbes, 220 Congress Street  
Buffalo Representative, F. A. Ballou, 879 Main Street

## HALLADAY

cars are not mile a minute cars BUT for HILL  
Climbing, for HEAVY roads, for EASE of riding,  
for EASE of operation, the HALLADAY is the  
peer of all. Undoubtedly the most flexible car  
on the high gear in the market. Agencies  
established in five leading cities in the past eight  
days is the best evidence that there is point in the  
above statements.

**STREATOR MOTOR CAR CO., Dept. 3, Streator, Ill.**

## 1908—DORRIS—1908



Model C, 30-H.P.,  
4 Cylinder  
Price \$2,500.

THE CAR OF SIMPLICITY.

The days of large cars are over, why not buy a car that will take you  
everywhere, with less gasoline, general upkeep and tire expense?

**DORRIS MOTOR CAR CO., St. Louis, Mo.**

# Republic Tires

We want you to know the Republic before your tire breaks down.

Republic Rubber Company  
Youngstown, Ohio

New York, 232 West 58th St.  
Boston, 25 Irvington St.  
Philadelphia, 830 N. Broad St.  
Chicago, 116 Lake St.  
Detroit, 246 Jefferson Ave.  
St. Louis, 3964 Olive St.  
Pittsburg, 136 6th St.

Seattle, 1419 Broadway.  
Denver, 1721 Stout St.  
San Francisco, 119 Beale St.  
Cincinnati, 8th and Walnut Sts.  
Toledo, 2215 Monroe St.  
Indianapolis, 208 S. Illinois St.  
Cleveland, 1120 Euclid Ave.



## NIGHTINGALE WHISTLE DEMANDS RIGHT OF WAY

It is the best warning signal obtainable, and possesses many distinct advantages. It can be heard for miles, but is not harsh and rasping like ordinary signals. It has a SIX NOTE TRILL, melodious and pleasing to the ear. It never fails and is ALWAYS reliable. Cannot become clogged, for it is closed when not in use and cleanses itself AUTOMATICALLY. Any chauffeur can easily attach it to exhaust pipe or muffler. Operates from ANY PART OF CAR by hand-pull, lever or pedal.

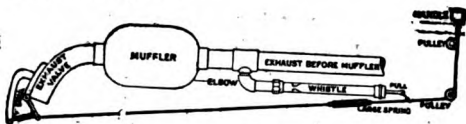

Write for Catalog No. 15 for full particulars and prices

For Garage purposes we sell a Water Jacked Air Compressor of High Efficiency

Write for Booklet No. 16

Comptoir d'Innovations pour Automobiles  
1692 Broadway  
NEW YORK

Southern California Agents: E. A. Featherstone Co., Los Angeles. Northern California Agents: Geo. P. Moore Co., and H. W. Bogen, San Francisco. Essex County Agents: Brick Church Auto and Supply Co., East Orange, N. J. Philadelphia Agents: Bergdoll Motor Car Co., 323 N. Broad St.



"The Simple Generator"  
DIETZ "HANDY"

**A CARD**

### DIETZ Motor Car Lamps Motor Boat Lamps

WE beg to notify Manufacturers, Jobbers and Dealers in Motor Cars, Motor Boats and Accessories, that we have in preparation a complete

### 60 PAGE CATALOG

Our line will show more and better Lamps than ever before. Prices will continue competitive, while burning qualities, finish, style and durability remain unexcelled. Wise buyers will not place orders until they have seen the Dietz Improved Headlights and Searchlights, Dietz Popular "Handy" Generators, Dietz Electric Headlights, the Dietz varied assortment of Oil Lamps and our new Motor Boat Equipment.

Yours very truly,  
**R. E. DIETZ COMPANY,**  
60 Laight Street,  
NEW YORK CITY

**THE ORIGINAL**

**DIETZ  
MOTOR CAR  
LAMPS**

**NONE "JUST AS GOOD"**

ESTABLISHED 1840



## MOSS CUTS

will add 100 per cent. to the selling quality and pulling power of your advertising—give the "life," "snap" and "go" necessary to sell your product.

When you buy "Moss" Cuts you buy with a certainty of getting as perfect cuts as can be produced for letter-press printing. **TRY US**

**MOSS Photo-Engraving Co.**  
295-309 Lafayette St., Corner Houston,  
"Puck" Building, NEW YORK



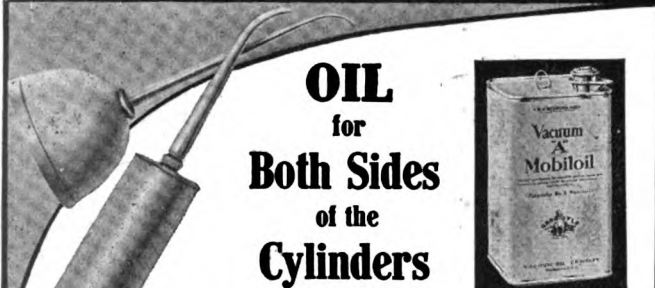

**OIL**  
for  
**Both Sides**  
of the  
**Cylinders**

Upon perfect lubrication *inside* the cylinders depends the very life of your automobile. *Outside* the cylinders, on other parts of the automobile, it's only a question of wear. Lubrication in either case is made a scientific certainty by the use of MOBILOIL, the friction-proof, *trouble-proof* oil. There's a grade of

**VACUUM**  
**MOBILOIL**

for your car, whether steam or gasoline, air cooled or water cooled. Our booklet, sent free on request, tells which grade of MOBILOIL to use. Also contains much useful information for motorists.

MOBILOIL in barrels, and in cans with patent pouring spout, is sold by all dealers. Manufactured by

**VACUUM OIL COMPANY**  
Rochester, N. Y.



**Reliance**  
(REG. U.S. PAT. OFF.)  
**SPARK PLUG**  
TEST  
AND  
**PROOF.**  
"INFALLIBILITY"



This is the Demonstration which proves beyond a doubt the value of a Spark Plug

A Plug that will Spark in water will spark under any conditions found in a gasoline engine cylinder, for soot, oil, carbon, or their combinations, cannot be compared with water as a short circuiting matter. Facts and actual tests prove this.

 \$1.50 each, at your dealers or postpaid on receipt of price. A terminal clip packed with each plug.

**JEFFERY-DEWITT CO.**  
222 High Street NEWARK, N. J., U. S. A.

**You can't foul this plug so it won't work.**  
**Heat won't break the insulation**  
**It can't become short-circuited**  
**It can't leak**

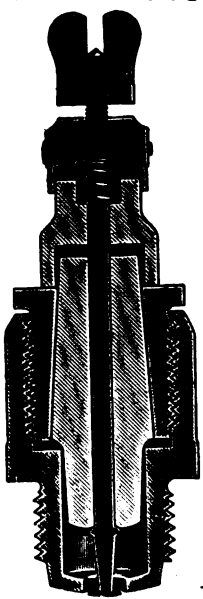

**The Edco Plug**

is a better plug than any other because it is better made, from better designs and better material than any other plug.

Look at its construction.

The man who knows will readily see its quality.

Ask your dealer to show you an **Edco** Plug, or write to the New York office for further particulars and price.

**CH. DIEN**  
43-45 West 34th Street  
NEW YORK  
Sole Agent for U. S. and Canada

Interior construction of the **EDCO PLUG** Made by **Edouard Dubied & Co., Couvet, Switzerland**

**B  
E  
A  
V  
E  
R**



**MOTORS**

Meet successfully every condition of service—hills, hard roads, any weather. They are high speed—powerful. They respond instantly to your control are smooth, silent runners, easy of access and easy to install. Built after designs which give efficiency in operation and durability. Parts are interchangeable. All motors are four cycle.

TWO-CYLINDER HORIZONTAL OPPOSED  
Made in two sizes, 12 H.P. and 18 H.P.  
FOUR-CYLINDER VERTICAL, 28-30 H.P.

WRITE for FREE BOOKLET

**"WORK LIKE BEAVERS"**



**BEAVER MFG. CO.** 239 OREGON ST. MILWAUKEE WIS.

**New LATEST Supplementary**

**WRITE FOR IT  
Revised Prices**



**The Growing House.**

**MANUFACTURERS, DISTRIBUTORS  
AND JOBBERS OF**

**Automobile Parts, Supplies and  
Accessories**

**NEUSTADT AUTOMOBILE & SUPPLY CO.,  
3954 OLIVE STREET, ST. LOUIS, MO.**

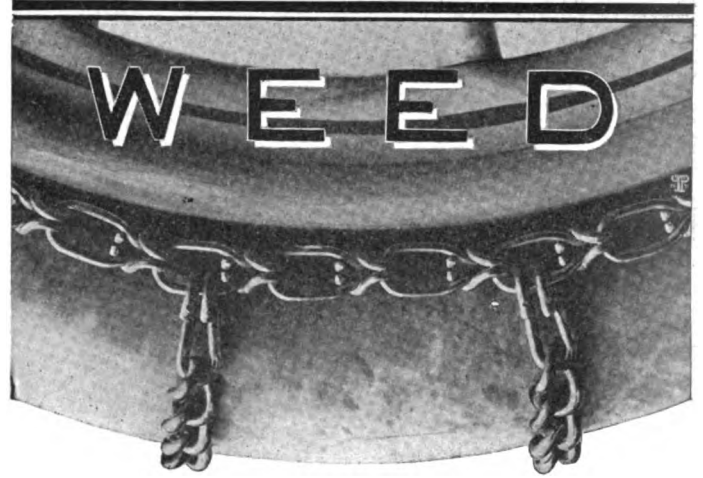

**WEED WEATHER!**

**When it starts to rain—that's the time  
to put on your WEED CHAINS**

It is not possible to skid or slip, and your  
tires will be preserved, and the road or street  
is not injured through the use of WEEDS.

WRITE FOR BULLETIN

**WEED CHAIN TIRE GRIP COMPANY  
27 Moore St., New York**

**★ THE "STAR" ★  
ODOMETER**

**Correctly Tells the Distance Traveled**

**F**OR the Doctor or Business  
man this Instrument will be  
found of inestimable value where  
an accurate record of the miles  
traveled for the Trip or Season is  
desired.

The "Star Odometer" is  
simple in construction;  
positive in action and  
beautiful in design. Can be  
conveniently attached to  
floor or dash, and is easily  
readable, dial and figures being large and distinct.

No town car is properly equipped without a  
"Star Odometer."



**FULLY GUARANTEED.  
Reliable Agents wanted everywhere.**

**STAR SPEEDOMETER CO.  
DANVILLE, PA.  
Write to us.**

**Only \$10**

**Sterling  
8-Day  
Motor Clock**

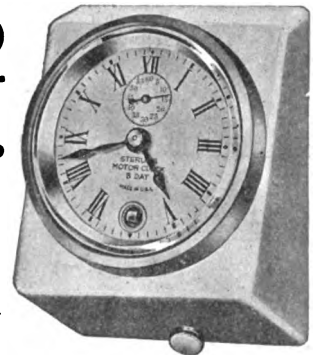

Silvered dial, 3 1/4 inches across; heavy beveled crystal;  
offset polished brass case, 4 1/2 inches up and down by  
3 1/2 inches across and 2 3/4 inches deep at lower part.  
Can be removed from dash only by owner with key.  
Accurate mechanism sealed from dust, mud or rain.

*Dealers: Be the first to show and sell this*

**THE  
POST & LESTER  
CO.**

**Hartford,  
Conn.**

**Boston, Mass.  
821 Boylston St.**

# "Don't Take the Dust"

BE PREPARED WITH

*The Automatic*  
FORMERLY THE GORHAM  
 Folding DUST AND WIND Shield

Instantly raised or folded with one hand, without decreasing the speed of the car or leaving the seat. So simple a child can raise or fold. All brass tube and glass. Anti-rattle.

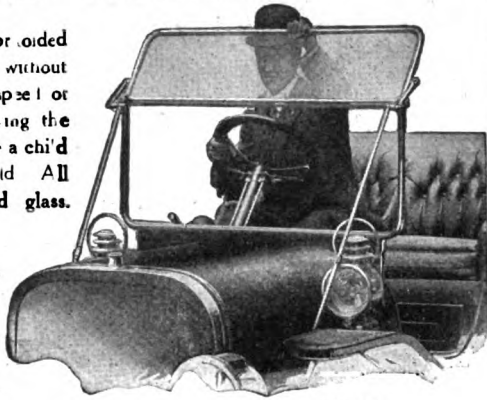

Send for Catalogue.

No. 1—29 x 41 1/2 inches \$50.00  
 No. 2—29 x 44 inches 55.00

**C. A. MEZGER, Inc.,**  
 1739 Broadway NEW YORK  
 NATIONAL SALES CORPORATION  
 Factory Sales Manager, 296 Broadway, New York City, N. Y.

**Don't Buy A Coil**  
 for your car or boat, until you have thoroughly investigated the ignition problem. Then you will select THE Coil—a



**Coils** { FOR AUTO OR MARINE USE } **Timers**  
**Meters** { } **Switches**

Catalog 13B yours for the asking

**GONNETTIGUT** TEL. AND ELECTRIC **COMPANY, INC.**  
 50 Britannia St., Meriden, Conn.

# Do You Know the AUTO-CLE?

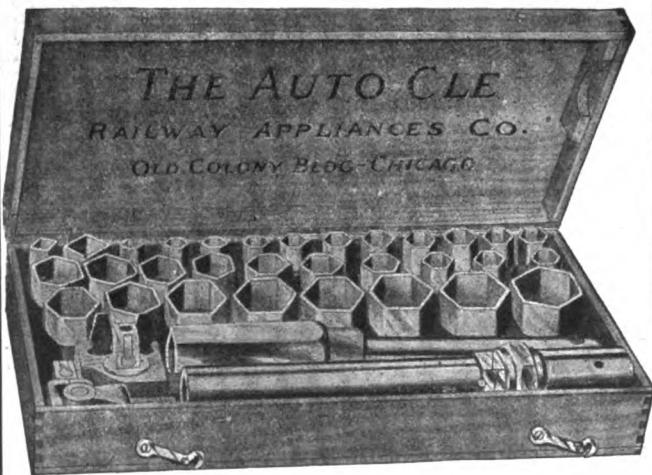

It is a ratchet-acting socket wrench that enables you to reach every nut or bolt on any automobile and make adjustments with comfort, convenience and accuracy.

More breakages occur through neglect than accident, and the possession of an Auto-Cle is an insurance against repair bills. The new auto set in leather case is as indispensable as a jack or tire pump and you can't afford to be without it. Sold by all live dealers.

Factory Sales Corporation 233-235-237 Randolph St. Chicago

# The MARVEL CARBURETER



## "MARVEL" Carbureters

are made for the particular motorists to whom absolute reliability is a matter of importance and who want the maximum of satisfaction with minimum cost and minimum trouble

The use of a Marvel Carbureter means a better car, absolute dependability regardless of speed, roads or atmospheric conditions. It supplies a uniform mixture always—and an increase in the power of your engine.

### Its Principal Features are:

Ease of adjustment—good mixture at all throttles—great range—absolutely non-dripping, thus saving gasoline—workmanship unsurpassed—low in price and absolutely guaranteed satisfactory or money refunded.

In your own interest—write for full particulars and price. YOU OUGHT TO KNOW—WRITE TODAY

**MARVEL MFG. CO.**  
 410 So. Meridian St., INDIANAPOLIS, IND.

# The Autocar

BUILT BY BRAINS  
FOR  
MEN WHO KNOW

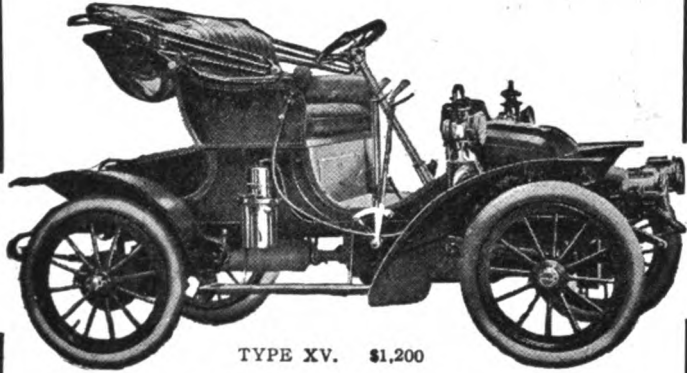

TYPE XV. \$1,200

The general use of this car by physicians in making their daily rounds has earned for it the well deserved appellation

### THE DOCTOR'S CAR

This car comes to you with full equipment, including top, storm apron, gas lamps and generator. It is the easiest car to care for and the most economical to run.

The AUTOCAR CO., Ardmore, Pa.  
Member A. L. A. M.

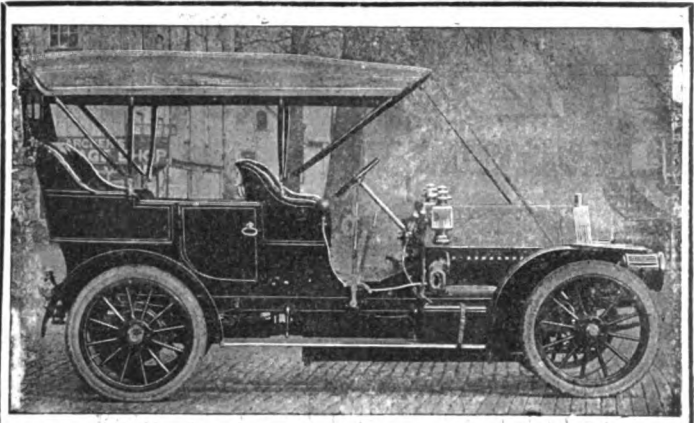

## The "JEWEL 40"

THE "NON-SKIDDING" CAR

*Specifications:*

- Hedgeland Equalizer or Non-Skidding Device.
- Wheels . . . . . 36".
- Tires . . . . . Diamond, Firestone, Goodyear, or Michelin.
- Wheel Base . . . . . 120".
- Tread . . . . . 56".
- Engine . . . . . 4 cylinder, vertical.
- Bore and Stroke . . . . . 4 1/2" x 5".
- Ignition . . . . . Double. Bosch Magneto and Connecticut Coil and Storage Battery.
- Lubrication . . . . . Double. Six Feed Mechanical and oil level pump in crank case.
- Axles . . . . . Timken.
- Bearings . . . . . Roller.
- Body . . . . . 7 passenger.

Write for Catalog.

THE FOREST CITY MOTOR CAR COMPANY  
124 WALNUT ST., MASSILLON, OHIO

# KINGSTON

1908 Spark Coils

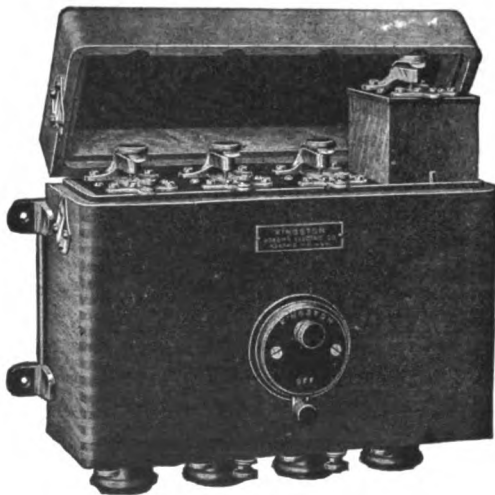

High grade throughout. For finish, positive working and low battery consumption. cannot be excelled.

KOKOMO ELECTRIC CO., Kokomo, Ind.

Western Sales Agent  
F. J. ALVIN  
237 Randolph Street  
Chicago, Ill.

Eastern Agent  
CHAS. E. MILLER  
97-101 Reade Street  
New York, N. Y.

Canadian Agents  
JOHN MILLER & SON  
Montreal and  
Toronto

# MASURY

SUPERFINE  
AUTOMOBILE  
COLORS  
AND  
VARNISHES

MANUFACTURED BY

JOHN W. MASURY & SON

NEW YORK  
CHICAGO - ST. LOUIS - MINNEAPOLIS

— ESTABLISHED 1835 —



# KNOX

In buying an automobile the problem is to find a car with the greatest number of points of excellence and the fewest faults, at a satisfactory price. In this connection you will find the Knox in a class by itself. In no other car, American or foreign, will you find combined these three features.

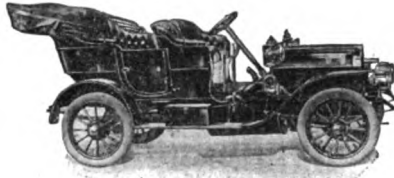

"H" Tonneau . . . \$2,600  
With Top . . . 2,750

**Knox Unit Power Plant**  
**Knox Absolute Three Point Suspension**  
**Knox Straight Line Drive**

Some cars have one, a few have two, but no car except the Knox has all three features. In addition, Knox cars are either Air or Water Cooled. Knox reliability is well known, and the car is

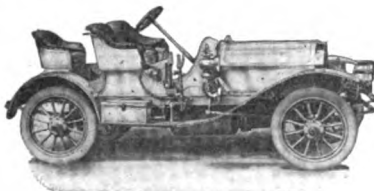

"L" Sportabout . . . \$2,650  
With Glass Front . . . 2,700

very powerful and speedy for its weight. It is the highest grade car

at a medium price on the market.

Send for illustrated pleasure Car Catalogue "A," or Commercial Car Catalogue "B," or both.

**Knox Automobile Co.**  
**Springfield, Mass.**

Member A. L. A. M.

# National

MOTOR CARS

afford the purchaser the very best value to be had on the market at present. All Nationals are equipped with ball-bearings throughout, including the motor.

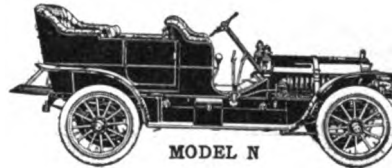

MODEL N

Model K, 4-cyl., 4 1/2 x 5  
\$3,500

Model N, 4-cyl., 5 x 5  
\$3,700

ALL NATIONALS HAVE TWO COMPLETE SYSTEMS OF IGNITION

Model R, 6-cyl., 4 1/2 x 4 1/2  
\$4,200

Model T, 6-cyl., 5 x 5  
\$5,000

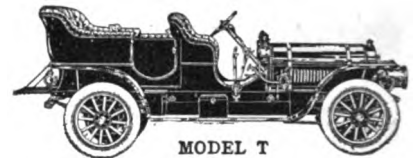

MODEL T

Write for particulars and our Booklet  
"What Owners Say About Their Nationals"

**NATIONAL MOTOR VEHICLE CO.**  
1000 East 22d Street INDIANAPOLIS, IND.

# Rauch & Lang Electrics

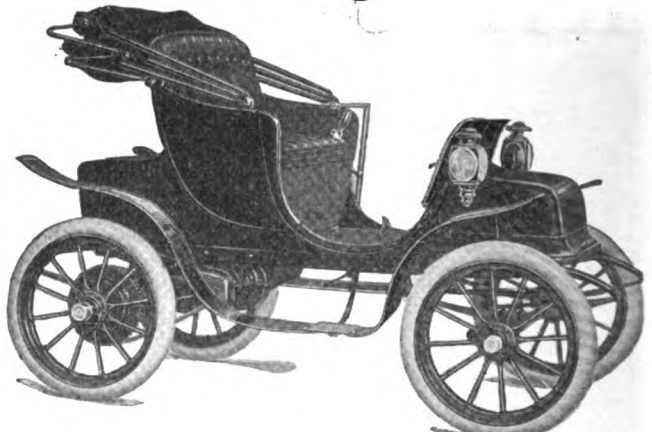

As Electric Vehicles are used largely by women, Safety—Ease of operation—Comfort—Cleanliness and Elegance of finish are essential requisites.

Rauch & Lang Electrics are noted for their pre-eminence in these qualities.

Among the many exclusive features of Rauch & Lang Electrics are our Electric Brake Control and Safety Locking Device. These are the most remarkable safety appliances ever invented and should be investigated before you buy any car.

Visit any of the following salesrooms or write for catalog describing and illustrating our eleven different models.

**THE RAUCH & LANG CARRIAGE CO.**  
Fifty-five years experience building carriages of quality.  
629 Superior Avenue, Cleveland, Ohio

AGENTS:  
Chicago, Ill.—C. Kimball & Co., 215 Michigan Ave.  
Detroit, Mich.—Wm. F. V. Neumann & Co., 1343 Woodward Ave.  
St. Louis, Mo.—Union Electric Light & Power Co.  
Toledo, Ohio—Toledo Motor Car Co.  
Davenport, Iowa—Mason Carriage Co.  
Manchester, N. H.—Jas. A. Whitman, Pembroke Bldg.  
Erie, Pa.—A. H. Murphy, 918 State St.  
Omaha, Neb.—J. J. Wright & Co., 1015 Farnum Ave.  
Philadelphia, Pa.—Hershall Motor Car Co.  
Oklahoma City, Okla.—L. Van Camp, 614 West Grand Ave.  
Cincinnati, Ohio—Suburban Auto Garage.  
Denver, Col.—Columb Auto Co., 1343 & Colfax Ave.  
Kansas City, Mo.—Pletcher-Corward, Jr. Auto Co.  
Baltimore, Md.—Bier's Garage, North & Madison Ave.  
St. Paul, Minn.—F. W. Ramsey, 250 Grand Ave.  
Rochester, N. Y.—Arthur McNeil, 28 Union & Court Sts.  
Cochran, Ind.—Tennison & Park.  
Marietta, Ohio—E. E. Coon, 22 E. Clair Bldg.  
Springfield, Ill.—E. Head Bldg. Co., 200 E. Monroe St.  
Atlanta, Ga.—M. Rich.

**HERE** is proof that the entire country is awaking to the structural operative and economical advantages of the



**Over Any Other Car**

**Elmore Town Car \$2,250.00**  
**Elmore Taxicab - 2,250.00**

In spite of the fact that ours is the only factory in America to increase its output over 1907, almost every Elmore agent is confronted with a shortage of cars.

Not only would most of the agents gladly pay a premium for more cars, but we have been compelled for two months to refuse requests for new agencies and requests from our larger dealers for an increased allotment of cars.

Surely this condition should prove beyond question the fact that the entire country is awaking to the structural, operative and economical advantages of the valveless, two cycle Elmore over any other car. The time is past for an argumentative discussion of these advantages. They have of themselves pushed the Elmore into a position which makes it the most-talked-of car in the automobile world to-day.

**Elmore Manufacturing Co.**

1304 Amanda Street  
 CLYDE - OHIO

**HOW CAN YOU INCREASE YOUR HORSEPOWER 25%?**

By cleaning out the carbon deposited in cylinders, piston heads, piston rings, valves and valve stems. Every engine is affected by carbon deposits, and its efficiency decreased twenty-five and even fifty per cent. Engines carbonize as readily, and on the same principle as a lamp chimney smokes up. The only way to recover this lost horsepower is to dismount and clean the engine, or to use

**DECARBONIZER**

Decarbonizer is a harmless, oily compound which dissolves and removes the carbon. You simply pour it into the cylinder, start your engine, and it immediately volatilizes the carbon, in which form it passes out exhaust as smoke.

It is absolutely harmless to metal. It cleans out and brings your engine up to maximum horsepower, increasing it, on the average, 25%.



Your engine, right now, undoubtedly is not doing its best work because of carbon deposits. Decarbonizer will remove it immediately, and used periodically, will keep your engine to top notch efficiency, and perfectly lubricated.

Don't take our word for it, prove it yourself. Use one-half of a quart can and if you are not positively satisfied that decarbonizer "makes good" on all our claims, return it at our expense, and we will refund your money.

Don't lose time in restoring your engines to their maximum horsepower. Fill out and return the attached coupon today.

**GENERAL ACCUMULATOR & BATTERY CO.,**  
 150 Second St.  
 Milwaukee, Wis.

**RETURN THIS COUPON:**

General Accumulator & Battery Co. I enclose herewith \$1.50, for which please send me a quart can of Decarbonizer, with the understanding that after having used one-half, I may return it at your expense, and receive back my money, if I am dissatisfied with results.  
 Name..... Address.....  
 I usually buy my automobile supplies from the following concern:  
 Name..... Address.....

"It's nice to know how far you go:  
And this will show the Speed,—also."

# Veeder (TACHODOMETER)

## THE SCIENTIST'S SPEED INDICATOR

Ball  
Bearing  
Through-  
out

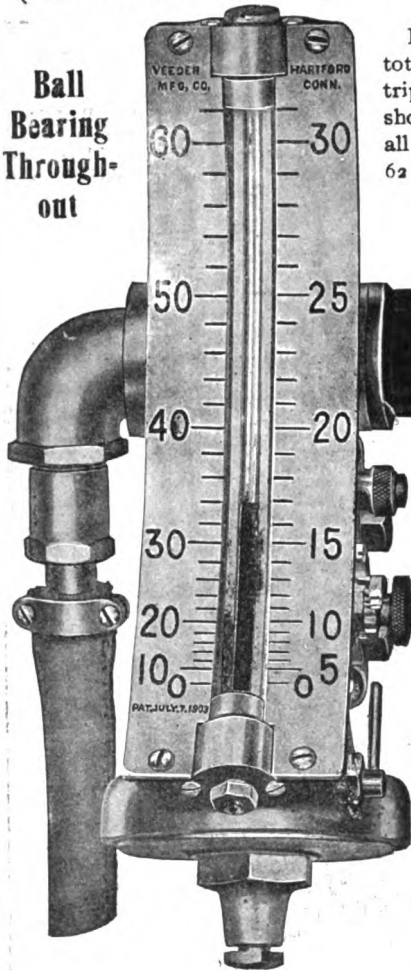

Registers how far, total, and for each trip. Double scale shows each speed at all times, from zero to 62 miles per hour

ONLY SPEED INDICATOR THAT CAN BE ACCURATELY SET TO ZERO AT ANY TIME BY THE OWNER.

NO SPRINGS or variable elements, no delicate mechanism —ONLY ONE MOVING PART

Price, complete, ready to put on any car \$75.00

Thousands of Veeder Odometers in use to one of any other make.

The Veeder Mfg. Co.,

Sargeant St.,  
HARTFORD, CT.

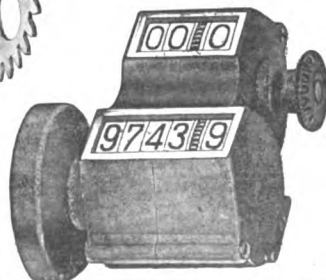
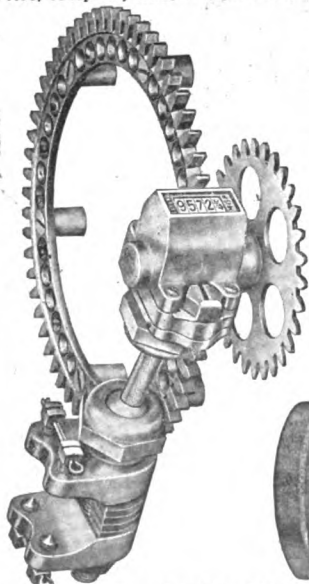

FORM B ODOMETER Complete, ready to put in any car, \$10.00

FORM D or DASHBOARD ODOMETER Complete with flexible shaft and attaching fixtures, ready to put on any car, \$20

# AJAX WRAPPED TREAD TIRES

AJAX—

The tire that proved a pneumatic tire can be made so good, so sure in service—results its maker

can guarantee it for 5,000 miles—and not go broke.

We don't know any other pneumatic tire that can be guaranteed for any definite time

or distance; but we do know AJAX can be—and make good ninety-nine per cent of the time.

For the other one per cent you get tire insurance and we get your trade.

Write for copy of Guarantee, stating what size tire you are using. Address Department C.

AJAX-GRIEB RUBBER COMPANY

GENERAL OFFICES: N. E. Cor. 57th Street and Broadway, New York  
Factories: Trenton, N. J.

BRANCHES:

New York, 1776 Broadway  
Boston, 810 a Boylston St.  
Chicago, 1418 Michigan Ave.  
Detroit, 743 Woodward Ave.  
Denver, 1520 Cleveland Place  
Seattle, 1102 Broadway  
San Francisco, 400 Golden Gate Ave.  
Los Angeles, 1040 S. Main St.

Agents in all large cities.



## ONE YEAR GUARANTY

Our purpose has been to build the best car in all the world. How well we have succeeded is told by our customers themselves, who, as a class, are the most prominent men of affairs in this country. Send for our complete catalogue and book of customers' letters, of which the following is but one:

ANDOVER, MASS., January 7, 1908.  
In reporting on the work of my Matheson for the season, I have to say that it has come nearer being the ideal touring car that I have been eight years hunting for than anything else I have had. It has speed over sixty miles per hour with five people aboard and power on the hills and yet runs slowly without fuss or bother in traffic in towns—eight miles per hour being easy, smooth and comfortable. It rides easier and has cost less for repairs than any of the twenty-two (22) cars I have previously had and I have driven it 13,000 miles since I got it June 7th last and to day I think I drove it faster than any time before, over sixty miles per hour with five passengers. It is by far the easiest car on tires I have ever had. One tire made 11,800 miles, one 8,800 and the others from 4,000 up.

I know you will be as glad to hear as I am to tell of the satisfaction I have had with the car.

(Signed) HARLAN W. WHIPPLE.

Note.—There is no better known or more exacting motor car enthusiast and sportsman in this country than Mr. Harlan W. Whipple, ex-president of the American Automobile Association

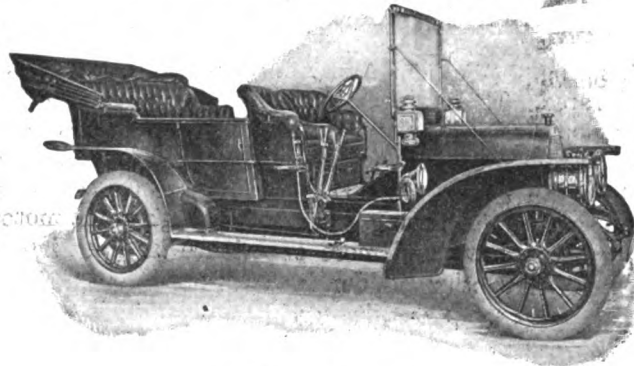

### Dealers

- NEW YORK CITY..... A. G. Southworth Co. Inc., 1735 Broadway.
- BOSTON MASS..... Matheson Co. of Boston, 1230 Massachusetts Ave Cambridge, Mass.
- CHICAGO, ILL..... Bird-Sykes Co., 1470 Michigan Ave.
- PHILADELPHIA PA..... Noblit & Fassitt, cor. Broad and Cherry Sts.
- PITTSBURG PA..... Matheson Agency, 41 Leader Building
- BALTIMORE MD..... Matheson Co. of Maryland, 1002 Morton St.
- SAN FRANCISCO, CAL..... Matheson Co. of California, 442 Golden Gate Ave.
- ST. LOUIS, MO..... South Side Auto Co., 2339 S. Grand Ave.
- ALBANY N. Y..... Albany Garage Company, 28-30 Howard St.
- BINGHAMTON N. Y..... H. D. Clinton Auto Co.
- FORT WAYNE, IND..... Straus Bros & Company.
- MIDDLETOWN, N. Y..... Empire Garage Company.
- PORTLAND, ORE..... H. L. Keats Auto Company, 80-82 Seventh St.
- ROCHESTER, N. Y..... Rochester Automobile Company.
- WILLIAMSPORT PA..... Rothfuss-Howard Iron Works.
- LONG BRANCH, N. J..... Long Branch Auto Co.

Dealers are wanted in all localities where we are not now represented

## Matheson Motor Car Co. Makers

Main Office and Factory, WILKES-BARRE, PA.  
(Licensed Under Selden Patent)

THE POWERFUL  
*Grout*

## CARS

The very best as regards material, precision of manufacture, low investment and upkeep

Powerful  
Speedy Reliable

SPLENDID HILL CLIMBERS

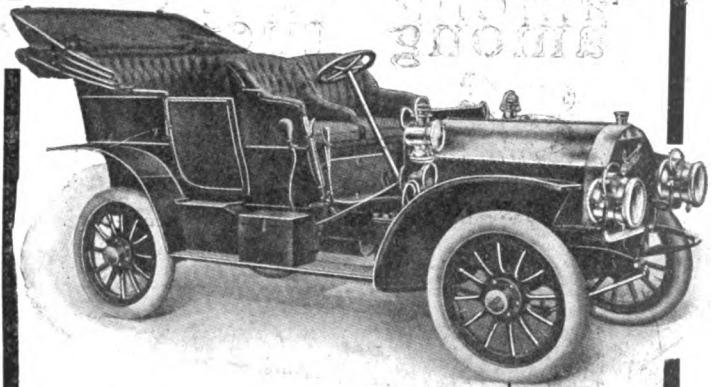

No lengthy argument is needed to convince you that the name "GROUT" is an absolute guarantee of sterling worth, but we would ask you to investigate the "Grout" before you decide on any other car. The more particular, the more critical you are, the more likely you are to decide in favor of the "Grout"—the car of HIGHEST GRADE.

Equipped in the best style, as shown above

4 Cylinder, 35 H. P.  
Complete with Top, Headlights and Generator

**\$2,500**

*We Invite Inquiry and Comparison*

**Grout Automobile Co.**  
Orange, Mass.

THE POWERFUL  
*Grout*



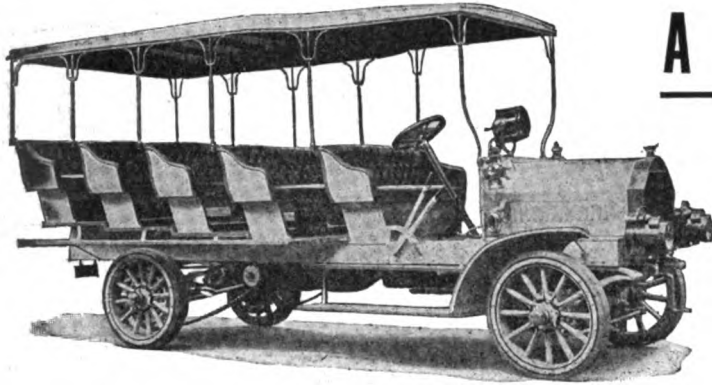

4-Cylinder, 35-40 H.P., 20 Passenger Sight Seeing Car.

## A RELIABLE COMMERCIAL CAR

Must always be Ready for Business. 10 hours a day and 300 days a year. Anything less is a failure. Our cars will never disappoint you.

**Auto Car Equipment Company, Manufacturers**  
87 EDWARD STREET, BUFFALO, NEW YORK

A car that has *quietly* taken its place among the leaders. The reliable

*Studebaker*

General Office

CLEVELAND, OHIO

Factory at

SOUTH BEND, IND.

# APPERSON CONSTRUCTION

In the building of "Famous Apperson Cars" no freak ideas are incorporated. Their universal supremacy is due to the employment of correct mechanical designs and ideas that have been developed by practical automobile mechanics and engineers during the fifteen years that the Apperson Bros. have been solely engaged in developing and building high grade motor cars. Apperson Bros. have had more experience in this line of manufacture than any other builder in America. In motor car construction it is experience that counts.

Dealers should investigate our New Model O which will sell at a low price.

**APPERSON BROS. AUTOMOBILE CO., KOKOMO, INDIANA**



# GEARLESS "GREAT SIX"

MODEL 75 — 75 H. P.—PRICE, \$4,000

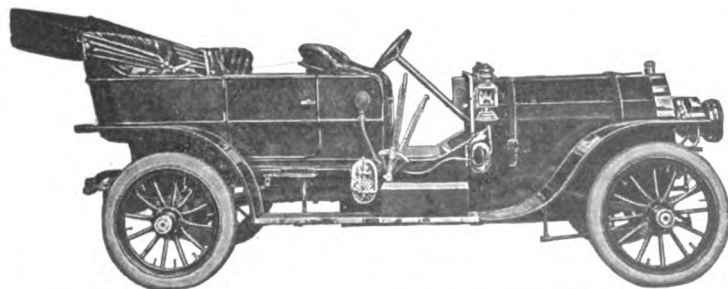

This car combines tremendous power, grace, elegance and superb finish. The beautiful, roomy, straight line body—a distinctive feature of Gearless Touring Cars, widely copied during the past year—comfortably seats seven passengers.

No appointment tending to comfort and convenience is lacking. Write for Catalog

AGENTS WANTED IN UNOCCUPIED TERRITORY

**GEARLESS MOTOR CAR CO.**

(Motor Car Dept.)

295 PLYMOUTH AVE., ROCHESTER, N. Y.

If you want good tire service and are not getting it;

Or, if you believe it possible to reduce your present yearly tire bill—

A comparative test of

# MORGAN & WRIGHT TIRES

on the same car with other brands, will satisfy you that such a result can be had—and without any extra cost over the price you pay for other tires.

☛ You can't do a better thing than to "try them out."

**MORGAN & WRIGHT, Detroit**  
Branches, Agencies or Dealers Everywhere

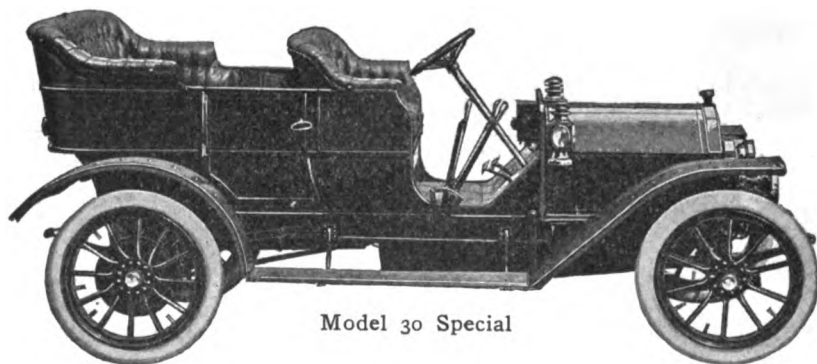

Model 30 Special

## PREMIER

The Car of Standard Practices Par Excellence

We confidently assert that point for point and as a whole the Premier car bears favorable comparison with any car of relatively equal horse-power and size, foreign or American, at any price.

Send for Catalog T

**PREMIER MOTOR MFG. CO.**  
INDIANAPOLIS, INDIANA, U. S. A.  
MEMBERS A. M. C. M. A.

TOURING CARS

\$ 3000.

ROADSTERS

# M

# OO

# N

**MOTOR CAR CO. St. Louis**  
**JOSEPH W. MOON PRES.**

# READVILLE

Gave 5 of 6 Events to

## Diamond

### WRAPPED TREAD TIRES

THE BEST CASINGS

THE BEST TUBES

INCLUDING

20-mile Track Record  
Special 20-mile Race  
Five-mile Handicap

THE DIAMOND RUBBER COMPANY Akron, Ohio

# KISSEL KAR

SAVES A  
Thousand  
Dollars

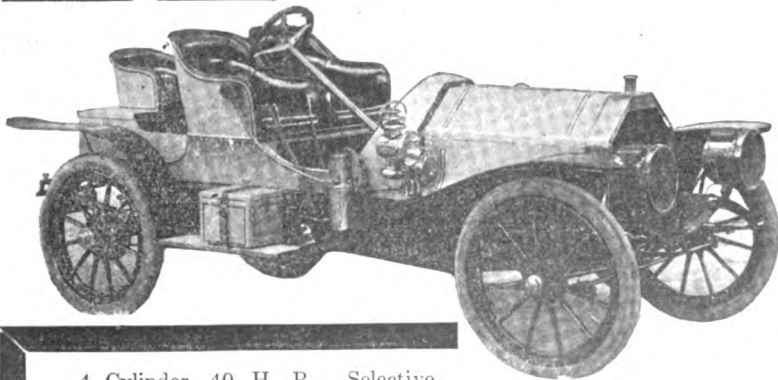

4 Cylinder, 40 H. P. Selective  
Type Transmission. Timken Roller  
Bearings. Floating Type Rear Axle.

The Kessel Kar represents maximum ability per horsepower, which means that the power is so rightly applied—that the mechanism is so correctly designed—that the maximum energy generated in your motors is transformed into **moving power** for your machine—into speed—hill climbing power—and ability to master hard, difficult roads.

Every ounce of the Kessel Kar's 40 H. P. counts—that's the secret.

Compare the Kessel Kar with the specifications of the higher priced car. They are the same. Yet the Kessel Kar costs \$2,000—from \$1,500 to \$1,000 less. Isn't that enough to make it worth while to write for a catalogue and investigate? **Roadsters and touring cars, \$2,000.** Write for catalogue.

Kessel Motor Car  
Company

HARTFORD, WISCONSIN

# The First Real Improvement

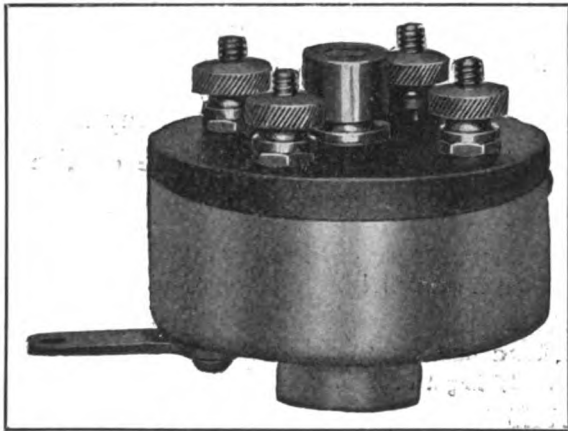

## In Ignition Timers

A three point roller bearing timer that embodies the one marked advance in ignition regulation

**Simple—Compact—Reliable**

No loose parts or delicate adjustments to become disarranged or wear, thus throwing out the perfect synchronizing of the several cylinders.

Write for full description and dealers discounts. Price each \$5.

FACTORY SALES CORPORATION, 237 RANDOLPH STREET, CHICAGO

Estab'd  
1876

**EXCELSIOR SUPPLY CO.**  
233-235 Randolph Street, CHICAGO, ILLINOIS

Estab'd  
1876

General Distributors

## "You Screw The Battery In—We've Done The Rest."

(BATTERIES SCREW IN LIKE AN INCANDESCENT LAMP INTO SOCKET.)

*The OLD  
Troublesome  
WAY!*



\$6.<sup>50</sup>

\$15.<sup>00</sup>

AND UPWARDS.

BE SURE YOUR  
CAR IS FITTED  
UP WITH A  
**WIRELESS  
HOLDER**

Made also in 8, 12 and 16 Cell  
Capacity.

PATENTED  
UNITED STATES AND  
FOREIGN COUNTRIES  
OTHER PATENTS  
PENDING



POSITIVE CONNECTIONS THAT CAN'T JAR LOOSE. EXHAUSTED CELLS can be removed without interrupting the Sparking Circuit—Cells cannot be connected up wrong even by a child. All Standard Dry Cells made to fit Holder, which is absolutely waterproof. Send for BULLETIN "A."

**STANLEY & PATTERSON, Sole Mfrs.**  
At all Dealers 23 Murray--27 Warren Sts., N. Y., U. S. A.

*The NEW  
EASY WAY!*  
At all Dealers

# PATTERSON WIRELESS BATTERY HOLDER



# Stevens-Duryea Sixes Again Victorious

In the Hill Climbing Contest held by the Albany Automobile Club, May 23d, The Big 6 Touring Car with 7-Passenger Body, made the best time of the day of all cars—53½ seconds.

In the 6th Event for 6-cylinder cars  
**STEVENS-DURYEA Ran First, Second and Third**  
Time: Big 6, 55 seconds; Light 6, 1.01<sup>3</sup>/<sub>5</sub>; Light 6, 1.10.

In the FREE-FOR-ALL  
**STEVENS-DURYEA Ran First, Second and Third**  
Time: Big 6, 53½ seconds; Light 6, 1.02; Light 6, 1.09.

**OF EIGHTY ENTRIES**  
The Light 6 Touring Car With 5-Passenger Body Made The Best Time of The Day for Touring Cars (with the exception of Big 6 Stevens-Duryea)—1.01<sup>3</sup>/<sub>5</sub>.

REMARKABLE RECORD BY REMARKABLE CAR.  
WRITE FOR SIX-CYLINDER LITERATURE.

## STEVENS-DURYEA CO.

900 MAIN ST.  
CHICOPEE FALLS, MASS.  
MEMBER A. L. A. M.

### One Accident Here—

Would mean a repair bill that would cost more than Prest-O-Lite would cost in ten years. One hard jolt, breaking a spring, would be enough to prove that Prest-O-Lite is not expensive.

Yet some people are constantly risking life and property, groping in the dark, tinkering with a gas generator, ruining their lamps, soiling their clothes, losing their temper, getting treacherous light all the time and often no light at all—

Trying to save two or three dollars a year, and not succeeding at that.

Over 40,000 motorists know that there is



no cheaper light, no cheaper insurance, than you get with a Prest-O-Lite gas tank.

A flood of steady, white, dependable light, turned on and off like a gas jet. Supplies two ¼-foot burners for 60 to 200 hours, depending on size of tank. Simply exchange an empty tank (dial shows when) for a full one.

### CAUTION:

When exchanging an empty tank, don't let anyone sting you with an imitation that can't be refilled promptly or can't be sold at a good price.

**Prest-O-Lite**  
Gas Tank THE NEW SIZE "E" **\$20**

### THE PREST-O-LITE CO.

Write the nearest main station.  
New York ..... 1904 Broadway  
Boston ..... 607 Boylston St.  
Indianapolis ..... 229 E. South St.  
San Francisco ..... Point Richmond  
Toronto ..... 6 King St. W.

1600 Refilling Stations.

**Always Look  
at the  
Name-Plate.**

## 120 Miles An Hour With Bosch Magneto

**N**AZZARO driving a 175 "horse" Fiat on the Brooklands Automobile Track, London, England, traveled two and three-quarter miles at the rate of 120 miles an hour. This is without question the most wonderful speed demonstration known to the world.

Perfect ignition was largely responsible for the placing of this new record. Naturally the BOSCH MAGNETO was used. The better class of motor cars all over the world are equipped with the Bosch System of Ignition.

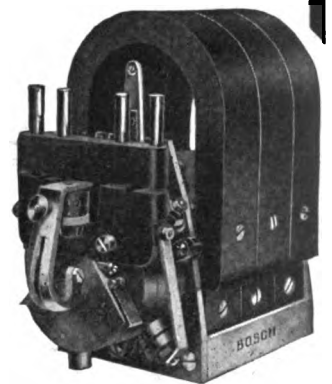

**Bosch Magneto Co., 160 W. 56th St., N. Y.**

## BRILLIANT RECORDS OF VARIOUS TIRES

are always interesting. But not so interesting to *you* as the genuine assurance that the tires you buy shall be the kind that make the records good. Our unequalled factory efficiency makes impossible a single flaw in the entire output of

## PENNSYLVANIA Clincher Tires

How we alone have achieved this, we tell in detail in "*Factory Facts*," our new book. Write for it and *read* it.



**PENNSYLVANIA RUBBER COMPANY**  
JEANNETTE, PA.

**BUFFALO:** 717 Main Street  
**DETROIT:** 237 Jefferson Avenue  
**SAN FRANCISCO:** 512 Mission St.  
**NEW YORK:** 1741 Broadway

**CLEVELAND:** 2134-6 East Ninth St.  
**CHICAGO:** 1241 Michigan Avenue  
**BOSTON:** 167 Oliver Street

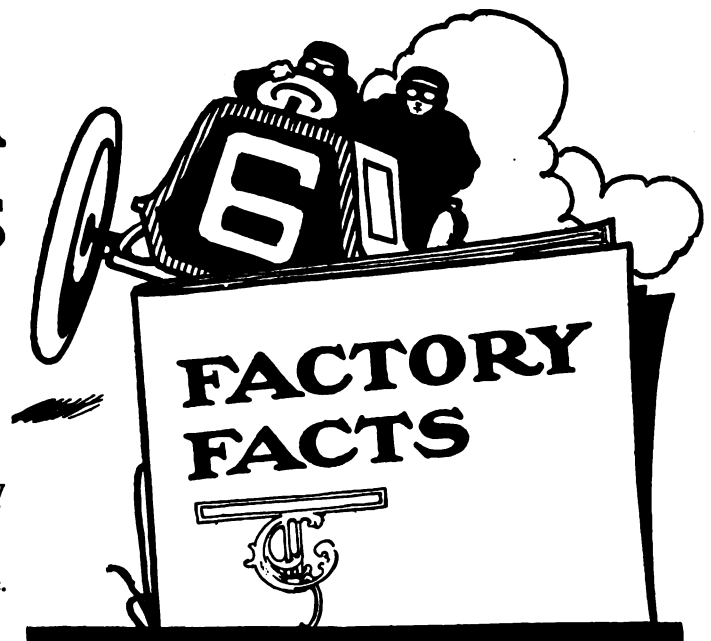

# Camps of Short Range

throw a brilliant glare on the road close to the car, but they defeat their own object by doing so, since the driver's eyes are partially dazzled, and he cannot see clearly past the brightly lighted area to the fainter illumination beyond.

For high speed and safety, it is essential that the projected beams shall not strike the road too close to the car. It is also essential that they shall not scatter. The ideal equipment

for a touring car of medium power, is a pair of 9-inch Rushmore Headlights with their burners set slightly out of focus to spread the rays, and a 10-inch Rushmore Searchlight on the dashboard, with its burner set exactly in focus, for the longest possible range. The searchlight not only enables one to see what he is turning into, but supplements the headlights by adding its more concentrated and longer beam to those of the latter. With such an equipment one can see the road perfectly for from 100 to 200 yards, depending on its color, and guesswork is entirely eliminated.

The best article in any field sets the standard for its kind. For eight years, Rushmores have set the pace in automobile lamps, and today they are still the most powerful and most durable in the world.



A stone wall and hill. The car is equipped with Rushmore Headlights, Searchlight and Generator.

**RUSHMORE DYNAMO WORKS** PLAINFIELD, N. J., U.S.A.—  
LONDON, PARIS, CHICAGO

## OVERLAND VICTORIES

Overland cars do not have to rely on past performances. Each event in which they are entered adds to their list of victories. The following list of recent events should interest every intending purchaser:

**Indianapolis Hill Climb, March 24, '08..... First Prize**  
**Fort George Hill Climb, April 9, '08..... Second Prize**  
**Indiana Reliability Run, May 20, '08..... Perfect Score**  
**Cincinnati Hill Climb, May 3, '08..... Second Prize**  
**Bridgeport, Conn., May 3, '08..... First and Second**  
**Williamsport, Pa., June 6, '08..... Two Firsts**

You take no chances when you buy the OVERLAND. Every car is built right to the smallest details. 20-22 h.p., 4-cylinder, shaft drive, 96-inch wheel base, full elliptic springs, transmission and differential in one housing on rear axle, NO SIDE LEVERS. Write for catalogue.

**AMERICAN MOTOR CAR SALES COMPANY**

FACTORY SALES AGENTS FOR AMERICAN, MARION AND OVERLAND CARS

**INDIANAPOLIS, IND.**

# The Auto-Meter Is Believed

Talk about speed indicators that are believed—that have figured largely in famous events! Here are a few right off the reel—just jotted down from memory! The reviewing of big motor events is nothing more or less than a history of the successful career of the Auto-Meter.

Glidden Tour, 1906, 38 Warner Auto-Meters used; all other makes, 23. Memorial Day Races, Denver, 1906, Thomas "40" won 1st; Stevens-Duryea, 2nd; both Warner-equipped.

Mudlark, 1906, from New York to Daytonia, Warner-equipped; big tour afterward.

Memorial Day, 1906, non-stop run, New York-Boston-Springfield, Knox Waterless made record, Warner-equipped.

Franklin Car, San Francisco-New York, 4500 mile run, August, 1906, Warner-equipped.

Percy Megargle with Reo Mountaineer, across continent and back, 12,000 miles, 1906, Warner-equipped.

Military Message Run, Chicago-New York, June, 1906, Buick car, Warner Auto-Meter.

Military Run, New York-San Francisco, Aug., 1906, a Warner was used.

Red Cloud, Olds, Trans-Continental Run, 1907, Warner equipped.

Glidden Tour, 1907, 75 cars started; 53 used Warners; 21 used other makes.

The fire departments of the following cities use the Auto-Meter: New York, Boston, Detroit, Chicago, Denver, Joplin, Mo., and Seattle, Wash.

All the reliable maps of the country have been laid out with Auto-Meters. The Blue Book, White's Route Book, all Canadian maps, Michael's Pictorial Maps, all Glidden Tour courses, King's Maps, Briarcliff Course, etc.

Nearly all the automobile makers of the country use the Auto-Meter to test their cars before leaving the factory.

The E. R. Thomas Motor Co. and the Olds Motor Car Co., furnish the Warner as part of the regular equipment.

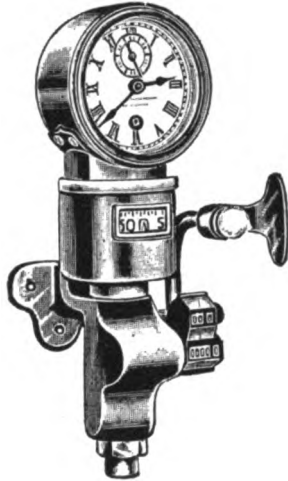

Detroit Reliability Run, 1907, winner used Warner.

New York-Chicago Sealed Bonnet-Contest winner Warner equipped.

Cleveland Pathfinder to Ormond, Warner-equipped.

Long Island Economy Run, Frayer-Miller winner, was Warner-equipped.

In New York-Paris Race only speed indicator in the run is a Warner Auto-Meter.

Ralph Owen, driver of Mudlark, 1908, bought a Warner for his car though offered another as a gift.

Winning Haynes car in Chicago Reliability Race, December, 1908, was Warner-equipped.

Charles J. Glidden, has piled up 42,367 miles in 35 countries with a Warner Auto-Meter.

**Warner Instrument Co., 209 Wheeler Ave., Beloit, Wisconsin**

## The Severest Tests

have demonstrated time and time again that the principles employed in

## Timken Roller Bearings

are the only correct ones that insure perfect transmission of all power to traction use, eliminating both friction load and end thrust.

A Stoddard Dayton Stock Car equipped complete with **Timken Roller Bearings** finished April 12th, a ten-day century run, 1,000 miles over the roughest roads with all adjustments sealed, something impossible for a car equipped with the ordinary type of bearings to perform.

This car, as are all cars of the **Stoddard Dayton** make, carries a full equipment of **Timken Roller Bearings**, as tests made under the most adverse and severe conditions have proven them an economical factor in the saving in wear and tear from strain alone.

And these are some of the reasons why more than **65 per cent.** of all the makers of high grade American Automobiles and over **90 per cent.** of the Commercial Truck builders are now using them.

Are you? If not, won't you let us give you some figures that prove? These are yours for the asking.



**The Timken Roller Bearing Axle Co., - Canton, Ohio**

Branches: 10 E. 31st Street, New York. 429 Wabash Avenue, Chicago



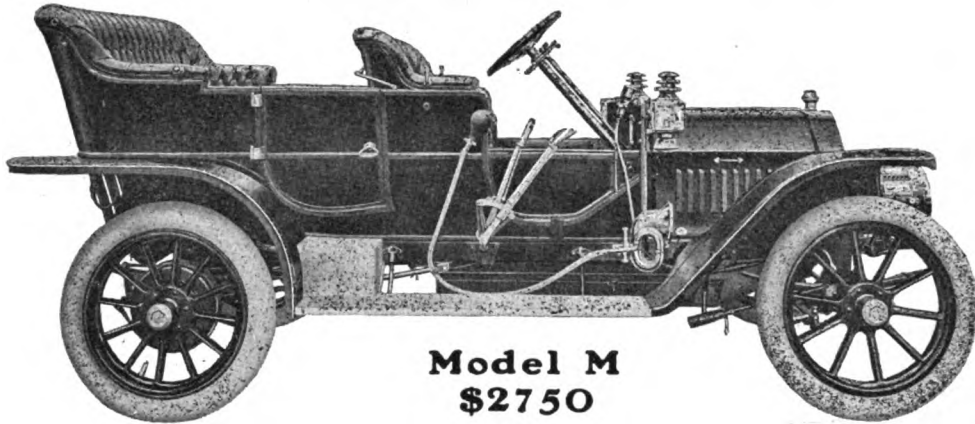

**Model M**  
**\$2750**

## OLDSMOBILE

Model M is distinctly a superb family car—Powerful, Speedy and above all, Comfortable. It meets the requirements of the buyer who desires a car that will give service year in and year out without the burden of excessive repairs or up-keep. Other models, four and six cylindered, \$2,000 to \$4,200.

The 1908 catalog is an encyclopedia of motor car information, especially written for the man who would know the car in which he invests. It is mailed free on request. Address Dept. A.

**OLDS MOTOR WORKS, Lansing, Michigan, U. S. A.**

**MEMBERS A. L. A. M.**

Canadian trade supplied by the Oldsmobile Co. of Canada, Toronto, Ontario.

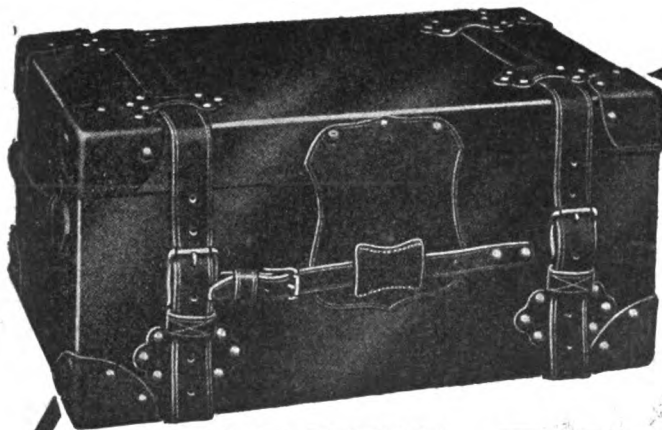

## FOR THE TOURIST

who desires "all the comforts of home" en route, a John Boyle Trunk is a necessary equipment—affords ample accommodation for anything he or she may wish to carry—every requirement of toilet and dress and other necessities in one roomy, safe, sure—under lock and key—water-proof and dust-proof trunk, strapped out of your way at the rear of the car. Easily opened en route. At your destination unstrap from car and send into your rooms. Gives pleasure, comfort and satisfaction to all tours; you know you are ready for any emergency regardless of weather changes or stop-overs en-tour.

## JOHN BOYLE TRUNKS

are light — compact — capacious — accessible — inexpensive — reliable — weather-proof — dust-proof and indestructible, and present a handsome appearance. They are built with especial view to the use intended and are strong to withstand the roughest usage, yet light to avoid overweighting the car. Their Quality and Price make them the most inexpensive you can buy.

*Write for Style Book and Prices for the various makes of cars*

**JOHN BOYLE & CO.**

112-114 Duane St. NEW YORK 70-72 Reade St.

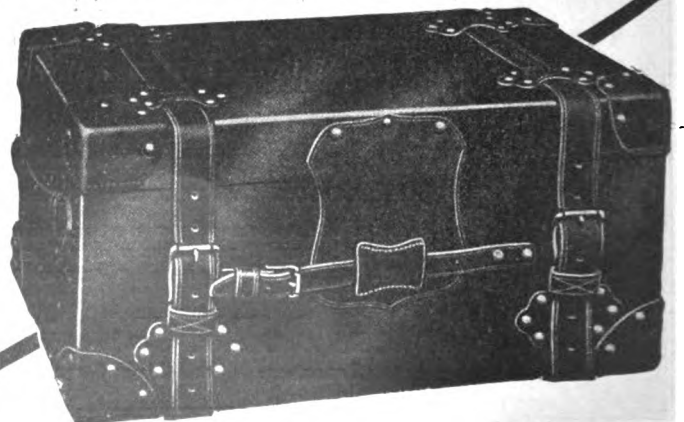

# FRANKLIN Automobiles

“Why don't more manufacturers build air-cooled automobiles?”

Last winter in Chicago the air-cooled Franklin Type D, a five-passenger automobile, ran idle a week continuously in a warm salesroom. Other Franklins of the same type ran idle indoors in Philadelphia 24 hours; in Washington, 60 hours; in Baltimore, 72 hours. At Cincinnati a Type D ran on the road and in the salesroom 440 hours without stopping.

No water-cooled motor can run idle under its own cooling system. The Automobile Club of America in making its dynamometer tests on water-cooled automobiles had to rig a powerful extra fan to prevent their overheating.

In all the water-cooled automobiles yet built the hot dead gas of the explosion is held in the cylinder until the end of the exhaust-stroke. The Franklin auxiliary exhaust gets rid of this useless heat immediately after the explosion.

Franklin air-cooling has nothing to steam or boil; nothing to freeze in winter. It gets more work out of the fuel. It gets rid of complicated apparatus and trouble and bother. It gets rid of useless weight.

This gives more ability for the power. It saves gasoline and tires. It lessens the wear and tear.

A light automobile does not strain and rack itself on the road as much as a heavy one. All this brings down owning-cost and depreciation-cost.

You can't build a water-cooled automobile as efficient and able as an air-cooled one; nor as economical. Yet you often hear the question “If air-cooling is a success why don't more manufacturers build air-cooled automobiles?”

The answer is: Successful air-cooling is possible only through experience and inventive skill. We have been developing the Franklin steadily along the same line for six years. But anybody can build a water-cooled motor.

Why are there no more turbine steamships? Of all the great ocean liners only three have turbine engines—but they are the latest and finest ships; and they hold the trans-Atlantic records.

The air-cooled Franklin is the only automobile that was ever able to run from San Francisco to New York in 15 days; or from Chicago to New York in less than 40 hours. No stock automobile but a Franklin ever ran 50 miles in 57 minutes 43 seconds.

Automobile users are learning the facts, Franklin sales have increased 40 per cent even in this “off” year when automobile sales generally are away below normal.

Manufacturers are beginning to realize that only the fittest will survive. More of them would build air-cooled automobiles if they could.

They will when they learn how

Write for the Franklin catalogue

16 h.p. 4-cylinder Runabout, \$1750 | 28 h.p. 4-cylinder Touring-car or Runabout, \$2850  
16 h.p. 4-cylinder Touring-car, \$1850 | 42 h.p. 6-cylinder Touring-car or Runabout, \$4000

Prices f. o. b. Syracuse.

H. H. FRANKLIN MFG. CO. Syracuse, N. Y.

# Are You Quite Satisfied?

IMPORTED  
DIE-  
FORGINGS

CHROME NICKEL STEEL!  
CHROME VANADIUM STEEL!  
SPECIAL AUTO STEEL!

FOR ALL  
AUTOMOBILE  
PARTS

COST LESS THAN CASTINGS IN THE FIRST PLACE!

ROUND  
BARS  
ALL  
SIZES

CHROME NICKEL STEEL!  
CHROME VANADIUM STEEL!  
SPECIAL AUTO STEEL!  
SPECIAL GEAR STEEL!

MILL LENGTHS  
OR CUT OFF  
TO SUIT  
PURCHASERS

DO NOT HANDLE INFERIOR STEEL AT ALL!

DESIGNS  
AND  
DRAWINGS

OF MOTORS, TRANSMISSIONS  
CHASSIS  
OR OF OTHER PARTS OF CARS

MADE  
TO  
ORDER

AT A FIXED PRICE FOR GUARANTEED WORK!

EXPERT  
ATTENTION  
GIVEN

TO THE INVESTIGATION OF  
AUTOMOBILES, THEIR  
MATERIALS OR QUALITY

FEARLESS  
HONEST  
OPINION

A STITCH IN TIME SAVES NINE!

## J. M. ELLSWORTH,

*Automobile Engineer,*  
30 Pine Street,  
NEW YORK

# Rambler

MODEL 248

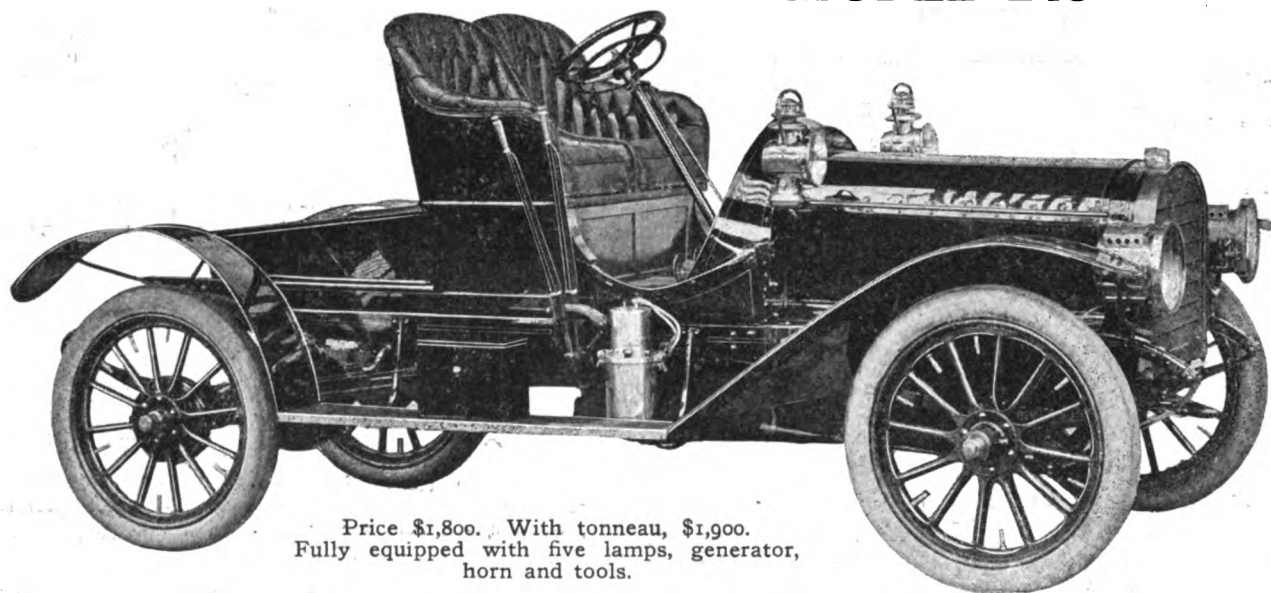

Price \$1,800. With tonneau, \$1,900.  
Fully equipped with five lamps, generator,  
horn and tools.

## HERE IS AN UNUSUAL CAR

**F**OUR cylinders—full 30 horse power—adjustable roller bearing transmission—transmission gears made of special steel that will neither mar nor chip; floating type rear axle; full elliptic rear springs.

With tonneau, a complete touring car; full size; five passenger capacity; 108-inch wheel base; 34-inch wheels and 4-inch tires.

Quiet, powerful, flexible and handsome.

Tested by three seasons continuous service and perfected by the knowledge gained from twelve thousand Ramblers in daily use.

Where else can you obtain similar value—size, power, efficiency, reliability, appearance and comfort?

Write to-day for the special 248 page catalog and complete particulars.

### THOMAS B. JEFFERY & COMPANY

Main Office and Factory, KENOSHA, WIS.

Branches and Distributing Agencies:

CHICAGO

MILWAUKEE

BOSTON

PHILADELPHIA

SAN FRANCISCO



# WHITE WINS

## A Partial Summary of Victories, May, 1907-May, 1908

### PERFECT SCORE IN HARRISBURG ENDURANCE RUN

Tying with three other cars in the contest of May 5th-6th, 1907. For the result of the "run-off," see below.

### FASTEST TIME IN WILKES-BARRE HILL-CLIMB

Defeating 45 high-powered gasoline cars, in the great contest on Decoration Day, 1907.

### FASTEST TIME IN CLEVELAND HILL-CLIMB

Defeating 40 high-powered gasoline cars.

### FASTEST TIME IN CALIFORNIA HILL-CLIMB

Defeating the fastest of its gasoline competitors by nearly two minutes on the 2 7-8 mile hill at Witter.

### PERFECT SCORES IN SEALED BONNET CONTEST

Both White cars entered made perfect scores in this contest conducted by the Automobile Club of America.

### OFFICIALLY OBSERVED NON-STOP RUN OF 1871 MILES

Held under the auspices of the Royal Automobile Club of England and certified by that organization.

### FASTEST TIME OF THE SEASON ON THE TRACK

One mile in 1:02, ten miles in 12:54 and twenty-five miles in 29:07 at the Santa Rosa Track Meet.

### OFFICIALLY DECLARED MOST EFFICIENT CAR

In the South Harting hill-climb, conducted by the Royal Automobile Club, the White won the contest because it developed at the rear wheels a greater percentage of its assigned horse-power than did any other car. The rating assigned to the White was 50 horse-power.

### WINS ENGLISH DUST TRIALS

Proving officially that it raises less dust than any other car.

### CLEAN SWEEP IN THE GLIDDEN TOUR

Three White entries make three perfect scores.

### WON HOWER TROPHY

The single White runabout entered in the Glidden Tour defeated a dozen high-priced gasoline runabouts competing for this prize.

### WON CALIFORNIA RELIABILITY CONTEST

In the original contest held September 20th, two Whites tied with two gasoline cars. In the "run-off" held November 15th and 16th, both Whites made perfect scores while both gasoline cars were penalized.

### WON QUAKER CITY ENDURANCE RUN

In this contest, held January 1st, 2d and 5th, the White vanquished 27 gasoline cars of 23 leading makes, winning the MacDonald & Campbell trophy.

### FASTEST TIME IN SAN FRANCISCO HILL-CLIMB

Winning the free-for-all, the \$2,500 class and the \$3,500 class.

### FASTEST TIME IN THE NEW YORK CARNIVAL HILL-CLIMB

Making the ascent of Fort George hill in 32 1-5 seconds, compared with the best gasoline time of 36 seconds; largest entry list of any hill-climb ever held.

### NEW SAN FRANCISCO - LOS ANGELES RECORD

The White car made the 478-mile mountainous journey in 17 hours and 17 minutes, cutting 56 minutes from the previous figures.

### DOUBLE VICTORY IN HARRISBURG ENDURANCE RUN

The single White entry was the only touring car to make a perfect score, winning the principal 1908 trophy, the Board of Trade Cup, and also the 1907 prize in a "run-off" with last year's other perfect-score drivers.

### PERFECT SCORE IN DETROIT ENDURANCE RUN

### PERFECT SCORE IN BALTIMORE SEALED MECHANISM CONTEST

### TWO PERFECT SCORES IN KANSAS CITY RELIABILITY RUN

WRITE FOR LITERATURE

## THE WHITE COMPANY

CLEVELAND, OHIO

NEW YORK CITY, Broadway at 62d Street  
SAN FRANCISCO, 1460 Market Street  
PHILADELPHIA, 629-33 North Broad Street

PITTSBURG, 138-148 Beatty St.

BOSTON, 320 Newbury Street  
CHICAGO, 240 Michigan Avenue  
CLEVELAND, 407 Rockwell Avenue



# THE 1909

*Packard*  
"THIRTY"

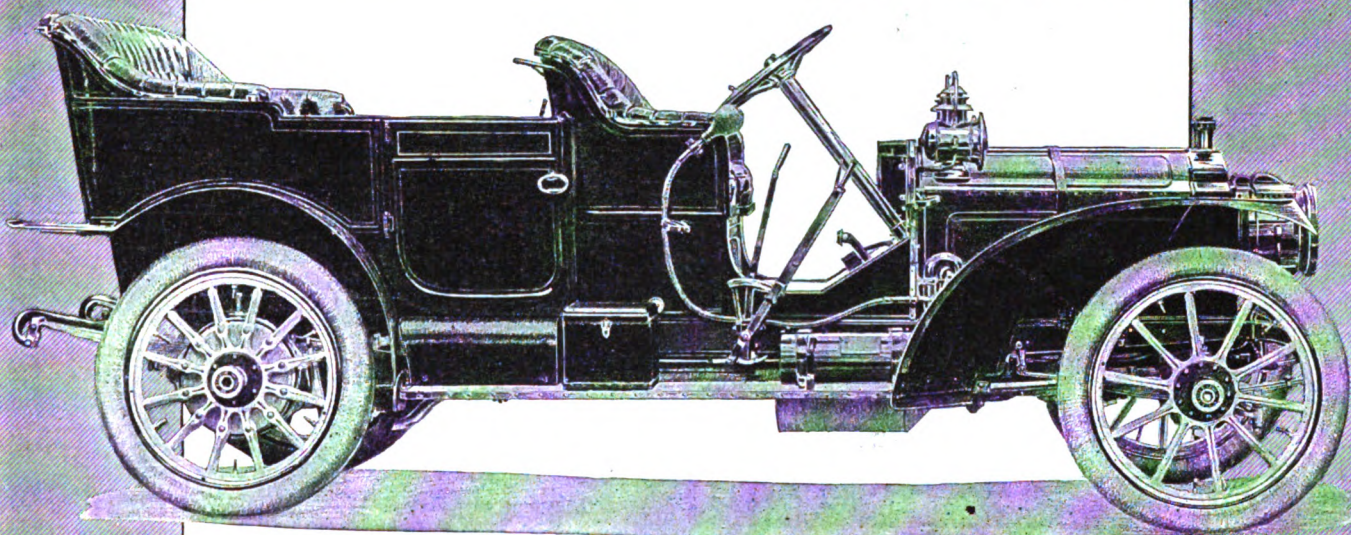

Touring Car, in Standard Finish  
and Equipment, \$4,200

Touring Car — Landaulet  
Limousine — Runabout  
Other Bodies — Chassis

Manufactured Entirely  
in the Packard Shops

"Ask the man who owns one"

Packard Motor Car Company  
Detroit, Michigan





# "SCHEBLER"

"The Big Noise"  
of the Carbureter Band

Imitated but never equalled

Used and endorsed by satisfied autoists everywhere. Universally acknowledged by the one hundred and thirty thousand users who have put it to a practical test that the

## SCHEBLER CARBURETER

has ample justification for its pre-eminent position as "The Standard of the World."

Our aim in designing the "Schebler" was greatest **Efficiency, Economy and Durability**, and in these qualities the Schebler excels.

It supplies a uniform mixture regardless of rough roads, engine speeds or atmospheric conditions. The "Schebler" Carbureter is **always** reliable, and increases the power of your engine 20 to 30 per cent.

Is it on your car—if not, why not?

You should have our literature. May we send it? A postal will do.

### WHEELER & SCHEBLER, Manufacturers, Indianapolis, Ind.

SALES OFFICES:  
F. J. ALVIN, MANAGER  
233-237 Randolph St., Chicago

NEW ENGLAND OFFICE:  
W. J. CONNELL, MANAGER  
36 Columbus Ave., Boston, Mass.

EASTERN OFFICE:  
E. J. EDMOND, MANAGER  
The Motor Mart, 62d and Broadway, N. Y.

CANADIAN OFFICE:  
MILLEN & SONS, Ltd.  
Montreal, Vancouver, Toronto.

#### LIST OF DISTRIBUTERS

Eugene Arnstein, 35th & Shields Ave., Chicago, Ill.  
Excelsior Supply Co., 235 Randolph St., Chicago, Ill.  
Beckley-Ralston Co., Chicago, Ill.  
The Kelsey Co., 43-45 Niagara St., Buffalo, N. Y.  
Chas. E. Miller, 824 Main St., Buffalo, N. Y.  
Pierson Motor Supply Co., 1175 Bedford Ave., Brooklyn, N. Y.  
National Electrical Supply Co., 1330 New York Ave., Washington, D. C.  
Jos. Woodwell Co., 201 Wood St., Cor. 2d Ave., Pittsburg, Pa.  
Chas. S. Smith & Co., 302 Broad St., Philadelphia, Pa.  
Autolight & Motor Supply Co., 508 N. Broad St., Philadelphia, Pa.  
Bay State Machine Co., Erie, Pa.  
Wallace Bros., Norfolk, Va.  
J. W. Lathrop & Co., Mystic, Conn.  
G. D. Thorndike, Portland, Me.  
Jas. Bailer Co., Portland, Me.  
Angier Co., 9-11 Dorrance St., Providence, R. I.

Neustadt Auto & Supply Co., 3948-54 Olive St., St. Louis, Mo.  
Kansas City Motor Supply Co., Kansas City, Mo.  
C. J. Smith & Co., 16 W. 4th St., St. Paul, Minn.  
Northern Electric Co., Minneapolis, Minn.  
Angier Co., 745 Boylston St., Boston, Mass.  
Auto Supply Co., 14 Columbus Ave., Boston, Mass.  
Boston Cycle & Sundry Co., 48 Hanover St., Boston, Mass.  
Gordon's Auto Supply Co., Elliot St., Boston, Mass.  
Florida Gas Engine & Supply Co., Tampa, Fla.  
A. Baldwin & Co., Cor. Camp & Common Sts., New Orleans, La.  
Walte Auto Supply Co., Providence, R. I.  
Belcher & Loomis Hdw. Co., Providence, R. I.  
Chanslor & Lyon Motor Supply Co., 542-6 Golden Gate Ave., San Francisco, Cal.  
Chanslor & Lyon Motor Supply Co., 930 S. Main St., Los Angeles, Cal.  
Powell Automobile Co., 2010 Farnam St., Omaha, Neb.  
Bailou & Wright, Portland, Ore.

Archer, Combs & Winters Co., 306 Oak St., Portland, Ore.  
Monarch Machine Co., Des Moines, Ia.  
Union Supply Co., Toledo, O.  
Coughlin & Davis, 8th & Walnut Sts., Cincinnati, O.  
DeMooy Bros., 1831-37 E. 55th St., Cleveland, O.  
Chas. E. Miller, 406 Erie St., Cleveland, O.  
H. T. Hearsey Vehicle Co., 113-117 West Michigan St., Indianapolis, Ind.  
Milwaukee Auto Engine & Supply Co., 706-8 Winnebago St., Milwaukee, Wis.  
Kilbourne & Clark Co., 307 First Ave., Seattle, Wash.  
John H. Thompson & Co., 206 Jefferson Ave., Detroit, Mich.  
Chas. E. Miller, 227 1-2 Jefferson Ave., Detroit, Mich.  
Denver Auto Goods Co., Denver, Col.  
Page Engineering Co., 119-121 E. York St., Baltimore, Md.  
Sidney B. Robey Co., Rochester, N. Y.

Ready for delivery  
July 1, 1908

# Chalmers-Detroit

*"It's a good car"*

A 4-cyl., 5-passenger, 24-30 h.p. car. Made by the makers of the Thomas-Detroit Forty.

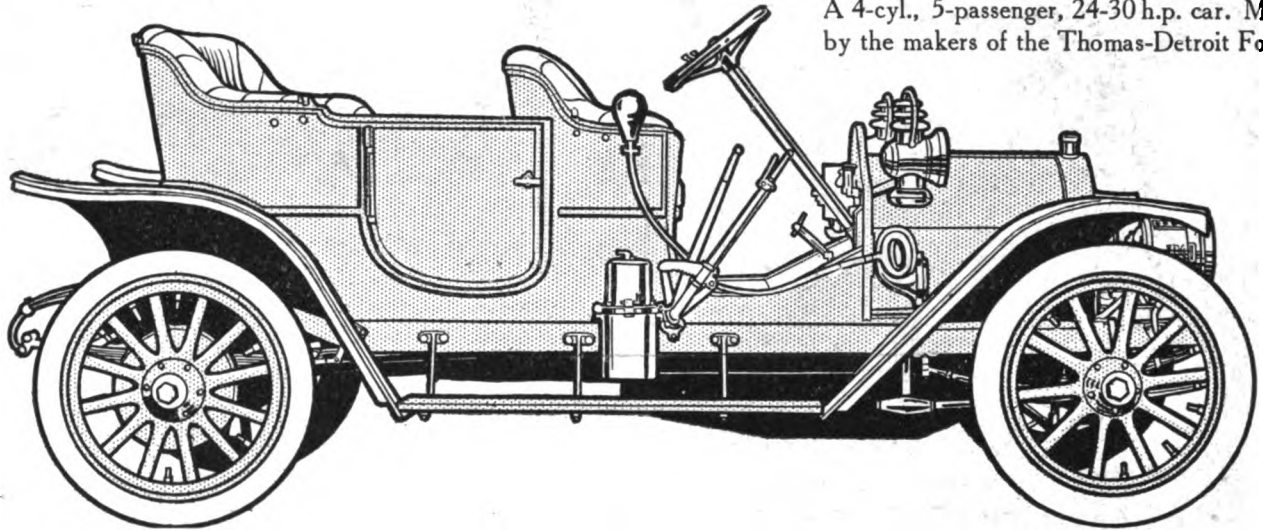

## This Astounding Car for \$1,500

**A millionaire's car brought by mammoth production down within reach of the many. Looks like the costliest cars—does all that the costliest do. Yet so low in price, so economical in upkeep, that fifty times as many people can now own a powerful, high-grade car.**

For two years—after we perfected the Thomas-Detroit Forty—we have worked to perfect this car.

Not to sell at \$1,500; for nobody dreamed, two years ago, that such a car could ever be sold for that. We simply aimed at perfection in a light-weight car—a car with low cost of upkeep. We expected the cost to run at least \$2,000.

But the panic last fall cut the prices of materials, and we are giving you the benefit of our ability to purchase ahead.

Note that this car is not an experiment—not a hasty makeshift. We have worked for over two years in perfecting it. Three of the new cars have been run over 7,000 miles.

Designed by Mr. H. E. Coffin, our vice-president, for years the chief designer of the Thomas Companies. He is recognized as the leading automobile designer in America.

Mr. Coffin made two trips to Europe, to combine in this car the best foreign features with the best American. He has thus made it the typical car of to-day.

The lines are handsome, yet conservative. The car follows, in this respect, the leading cars of the year. The finish and upholstery are the same as are found in cars costing double this price.

The wheel base is 110 inches—compare that with rival cars. We have only a 2-inch longer base in our \$2,750 car. The frame of the Chalmers-Detroit is exactly the same as in our Detroit-Forty.

Thus we give you a roomy and elegant five-passenger car—not a car that looks cheap because small.

Weight 2,000 pounds, which means a low tire cost, a low cost of upkeep. Power 24-30 h. p.—sufficient for any requirement. Speed 45 to 50 miles per hour.

Now let us compare the mechanical features with some high-priced cars.

The four cylinders are cast together, as in the latest Fiat, the Darracq, and a score of great foreign cars. Our factory cost on this engine alone is \$261. Yet 4-cylinder automobile engines are sold as low as \$75.

We use the Unit Power Plant, as in the new Decauville, the Motobloc and others. Motor, clutch and transmission form a single unit, so they cannot get out of alignment.

The body is suspended, for easy riding, after the style of the Mercedes. The valves are like those of the Napier. The  $\frac{1}{2}$  Elliptic Springs are like the Renault and others.

Low-priced cars are not new; there will be more this year than ever. Rivals may follow us with four-cylinder cars costing even less than this.

But the novelty lies in a car that you can take pride in—a large and luxurious car—a perfect and powerful car—selling at a price like this.

There we have no competition. Not a car selling within \$500 of our price can stand for a moment in actual comparison with the Chalmers-Detroit.

Ready for delivery July 1—catalogs ready now.

Selective sliding gear transmission; three speeds forward and reverse. Perfect dust protection.

As completely fitted with annular ball bearings as the Mercedes, Hotchkiss and Renault. Very few of the costliest American cars use so many. The actual cost of the ball bearings in this car is \$103.

Brakes heavier than we used, until this year, on our "Forty." Anti-backing device to protect you on hills. Double ignition system.

The lubrication system which is now used on the "Forty," and which is being adopted on all leading cars. A multiple disc clutch—similar to that used on the Isotta, Fiat and many others. The gas intake is water-jacketed to save you the trouble of a rising through cold gasoline.

Floating type rear axle, used heretofore only on the highest-priced cars. Wheels 32 inches; tires 32 inches.

So simple in control that a novice can master the car in ten minutes.

Compare these features, one by one, with the costliest cars. You will note we have stinted nowhere. We did not start out to make this a cheap car.

Then compare the same features with other low-priced cars, and you will see why we have no competition.

Please send us this coupon now for our catalog. The cars are almost ready. Our contracts for materials are only sufficient for 2,500 cars. After that the price must advance if materials advance. So please get the facts at once, so as to decide if you want one.

CHALMERS-DETROIT MOTOR CO.,  
2700 JEFFERSON AVE.,  
DETROIT, MICH.

Please send the catalog to

Name.....

Address.....

## Chalmers-Detroit Motor Co., Detroit, Mich.

HUGH CHALMERS, President

Successors to E. R. Thomas-Detroit Co.

Makers of the Thomas-Detroit Forty  
Now called the Chalmers-Detroit Forty

This change in name involves no change in ownership, personnel or management. It is simply made to avoid the confusion of two Thomas concerns operating on separate lines.



# WINTON

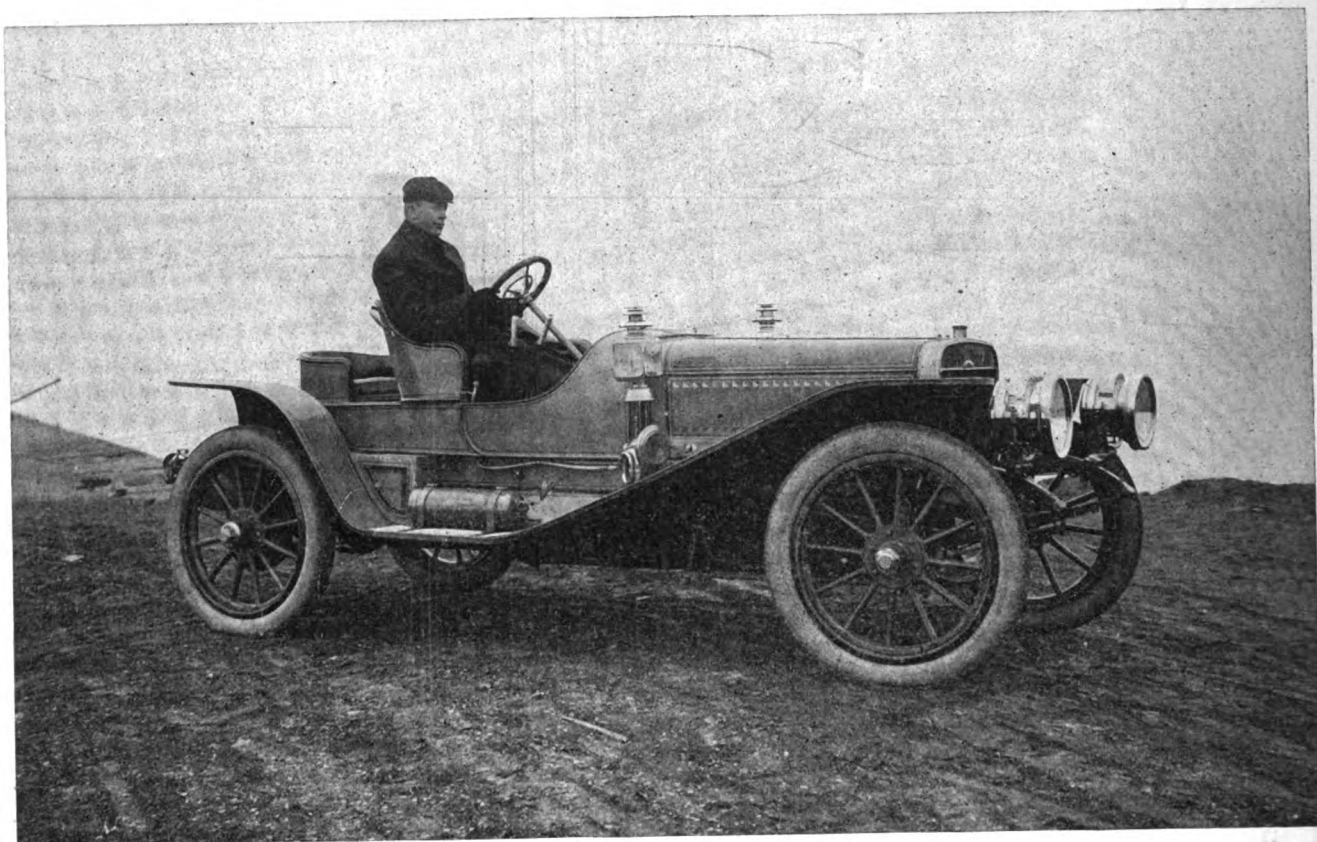

The Winton Six-Teen-Six runs all the time "like coasting down hill." Low motor speed for ordinary work, giving splendid reserve power for a brilliant burst of speed or a conquering hill-climb. Overlapped power strokes give constant tension on driving mechanism, eliminate jerks and shocks, and say good-bye to the repair bills and tire expenses that go with four-cylinder motor cars. Goes the route on top gear. Quiet engine—simple, and perfectly housed. Rides luxuriously. Plenty of room for seven. Starts from the seat on compressed air.

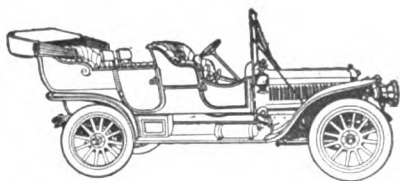

## The Winton Motor Carriage Co.

Member A. L. A. M.  
Cleveland, Ohio

### Branch Houses in

New York	San Francisco	Detroit
Chicago	Boston	Seattle
Pittsburg	Philadelphia	Baltimore



# STROMBERG CARBURETER

## FORMERLY KNOWN AS "THE GOLDBERG"

The name has been changed, but not the carbureter, which remains in each and every detail the same as heretofore.

**SAME  
GUARANTEE**

**SAME CARBURETER**

**SAME  
OFFER**

"We sell these carbureters under a positive guarantee as to material and workmanship, and any part or parts proving defective at any time will be repaired or replaced free of charge upon return of such part or parts to our factory. It is further guaranteed that this carbureter will operate satisfactorily upon your motor when properly installed and adjusted to the same, and if it does not, after a trial of 30 days, you have the privilege of returning it, when we will refund the purchase price."

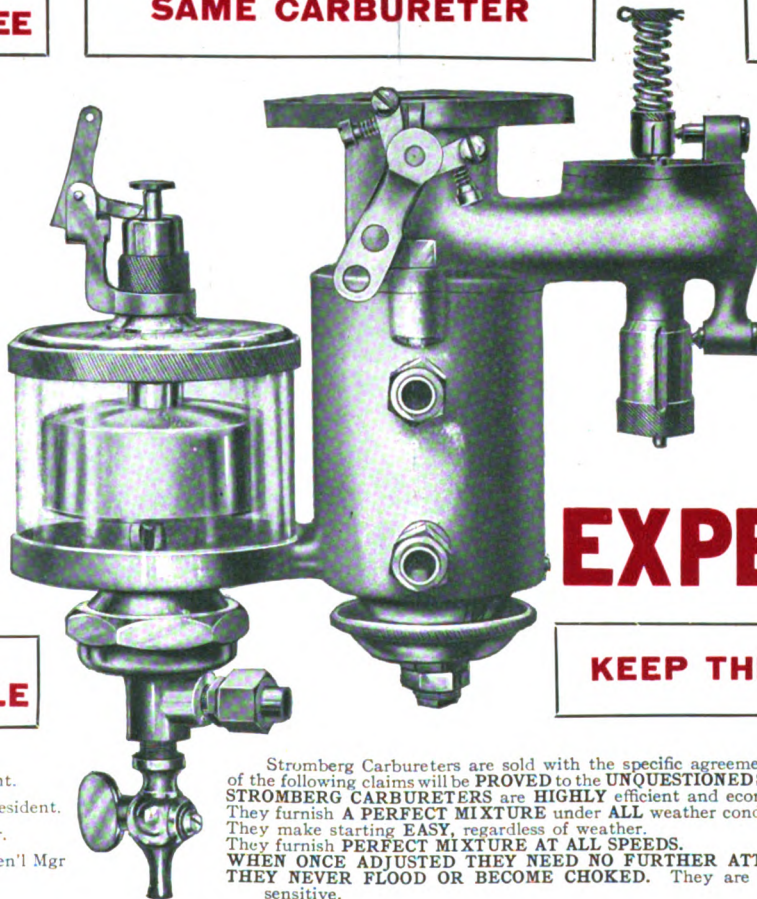

**"TRY  
ONE  
AT  
OUR  
EXPENSE"**

**SAME  
PEOPLE**

**KEEP THIS IN MIND**

Alfred Stromberg, President.  
John S. Goldberg, Vice-President.  
Andrew Carlson, Treasurer.  
Chas. W. Stiger, Sec'y & Gen'l Mgr  
Charles A. Brown.

Stromberg Carbureters are sold with the specific agreement that each and every one of the following claims will be **PROVED** to the **UNQUESTIONED SATISFACTION** of the buyer. **STROMBERG CARBURETERS** are **HIGHLY** efficient and economical. They furnish **A PERFECT MIXTURE** under **ALL** weather conditions. They make starting **EASY**, regardless of weather. They furnish **PERFECT MIXTURE AT ALL SPEEDS**. **WHEN ONCE ADJUSTED THEY NEED NO FURTHER ATTENTION!** **THEY NEVER FLOOD OR BECOME CHOKED.** They are **EXTREMELY** flexible and sensitive.

WRITE TO-DAY FOR CIRCULAR No. 1, WHICH ILLUSTRATES, EXPLAINS AND PROVES EVERY CLAIM.

## **STROMBERG MOTOR DEVICES CO.**

Successors to **GOLDBERG MOTOR CAR DEVICES MFG. CO.**, 1253-55 MICHIGAN AVENUE, CHICAGO.

**Eastern Branch**

241-242 Thoroughfare Building,  
58th St. and B'way, New York City  
C. S. GIBSON, Manager.

**Western Branch**

223 Hansford Building,  
San Francisco, California,  
WM. R. JOHNSTON, Manager.





No car will last long without perfect lubrication

Perfect lubrication means long life to the bearings and positive assurance all the moving parts are working smoothly and in harmony. Without a PERFECT LUBRICANT no satisfactory results can be obtained.

For over twenty-five years KEYSTONE GREASE has withstood the most exhaustive tests. It is endorsed by the leading manufacturers, mechanical engineers and owners throughout the civilized world, and is justly recognized as the WORLD'S GREATEST LUBRICANT

ONE POUND of KEYSTONE GREASE will outwear 3 to 4 lbs. of any other grease or lubricating compound (barring none).

ONE POUND of KEYSTONE GREASE will outlast 4 to 6 gal. of any lubricating oil (barring none).

KEYSTONE GREASE can always be depended upon to give perfect satisfaction.

Its natural density never changes with variations of temperature. We guarantee that it won't "thin out" or "thicken up." In the Cobalt Mining districts, where it is often 40° below zero, KEYSTONE is universally specified. In the Canal zone, where the BEST is required, the U. S. Government specify KEYSTONE.

KEYSTONE GREASE



### KEYSTONE GREASE

can be used on every bearing of your Automobile or Motor Boat except in the cylinders. Automobile users will find every can containing the genuine KEYSTONE GREASE bears the imprint of our registered Keystone trade-mark and the firm name. KEYSTONE GREASE may be purchased through any Automobile Supply Dealer or Garage, or direct from our branch offices enumerated below. Prices quoted on request.

#### SPECIAL OFFER

To Supply Dealers and Garages for limited time only. Write To-Day.

This Company has no connection with the Oil Trust.

## Keystone Lubricating Co.

Executive Offices and Works, Philadelphia, Pa.

#### BRANCHES

- New England Office, 10 Oliver St., Boston, Mass.
- Southern Office, 610 Chartres St., New Orleans, La.
- Northwestern Office, 203 McPhee Building, Denver.
- San Francisco Office and Warehouse, 268 Market St.
- New York City Office, 96 Warren St.
- Chicago Office, 1210 Tacoma Building

















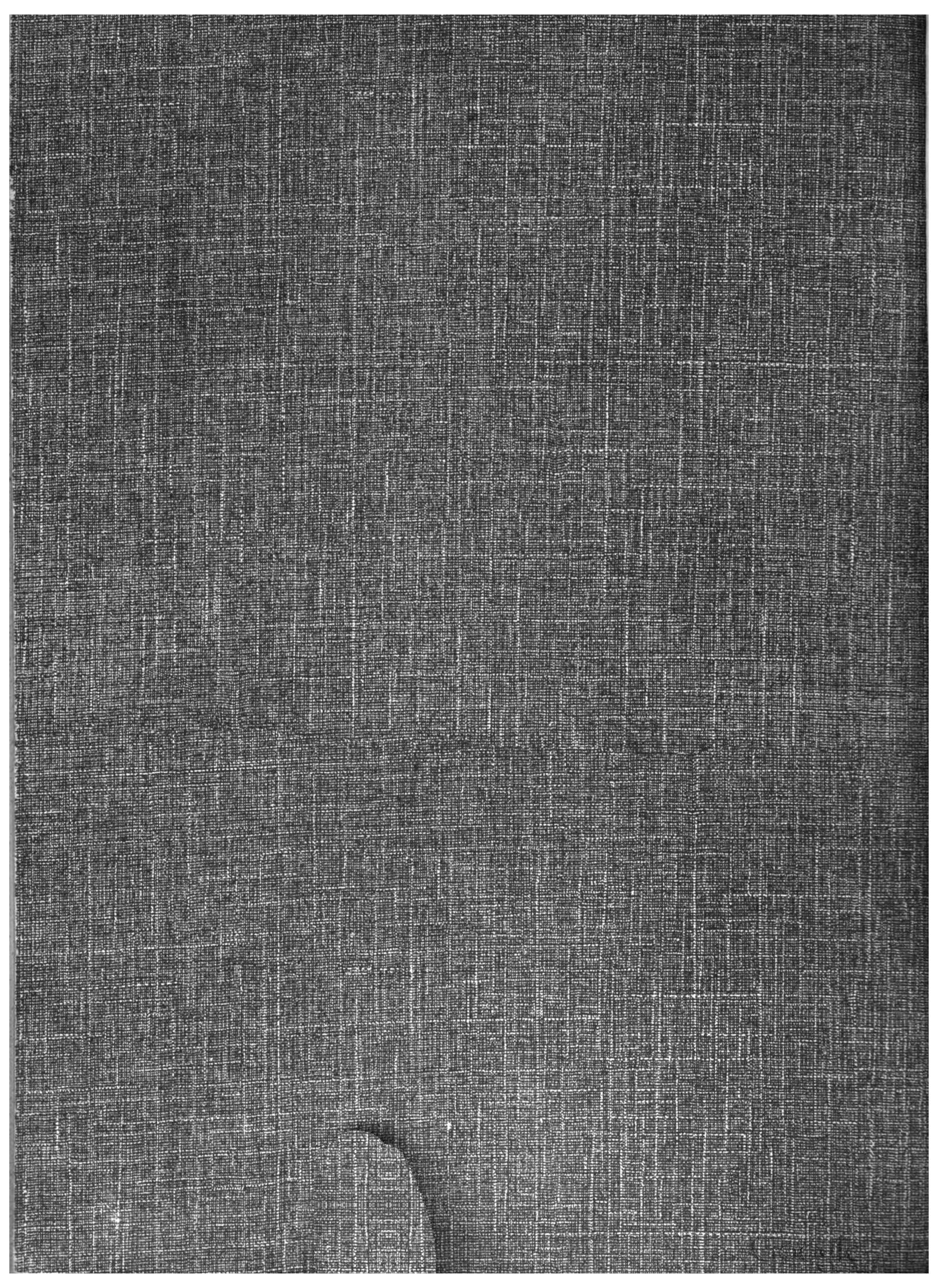







3 9015 02446 6230





